

### **3. INSPECTION/ADJUSTMENT**

---

---

---

**3**

### **INSPECTION/ADJUSTMENT**

---

SERVICE INFORMATION-----	3-1
MAINTENANCE SCHEDUL -----	3- 3
FUEL LINE-----	3- 5
THROTTLE OPERATION-----	3- 5
AIR CLEANER -----	3-7
CRANKCASE BREATHER -----	3- 8
SPARK PLUG-----	3- 8
VALVE CLEARANCE -----	3-10
ENGINE OIL -----	3-13
ENGINE OIL FILTER CARTRIDGE -----	3-15
RADIATOR COOLANT -----	3-16
COOLING SYSTEM-----	3-17
TRANSMISSION OIL -----	3-18
BRAKE FLUED -----	3-19
BRAKE PAD WEAR -----	3-20
BRAKE SYSTEM -----	3-20
BRAKE LOCK OPERATION -----	3-21
HEADLIGHT AIM -----	3-22
SIDE STAND-----	3-23
SUSPENSION-----	3-24
WHEELS/TIRES-----	3-24
STEERING HEAD BEARINGS-----	3-25

### 3. INSPECTION/ADJUSTMENT

#### SERVICE INFORMATION

##### GENERAL

- Place the scooter on a level ground before starting any work.
- Gasoline is extremely flammable and is explosive under certain conditions.
- Work in a well ventilated area. Smoking or allowing flames or sparks in the work area or where the gasoline is stored can cause a fire or explosion.
- If the engine must be running to do some work, make sure the area is well ventilated. Never run the engine in an enclosed area.
- The exhaust contains poisonous carbon monoxide gas that may cause loss of consciousness and may lead to death. Run the engine in an open area or with an exhaust evacuation system in an enclosed area.

##### SPECIFICATIONS

ITEM		SPECIFICATIONS	
Throttle free play		2-6 mm (1/16 – 1/4 in)	
Spark plug		NGK	DR8E
Spark plug gap		0.6~0.7 mm	
Valve clearance	IN	0.16 mm	
	EX	0.22 mm)	
Engine oil capacity	At draining	2.75 liter	
	Total amount	3.0 liter	
Recommended engine oil		KYMCO 4-stroke oil or equivalent motor oil API service classification: SJ Viscosity: 5W50	
Engine idle speed		1250±100 rpm	
Final reduction oil capacity	At draining	0.36 liter	
	Total amount	0.4 liter	
Recommended final reduction oil		SAE 90	
Recommended brake fluid		DOT 4	
Tire size	Front	120/70-R15	
	Rear	160/60-R14	
Tire air pressure	Solo riding	Front	2 kgf/cm <sup>2</sup>
		Rear	2.25 kgf/cm <sup>2</sup>
	Two up riding	Front	2 kgf/cm <sup>2</sup>
		Rear	2.5 kgf/cm <sup>2</sup>
Minimum tire tread depth	Front	1.6 mm (0.06 in)	
	Rear	2.0 mm (0.08 in)	

### **3. INSPECTION/ADJUSTMENT**

---

#### **TORQURE VALUES**

Engine oil drain plug	2.5 kgf•m
Oil strainer screen cap	1.2~1.8 kgf•m
	Apply oil to the threads and seating surface.
Oil filter cartridge	1~2 kgf•m
	Apply oil to the threads and seating surface.
Transmission oil drain bolt	2~3 kgf•m
Transmission oil filler bolt	1.2~1.8 kgf•m

#### **SPECIAL TOOLS**

Oil filter cartridge wrench	A120E00061
-----------------------------	------------

### 3. INSPECTION/ADJUSTMENT

#### MAINTENANCE SCHEDULE

Perform the pre-ride inspection in the owner's manual at each scheduled maintenance period. This interval should be judged by odometer reading or months, whichever comes first.

I: INSPECT AND CLEAN, ADJUST, LUBRICATE OR REPLACE IF NECESSARY

C: CLEAN      R: REPLACE      A: ADJUST      L: LUBRICATE

FREQUENCY	WHICHEVER COMES	ODOMETER READING [NOTE (1)]							
		NOTE	MONTH	6	12	18	24	30	36
AIR CLEANER	NOTE 2			R	R	R	R	R	R
SPARK PLUGS					R		R		R
THROTTLE OPERATION					I		I		I
VALVE CLEARANCE							I		
FUEL LINE					I		I		I
CRANKCASE BREATHER	NOTE 3			C	C	C	C	C	C
ENGINE OIL			R	R	R	R	R	R	R
ENGINE OIL FILTER			R	R	R	R	R	R	R
ENGINE OIL STRAINER SCREEN			C	C	C	C	C	C	C
ENGINE IDLE SPEED			I	I	I	I	I	I	I
RADIATOR COOLANT	NOTE 6				I		I		R
COOLING SYSTEM					I		I		I
SECONDARY AIR SUPPLY SYSTEM					I		I		I
TRANSMISSION OIL	NOTE 5		R						
DRIVE BELT	NOTE 4					I			I
CLUTCH SHOE WEAR				I	I	I	I	I	I
BRAKE FLUID	NOTE 7			I	I	I	R	I	I
BRAKE PAD WEAR				I	I	I	I	I	I
BRAKE SYSTEM			I		I		I		I
BRAKE LIGHT SWITCH					I		I		I
BRAKE LOCK OPERATION			I	I	I	I	I	I	I
SIDE STAND					I		I		I
SUSPENSION					I		I		I
HEADLIGHT AIM					I		I		I
NUTS, BOLTS, FASTENERS			I		I		I		I
WHEELS/TIRES					I		I		I
STEERING BEARINGS			I		I		I		I

### **3. INSPECTION/ADJUSTMENT**

---

NOTE:

- 1 At higher odometer readings, repeat at the frequency interval established here.
- 2 Service more frequently if the scooter is ridden in unusually wet or dusty areas.
- 3 Service more frequently when riding in rain or at full throttle.
- 4 Inspect every 18000 km (12000 mi) after replacement.
- 5 Replace every 1 year, or every 10000km (6000mi), whichever comes first.
- 6 Replace every 2 year, or at indicated odometer interval, whichever comes first.
- 7 Replace every 2 years. Replacement requires mechanical skill.

### 3. INSPECTION/ADJUSTMENT

- \* • Do not smoke or allow flames or sparks in your working area.

#### FUEL FILTER

Visually check the fuel filter. If accumulation of sediment or clogging is found, replace the fuel filter with a new one.



r

#### THROTTLE OPERATION

Check for smooth throttle grip full opening and automatic full closing in all steering positions.

Check the throttle cables and replace them if they are deteriorated, kinked or damaged. Lubricate the throttle cables, if throttle operation is not smooth.

Measure the throttle grip free play.

**Free Play:** 2~6 mm (1/16~1/4 in)

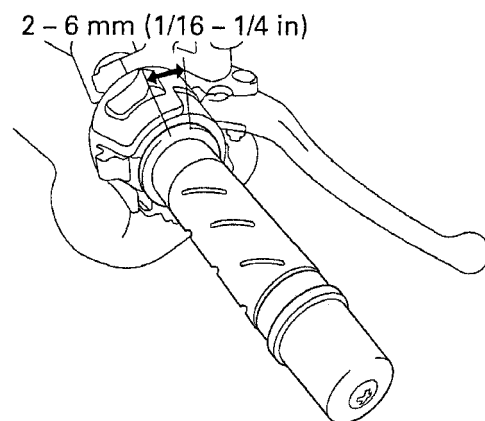

### 3. INSPECTION/ADJUSTMENT

---

Throttle grip free play can be adjusted at either end of the throttle cable.

Minor adjustment is made with the upper adjuster.

Slide the rubber sleeve back to expose the throttle cable adjuster.

Adjust the free play by loosening the lock nut and turning the adjuster.

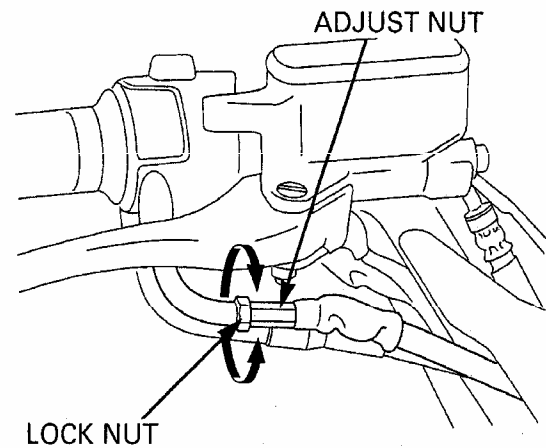

### 3. INSPECTION/ADJUSTMENT

#### AIR CLEANER

The air cleaner should be serviced at regular intervals. Service more frequently when riding in unusually wet or dusty areas.

Install a new air cleaner element. Use the KYMCO genuine air cleaner element or an equivalent air cleaner element specified for your model. Using the wrong, KYMCO air cleaner element or a non-KYMCO air cleaner which is not of equivalent quality may cause premature engine wear or performance problems.

#### Air cleaner element removal/installation



Remove the screws and air cleaner housing cover

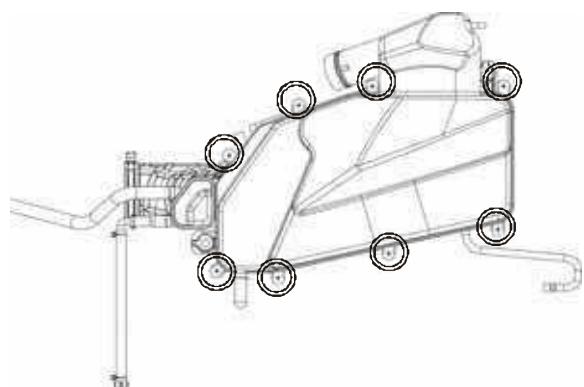



### 3. INSPECTION/ADJUSTMENT

Remove the air cleaner element.  
Check the cleaner element.

Install the removed parts in the reverse order of removal.

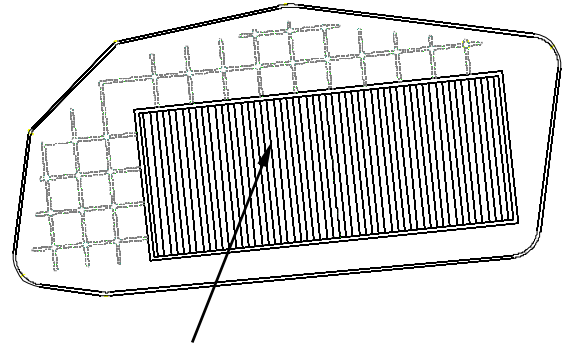

Air Cleaner Element

#### **Air cleaner element removal/installation**

Remove the luggage box.

Remove the six screws and air cleaner cover.

#### **CRANKCASE BREATHER**

Remove the crankcase breather tube plug from the tube and drain deposits into a suitable container.

Reinstall the crankcase breather tube plug.

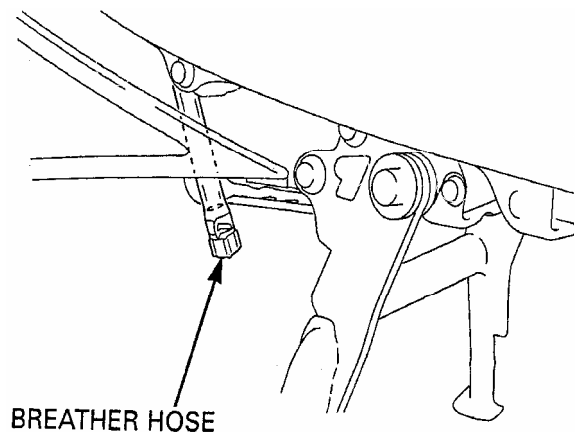

BREATHER HOSE

Service more frequently when riding in rain, at full throttle, or after the scooter is washed or overturned. Service if the deposit level can be seen in the transparent section of the drain tube.

#### **SPARK PLUG**

##### **REMOVAL**

Remove the spark plug maintenance lid



Spark plug lid

### 3. INSPECTION/ADJUSTMENT

Remove the spark plug using an equipped spark plug wrench or an equivalent tool.

Inspect or replace as described in the maintenance schedule.



Spark Plug

#### INSPECTION

Remove the carbon deposits from the spark plug with a small wire brush or a spark plug cleaning machine.

The spark plug should be replaced periodically. Whenever removing the carbon deposits, be sure to observe the operational color of the spark plug's porcelain tip. This color tells you whether or not the standard spark plug is suitable for your type of usage. A normal operating spark plug should be light brown or tan color. If the spark plug is very white or glazed appearing, then it has been operating much too hot. This spark plug should be replaced with the colder plug.

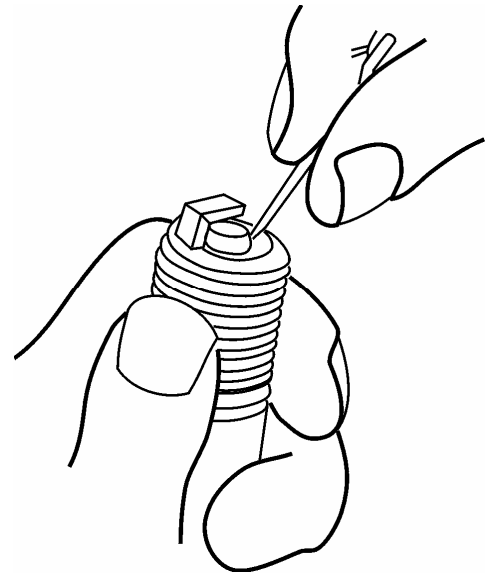

#### Recommended spark plug: DR8E

Measure the spark plug gap between the center and side electrodes with the feeler gauge.

If necessary, adjust the gap by bending the side electrode carefully.

**Spark plug gap:**  
**0.6–0.7 mm (0.024–0.028 in)**

Install the spark plug in the cylinder head and hand tighten, then torque to the specification.

**Torque: 1.0~1.4 kg•m**

Install the spark plug cap.

Install the removed parts in the reverse order of removal.

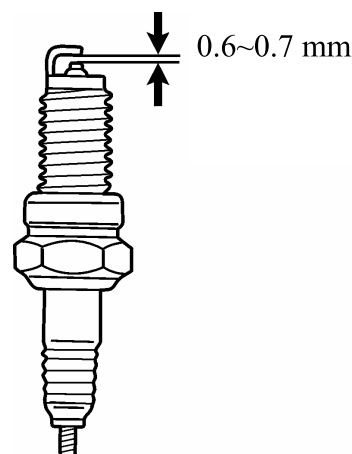

### 3. INSPECTION/ADJUSTMENT

#### VALVE CLEARANCE

\* Inspect and adjust the valve clearance while the engine is cold (Below 35°C/95°F).

#### Inspection and adjust

Remove the cylinder head cover.

Remove the timing hole cap and O-ring.  
Remove the crankshaft hole cap and O-ring.

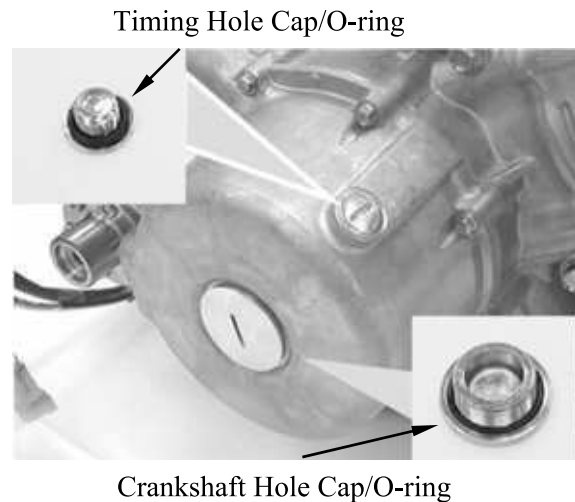

Turn the crankshaft clockwise and align the "T" mark on the flywheel with the index mark on the right crankcase cover.

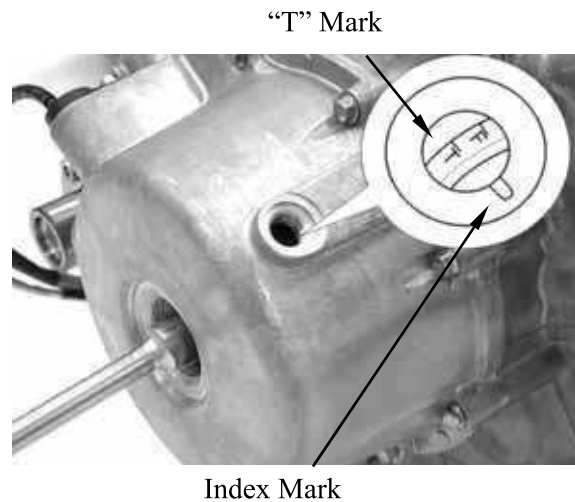

The punch marks "in" and "ex" on the camshaft should be aligned with the boundary of cylinder head as shown.

If the punch marks on the camshaft are facing downward, turn the crankshaft clockwise one full turn (360°) and the punch marks are facing upward.

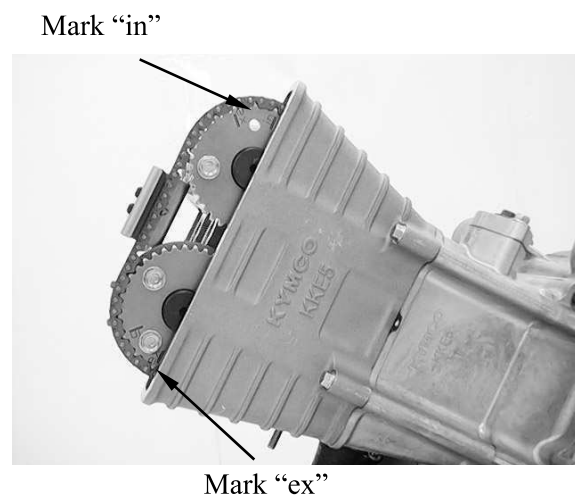

### 3. INSPECTION/ADJUSTMENT

Insert the feeler gauge between the valve lifter and the cam lobe.  
Check the valve clearance for the valves using a feeler gauge.

#### Valve Clearance

**IN:0.16 mm(0.006 in)**

**EX:0.22 mm(0.009in)**

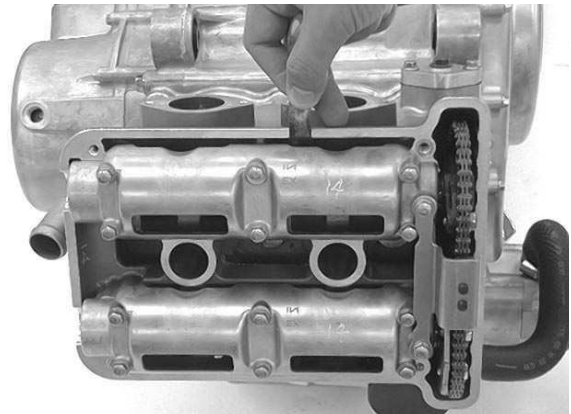

Remove the camshaft.

Remove the valve lifters and shims.

The shims may stick to the inside of the valve lifter. Don't allow the shims to fall into the crankcase.

Mark all of shims and valve lifters to ensure correct reassembly in original locations.

The valve lifter can be easily removed with a valve lapping tool or magnet.

The shims can be easily removed with tweezers or magnet.

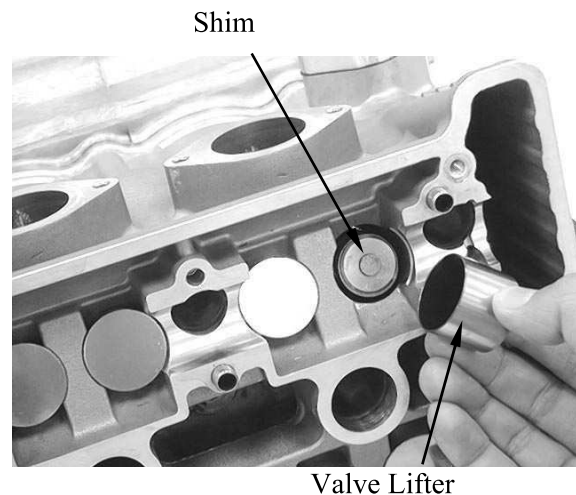

Clean the valve shim contact area in the valve lifter with compressed air.

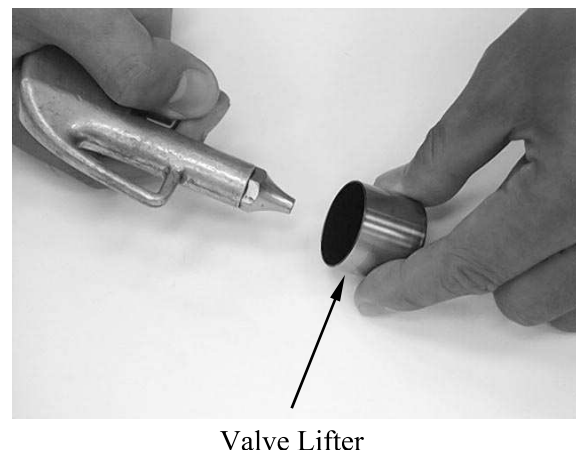

### 3. INSPECTION/ADJUSTMENT

Measure the shim thickness and record it.  
Calculate the new shims thickness using the equation below.

$$A+C=B+D$$

- A: New shim thickness
- B: Record valve clearance
- C: Specified valve clearance
- D: Old shim thickness

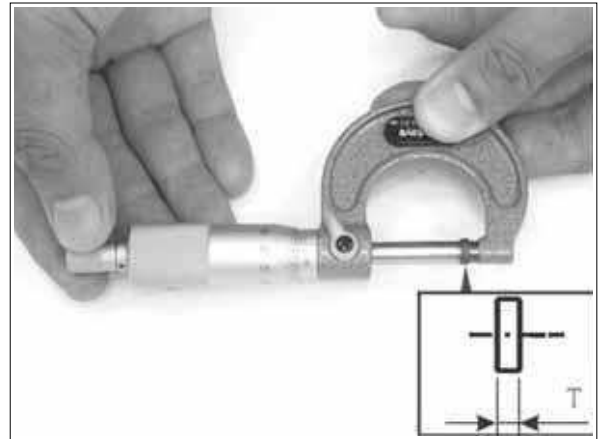

Grade number	“T” Thickness	Mark
01	1.80	180
02	1.85	185
03	1.90	190
04	1.95	195
05	2.00	200
06	2.05	205
07	2.10	210
08	2.15	215
09	2.20	220
10	2.25	225
11	2.30	230
12	2.35	235
13	2.40	240
14	2.45	245
15	2.50	250
16	2.55	255
17	2.60	260
18	2.65	265
19	2.70	270
20	2.75	275
21	2.80	280
22	2.85	285
23	2.90	290
24	2.95	295
25	3.00	300

Make sure the correct shim is selected by measuring it with a micrometer.

Reface the valve seat if carbon deposits result in a clearance of over 2.8mm

Install the removed parts in the reverse order of removal.

### 3. INSPECTION/ADJUSTMENT

#### ENGINE OIL

##### OIL LEVEL INSPECTION

Start the engine and let it idle for 2—3 minutes.

Turn off the engine and support the scooter level surface.

Check the engine oil level. The level must be maintained between the upper H (1) and lower level L (2) marks on the oil inspection screen (3).

If the oil level is below or near the lower level line, add the recommended engine oil until the oil level is to the upper level.

Change the engine oil with the engine at normal operating temperature and the scooter on its center stand to assure complete and rapid draining.

Remove the oil filler cap from the right crankcase cover.

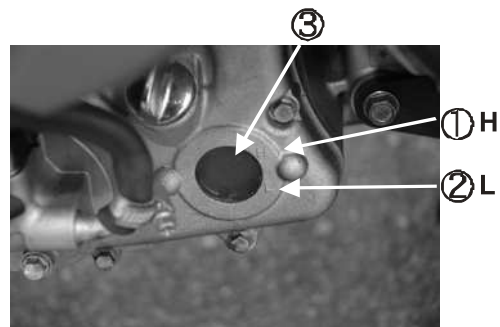

**Engine oil capacity: 3.0 L**  
**Engine oil exchanging capacity: 2.6 L**

##### Recommended engine oil:

KYMCO 4-stroke oil or equivalent motor oil API service classification: SJ

Viscosity: SAE 5W50

\* Other viscosities shown in the chart may be used when the average temperature in your riding area is within the indicated range.

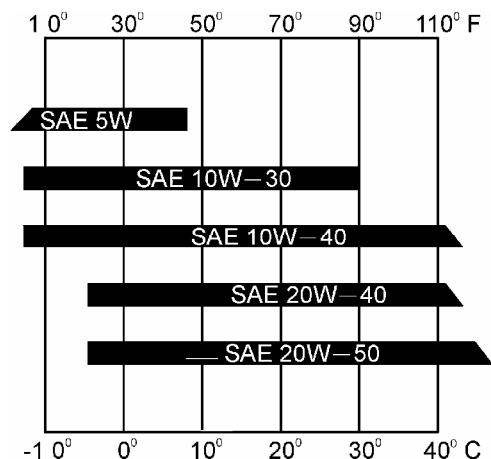

##### ENGINE OIL & STARINER SCREEN

When running in very dusty conditions, oil changes should be performed more frequently than specified in the maintenance schedule.

Please dispose of used engine oil in a manner that is compatible with the environment. We suggest you take it in a sealed container to your local recycling center or service station for reclamation. Do not throw it in the trash or pour it on the ground or down a drain.

Used engine oil may cause skin cancer if repeatedly left in contact with the skin for prolonged periods. Although this is unlikely unless you handle used oil on a daily basis, it is still advisable to thoroughly wash your hands with soap and water as soon as possible after handling used oil.

### 3. INSPECTION/ADJUSTMENT

Place a drain pan under the crankcase and remove the oil strainer cap.

The setting spring and oil strainer screen will come out when the oil strainer cap is removed.

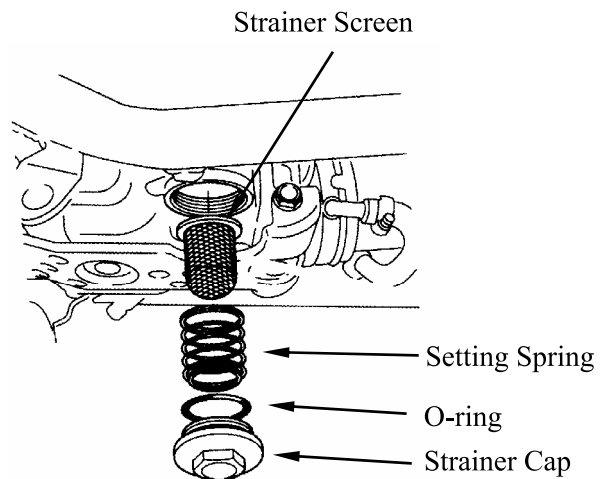
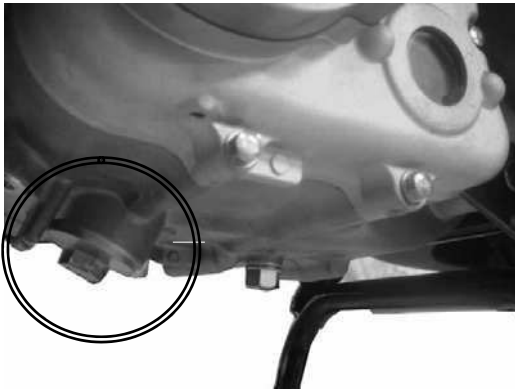

Clean the oil strainer screen.

After draining the oil completely, install the strainer screen and setting spring into the engine.

Oil Strainer Screen

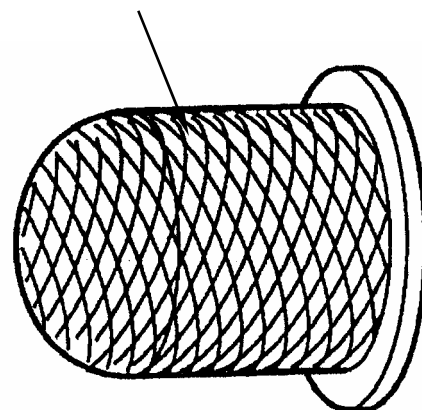

Strainer Screen

Apply clean engine oil to the strainer cap threads, flange surface and a new O-ring. Install and tighten the strainer cap with a new O-ring.

**Torque: 1~2 kgf•m**

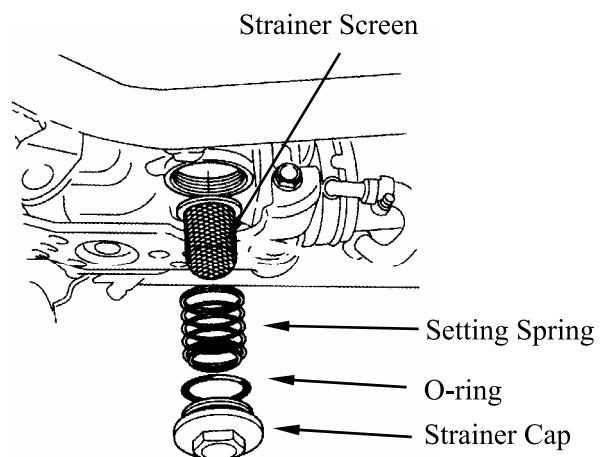

### 3. INSPECTION/ADJUSTMENT

Fill the crankcase with the recommended engine oil.

**Engine oil capacity: 3.0 L**  
**Engine oil exchanging capacity: 2.6 L**

Install the oil filler cap.  
Check the engine oil level.  
Make sure there are no oil leaks



#### **ENGINE OIL FILTER CARTRIDGE REPLACEMENT**

Drain the engine oil.

Remove and discard the oil filter cartridge using the special tool.

**Tool:**  
**Oil filter wrench: A120E00061**

Apply clean engine oil to the new oil filter cartridge threads, flange surface and a new O-ring.

Install the new oil filter cartridge and tighten it to the specified torque.

O-ring

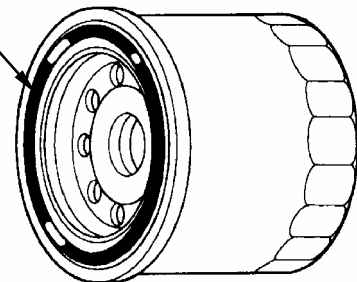

**Torque: 2.4~3 kgf•m**

Refill the engine oil



### 3. INSPECTION/ADJUSTMENT

#### RADIATOR COOLANT

Place the scooter on its center stand.

The reserve tank is under left footboard.

Check the coolant level through the inspection window (1) at the left side skirt while the engine is at the normal operating temperature with the scooter in an upright position. If the coolant level is below the LOWER level mark (3),

remove the left floor mat, remove the lid screw and reserve tank lid and the

Reserve tank cap (4) and add coolant mixture until it reaches the upper level mark (2).

Remove the left floor mat and remove screw and reserve tank lid.

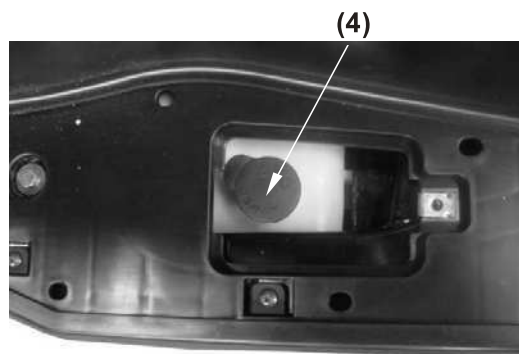
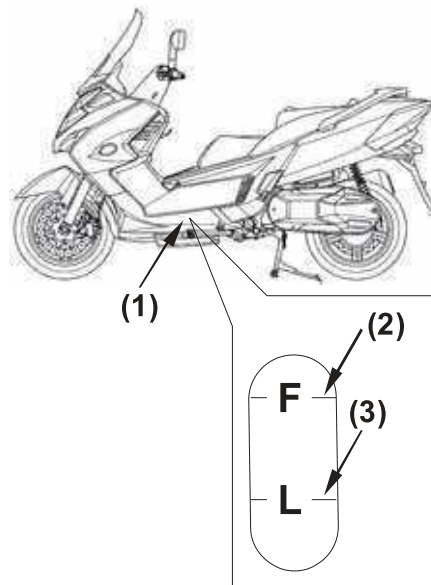

Remove reserve tank cap.

Check to see if there are any coolant leaks when the coolant level decrease very rapidly.

If reserve tank becomes completely empty, there is a possibility of air getting into the cooling system.

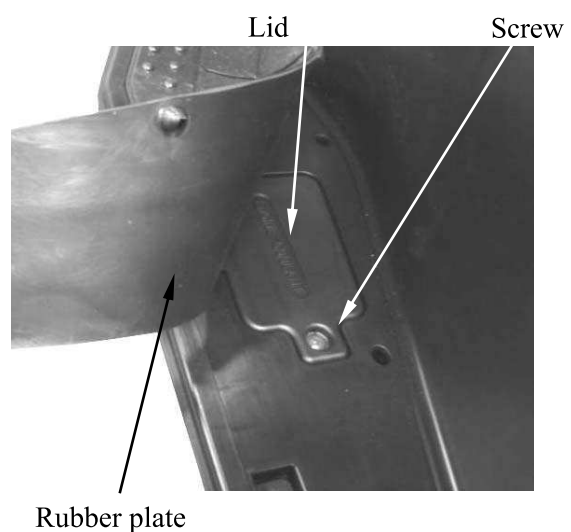

Be sure to remove all air from the cooling system.

Reinstall the filler cap.

### 3. INSPECTION/ADJUSTMENT

#### COOLING SYSTEM

Check for any coolant leakage from the water pump, radiator hoses and hose joints.  
Check the radiator hoses for cracks or deterioration and replace if necessary.  
Check that all hose clamps are tight.

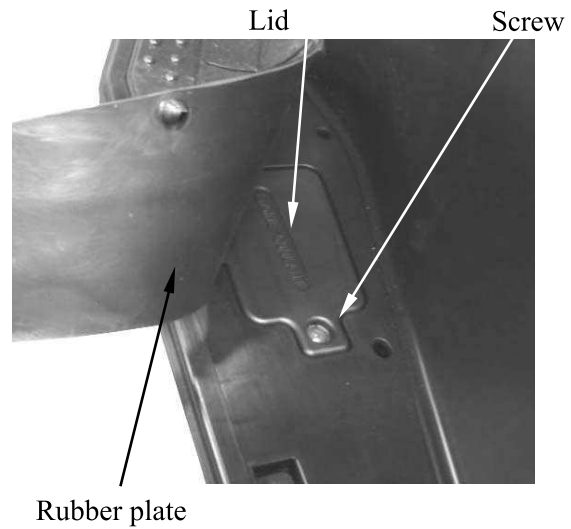

Check the radiator air passages for clogs or damage.  
Straighten any bent fins, and remove insects, mud or other obstructions with compressed air or low water pressure.  
Replace the radiator if the air flow is restricted over more than 20% of the radiating surface.

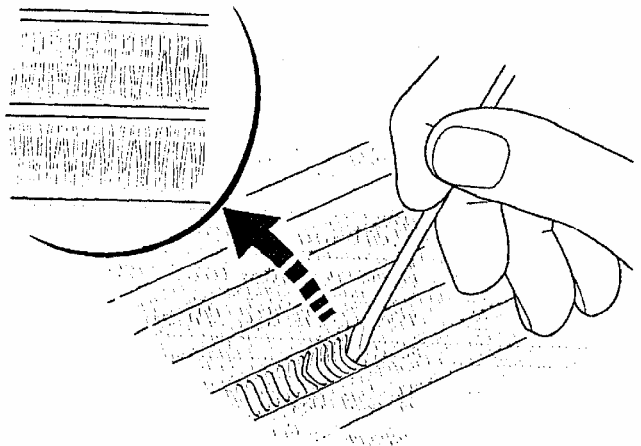

### 3. INSPECTION/ADJUSTMENT

#### TRANSMISSION OIL OIL CHANGE

Place the scooter in its center stand.

Remove the transmission oil drain bolt (1) and the transmission oil filler bolt (2), slowly turn the rear wheel and drain the oil.

After draining the oil completely, install the oil drain bolt with a new sealing washer and tighten it.

**Torque: 2~3 kgf•m**



oil drain bolt (1)

Fill the transmission case with recommended oil.

Recommended transmission oil: SAE 90

**Oil capacity: 0.40 L**

**Oil exchanging capacity: 0.32L**

Install the transmission oil filler bolt with a new sealing washer and tighten it.

oil filler bolt (2)

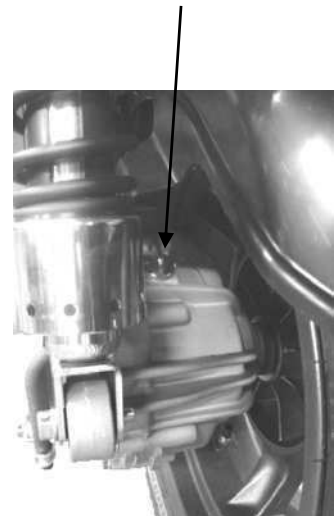

### 3. INSPECTION/ADJUSTMENT

#### BRAKE FLUID

- \*
  - ♦ Do not mix different type of fluid, as they are not compatible with each other.
  - ♦ Do not allow foreign material to enter the system when filling the reservoir.
  - ♦ Avoid spilling fluid on painted, plastic or rubber parts. Place a rag over these parts whenever the system is serviced.



#### Brake fluid level inspection:

With the scooter in an upright position, check the front and rear fluid level. The level should be above the lower level mark. If the level is at or below the lower level mark "L", check the brake pads for wear.

Worn break pads should be replaced immediately. If the pads are not worn, have your brake system inspected for leaks. Do not ride your scooter unless the brakes are in perfect working order.

Brake fluid type: DOT 4 (from a sealed container)

Note: Other checks- Make sure there are no fluid leaks. Check for deterioration or cracks in the hoses and fittings.

### 3. INSPECTION/ADJUSTMENT

#### BRAKE PAD WEAR

Brake pad wear depends upon the severity of usage, the type of riding, and road conditions. (Generally, the pads will wear faster on wet and dirty roads.) Inspect the pads at each regular maintenance interval.

##### Front/Rear brake

Check the cutout in each brake pad, the cutout should be visible, indicating that brake pad is not worn down to the brake rotor. If either pad is worn to the cutout, replace both pads as a set.

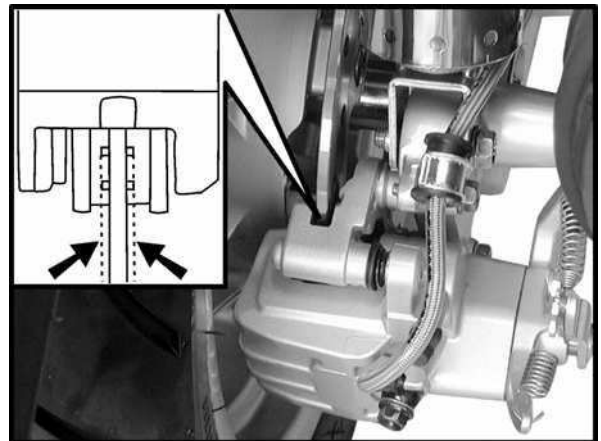

#### BRAKE SYSTEM

##### INSPECTION

Check the free play of front/rear brake lever.

**Standard of free play:** 10~20 mm

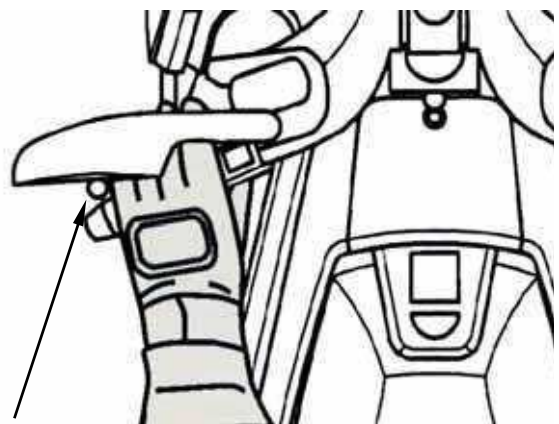

Rear Brake Lever

### 3. INSPECTION/ADJUSTMENT

Operate the rear brake lever.  
 Make sure the front wheel does not turn while the brake lever is operated.

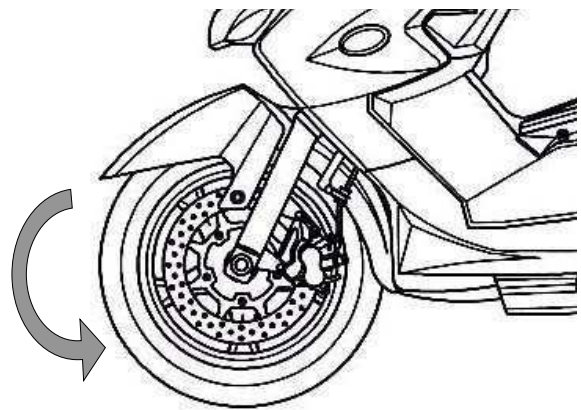

Firmly apply the brake lever and check that no air has entered the system.  
 If the lever feels soft or spongy when operated, bleed the air from the system.

Inspect the brake hose and fittings for deterioration, cracks and signs of leakage.  
 Tighten any loose fittings.  
 Replace hoses and fittings as required.

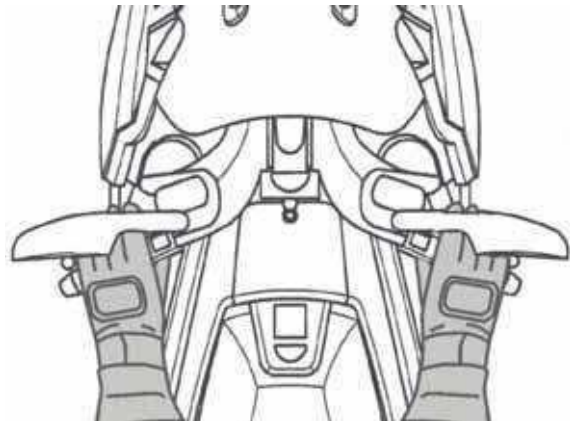

#### **BRAKE LOCK OPERATION**

##### **INSPECTION**

Stop the engine and put the scooter on its center stand on level ground.

Pull up the parking brake lever slowly and check the parking brake lever stroke.

**Parking brake lever stroke: 3 — 6 cm**

If out of specification, adjust the parking brake lever.



### 3. INSPECTION/ADJUSTMENT

#### ADJUSTMENT

Place the scooter on its center stand.  
Release the parking brake lever lock.  
Pull up the parking brake lever.

Loosen the lock nut.  
Turn the adjust bolt until you feel resistance when turn the rear wheel by your hand.  
Hold the adjust bolt and tighten the lock nut securely.

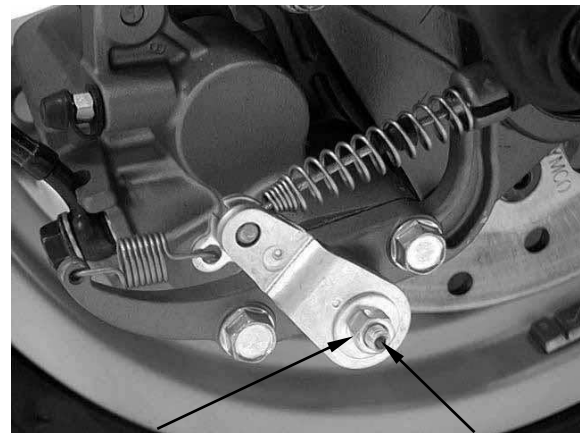

Nut

Bolt

Release the parking brake lever.  
Make sure the rear wheel turns smoothly.

Pull the parking brake lever slowly and check the lever stroke.

**Standard: 3 – 6 notches**

#### HEADLIGHT AIM

Place the scooter on a level surface.

Adjust the headlight beam vertically by turning the vertical beam adjuster.  
A clockwise rotation moves the beam up and counterclockwise rotation moves the beam down.

Adjust the headlight beam horizontally by turning the horizontal beam adjuster.  
A clockwise rotation moves the beam toward the right side of the rider.

Horizontally Adjusting Screw



Vertically Adjusting Screw

\* Adjust the headlight beam as specified by local laws and regulations.

## 3. INSPECTION/ADJUSTMENT

### SIDE STAND

Support the scooter on a level surface.

Check the side stand spring for fatigue or damage.

Check the side stand assembly for smooth movement and lubricate the side stand pivot if necessary.

Check the side stand ignition cut-off system:

- ✓ Start the engine.
- ✓ Fully lower the side stand while running the engine.
- ✓ The engine should stop as the side stand is lowered.

If there is a problem with the system, check the side stand switch.

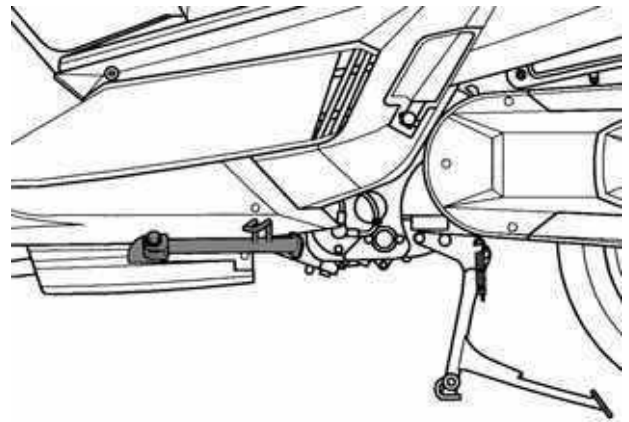

### SUSPENSION

#### FRONT SUSPENSION INSPECTION

Check the action of the forks by operating the front brakes and compressing the front suspension several times.

Check the entire assembly for signs of leaks, damage or loose fasteners.

Replace damaged components which cannot be repaired.

Tighten all nuts and bolts.

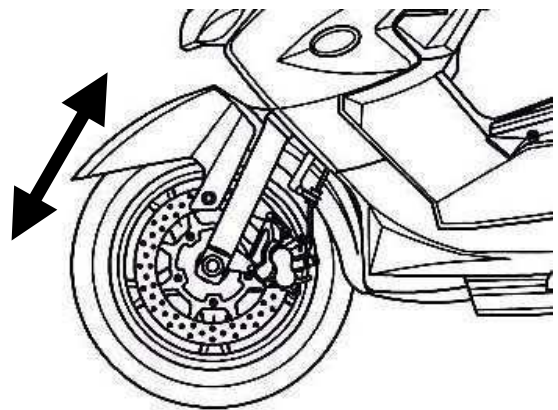



### **3. INSPECTION/ADJUSTMENT**

---

#### **REAR SUSPENSION INSPECTION**

Check the action of the shock absorber by compressing it several times.

Check the entire shock absorber assembly for signs of leaks, damage or loose fasteners.

Replace damaged components which cannot be repaired.

Tighten all nuts and bolts.

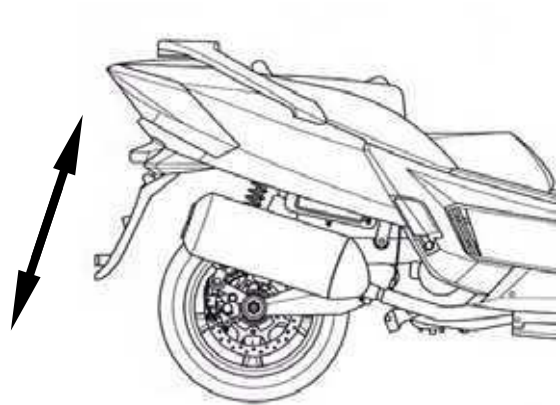

#### **NUTS, BOLTS, FASTENERS**

Check that all chassis nuts and bolts are tightened to their correct torque values (page 1-9).

Check that all safety clips, hose clamps and cable stays are in place and properly secured.

#### **WHEELS/TIRES**

Tire pressure should be checked when the tires are cold.

### 3. INSPECTION/ADJUSTMENT

#### Recommended tire size:

Tire size: front .....120/70-R15  
Tire size: rear.....160/60-R14

Check the tires for cuts, embedded nails, or other damage.  
Check the front and rear wheels for trueness.

Measure the tread depth at the center of the tires.  
Replace the tires when the tread depth reaches the following limits.

**Minimum tread depth:**  
**Front: 1.6 mm**  
**Rear: 2.2 mm**

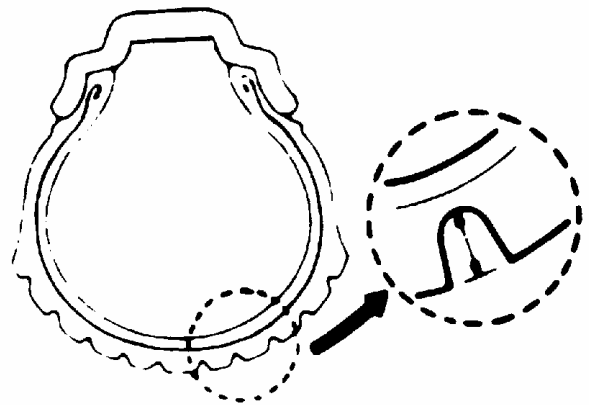

#### STEERING HEAD BEARINGS

Check that the control cables do not interfere with handlebar rotation.

Support the scooter securely and raise the front wheel off the ground.  
Check that the handlebar moves freely from side to side.  
If the handlebar moves unevenly, binds, or has vertical movement, inspect the steering head bearings.

