

3. INSPECTION/ADJUSTMENT

INSPECTION/ADJUSTMENT

SERVICE INFORMATION-----	3- 1
MAINTENANCE SCHEDULE-----	3- 2
FUEL LINE/THROTTLE OPERATION/AIR CLEANER -----	3- 3
AIR FILTER FOR DRIVE BELT -----	3- 4
SPARK PLUG-----	3- 5
VALVE CLEARANCE/CARBURETOR IDLE SPEED-----	3- 6
IGNITION TIMING/CYLINDER COMPRESSION -----	3- 7
ENGINE OIL/FINAL REDUCTION GEAR OIL-----	3- 8
DRIVE BELT/BRAKE SHOE/BRAKE SYSTEM -----	3- 9
HEADLIGHT AIM -----	3-11
STEERING SYSTEM INSPECTION-----	3-12
TOE-IN ADJUSTMENT -----	3-13
WHEELS/TIRES -----	3-14
DRIVE CHAIN SLACK ADJUSTMENT-----	3-15
CABLE INSPECTION AND LUBRICATION-----	3-17
FRONT SUSPENSION LUBRICATION -----	3-17

3. INSPECTION/ADJUSTMENT

MAINTENANCE SCHEDULE

This chapter includes all information necessary to perform recommended inspections and adjustments. These preventive maintenance procedures, if followed, will ensure more reliable vehicle operation and a longer service life. The need for costly overhaul work will be greatly reduced. This information applies to vehicles already in service as well as new vehicles that are being prepared for sale. All service technicians should be familiar with this entire chapter.

ITEM	WHICHEVER COMES FIRST ROUTINE	INITIAL		EVERY	
		mi	100	600	1200
		Km	150	1000	2000
		MONTH	1	6	12
Engine oil	•Replace (Warm engine before draining).		○	○	○
Oil strainer	•Clean. •Replace if necessary.		○	○	○
Transmission oil	•Check oil level/oil leakage •Replace every 12 months.		○		○
V-belt	•Check operation. •Replace if damage or excessive wear.		○		○
Air filter element (for engine and *V-belt compartment)	•Clean. •Replace if necessary.	Every 20~40 hours (150~300km, 100~200mi) (More often in wet or dusty areas.)			
Carburetor	•Check idle speed/starter operation. •Adjust if necessary.		○	○	○
Cylinder head cover breather system	•Check breather hose for cracks or damage. •Replace if necessary.			○	○
Spark plug	•Check condition. •Adjust gap and clean. •Replace if necessary.		○	○	○
Fuel line	•Check fuel hose for cracks or damage. •Replace if necessary.			○	○
Valves	•Check valve clearance. •Adjust if necessary.		○	○	○
Brake	•Check operation and brake fluid. •Replace brake pad if necessary.		○	○	○
Coolant	•Check coolant leakage. •Replace if necessary. •Replace coolant every 24 months.		○	○	○
Battery	•Check specific gravity. •Check breather hose for proper operation. •Correct if necessary.		○	○	○
Exhaust system	•Check leakage. •Retighten if necessary. •Replace gasket if necessary.			○	○
Drive chain	•Check and adjust slack/alignment/clean/lube.		○	○	○
Wheels	•Check balance/damage/runout. •Replace if necessary.		○	○	○
Wheel bearings	•Check bearing assembly for looseness/damage. •Replace if damaged.		○	○	○
Steering system	•Check operation. •Replace if damaged. •Check toe-in. •Adjust if necessary.		○	○	○
Knuckle shafts/ Steering shaft	•Lubricate every 6 months.			○	○
Fittings and Fasteners	•Check all chassis fittings and fasteners. •Correct if necessary.		○	○	○
Spark arrester (OFF ROAD)	•Clean			○	○

•In the interest of safety, we recommend these items should be serviced only by an authorized KYMCO motorcycle dealer.

3. INSPECTION/ADJUSTMENT

FUEL LINE

Remove the met-in box.
Check the fuel tubes and replace any parts, which show signs of deterioration, damage or leakage.

* Do not smoke or allow flames or sparks in your working area.

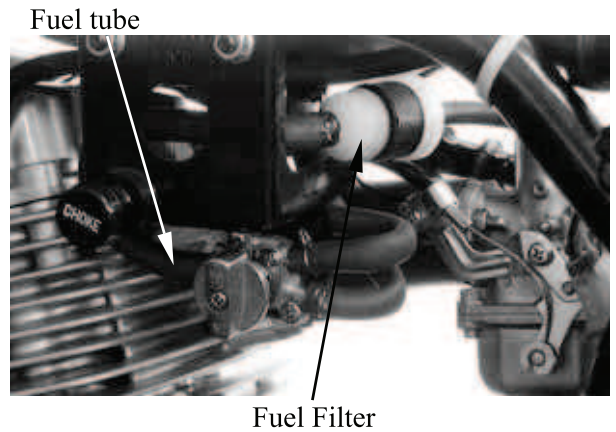

THROTTLE OPERATION

Check the throttle to swing for smooth movement.
Measure the throttle to swing free play.
Free Play: 1~4 mm (0.04~0.16 in)



Minor adjustment is made with the adjusting nut at the throttle to swing above. Slide the rubber cover out and adjust by loosening the lock nut and turning the adjusting nut.

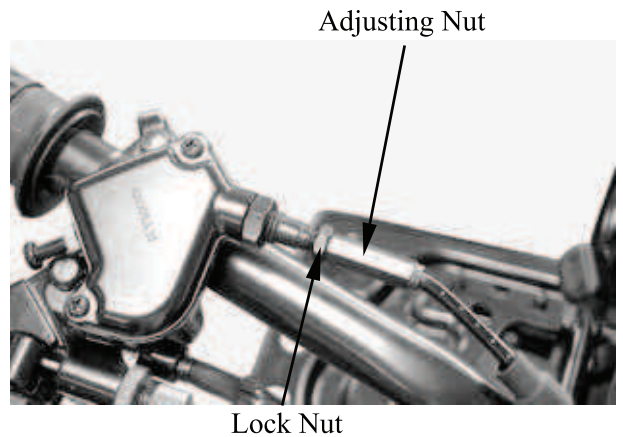

AIR CLEANER

AIR CLEANER REPLACEMENT

Remove the rear side covers.
Remove four screws on the air cleaner case cover and the cover.
Check the element and replace it if it is excessively dirty or damaged.

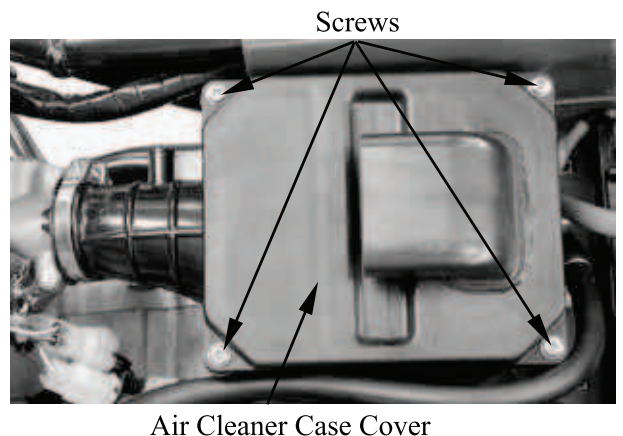

3. INSPECTION/ADJUSTMENT

CLEAN AIR FILTER ELEMENT

Wash the element gently, but thoroughly in solvent.

- * Use parts cleaning solvent only. Never use gasoline or low flash point solvents which may lead to a fire or explosion.

Squeeze the excess solvent out of the element and let dry.

- * Do not twist or wring out the foam element. This could damage the foam material.

Apply the engine oil.

Squeeze out the excess oil.

- * The element should be wet but not dripping.

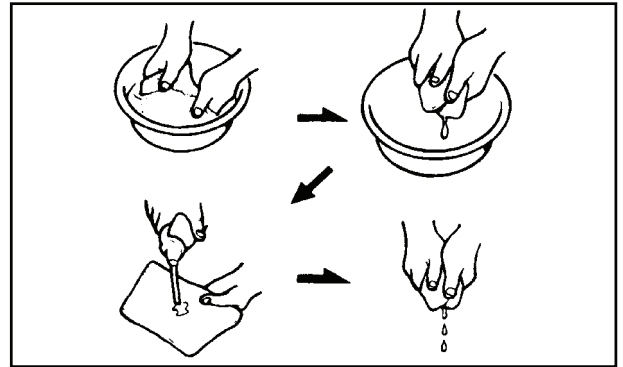

CHANGE INTERVAL

More frequent replacement is required when riding in unusually dusty or rainy areas.

Air Cleaner Element



AIR FILTER FOR DRIVE BELT

Remove the front cover.

Remove the screw, air filter case and air filter element.

Inspect the air filter element.

Replace if damage.

Front cover

Air Filter Case

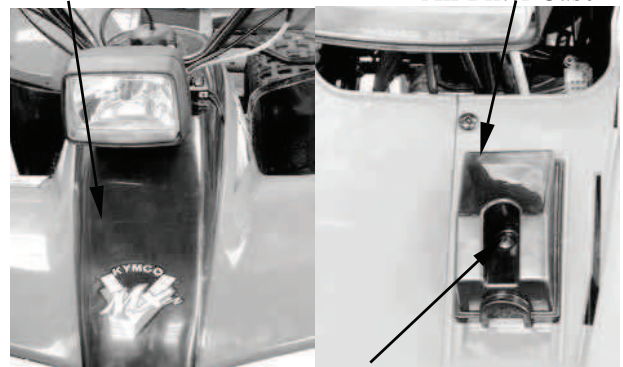

Screw

3. INSPECTION/ADJUSTMENT

Clean air filter element steps:

Tap the element lightly to remove most of the dust and dirt.

Blow out the remaining dirt with compressed air.

Install the air filter element and air filter case.

Install the front cover.

SPARK PLUG

Remove the spark plug.

Check the spark plug for wear and fouling deposits.

Clean any fouling deposits with a spark plug cleaner or a wire brush.

Specified Spark Plug: NGK: DR-8EA

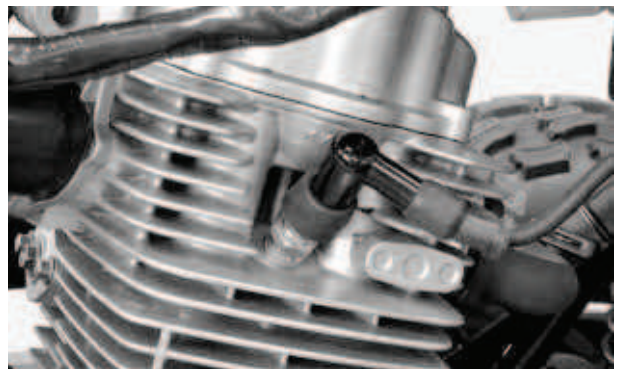

Measure the spark plug gap.

Spark Plug Gap:

0.6~0.7 mm (0.0024~0.0028 in)

* When installing, first screw in the spark plug by hand and then tighten it with a spark plug wrench.

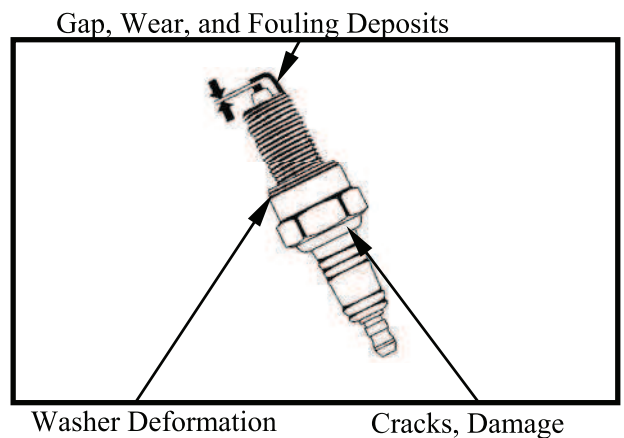

3. INSPECTION/ADJUSTMENT

VALVE CLEARANCE

- * Inspect and adjust valve clearance while the engine is cold (below 35°C).

Remove the cylinder head cover.

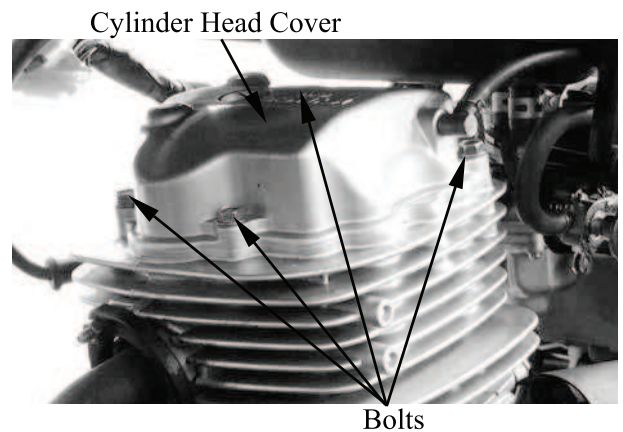

Turn the flywheel counterclockwise so that the "T" mark on the flywheel aligns with the index mark on the crankcase to bring the round hole on the camshaft gear facing up to the top dead center on the compression stroke.

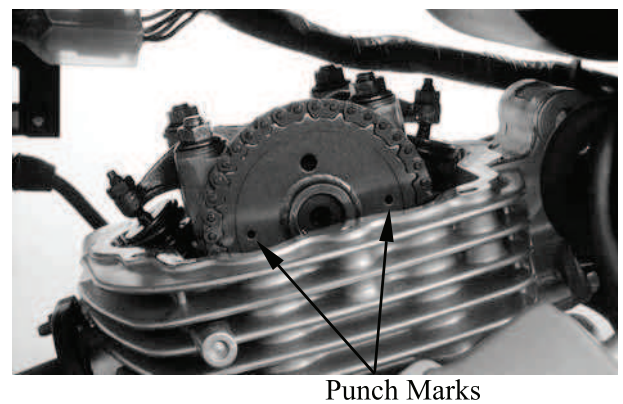

Inspect and adjust the valve clearance.

Valve Clearance: IN: 0.06 mm (0.0024 in)
EX: 0.06 mm (0.0024 in)

Loosen the lock nut and adjust by turning the adjusting nut

Special tool:

Tappet adjuster E012

- * Check the valve clearance again after the lock nut is tightened.

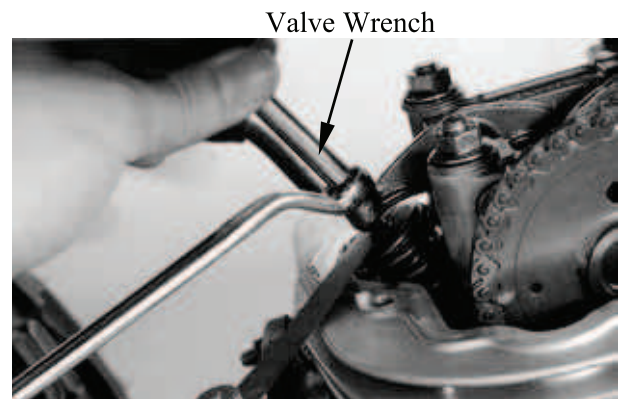

CARBURETOR IDLE SPEED

- * The engine must be warm for accurate idle speed inspection and adjustment.

Warm up the engine before this operation. Start the engine and connect a tachometer. Turn the throttle stop screw to obtain the specified idle speed.

Idle Speed: 1700±100rpm

When the engine misses or run erratic, adjust the air screw.

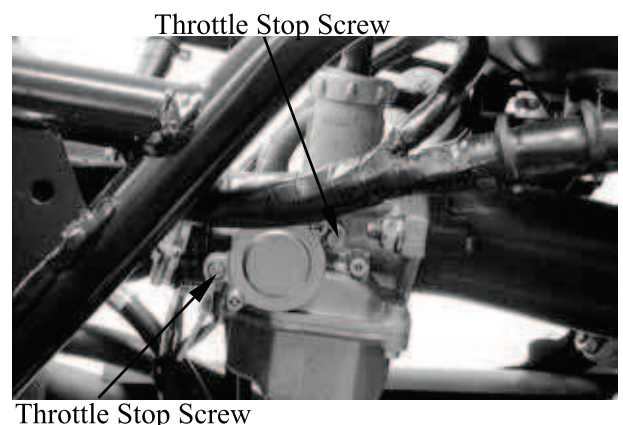

Throttle Stop Screw

3. INSPECTION/ADJUSTMENT

IGNITION TIMING

* The CDI unit is not adjustable. If the ignition timing is incorrect, check the ignition system.

Remove the timing hole cap.

Timing Hole Cap

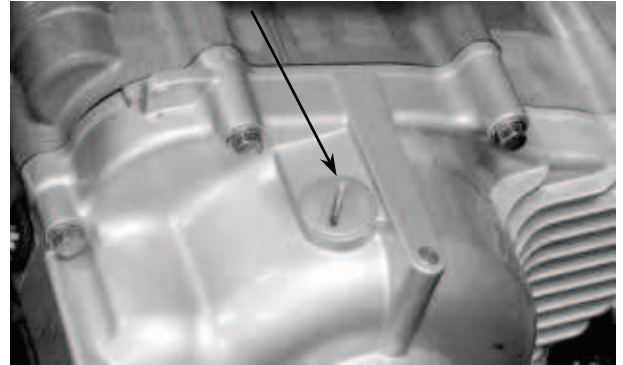

Check the ignition timing with a timing light.

When the engine is running at idle speed, the ignition timing is correct if the "F" mark on the flywheel aligns with the index mark on the crankcase.

Timing Light



CYLINDER COMPRESSION

Warm up the engine before compression test.

Remove the spark plug.

Insert a compression gauge.

Open the throttle valve fully and push the starter button to test the compression.

Compression:

1600 kPa (16kg/cm², 227.2 psi)

If the compression is low, check for the following:

- Leaky valves
- Valve clearance too small
- Leaking cylinder head gasket
- Worn piston rings
- Worn piston/cylinder

If the compression is high, it indicates that carbon deposits have accumulated on the combustion chamber and the piston head.

Compression Gauge

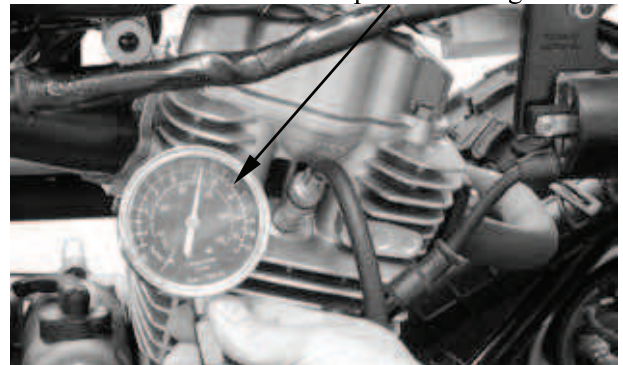

3. INSPECTION/ADJUSTMENT

ENGINE OIL

OIL LEVEL

- * Place the motorcycle upright on level ground for engine oil level check.
- Run the engine for 2~3 minutes and check the oil level after the engine is stopped for 2~3 minutes.

Remove the oil dipstick and check the oil level with the oil dipstick.
If the level is near the lower level, fill to the upper level with the specified engine oil.

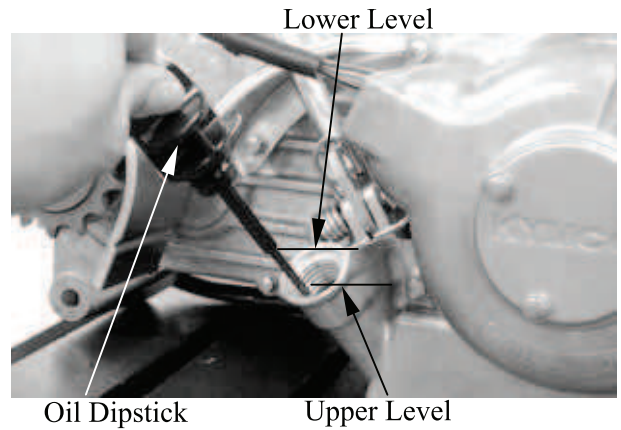

OIL CHANGE

- * The engine oil will drain more easily while the engine is warm.

Remove the oil drain plug bolt located on the bottom of the engine to drain the engine oil thoroughly.
After the oil has been completely drained, install the oil drain plug bolt.

Torque: 2.5 kgf-m (25 N-m, 18 lbf-ft)

Recommended Oil: SAE30#

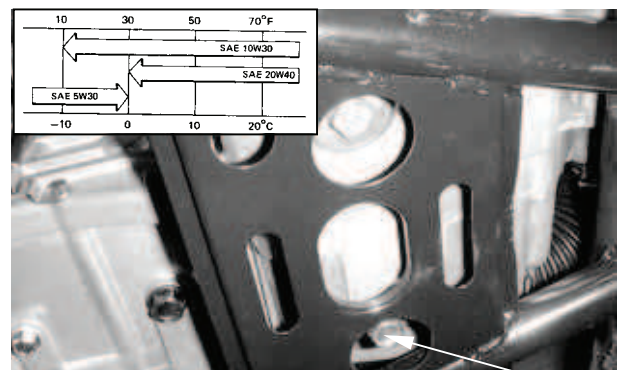

oil drain plug bolt

FINAL REDUCTION GEAR OIL

- * Place the motorcycle on level ground for oil level check.

Recommended Oil: GEAR OIL SAE90#

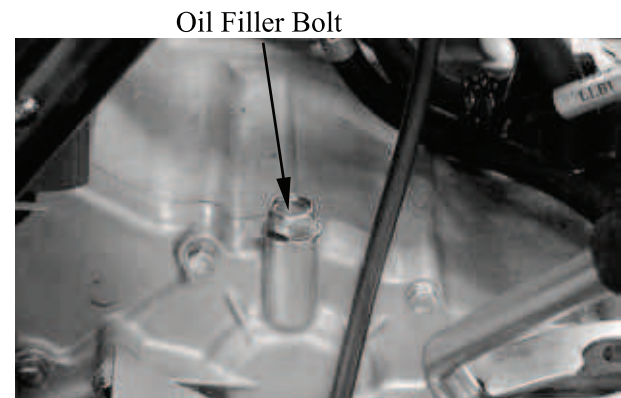

3. INSPECTION/ADJUSTMENT

GEAR OIL CHANGE

Remove the oil filler bolt.
 Remove the oil drains bolt and drain the oil thoroughly.
 Install the oil drain bolt.
Torque: 1 kgf-m (10 N-m, 7.2 lbf-ft)

* Make sure that the sealing washer is in good condition.

Fill with the recommended oil.

Oil Capacity:

At disassembly:
 400 cc (0.352 Imp qt, 0.424 US qt)

At change:

200 cc (0.176 Imp qt, 0.212 US qt)

Reinstall the oil filler bolt and check for oil leaks.

Torque: 1 kgf-m (10 N-m, 7.2 lbf-ft)

DRIVE BELT

Remove the left crankcase cover.
 Inspect the drive belt for cracks, scaling, chipping or excessive wear.
 Measure the V-belt width
Service limit: 17 mm (0.68 in)
 Replace the drive belt if out of specification.



Oil Drain Bolt/ Sealing Washer

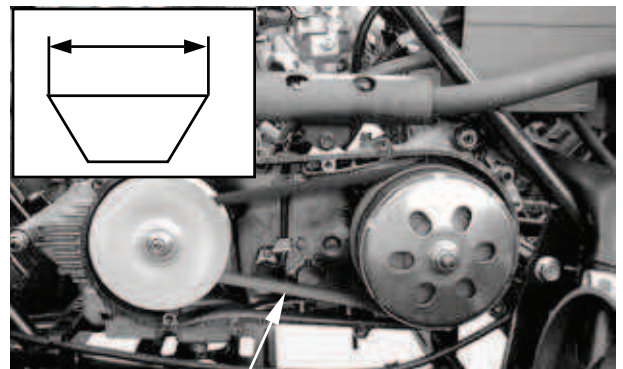

Drive Belt

Wear Indicator

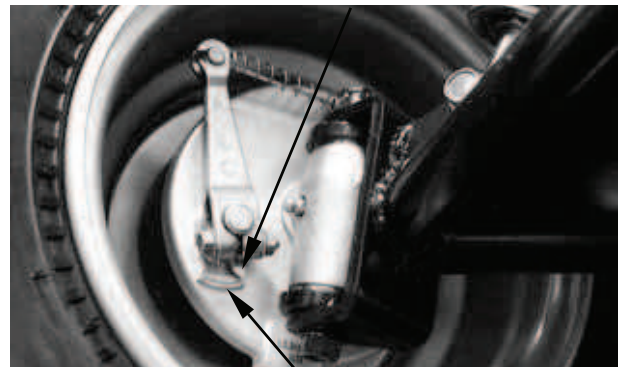

Punch Mark

BRAKE SHOE

Replace the brake shoes if the arrow on the wear indicator plate aligns with the punch mark on the brake panel when the brake is fully applied.

BRAKE SYSTEM

FRONT BRAKE

Measure the front brake lever free play.
Free Play: 10~20 mm (0.4~0.8 in)
 Adjust if out of specification.



3. INSPECTION/ADJUSTMENT

Adjust brake lever free play:

Loosen the lock nuts.

Turn the adjusters in or out until the specified free play is obtained.

Turning adjusters in that the free play is increased.

Turning adjusters out that the free play is decreased.

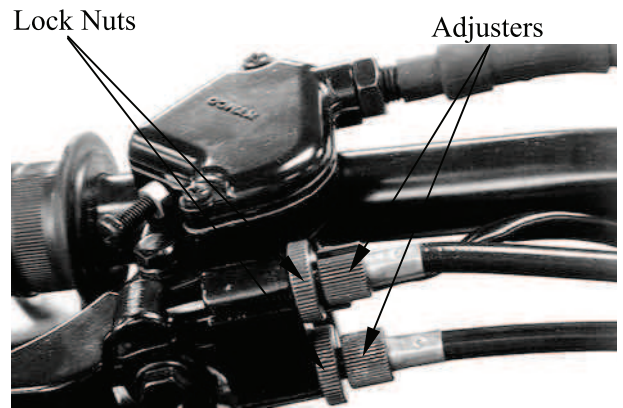

The difference between both clearances should be 2 mm (0.08 in) or less when front brake is applied.

Tighten the lock nuts.

* Make sure that the brake does not drag after adjusting.

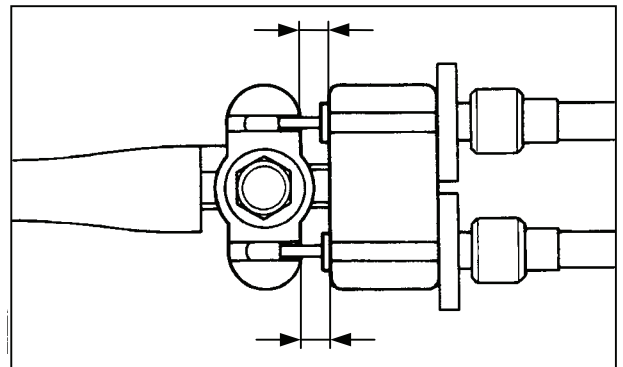

REAR BRAKE

Measure the rear brake lever free play.

Free Play: 10~20 mm (0.4~0.8 in)



If the free play do not fall within the limit, adjust by turning the adjusting nut.

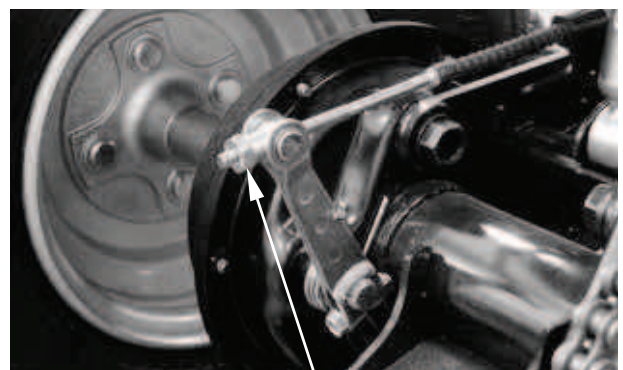

Adjusting Nut

3. INSPECTION/ADJUSTMENT

HEADLIGHT AIM

MX'er 150/125:

Turn the ignition switch ON and start the engine.

Turn on the headlight switch.

Adjust the headlight aim by turning the headlight aim adjusting screw.



Adjusting Screw

MXU 150:

Turn the ignition switch ON and start the engine.

Turn on the headlight switch.

Adjust the headlight aim by turning the headlight aim adjusting screws.

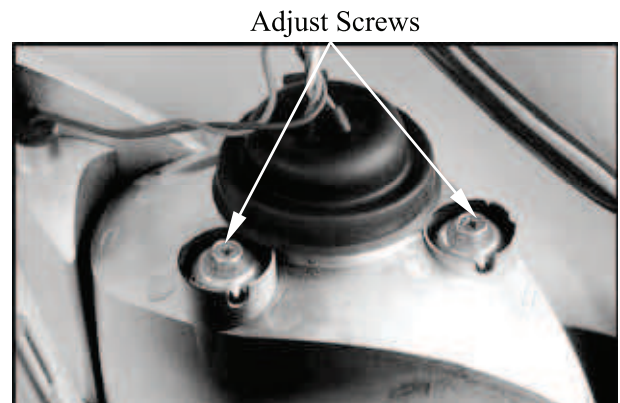

Adjust Screws

3. INSPECTION/ADJUSTMENT

STEERING SYSTEM INSPECTION

Place the machine on a level place.

Check the steering column bushings and bearings:

Move the handlebar up and down, and/or back and forth.

Replace the steering column bushings and or bearings if excessive play



Check the tie-rod ends

Turn the handlebar to the left and/or right until it stops completely, then slightly move the handlebar from left to right.

Replace the tie-rod ends if tie-rod end has any vertical play.

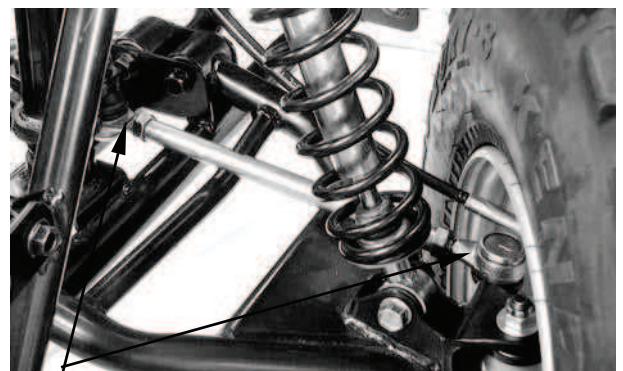

Tie-rod Ends

Raise the front end of the machine so that there is no weight on the front wheels.

Check ball joints and/or wheel bearings.

Move the wheels laterally back and forth.

Replace the front arms and/or wheel bearings if excessive free play.



3. INSPECTION/ADJUSTMENT

TOE-IN ADJUSTMENT

Place the machine on a level place.

Measure the toe-in

Adjust if out of specification.

Toe-in measurement steps:

Mark both front tire tread centers.

Raise the front end of the machine so that there is no weight on the front tires.

Fix the handlebar straight ahead.

Measure the width A between the marks.

Rotate the front tires 180 degrees until the marks come exactly opposite.

Measure the width B between the marks.

Calculate the toe-in using the formula given below.

Toe-in = B – A

Toe-in: 0~15 mm (0~0.6 in)

If the toe-in is incorrect, adjust the toe-in

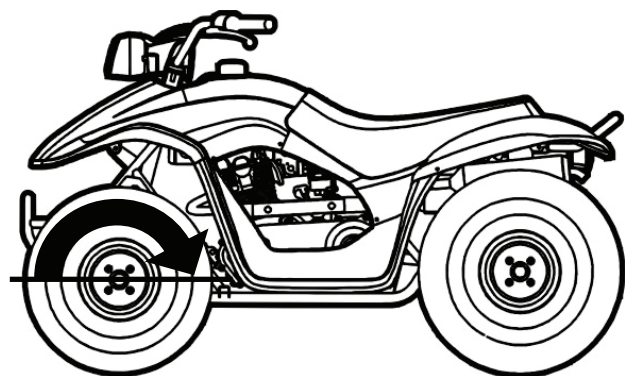
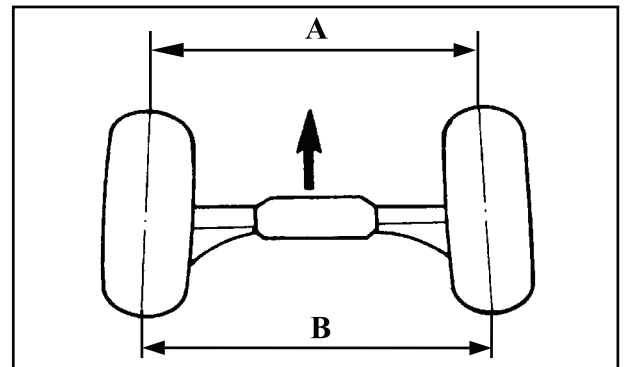

Adjust the toe-in step:

Mark both tie-rod ends.

This reference point will be needed during adjustment.

Loosen the lock nuts (tie-rod end) of both tie-rods

The same number of turns should be given to both tie-rods right and left until the specified toe-in is obtained, so that the lengths of the rods will be kept the same.

Torque: 3 kgf-m (30 N-m, 22 lbf-ft)

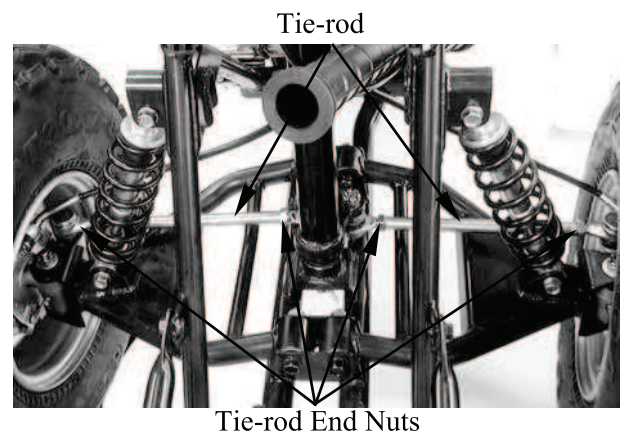

- *
- Be sure that both tie-rod are turned the same amount. If not, the machine will drift tight or left even though the handlebar is positioned straight which may lead to mishandling and accident.
 - After setting the toe-in to specification, run the machine slowly for some distance with hands placed lightly on the handlebar and check that the handlebar responds correctly. If not, turn either the right or left tie-rod within the toe-in specification.

3. INSPECTION/ADJUSTMENT

WHEELS/TIRES

Check the tires for cuts, imbedded nails or other damages.
 Check the tire pressure.

* Tire pressure should be checked when tires are cold.

TIRE PRESSURE

	1 Rider	
	MXU 150	MX'er 150/125
Front	28 kPa (0.28 kgf/cm ² , 3.96 psi)	20 kPa (0.2 kgf/cm ² , 2.84 psi)
Rear	28 kPa (0.28 kgf/cm ² , 3.96 psi)	25 kPa (0.25 kgf/cm ² , 3.55 psi)

TIRE SIZE

MX'er 150/125:

Front : 20*7-8

Rear : 22*10-8

MXU 150:

Front : 21*7-10

Rear : 22*10-10

Check the front axle nut for looseness.
 Check the rear axle nut for looseness.
 If the axle nuts are loose, tighten them to the specified torque.

Torque:

Front: 7 kgf-m (70 N-m, 50 lbt-ft)

Rear : 7 kgf-m (70 N-m, 50 lbt-ft)

WHEEL INSPECTION

Inspect the tire surfaces.
 Replace if wear or damage.

Tire wear limit: 3 mm (0.12 in)

* It is dangerous to ride with a worn out tire. When a tire wear is out of specification, replace the tire immediately.



Front Axle Nut



Rear Axle Nut

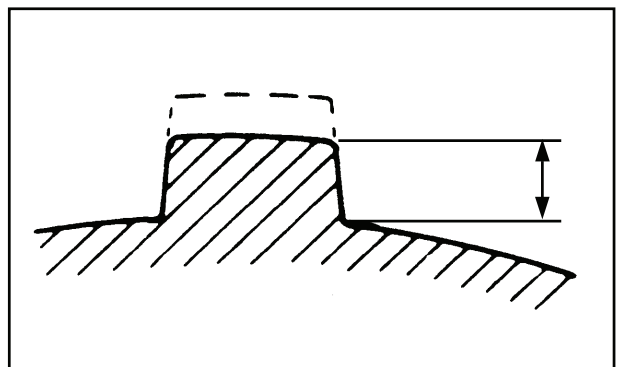

3. INSPECTION/ADJUSTMENT

Inspect the wheel.

Replace if damage or bends

Always balance the wheel when a tire or wheel has been changed or replaced.

- *
 • Never attempt even small repairs to the wheel.
 • Ride conservatively after installing a tire to allow it to seat itself properly on the rim.

DRIVE CHAIN SLACK ADJUSTMENT

Before checking and/or adjusting, rotate the rear wheels several revolutions and check slack at several points to find the tightest point. Check and/or adjust the chain slack with the rear wheels in this “tightest” position.

- *
 Too little of chain slack will overload the engine and other vital parts; keep the slack within the specified limits.

Place the machine on a level place.

- *
 Wheels should be on the ground without the rider on it.

Check drive chain slack.

Adjust if out of specification.

Drive chain slack:

10~20 mm (0.4~0.8 in)

Adjust drive chain slack:

Elevate the rear wheels by placing a suitable stand under the rear of frame.

- *
 Support the machine securely so there is no danger of it falling over.

Loosen four bolts attaching rear axle hub.

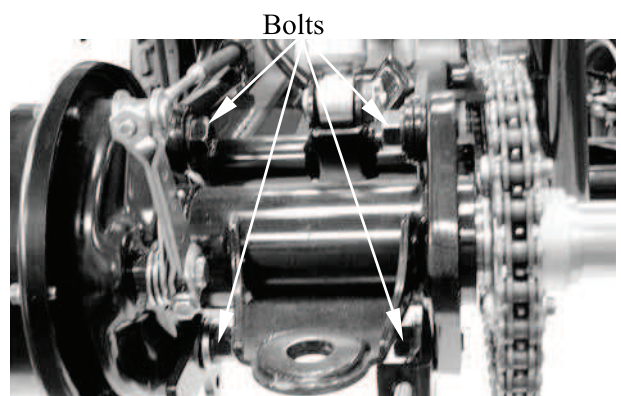

3. INSPECTION/ADJUSTMENT

Turn the adjuster in or out until the specified slack is obtained.

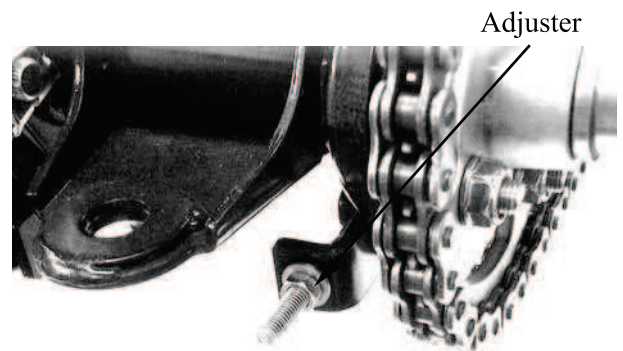

Turn out: Slack is decreased.

Turn in: Slack is increased.



Tighten four bolts attaching rear axle hub to the specification. While pushing up or down on the chain to zero slack.

Torque: 7 kgf-m (70 N-m, 50 lbf-ft)

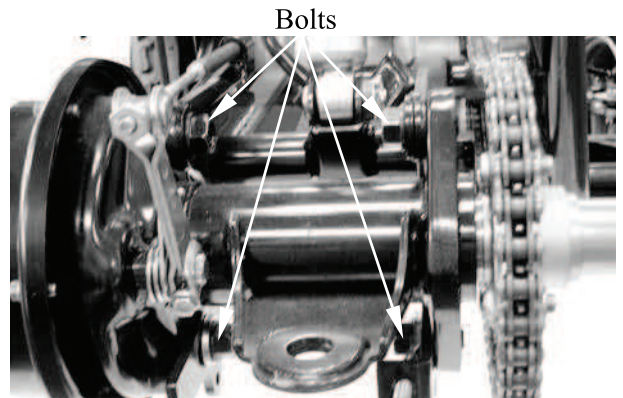

Tighten the adjuster.

Torque: 2.15 kgf-m (21.5 N-m, 15.5 lbf-ft)

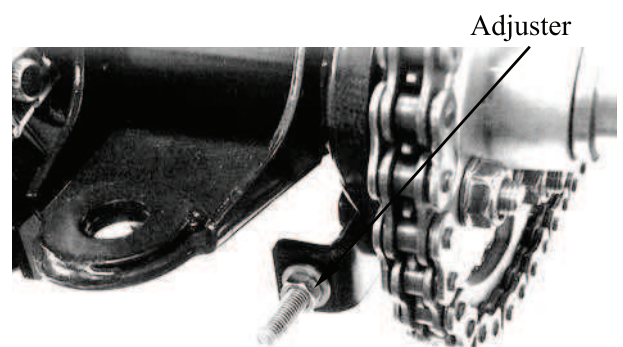

3. INSPECTION/ADJUSTMENT

CABLE INSPECTION AND LUBRICATION

- * Damaged cable sheath may cause corrosion and interfere with the cable movement. An unsafe condition may result so replace such cable as soon as possible.

Inspect the cable sheath.

Replace if damage.

Check the cable operation.

Lubricate or replace if unsmooth operation.

- * Hold cable end high and apply several drops of lubricant to cable.

LEVER LUBRICATION

Lubricate the pivoting parts of each lever.

FRONT SUSPENSION LUBRICATION

Inject grease into the nipples using a grease gun until slight over flow is observed from the thrust covers.

- * Wipe off the excess grease.



Nipple