

PREFACE

This Service Manual describes the technical features and servicing procedures for the KYMCO *AGILITY 50*

Section 1 contains the precautions for all operations stated in this manual. Read them carefully before starting any operation.

Section 2 is the removal/installation procedures for the frame covers which are subject to higher removal/installation frequency during maintenance and servicing operations.

Section 3 describes the inspection/adjustment procedures, safety rules and service information for each part, starting from periodic maintenance.

Sections 6 through 17 give instructions for disassembly, assembly and inspection of engine, chassis frame and electrical equipment.

Most sections start with an assembly or system illustration and troubleshooting for the section. The subsequent pages give detailed procedures for the section.

Our company reserves the right to make any alteration in the design. The information and contents included in this manual may be different from the motorcycle in case specifications are changed.

TABLE OF CONTENTS

	GENERAL INFORMATION	1
	FRAME COVERS/EXHAUST MUFFLER	2
	INSPECTION/ADJUSTMENT	3
	LUBRICATION SYSTEM	4
ENGINE	FUEL SYSTEM	5
	ENGINE REMOVAL/INSTALLATION	6
	CYLINDER HEAD/VALVES	7
	CYLINDER/PISTON	8
	DRIVE AND DRIVEN PULLEYS/KICK STARTER	9
	FINAL REDUCTION	10
	CRANKCASE/CRANKSHAFT	11
CHASSIS	FRONT WHEEL/FRONT BRAKE/ FRONT SUSPENSION	12
	REAR WHEEL /REAR BRAKE /REAR SUSPENSION	13
ELECTRICAL EQUIPMENT	BATTERY/CHARGING SYSTEM/A.C. GENERATOR	14
	IGNITION SYSTEM	15
	STARTING SYSTEM	16
	LIGHTS/INSTRUMENTS/SWITCHES	17

KWANG YANG MOTOR CO., LTD.
OVERSEAS SALES DEPARTMENT
OVERSEAS SERVICE SECTION

1. GENERAL INFORMATION

1

ENGINE SERIAL NUMBER	1- 1	LUBRICATION POINTS.....	1-13
SPECIFICATIONS.....	1- 2	CABLE & HARNESS ROUTING.....	1-15
SERVICE PRECAUTIONS	1- 3	WIRING DIAGRAM	1-20
TORQUE VALUES	1-11	TROUBLESHOOTUNG.....	1-21
SPECIAL TOOLS	1-12		

ENGINE SERIAL NUMBER



AGILITY 50

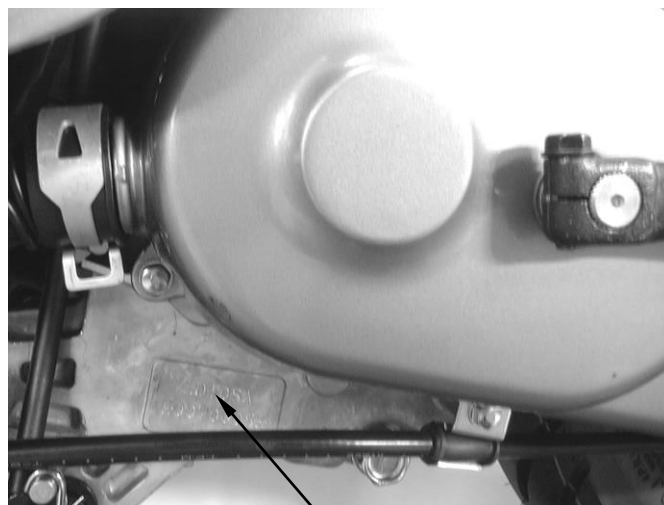

Location of Engine Serial Number

1. GENERAL INFORMATION

AGILITY 50

SPECIFICATIONS-----45km/h

Motorcycle Name & Type		AGILITY 50		
Name & Model No.		KN10A		
Overall length (mm)		1920		
Overall width (mm)		685		
Overall height (mm)		1130 optional: 1150 mm		
Wheel base (mm)		1320		
Engine type		O.H.C.		
Displacement		49.5cc		
Fuel Used		92# nonleaded gasoline		
Net weight (kg)	Front wheel	38		
	Rear wheel	59		
	Total	97		
Gross weight(kg)	Front wheel	76		
	Rear wheel	171		
	Total	247		
Tires	Front wheel	120/70-12 56J		
	Rear wheel	130/70-12 59J		
Ground clearance (mm)		110		
Perform- ance	Braking distance (m)	4 (Initial speed 30km/h)		
	Min. turning radius (mm)	2100/1810		
Engine	Starting system		Starting motor & kick starter	
	Type		Gasoline, 4-stroke	
	Cylinder arrangement		Single cylinder	
	Combustion chamber type		Semi-sphere	
	Valve arrangement		O.H.C.	
	Bore x stroke (mm)		φ39.0 x 41.4	
	Compression ratio		10.5±0.2 : 1	
	Compression pressure (kg/cm ² -rpm)		15±2	
	Max. output		2.2KW/7250(r/min)	
	Max. torque		3.0N.M/7000rpm	
	Port timing	Intake	Open	4°
			Close	12°
		Exhaust	Open	20°
			Close	-8°
	Valve clearance (cold) (mm)	Intake	0.08	
		Exhaust	0.08	
	Idle speed (rpm)		2000±100rpm	
	Lubrication System	Lubrication type		Forced pressure & wet sump
		Oil pump type		Inner/outer rotor type
		Oil filter type		Full-flow filtration
Oil capacity		0.8 liter		
Cooling Type		Forced air cooling		

Fuel System	Air cleaner type & No		Paper element, wet		
	Fuel capacity		5.0L±0.5L		
	Carburetor	Type	CVK		
		Piston dia. (mm)	φ20		
Venturi dia.(mm)		φ17equivalent			
Throttle type		Butterfly type			
Electrical Equipment	Ignition System	Type	E.C.U		
		Ignition timing	12° ~25°		
		Contact breaker	Non-contact point type		
		Spark plug	NGK CR7HSA/CR6HSA		
	Spark plug gap	0.7mm~0.8mm.			
Battery	Capacity	12V6AH			
Power Drive System	Clutch	Type	Dry multi-disc clutch		
		Transmission Gear	Type	Non-stage transmission	
	Operation		Automatic centrifugal type		
	Reduction Gear	Type	Two-stage reduction		
		Reduction ratio	1st	1.04-2.47	
		2nd	18.72		
Moving Device	Front Axle	Caster angle	27°		
		Trail length	—		
	Tire pressure (kg/cm ²)	Front	1.75		
		Rear	2.25		
	Turning angle	Left	45°		
Right		45°			
Brake system type	Front	DISK (180 mm) brake			
	Rear	Drum (110mm) brake			
Damping Device	Suspension type	Front	TELESCOPE		
		Rear	Under Swing		
	Shock absorber distance	Front	80		
		Rear	82		
Frame type		Under Bone			

1. GENERAL INFORMATION

SPECIFICATIONS -----25km/h

Motorcycle Name & Type		AGILITY 50		
Name & Model No.		KN10A		
Overall length (mm)		1920		
Overall width (mm)		685		
Overall height (mm)		1130 optional: 1150 mm		
Wheel base (mm)		1320		
Engine type		O.H.C.		
Displacement		49.5cc		
Fuel Used		92# nonleaded gasoline		
Net weight (kg)	Front wheel	38		
	Rear wheel	59		
	Total	97		
Gross weight(kg)	Front wheel	76		
	Rear wheel	171		
	Total	247		
Tires	Front wheel	120/70-12 56J		
	Rear wheel	130/70-12 59J		
Ground clearance (mm)		110		
Performance	Braking distance (m)	4 (Initial speed 30km/h)		
	Min. turning radius (mm)	2100/1810		
Engine	Starting system		Starting motor & kick starter	
	Type		Gasoline, 4-stroke	
	Cylinder arrangement		Single cylinder	
	Combustion chamber type		Semi-sphere	
	Valve arrangement		O.H.C.	
	Bore x stroke (mm)		φ39.0 x 41.4	
	Compression ratio		10.5±0.2 : 1	
	Compression pressure (kg/cm ² -rpm)		15±2	
	Max. output		2.0KW/7000(r/min)	
	Max. torque		2.7N.M/6500rpm	
	Port timing	Intake	Open	4°
			Close	12°
		Exhaust	Open	20°
			Close	-8°
	Valve clearance (cold) (mm)	Intake	0.08	
		Exhaust	0.08	
	Idle speed (rpm)		2000±100rpm	
	Lubrication System	Lubrication type		Forced pressure & wet sump
		Oil pump type		Inner/outer rotor type
		Oil filter type		Full-flow filtration
Oil capacity		0.8 liter		
Cooling Type		Forced air cooling		

Fuel System	Air cleaner type & No		Paper element, wet		
	Fuel capacity		5.0L±0.5L		
	Carburetor	Type	CVK		
		Piston dia. (mm)	φ20		
Venturi dia.(mm)		φ17equivalent			
Throttle type		Butterfly type			
Electrical Equipment	Ignition System	Type	E.C.U		
		Ignition timing	12°~25°		
		Contact breaker	Non-contact point type		
		Spark plug	NGK CR7HSA/CR6HSA		
		Spark plug gap	0.7mm~0.8mm.		
Battery	Capacity	12V6AH			
Power Drive System	Clutch	Type	Dry multi-disc clutch		
		Transmission Gear	Type	Non-stage transmission	
	Operation		Automatic centrifugal type		
	Reduction Gear		Type	Two-stage reduction	
		Reduction ratio	1st	1.69-2.68	
2nd	18.72				
Moving Device	Front Axle	Caster angle	27°		
		Trail length	—		
	Tire pressure (kg/cm ²)	Front	1.75		
		Rear	2.25		
	Turning angle	Left	45°		
Right		45°			
Brake system type	Front	DISK (180 mm) brake			
	Rear	Drum (110mm) brake			
Damping Device	Suspension type	Front	TELESCOPE		
		Rear	Under Swing		
	Shock absorber distance	Front	80		
		Rear	82		
Frame type		Under Bone			

1. GENERAL INFORMATION

SERVICE PRECAUTIONS

- Make sure to install new gaskets, O-rings, circlips, cotter pins, etc. when reassembling.

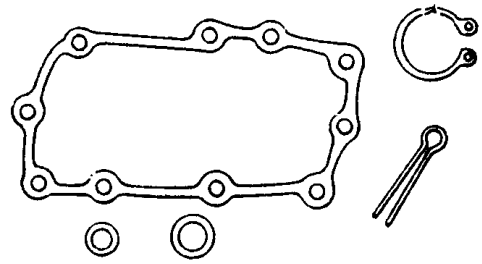

- When tightening bolts or nuts, begin with larger-diameter to smaller ones at several times, and tighten to the specified torque diagonally.

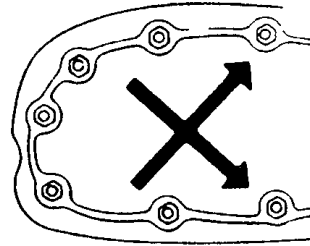

- Use genuine parts and lubricants

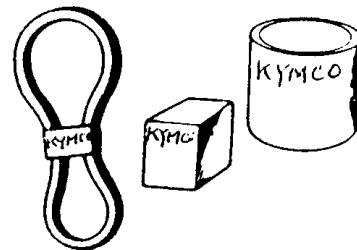

- When servicing the motorcycle, be sure to use special tools for removal and installation.

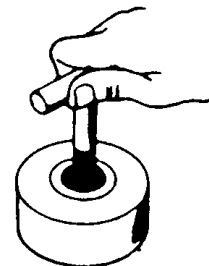

- After disassembly, clean removed parts. Lubricate sliding surfaces with engine oil before reassembly.

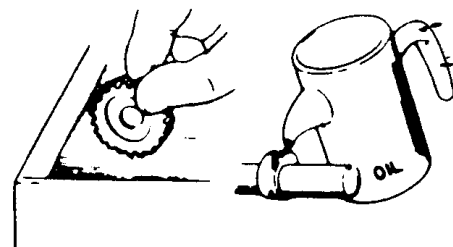

1. GENERAL INFORMATION

- Apply or add designated greases and lubricants to the specified lubrication points.

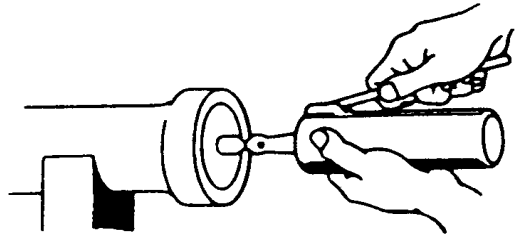

- After reassembly, check all parts for proper tightening and operation.

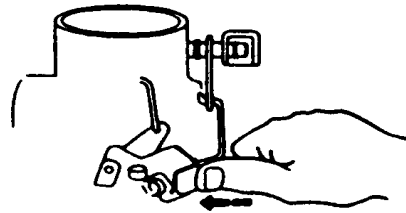

- When two persons work together, pay attention to the mutual working safety.

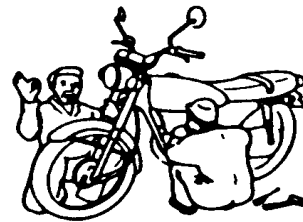

- Disconnect the battery negative (-) terminal before operation.
- When using a spanner or other tools, make sure not to damage the motorcycle surface.

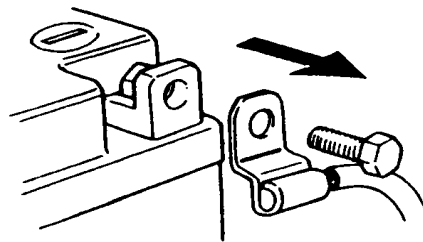

- After operation, check all connecting points, fasteners, and lines for proper connection and installation.
- When connecting the battery, the positive (+) terminal must be connected first.
- After connection, apply grease to the battery terminals.
- Terminal caps shall be installed securely.

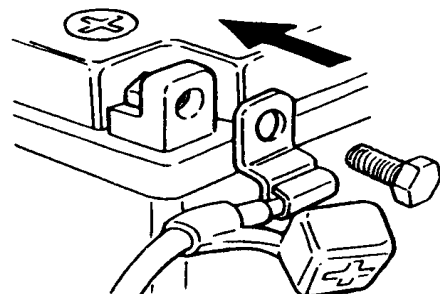

1. GENERAL INFORMATION

- If the fuse is burned out, find the cause and repair it. Replace it with a new one according to the specified capacity.

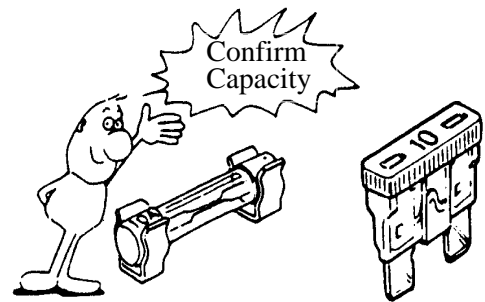

- After operation, terminal caps shall be installed securely.

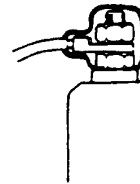

- When taking out the connector, the lock on the connector shall be released before operation.

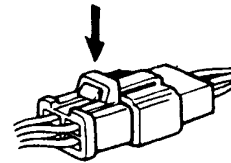

- Hold the connector body when connecting or disconnecting it.
- Do not pull the connector wire.



- Check if any connector terminal is bending, protruding or loose.

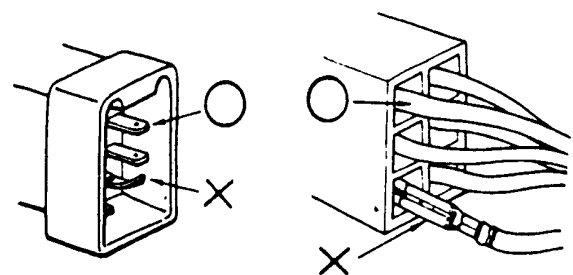

1. GENERAL INFORMATION

- The connector shall be inserted completely.
- If the double connector has a lock, lock it at the correct position.
- Check if there is any loose wire.

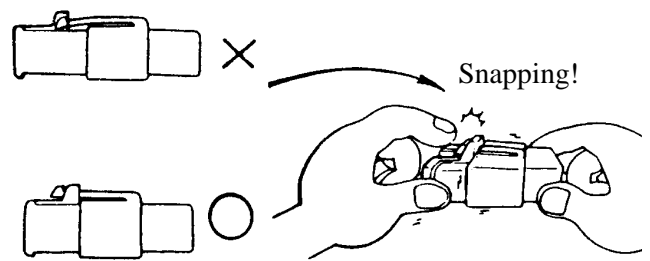

- Before connecting a terminal, check for damaged terminal cover or loose negative terminal.

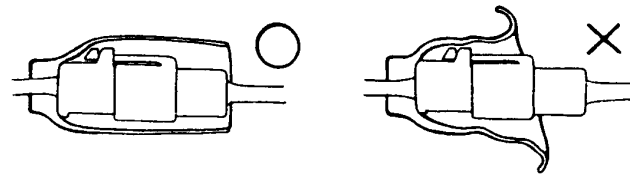

- Check the double connector cover for proper coverage and installation.

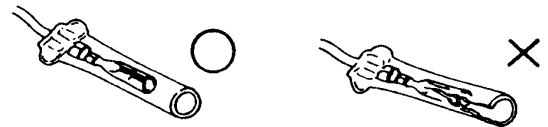

- Insert the terminal completely.
- Check the terminal cover for proper coverage.
- Do not make the terminal cover opening face up.

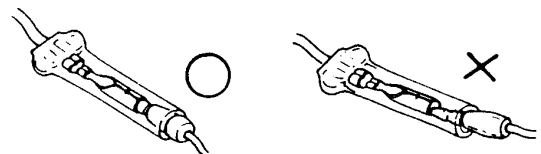

- Secure wire harnesses to the frame with their respective wire bands at the designated locations. Tighten the bands so that only the insulated surfaces contact the wire harnesses.

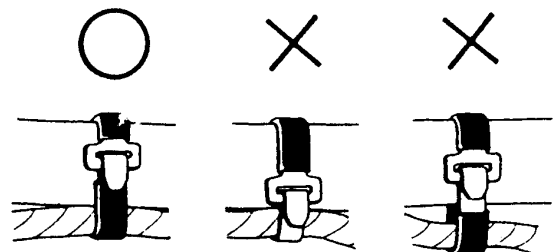

1. GENERAL INFORMATION

- After clamping, check each wire to make sure it is secure.

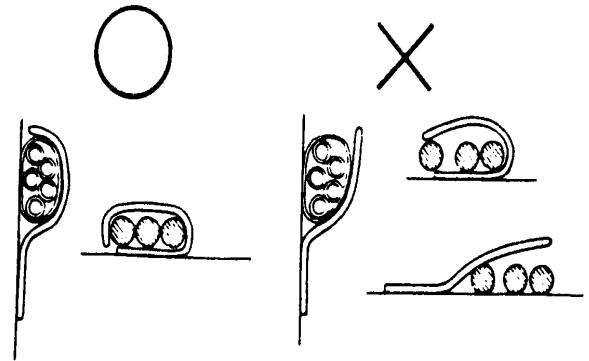

- Do not squeeze wires against the weld or its clamp



- After clamping, check each harness to make sure that it is not interfering with any moving or sliding parts.

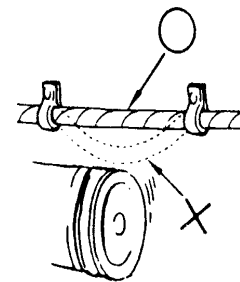

- When fixing the wire harnesses, do not make it contact the parts which will generate high heat.

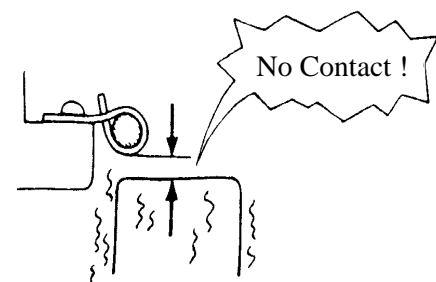

- Route wire harnesses to avoid sharp edges or corners. Avoid the projected ends of bolts and screws.
- Route wire harnesses passing through the side of bolts and screws. Avoid the projected ends of bolts and screws.

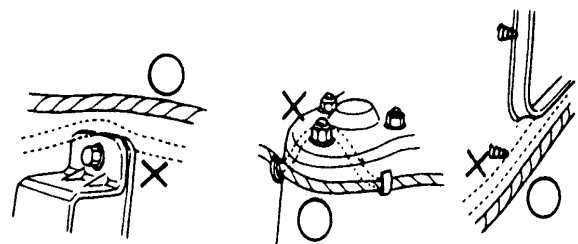

1. GENERAL INFORMATION

- Route harnesses so they are neither pulled tight nor have excessive slack.

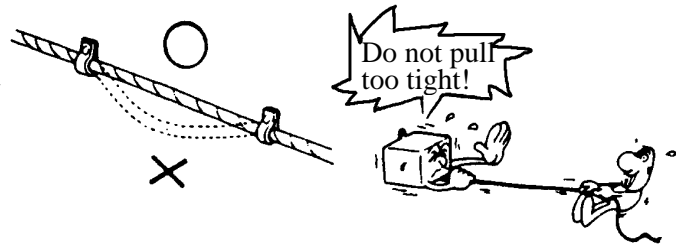

- Protect wires and harnesses with electrical tape or tube if they contact a sharp edge or corner

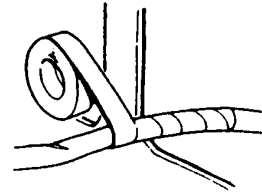

- When rubber protecting cover is used to protect the wire harnesses, it shall be installed securely.

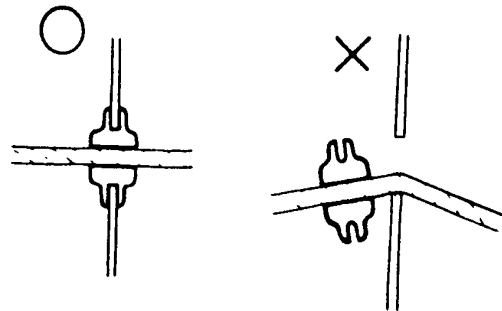

- Do not break the sheath of wire.
- If a wire or harness is with a broken sheath, repair by wrapping it with protective tape or replace it.

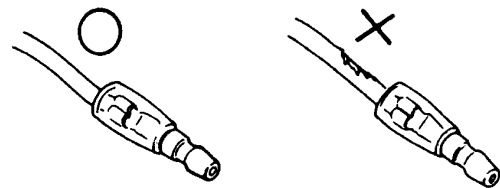

- When installing other parts, do not press or squeeze the wires.



1. GENERAL INFORMATION

- After routing, check that the wire harnesses are not twisted or kinked.

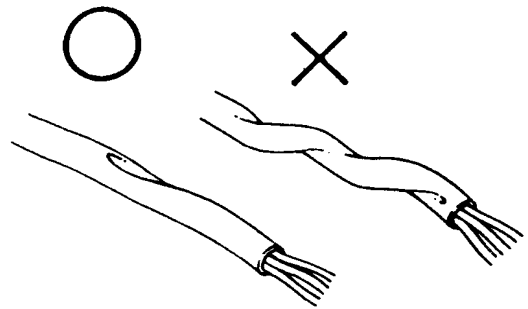

- Wire harnesses routed along with handlebar should not be pulled tight, have excessive slack or interfere with adjacent or surrounding parts in all steering positions.

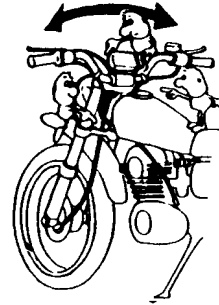

- When a testing device is used, make sure to understand the operating methods thoroughly and operate according to the operating instructions.

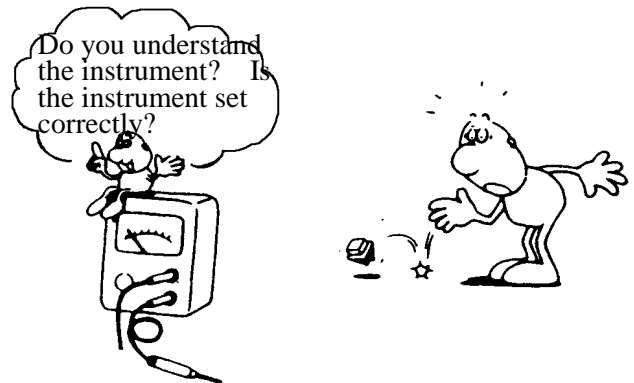

- Be careful not to drop any parts.

- When rust is found on a terminal, remove the rust with sand paper or equivalent before connecting.

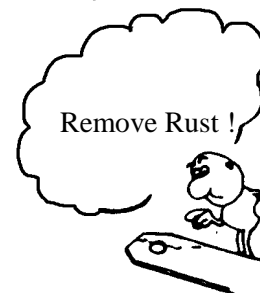

- Do not bend or twist control cables. Damaged control cables will not operate smoothly and may stick or bind.

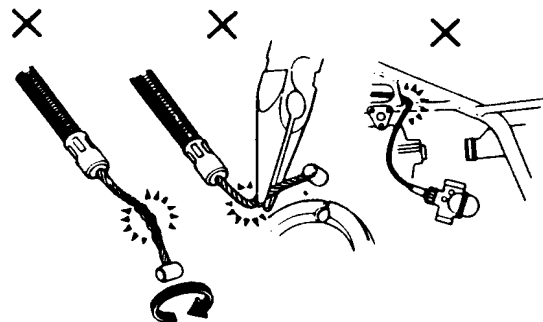

1. GENERAL INFORMATION

■ Symbols:

The following symbols represent the servicing methods and cautions included in this service manual.



Engine Oil

: Apply engine oil to the specified points. (Use designated engine oil for lubrication.)



Grease

: Apply grease for lubrication.



Gear Oil

: Transmission Gear Oil (90#)



: Use special tool.



: Caution



: Warning

(⇒12-3) : Refer to page 12-3.

1. GENERAL INFORMATION

TORQUE VALUES

STANDARD TORQUE VALUES

Item	Torque (kg-m)	Item	Torque (kg-m)
5mm bolt, nut	0.45-0.6	5mm screw	0.35-0.5
6mm bolt, nut	0.6-1.2	6mm screw, SH bolt	0.7-1.1
8mm bolt, nut	1.8-2.5	6mm flange bolt, nut	1.0-1.4
10mm bolt, nut	3.0-4.0	8mm flange bolt, nut	2.4-3.0
12mm bolt, nut	5.0-6.0	10mm flange bolt, nut	3.5-4.5

Torque specifications listed below are for important fasteners.

ENGINE

Item	Q'ty	Thread dia.(mm)	Torque (kg-m)	Remarks
Cylinder head bolt A	2	6	0.7-1.1	Double end bolt
Cylinder head bolt B	4	6	0.7-1.1	
Oil filter screen cap	1	30	1.0-2.0	Double end bolt Apply oil to threads
Exhaust muffler lock bolt	2	6	0.7-1.1	
Cylinder head flange nut	4	7	1.2-1.6	
Valve adjusting lock nut	2	3	0.07-0.09	
Cam chain tensioner slipper bolt	1	8	0.4-0.7	
Oil bolt	1	8	1.1-1.5	
Clutch outer nut	1	10	3.5-4.5	
Clutch drive plate nut	1	28	5.0-6.0	
Starter motor mounting bolt	2	6	0.8-1.2	
Oil pump bolt	3	4	0.1-0.3	
Drive face nut	1	10	5.5-6.5	
Spark plug	1	10	1.0-1.4	
A.C. generator stator bolt	2	6	0.8-1.2	
Cam chain tensioner bolt	1	6	0.8-1.2	

FRAME

Item	Q'ty	Thread dia.(mm)	Torque (kg-m)	Remarks
Steering stem lock nut	1	25.4	8.0-12.0	U-nut
Front axle nut	1	10	5.0-7.0	U-nut
Rear axle nut	1	14	11.0-13.0	U-nut
Rear shock absorber upper bolt	1	10	4.0-5.0	Apply locking agent
Rear shock absorber lower bolt	1	8	2.0-3.0	
Speedometer cable set screw	1	5	0.45-0.6	
Rear shock absorber lock nut	1	8	3.0-3.6	

SPECIAL TOOLS

Tool Name	Tool No.	Remarks	Ref. Page
Bearing puller 10.12.15.18 mm	E037	10.12.15.18mm bearing	10-3 10-4 12-6
Bushing remover L	E032	11102 bush engine hanger rubber	
Bushing remover S	EO19	11203 bush rear cushion under rubber	
Crankshaft bearing puller	E030	91005 radial bearing	
Crankshaft protector	E029	13000 crankshaft comp 12mm.14mm	
Clutch spring compressor	E027	2301a driven pully assy	9-9 9-12
Cushion assemble & disassemble tool	F004	52400 cushion assy	13-4
Flywheel holder	E017	31110 flywheel comp.2310a pully assy driven	9-5 9-9 9-13 14-7 14-9
Flywheel puller	E002	Left hand thread 27mm	14-7
Long socket wrench 32mm 8angle	F002	50306 steering stem	12-21 12-22
Oil seal & bearing installer	E014	Oil seal & bearing install	
Tool boox	E033	Special tools storage	
Tappet adjuster	E036	90012 screw tappet	3-5
Valve spring compressor	E038	Valve spring	7-7 7-8

1. GENERAL INFORMATION

LUBRICATION POINTS

ENGINE

Lubrication Points	Lubricant
Valve guide/valve stem movable part Cam lobes Valve rocker arm friction surface Cam chain Cylinder lock bolt and nut Piston surroundings and piston ring grooves Piston pin surroundings Cylinder inside wall Connecting rod/piston pin hole Connecting rod big end Crankshaft R/L side oil seal Starter reduction gear engaging part Countershaft gear engaging part Final gear engaging part Bearing movable part O-ring face Oil seal lip	<ul style="list-style-type: none"> •Genuine KYMCO Engine Oil (SAE15W-40) •API-SG Engine Oil
Starter idle gear Friction spring movable part/shaft movable part Shaft movable grooved part Kick starter spindle movable part	High-temperature resistant grease
A.C. generator connector Transmission case breather tube	Adhesive

1. GENERAL INFORMATION

FRAME

The following is the lubrication points for the frame.

Use general purpose grease for parts not listed.

Apply clean engine oil or grease to cables and movable parts not specified.

This will avoid abnormal noise and rise the durability of the motorcycle.

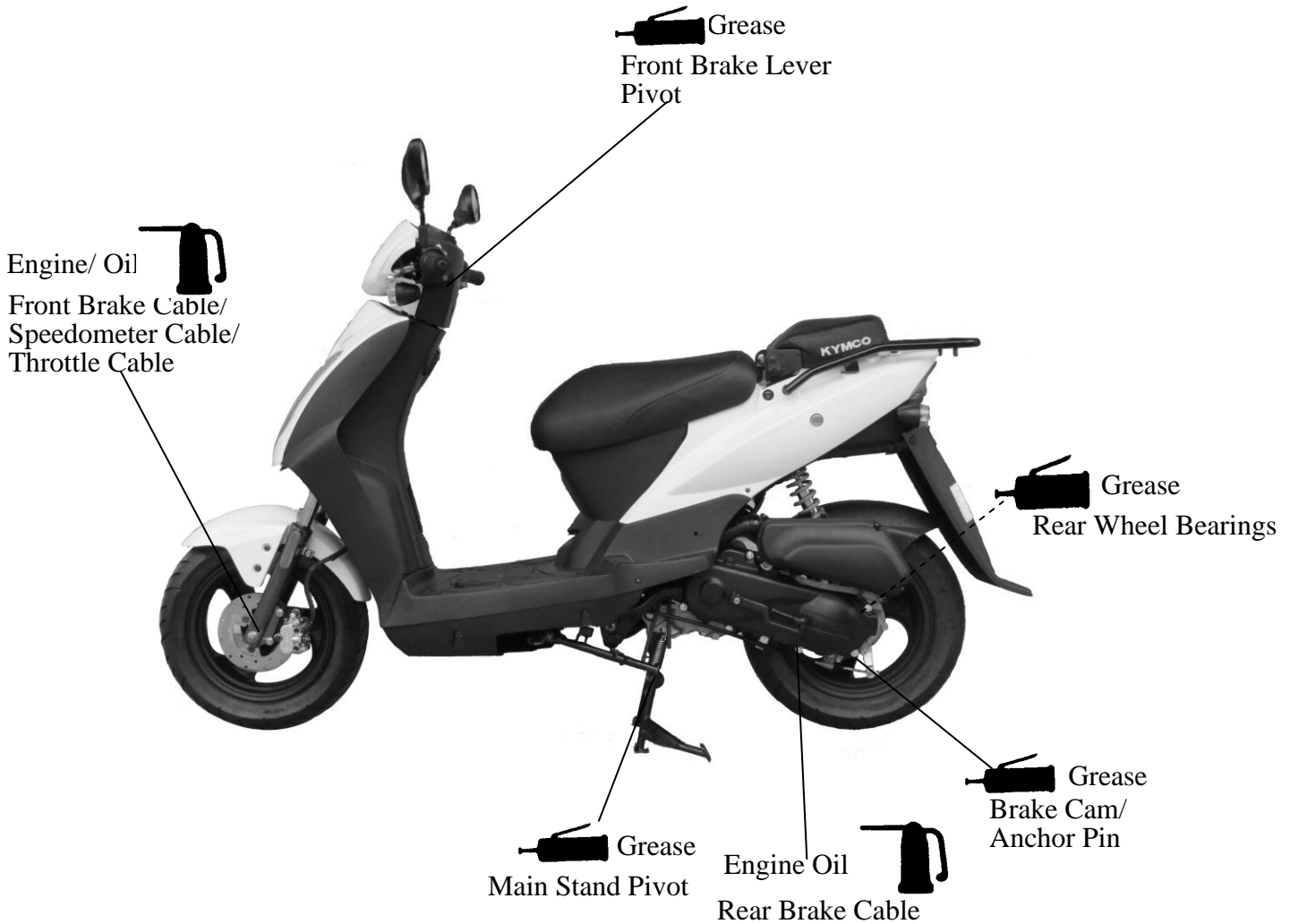

1. GENERAL INFORMATION

CABLE & HARNESS ROUTING

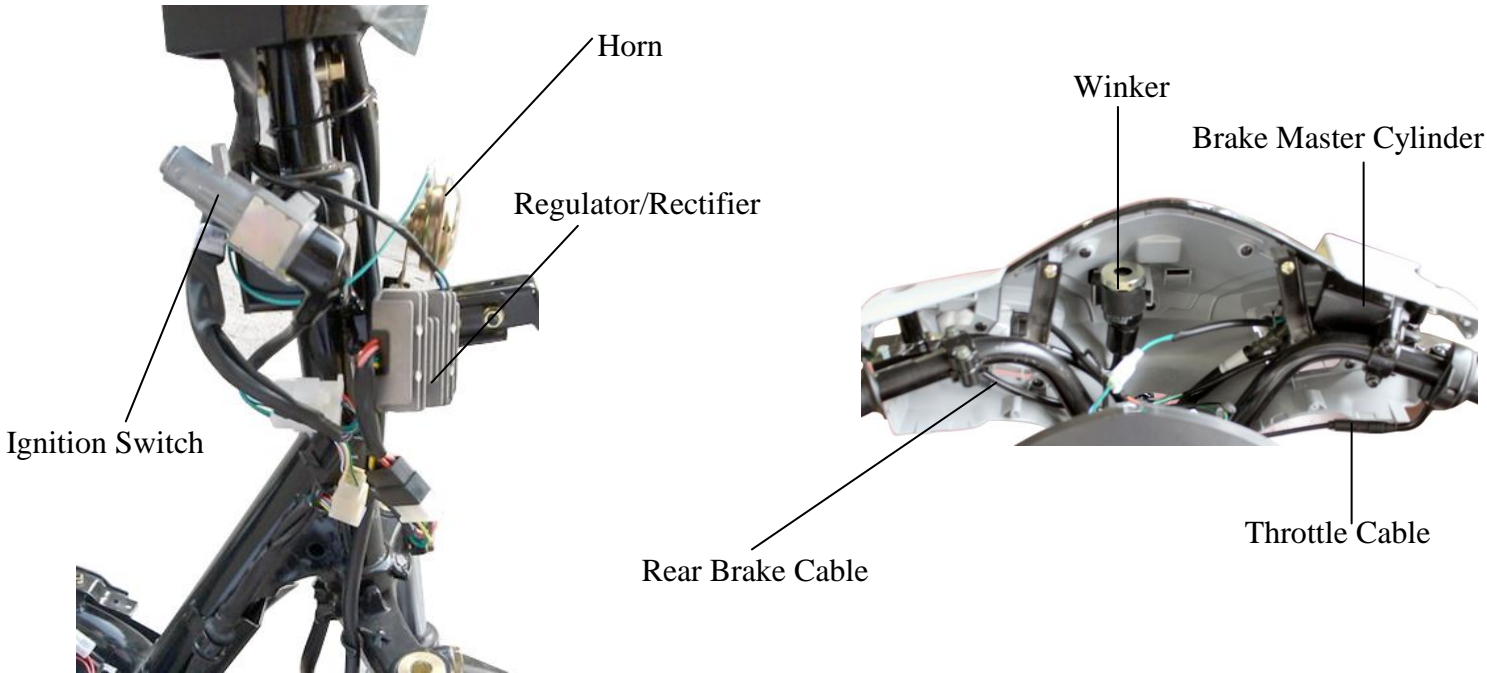
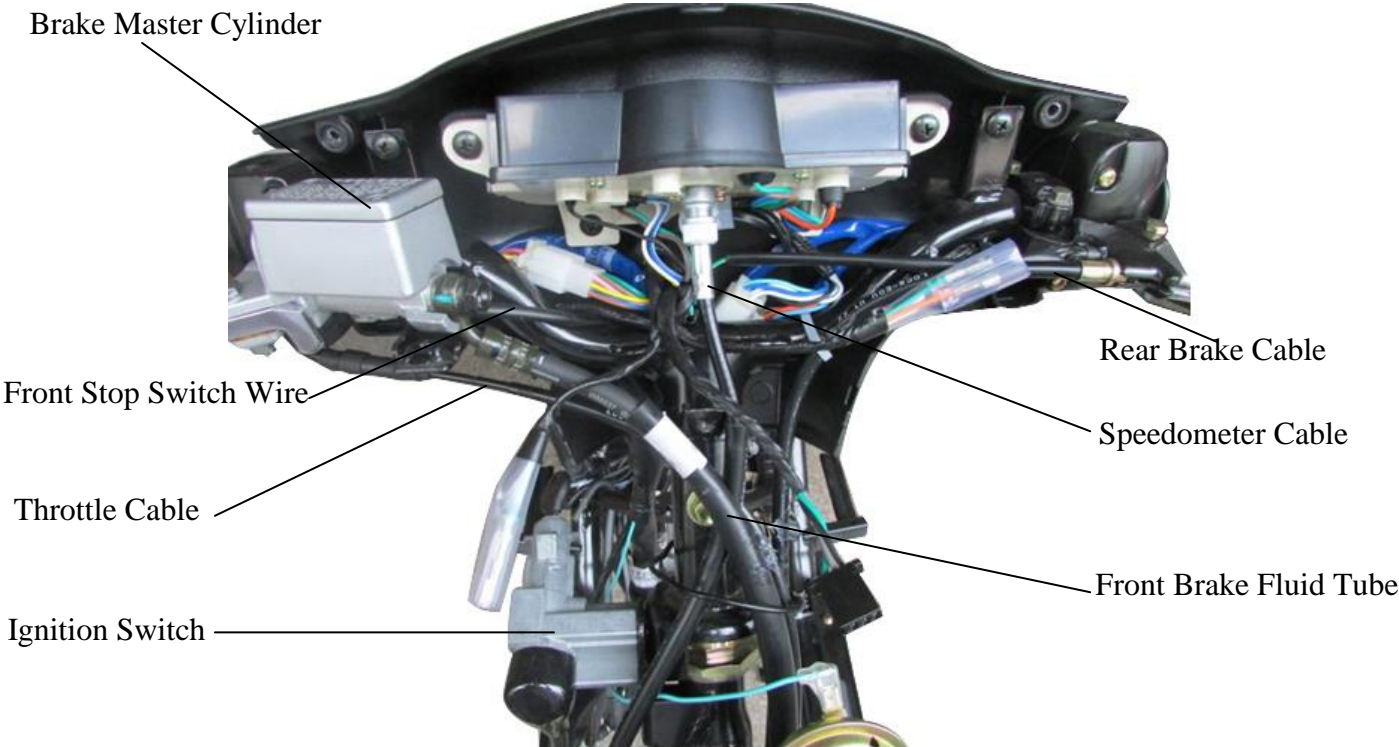

1. GENERAL INFORMATION



Battery (+) Cable

Battery (-) Cable

Diagnostic tool connector

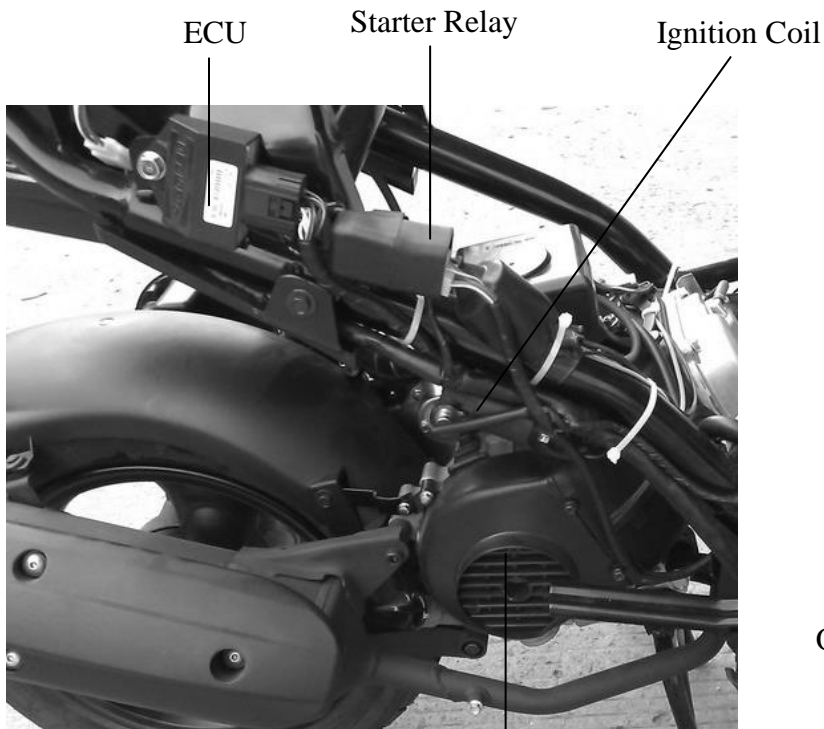

ECU

Starter Relay

Ignition Coil

O2 Sensor

AC Generator

1. GENERAL INFORMATION

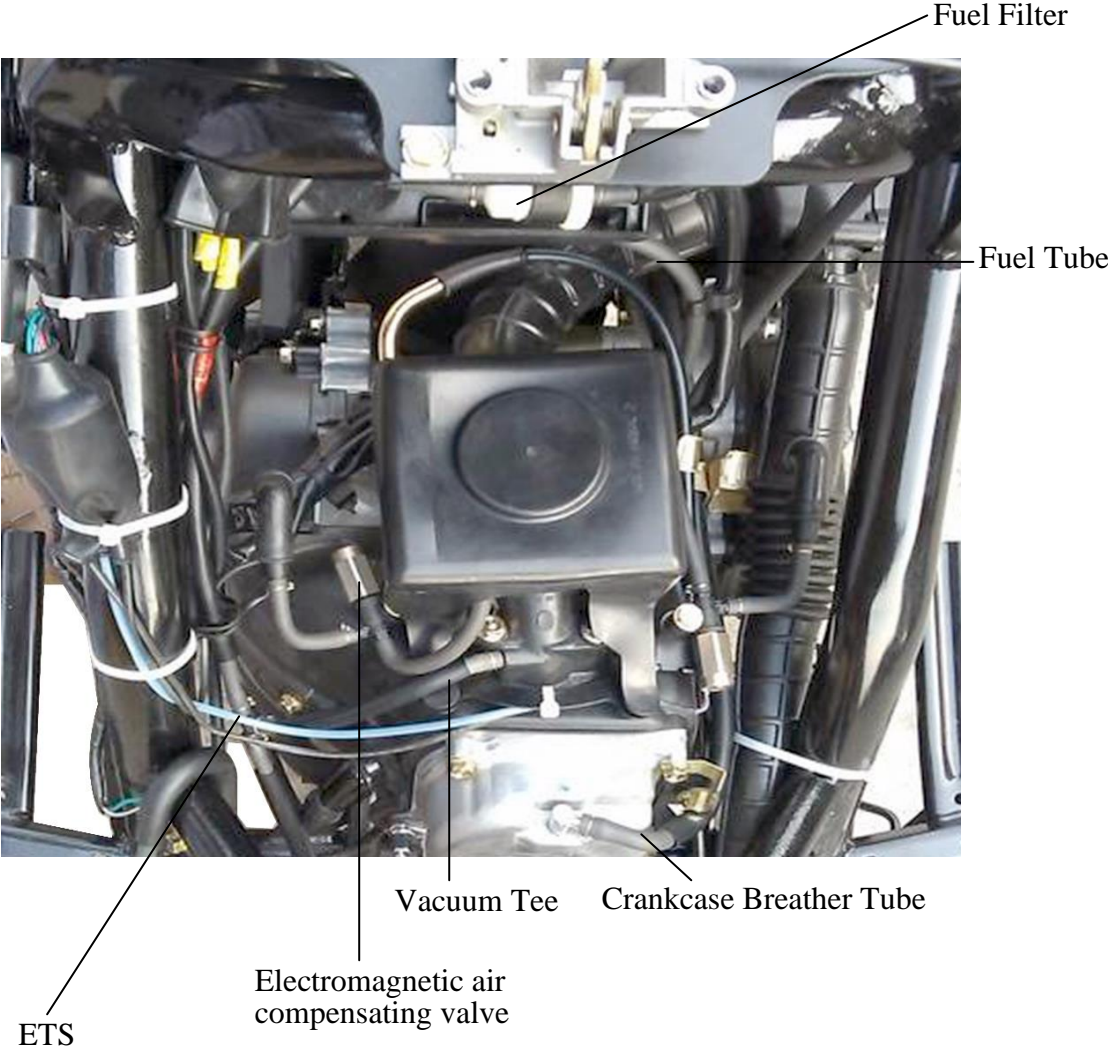

1. GENERAL INFORMATION

TROUBLESHOOTING

ENGINE WILL NOT START OR IS HARD TO START

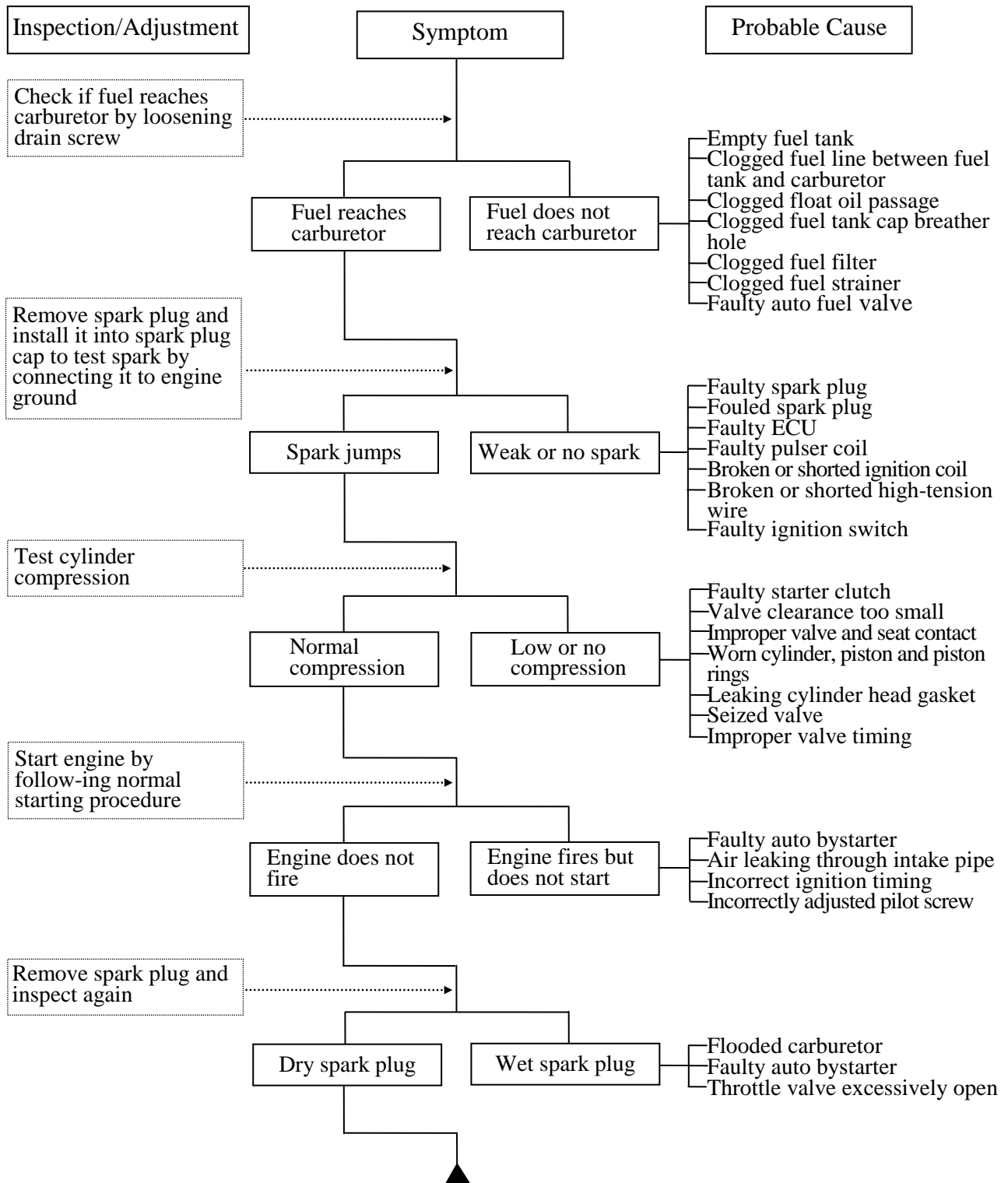

1. GENERAL INFORMATION

ENGINE LACKS POWER

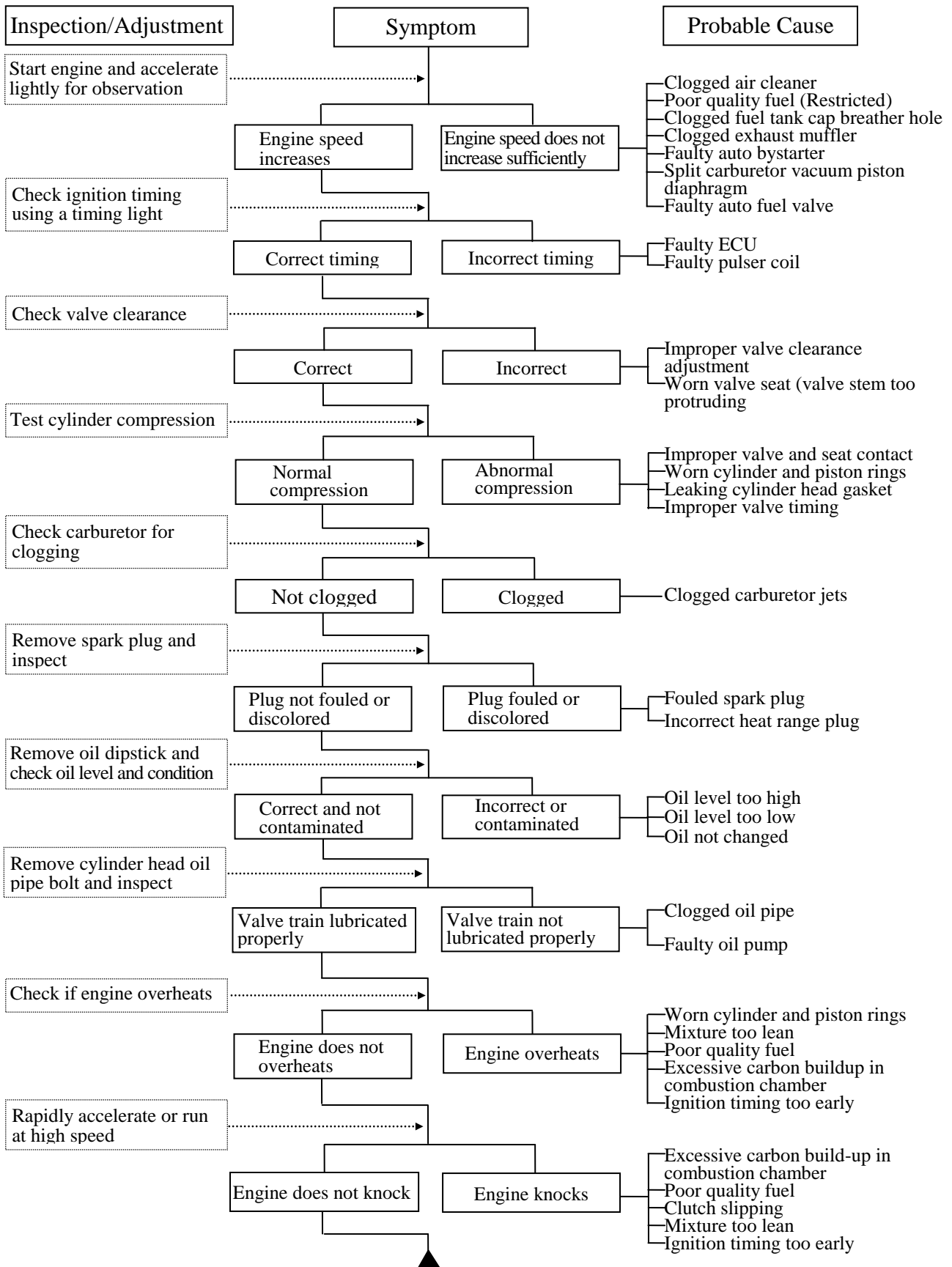

1. GENERAL INFORMATION

AGILITY 50

POOR PERFORMANCE (ESPECIALLY AT IDLE AND LOW SPEEDS)

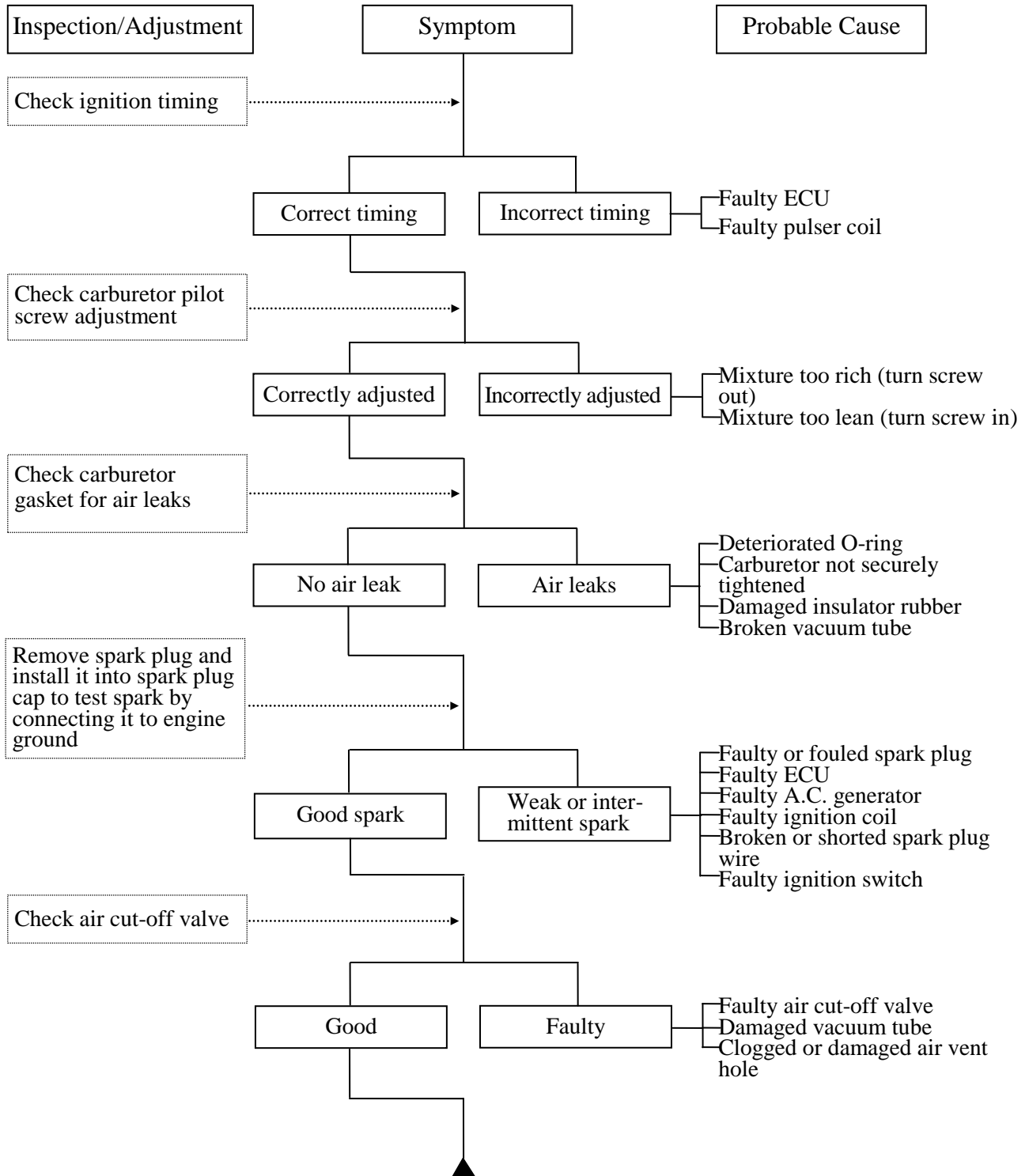

1. GENERAL INFORMATION

POOR PERFORMANCE (AT HIGH SPEED)

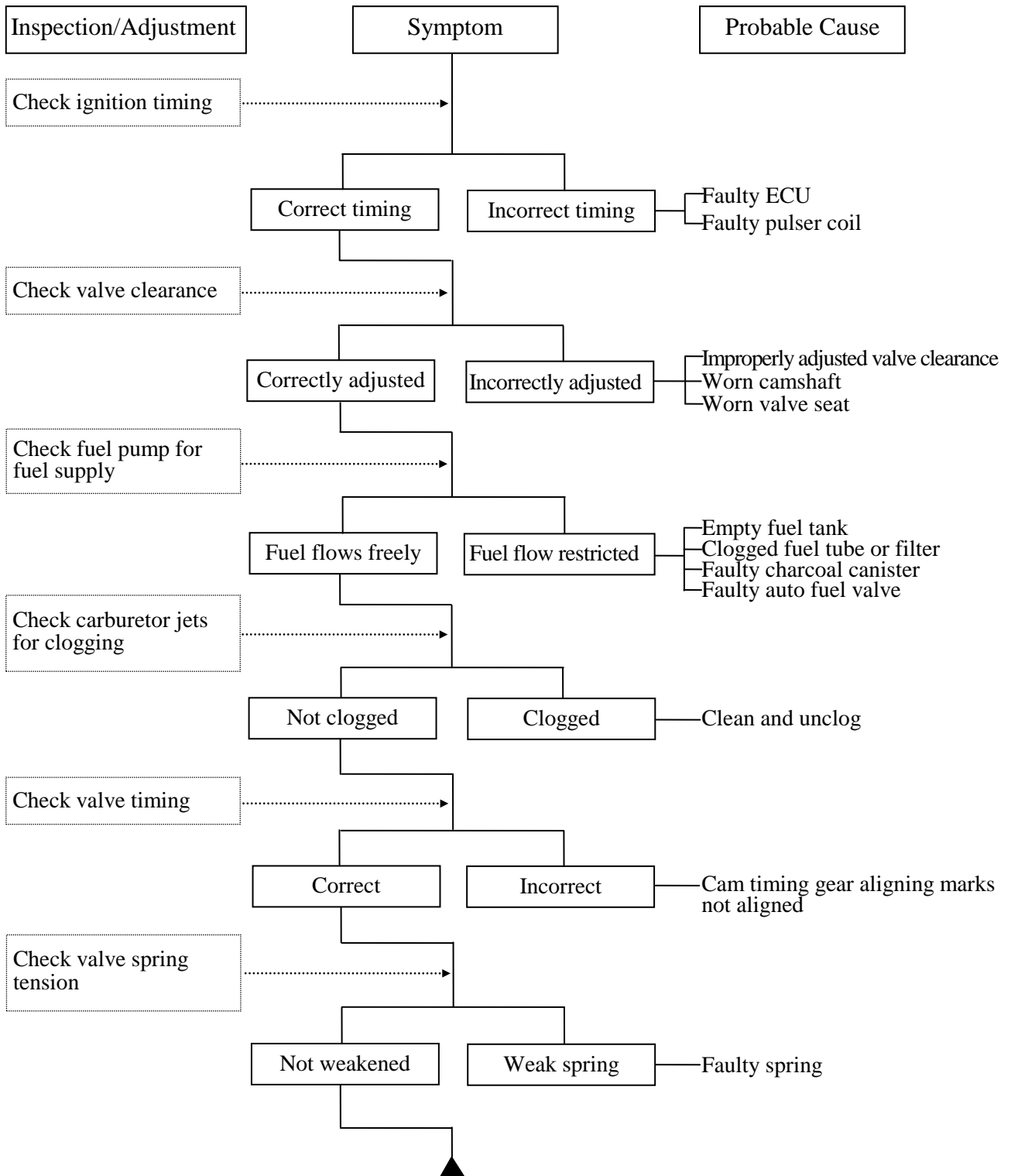

1. GENERAL INFORMATION

POOR CHARGING (BATTERY OVER DISCHARGING OR OVERCHARGING)

Undercharging

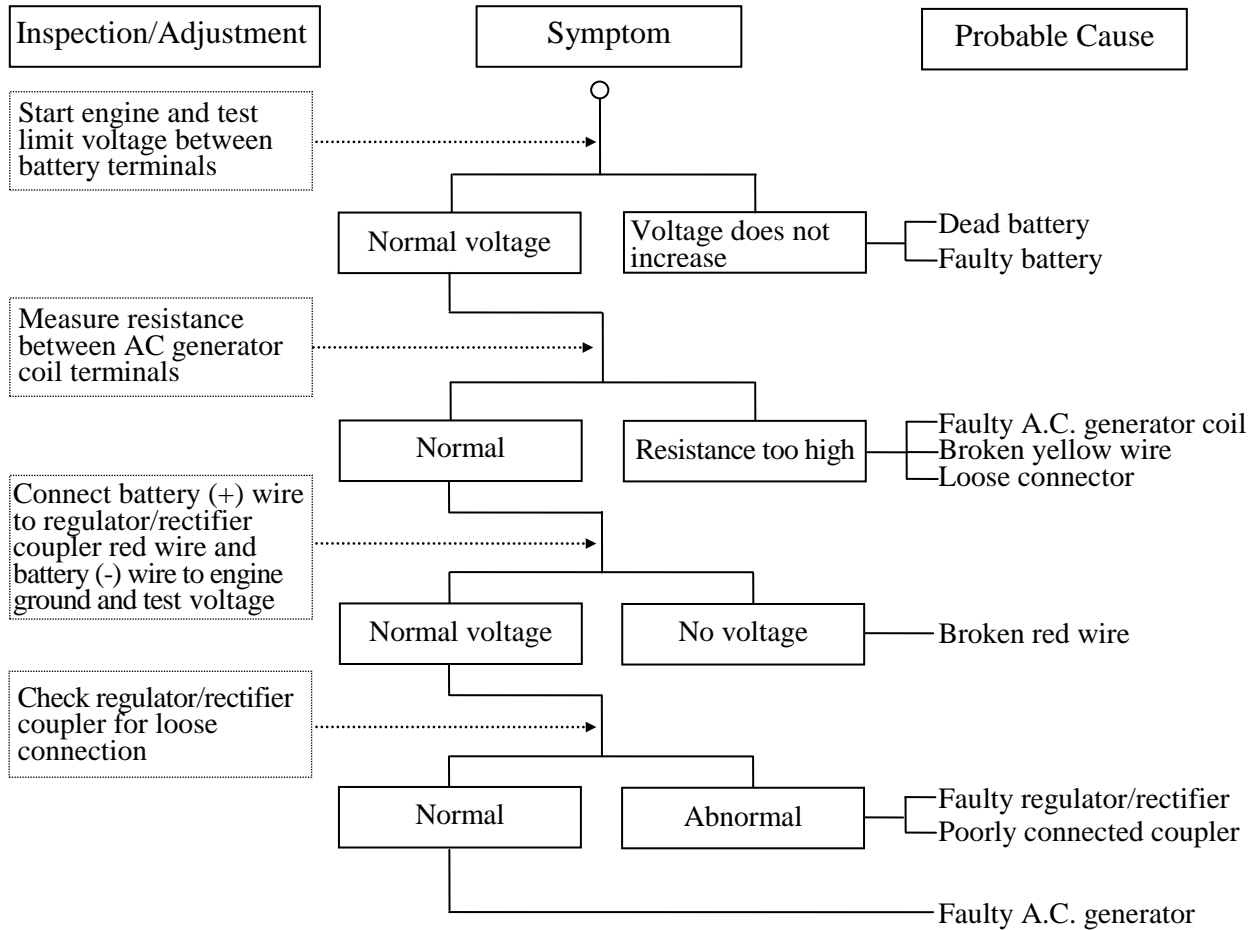

Overcharging

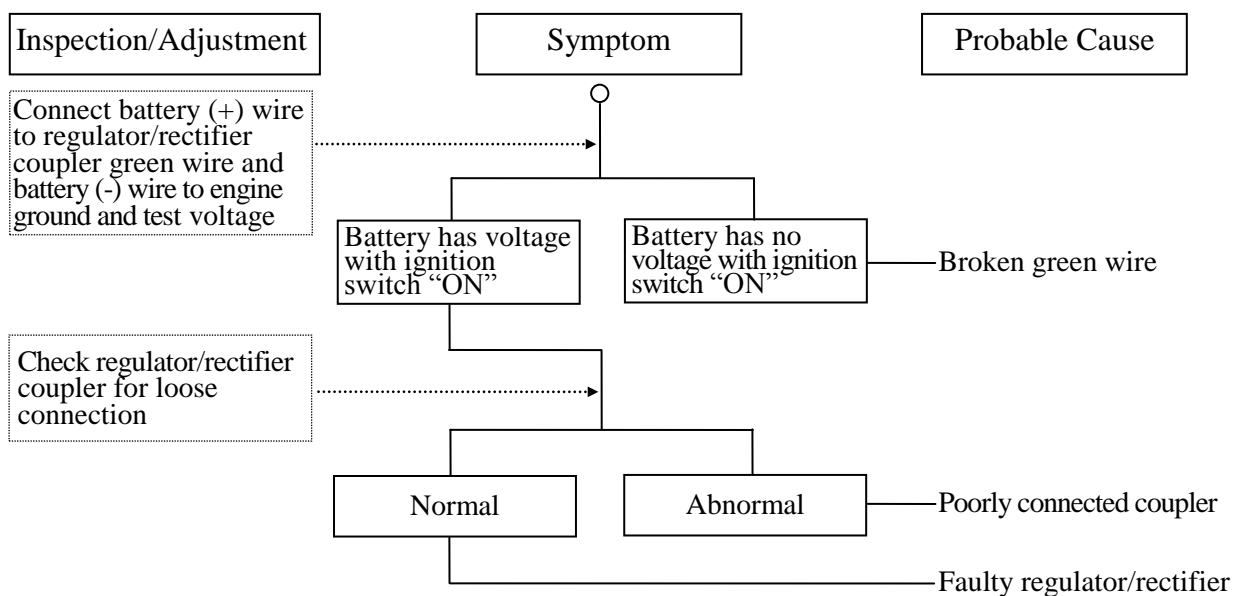

1. GENERAL INFORMATION

NO SPARK AT SPARK PLUG

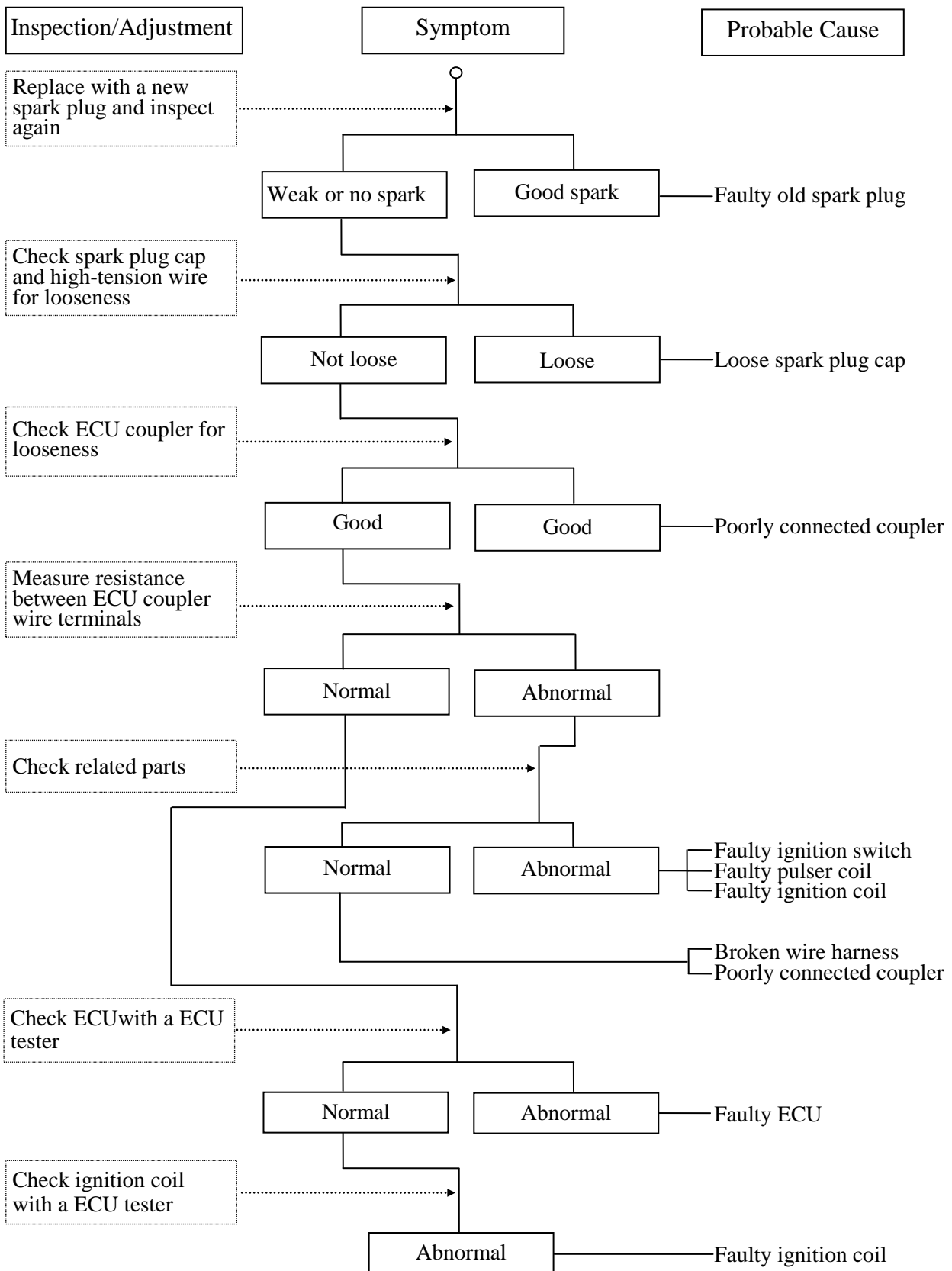

2. FRAME COVERS/EXHAUST MUFFLER

SCHEMATIC DRAWING

2

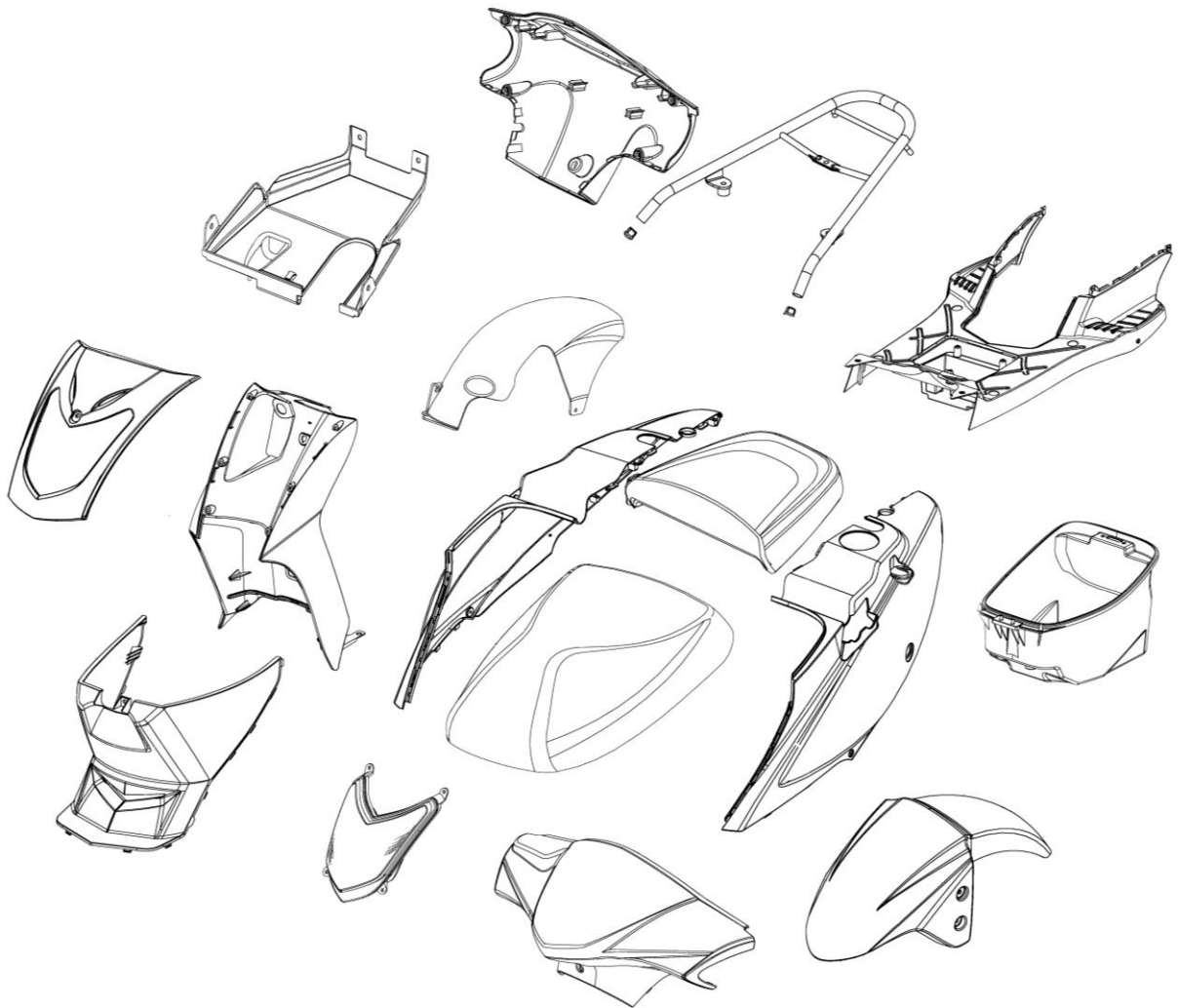

2. FRAME COVERS/EXHAUST MUFFLER

SERVICE INFORMATION	2-1	EXHAUST MUFFLER REMOVAL	2-5
FRAME COVERS	2-2		

SERVICE INFORMATION

GENERAL INSTRUCTIONS

- When removing frame covers, use special care not to pull them by force because the cover joint claws may be damaged.

Items Related for Removal

- Handlebar front cover ——— Handlebar rear cover
Headlight wire connector
- Handlebar rear cover ——— Speedometer cable and instrument light
wire connectors, etc.
- Frame body cover ——— Met-in box, rear grip, rear turn signal
lights, floor board
- Floor board ——— Frame body cover
Battery and wire connectors
- Front tool box ——— Front cover, floor board

TORQUE VALUES

Exhaust muffler joint lock nut	1.0~1.4kgf-m
Exhaust muffler lock bolt	3.0~3.6kgf-m

2. FRAME COVERS/EXHAUST MUFFLER

FRAME COVERS

FRONT COVER REMOVAL

Remove the screw on the front of the front cover.
 Remove the six screws on the back of the front cover.
 Remove the front cover.
 The installation sequence is the reverse of removal.



HANDLEBAR FRONT/REAR COVER REMOVAL

HANDLEBAR FRONT COVER REMOVAL
 Remove the 5 screws attaching the handlebar front cover.
 Disconnect the headlight wire connector and remove the handlebar front cover.

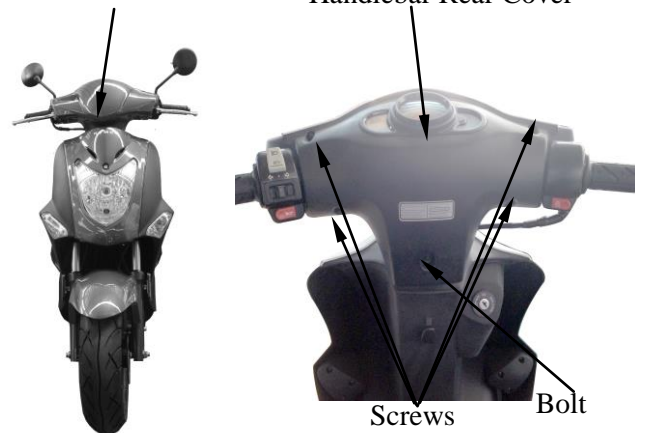

HANDLEBAR REAR COVER REMOVAL

Disconnect the speedometer cable, right and left handlebar switch couplers, and the stop switch wire connectors.
 Remove the bolt attaching the handlebar rear cover.
 Remove two screws inside the handlebar rear cover and remove the handlebar rear cover.
 The installation sequence is the reverse of removal.

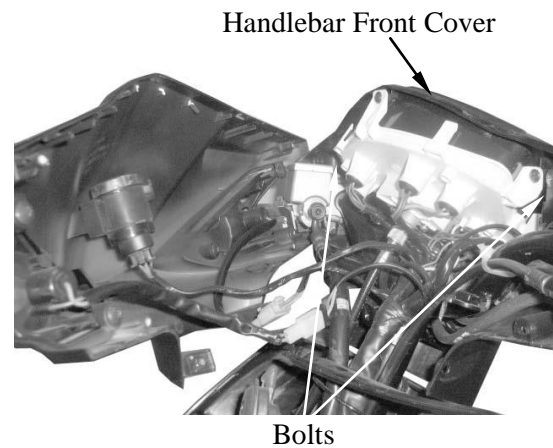

REAR SEAT REMOVAL

(apply to seprative seat model)

Open the seat.

Remove four bolt attaching the rear seat.
 Remove rear seat.

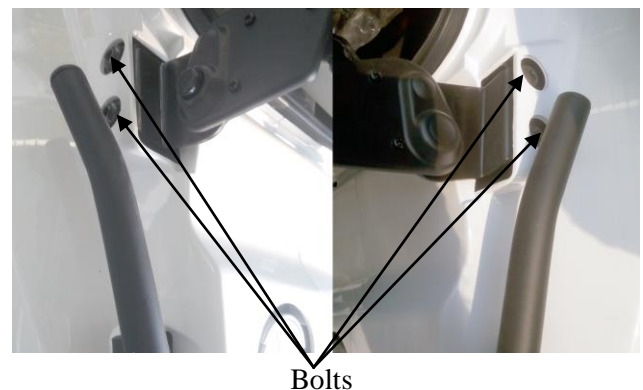

2. FRAME COVERS/EXHAUST MUFFLER

MET-IN BOX REMOVAL

Remove the 5 bolts attaching the met-in box.
Remove the met-in box .

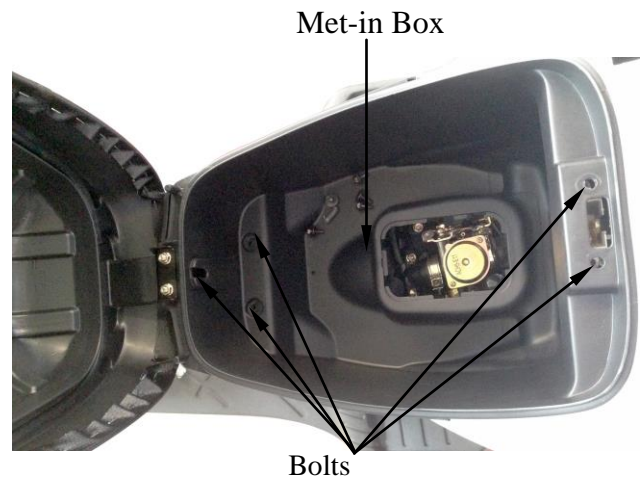

FRAME BODY COVER AND REAR CARRIER REMOVAL

Remove the center cover.
Remove the three bolts attaching the rear carrier.

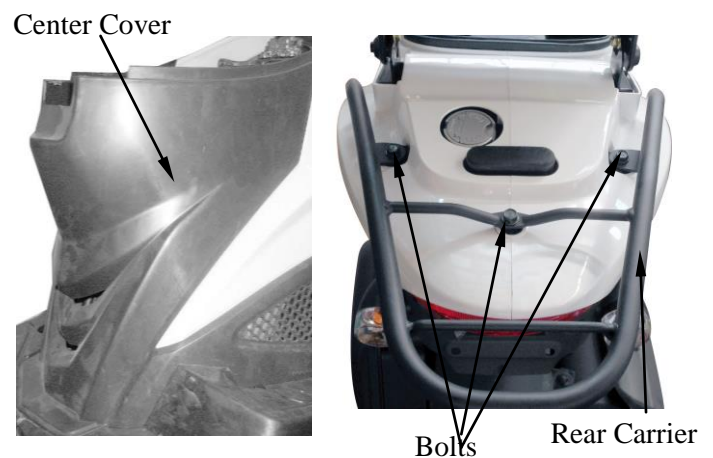

Remove the 4 screws and 2 clips on the rear

part of the frame body cover.
Remove 2 two screws on the front of the frame body cover.

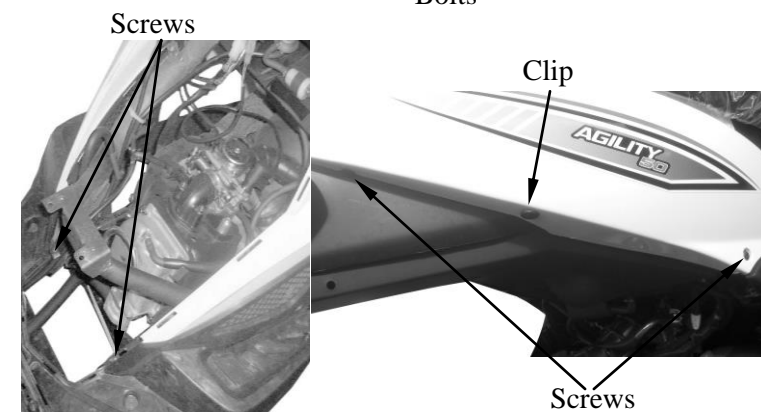

Disconnect the seat lock wire.
Remove the two screws on the frame body cover and frame body cover.

The installation sequence is the reverse of remove

Remove the three bolts attaching each of the right and left side covers.
Remove the right and left side covers.

***** During removal, do not pull the joint claws forcibly to avoid damage.
When installing, be sure to connect the seat lock wire.

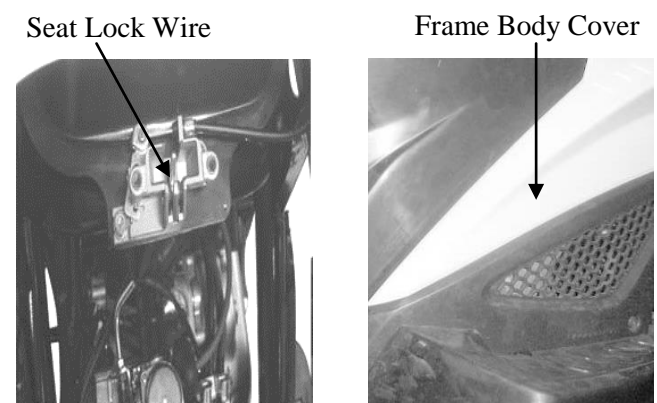

2. FRAME COVERS/EXHAUST MUFFLER

FLOOR BOARD REMOVAL

- Remove the rear carrier and rear seat. (⇒2-3)
- Remove the met-in box. (⇒2-3)
- Remove the frame body cover. (⇒2-4)
- Remove the four bolts and six screws attaching the floor board.
- Remove the floor board.

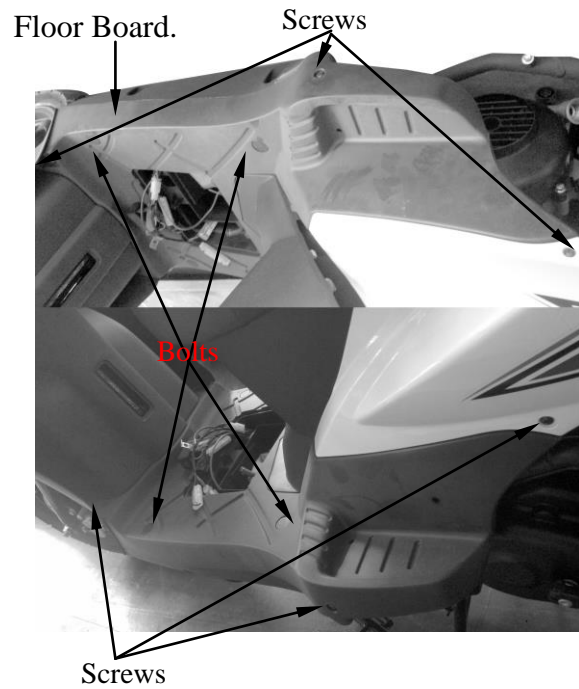

BOTTOM PROTECTOR COVER REMOVAL

- Remove the 4 bolts and 4 screws on the bottom protector cover.
- Remove the bottom protector cover.

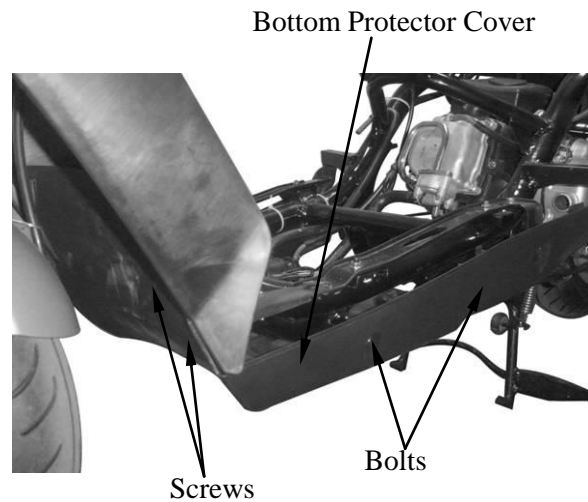

REAR FENDER REMOVAL

- Remove the 2 bolts and 2 clips.
- Remove the rear fender.

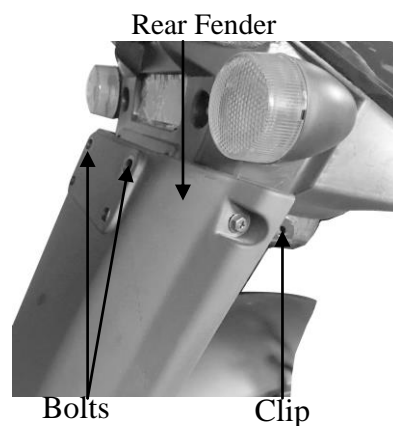

2. FRAME COVERS/EXHAUST MUFFLER

LEG SHIELD REMOVAL

Remove the 1 screw on the leg shield.
Remove the ignition switch decorative ring
Remove the leg shield.



FRONT FENDER REMOVAL

Remove the 4 bolts attaching the front fender bracket.
Remove the front fender.

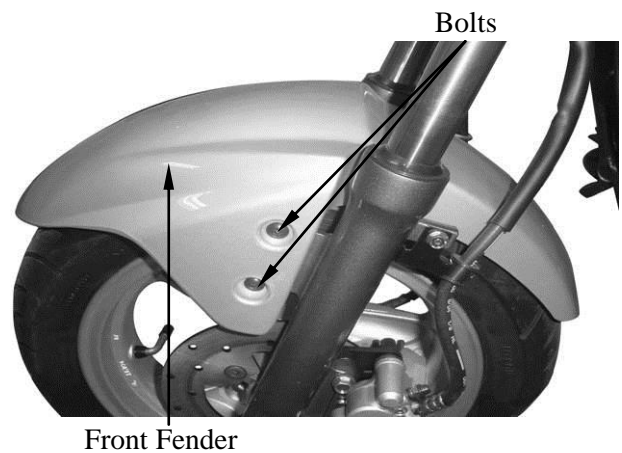

EXHAUST MUFFLER REMOVAL

Remove the two exhaust muffler joint lock nuts.
Remove the two exhaust muffler lock bolts.
Disconnect the O₂ sensor.
Remove the exhaust muffler.
Remove the exhaust muffler joint packing collar.

When installing, first install the exhaust muffler packing collar and then install the exhaust muffler.

First install and tighten the exhaust muffler joint lock nuts. Then, install and tighten the exhaust muffler lock bolts.

Torques:

Exhaust muffler lock bolt: 3.0~3.6kgf-m

Exhaust muffler joint lock nut: 1.0~1.4kgf-m

* Be sure to install a new exhaust muffler packing collar.

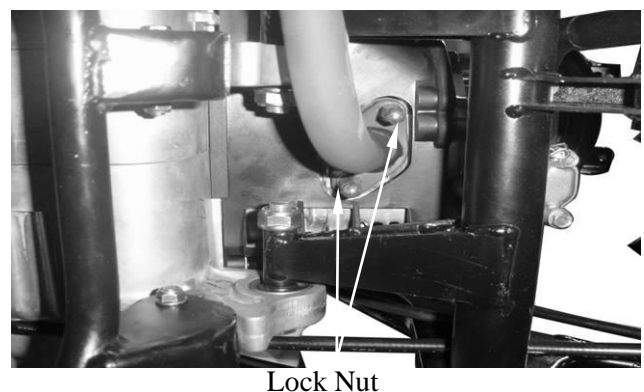
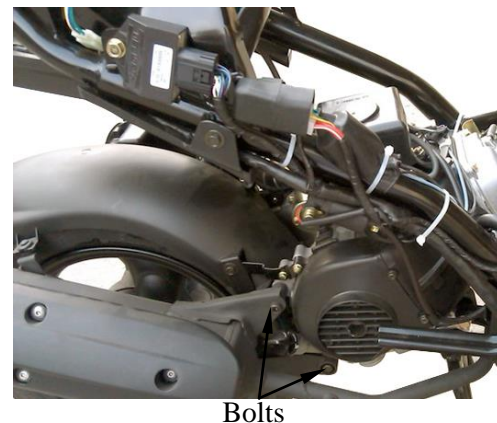

3. INSPECTION/ADJUSTMENT

3

SERVICE INFORMATION.....3-0	FINAL REDUCTION GEAR OIL.....3- 7
MAINTENANCE SCHEDULE3-2	DRIVE BELT.....3- 7
FUEL FILTER.....3-3	BRAKE SHOE.....3- 8
THROTTLE OPERATION3-3	BRAKE ADJUSTING NUT.....3- 8
AIR CLEANER3-4	HEADLIGHT AIM3- 9
SPARK PLUG3-4	CLUTCH SHOE WEAR.....3- 9
VALVE CLEARANCE.....3-5	SUSPENSION3- 9
CARBURETOR IDLE SPEED3-5	NUTS/BOLTS/FASTENERS3-10
IGNITION TIMING3-6	WHEELS/TIRES.....3-10
CYLINDER COMPRESSION.....3-6	STEERING HANDLEBAR.....3-11

SERVICE INFORMATION

GENERAL

WARNING

- Before running the engine, make sure that the working area is well-ventilated. Never run the engine in a closed area. The exhaust contains poisonous carbon monoxide gas which may cause death to people.
- Gasoline is extremely flammable and is explosive under some conditions. The working area must be well-ventilated and do not smoke or allow flames or sparks near the working area or fuel storage area.

SPECIFICATIONS

ENGINE

Throttle grip free play : 2~6mm
 Spark plug gap : 0.7~0.8mm
 Spark plug : NGK CR7HSA/CR6HSA

Valve clearance : IN: 0.08mm
 : EX: 0.08mm

Idle speed : 2000 ±100rpm

Engine oil capacity:

At disassembly : 0.8 liter

At change : 0.7 liter

Gear oil capacity :

At disassembly : 0.18 liter

At change : 0.15 liter

3. INSPECTION/ADJUSTMENT

Cylinder compression : $15 \pm 2 \text{ kg/cm}^2$

Ignition timing: BTDC 12 ° 2000 rpm

CHASSIS

Front brake free play: 10~20mm

Rear brake free play : 10~20mm

TIRE PRESSURE

	1 Rider	2 Riders
Front	1.75kg/cm ²	1.75kg/cm ²
Rear	2.0kg/cm ²	2.25kg/cm ²

TIRE SIZE:

Front : 120/70-12

Rear : 130/70-12

TORQUE VALUES

Front axle nut 5.0~7.0kgf-m

Rear axle nut 11~13kgf-m

3. INSPECTION/ADJUSTMENT

MAINTENANCE SCHEDULE

Perform the periodic maintenance at each scheduled maintenance period.

I: Inspect, and Clean, Adjust, Lubricate or Replace if necessary.

A: Adjust C: Clean R: Replace T: Tighten

Item	Frequency	Whichever comes first ⇄ ↓	Regular Service Mileage (km)											
			1000	2000	3000	4000	5000	6000	7000	8000	9000	10000	11000	12000
Engine oil			R ^{New Motorcycle} 300km	R	R	R	R	R	R	R	R	R	R	R
Engine oil filter screen			C		C				C				C	
Fuel filter screen										R				
Gear oil	Note 3		R ^{New motorcycle} 300km				R					R		
Valve clearance										A				
Carburetor						I				I				C
Air Cleaner	Note 2,3		C	R	C	R	C	R	C	R	C	R	C	R
Spark plug			Clean at every 2000km and replace if necessary											
Brake system			I	I	I	I	I	I	I	I	I	I	I	I
Drive belt									I					
Suspension						I				I				I
Nut, bolt, fastener										I				
Tire						I				I				I
Steering head bearing			I						I					I

- In the interest of safety, we recommend these items should be serviced only by an authorized KYMCO motorcycle dealer.

Note: 1. For higher odometer readings, repeat at the frequency interval established here.

2. Service more frequently when riding in dusty or rainy areas.

3. Service more frequently when riding in rain or at full throttle.

3. INSPECTION/ADJUSTMENT

FUEL FILTER

Remove the met-in box. (⇒2-3)

Check the fuel lines and replace any parts which show signs of deterioration, damage or leakage.

* Do not smoke or allow flames or sparks in your working area.

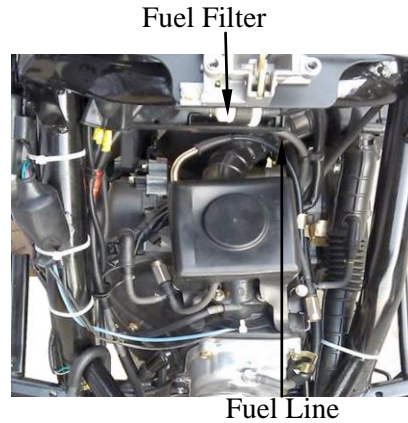

THROTTLE OPERATION

Check the throttle grip for smooth movement. Measure the throttle grip free play.

Free Play: 2~6mm

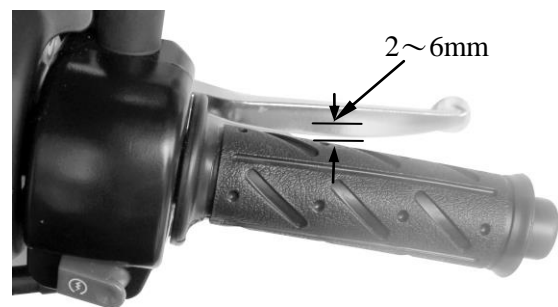

Major adjustment of the throttle grip free play is made at the carburetor side.

Adjust by loosening the lock nut and turning the adjusting nut.

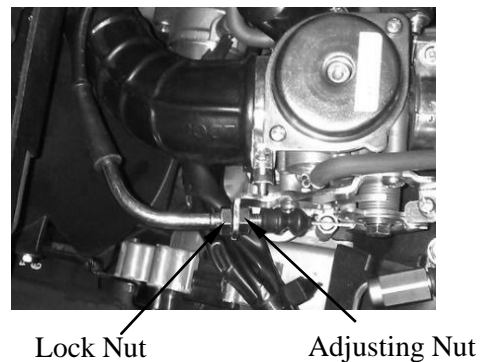

Minor adjustment is made with the adjusting nut at the throttle grip side.

Slide the rubber cover out and adjust by loosening the lock nut and turning the adjusting nut.

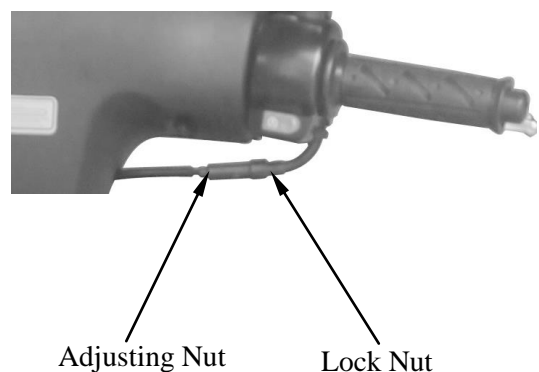

3. INSPECTION/ADJUSTMENT

AIR CLEANER REPLACEMENT

Remove the air cleaner case cover screws and the cover by removing the seven screws.

Remove the air cleaner element by removing the four screws.
Check the element and replace it if it is excessively dirty or damaged.

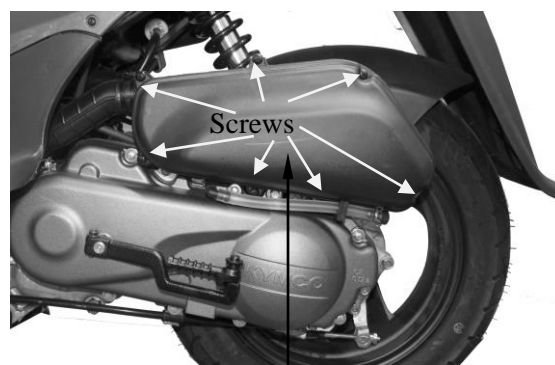

Air Cleaner Case Cover

CHANGE INTERVAL

More frequent replacement is required when riding in unusually dusty or rainy areas.

- * • The air cleaner element has a viscous type paper element. Do not clean it with any fluid.
- Be sure to install the air cleaner element and cover securely.

Air Cleaner Element



SPARK PLUG

Remove the spark plug.
Check the spark plug for wear and fouling deposits.
Clean any fouling deposits with a spark plug cleaner or a wire brush.

Specified Spark Plug:

NGK CR7HSA/CR6HSA



Measure the spark plug gap.

Spark Plug Gap: 0.7~0.8mm

- * When installing, first screw in the spark plug by hand and then tighten it with a spark plug wrench.

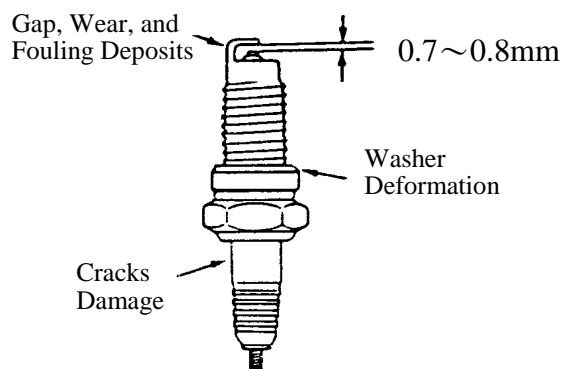

3. INSPECTION/ADJUSTMENT

VALVE CLEARANCE

- * Inspect and adjust valve clearance while the engine is cold (below 35°C).

Remove the frame cover. (⇒2-3)
 Remove the 4 bolts on the cylinder head cover.
 Remove the cylinder head cover. (⇒7-3)
 Remove the cylinder head cover..

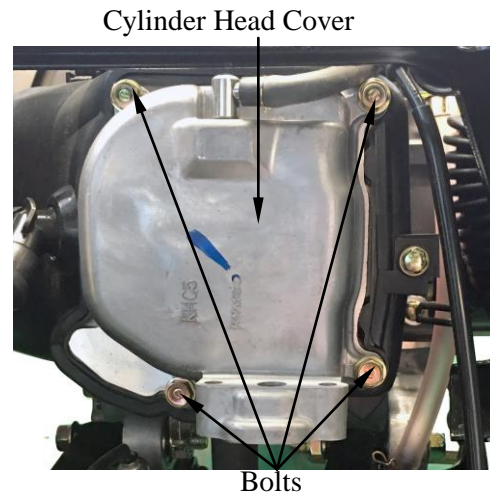

Turn the flywheel counterclockwise so that the “T” mark on the flywheel aligns with the index mark on the crankcase to bring the round hole on the camshaft gear facing up to the top dead center on the compression stroke.

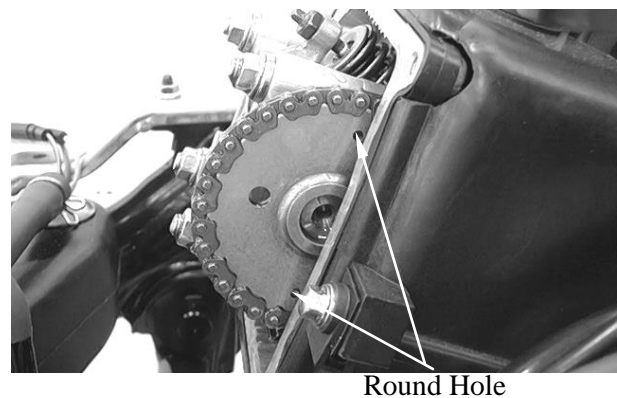

Inspect and adjust the valve clearance.

Valve Clearance: IN : 0.08mm
 EX: 0.08mm

Loosen the lock nut and adjust by turning the adjusting nut

Special

Tappet Adjuster

- * • Check the valve clearance again after the lock nut is tightened.

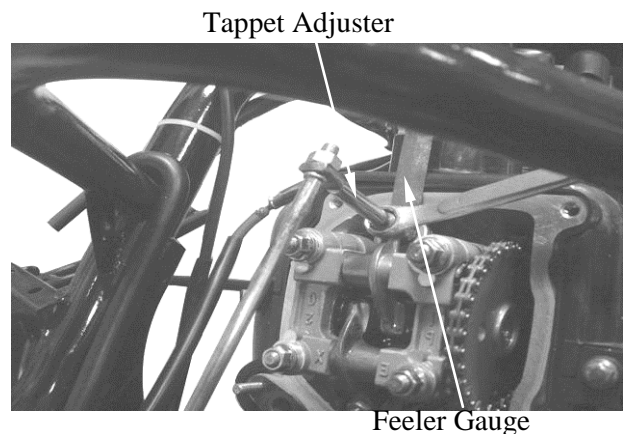

CARBURETOR IDLE SPEED

- * • The engine must be warm for accurate idle speed inspection and adjustment.

Remove the inspection cover.
 Warm up the engine before this operation.
 Start the engine and connect a tachometer.
 Turn the throttle stop screw to obtain the specified idle speed.

Idle Speed: 2000±100rpm

When the engine misses or run erratic, adjust the pilot screw.



3. INSPECTION/ADJUSTMENT

IGNITION TIMING

* The CDI unit is not adjustable. If the ignition timing is incorrect, check the ignition system. (⇒15-5)

Remove the right of the fan cover.

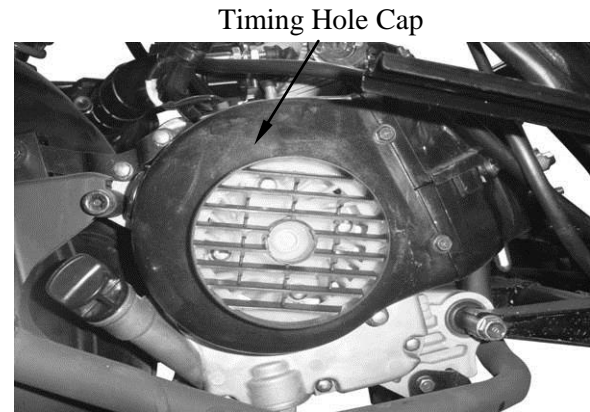

Check the ignition timing with a timing light. When the engine is running at idle speed, the ignition timing is correct if the "F" mark on the flywheel aligns with the index mark on the crankcase.

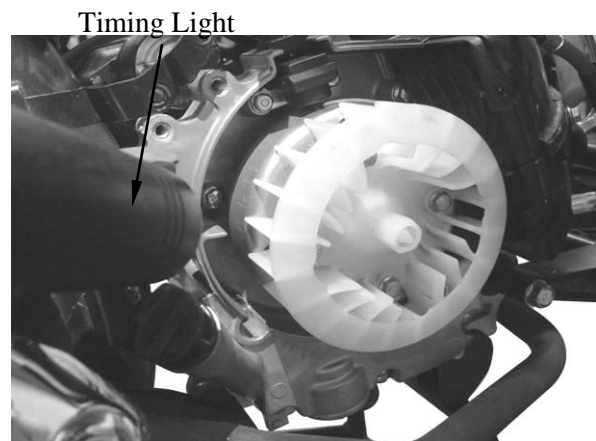

Also use a timing light to check the advance. Raise the engine speed to 4,000rpm and the index mark on the crankcase cover should be aligned with the advance mark on the flywheel.

CYLINDER COMPRESSION

Warm up the engine before compression test. Remove the met-in box and center cover. (⇒2-3)

Remove the spark plug.

Insert a compression gauge.

Open the throttle valve fully and push the starter button to test the compression.

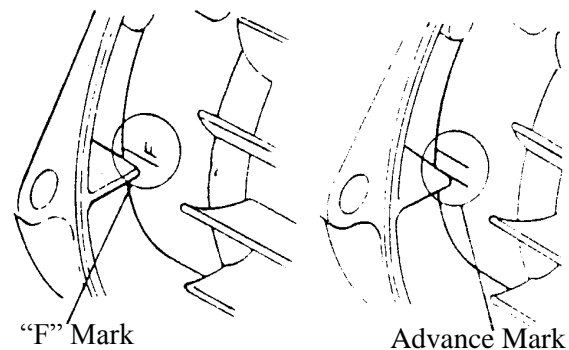

Compression: 15 ± 2 kg/cm²rpm

If the compression is low, check for the following:

- Leaky valves
- Valve clearance too small
- Leaking cylinder head gasket
- Worn piston rings
- Worn piston/cylinder

If the compression is high, it indicates that carbon deposits have accumulated on the combustion chamber and the piston head.

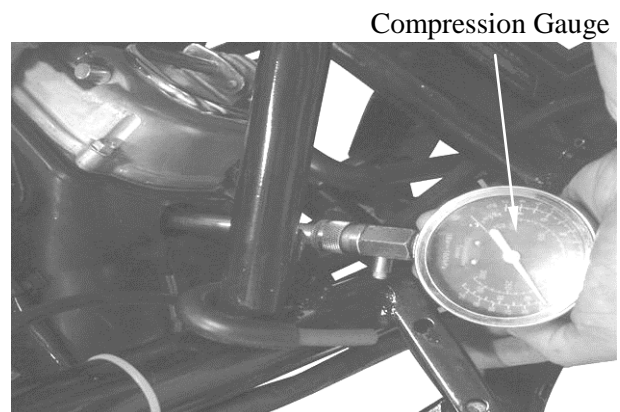

3. INSPECTION/ADJUSTMENT

FINAL REDUCTION GEAR OIL OIL LEVEL CHECK

- * Place the motorcycle on its main stand on level ground for oil level check.

Stop the engine and remove the oil check bolt. The oil level shall be at the oil check bolt hole.

If the oil level is low, add the recommended oil to the proper level.

Recommended Oil: SAE90#



Oil Check Bolt/Sealing Washer

Install the oil check bolt.

- * Make sure that the sealing washer is in good condition.

OIL CHANGE

Remove the oil check bolt.

Remove the oil drain bolt and drain the oil thoroughly.

Install the oil drain bolt.

Torque: 0.8~1.2kgf-m

- * Make sure that the sealing washer is in good condition.



Oil Drain Bolt/ Sealing Washer

Fill with the recommended oil.

Oil Capacity: At disassembly : 0.18 liter
At change : 0.15 liter

Reinstall the oil check bolt and check for oil leaks.

Torque: 0.8~1.2kgf-m

DRIVE BELT

Remove the left crankcase cover. (⇒9-2)

Inspect the drive belt for cracks or excessive wear.

Replace the drive belt with a new one if necessary and in accordance with the Maintenance Schedule.

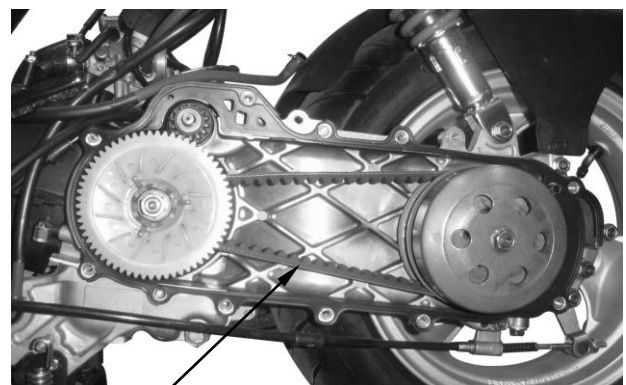

Drive Belt

3. INSPECTION/ADJUSTMENT

BRAKE SHOE

Replace the brake shoes if the arrow on the wear indicator plate aligns with the punch mark on the brake panel when the brake is fully applied.

Refer to page 12-7 and 13-3 for brake shoe replacement.

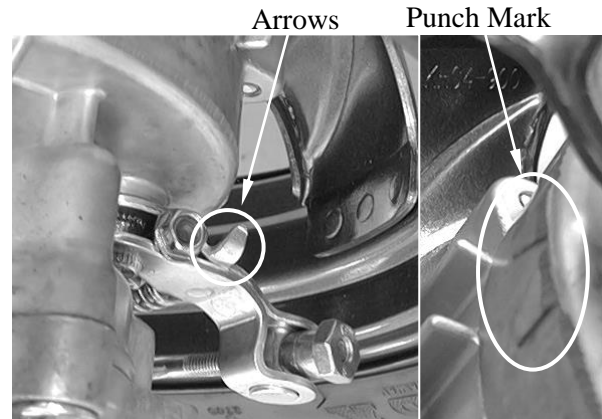

REAR BRAKE

Measure the rear brake lever free play.

Free Play: 10~20mm



BRAKE ADJUSTING NUT

If the free play do not fall within the limit, adjust by turning the adjusting nut.



Adjusting Nut

BRAKE FLUID

Turn the steering handlebar upright and check if the rear brake fluid level should be between the upper and lower level lines.

Specified Brake Fluid: DOT-4 ◦

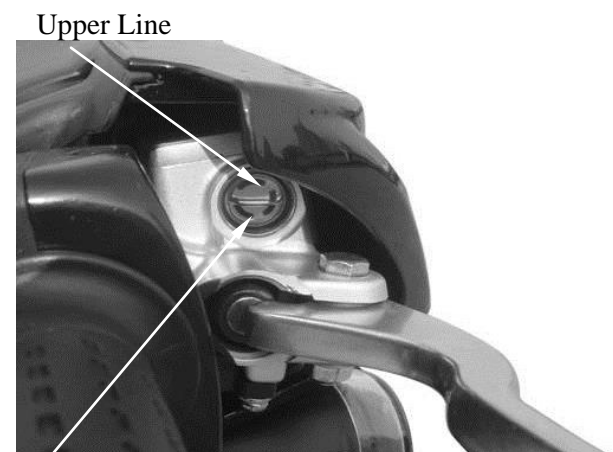

Lower Line

3. INSPECTION/ADJUSTMENT

If the free play do not fall within the limit, adjust by turning the adjusting nut.

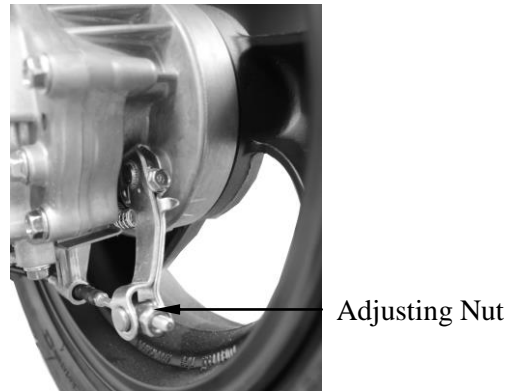

HEADLIGHT AIM

Turn the ignition switch ON and start the engine.
Turn on the headlight switch.
Adjust the headlight aim by turning the headlight aim adjusting screw.

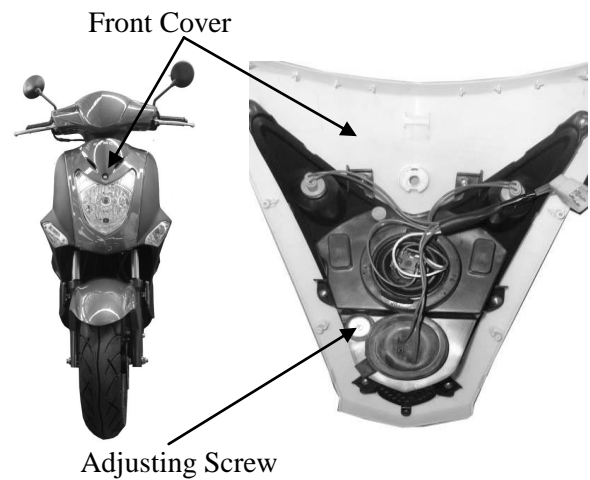

CLUTCH SHOE WEAR

Start the engine and check the clutch operation by increasing the engine speed gradually.
If the motorcycle tends to creep, or the engine stalls, check the clutch shoes for wear and replace if necessary. (⇒9-11)

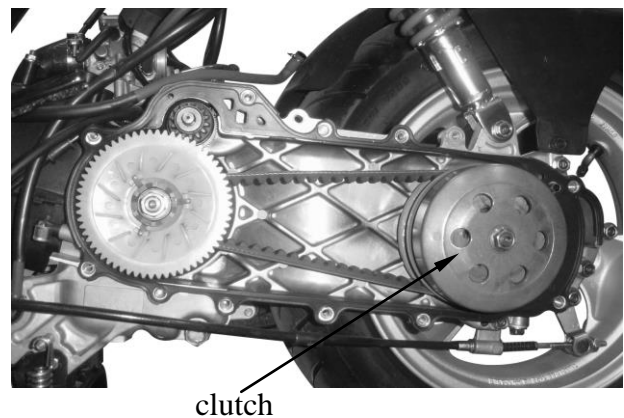

SUSPENSION

FRONT

Fully apply the front brake lever and check the action of the front shock absorbers by compressing them several times.
Check the entire shock absorber assembly for oil leaks, looseness or damage.



3. INSPECTION/ADJUSTMENT

REAR

Check the action of the rear shock absorber by compressing it several times.
 Check the entire shock absorber assembly for oil leaks, looseness or damage.
 Jack the rear wheel off the ground and move the rear wheel sideways with force to see if the engine hanger bushings are worn.



NUTS/BOLTS/FASTENERS

Check all important chassis nuts and bolts for looseness.
 Tighten them to their specified torque values if any looseness is found. (⇒1-11)

WHEELS/TIRES

Check the tires for cuts, imbedded nails or other damages.

Check the tire pressure.

* Tire pressure should be checked when tires are cold.



TIRE PRESSURE

	1 Rider	2 Riders
Front	1.75kg/cm ²	1.75kg/cm ²
Rear	2.00kg/cm ²	2.25kg/cm ²

TIRE SIZE

Front : 120/70-12

Rear : 130/70-12

Check the front axle nut for looseness.
 Check the rear axle nut for looseness.
 If the axle nuts are loose, tighten them to the specified torques.

Torques: Front : 5.0~7.0kgf-m

Rear : 11~13kgf-m



Front Axle Nut

3. INSPECTION/ADJUSTMENT

STEERING HANDLEBAR

Check that the control cables do not interfere with handlebar rotation.

Raise the front wheel off the ground and check that the steering handlebar rotates freely.

If the handlebar moves unevenly, binds, or has vertical movement, adjust the steering head bearing.

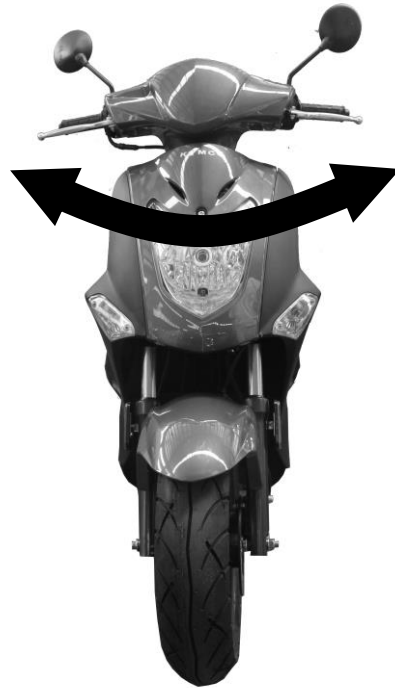

4. LUBRICATION SYSTEM

LUBRICATION SYSTEM

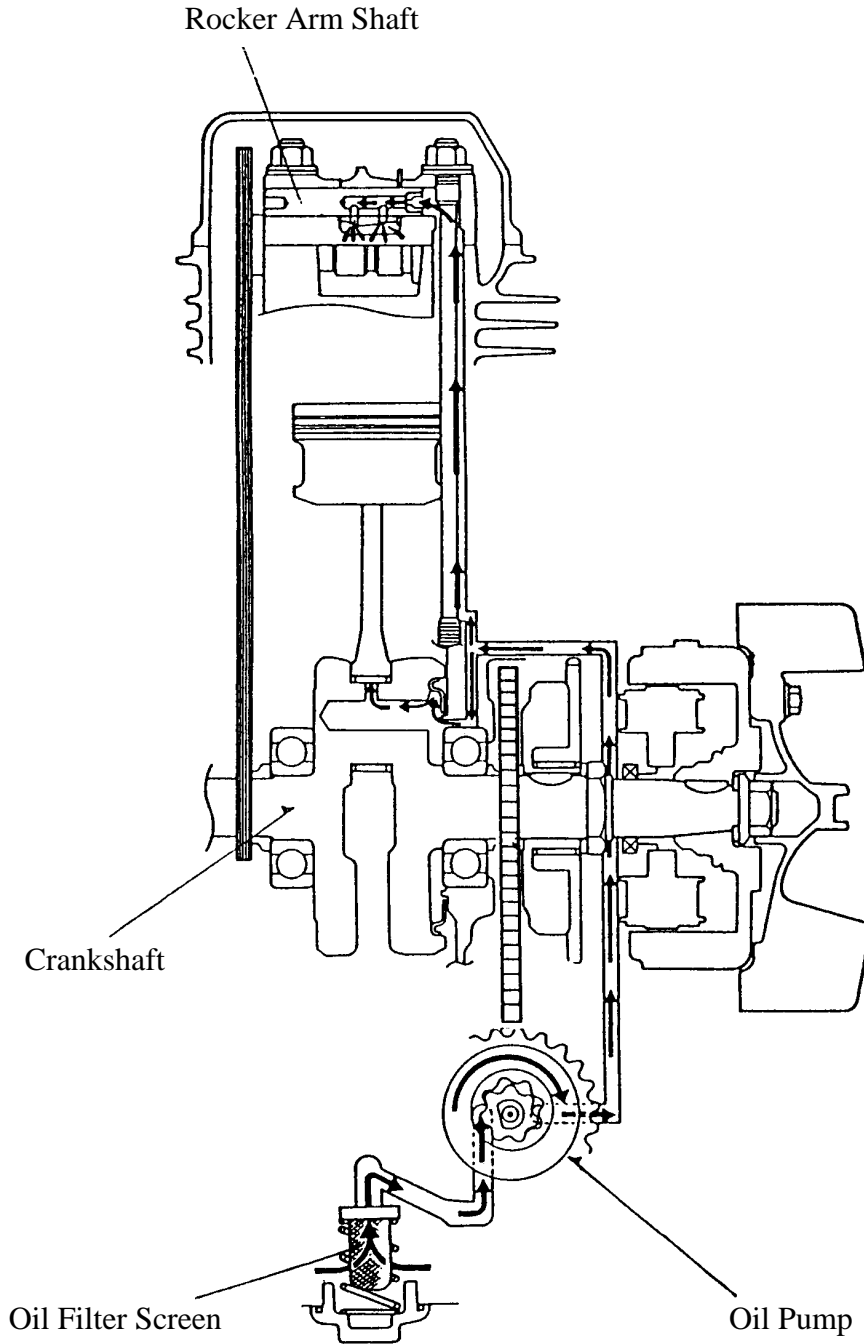

4

4. LUBRICATION SYSTEM

SERVICE INFORMATION.....4-1	ENGINE OIL/OIL FILTER..... 4-2
TROUBLESHOOTING4-1	OIL PUMP..... 4-3

SERVICE INFORMATION

GENERAL INSTRUCTIONS

- The maintenance of lubrication system can be performed with the engine installed in the frame.
- Use care when removing and installing the oil pump not to allow dust and foreign matters to enter the engine and oil line.
- Do not attempt to disassemble the oil pump. The oil pump must be replaced as a set when it reaches its service limit.
- After the oil pump is installed, check each part for oil leaks.

SPECIFICATIONS

Item		Standard (mm)	Service Limit (mm)
Oil pump	Inner rotor-to-outer rotor clearance	—	0.12
	Outer rotor-to-pump body clearance	—	0.12
	Rotor end-to-pump body clearance	0.05~0.10	0.2

TROUBLESHOOTING

Oil level too low

- Natural oil consumption
- Oil leaks
- Worn or poorly installed piston rings
- Worn valve guide or seal

Poor lubrication pressure

- Oil level too low
- Clogged oil filter or oil passages
- Not use the specified oil

4. LUBRICATION SYSTEM

ENGINE OIL/OIL FILTER

OIL LEVEL

- * Place the motorcycle upright on level ground for engine oil level check.
- Run the engine for 2~3 minutes and check the oil level after the engine is stopped for 2~3 minutes.

Remove the oil dipstick and check the oil level with the oil dipstick.
If the level is near the lower level, fill to the upper level with the specified engine oil.

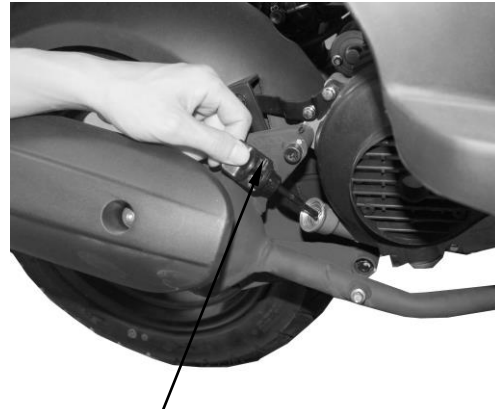

Oil Dipstick

OIL CHANGE

- * The engine oil will drain more easily while the engine is warm.

Remove the drain bolt to drain the engine oil thoroughly.
Remove the oil filter screen cap and clean the oil filter screen with compressed air.



Oil Filter Screen Cap

Check the filter screen O-ring for damage and replace if necessary.
Install the oil filter screen, spring and filter screen cap.
Torque: 1.0~2.0kgf-m

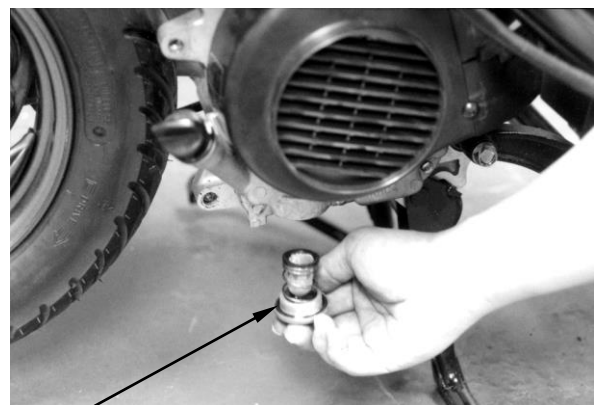

O-ring

Fill the crankcase with the specified engine oil to the proper level.

Oil Capacity: At disassembly : 0.8 liter
 At change : 0.7 liter

Check for oil leaks and then start the engine and let it idle for few minutes.
Recheck the oil level.

4. LUBRICATION SYSTEM

OIL PUMP

REMOVAL

Remove the A.C. generator flywheel. (⇒14-7)

Remove the A.C. generator stator and pulsar coil. (⇒14-6)

Remove the eight right crankcase cover bolts and the right crankcase cover.

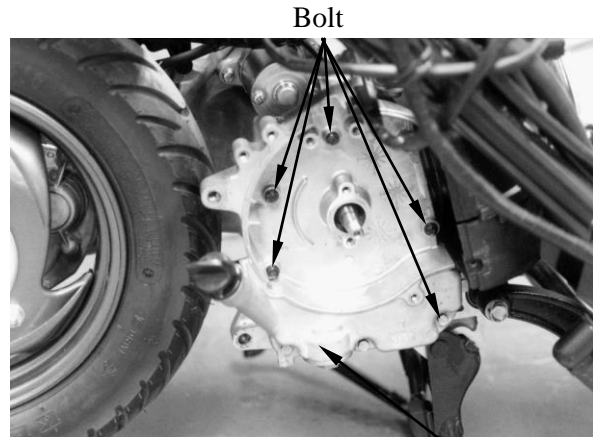

Right Crankcase Cover

Remove the gasket and dowel pins.

Remove the oil pump drive gear circlip.

Remove the oil pump gear.

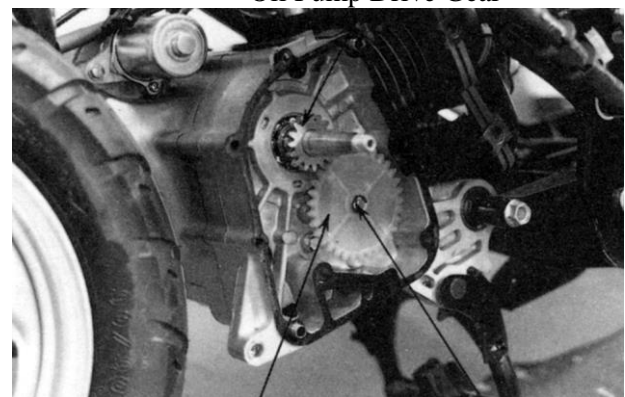

Oil Pump Gear

Circlip

Remove the oil pump mounting bolts.

Remove the oil pump.

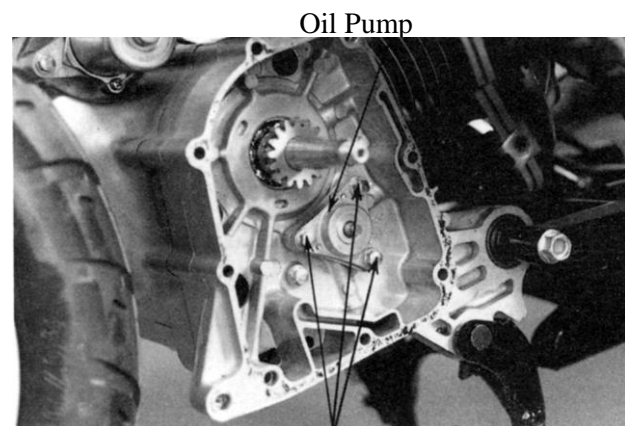

Bolts

Remove the two O-rings.

Inspect the two O-rings for damage or deterioration.

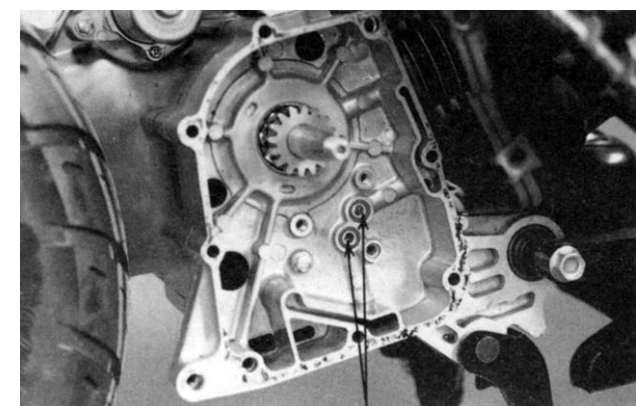

O-rings

4. LUBRICATION SYSTEM

DISASSEMBLY

Remove the three oil pump boby screws.
Disassembly the oil pump.

Oil Pump Bobby

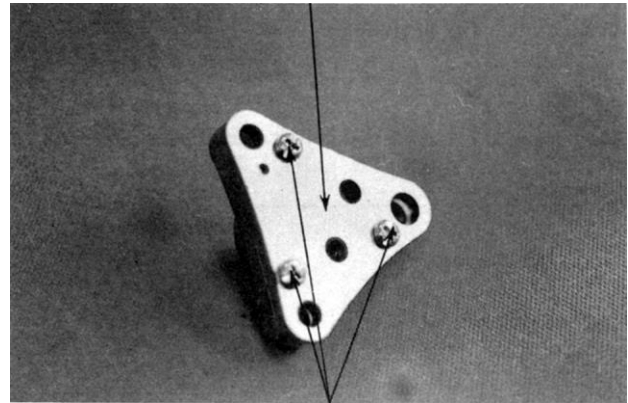

Screws

INSPECTION

Measure the pump boby-to-outer rotor clearance.

Service Limit: 0.12mm

Outer Rotor

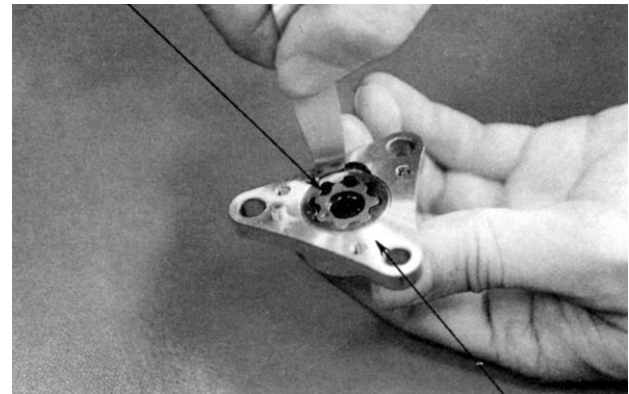

Oil Pump Bobby

Measure the inner rotor-to-outer rotor clearance.

Service Limit: 0.12mm

Outer Rotor

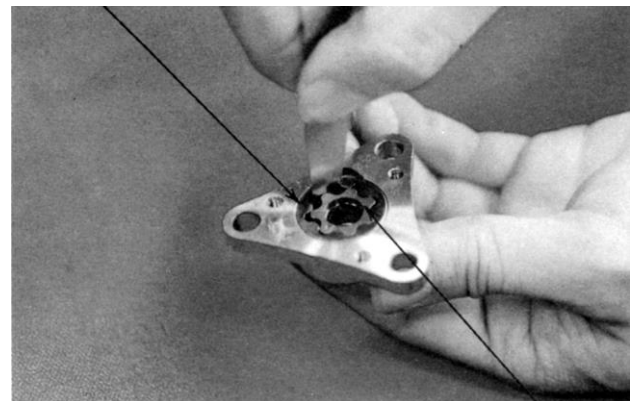

Inner Rotor

Measure the rotor end-to- pump boby clearance.

Service Limit: 0.2mm

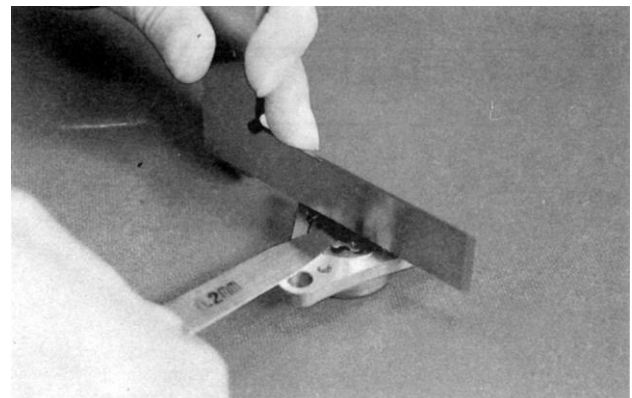

4. LUBRICATION SYSTEM

ASSEMBLY

Install the outer rotor, inner rotor and pump shaft into the pump body.

- * Install the pump shaft by aligning the flat on the shaft with the flat in the inner rotor.

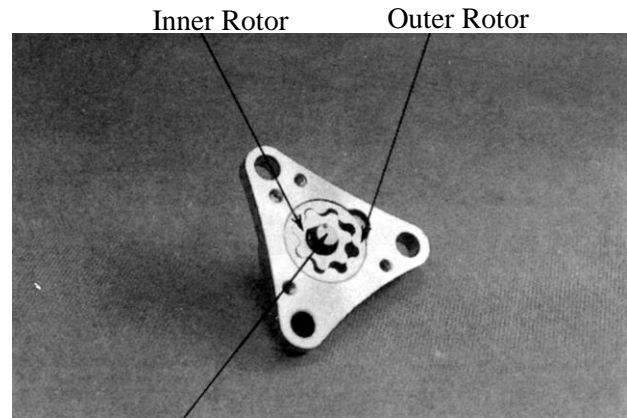

Pump Shaft

Install the pump cover and tighten the screws to secure the pump cover.

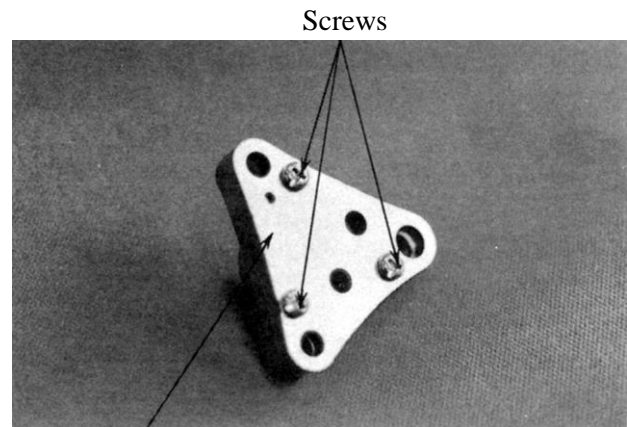

Pump Cover

INSTALLATION

First install the two O-rings onto the oil pump base.

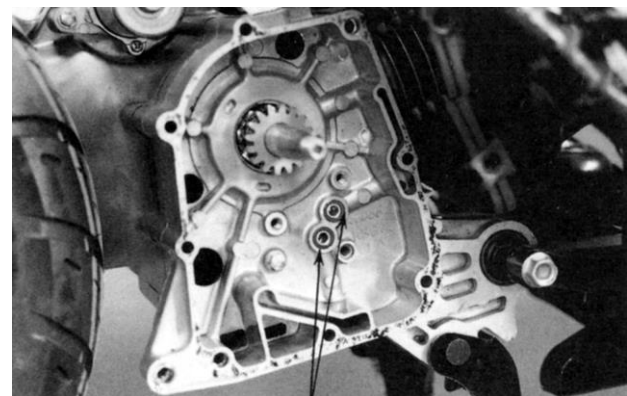

O-rings

Install the oil pump into the crankcase.

- * Fill the oil pump with engine oil before installation.

After the oil pump is installed, tighten the three mounting bolts.

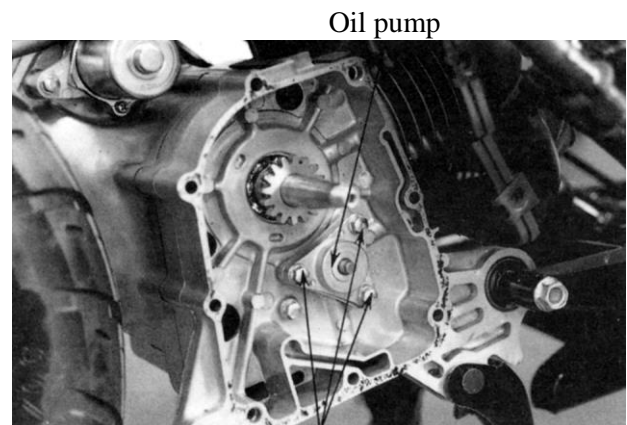

Bolts

4. LUBRICATION SYSTEM

Install the pump driven gear and secure it with the circlip.

Torque: 0.8~1.2kg-m

Pump Driven Gear



Circlip

Install the right crankcase cover and tighten the eight bolts.

Torque: 0.8~1.2kgf-m

* Diagonally tighten the bolts in 2~3 times.

Right Crankcase Cover

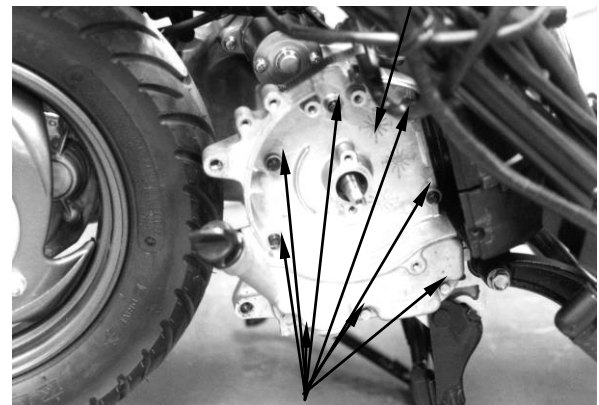

Bolts

5. FUEL SYSTEM

MECHANISM ILLUSTRATION	4-1	AUTO BY-STARTER	4-7
PRECAUTIONS IN OPERATION	4-2	FLOAT CHAMBER	4-8
TROUBLE DIAGNOSIS	4-3	INSTALLATION OF CARBURETOR ..	4-9
CARBURETOR REMOVAL	4-4	IDLE SPEED ADJUSTMENT	4-9
VACUUM CHAMBER	4-4	FUEL TANK	4-10
ACCELERATE PUMP	4-6	AIR CLEANER	4-11

MECHANISM ILLUSTRATION

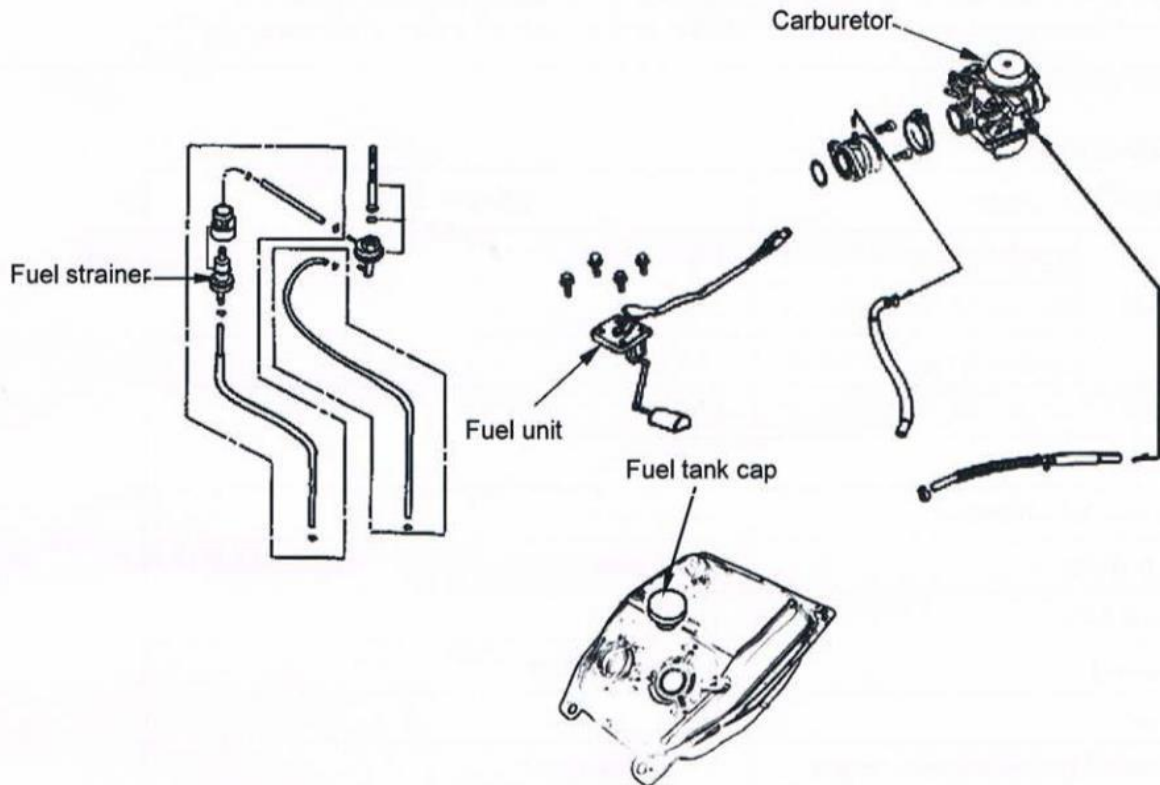

PRECAUTIONS IN OPERATION

General Information

Warning

Gasoline is a low ignition point and explosive materials, so always work in a well-ventilated place and strictly prohibit flame when working with gasoline.

Cautions

- Do not bend or twist throttle valve cable. Damaged cable will make unstable driveability.
- When disassembling fuel system parts, pay attention to O-ring position, replace with new one as re-assembly
- There is a drain screw in the float chamber for draining residual gasoline.
- Do not disassemble automatic by-starter and air cut-off valve arbitrarily.

Specification

Item	Specification
Main jet	84#
Needle jet	φ2.6#
Level in float chamber	10mm±1mm
Float needle	φ4.2±0.1mm
Mass of float	7.9g±0.2g
Idle speed	2000±100rpm
Slow jet	35#
Fuel quantity adjustment screw	2 1/4±0.5turns
Throttle handle free play	2-6mm

Torque value

Fuel valve tightening nut: 1.5~2.0 Kgf-m

Tool

Special service tools

Vacuum/air pressure pump

General service tools

Fuel level gauge

5. FUEL SYSTEM

TROUBLE DIAGNOSIS

Poor engine start

- No fuel in fuel tank
- Clogged fuel tube
- Too much fuel in cylinder
- No spark from spark plug (malfunction of ignition system)
- Clogged air cleaner
- Malfunction of automatic by-starter
- Malfunction of throttle valve operation

Stall after started

- Malfunction of automatic by-starter
- Incorrect ignition timing
- Malfunction of carburetor
- Dirty engine oil
- Air existing in intake system
- Incorrect idle speed

Rough idle

- Malfunction of ignition system
- Incorrect idle speed
- Malfunction of carburetor
- Dirty fuel

Intermittently misfire as acceleration

- Malfunction of ignition system

Late ignition timing

- Malfunction of ignition system
- Malfunction of carburetor

Power insufficiency and fuel consuming

- Fuel system clogged
- Malfunction of ignition system

Mixture too lean

- Clogged fuel injector
- Vacuum piston stick and closed
- Malfunction of float valve
- Fuel level too low in float chamber
- Clogged fuel tank cap vent
- Clogged fuel filter
- Obstructed fuel pipe
- Clogged air vent hose
- Air existing in intake system

Mixture too rich

- Clogged air injector
- Malfunction of float valve
- Fuel level too high in float chamber
- Malfunction of automatic by-starter
- Dirty air cleaner

5. FUEL SYSTEM

CARBURETOR REMOVAL

Remove the luggage box.
 Loosen the adjustment nut and fixing nut of throttle valve cable, and release the cable from carburetor.
 Remove fuel pipe, vacuum hose.
 Disconnect auto by-starter connector.
 Disconnect gulp valve connectors.
 Disconnect TPS controller connector.
 Release the clamp strip of air cleaner.
 Release the clamp strip of carburetor isolator.
 Take the carburetor out.

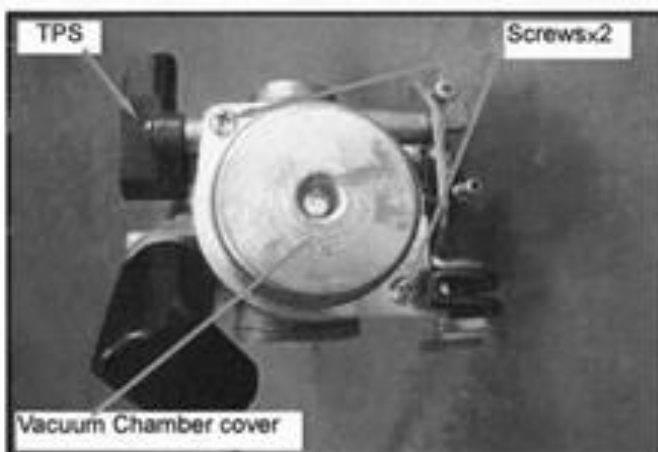
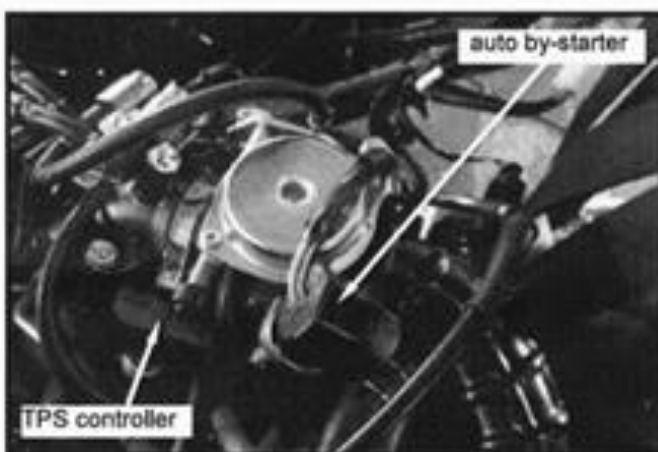
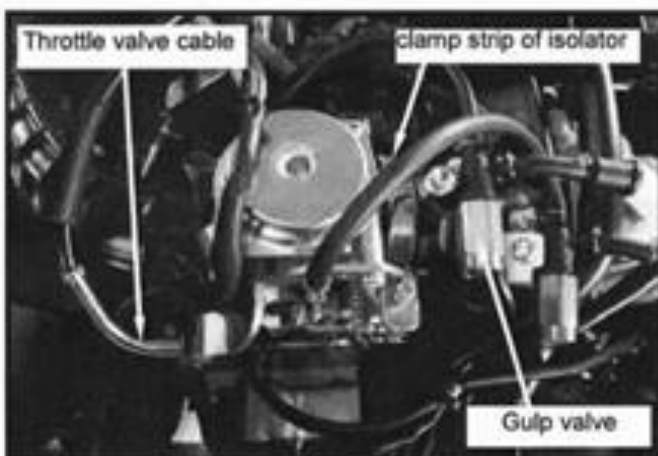

VACUUM CHAMBER

Removal

Loosen drain screw, and drain out residual fuel in float chamber.
 Remove screws (2 screws) of vacuum chamber cover and the cover.

Remove compress spring and vacuum piston.

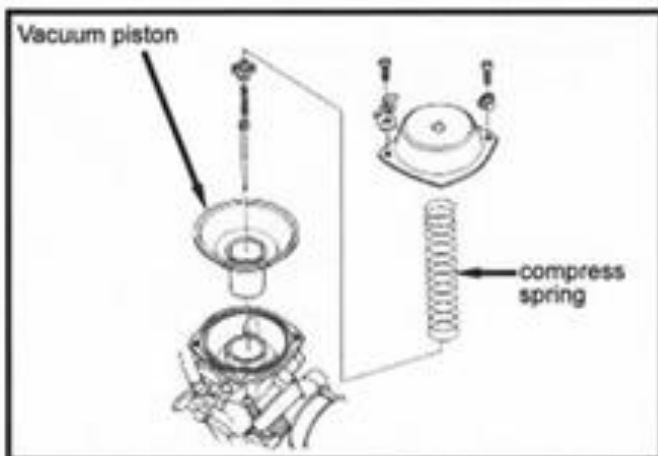

5. FUEL SYSTEM

Remove fuel needle seat, spring, and injector needle.
 Check if the vacuum piston for wear out, crack or other damage.
 Check if the diaphragm for damage or crack.

Cautions

Do not damage vacuum diaphragm.

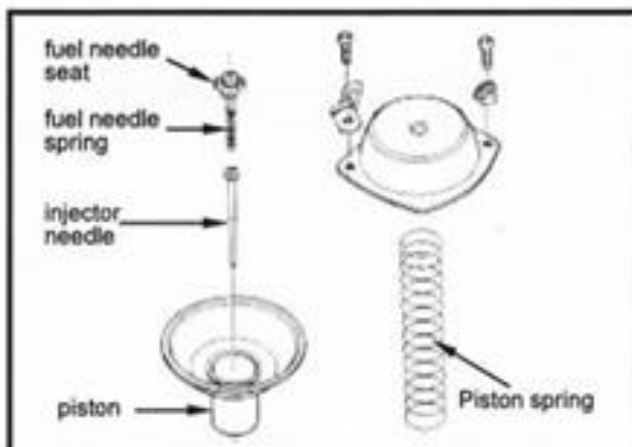

Installation

Install injector needle, spring and fuel needle seat to vacuum piston.

Cautions

- Note direction as installing the piston set because wrong direction of the piston can not be installed.
- Align the indent of vacuum diaphragm with the carburetor body.

Install vacuum piston to carburetor body.
 Install compress spring.

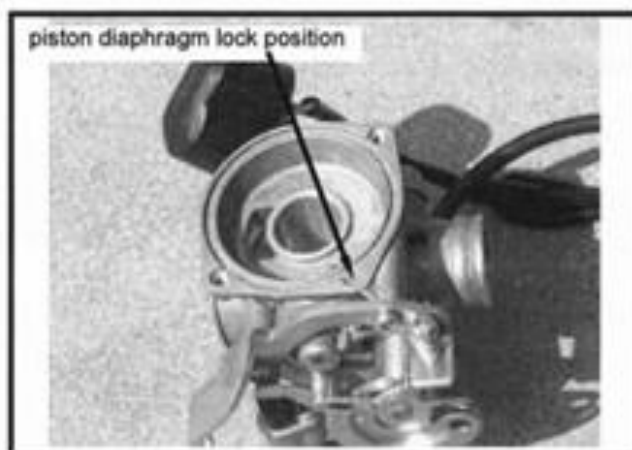

Install vacuum chamber cover and tighten 2 screws.

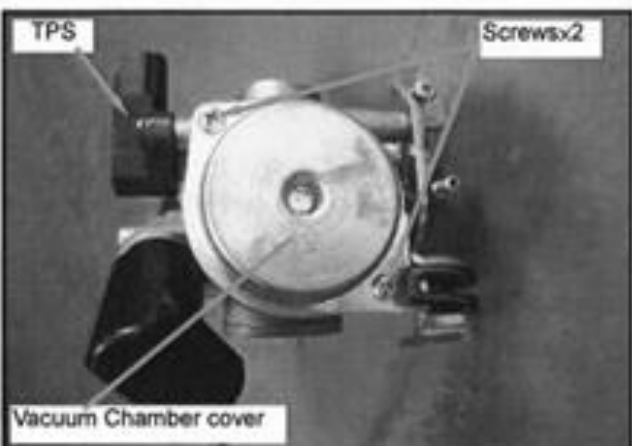

5. FUEL SYSTEM

ACCELERATE PUMP

Removal

Loosen the fixing screws from carburetor.



Remove the accelerate pump drive arm from the carburetor.

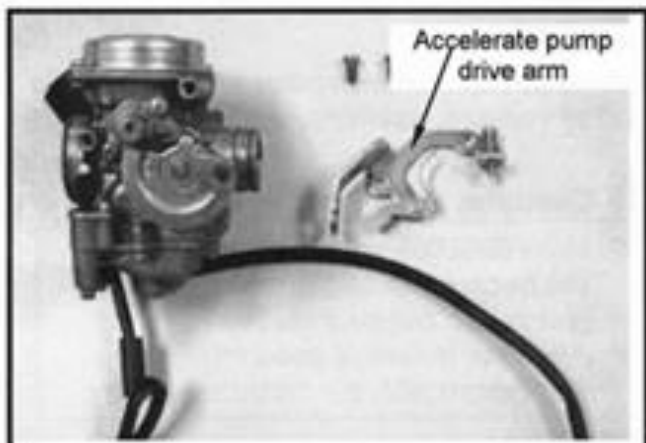

Remove 3 mounting screws and remove the float chamber cover.

Remove 3 mounting screws and remove the float chamber cover.

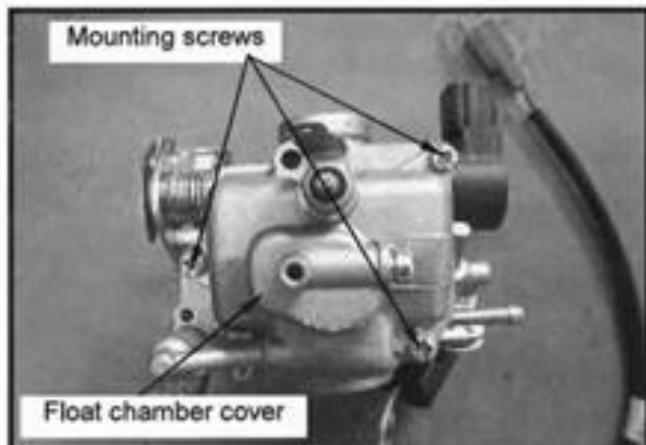

Installation

Install the valve as reverse order of removal.

⚠ Cautions

Do not damage the vacuum diaphragm or in opposite installation direction.

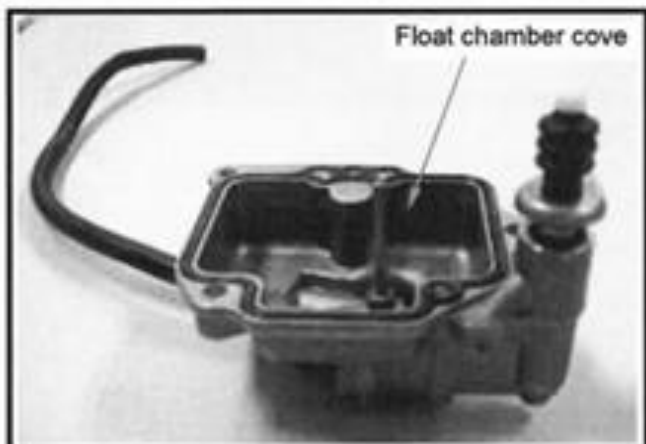

5. FUEL SYSTEM

AUTO BY-STARTER

Inspection

Turn off engine and waiting for over 10 minutes for cooling.

Check resistance across the two terminals of the auto by-starter

Resistance value: Max. 10Ω (Measured after engine stopped for more than 10 minutes)

Replace the auto by-starter with a new one if resistance value exceeds standard.

Remove the carburetor, allow it to cool off for 30 minutes.

Connect a hose to fuel richment circuit.

Pump compressed air to the circuit.

Replace the auto by-starter if the circuit clogged.

Connect battery posts (12V) to starter's connectors. After 5 minutes, test the rich circuit with compressed air. If air flow through the circuit, then replace the starter.

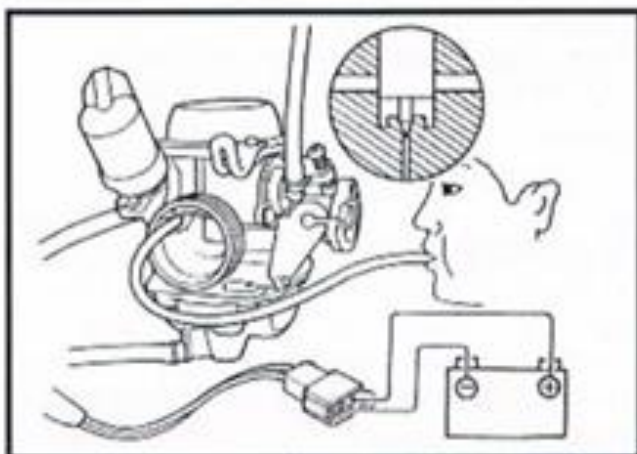
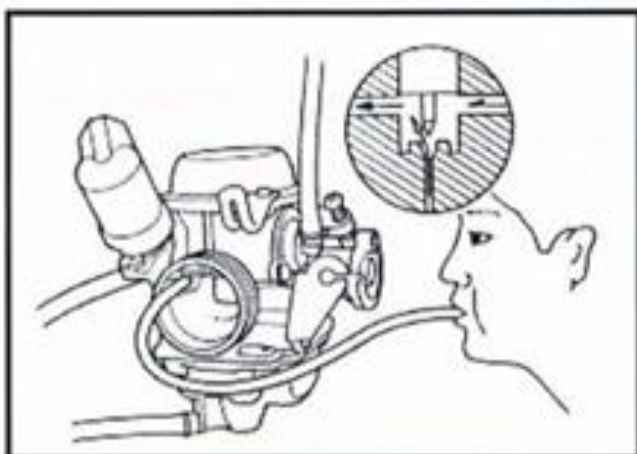

Removal

Remove fixing plate screw, and then remove the plate and auto by-starter from carburetor.

Valve inspection

Check if auto by-starter and valve needle for damage or wear out.

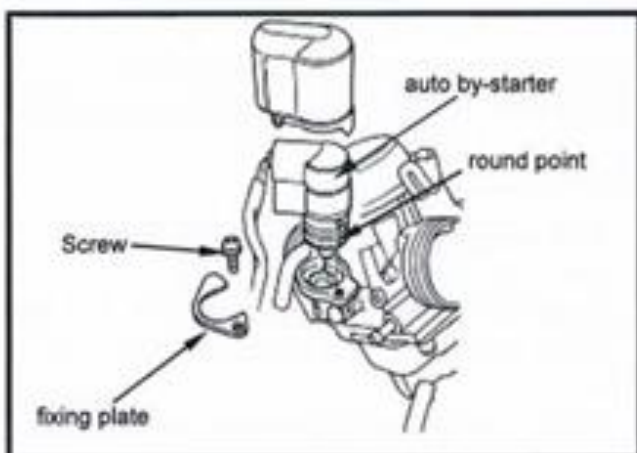

Installation

Install auto by-starter to the carburetor body. Install fixing plate to the upper groove of auto by-starter, and install its flat surface to carburetor. Install screw and tighten it.

⚠ Cautions

Align the round point of the starter with the screw hole of air intake side.

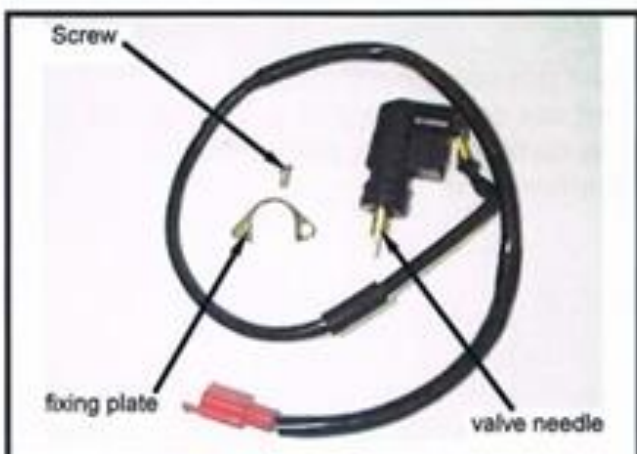

5. FUEL SYSTEM

FLOAT CHAMBER

Disassembly

Remove 3 mounting screws and remove the float chamber cover.

Remove the float pin and float valve.

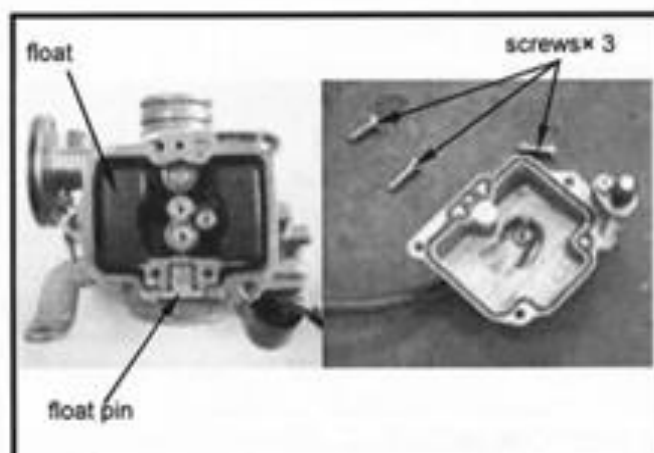

Checking

Check float needle valve and valve seat for drop difference damage, wear out, dirty or clogged.

Cautions

In case of worn out or dirt, the float needle valve and valve seat will not tightly close causing fuel level to increase and as a result, fuel flooding. A worn out or dirty float needle valve must be replaced with a new one.

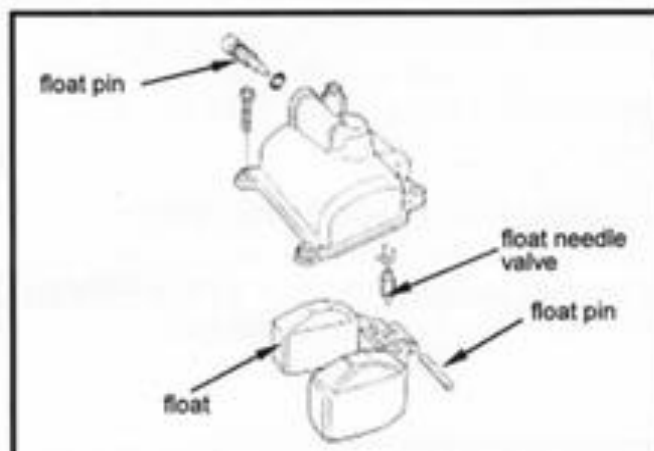

Remove main jet, slow jet, fuel amount adjustment screw.

Cautions

- Take care not to damage jets and adjust screw.
- Before removing adjustment screw, turn it all the way down and note the number of turns.
- Do not turn adjustment screw forcefully to avoid damaging valve seat face.

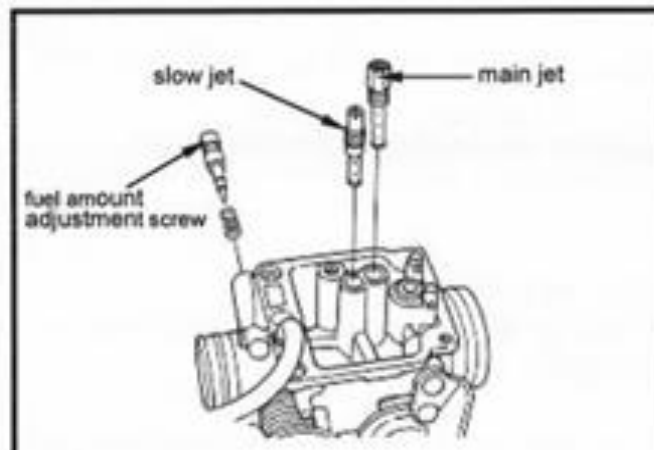

Clean jets with cleaning fluid.
Then use compressed air to blow dirt off.
Blow carburetor body passages with compressed air.

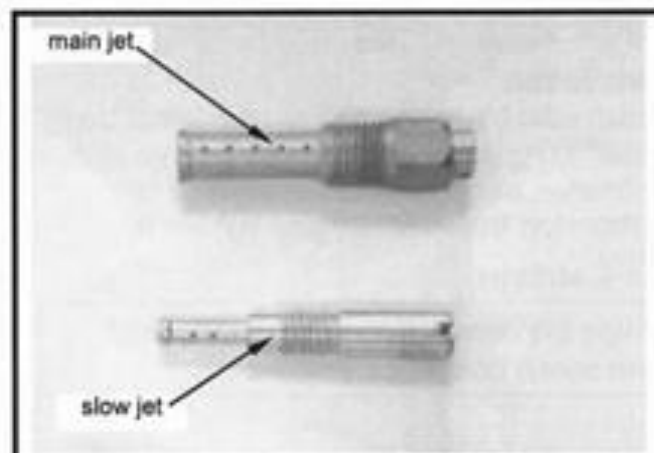

5. FUEL SYSTEM

Installation

Install main jet, slow jet and fuel amount adjustment screw.

Cautions

Set the adjustment screw in according to number of turns noted before it was removed.

Install the float needle valve, float and float pin.

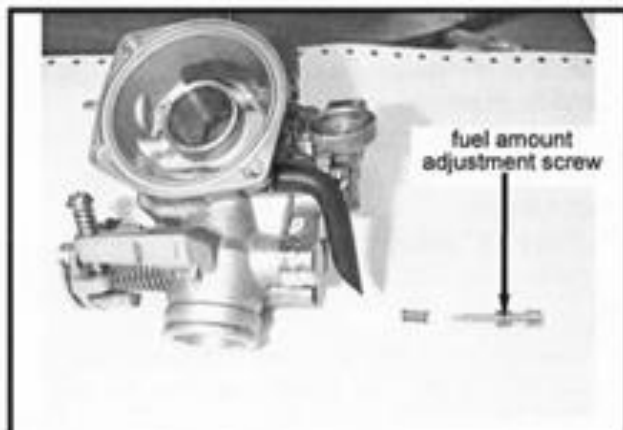

Checking Fuel Level

Cautions

- Check again to ensure float valve, float for proper installation.
- To ensure correct measurement, position the float meter in such a way so that float chamber face is vertical to the main jet.

Fuel level: 3.5 ± 1 mm

INSTALLATION OF CARBURETOR

Install carburetor in the reverse order of removal. Following adjustments must be made after installation.

- Throttle valve cable clearance adjustment
- Idle speed adjustment

IDLE SPEED ADJUSTMENT

Caution

- Fuel amount adjust screw was set at factory, so no adjustment is needed. Note the number of turns it takes to screw it all the way in for ease of installation.
- Never screw in forcedly to avoid damaging the screw seat.
- The main stand must be used to support the motorcycle to perform the adjustments.

Use a tachometer when adjusting engine RPM. Screw in adjustment screw gently, then back up to standard turns.

Standard turns: $2 \frac{1}{4} \pm 0.5$ turns

Warm up engine, adjust throttle valve stopper screw to standard RPM

Idle speed rpm: 2000 ± 100 rpm

Connect the sampling hose of exhaust analyzer to exhaust front end. Press test key on the analyzer. Adjust the air volume adjustment screw and read CO reading on the analyzer.

CO standard value: 1.0~1.5 %

Accelerate in gradual increments, make sure both rpm and CO value are in standard values after engine running in stable. If rpm and CO value fluctuated, repeat the procedures described above for adjusting to standard value.

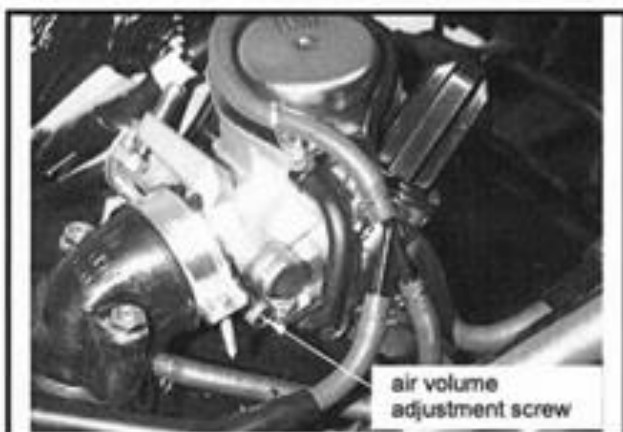
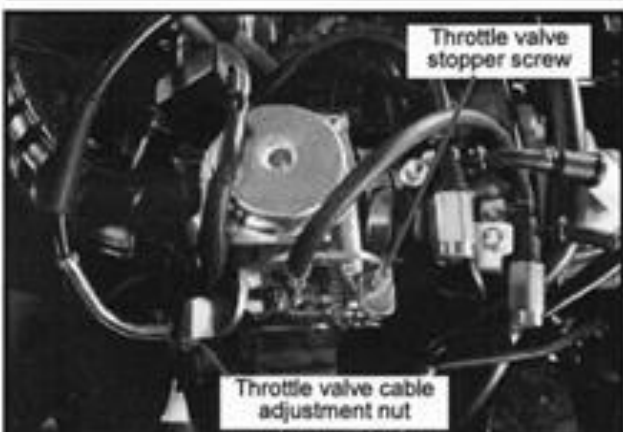
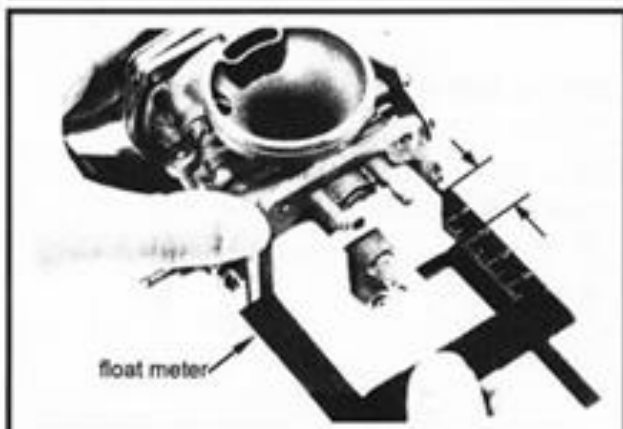

5. FUEL SYSTEM

AIR CLEANER

Removal

Remove the seat .
 Remove the luggage box assembly (4 bolts).
 Loosen the clamp strip of air cleaner.
 Remove evaporative return hose.
 Remove the air cleaner body bolts (2 bolts).
 Remove the air cleaner.



Installation

Install the air cleaner in the reverse order of removal.



Air Cleaner Element Cleaning

Remove the air cleaner cover (6 screws).



Remove the air cleaner element (2 screws).
 With compressed air to clean dirty around the element. Replace it if it is too dirty to clean.

Cautions

The air cleaner element is made of paper so do not soap it into water or wash it with water.

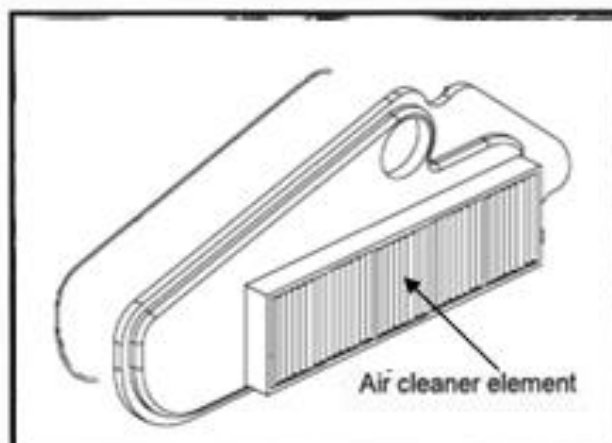

5. FUEL SYSTEM

ELECTRIC CARBURETOR TPS RESET

1. TPS Mechanical adjustments

- 1) TPS Initial voltage: $0.66 \pm 0.6V$
- 2) If value not on this range loose bolt then adjust TPS body and check by diagnostic tool



2. Check MAP version

Before adjust the idle speed should be checking MAP version by diagnostics while turn the ignition switch on

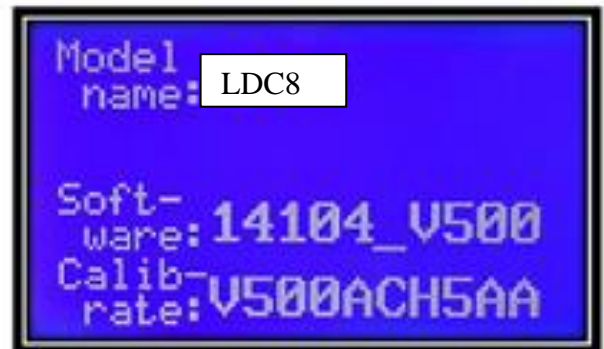

3. TPS Reset procedure:

- 1) ↵ Select Adjust icon



5. FUEL SYSTEM

2) Select TPI Reset



3) Complete throttle fully and closed within five seconds once



4) After throttle operation, the monitor display is completed



5) Go back to the Data Analyze and select it



5. FUEL SYSTEM

4. Check TPS Position

1) Initial voltage of TPS : 0.6 V ~ 0.72 V



2) TPS full open: 95%-100%.
Voltage value: 3.7 V ~ 4.2 V

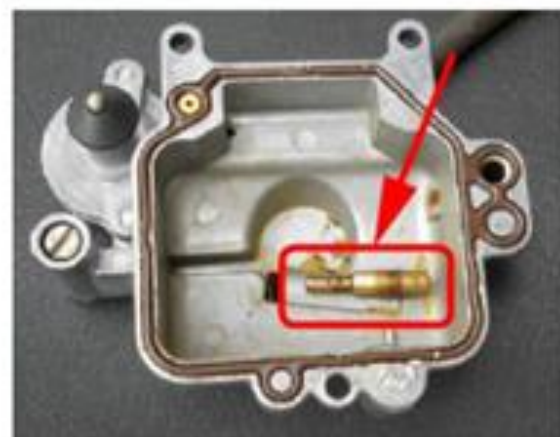
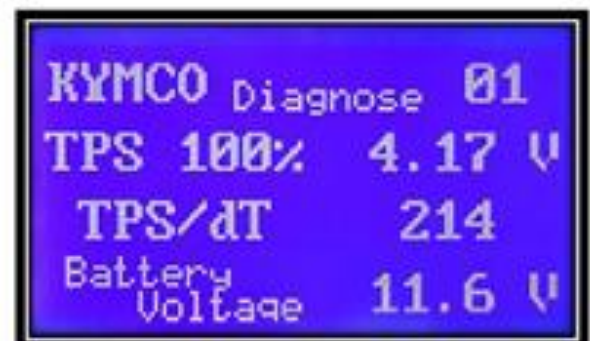

When you finish TPS reset and cranking the engine it can be starts then a little time engine stall

5. FUEL SYSTEM

Electronic Carburetor System

Collect engine speed signal, oxygen sensor signal, engine temperature signals, battery voltage, etc.,

Through the calculation of ECU control strategy, and ignition signal output PWM control signal,

Realize the solenoid valve for carburetor main oil system and idle oil system for real-time additional air, precision digital control of air-fuel ratio and ignition system.

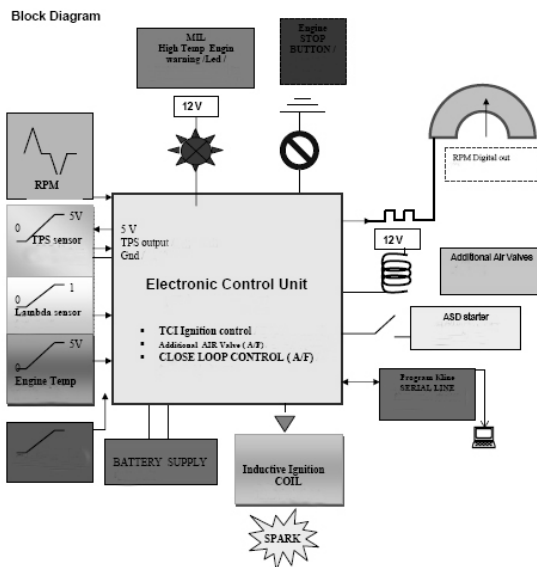

Electronic Carburetor parts installation location

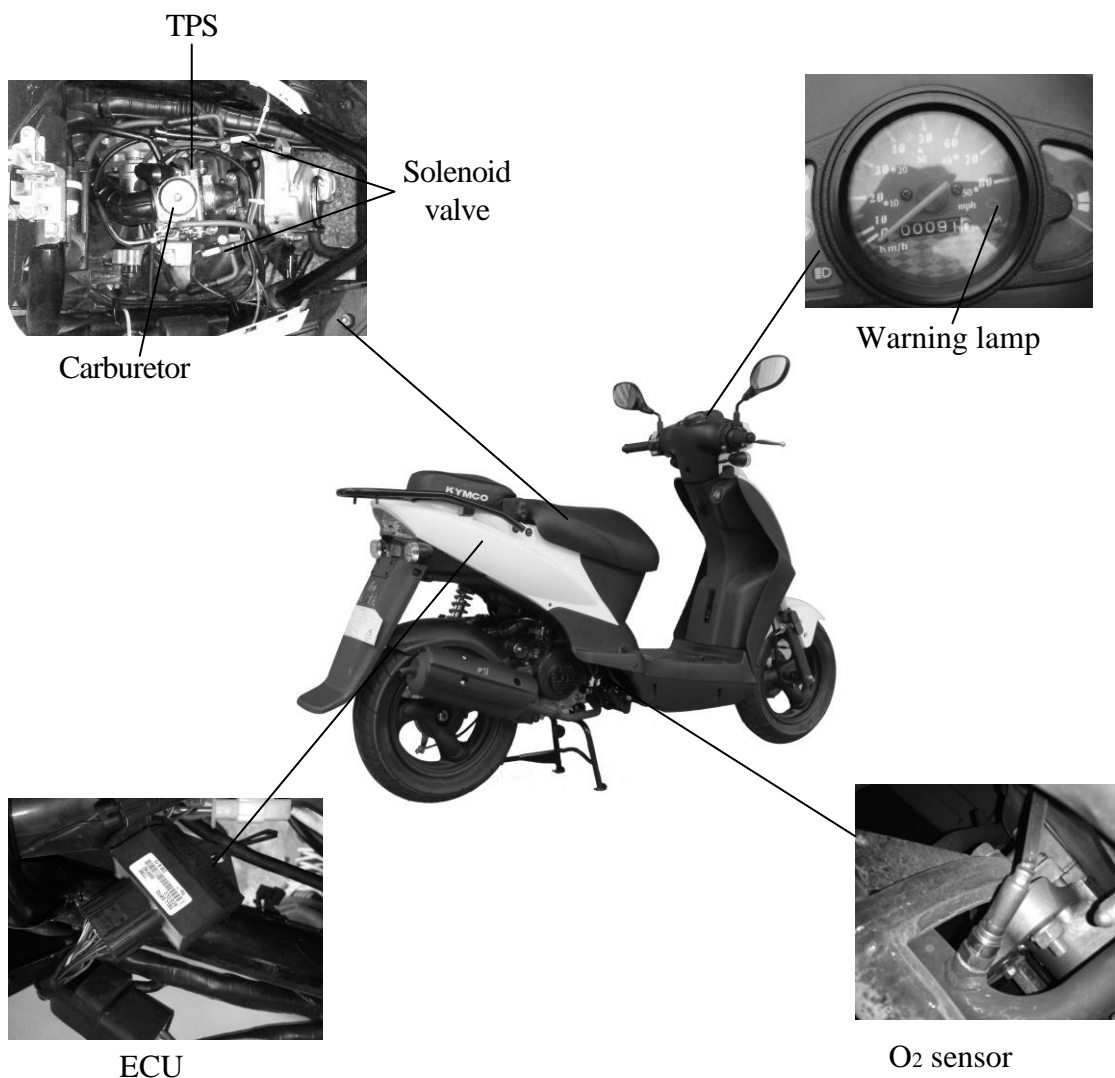

5. FUEL SYSTEM

Error codes

When a fault or error is detected ECU send an error code to DEUSS (column 1) and use MIL LED to report (column 3)

Error table			
Code	Error	MIL LED	Description
10	Err_Flash_Chk		Checksum error of data in flash memory The ECU usually reset the value in the default map, it could appear during a map loading interruption
11	Err_Flash_Dev		Flash error, it is possible a hardware error
104	Err_Teng_CC	(0,3)	Engine temperature sensor in short circuit
105	Err_Teng_CA	1.5 sec off 3 blinks	Engine temperature sensor in open circuit
120	Err_Air_CC	(0,2)	Air valve in short circuit
121	Err_Air_CA	1.5 sec off 2 blinks	Air valve in open circuit The fault check is activated when: Air_En = 1 Output PWM air valve not 0 Engine is running
130	Err_Starter_CC	(0,5) 1.5 sec off 5 blinks	Starter in short circuit Check made if ASD starter PWM \geq 5%, it works only if engine is running
131	Err_Starter_CA		Starter in open circuit Check made if ASD starter PWM \leq 95%, it works even if engine is not running
138	Err_Speed_CC	(0,6)	Speed sensor in short circuit or open circuit
139	Err_Speed_CA	1.5 sec off 6 blinks	Detected if engine is running over certain RPM and signal is fixed low or high for at least 3s Every fault conditions is immediately deleted when activity sensor is detected
170	Err_Tps_Lo	(0,1)	TPS signal lower than 0,2V

5. FUEL SYSTEM

171	Err_Tps_Hi		TPS signal higher than 4,8V
190	Err_Lambda_CC	(0,4) 1.5 sec off 4 blinks	Lambda sensor short circuit to GND or 5 Volt Check if key on and engine is not running Fault detected after 5 seconds
192	Err_Lambda_NA		<p>If TPS_En = 0, the conditions test are: RPM bigger than 3000 Engine run time bigger than 3 minutes</p> <p>If there's no sensor activity for ClcCheckTime_NoTps seconds, the fault is activated (default value 300 seconds)</p> <p>If TPS_En = 1, the conditions test are: RPM bigger than 3000 Engine run time bigger than 3 minutes TPS bigger than Clc_TPSEnLo_Diag</p> <p>If there's no sensor activity for ClcCheckTime_TpsPresent seconds, the fault is activated (default value 30 seconds)</p> <p>Sensor check for dialer: Key OFF > Key ON RPM bigger than 6000 for 1 minute within 2 minutes since 2 minutes engine's running If there's no sensor activity, the fault is activated</p> <p>Every fault conditions is immediately deleted when activity sensor is detected</p>

5. FUEL SYSTEM

Warning Lamp

Electronically controlled carburetor fails, motorcycle running abnormal or cannot be started,
The warning lamp is up, Prompt the user for repair.

ECU

ECU is the electronic control unit, and its maximum working voltage to 18 v. ECU is through a 16-bit chip,

The speed signal, oxygen sensor signal, engine temperature sensor signal, trigger signal, such as internal control logic processing, realize the ignition coil, solenoid valve, warning lamp etc.

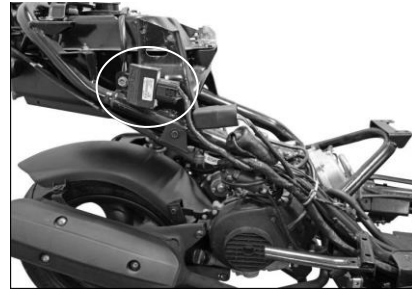

- ***
- Do not disconnect the battery negative (-) or positive (+) cable during the ignition switch “ON”, it may cause ECU damage.
 - Do not disconnect or connect the ECU connector while engine is running, it may cause the ECU damage.

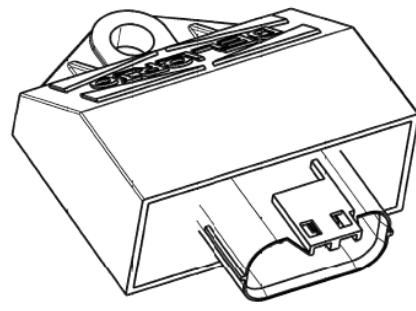

PIN ASSIGNMENT

Pin Number	Signal
1	Vbat
2	Signal GND
3	O2Sen In
4	TPS In / TPS
5	Pick Up
6	Gear In
7	Tune Switch
8	PWM Air Out / PWM
9	ASD Starter
10	+5V Sensor Supply / +5V
11	Free In
12	K-Line
13	NTC Eng In
14	Eng Stop
15	Not Available
16	MIL Out
17	Power GND
18	IGN Out



ECU CONFIGURATION

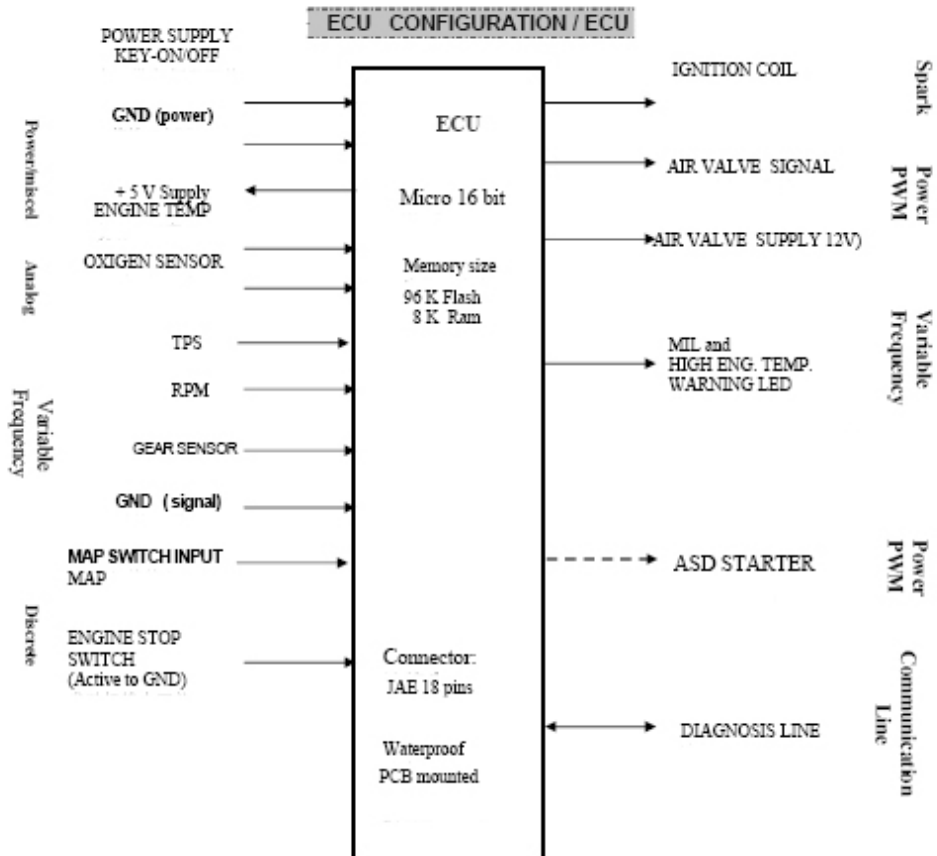

ECU INSPECT

1. Connect the diagnostic tool to the motorcycle diagnosis connector
2. Turn the main switch on, don't start the engine, make sure the diagnostic software detects the ECU.
3. Check if the ECU version. MAP ID is correct.
4. Check for any failure code in the diagnostic software
5. Inspect and repair the electric parts according to the failure code, make sure to eliminate the failure code with the software.
6. Start the engine, inspect all the parameters in the software.

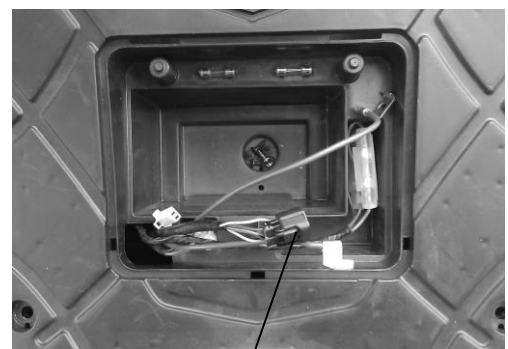

Diagnosis tool joint

5. FUEL SYSTEM

SOLENOID VALVE

Solenoid valve is driven by the air-fuel ratio signal of ECU, different amount of air is supplied to the carburetor idle speed air tube according to different PWM signal, to maintain the ideal air-fuel ratio 14.7. Air cleaner is connected to the inlet tube of the solenoid valve, it can prevent clog of carburetor by filtering dust in the air.



Solenoid valve

SOLENOID VALVE INSPECT

1. Check if the connecting tube between the solenoid valve and the carburetor is fit properly, if the solenoid valve wire is connected properly.
2. Check if the air cleaner is clogged
3. Measure the resistance between the solenoid valve wires with a multimeter.

RESISTANCE: 70Ω~85Ω



Solenoid valve wire

Solenoid valve air cleaner malfunctions and solutions

1. The connecting tube between the solenoid valve and the carburetor loose → reconnect properly
2. The solenoid valve wires connector poor contact → reconnect properly
3. Air cleaner clogged → replace with a new one or clean the filter to make it impeded.
4. Resistance between the solenoid valve wires over 85 Ω → replace the solenoid valve with a new one.
5. Unstable idle speed 、 poor acceleration → check if the connecting tube between the solenoid valve and the carburetor is fit properly, if the carburetor is clogged, or replace the solenoid valve with a new one.

5. FUEL SYSTEM

TPS FUNCTION

TPS mainly consists of a variable resistance chip. It is installed on the throttle axle, the resistance will vary corresponding to the rotation of the throttle and TPS will send a linear changing voltage signal, so the ECU can detect the throttle position and calculate how much air shall be supplied and control ignition timing. TPS has 3 pins, one 5V power input, one voltage output pin, one ground pin.



TPS

TPS INSPECTION

1. Use a three-phase multi-functional meter(V DC) to measure the voltage
 - A. Connect the Three-phase meter – cable to TPS ground pin
 - B. Connect the Three-phase meter+ cable to TPS input pin
2. Voltage output confirm(Use a probe tool)
 - A. Connect the Three-phase meter – cable to TPS ground pin
 - B. Connect the Three-phase meter+ cable to TPS output pin
 - C. Measure the voltage when the throttle is fully open and fully closed.

Working voltage : $5.0 \pm 0.1V$

Voltage (fully closed): 0.2~1.0 V

Voltage (fully open): 3.2~4.8V

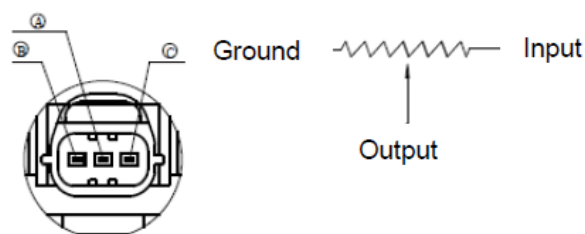

TPS MALFUNCTIONS AND SOLUTIONS

TPS working voltage is beyond normal range, or voltage output is abnormal when throttle is full open or fully closed → check if the main wiring is normal or replace the TPS with a new one. During installation, make sure the resistance of ETS is 0.6~0.8V when throttle is fully closed. After installation, check the working voltage and voltage when throttle is fully open and fully closed.

No.	Note
A	Ground pin
B	Output pin
C	Input pin

5. FUEL SYSTEM

O2 SENSOR

O2 SENSOR detects the level of O2 in the exhaust pipe and send the signal to ECU,to change air supply of the solenoid valve and change the air-fuel ratio in the carburetor.If the level of O2 is too low,it means the mixed air is too thick and there will be too much HC and CO in the exhaust gas.Otherwise it means the mixed air is too thin,and there will be too much NOx in the exhaust gas.ECU will maintain air-fuel ratio 14.5~14.7 according to the signal of O2 SENSOR,thus minimize CO/HC/Nox in the exhaust gas and reduce pollution.

O2 SENSOR INSPECTION

1. Start the engine
 2. Keep full throttle for 3 minutes
 3. Check if the fault light is flashing or not
- If the flash frequency of the faulty light is 4 at a time,it means malfunction.

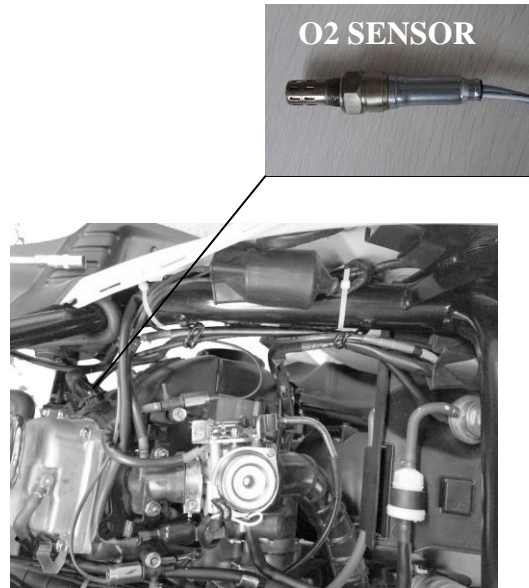

O2 SENSOR MALFUNCTIONS AND SOLUTIONS

- 1.Connector poor contact→check if the main wiring is normal
2. O2 SENSOR damaged→replace with a new one and check again

The input volt range is : 0V – 1V

ENGINE TEMPERATURE SENSOR

ETS mainly consists of a negative temperature coefficient thermistor(Resistance diminish when temperature rising).It has 2 pins,one voltage output pin and one ground pin.ETS is installed on the cylinder head and its resistance varies with changing temperature,it will send a voltage signal to ECU,ECU will change air supply of the solenoid valve and correct the ignition timing.

ETS INSPECTION

- 1.Disconnect the connector of the ETS
- 2.Measure the resistance between the 2 pins of ETS with a three-phase multi-functional meter.

Temperature(°C)	Resistance(KΩ)
-20	955 ± 48.5
25	124.8 ± 6.4
40	53.4 ± 2.8
80	12.5 ± 0.65

DIAGNOSTIC REPORT 45KM/H model

Reason of repair: <input type="checkbox"/> Maintenance <input type="checkbox"/> Breakdown			
Item	Data	Reference	Memo
ECU Version	ECU No		
	Hardware Ver		
	Software Ver	14105-V500	
	Calibration Ver	V500ACH5AA	
	Model Name		
(Hot Engine) Before Repair	EngineSpeed IDLE(rpm)	2000 ± 100 rpm	
	MAPSample (kPa)	52 ~ 68 kpa	
	Negative Pressure	> 180mmHg	> 220mmHg after break in
	PWM air compensation	45-90%	keep the engine rev 5000-5500rpm
	Air Temp.(°C)	environ.temp ±2 °C	
	Engine Temp. (°C)	40 ± 5 °C (Environ temp 25°C) 30 ± 3°C (Environ temp 0°C)	
	O ₂ sensor voltage	0.2V-0.6V	keep the engine rev 5000-5500rpm
	CO% ajustment screw	2 1/4±1/2	
	IDLE CO(%))	4 ± 0.5 %	without cylinder head air compensation
	HC ppm	< 700ppm	
	Battery voltage	> 12V	
(Hot Engine) After Repair	Battery voltage	> 12V	
	EngineSpeed IDLE(rpm)	2000 ± 100 rpm	
	MAPSample (kPa)	52 ~ 68 kpa	
	Negative Pressure	> 180mmHg	> 220mmHg after break in
	PWM air compensation	45-90%	keep the engine rev 5000-5500rpm
	Air Temp.(°C)	environ.temp ±2 °C	
	Engine Temp. (°C)	40 ± 5 °C (Environ temp 25°C) 30 ± 3°C (Environ temp 0°C)	
	O ₂ sensor voltage	0.2V-0.6V	keep the engine rev 5000-5500rpm
	CO% ajustment screw	2 1/4±1/2	
	IDLE CO(%))	4 ± 0.5 %	without cylinder head air compensation
	HC ppm	< 700ppm	
Repair description		Repair Process	

DIAGNOSTIC REPORT 25KM/H model

Reason of repair: <input type="checkbox"/> Maintenance <input type="checkbox"/> Breakdown			
Item	Data	Reference	Memo
ECU Version	ECU No		
	Hardware Ver		
	Software Ver	14105-V500	
	Calibration Ver	V500ACH5AA	
	Model Name		
(Hot Engine) Before Repair	EngineSpeed IDLE(rpm)	2000 ± 100 rpm	
	MAPSample (kPa)	52 ~ 68 kpa	
	Negative Pressure	> 180mmHg	> 220mmHg after break in
	PWM air compensation	45-90%	keep the engine rev 5000-5500rpm
	Air Temp.(°C)	environ.temp ±2 °C	
	Engine Temp. (°C)	40 ± 5 °C (Environ temp 25°C)	30 ± 3°C (Environ temp 0°C)
	O ₂ sensor voltage	0.2V-0.6V	keep the engine rev 5000-5500rpm
	CO% ajustment screw	2 1/4±1/2	
	IDLE CO(%)	2.3 ± 0.5%	with cylinder head air compensation
	HC ppm	< 700ppm	
	Battery voltage	> 12V	
(Hot Engine) After Repair	Battery voltage	> 12V	
	EngineSpeed IDLE(rpm)	2000 ± 100 rpm	
	MAPSample (kPa)	52 ~ 68 kpa	
	Negative Pressure	> 180mmHg	> 220mmHg after break in
	PWM air compensation	45-90%	keep the engine rev 5000-5500rpm
	Air Temp.(°C)	environ.temp ±2 °C	
	Engine Temp. (°C)	40 ± 5 °C (Environ temp 25°C)	30 ± 3°C (Environ temp 0°C)
	O ₂ sensor voltage	0.2V-0.6V	keep the engine rev 5000-5500rpm
	CO% ajustment screw	2 1/4±1/2	
	IDLE CO(%)	2.3 ± 0.5 %	with cylinder head air compensation
	HC ppm	< 700ppm	
Repair description		Repair Process	

6. ENGINE REMOVAL/INSTALLATION

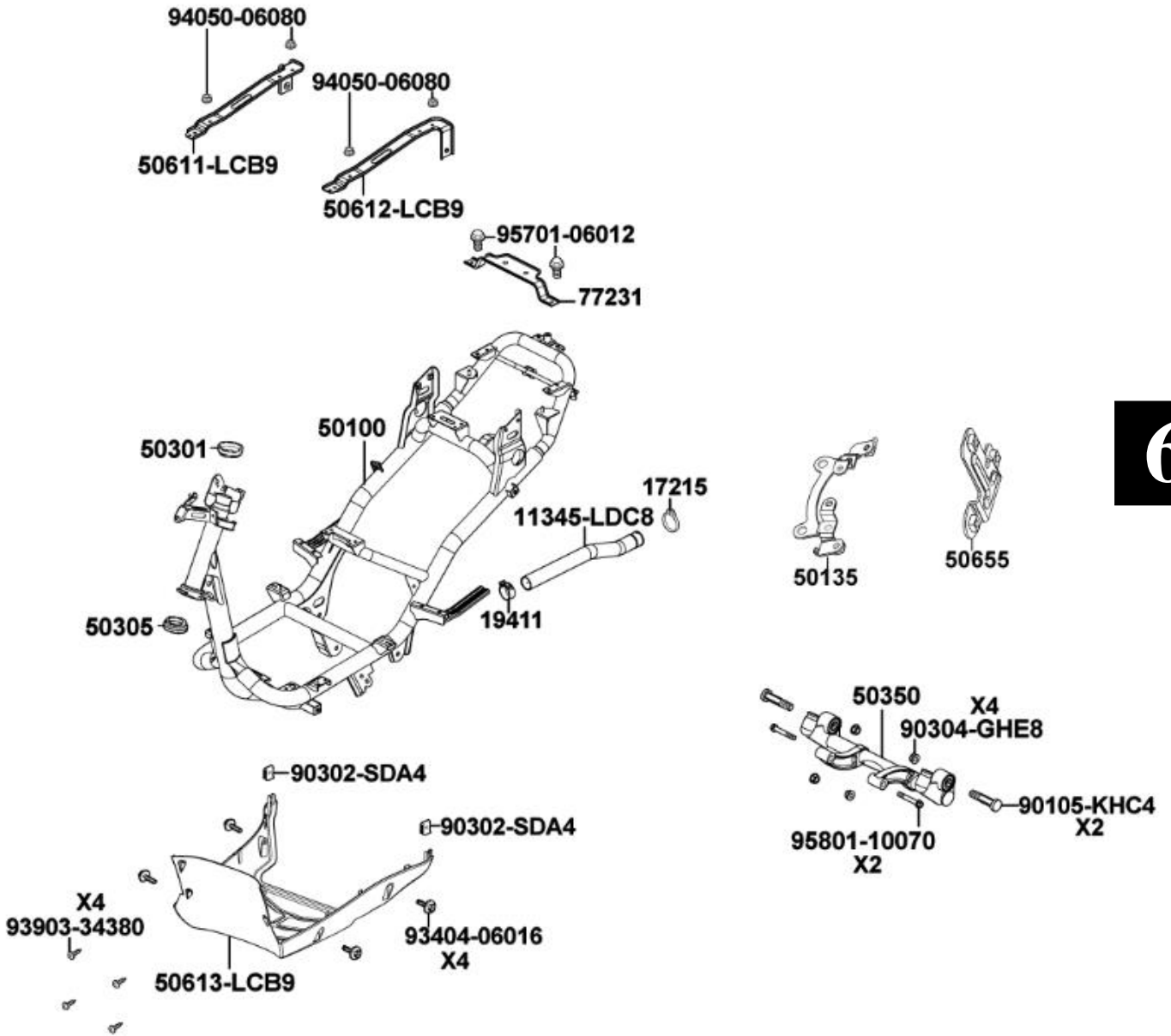

6

SERVICE INFORMATION	6-1	ENGINE INSTALLATION	6-4
ENGINE REMOVAL	6-2		

SERVICE INFORMATION

GENERAL INSTRUCTIONS

- A floor jack or other adjustable support is required to support and maneuver the engine. Be careful not to damage the motorcycle body, cables and wires during engine removal.
- Use shop towels to protect the motorcycle body during engine removal.
- Parts requiring engine removal for servicing:
 - Crankcase
 - Crankshaft

6. ENGINE REMOVAL/INSTALLATION

AGILITY 50

ENGINE REMOVAL

Disconnect the battery negative cable.
 Remove the frame body cover. (⇒2-3)
 Disconnect the spark plug high tension wire.
 Disconnect the auto bystarter wire connector.
 Disconnect the A.C. generator wire connector.

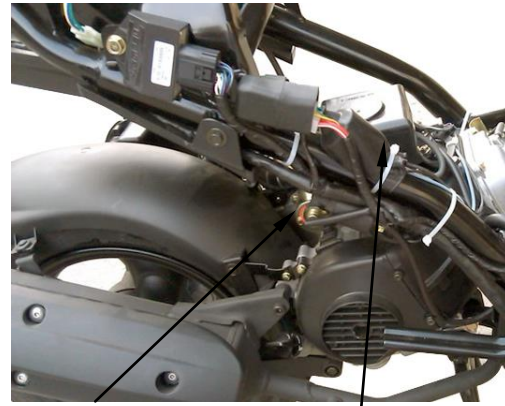

Negative Cable Auto Bystarter Wire Connector

Disconnect the starter motor cable and earth cable from the starter motor.
 Remove the fuel tube.



Earth Cable Fuel tube Starter Motor Cable

Remove the spark plug cap.

Remove the O₂ sensor.



Spark Plug High Tension Wire

Disconnect the vacuum tube.
 Loosen the throttle cable adjusting nut and lock nut, and disconnect the throttle cable from the carburetor.
 Disconnect the TPS and ETS.

Band

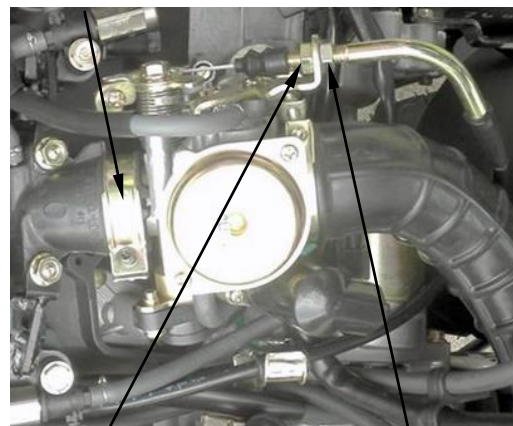

Lock Nut Adjusting Nut

6. ENGINE REMOVAL/INSTALLATION

AGILITY 50

Loosen the drive belt air cleaner connecting tube band screw and remove the connecting tube.

Air Tube Band

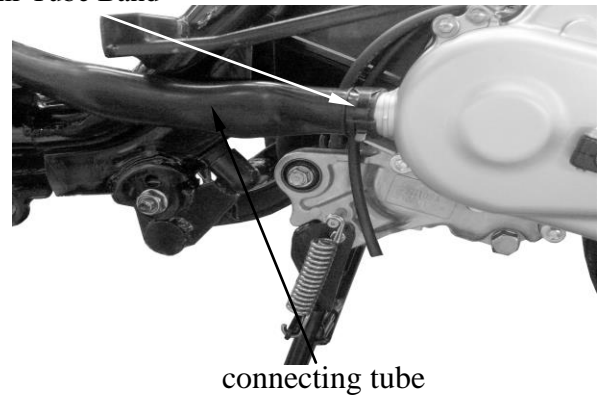

Remove the rear brake adjusting nut, connector pin rear brake cable.



Adjusting Nut

Remove the rear shock absorber upper mount bolt.

Rear Shock Absorber Upper Mount Bolt



Remove the engine mounting bolt and move the motorcycle forward to separate it from the engine.
Support the motorcycle with a floor jack.

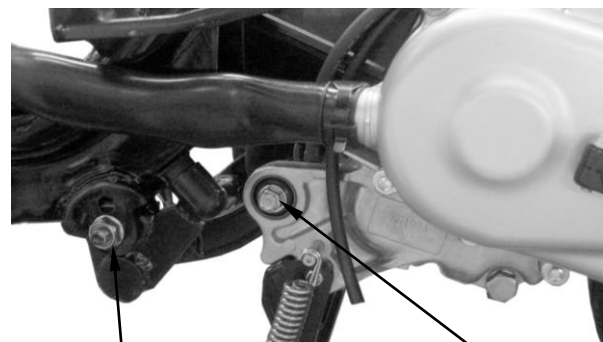

Engine Hanger Bracket Bolt

Engine Mounting Bolt

6. ENGINE REMOVAL/INSTALLATION

AGILITY 50

ENGINE HANGER BRACKET REMOVAL

Remove the return spring from the main stand.
Remove the main stand.

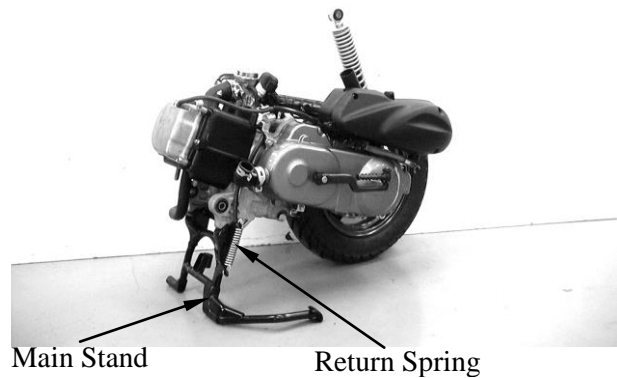

Remove the engine hanger bracket bolts and engine hanger bracket.
Inspect the engine hanger bushings and stopper spring for wear or damage.

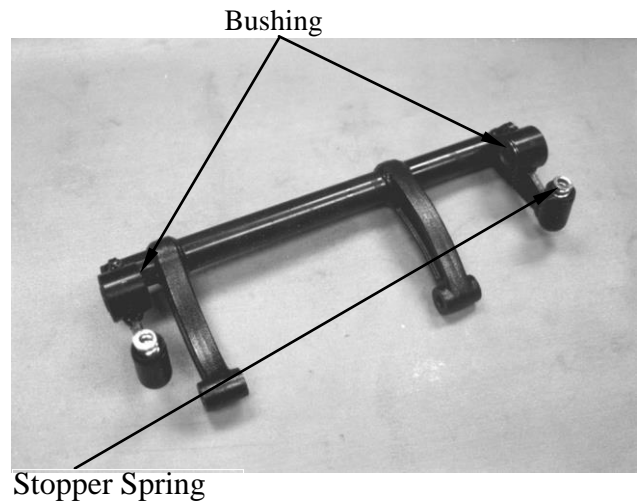

ENGINE HANGER BRACKET INSTALLATION

Install the engine hanger bracket to the chassis and tighten the bolt.
Install the main stand onto the engine and install the return spring.

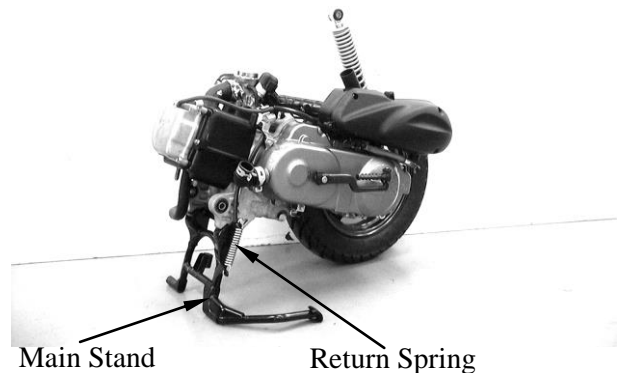

ENGINE INSTALLATION

Install the engine and tighten the engine mounting bolt.

Torque: 4.5~5.5kgf-m

Tighten the rear shock absorber upper mount bolt.

Torque: 4.5~5.5kgf-m

Engine Mounting Bolt

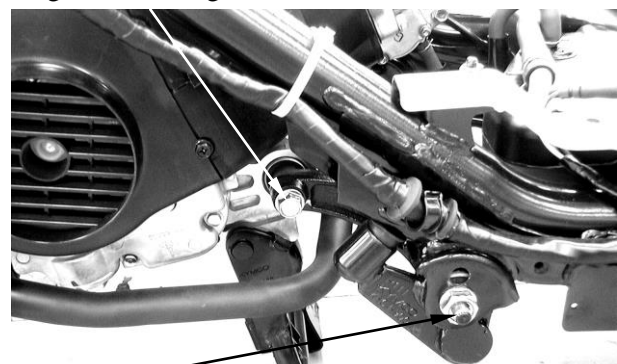

Engine Hanger Bracket Bolt

6. ENGINE REMOVAL/INSTALLATION

Install the removed parts in the reverse order of removal.

* Route the wires and cables properly.

After installation, inspect and adjust the following:

- Throttle grip free play (⇒3-3)
- Rear brake adjustment (⇒3-8)

Rear Shock Absorber Upper Mount Bolt



7. CYLINDER HEAD/VALVES

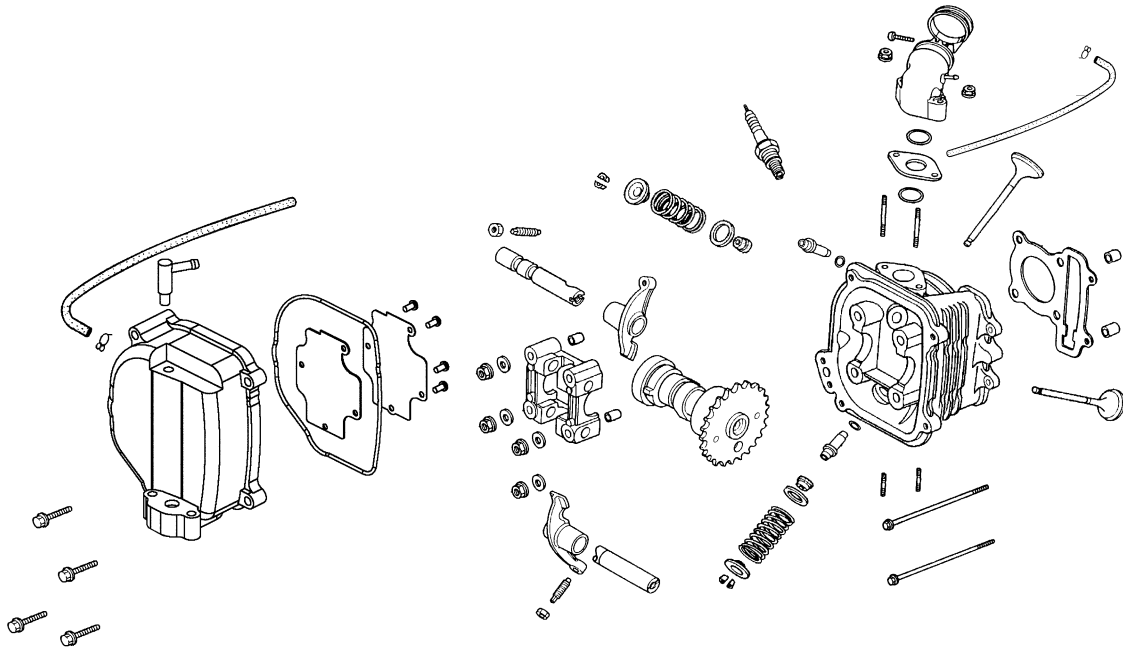

7

7. CYLINDER HEAD/VALVES

SERVICE INFORMATION.....	7-1	CYLINDER HEAD DISASSEMBLY	7-7
TROUBLESHOOTING	7-2	CYLINDER HEAD ASSEMBLY	7-8
CAMSHAFT REMOVAL.....	7-3	CYLINDER HEAD INSTALLATION.....	7-8
CYLINDER HEAD REMOVAL	7-5	CAMSHAFT INSTALLATION	7-9

SERVICE INFORMATION

GENERAL INSTRUCTIONS

- The cylinder head can be serviced with the engine installed in the frame.
- When assembling, apply molybdenum disulfide grease or engine oil to the valve guide movable parts, valve arm and camshaft sliding surfaces for initial lubrication.
- The camshaft is lubricated by engine oil through the cylinder head engine oil passages. Clean and unclog the oil passages before assembling the cylinder head.
- After disassembly, clean the removed parts and dry them with compressed air before inspection.
- After removal, mark and arrange the removed parts in order. When assembling, install them in the reverse order of removal.

SPECIFICATIONS

Item		Standard (mm)	Service Limit (mm)
Valve clearance (cold)	IN	0.04	—
	EX	0.04	—
Cylinder head compression		15±2 kg/cm ²	—
Cylinder head warpage		—	0.05
Camshaft cam height	IN	25.761±0.05	25.361
	EX	25.562±0.05	25.162
Valve rocker arm I.D.	IN	10.000-10.015	10.10
	EX	10.000-10.015	10.10
Valve rocker arm shaft O.D.	IN	9.972-9.987	9.91
	EX	9.972-9.987	9.91
Valve seat width	IN	1.0	1.8
	EX	1.0	1.8
Valve stem O.D.	IN	4.975-4.990	4.9
	EX	4.955-4.970	4.9
Valve guide I.D.	IN	5.000-5.012	5.03
	EX	5.000-5.012	5.03
Valve stem-to-guide clearance	IN	0.010-0.037	0.08
	EX	0.030-0.057	0.1
Valve spring free length		35.25	29.1

7. CYLINDER HEAD/VALVES

TORQUE VALUES

Cylinder head nut	1.8~2.2kgf-m	Apply engine oil to threads
Valve clearance adjusting nut	0.7~1.1kgf-m	Apply engine oil to threads

SPECIAL TOOLS

Valve spring compressor

TROUBLESHOOTING

- The poor cylinder head operation can be diagnosed by a compression test or by tracing engine top-end noises.

Poor performance at idle speed

- Compression too low

Compression too low

- Incorrect valve clearance adjustment
- Burned or bent valves
- Incorrect valve timing
- Broken valve spring
- Poor valve and seat contact
- Leaking cylinder head gasket
- Warped or cracked cylinder head
- Poorly installed spark plug

Compression too high

- Excessive carbon build-up in combustion chamber

White smoke from exhaust muffler

- Worn valve stem or valve guide
- Damaged valve stem seal

Abnormal noise

- Incorrect valve clearance adjustment
- Sticking valve or broken valve spring
- Damaged or worn camshaft
- Worn cam chain guide
- Worn camshaft and rocker arm

7. CYLINDER HEAD/VALVES

CAMSHAFT REMOVAL

Remove the center cover. (⇒2-3)
 Remove the frame center.
 Remove the four cylinder head cover bolts to remove the cylinder head cover.

Cylinder Head Cover

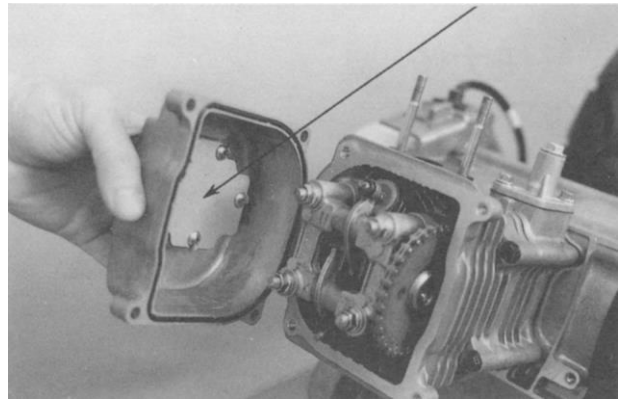

Remove the cam chain tensioner sealing bolt and spring.
 Remove the two bolts attaching the cam chain tensioner and the tensioner.

Sealing Bolt

Bolts

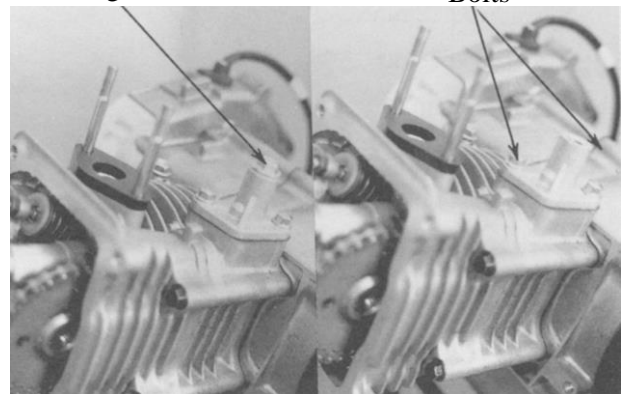

Turn the flywheel counterclockwise so that the "T" mark on the flywheel aligns with the index mark on the crankcase to bring the round hole on the camshaft gear facing up to the top dead center on the compression stroke.

Camshaft Gear

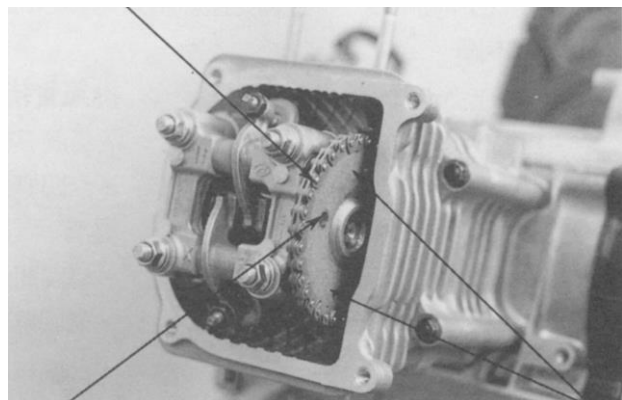

Round Hole

Punch Marks

Washer Nut

Remove the two cylinder head bolts.
 Remove the four cylinder head nuts and washers.
 Remove the camshaft holder.

* Diagonally loosen the cylinder head nuts in 2 or 3 times.

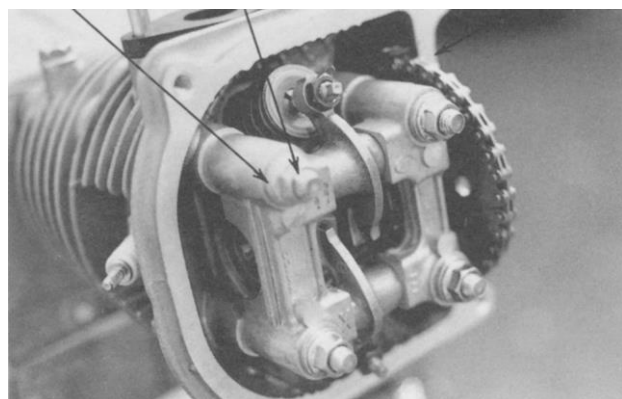

7. CYLINDER HEAD/VALVES

Remove the camshaft holder and dowel pins.

Camshaft Holder

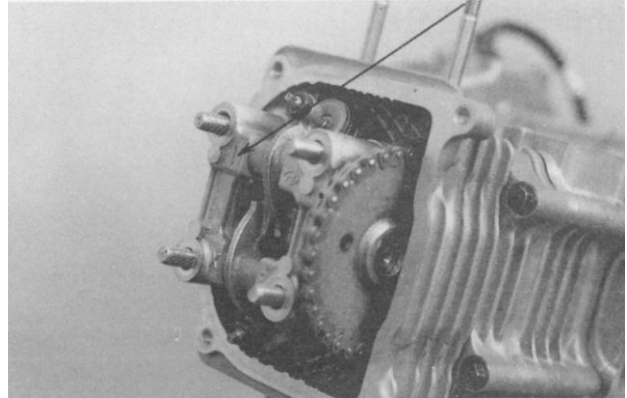

Remove the camshaft gear from the cam chain and remove the camshaft.

Camshaft

Dowel Pins

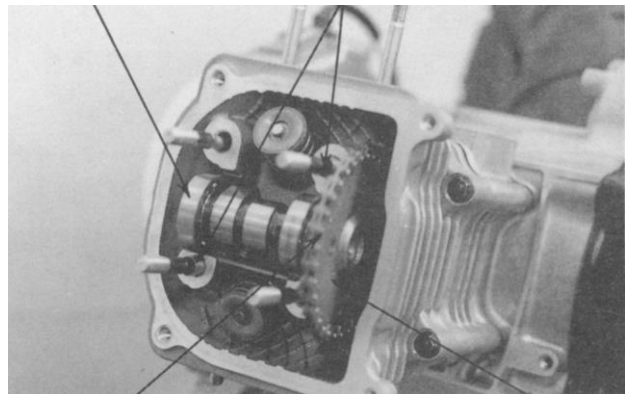

Cam Chain

Camshaft Gear

CAMSHAFT INSPECTION

Check each cam lobe for wear or damage.
Measure the cam lobe height.

Service Limits:

IN : 25.361mm replace if below

EX: 25.162mm replace if below

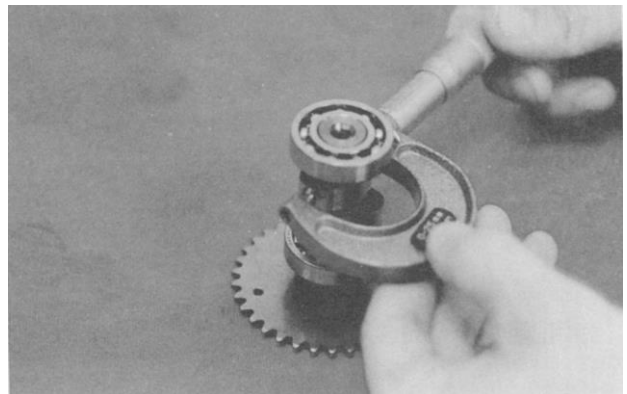

Check each camshaft bearing for play or damage.
Replace the camshaft assembly with a new one if the bearings are noisy or have excessive play.

Camshaft Bearings

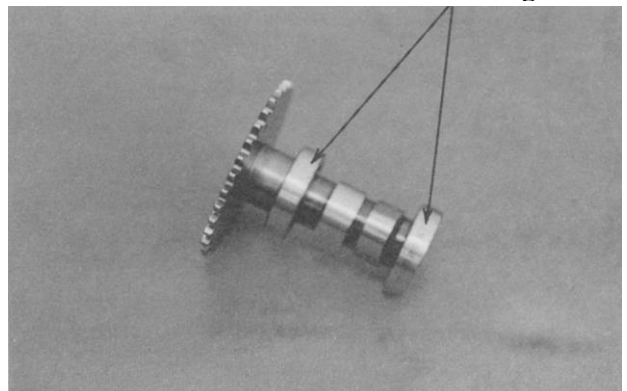

7. CYLINDER HEAD/VALVES

CAMSHAFT HOLDER DISASSEMBLY

Take out the valve rocker arm shafts using a 5mm bolt.
Remove the valve rocker arms.

Rocker Arm Shaft

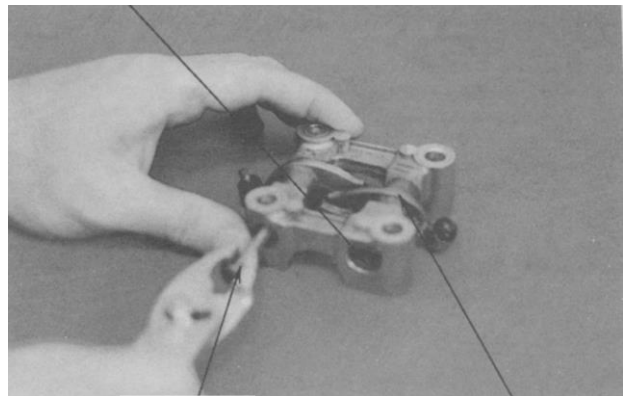

5mm Bolt

Rocker Arm

CAMSHAFT HOLDER INSPECTION

Inspect the camshaft holder, valve rocker arms and rocker arm shafts for wear or damage.

* If the valve rocker arm contact surface is worn, check each cam lobe for wear or damage.

Camshaft Holder

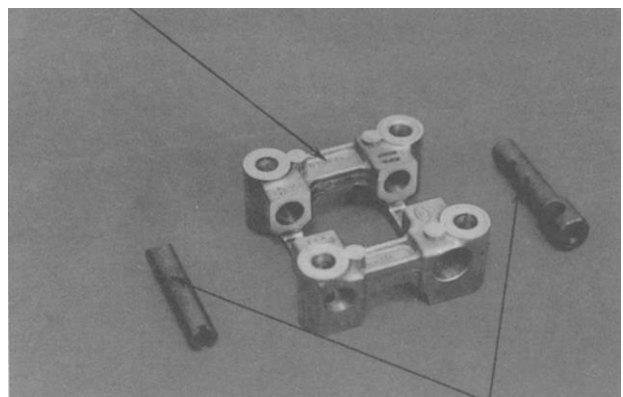

Rocker Arm Shafts

Measure the I.D. of each valve rocker arm.

Service Limits: IN:10.10mm replace if over
EX:10.10mm replace if over

Measure each rocker arm shaft O.D.

Service Limits: IN: 9.91mm replace if over
EX: 9.91mm replace if over

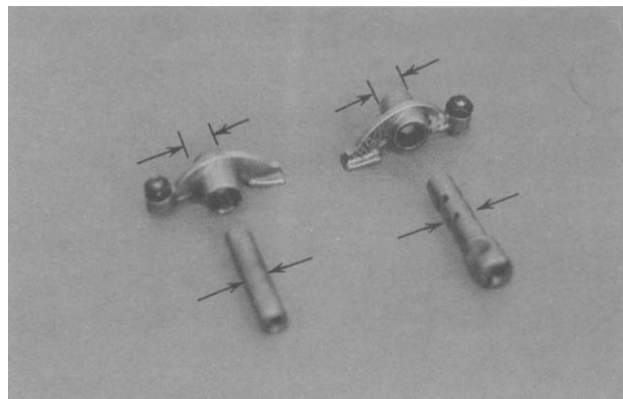

CYLINDER HEAD REMOVAL

Remove the camshaft. (⇒7-3)
Remove the carburetor. (⇒5-5)
Remove the exhaust muffler. (⇒2-5)
Remove the carburetor intake manifold.

Intake Manifold



7. CYLINDER HEAD/VALVES

Remove the cooling fan cover. (⇒14-6)
 Remove the engine cover bolts and screws.
 Separate the engine cover joint claws.

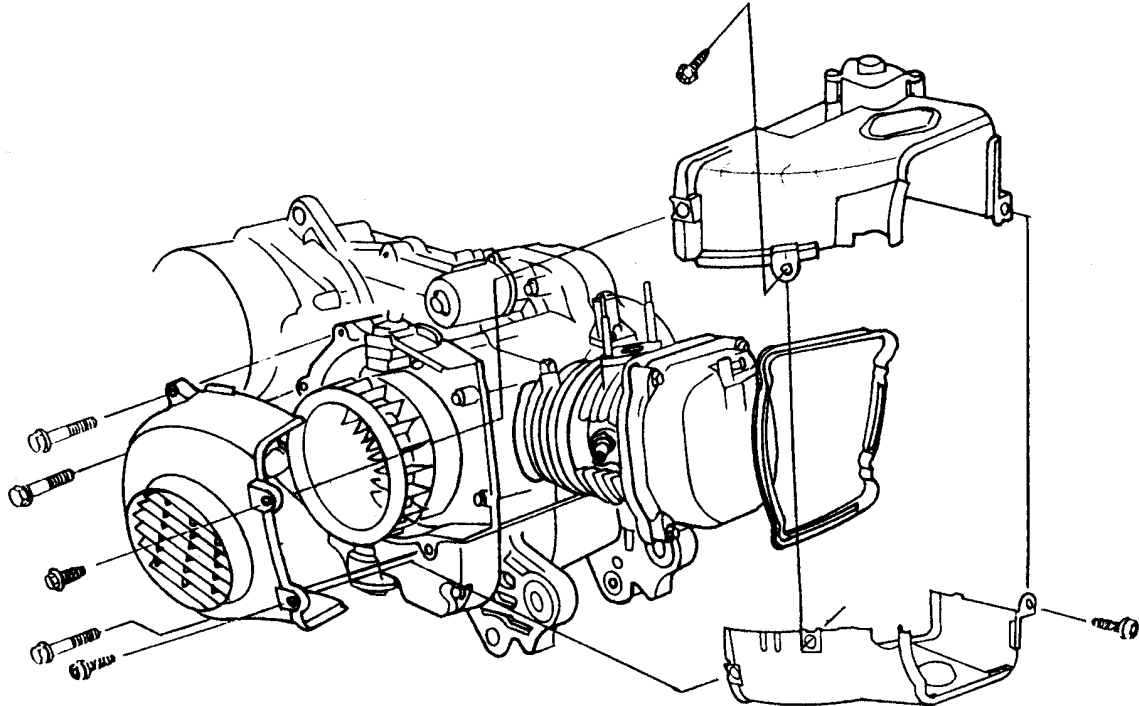

Remove the cylinder head.

Cylinder Head

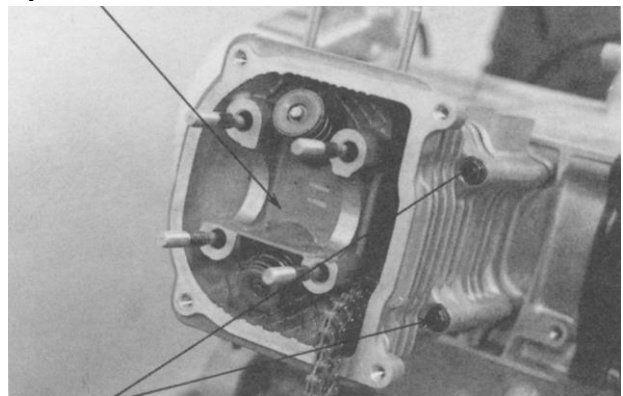

Bolts

Remove the dowel pins and cylinder head gasket.
 Remove the cam chain guide.

Dowel Pins

Cylinder Head Gasket

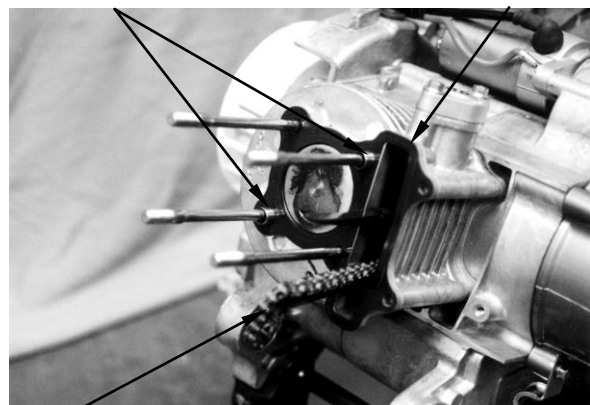

Cam Chain Guide

7. CYLINDER HEAD/VALVES

CYLINDER HEAD DISASSEMBLY

Remove the valve spring cotters, retainers, springs, spring seats and valve stem seals using a valve spring compressor.

- * Special
 - Be sure to compress the valve springs with a valve spring compressor.
 - Mark all disassembled parts to ensure correct reassembly.

Special

Valve Spring Compressor

Valve Spring Compressor Attachment

Valve Spring Compressor

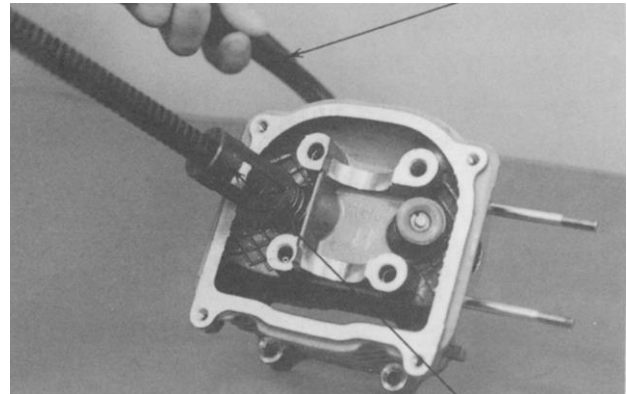

Valve Spring Compressor Attachment

Remove carbon deposits from the combustion chamber.

Clean off any gasket material from the cylinder head mating surface.

- * Special Be careful not to damage the cylinder head mating surface.

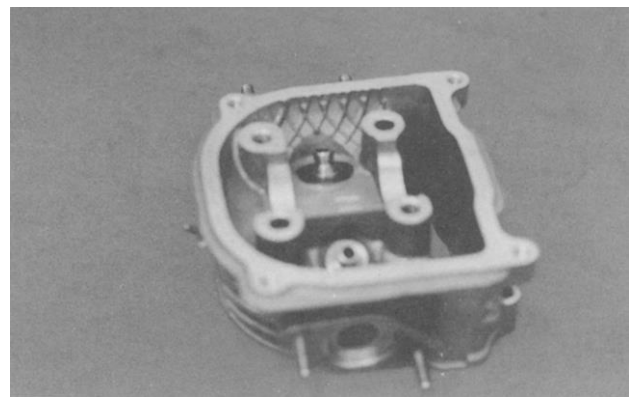

INSPECTION

CYLINDER HEAD

Check the spark plug hole and valve areas for cracks.

Check the cylinder head for warpage with a straight edge and feeler gauge.

Service Limit: 0.05mm repair or replace if over

VALVE SPRING FREE LENGTH

Measure the free length of the springs.

Service Limits: 29.1mm replace if below

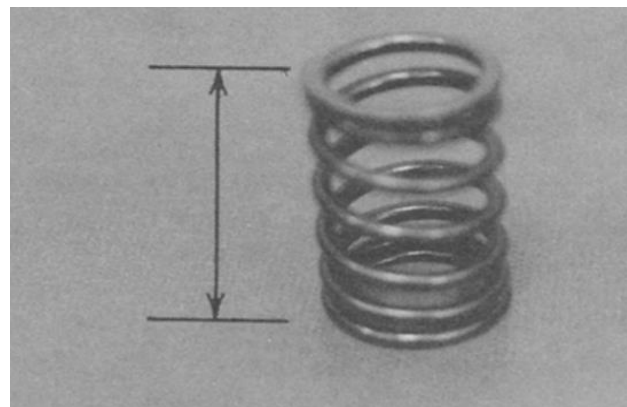

7. CYLINDER HEAD/VALVES

VALVE/ VALVE GUIDE

Inspect each valve for bending, burning, scratches or abnormal stem wear.
 Check valve movement in the guide.
 Measure each valve stem O.D.

Service Limits: IN : 4.9mm replace if below
 EX: 4.9mm replace if below

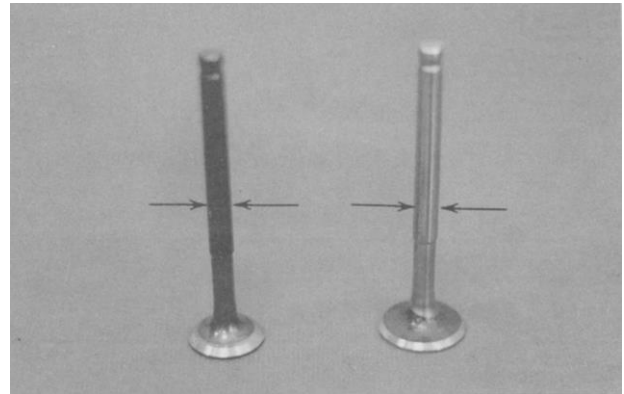

CYLINDER HEAD ASSEMBLY

- * When assembling, a valve spring compressor must be used.
- Install the cotters with the pointed ends facing down from the upper side of the cylinder head.

Special

Valve Spring Compressor
 Valve Spring Compressor Attachment

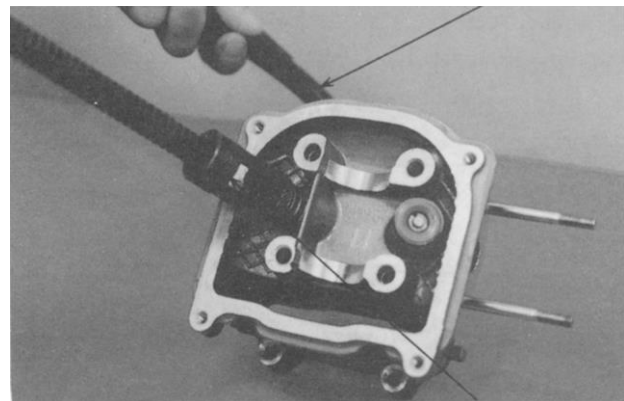

Valve Spring Compressor

Valve Spring Compressor Attachment

Tap the valve stems gently with a plastic hammer for 2~3 times to firmly seat the cotters.

- * Be careful not to damage the valves.

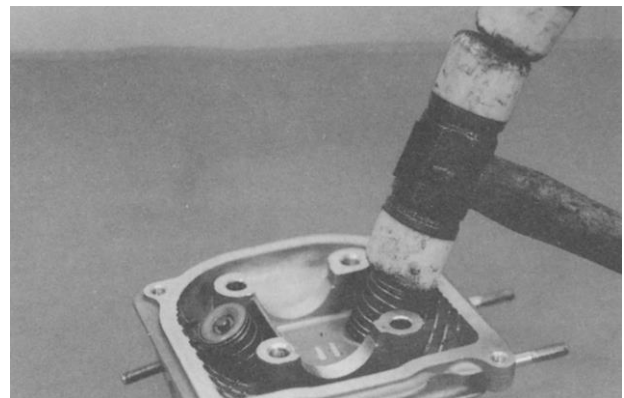

CYLINDER HEAD INSTALLATION

Install the dowel pins and a new cylinder head gasket.
 Install the cam chain guide.

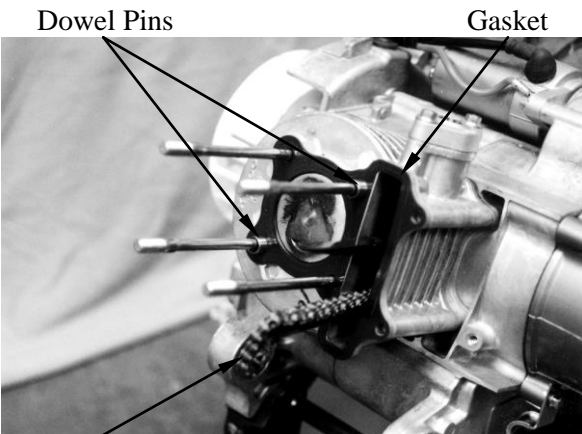

Cam Chain Guide

7. CYLINDER HEAD/VALVES

Install the cylinder head.

Cylinder Head

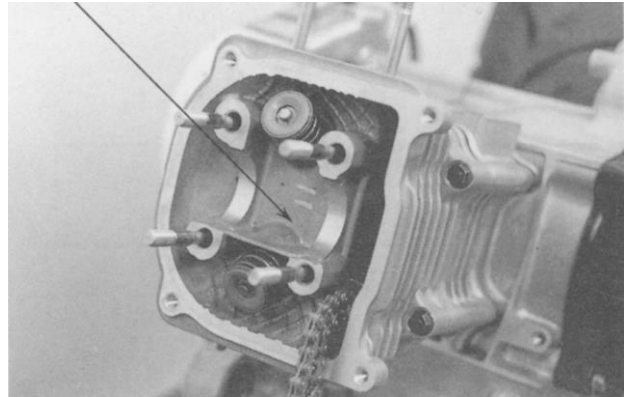

CAMSHAFT HOLDER ASSEMBLY

First assemble the camshaft holder.
Install the intake and exhaust valve rocker arms and rocker arm shafts.

- * • When installing the rocker arm shaft, align the shaft front end with the bolt hole of the camshaft holder.

Camshaft Holder

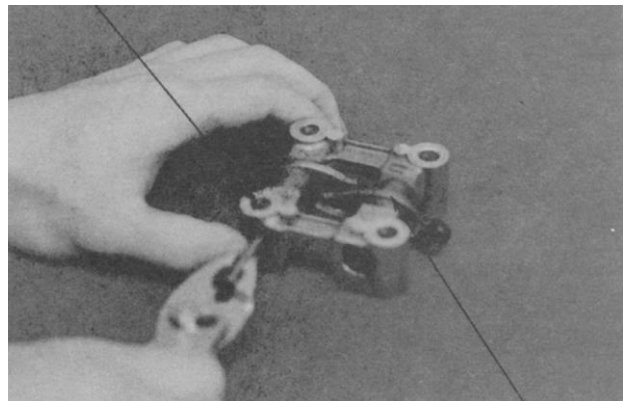

CAMSHAFT INSTALLATION

Turn the flywheel so that the “T” mark on the flywheel aligns with the index mark on the crankcase.

Keep the round hole on the camshaft gear facing up and align the punch marks on the camshaft gear with the cylinder head surface (Position the intake and exhaust cam lobes down.) and install the camshaft onto the cylinder head.

Install the cam chain over the camshaft gear.

Valve Rocker Arm
Camshaft Gear

Cam Chain

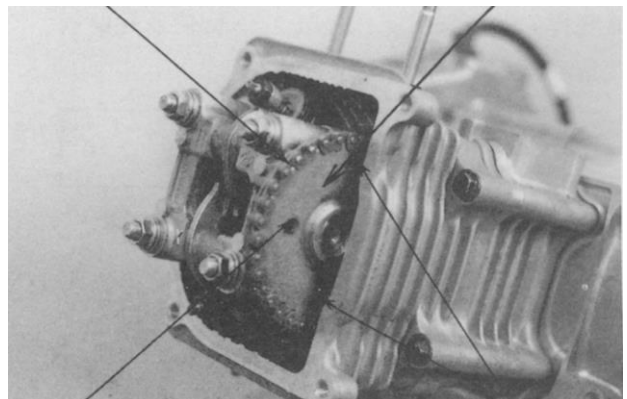

Round Hole

Punch Marks

Dowel Pins

Install the dowel pins.

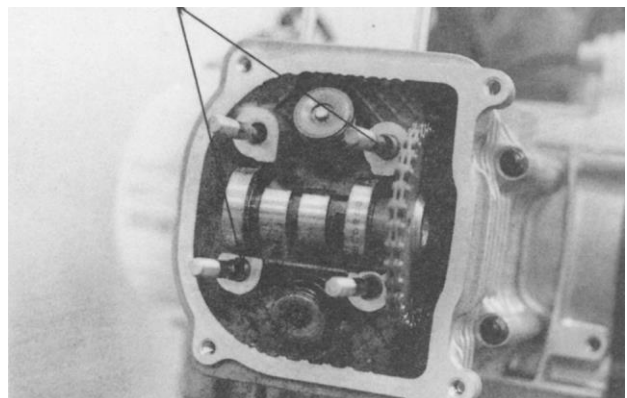

7. CYLINDER HEAD/VALVES

Install the camshaft holder, washers and nuts on the cylinder head.
Tighten the four cylinder head nuts and two bolts.

Torque: Cylinder head nut: 1.8~2.2kgf-m

- * • Apply engine oil to the threads of the cylinder head nuts.
- Diagonally tighten the cylinder head nuts in 2~3 times.

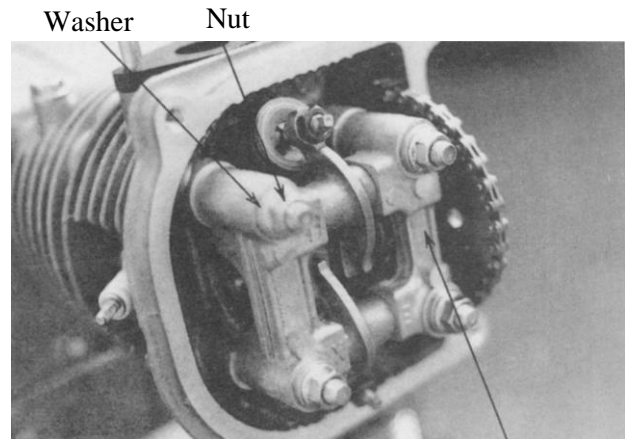

Washer Nut
Camshaft Holder

CAM CHAIN TENSIONER INSTALLATION

First install a new cam chain tensioner gasket.
Install the tensioner using the two bolts.
Install the tensioner spring.
Install the O-ring and sealing bolt.

- * When installing the tensioner, release the lock pawl and push the push rod all the way in.

Torque: 0.45~0.6kgf-m

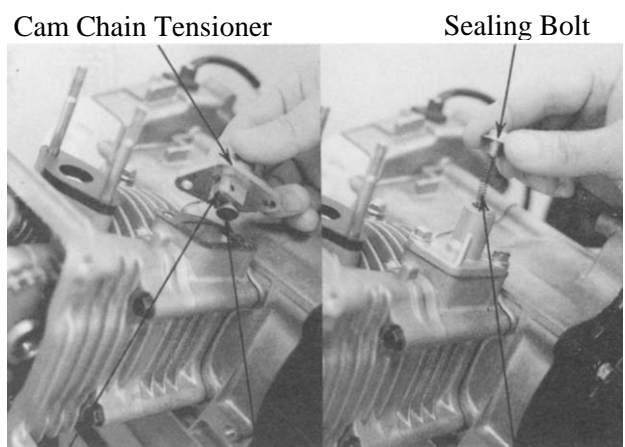

Cam Chain Tensioner Sealing Bolt
Lock Pawl Push Rod Spring

Adjust the valve clearance. (⇒3-5)
Install a new cylinder head cover O-ring and install the cylinder head cover.

- * Be sure to install the O-ring into the groove properly.

Install and tighten the cylinder head cover bolts.

Torque: 0.8~1.2kgf-m

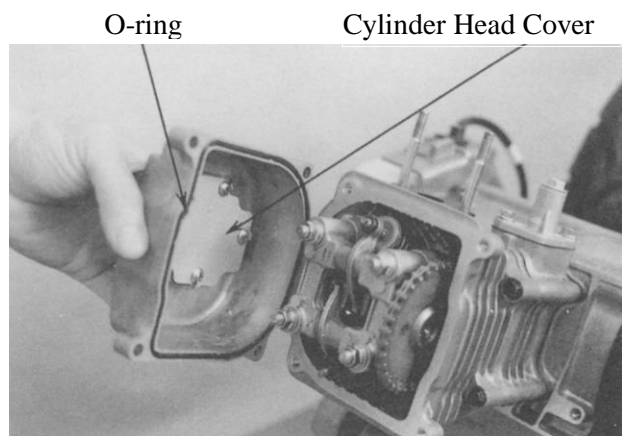

O-ring Cylinder Head Cover

8. CYLINDER/PISTON

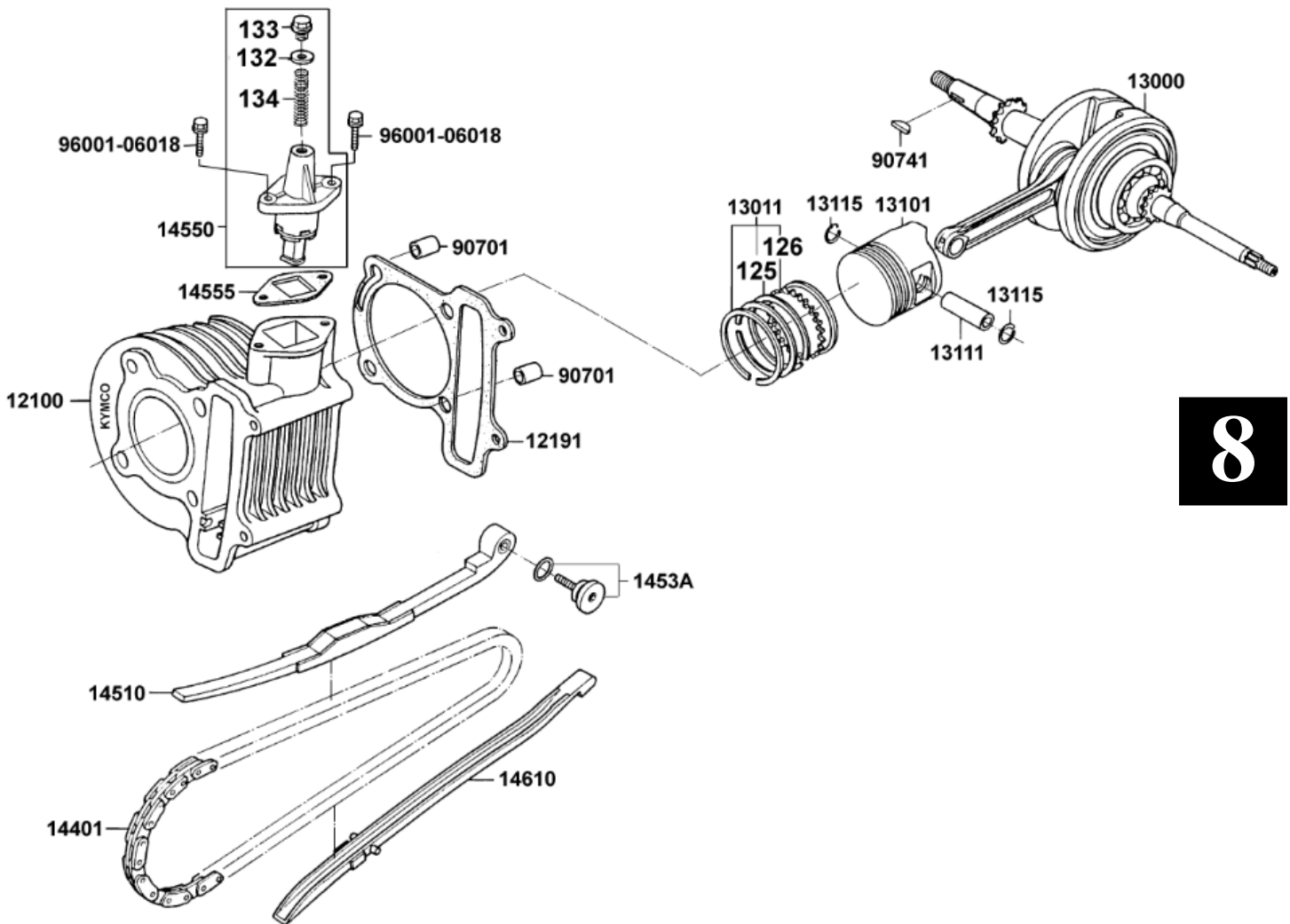

8

8. CYLINDER/PISTON

SERVICE INFORMATION.....8-1	PISTON REMOVAL.....8-2
TROUBLESHOOTING.....8-1	PISTON INSTALLATION.....8-6
CYLINDER REMOVAL.....8-2	CYLINDER INSTALLATION.....8-6

SERVICE INFORMATION

GENERAL INSTRUCTIONS

- The cylinder and piston can be serviced with the engine installed in the frame.
- After disassembly, clean the removed parts and dry them with compressed air before inspection.

SPECIFICATIONS

Item		Standard (mm)	Service Limit (mm)	
Cylinder	I.D.	39.00	39.10	
	Warpage	—	0.05	
	Cylindricity	—	0.05	
	True roundness	—	0.05	
Piston, piston ring	Ring-to-groove clearance	Top	0.015-0.050	0.09
		Second	0.015-0.050	0.09
	Ring end gap	Top	0.08-0.20	0.45
		Second	0.05-0.20	0.45
		Oil side rail	0.20-0.70	—
	Piston O.D.		38.99-38.975	38.975
	Piston O.D. measuring		9mm from bottom of skirt	—
	Piston-to-cylinder clearance		0.010-0.040	0.1
Piston pin hole I.D.		13.002-13.008	13.004	
Piston pin O.D		12.994-13.000	12.96	
Piston-to-piston pin clearance		0.002-0.014	—	
Connecting rod small end I.D. bore		13.016-13.034	13.06	

TROUBLESHOOTING

- When hard starting or poor performance at low speed occurs, check the crankcase breather for white smoke. If white smoke is found, it means that the piston rings are worn, stuck or broken.

Compression too low or uneven compression

- Worn, stuck or broken piston rings
- Worn or damaged cylinder and piston

Compression too high

- Excessive carbon build-up in combustion chamber or on piston head

Excessive smoke from exhaust muffler

- Worn or damaged piston rings
- Worn or damaged cylinder and piston

Abnormal noisy piston

- Worn cylinder, piston and piston rings
- Worn piston pin hole and piston pin

8. CYLINDER/PISTON

AGILITY 50

CYLINDER REMOVAL

Remove the cylinder head. (⇒7-6)
 Remove the cam chain guide.
 Remove the cylinder.

Cylinder



Remove the cylinder gasket and dowel pins.
 Clean any gasket material from the cylinder surface.

Dowel Pins



Gasket

Piston Pin

PISTON REMOVAL

Remove the piston pin clip.

* Place a clean shop towel in the crankcase to keep the piston pin clip from falling into the crankcase.

Press the piston pin out of the piston and remove the piston.



Piston Rings

Piston

8. CYLINDER/PISTON

Inspect the piston, piston pin and piston rings.
Remove the piston rings.

- * Take care not to damage or break the piston rings during removal.

Clean carbon deposits from the piston ring grooves.



Install the piston rings onto the piston and measure the piston ring-to-groove clearance.

Service Limits: **Top:** 0.09mm replace if over
2nd: 0.09mm replace if over



Remove the piston rings and insert each piston ring into the cylinder bottom.

- * Use the piston head to push each piston ring into the cylinder.

Measure the piston ring end gap.

Service Limit: 0.45mm replace if over

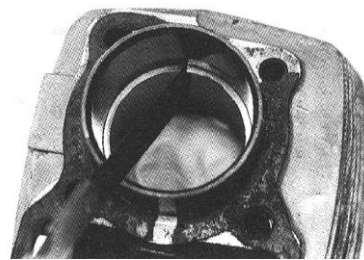

Measure the piston pin hole I.D.

Service Limit: 13.004mm replace if below

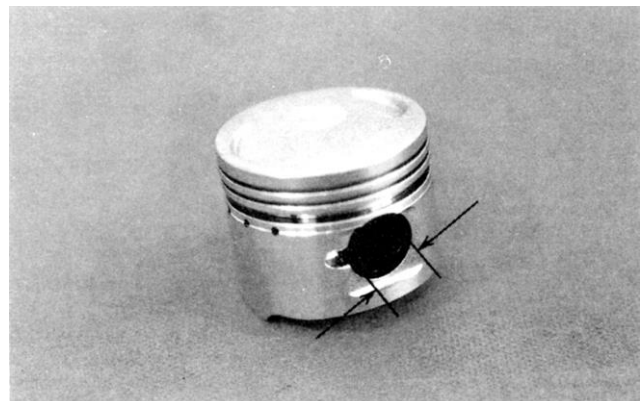

8. CYLINDER/PISTON

Measure the piston pin O.D.

Service Limit: 12.96mm replace if below

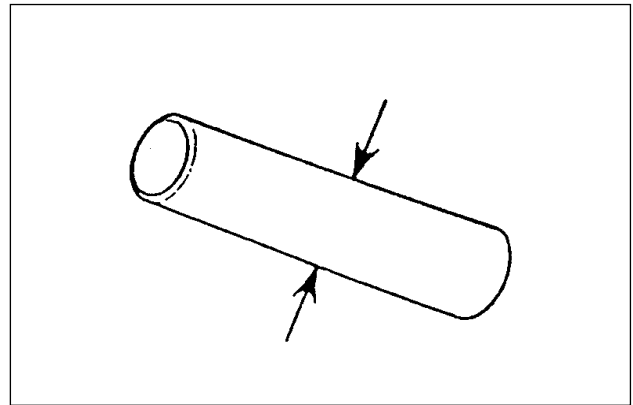

Measure the piston O.D.

* Take measurement at 9mm from the bottom and 90° to the piston pin hole.

Service Limit: 38.9mm replace if below
Measure the piston-to-piston pin clearance.

Service Limit: 0.02mm replace if over

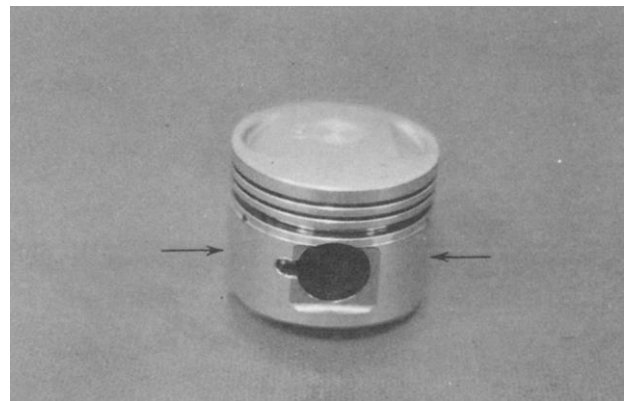

CYLINDER INSPECTION

Inspect the cylinder bore for wear or damage. Measure the cylinder I.D. at three levels of top, middle and bottom at 90° to the piston pin (in both X and Y directions).

Service Limit: 39.10mm repair or replace if over

Measure the cylinder-to-piston clearance.

Service Limit: 0.1mm repair or replace if over

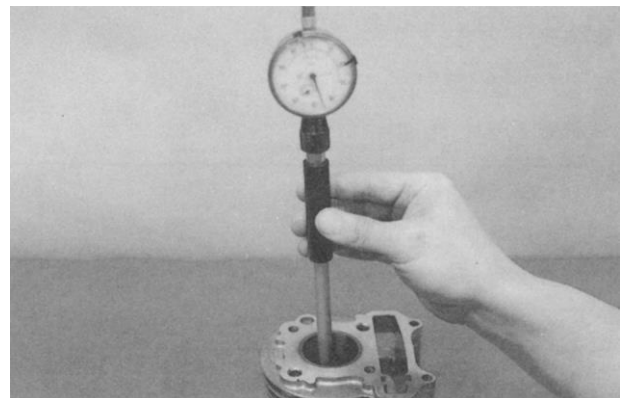

The true roundness is the difference between the values measured in X and Y directions. The cylindricity (difference between the values measured at the three levels) is subject to the maximum value calculated.

Service Limits:

True Roundness: 0.05mm repair or replace if over

Cylindricity: 0.05mm repair or replace if over

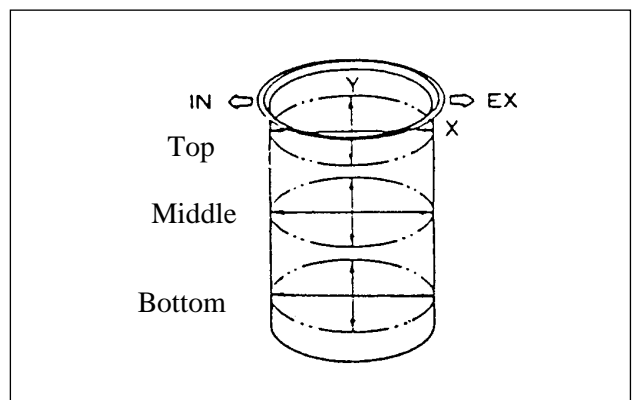

8. CYLINDER/PISTON

Inspect the top of the cylinder for warpage.
Service Limit: 0.05mm repair or replace if over

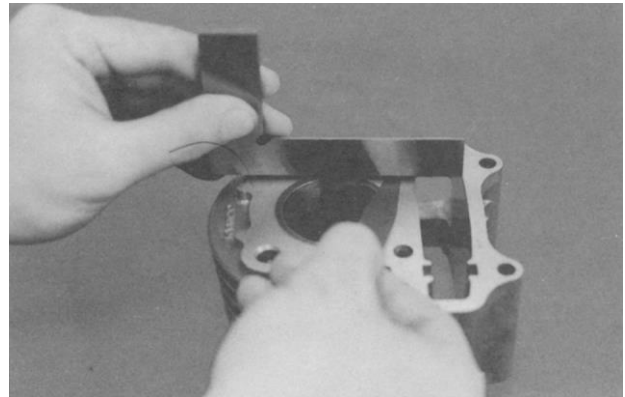

Measure the connecting rod small end I.D.
Service Limit: 13.06mm replace if over

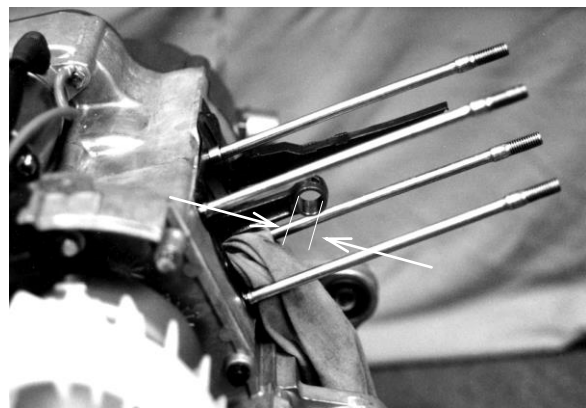

PISTON RING INSTALLATION

Install the piston rings onto the piston.
 Apply engine oil to each piston ring.

- *
- Be careful not to damage or break the piston and piston rings.
 - All rings should be installed with the markings facing up.
 - After installing the rings, they should rotate freely without sticking.

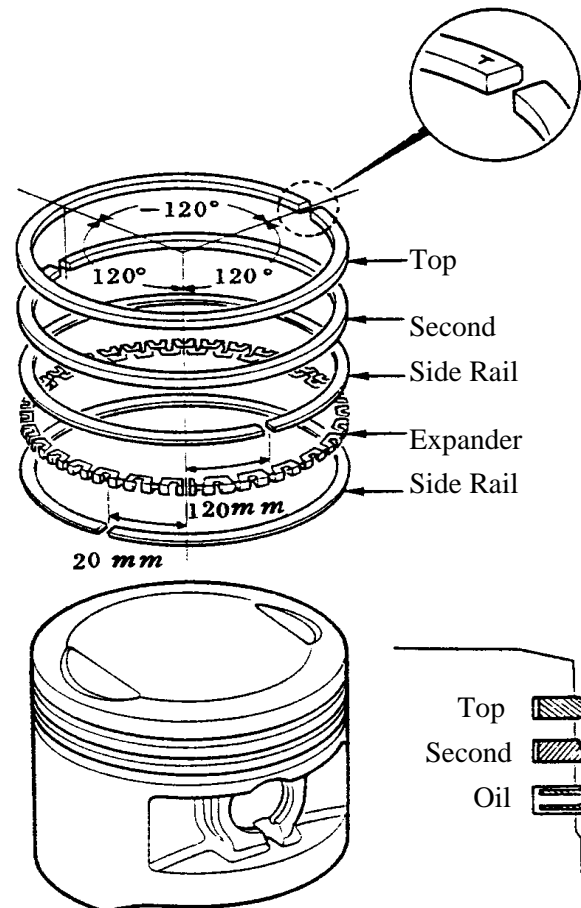

8. CYLINDER/PISTON

PISTON INSTALLATION

Remove any gasket material from the crankcase surface.

- * Be careful not to drop foreign matters into the crankcase.

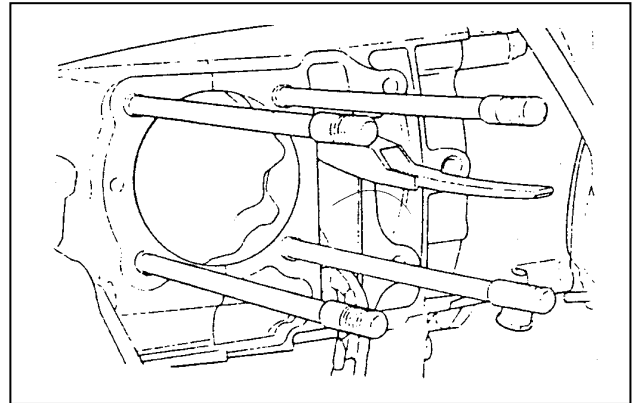

Install the piston, piston pin and a new piston pin clip.

- *
 - Position the piston “IN” mark on the intake valve side.
 - Place a clean shop towel in the crankcase to keep the piston pin clip from falling into the crankcase.

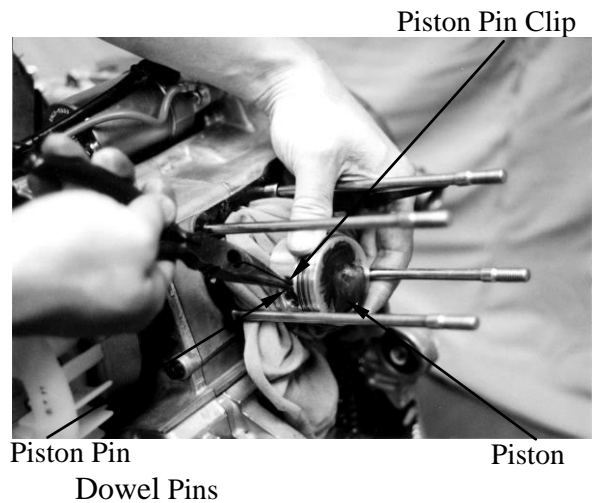

CYLINDER INSTALLATION

Install the dowel pins and a new cylinder gasket on the crankcase.



Coat the cylinder bore, piston and piston rings with clean engine oil.
Carefully lower the cylinder over the piston by compressing the piston rings.

- *
 - Be careful not to damage or break the piston rings.
 - Do not align the ring end gaps with the intake/exhaust valve and piston pin.



8. CYLINDER/PISTON

Install the cam chain guide.

- *

Insert the tab on the cam chain guide into the cylinder groove.

Install the cylinder head. (⇒7-8)

Loosely install the cylinder base bolts.



Cam Chain Guide

Tighten the cylinder base bolts.

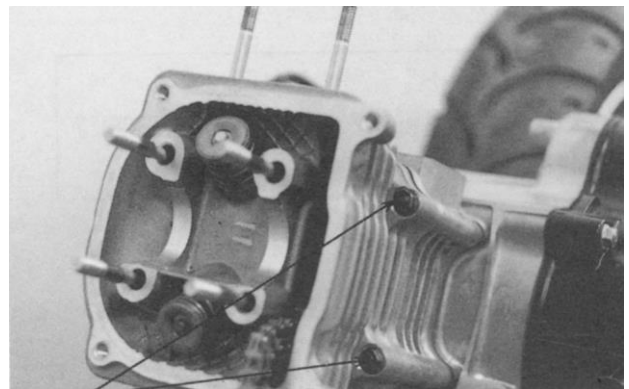

Cylinder Base Bolts

9. DRIVE AND DRIVEN PULLEYS/ KICK STARTER

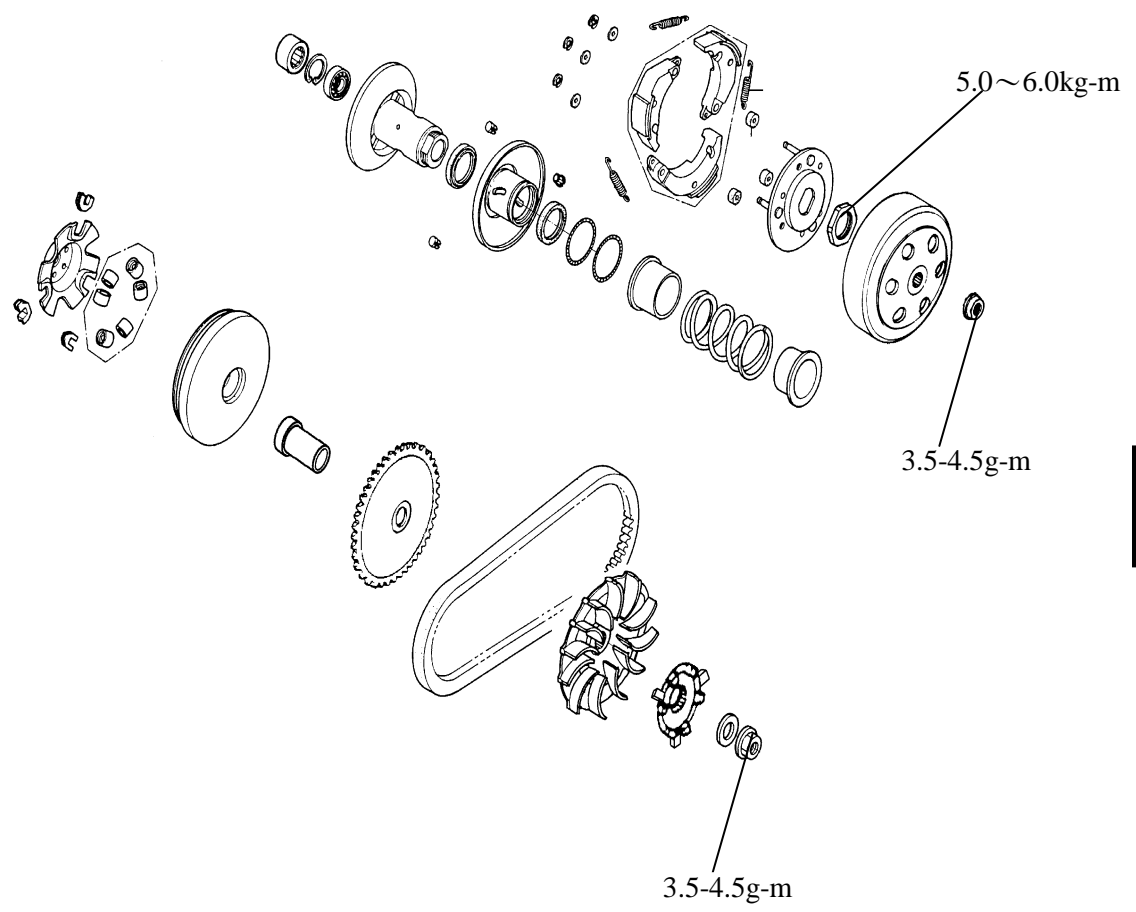

9

9. DRIVE AND DRIVEN PULLEYS/ KICK STARTER

LEFT CRANKCASE COVER

REMOVAL

Loosen the drive belt air tube band screw.
Remove the eight left crankcase cover bolts and left crankcase cover.
Remove the seal rubber and dowel pins.
Inspect the seal rubber for damage or deterioration.

* Use specified genuine parts for replacement.



Left Crankcase Cover

Bolts

KICK STARTER

REMOVAL

Remove the kick lever from the kick starter spindle.
Remove the circlip and washer from the kick starter spindle.

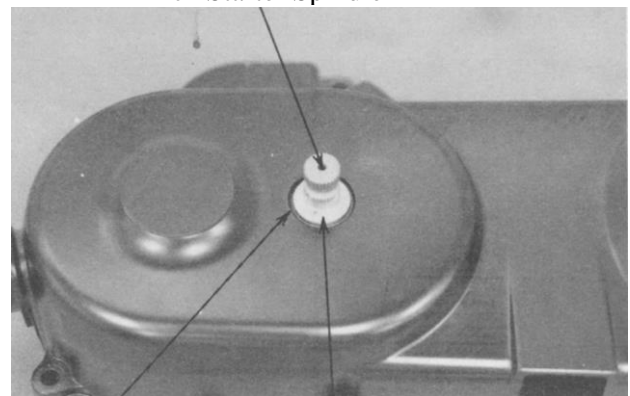

Kick Starter Spindle

Washer

Circlip

Gently turn the kick starter spindle to remove the starter driven gear together with the friction spring.

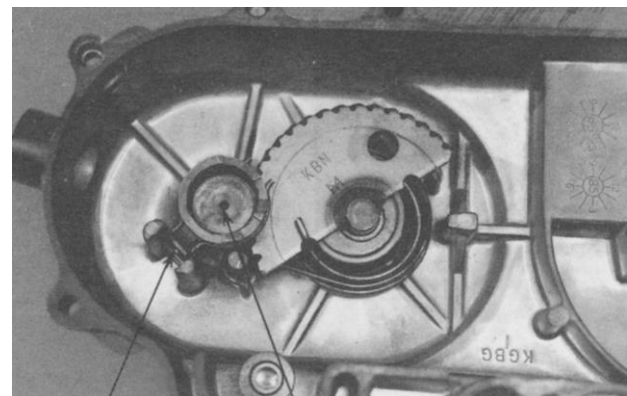

Friction Spring

Starter Driven Gear

Kick Starter Spindle

Remove the kick starter spindle and return spring from the left crankcase cover.
Remove the kick starter spindle bushings.

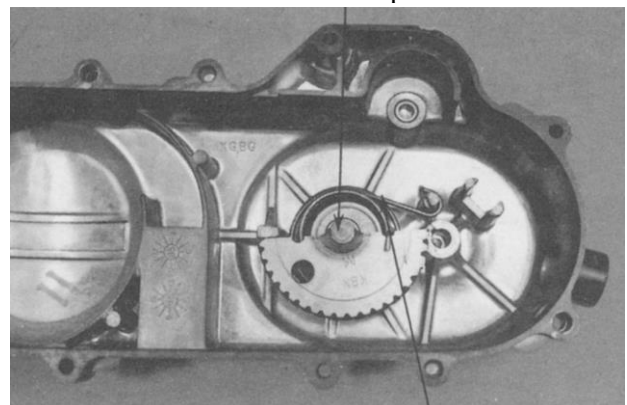

Return Spring

9. DRIVE AND DRIVEN PULLEYS/ KICK STARTER

INSPECTION

Inspect the kick starter spindle and gear for wear or damage.
Inspect the return spring for weakness or damage.
Inspect the kick starter spindle bushings for wear or damage.

Inspect the starter driven gear for wear or damage.
Inspect the friction spring for wear or damage.

Inspect the kick starter spindle and starter driven gear forcing parts for wear or damage.

INSTALLATION

Install the kick starter spindle bushings and return spring onto the left crankcase cover.

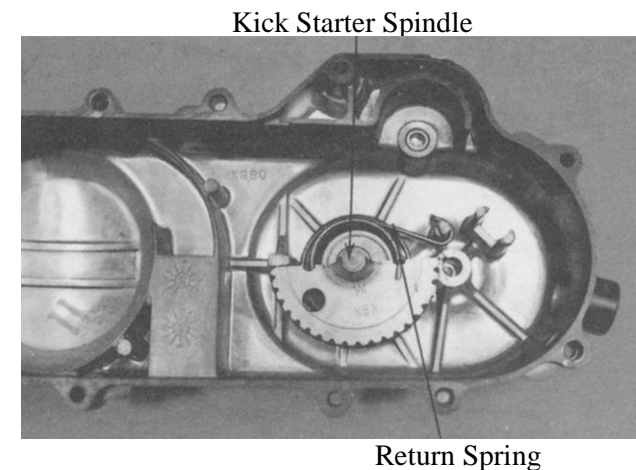
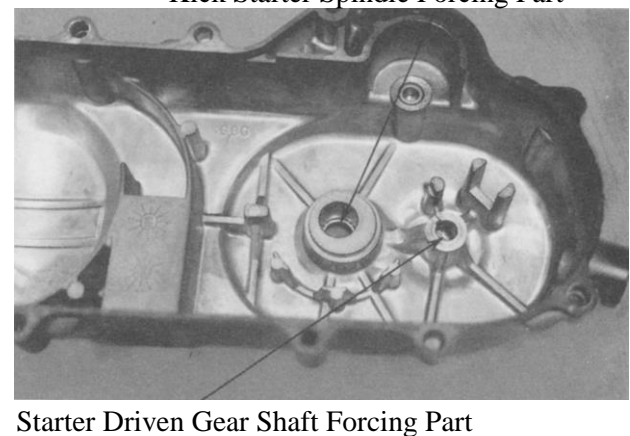
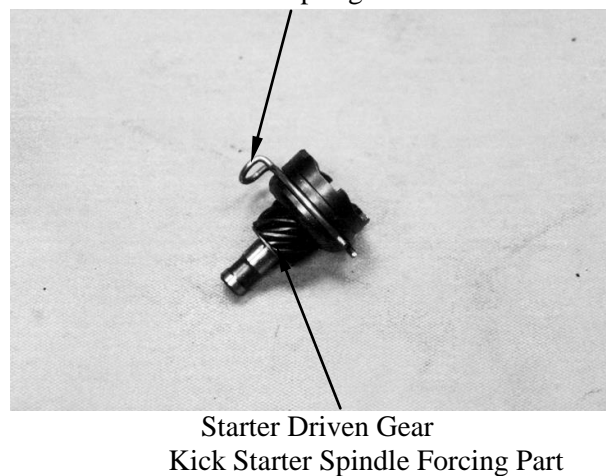
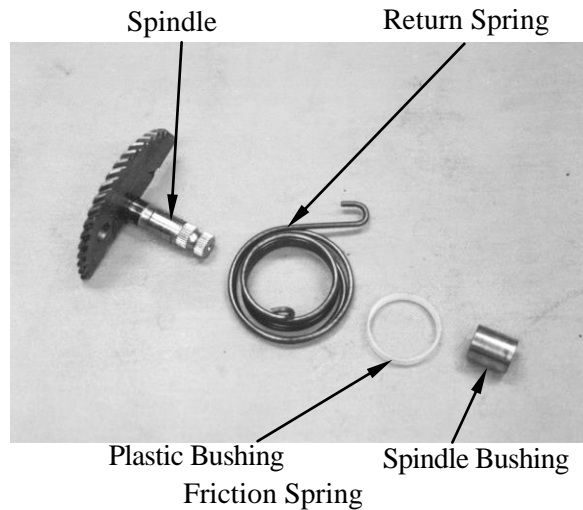

9. DRIVE AND DRIVEN PULLEYS/ KICK STARTER

Install the starter driven gear and friction spring onto the left crankcase cover as the figure shown.

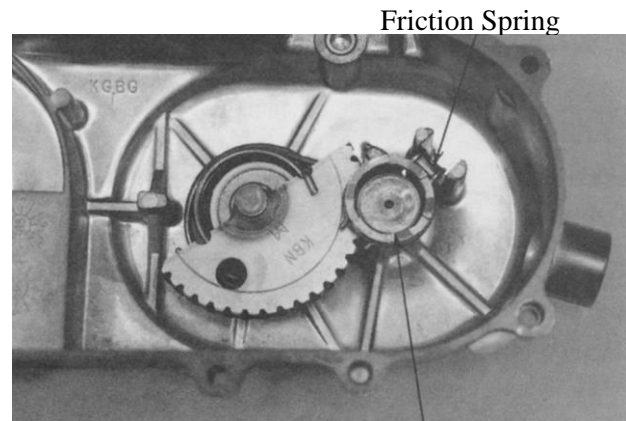

Starter Driven Gear

First install the washer and then install the circlip.
Install the kick lever.

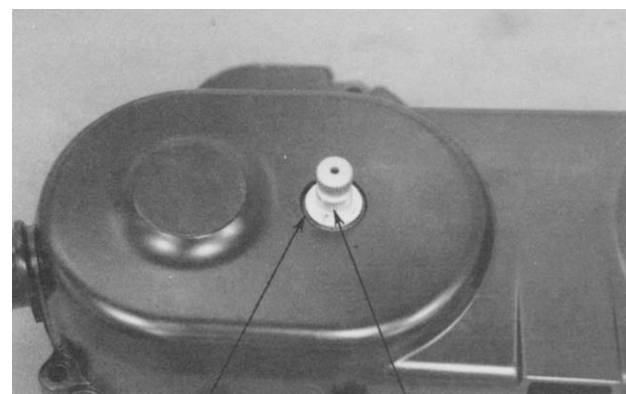

Washer

Circlip

LEFT CRANKCASE COVER INSTALLATION

First install the dowel pins.
Install the seal rubber.

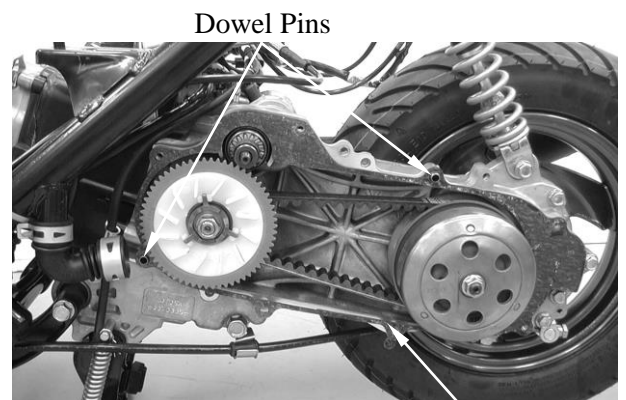

Dowel Pins

Seal Rubber

Install the left crankcase cover and tighten the eight left crankcase cover bolts diagonally.
Connect the drive belt air tube and tighten the tube band screw.
Install the rear brake cable clamp.



Left Crankcase Cover

Rear Brake Cable Clamp

9. DRIVE AND DRIVEN PULLEYS/ KICK STARTER

DRIVE BELT

REMOVAL

Remove the left crankcase cover.

INSPECTION

Check the drive belt for cracks, separation or abnormal or excessive wear.
Measure the drive belt width.

Service Limit: 16.5mm

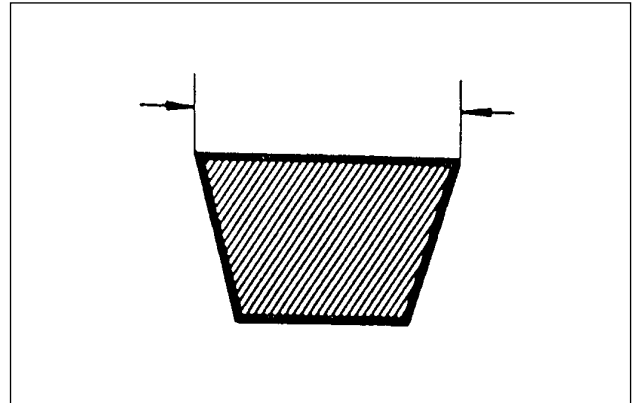

REPLACEMENT

Remove the eight left crankcase cover bolts and left crankcase cover. (⇒9-2)
Hold the clutch outer with an universal holder and remove the clutch outer nut.

 Special

Universal Holder

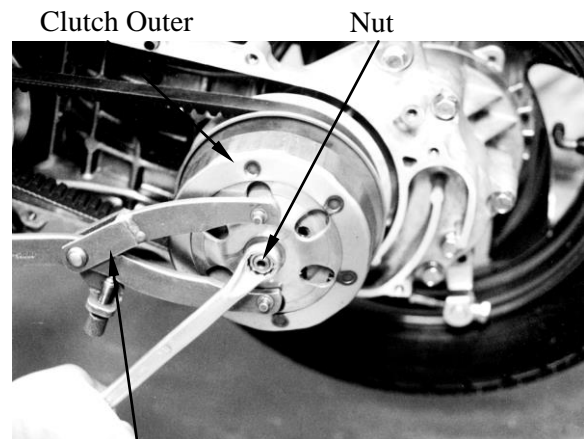

Hold the drive pulley using a holder and remove the drive face nut, starting ratchet and washer.
Remove the drive pulley face.

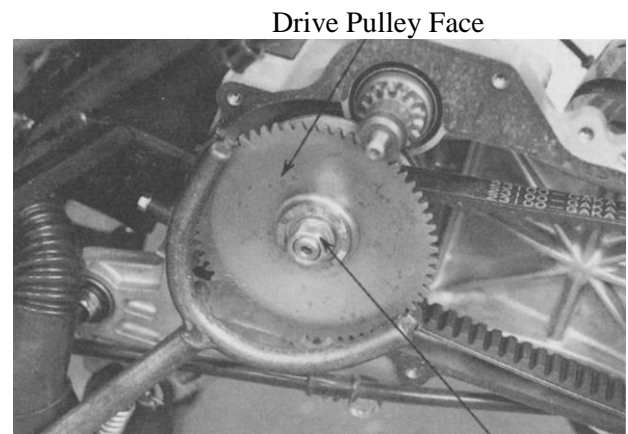

Remove the drive belt from the clutch/driven pulley.

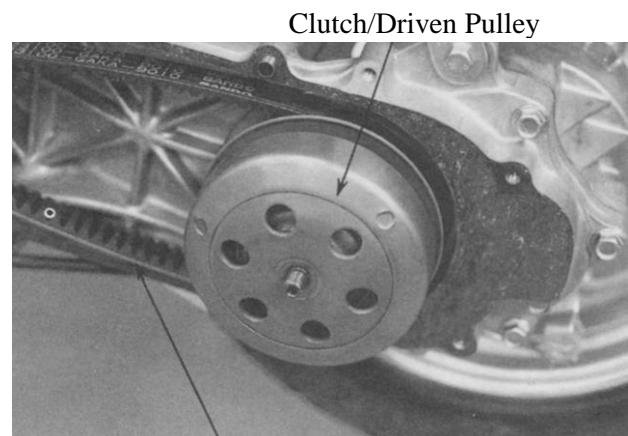

9. DRIVE AND DRIVEN PULLEYS/ KICK STARTER

INSTALLATION

Turn the driven pulley clockwise to widen the drive belt groove and lay a new drive belt on the driven pulley.

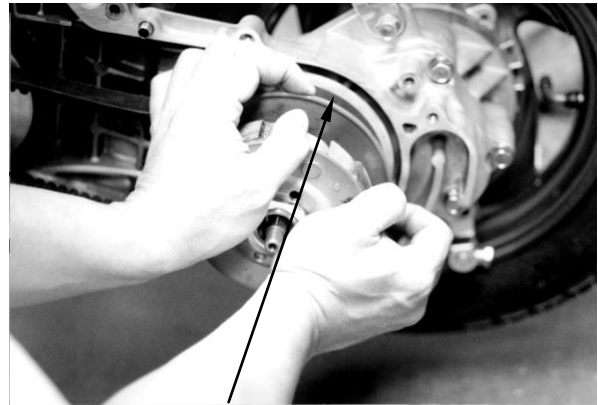

Drive Belt

Set the drive belt on the drive pulley face collar.
Install the drive pulley face, starting ratchet washer. Install and tighten the drive face nut.

* When installing, align the tooth space of the drive pulley face and starting ratchet with the crankshaft tooth and then tighten the nut.

Drive Face Nut Drive Pulley Face Drive Belt

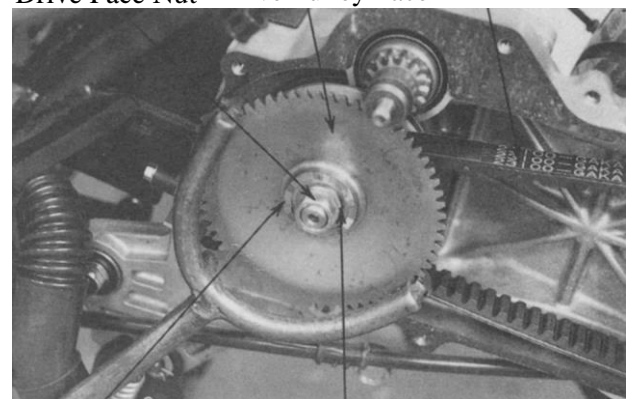

Starting Ratchet 10mmWasher

Drive Pulley Face Starting Ratchet

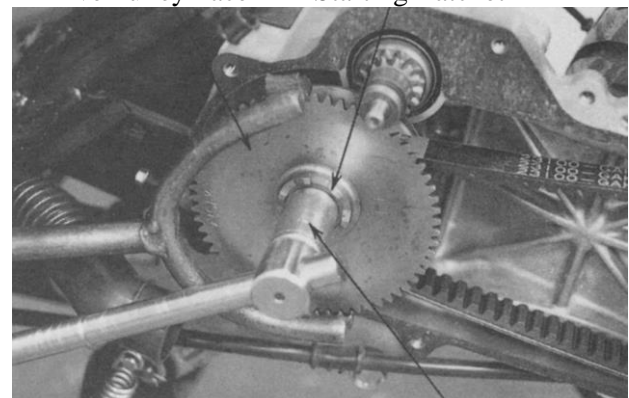

Drive Face Nut (10mm)

Movable Drive Face Assembly

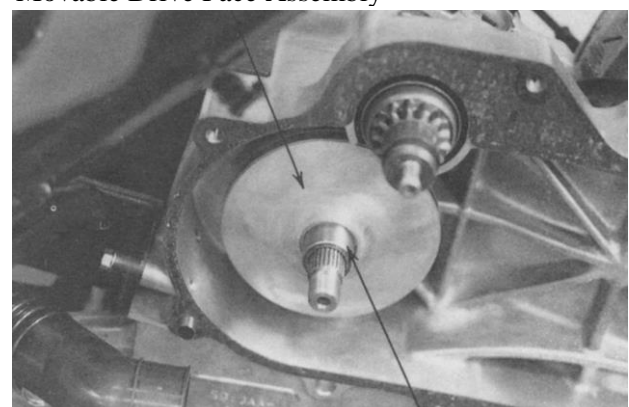

Drive Pulley Collar

DRIVE PULLEY

REMOVAL

Hold the drive pulley using a holder and remove the drive face nut, starting ratchet and washer.
Remove the drive pulley face.

DISASSEMBLY

Remove the movable drive face assembly and drive pulley collar from the crankshaft.

9. DRIVE AND DRIVEN PULLEYS/ KICK STARTER

Remove the ramp plate.

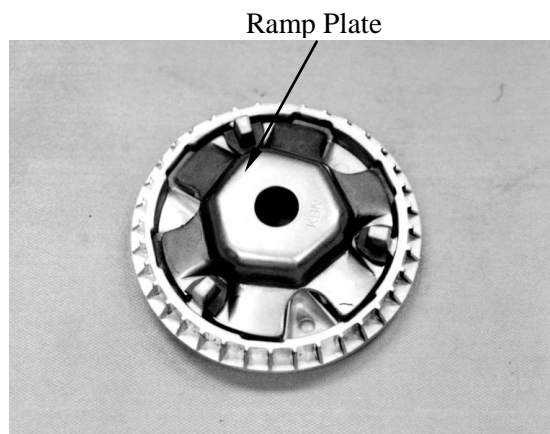

Remove the weight rollers.

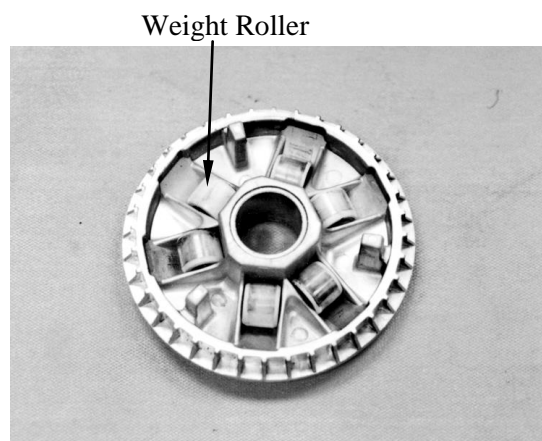

INSPECTION

Check each weight roller for wear or damage.
Measure each weight roller O.D.

Service Limit: 12.4mm replace if below

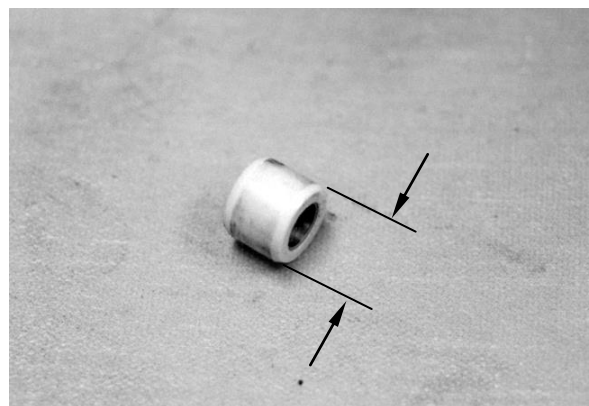

Check the drive pulley collar for wear or damage.
Measure the O.D. of the drive pulley collar sliding surface.

Service Limit: 19.97mm replace if below

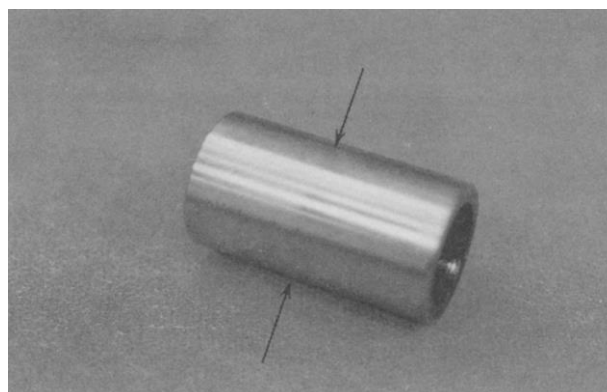

9. DRIVE AND DRIVEN PULLEYS/ KICK STARTER

INSTALLATION

Install the drive pulley collar and movable drive face onto the crankshaft.

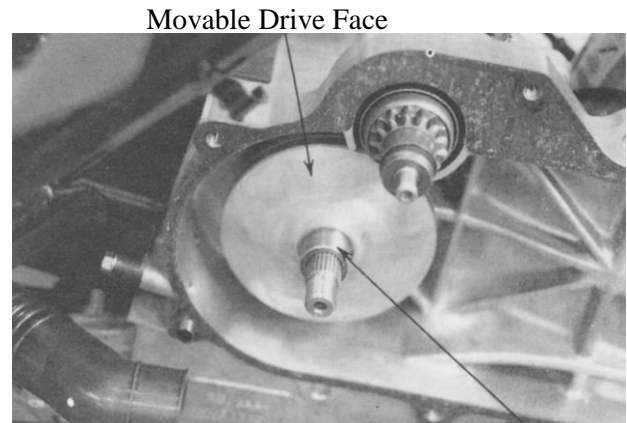

Drive Pulley Collar

Set the drive belt on the drive pulley collar. Install the drive pulley face and tighten the drive face nut. (⇒9-6)

Torque: 5.5~6.5kgf-m

* Do not get oil or grease on the drive belt or pulley faces.

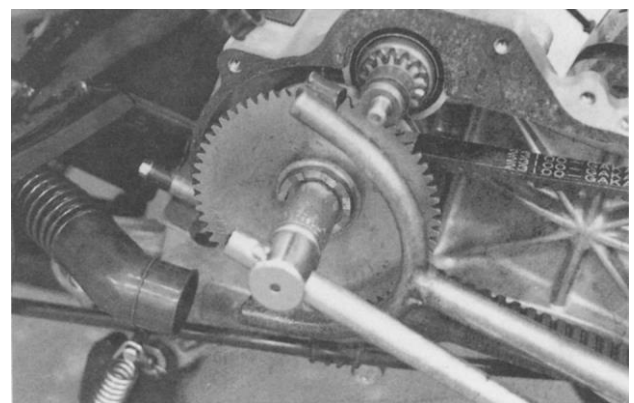

STARTER PINION

REMOVAL

Remove the left crankcase cover.
Remove the drive pulley.
Remove the starter pinion holder.
Remove the starter pinion.

INSPECTION

Inspect the starter pinion shaft forcing part for wear or damage.
Inspect the starter pinion for smooth operation.
Inspect the starter pinion and shaft for wear or damage.

INSTALLATION

Apply a small amount of grease to the starter pinion shaft and install it in the reverse order of removal.

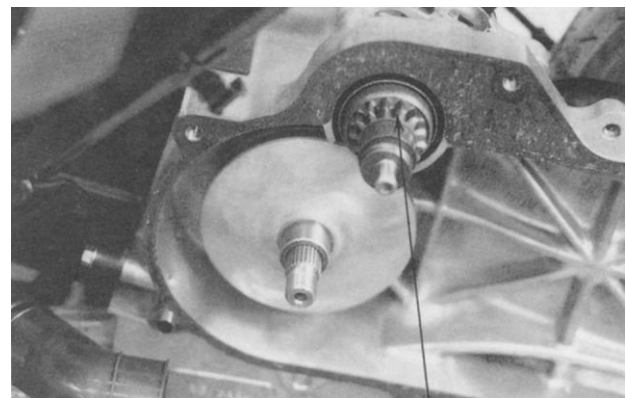

Starter Pinion
Starter Pinion Shaft



9. DRIVE AND DRIVEN PULLEYS/ KICK STARTER

CLUTCH/DRIVEN PULLEY

REMOVAL

Remove the drive pulley. (⇒9-6)
Hold the clutch outer with the universal holder and remove the clutch outer nut.
Remove the clutch outer.

Special

Universal Holder

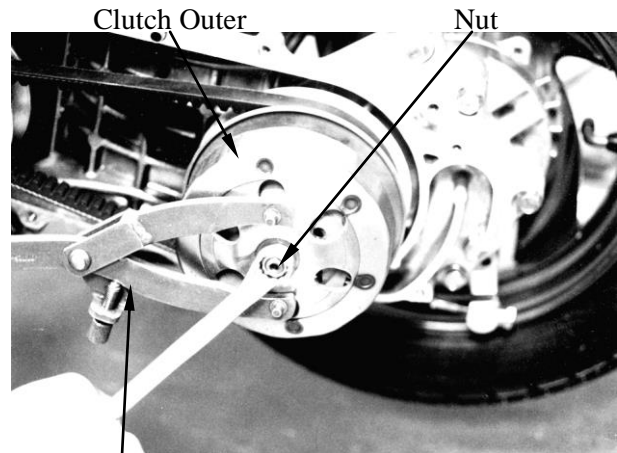

Universal Holder

Remove the clutch/driven pulley assembly
Remove the drive belt from the clutch/driven pulley assembly.

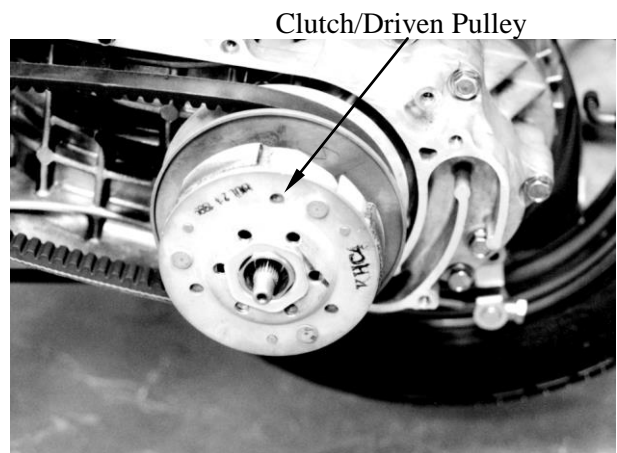

DISASSEMBLY

Hold the clutch/driven pulley assembly with the clutch spring compressor.
Set the clutch spring compressor in a vise and remove the 39mm clutch drive plate nut.
Loosen the clutch spring compressor and disassemble the driven pulley assembly.

Special

Clutch Spring Compressor

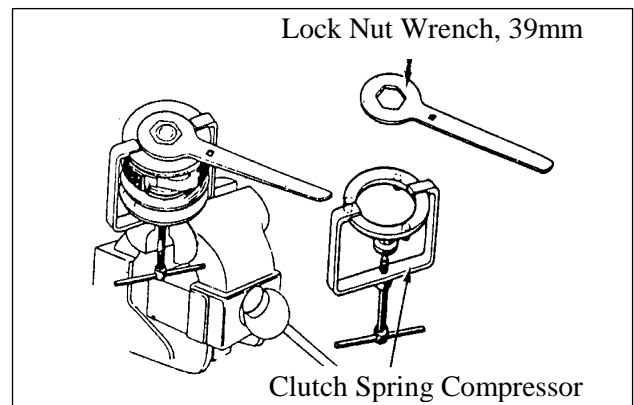

Remove the seal collar.

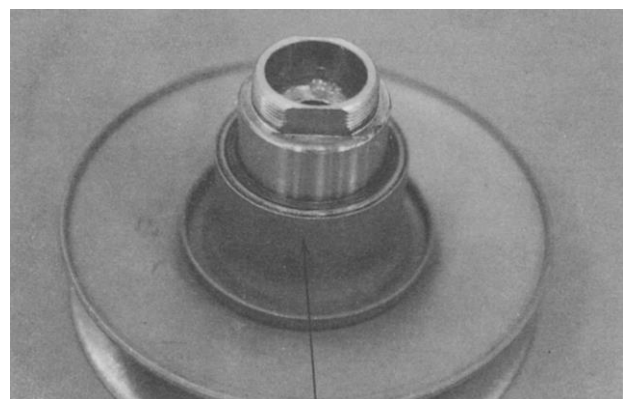

Seal Collar

9. DRIVE AND DRIVEN PULLEYS/ KICK STARTER

Pull out the guide roller pins and guide rollers.
Remove the movable driven face from the driven face.
Remove the O-rings and oil seal from the movable driven face.

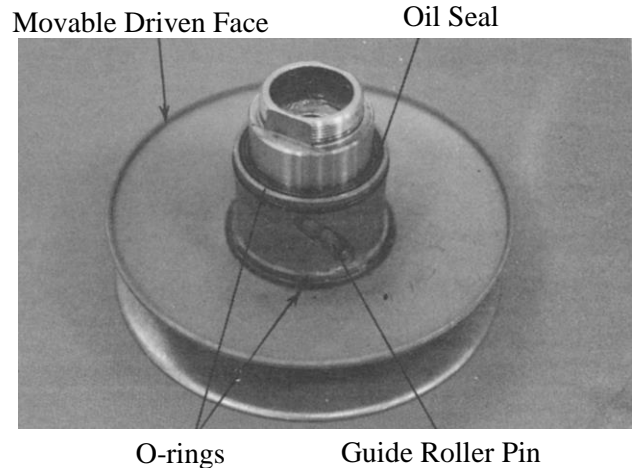

INSPECTION

Inspect the clutch outer for wear or damage.
Measure the clutch outer I.D.

Service Limit: 107.5mm replace if over

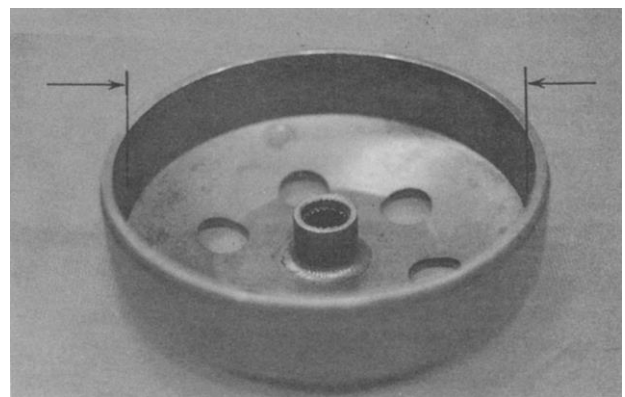

Check the clutch shoes for wear or damage.
Measure the clutch lining thickness.

Service Limit: 2.0mm replace if below

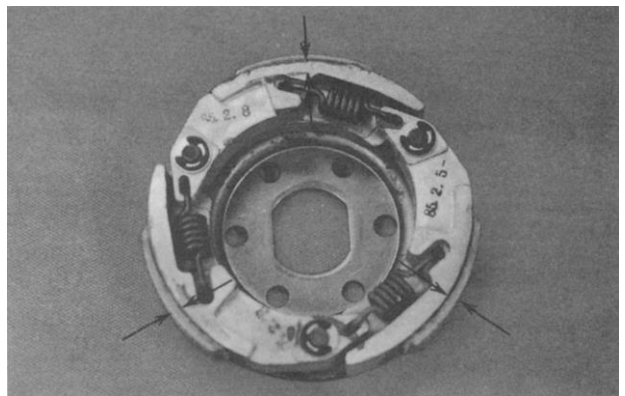

Measure the driven face spring free length.

Service Limit: 92.8mm replace if below

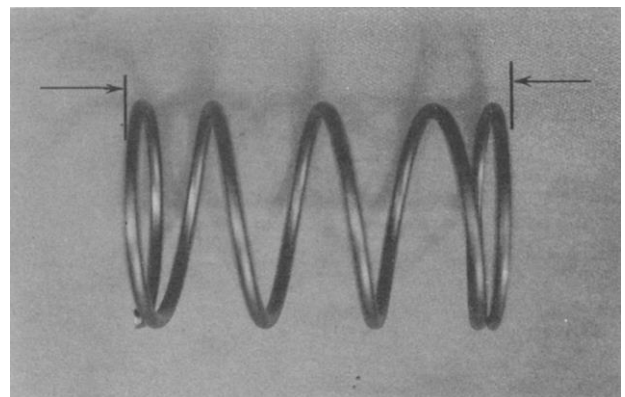

9. DRIVE AND DRIVEN PULLEYS/ KICK STARTER

Check the driven face for wear or damage.
Measure the driven face O.D.

Service Limit: 33.94mm replace if below

Check the movable driven face for wear or damage.

Measure the movable driven face I.D.

Service Limit: 34.06mm replace if over

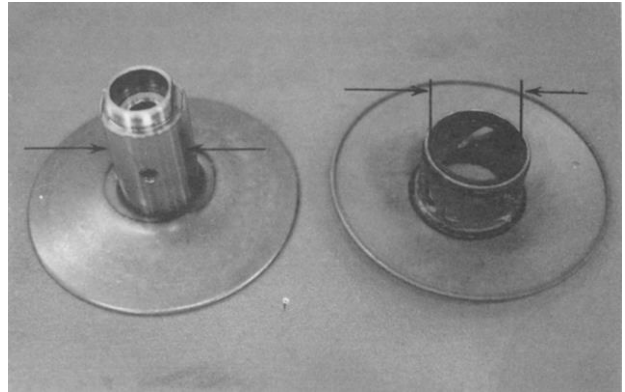

DRIVEN PULLEY FACE BEARING REPLACEMENT

Drive the inner needle bearing out of the
driven pulley face.

Discard the removed bearing and replace with
a new one.

Inner Bearing

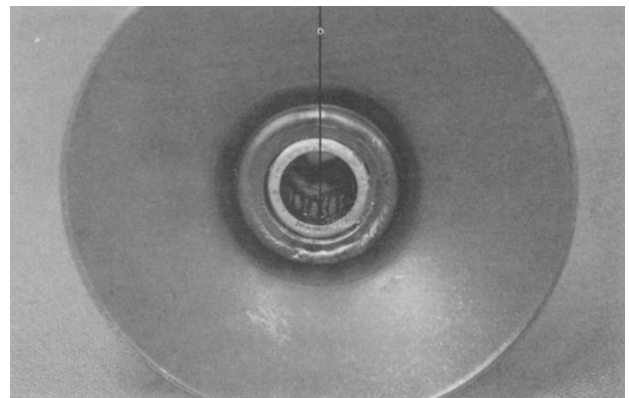

Remove the snap ring and drive the outer
bearing out of the driven face.

Snap Ring

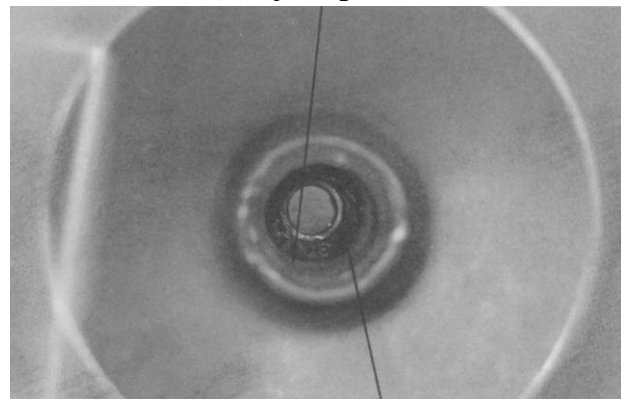

Outer Bearing
Bearing Remover

Apply grease to the outer bearing.
Drive a new outer bearing into the driven face
with the sealed end facing up.
Seat the snap ring in its groove.

* Pack all bearing cavities with 5.0~5.6g
grease.
Specified grease: Heat resistance 230°C

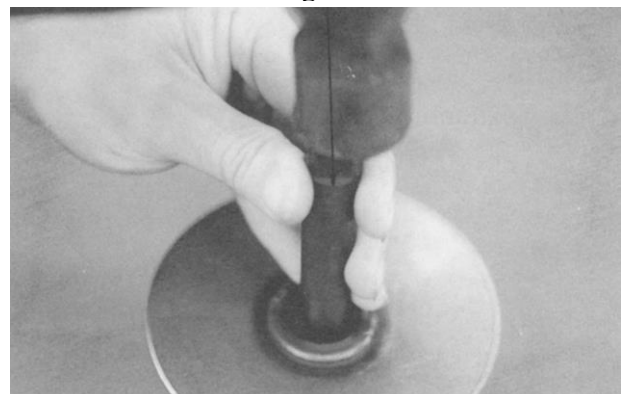

9. DRIVE AND DRIVEN PULLEYS/ KICK STARTER

Press a new needle bearing into the driven face.

ASSEMBLY

Install the movable driven face onto the driven face.
Install the O-rings, guide rollers and guide roller pins.
Install the a new oil seal.

Install the seal collar.

Set the driven pulley assembly, driven face spring and clutch assembly onto the clutch spring compressor.
Compress the clutch spring compressor and install the 39mm drive plate nut.
Set the clutch spring compressor in a vise and tighten the drive plate nut to the specified torque.

Torque: 5.0~6.0kgf-m

Special

Clutch Spring Compressor

Driver Handle

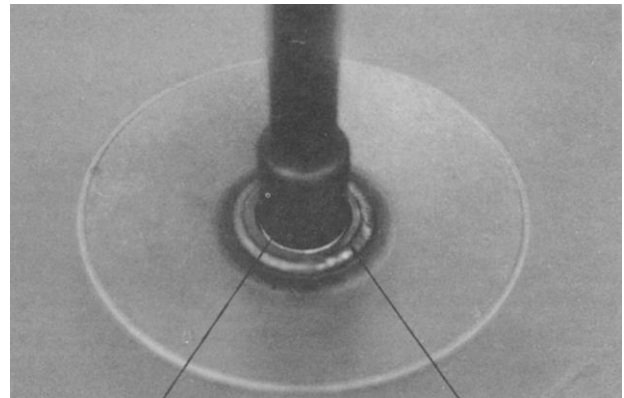

Outer Driver, 24x26mm
Movable Driven Face

Pilot, 17mm
Oil Seal

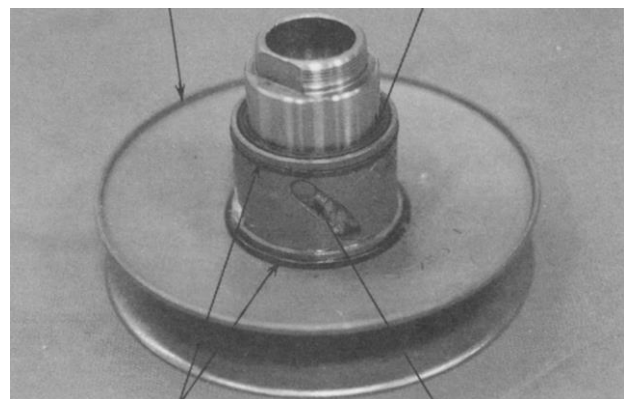

O-rings

Guide Roller Pin

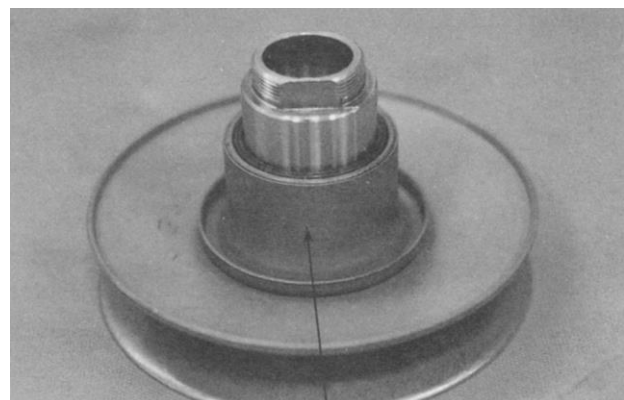

Seal Collar
Lock Nut Wrench, 39mm

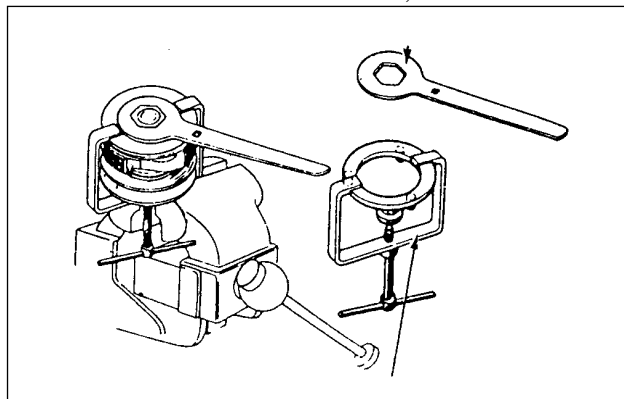

Clutch Spring Compressor

9. DRIVE AND DRIVEN PULLEYS/ KICK STARTER

INSTALLATION

Lay the drive belt on the driven pulley and install the clutch/driven pulley onto the drive shaft.

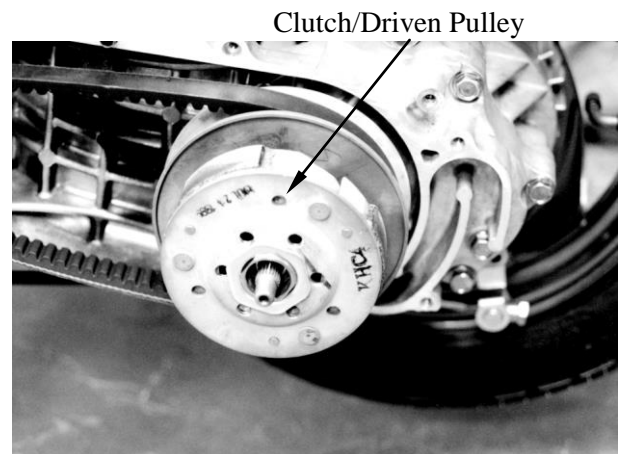

Install the clutch outer.
Hold the clutch outer with the universal holder.
Install and tighten the 10mm clutch outer nut.
Torque: 3.5~4.5kgf-m
Install the left crankcase cover. (⇒9-4)

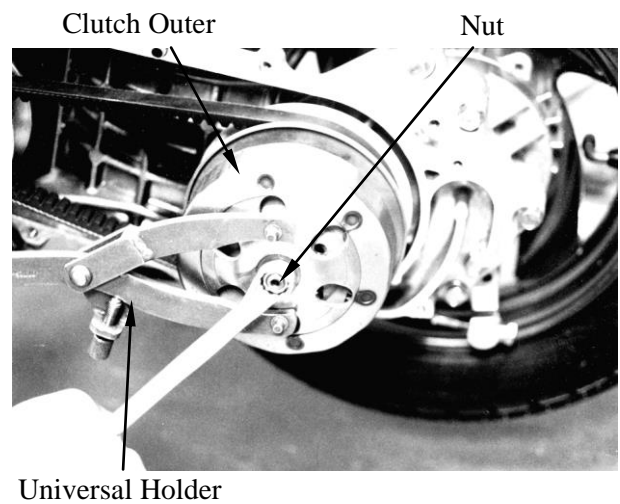

10. FINAL REDUCTION

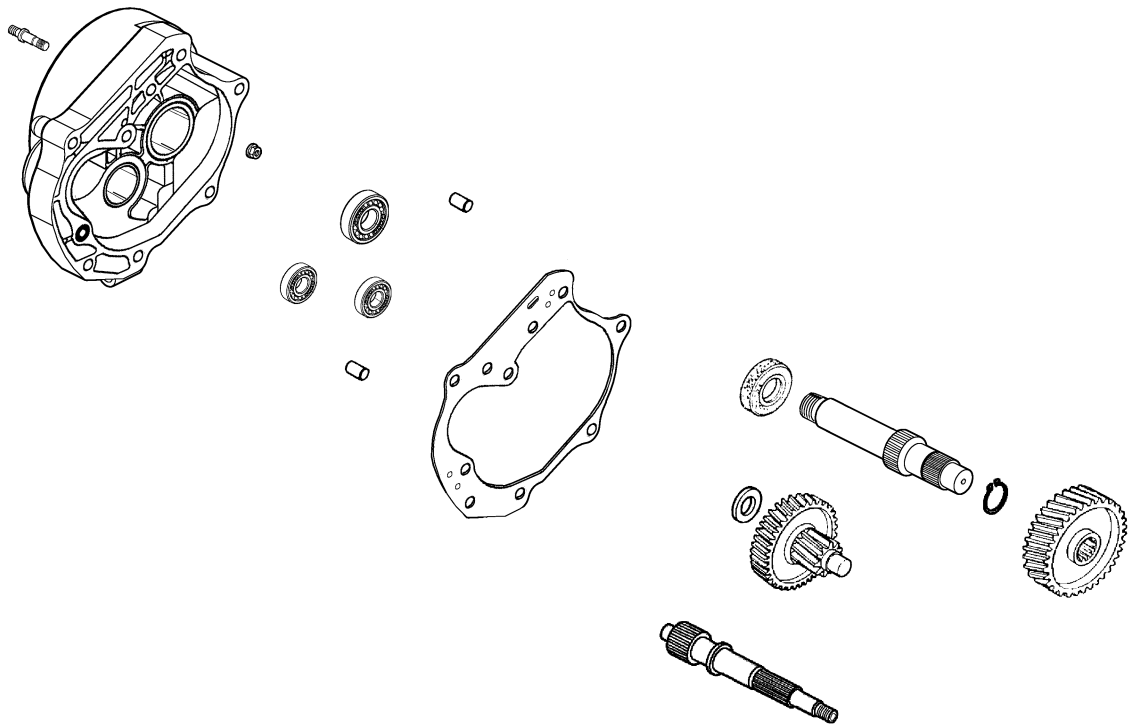

10. FINAL REDUCTION

SERVICE INFORMATION	10-1	FINAL REDUCTION INSPECTION	10-2
TROUBLESHOOTING	10-1	BEARING REPLACEMENT	10-3
FINAL REDUCTION DISASSEMBLY	10-2	FINAL REDUCTION ASSEMBLY	10-4

SERVICE INFORMATION

SPECIFICATIONS

Specified Oil: GEAR OIL SAE 90#

Oil Capacity: At disassembly : 0.18 liter
 At change : 0.15 liter

SPECIAL TOOLS

Bearing puller, 10,12,15,18mm

TROUBLESHOOTING

Engine starts but motorcycle won't move

- Damaged transmission
- Seized or burnt transmission
- Faulty drive belt
- Faulty clutch

Abnormal noise

- Worn, seized or chipped gears
- Worn bearing

Oil leaks

- Oil level too high
- Worn or damaged oil seal

10. FINAL REDUCTION

FINAL REDUCTION DISASSEMBLY

- Remove the rear brake cable. (⇒13-3)
- Remove the rear wheel. (⇒13-2)
- Remove the left crankcase cover. (⇒9-2)
- Remove the clutch/driven pulley. (⇒9-10)
- Drain the transmission gear oil into a clean container.
- Remove the transmission case cover attaching bolts.
- Remove the transmission case cover.
- Remove the gasket and dowel pins.

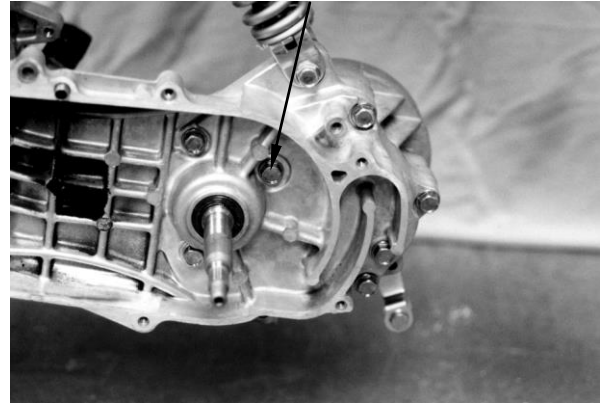

Remove the final gear and countershaft.

Drive Shaft

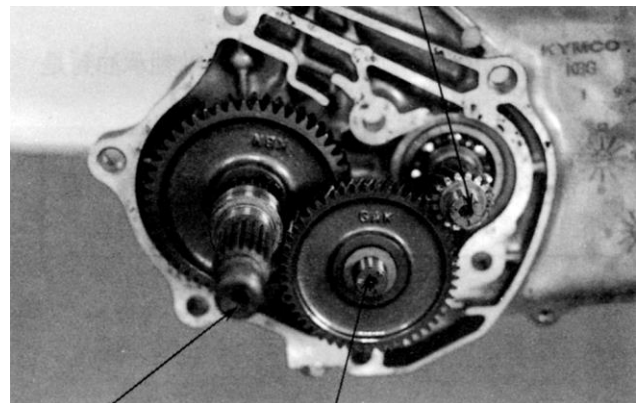

Final Gear

Countershaft

FINAL REDUCTION INSPECTION

Inspect the countershaft and gear for wear or damage.

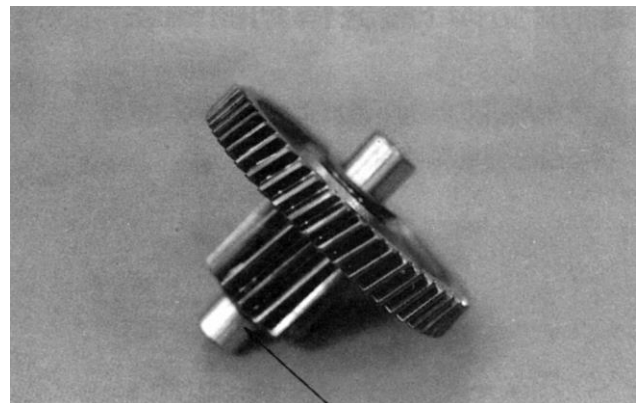

Countershaft

Inspect the final gear and final shaft for wear, damage or seizure.

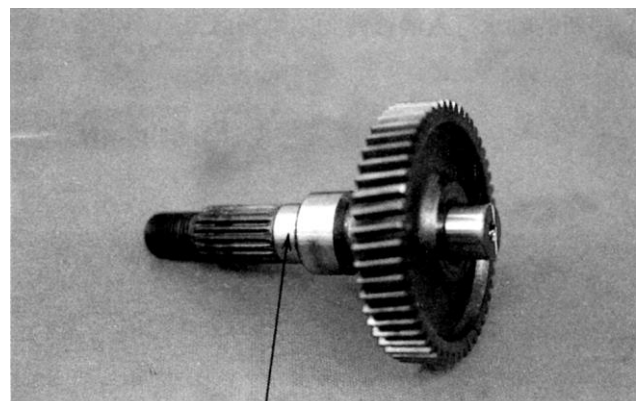

Final Shaft

10. FINAL REDUCTION

Check the left crankcase bearings for excessive play and inspect the oil seal for wear or damage.

Drive Shaft Bearing

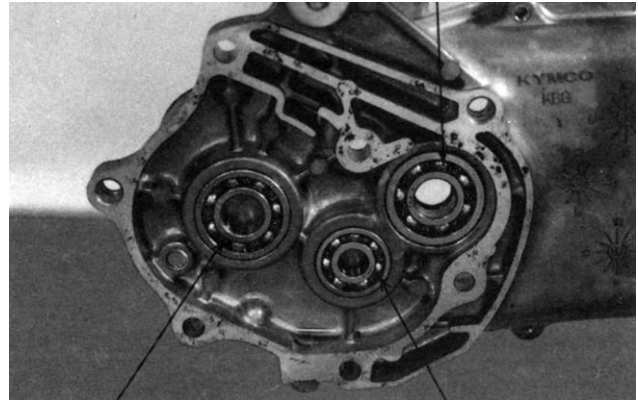

Final Shaft Bearing

Countershaft Bearing

Inspect the drive shaft and gear for wear or damage.
Check the transmission case cover bearings for excessive play and inspect the final shaft bearing oil seal for wear or damage.

* Do not remove the transmission case cover except for necessary part replacement. When replacing the drive shaft, also replace the bearing and

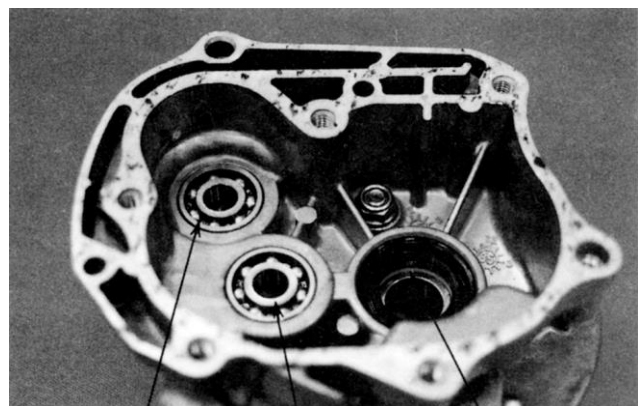

Countershaft Bearing Drive Shaft Bearing Oil Seal

Final Shaft Bearing

BEARING REPLACEMENT (TRANSMISSION CASE COVER)

Remove the transmission case cover bearings using a bearing puller.
Remove the final shaft oil seal.

Special

Bearing Puller

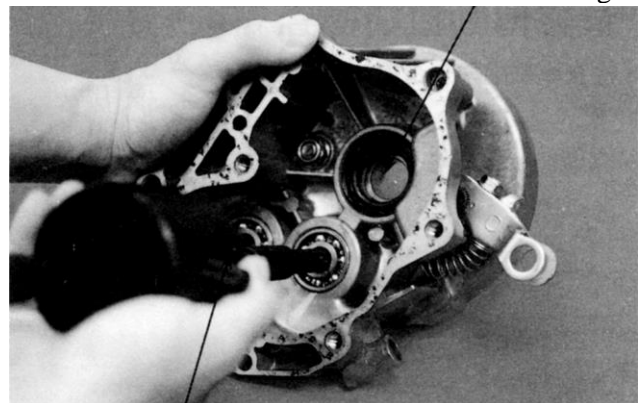

Bearing Puller

Drive new bearings into the transmission case cover.



Outer Driver, 32x35mm

10. FINAL REDUCTION

BEARING REPLACEMENT (LEFT CRANKCASE)

Remove the drive shaft.
Remove the drive shaft oil seal.
Remove the left crankcase bearings using a bearing puller.

Special

Bearing Puller

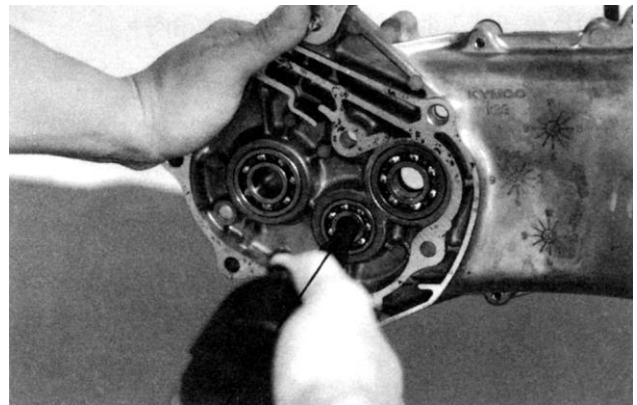

Bearing Puller, 12mm

Drive new bearings into the left crankcase.
Install a new drive shaft oil seal.

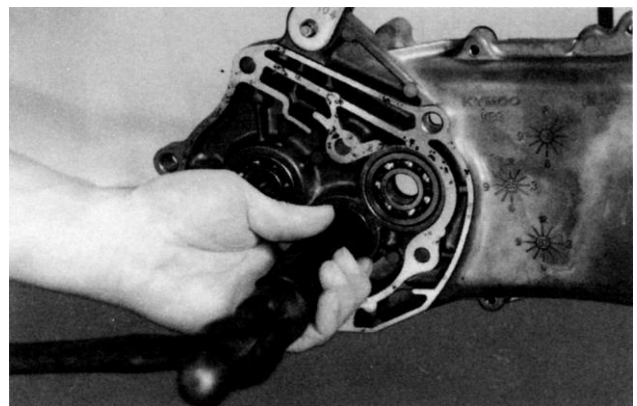

Pilot

FINAL REDUCTION ASSEMBLY

Install the drive shaft into the left crankcase.

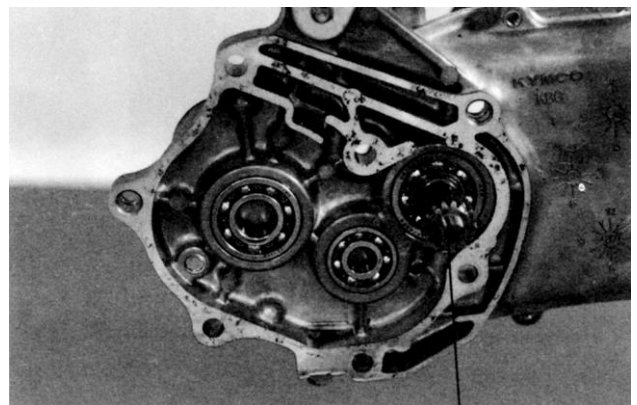

Drive Shaft

Install the final gear and final shaft into the left crankcase.

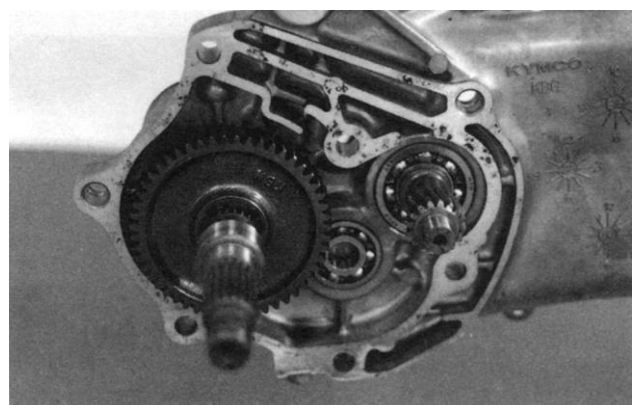

10. FINAL REDUCTION

Install the countershaft and gear into the left crankcase.
 Install the resin washer onto the countershaft.
 Install the dowel pins and a new gasket.

Resin Washer

Countershaft

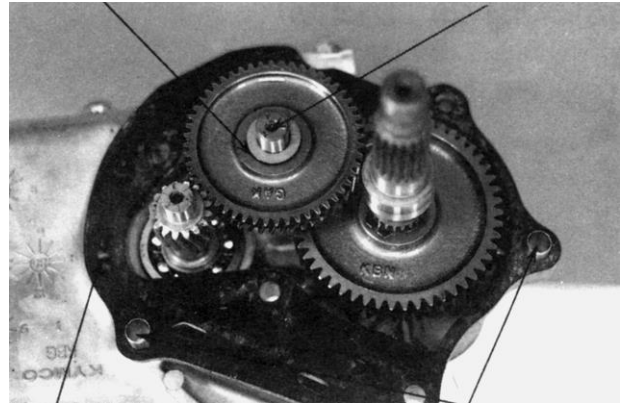

Gasket

Dowel Pins

Install the transmission case cover.



Transmission Case Cover

Install and tighten the transmission case cover bolts.
 Install the clutch/driven pulley. (⇒9-13)

After installation, fill the transmission case with the specified oil. (⇒3-7)

- Place the motorcycle on its main stand on level ground.
- Check the oil sealing washer for wear or damage.

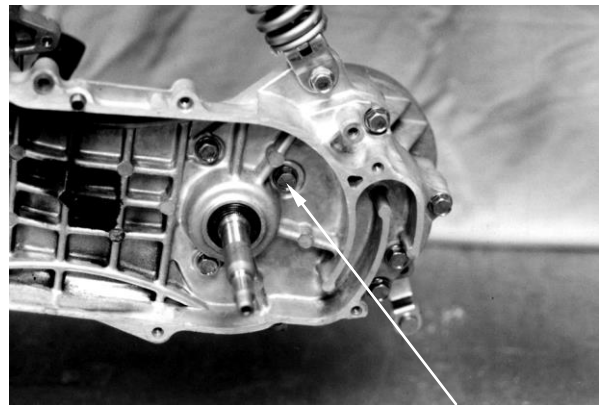

Bolt

Specified Gear Oil: SAE90#

Oil Capacity:

At disassembly : 0.18 liter

At change : 0.15 liter

Install and tighten the oil check bolt.

Torque: 0.8~1.2kgf-m

Start the engine and check for oil leaks.
 Check the oil level from the oil check bolt hole and add the specified oil to the proper level if the oil level is low.

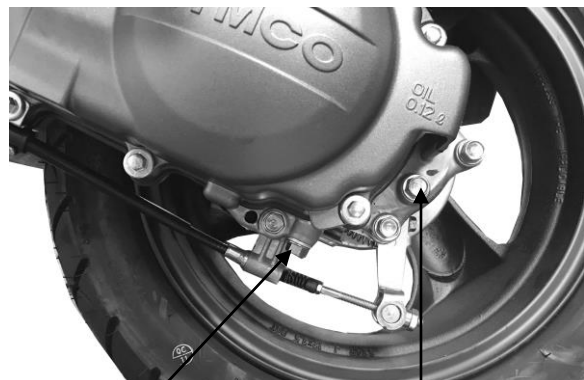

Drain Bolt

Oil Check Bolt Hole/Oil Filler

11. CRANKCASE/CRANKSHAFT

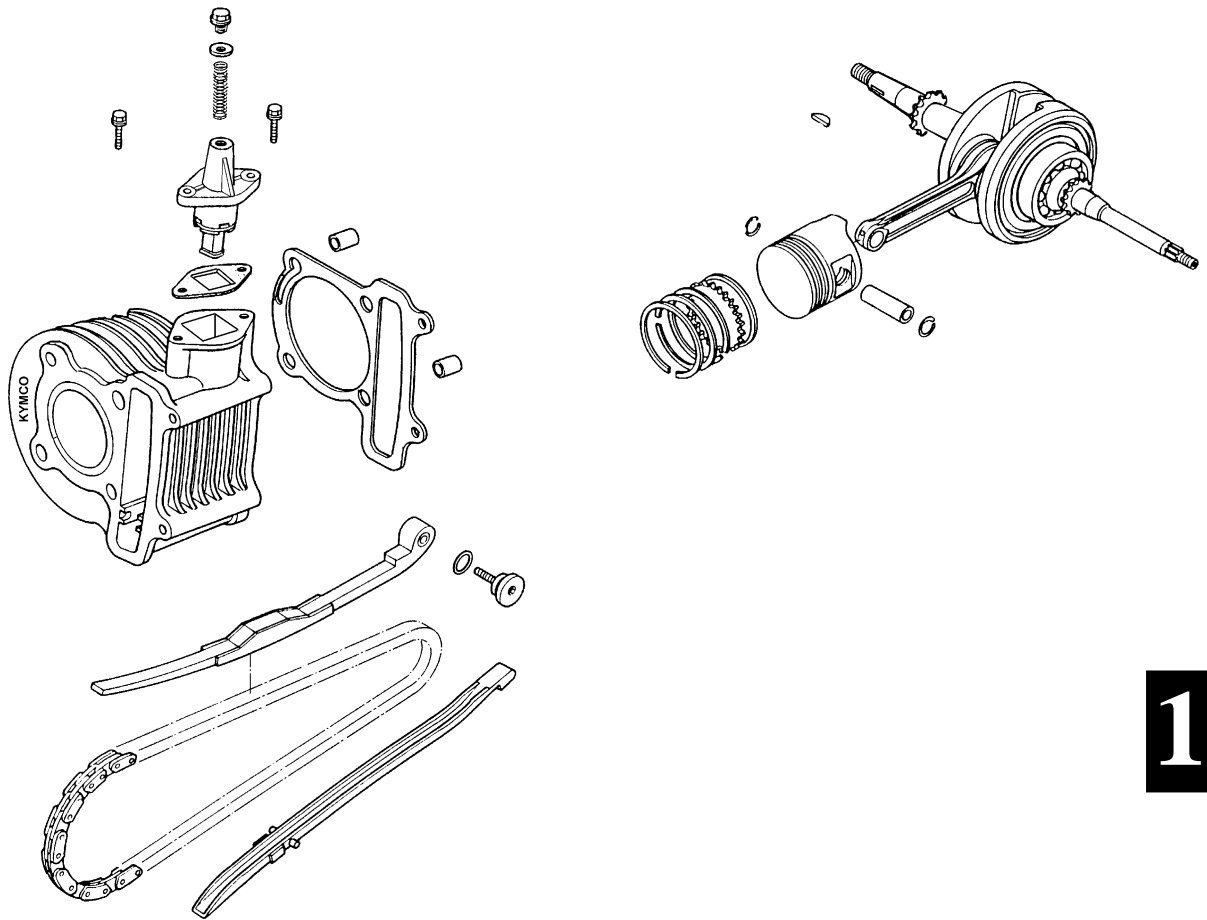

11

11. CRANKCASE/CRANKSHAFT

SERVICE INFORMATION.....	11-1	CRANKSHAFT.....	11-3
TROUBLESHOOTING	11-1	CRANKCASE ASSEMBLY.....	11-4
CRANKCASE SEPARATION	11-2		

SERVICE INFORMATION

GENERAL INSTRUCTIONS

- This section covers crankcase separation to service the crankshaft. The engine must be removed for this operation.
- The following parts must be removed before separating the crankcase.
 - Cylinder head (⇒Section 7)
 - Cylinder/piston (⇒Section 8)
 - Drive and driven pulleys (⇒Section 9)
 - A.C. generator (⇒Section 14)
 - Carburetor/air cleaner (⇒Section 5)
 - Rear wheel/rear shock absorber (⇒Section 13)
 - Starter motor (⇒Section 16)
 - Oil pump (⇒Section 4)

SPECIFICATIONS

	Item	Standard (mm)	Service Limit (mm)
Crankshaft	Connecting rod big end side clearance	0.10~0.35	0.55
	Connecting rod big end radial clearance	0-0.008	0.05
	Runout	—	0.10

TORQUE VALUES

Crankcase bolt	0.8~1.2kgf-m
Cam chain tensioner slipper bolt	0.8~1.2kgf-m

TROUBLESHOOTING

Excessive engine noise

- Excessive bearing play
- Excessive crankpin bearing play

11. CRANKCASE/CRANKSHAFT

CRANKCASE SEPARATION

Remove the cam chain tensioner slipper bolt and cam chain tensioner slipper.

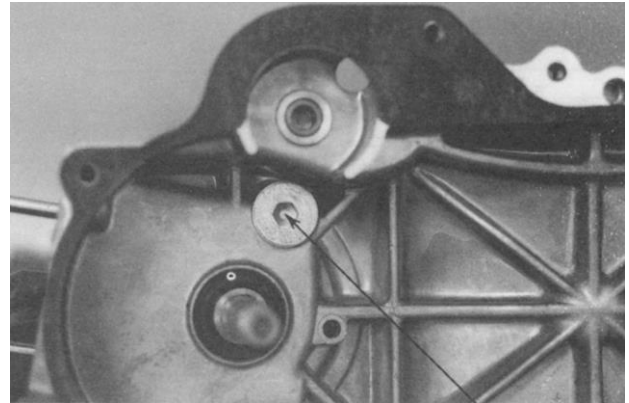

Cam Chain Tensioner Slipper Bolt

Remove the crankcase attaching bolt. Separate the left and right crankcase halves.

- *
 - Do not damage the crankcase gasket surface.
 - Never use a driver to pry the crankcase mating surfaces apart.

Crankcase Bolt

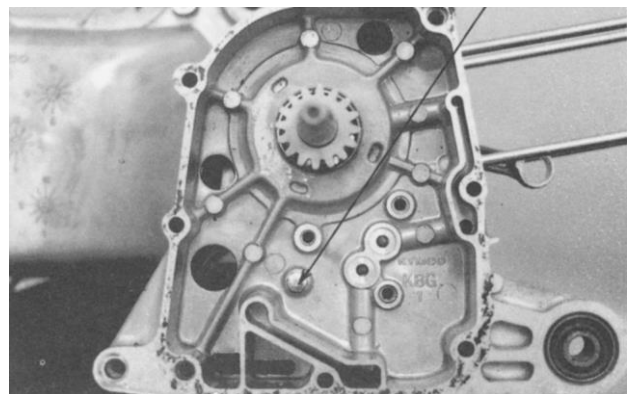

Remove the gasket and dowel pins.

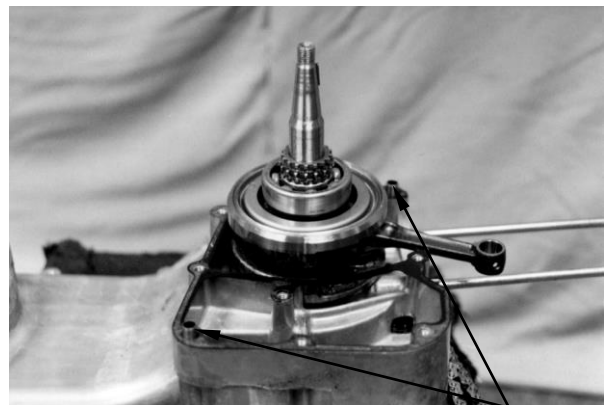

Dowel Pins

Remove the crankshaft from the left crankcase.
Remove the cam chain.

Cam Chain

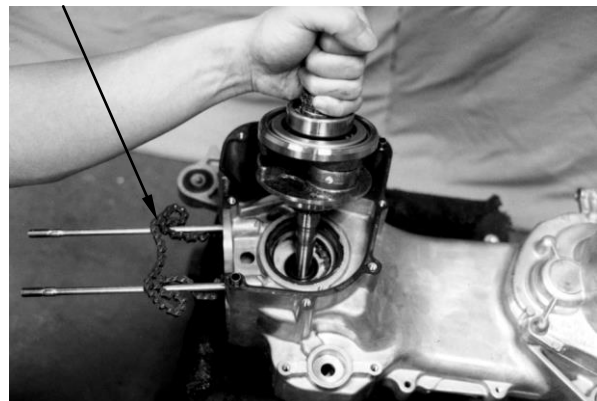

11. CRANKCASE/CRANKSHAFT

Clean off all gasket material from the crankcase mating surfaces.

* Avoid damaging the crankcase mating surfaces.

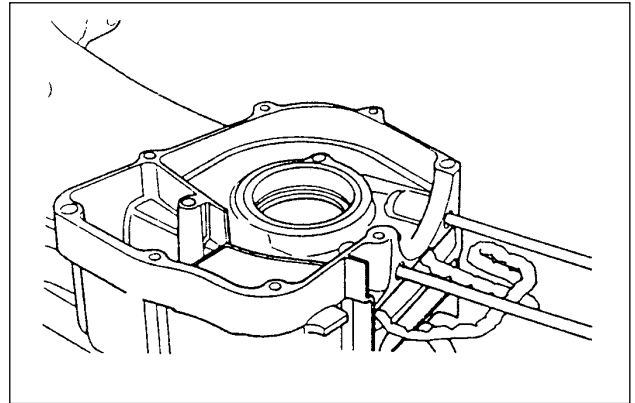

Remove the oil seal from the left crankcase.

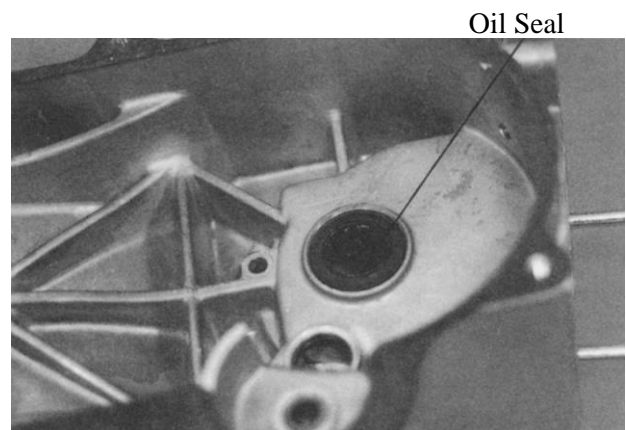

Remove the oil seal from the right crankcase.

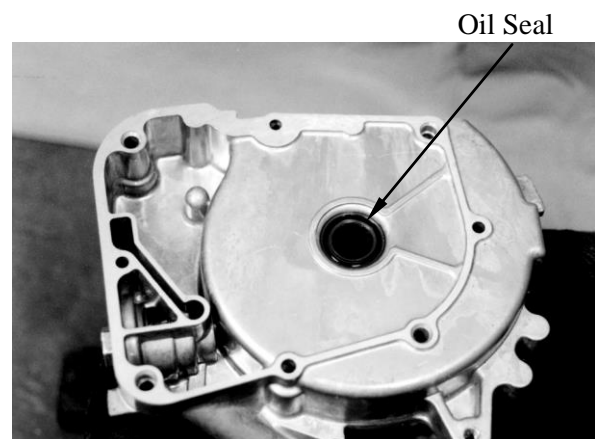

CRANKSHAFT

Measure the connecting rod big end side clearance.

Service Limit: 0.55mm replace if over

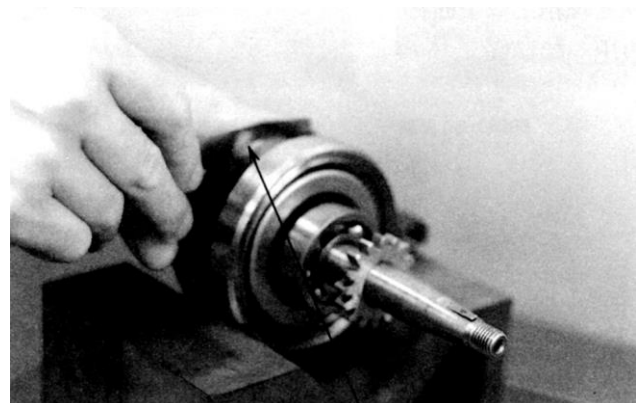

Connecting Rod Big End

11. CRANKCASE/CRANKSHAFT

Measure the connecting rod big end radial clearance at two points at right angels to the shaft.

Service Limit: 0.05mm replace if over

Measuring Location

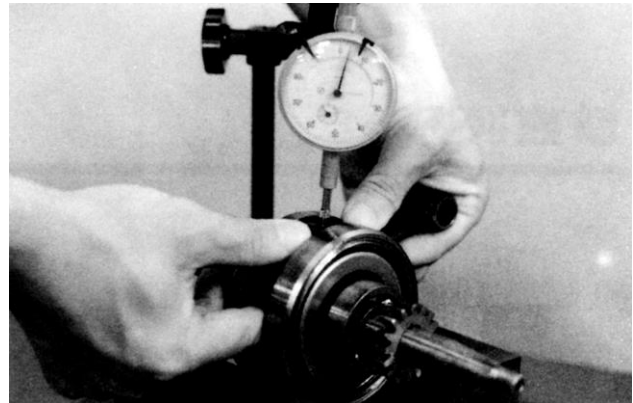

Measure the crankshaft runout.

Service Limit: 0.10mm replace if over

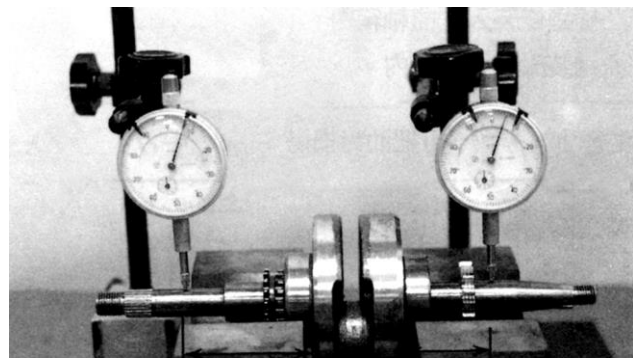

Turn the crankshaft bearings and check for excessive play.
If they do not turn smoothly, quietly or if they fit loosely in the crankshaft, replace the crankshaft as a set.

Crankshaft Bearings

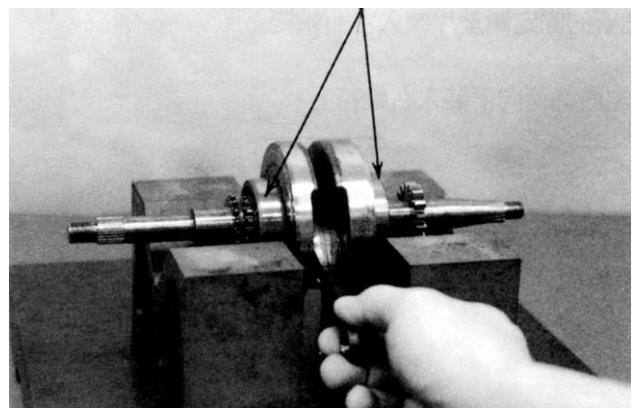

CRANKCASE ASSEMBLY

Install new oil seals into the right and left crankcase .

Driver Handle A

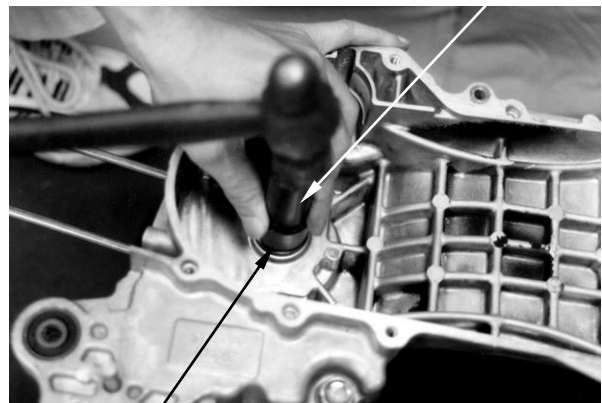

Outer Driver

11. CRANKCASE/CRANKSHAFT

Install the cam chain into the left crankcase.
Install the crankshaft into the left crankcase.

* When installing the cam chain, be careful not to damage the oil seal.

Install the dowel pins and a new gasket onto the left crankcase.

* Place the right crankcase over the crankshaft and onto the left crankcase.

Tighten the crankcase attaching bolt.
Torque: 0.8~1.2kgf-m

Driver Handle A

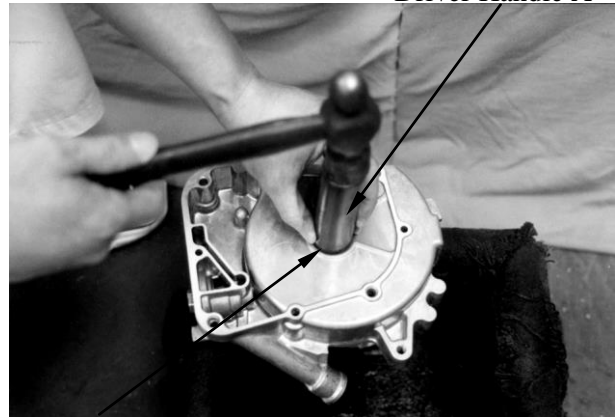

Outer Driver
Cam Chain

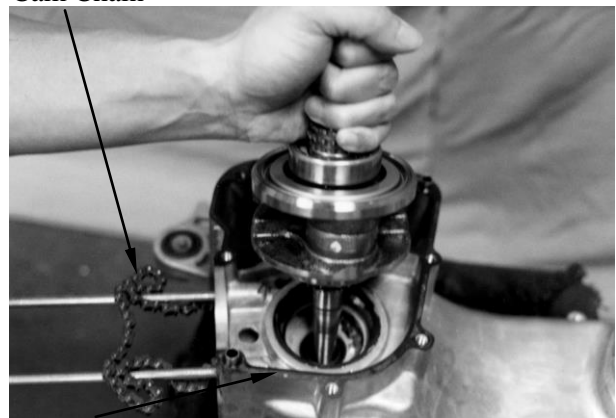

Gasket



Dowel Pins
Crankcase Bolt

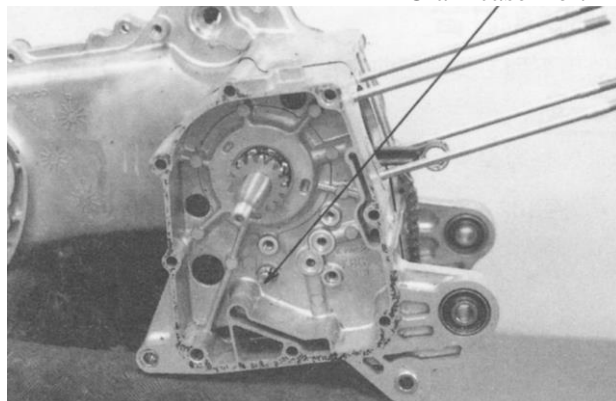

11. CRANKCASE/CRANKSHAFT

Install the cam chain tensioner slipper.
Install a new O-ring onto the cam chain tensioner slipper bolt.
Apply engine oil to the O-ring and tighten the bolt.

Torque: 0.8~1.2kgf-m

* Be sure to install the O-ring into the groove.

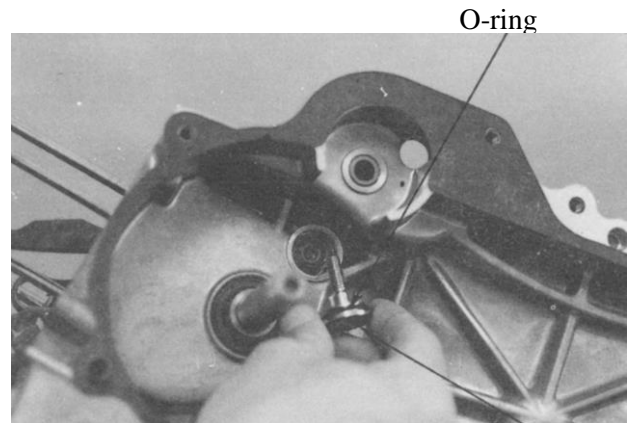

Cam Chain Tensioner Slipper Bolt

12. FRONT WHEEL/FRONT BRAKE/ FRONT SUSPENSION

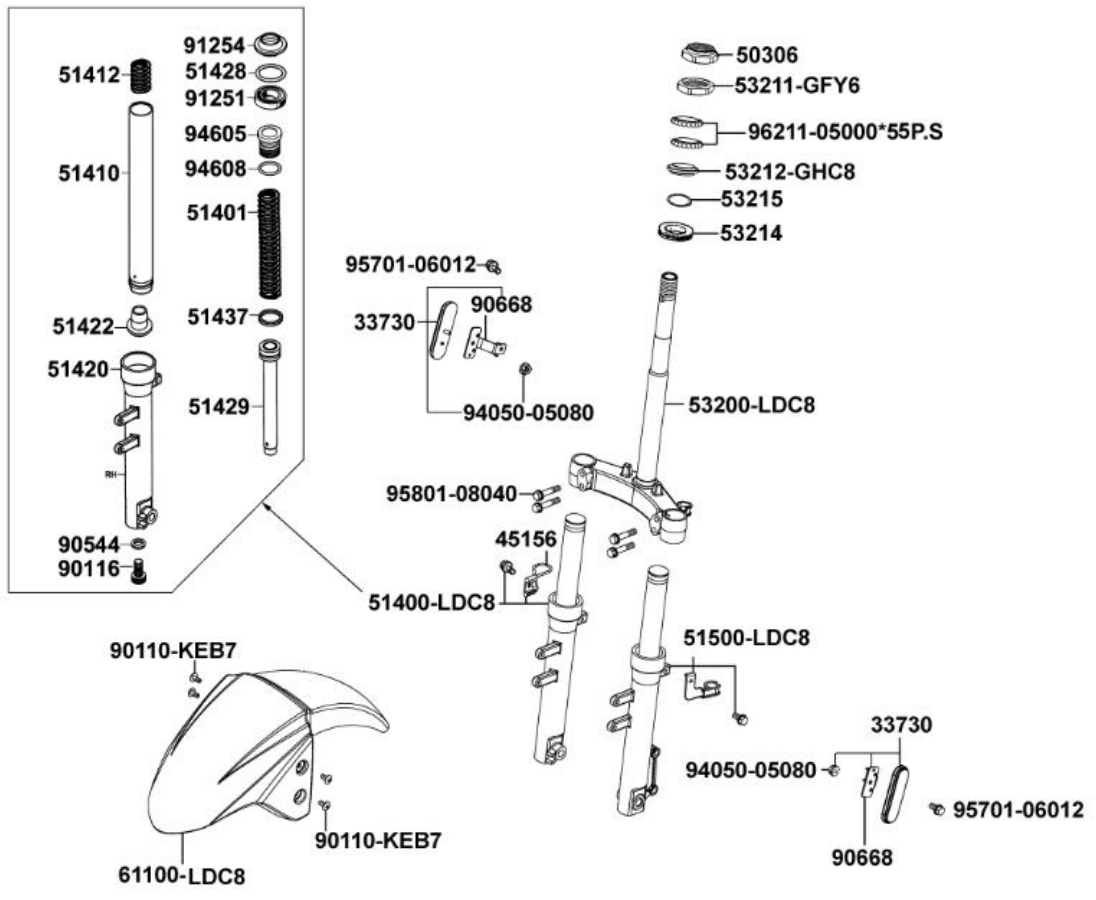
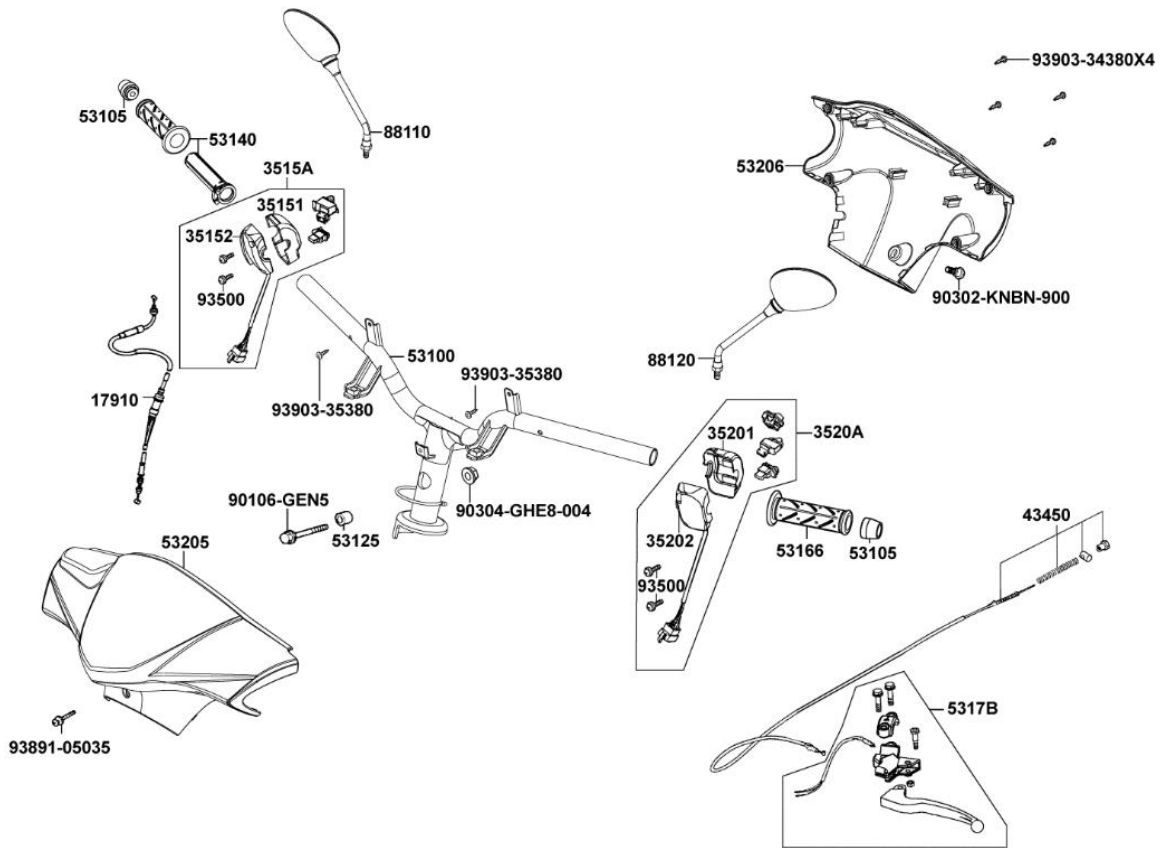

12

12. FRONT WHEEL/FRONT BRAKE/ FRONT SUSPENSION

SERVICE INFORMATION	12-1	FRONT BRAKE.....	12- 7
TROUBLESHOOTING	12-2	FRONT SHOCK ABSORBER.....	12-18
STEERING HANDLEBAR.....	12-3	FRONT FORK.....	12-21
FRONT WHEEL.....	12-4		

SERVICE INFORMATION

GENERAL INSTRUCTIONS

- Remove the motorcycle frame covers before removing the front wheel. Jack the motorcycle front wheel off the ground and be careful to prevent the motorcycle from falling down.
- During servicing, keep oil or grease off the brake drum and brake linings.

SPECIFICATIONS

Item		Standard (mm)	Service Limit (mm)
Axle shaft runout		—	0.2
Front wheel rim runout	Radial	—	2.0
	Axial	—	2.0
Front brake drum I.D		110	111
Front brake lining thickness		4.0	2.0
Front shock absorber spring free length		210.9	206.4

TORQUE VALUES

Handlebar bolt	4.5~5.5kgf-m
Steering stem lock nut	6.0~8.0kgf-m
Steering top cone race	0.5~1.3kgf-m
Front shock absorber bolt	3.0kgf-m
Front axle nut	5.0~7.0kgf-m
Brake arm bolt	0.8~1.2kgf-m

SPECIAL TOOLS

Long socket wrench,32mm 8angle

TROUBLESHOOTING

Hard steering (heavy)

- Excessively tightened steering stem top cone race
- Broken steering balls
- Insufficient tire pressure

Steers to one side or does not track straight

- Uneven front shock absorbers
- Bent front fork
- Bent front axle or uneven tire

Poor brake performance

- Incorrectly adjusted brake
- Worn brake linings
- Contaminated brake lining surface
- Worn brake shoes at cam contacting area
- Worn brake drum
- Poorly connected brake arm

Front wheel wobbling

- Bent rim
- Excessive wheel bearing play
- Bent spoke plate
- Faulty tire
- Improperly tightened axle nut

Soft front shock absorber

- Weak shock springs
- Insufficient damper oil

Front shock absorber noise

- Slider bending
- Loose fork fasteners
- Lack of lubrication

12. FRONT WHEEL/FRONT BRAKE/ FRONT SUSPENSION

STEERING HANDLEBAR

REMOVAL

Remove the handlebar front and rear covers.
(⇒2-2)
Remove the two bolts attaching each of the
front and rear brake levers.
Remove the front and rear brake levers.

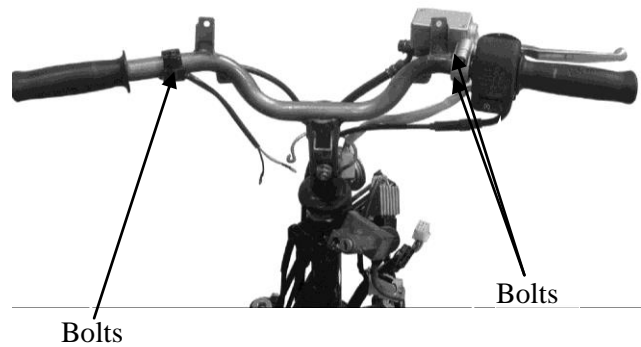

Remove the two throttle holder screws and
throttle holder.
Disconnect the throttle cable from the throttle
pipe and then remove the throttle pipe from
the handlebar.

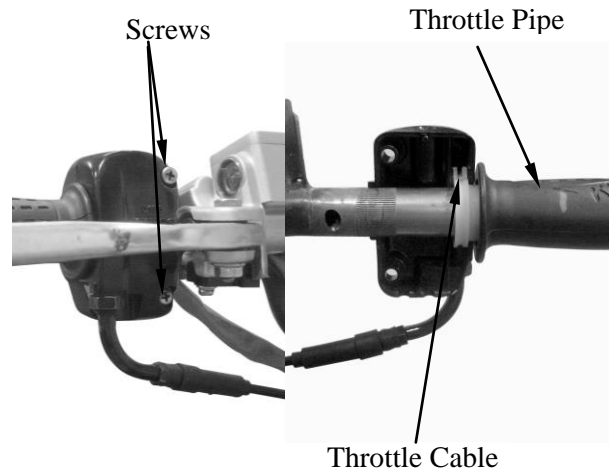

Remove the handlebar lock nut and bolt to
remove the handlebar.

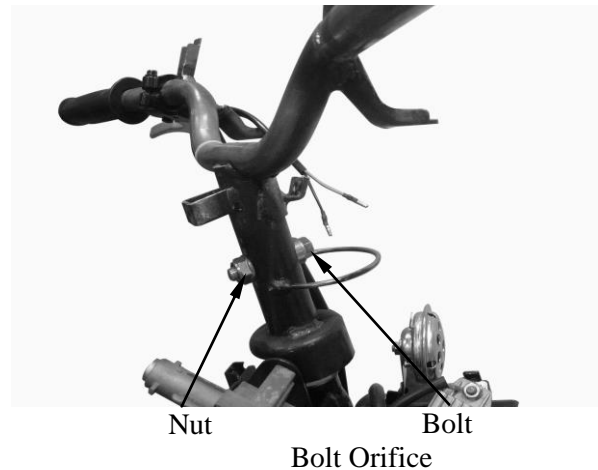

INSTALLATION

Install the handlebar onto the steering stem by
aligning the tab on the handlebar with the bolt
orifice on the steering stem.
Install and tighten the handlebar bolt and lock
nut.
Torque: 4.5~5.5kgf-m

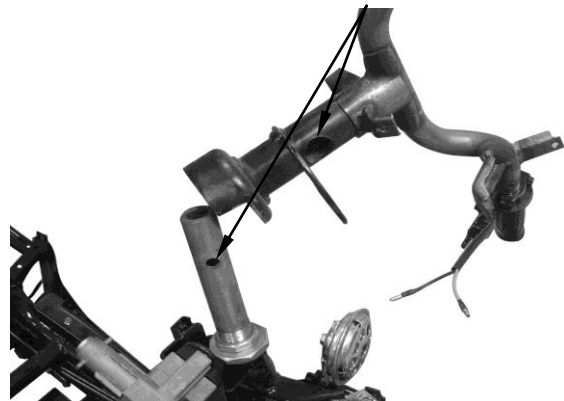

12. FRONT WHEEL/FRONT BRAKE/ FRONT SUSPENSION

Apply grease to the tip of the throttle pipe.
Install the throttle pipe and connect the
throttle cable.

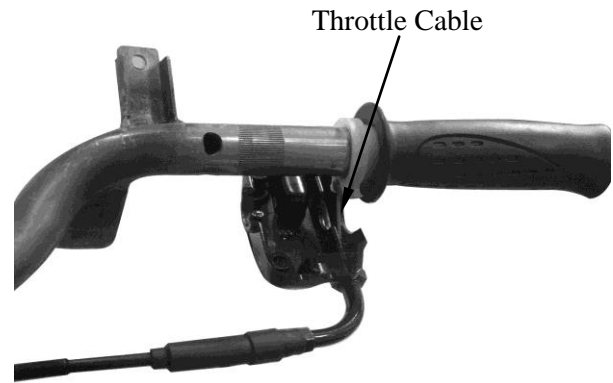

Install the front and rear brake levers in the
reverse order of removal.

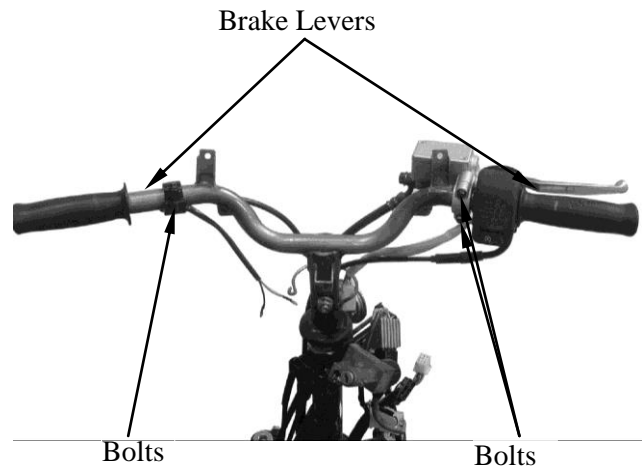

FRONT WHEEL REMOVAL

Jack the motorcycle front wheel off the
ground.
Remove the speedometer cable set screw and
disconnect the speedometer cable.
Remove the front brake cable.
Remove the front axle nut and pull out the
axle.
Remove the front wheel.
Remove the front brake panel and side collar.

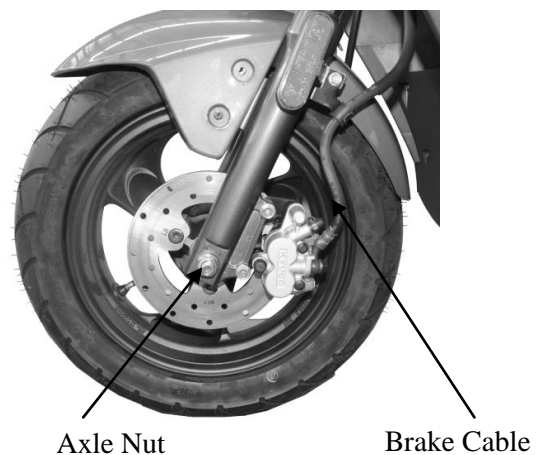

INSPECTION

AXLE RUNOUT

Set the axle in V blocks and measure the
runout using a dial gauge.
The actual runout is $\frac{1}{2}$ of the total indicator
reading.

Service Limit: 0.2mm replace if over

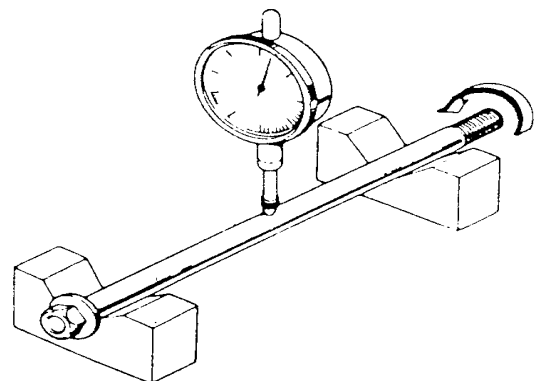

12. FRONT WHEEL/FRONT BRAKE/ FRONT SUSPENSION

WHEEL RIM

Check the wheel rim runout.

Service Limits:

Radial: 2.0mm replace if over

Axial: 2.0mm replace if over

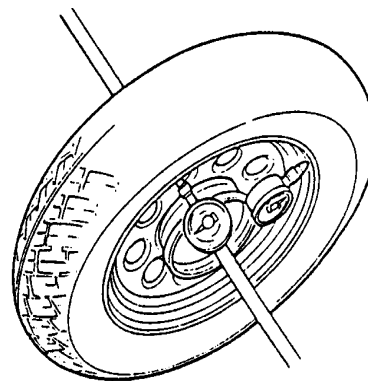

Turn the wheel bearings and replace the bearings if they are noisy or have excessive play.

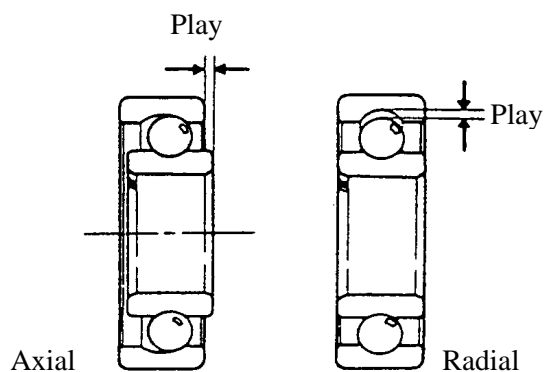

DISASSEMBLY

Remove the dust seal.

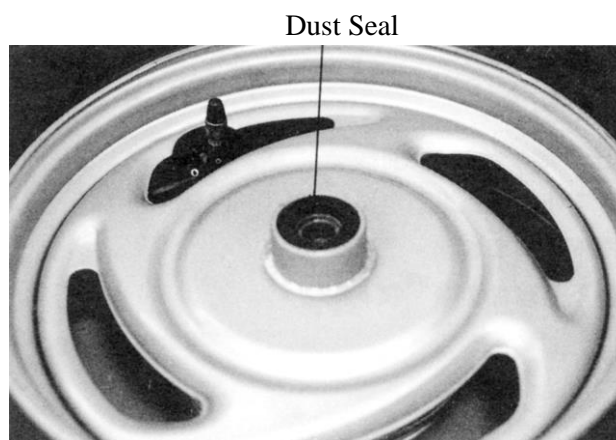

12. FRONT WHEEL/FRONT BRAKE/ FRONT SUSPENSION

Remove the front wheel bearings and distance collar.

Special

Bearing Puller

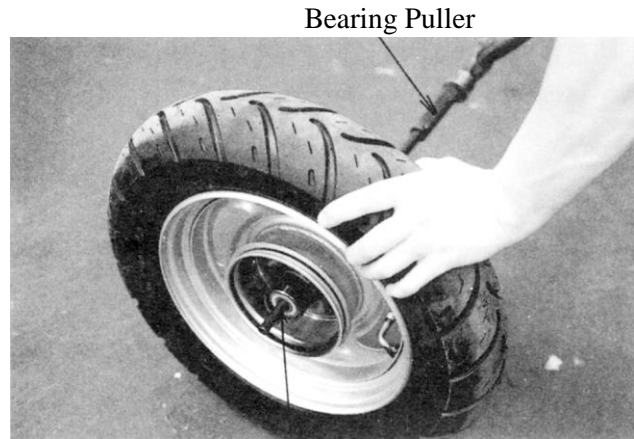

Bearing Puller

Pilot

ASSEMBLY

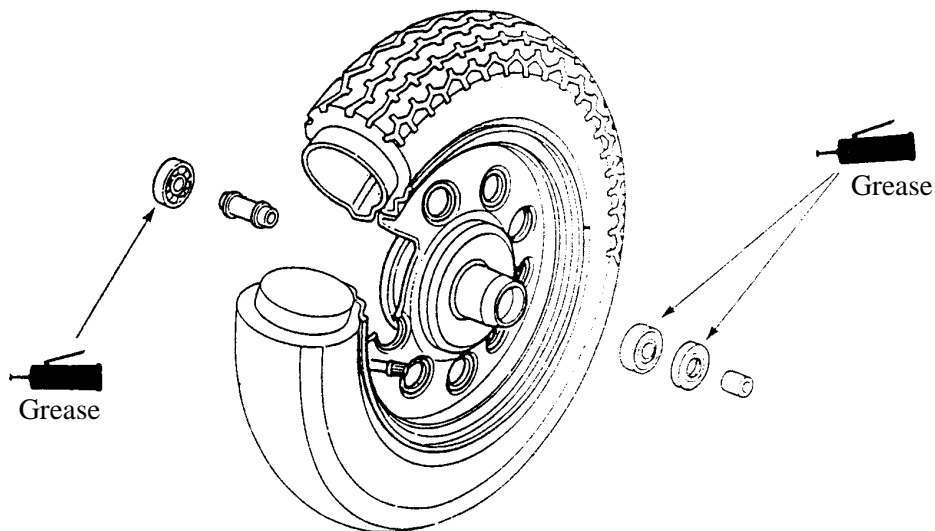

Pack all bearing cavities with grease.
Drive in the left bearing.
Install the distance collar.
Drive in the right bearing.

* Drive in the bearing squarely with the sealed end facing out.



Outer Driver
Pilot

12. FRONT WHEEL/FRONT BRAKE/ FRONT SUSPENSION

Apply grease to a new dust seal lip and install the dust seal.
Install the side collar.

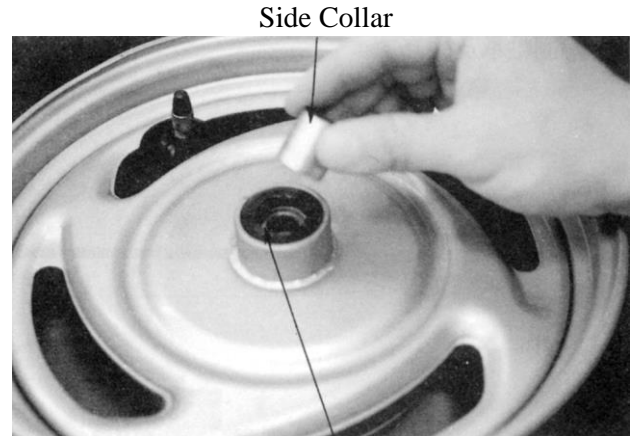

Dust Seal

INSTALLATION

Install the front wheel by aligning the brake panel groove with the front fork tab.
Insert the axle shaft and tighten the axle nut.

Torque: 4.5kg-m

Connect the speedometer cable and secure it with the screw.

Install the front brake cable and adjust the front brake lever free play.



Tab

FRONT BRAKE

Remove the front wheel. (⇒12-4)
Remove the front brake panel.

INSPECTION

Measure the brake drum I.D.

Service Limit: 111mm replace if over



Measure each brake lining thickness.

Service Limit: 2.00mmmm replace if below

* Keep oil or grease off the brake linings.

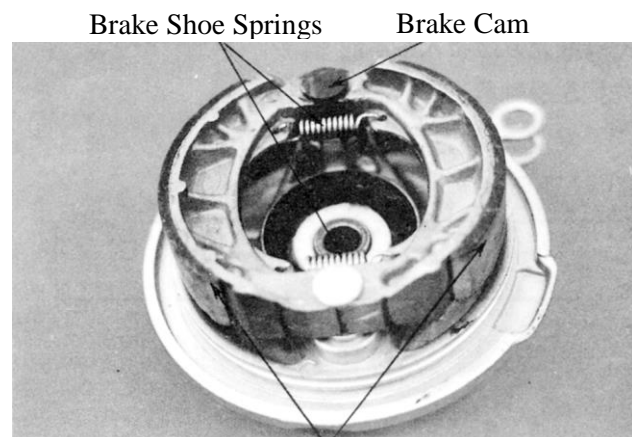

Brake Linings

12. FRONT WHEEL/FRONT BRAKE/ FRONT SUSPENSION

DISASSEMBLY

Do not swing the brake arm to expand the brake shoes.
Remove the brake shoes by removing the brake shoe springs using a screw driver.
Remove the brake arm and return spring.
Remove the wear indicator plate and felt seal.
Remove the brake cam.
Remove the dust seal and speedometer drive gear.

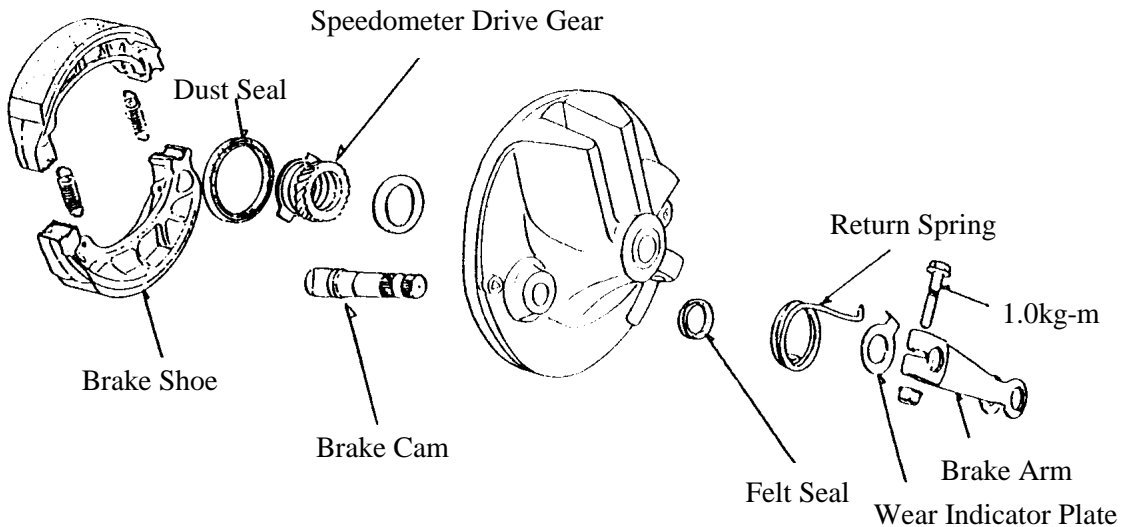

ASSEMBLY

Apply grease to the speedometer drive gear and then install it into the brake panel.
Apply grease to the dust seal lip and install it into the brake panel.

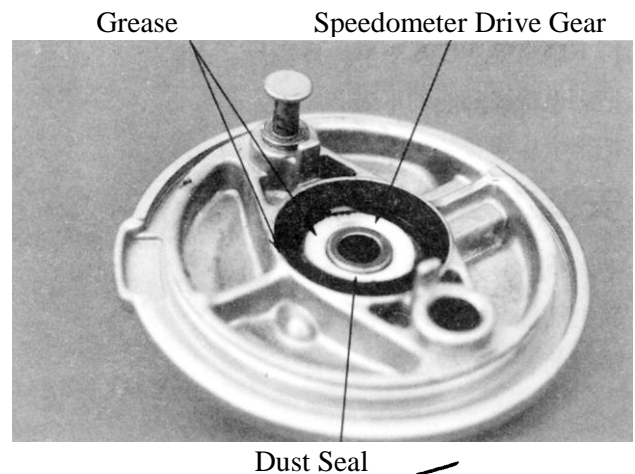

Apply grease to the anchor pin and brake cam.
Install the brake cam.

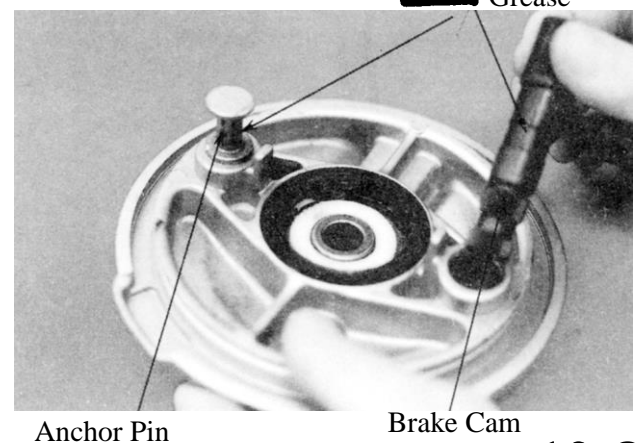

12. FRONT WHEEL/FRONT BRAKE/ FRONT SUSPENSION

Install the return spring by aligning the spring hook end with the hole in the brake panel.
Apply a small amount of engine oil to the felt seal and install it to the brake panel.
Install the wear indicator plate on the brake cam by aligning the tooth on the plate with the groove on the brake cam.

Wear Indicator Plate

Brake Cam

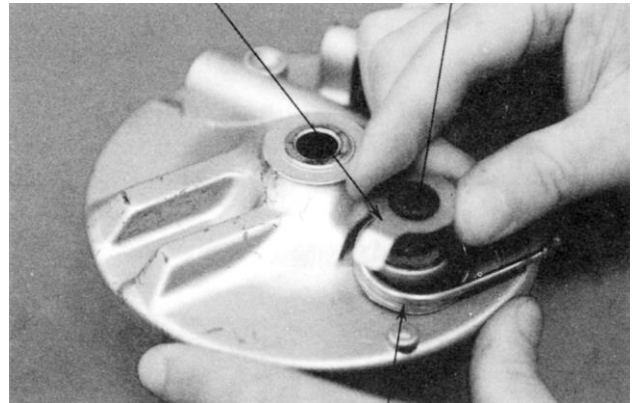

Return Spring

Install the brake arm on the brake cam by aligning the punch mark on the brake arm and the scribed line on the brake cam.
Install and tighten the brake arm bolt.

Torque:0.8~1.2kgf-m

Bolt

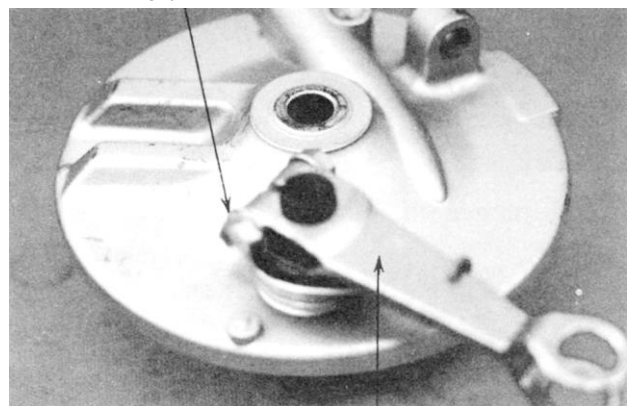

Brake Arm

Install the brake shoe springs to the brake shoes and then install the brake shoes into the brake panel.

INSTALLATION

Install the brake panel onto the front wheel.
Install the front wheel. (⇒12-7)
Adjust the front brake lever free play.

Brake Shoe Springs

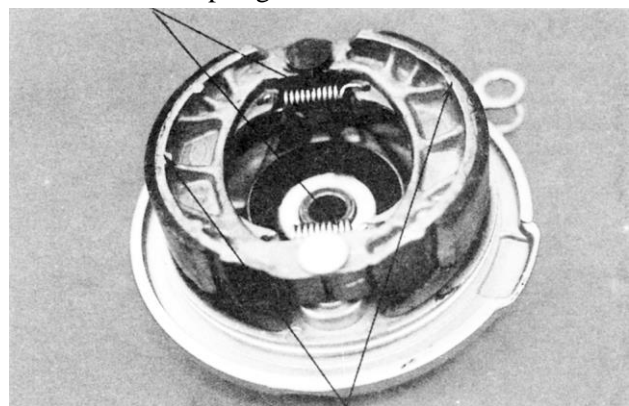

Brake Shoes

12. FRONT WHEEL/FRONT BRAKE/ FRONT SUSPENSION

HYDRAULIC BRAKE (FRONT BRAKE)

Brake Fluid Replacement/Air Bleeding

Check the brake fluid level on level ground.

- When operating the brake lever, the brake reservoir cap must be tightened securely to avoid spill of brake fluid.
- When servicing the brake system, use shop towels to cover plastic parts and coated surfaces to avoid damage caused by spill of brake fluid.

Upper Limit

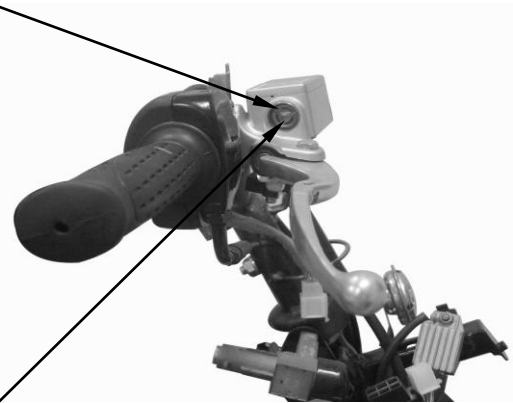

Lower Limit

Brake Fluid Bleeding

In order to avoid spill of brake fluid, connect a transparent hose to the bleed valve.

Warning

Brake fluid spilled on brake pads or brake disk will reduce the braking effect. Clean the brake pads and brake disk with a high quality brake degreaser.

Fully apply the brake lever and then loosen the brake caliper bleed valve to drain the brake fluid until there is no air bubbles in the brake fluid. Then, tighten the bleed valve. Repeat these steps until the brake system is free of air.

Bleed Valve

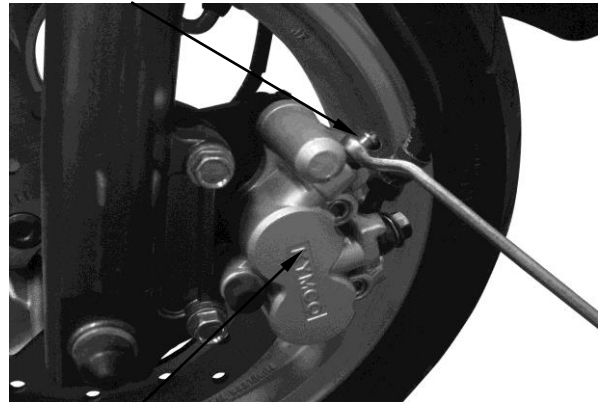

Front Brake Caliper

Brake Fluid Refilling

Add DOT-4 brake fluid to the brake reservoir.

- When bleeding, be careful not to allow air in the brake reservoir flowing into the brake system.
- When using a brake bleeder, follow the manufacturer's instructions.
- Never use dirty or unspecified brake fluid or mix different brake fluids because it will damage the brake

Make sure to bleed air from the brake system.

12. FRONT WHEEL/FRONT BRAKE/ FRONT SUSPENSION

Brake Pad/Disk Replacement

- * The brake pads must be replaced as a set to ensure the balance of the brake disk.

Remove the two bolts attaching the brake caliper.
Remove the brake caliper.

Remove the brake pad pins to remove the brake pads.

Pad Pin



Front Brake Caliper

Install the brake pads in the reverse order of removal.

Tighten the brake pad pin bolts.

Torque: 1.5~2.0kgf-m

- *
 - Keep grease or oil off the brake pads to avoid brake failure.
 - Do not reuse the brake pad pin bolts that have been removed.

Brake Pads



Front Brake Caliper

Brake Disk

Measure the brake disk thickness.

Service Limit: 3.0mm

Measure the brake disk runout.

Service Limit: 0.3mm



12. FRONT WHEEL/FRONT BRAKE/ FRONT SUSPENSION

BRAKE MASTER CYLINDER

Removal

First drain the brake fluid from the hydraulic brake system.

* _____

- When servicing the brake system, use shop towels to cover rubber and plastic parts and coated surfaces to avoid being contaminated by brake fluid.
- When removing the brake fluid pipe bolt, be sure to plug the pipe to avoid brake fluid leakage.

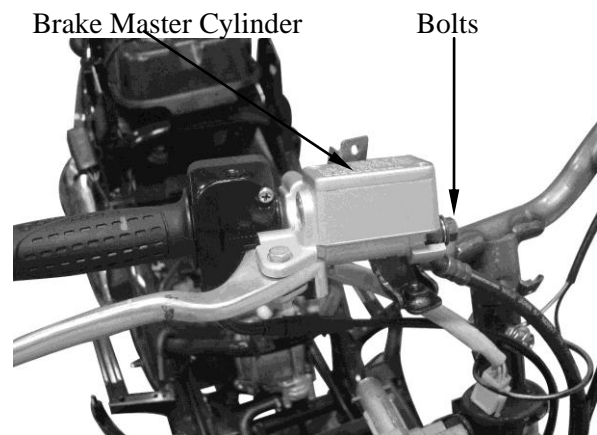

Disassembly

Remove the piston rubber cover and snap ring from the brake master cylinder.

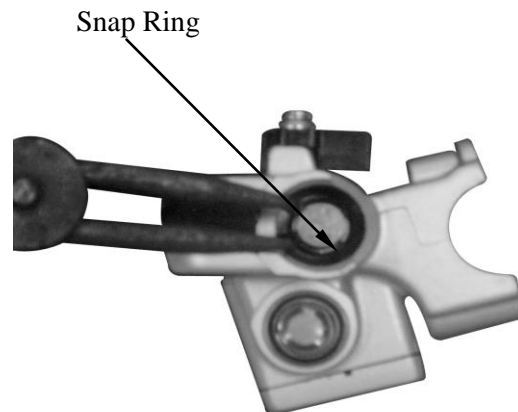

Remove the washer, main piston and spring from the brake master cylinder.
Clean the inside of the master cylinder and brake reservoir with brake fluid.

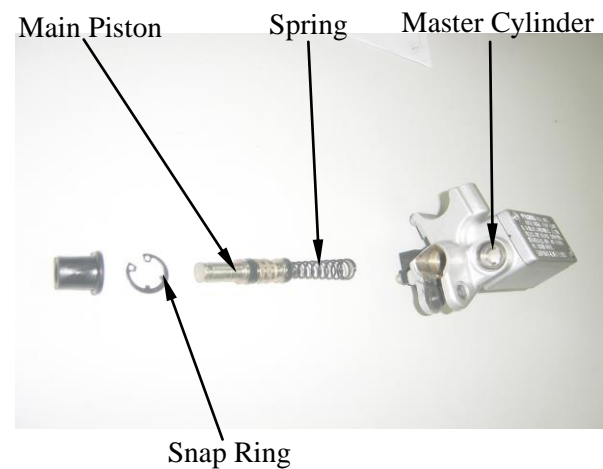

12. FRONT WHEEL/FRONT BRAKE/ FRONT SUSPENSION

Inspection

Measure the brake master cylinder I.D.

Service Limit: 12.75mm

Inspect the master cylinder for scratch or crack.

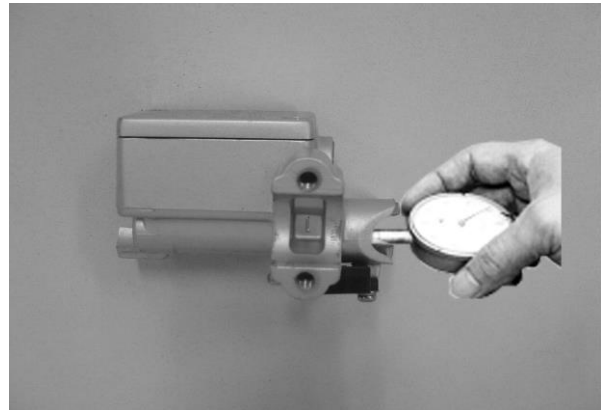

Measure the brake master cylinder piston O.D.

Service Limit: 12.6mm

Before assembly, inspect the 1st and 2nd rubber cups for wear.



Assembly

Before assembly, apply brake fluid to all removed parts.

Install the spring together with the 1st rubber cup.

*

- During assembly, the main piston and spring must be installed as a unit without exchange.
- When assembling the piston, soak the cups in brake fluid for a while.
- Install the cups with the cup lips facing the correct direction.



Install the main piston, spring and snap ring.

Install the rubber cover.

Install the brake lever.

12. FRONT WHEEL/FRONT BRAKE/ FRONT SUSPENSION

Disassembly

Remove the brake caliper seat from the brake caliper.

Brake Caliper Seat

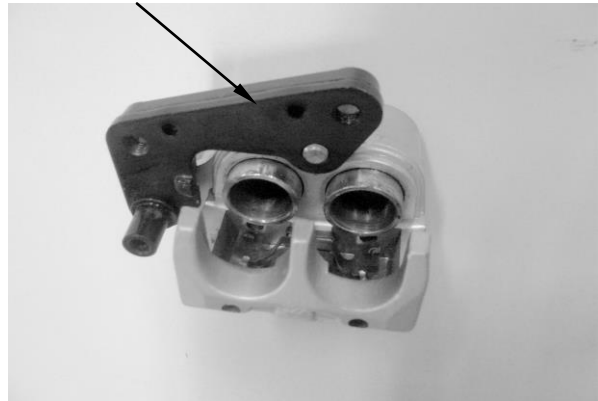

Remove the piston from the brake caliper. If necessary, use compressed air to squeeze out the piston through the brake fluid inlet opening and place a shop towel under the caliper to avoid contamination caused by the removed piston. Check the piston cylinder for scratch or wear and replace if necessary.

Compressed Air



Push the piston oil seal outward to remove it. Clean the oil seal groove with brake fluid.

*

Be careful not to damage the piston surface.

Piston Oil Seal



12. FRONT WHEEL/FRONT BRAKE/ FRONT SUSPENSION

Place the brake master cylinder on the handlebar and install the holder with “up” mark facing up. Be sure to align the punch mark with the holder joint. First tighten the upper bolt and then tighten the lower bolt.

Torque: 3.0~4.0kgf-m

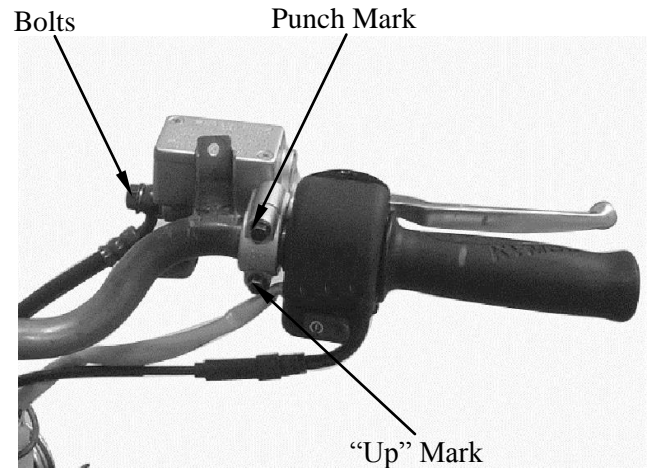

Install the brake fluid pipe with the attaching bolt and two sealing washers.

Install the handlebar covers. (⇒12-3)
Fill the brake reservoir with recommended brake fluid to the upper limit and bleed air according to the method stated in 12-10.

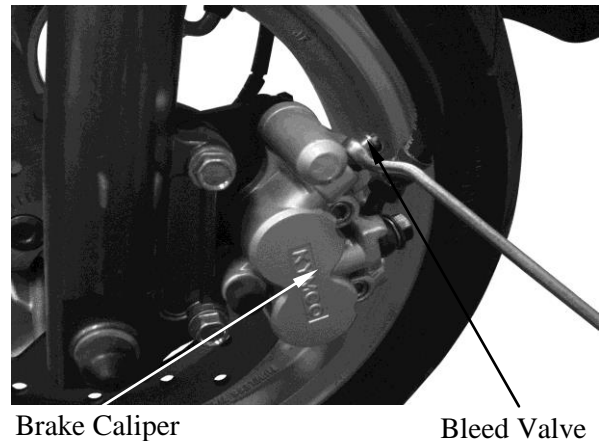

BRAKE CALIPER (FRONT)

Removal

Remove the brake caliper.
Place a clean container under the brake caliper and disconnect the brake fluid pipe from the caliper.

* Do not spill brake fluid on any coated surfaces.

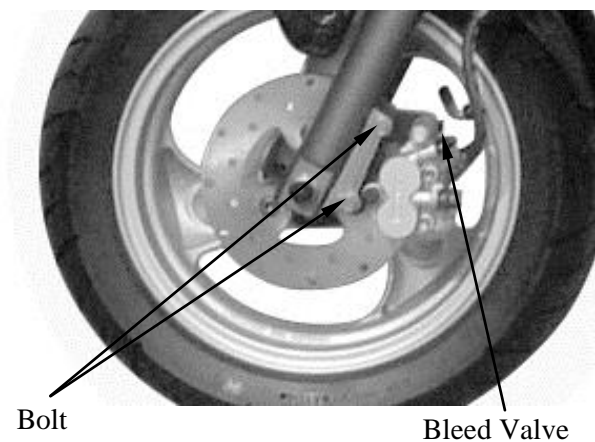

12. FRONT WHEEL/FRONT BRAKE/ FRONT SUSPENSION

Check the piston for scratch or wear.
Measure the piston O.D. with a micrometer.
Service Limit: 26.3mm



Check the caliper cylinder for scratch or wear
and measure the cylinder bore.
Service Limit: 26.45mm



Assembly

Clean all removed parts.
Apply silicon grease to the piston and oil seal.
Lubricate the brake caliper cylinder inside
wall with brake fluid.
Install the brake caliper piston with grooved
side facing out.

*

Install the piston with its outer end 3~
5mm protruding beyond the brake
caliper.

Wipe off excessive brake fluid with a clean
shop towel. Apply silicon grease to the
brake caliper seat pin and caliper inside.
Install the brake caliper seat.



12. FRONT WHEEL/FRONT BRAKE/ FRONT SUSPENSION

Installation

Install the brake caliper and tighten the two bolts.

Torque: 2.9~3.5kg-m



Connect the brake fluid pipe to the brake caliper and tighten the fluid pipe bolt.

Torque: 2.5~3.5kg-m

Fill the brake reservoir with recommended brake fluid and bleed air from the brake system. (⇒12-10)



12. FRONT WHEEL/FRONT BRAKE/ FRONT SUSPENSION

FRONT SHOCK ABSORBER

REMOVAL

Remove the front wheel. (⇒12-4)
Remove the front lower cover. (⇒2-2)
Remove the front inner fender.
Remove the front shock absorber upper mount bolts.
Loosen the lower mount bolts to remove the front shock absorbers.

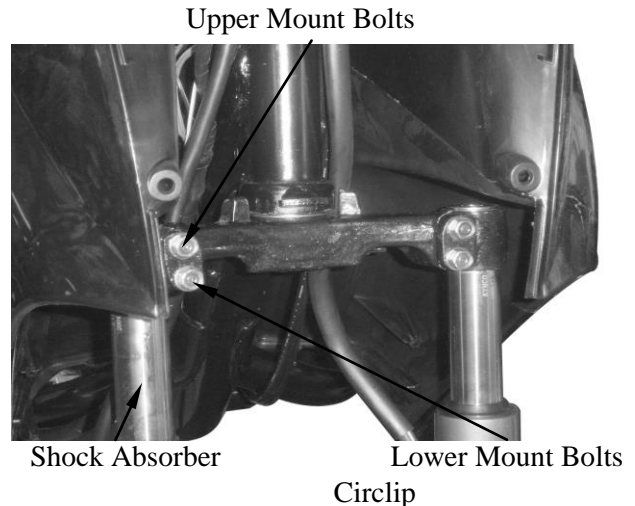

DISASSEMBLY

Remove the dust boot.
Remove the circlip.

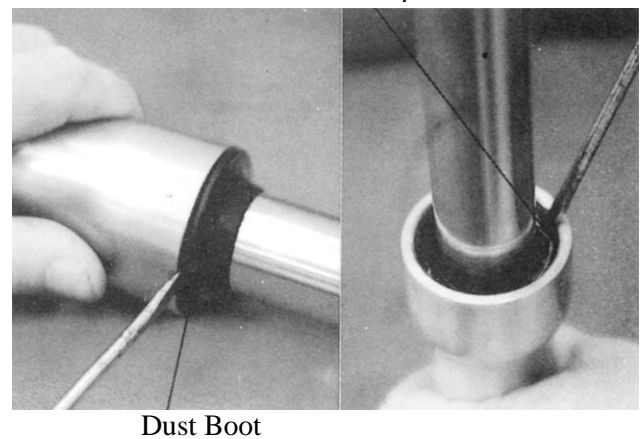

Set the front shock absorber in a vise.
Remove the damper rod, hex bolt and copper washer.
Pull out the front shock absorber tube.

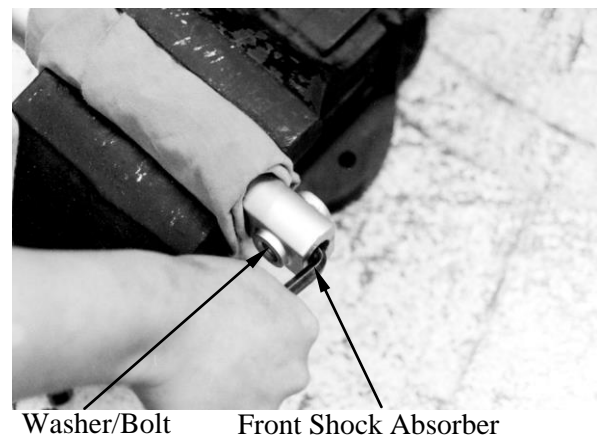

Set the front shock absorber tube in a vise.
Remove the top nut, shock spring, damper, and damper spring from the front shock absorber tube.

- * • When holding the shock absorber tube, place a shop towel to protect it and do not apply too much force.

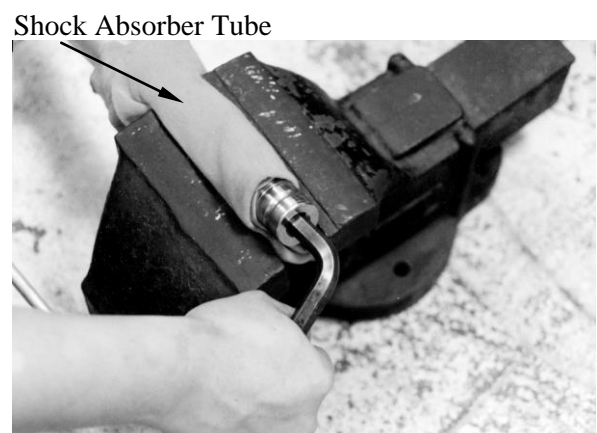

12. FRONT WHEEL/FRONT BRAKE/ FRONT SUSPENSION

Measure the front shock absorber spring free length.

Service Limits: Right : 206.4mm
Left : 206.4mm

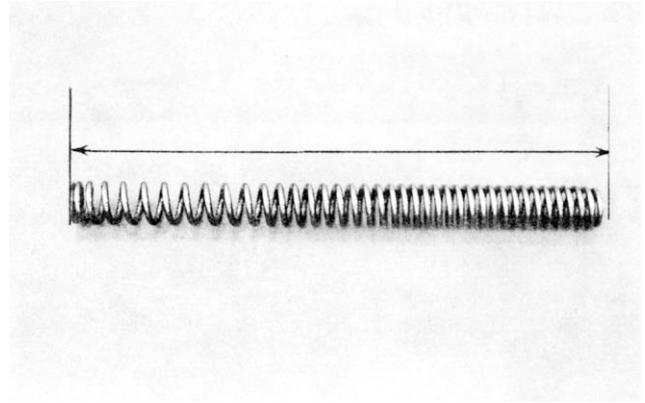

ASSEMBLY

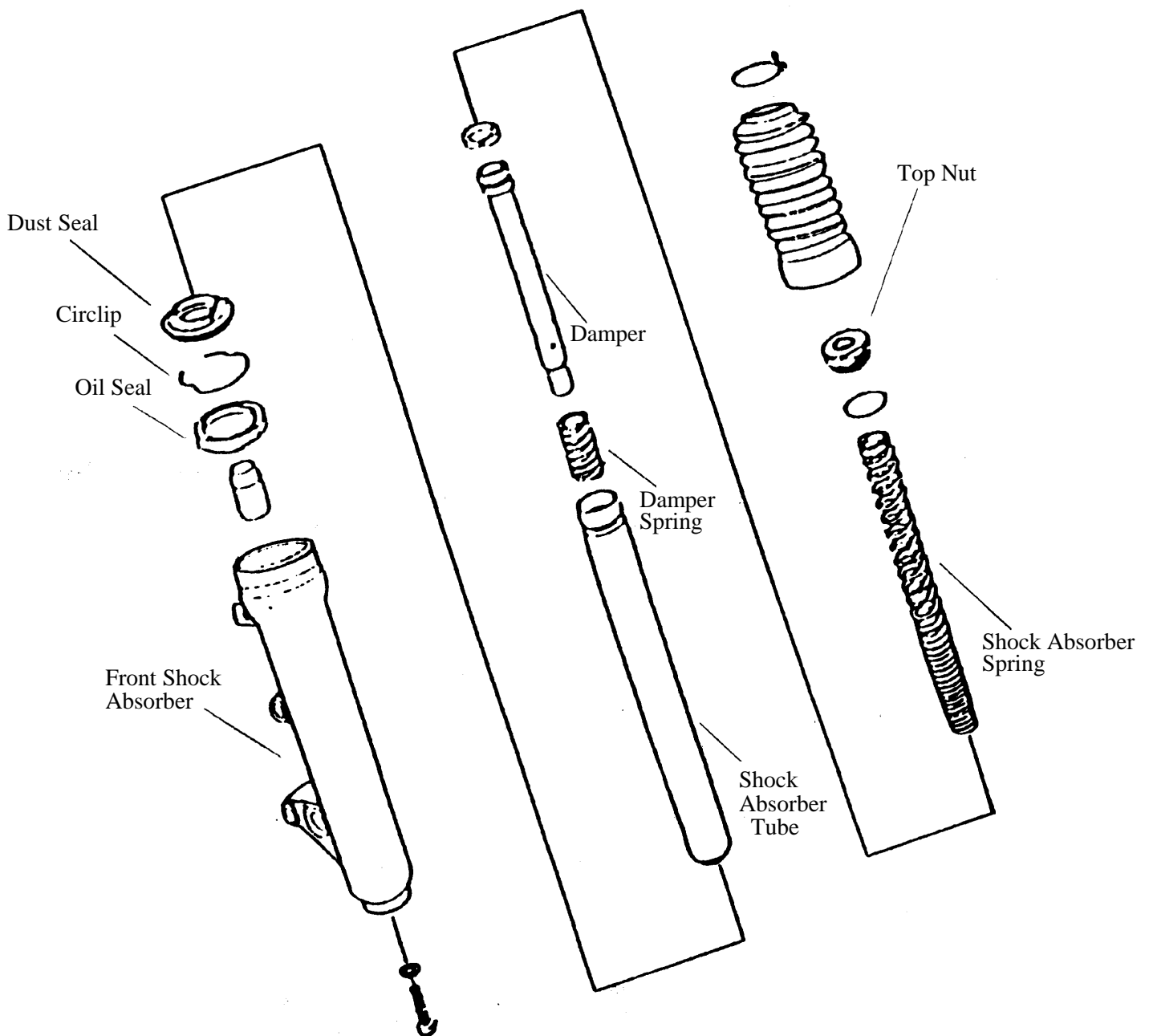

12. FRONT WHEEL/FRONT BRAKE/ FRONT SUSPENSION

Install the damper spring onto the damper rod and then install them into the front shock absorber tube.

Install the shock absorber spring onto the front shock absorber tube and tighten the top nut.

* Install the front shock absorber spring with the closely wound coils facing down.

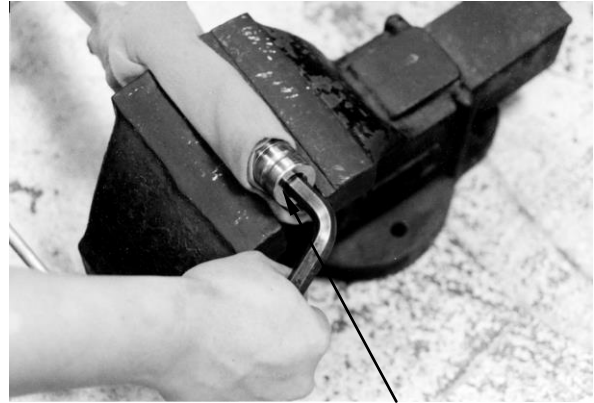

Shock Absorber Tube
Circlip

Set the front shock absorber in a vise. Insert the shock absorber tube into the shock absorber and tighten the hex bolt. (Apply locking agent to the washer and install it together with the hex bolt.)

Torque: 3.0kgf-m

Add engine oil into the front shock absorber.

Specified Oil: SS#8

Oil Capacity: 38±1cc

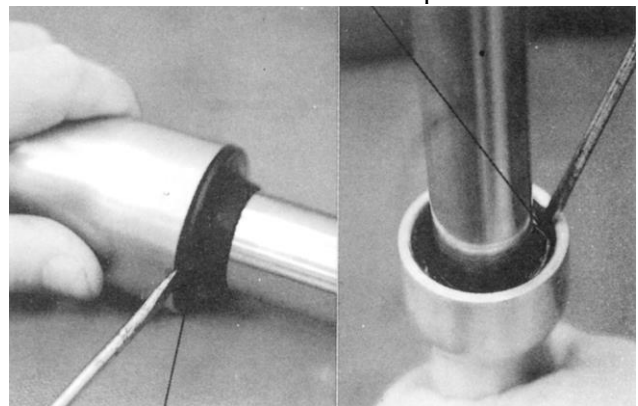

Dust Boot

Install the circlip.
Install the dust boot.

Upper Mount Bolts

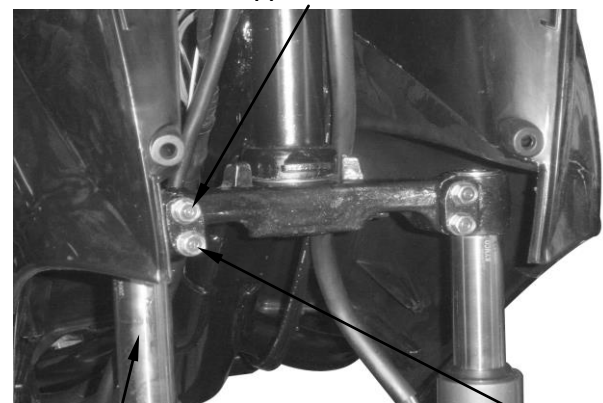

Front Shock Absorber

Lower Mount Bolts

INSTALLATION

Install the front shock absorbers onto the steering stem.

Install and tighten the front shock absorber upper mount bolts.

Tighten the lower mount bolts.

* Align the upper mount bolt hole with the groove on the front fork.

Install the front wheel. (⇒12-7)

12. FRONT WHEEL/FRONT BRAKE/ FRONT SUSPENSION

FRONT FORK

REMOVAL

Remove the steering handlebar. (⇒12-3)
Remove the front wheel. (⇒12-4)
Disconnect the speedometer cable.
Remove the steering stem lock nut using long socket wrench.

Special

Long Socket Wrench, 32mm 8Angle

Long Socket Wrench

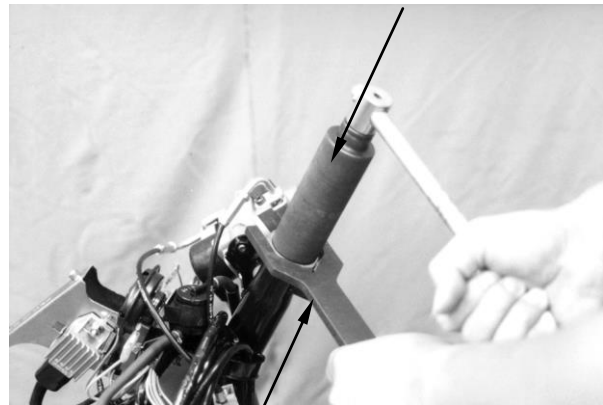

Lock Nut Wrench

Remove the top cone race and remove the steering stem.

*

- Be careful not to lose the steel balls (26 on top race and 29 on bottom race).

Inspect the ball races and cone races for wear or damage and replace if necessary.



Top Cone Race

BOTTOM CONE RACE REPLACEMENT

Remove the bottom cone race using a chisel.

*

- Be careful not to damage the steering stem and front fork.

Drive a new bottom cone race into place with a proper driver.



Bottom Cone Race

BALL RACE REPLACEMENT

Drive out the top and bottom ball races.

Ball Race Remover

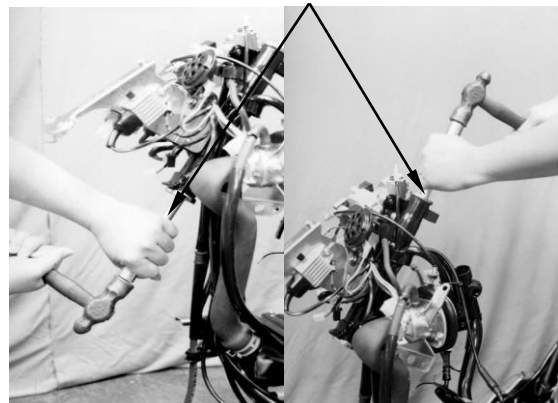

12. FRONT WHEEL/FRONT BRAKE/ FRONT SUSPENSION

Drive new top and bottom ball races into the steering head using the outer driver.

- * Be sure to completely drive in the ball races.

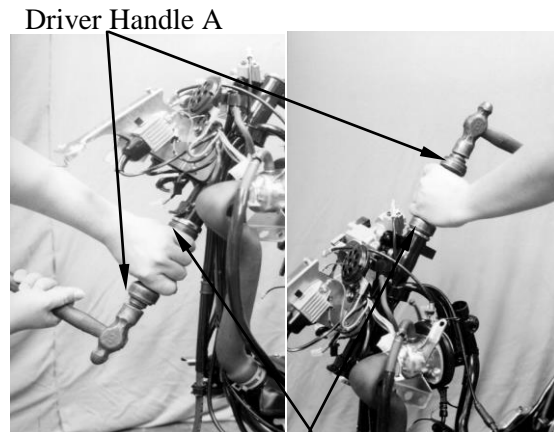

Outer Driver, 37x40mm

INSTALLATION

Apply grease to the top and bottom ball races and install 26 steel balls on the top ball race and 29 steel balls on the bottom ball race.

Apply grease to the ball races and install the front fork.



Steel Balls

Apply grease to the top cone race and install it.

Tighten the top cone race and then turn the steering stem right and left several times to make steel balls contact each other closely.

- * Check that the steering stem rotates freely without vertical play.

Top Cone Race



Long Socket Wrench

Install the steering stem lock nut and tighten it while holding the top cone race.

Torque: 6.0~8.0kgf-m

Install the front wheel. (⇒12-7)

Install the steering handlebar. (⇒12-3)

Install the speedometer cable. (⇒12-7)

Special

Long Socket Wrench, 32mm 8Angle

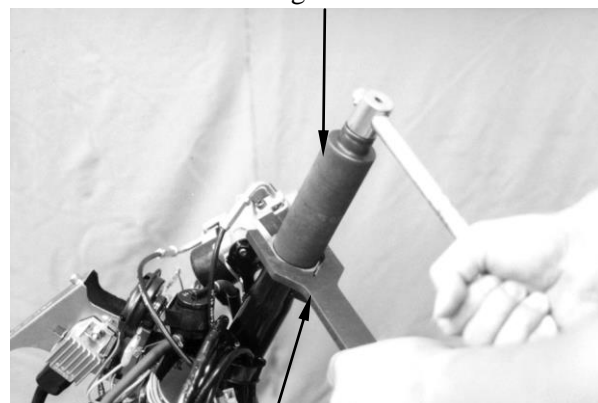

Lock Nut Wrench

13. REAR WHEEL/REAR BRAKE/ REAR SUSPENSION

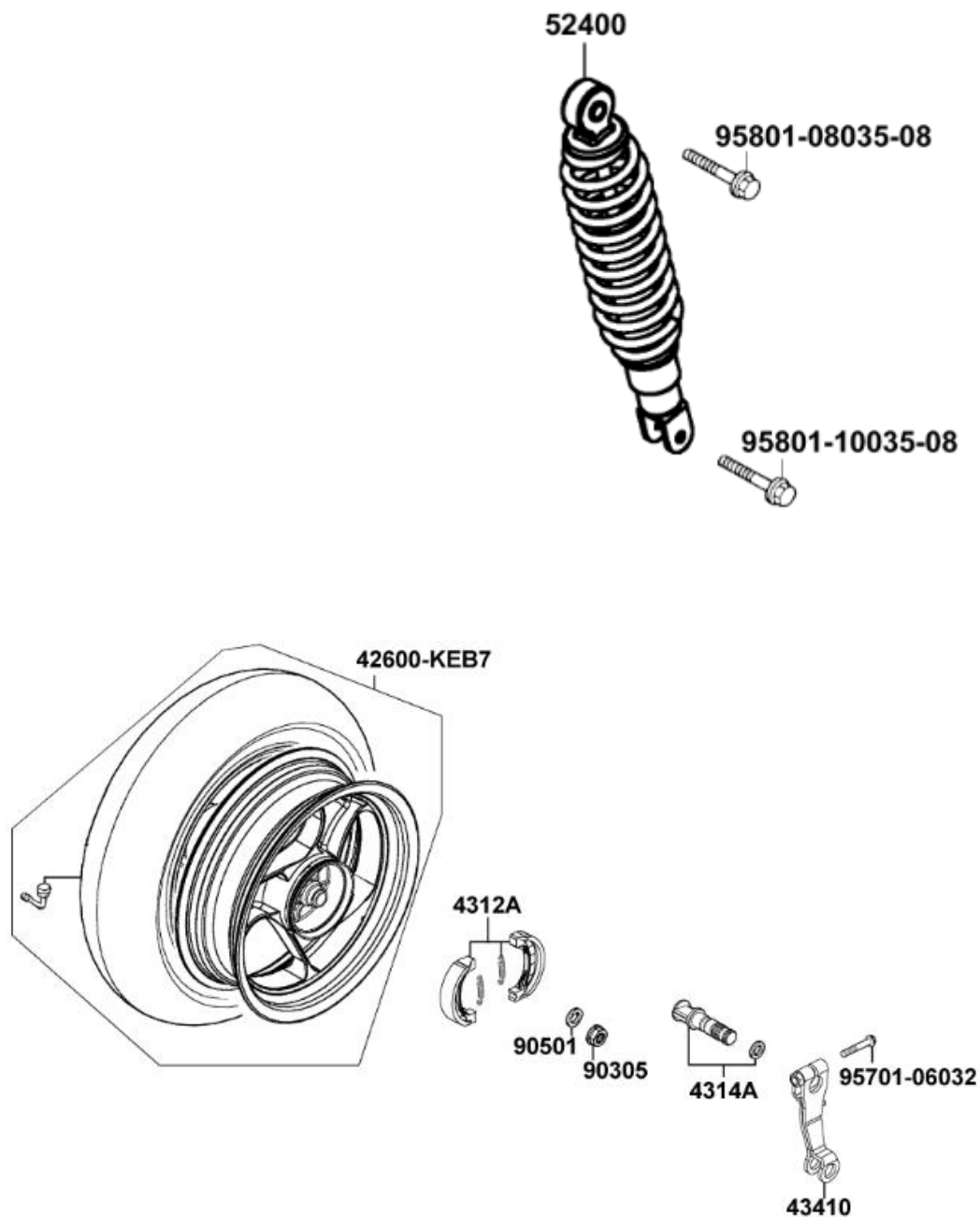

SERVICE INFORMATION	13-1	REAR BRAKE.....	13-3
TROUBLESHOOTING	13-1	REAR SHOCK ABSORBER.....	13-4
REAR WHEEL	13-2		

SERVICE INFORMATION

GENERAL INSTRUCTIONS

- During servicing, keep oil or grease off the brake drum and brake linings.

SPECIFICATIONS

Item		Standard (mm)	Service Limit (mm)
Rear wheel	Rim runout	Radial	—
		Axial	—
	Rear brake drum I.D		110
Rear brake lining thickness		4.0	2.0
Rear shock absorber spring free length		227	220

TORQUE VALUES

Rear axle nut	11~13kgf-m
Rear shock absorber upper mount bolt	3.5~4.5kgf-m
Rear shock absorber lower mount bolt	2.4~3.0kgf-m
Exhaust muffler joint lock nut	1.0~1.4kgf-m
Exhaust muffler lock bolt	3.0~3.6kgf-m

Special Tool

Cushion Assemble & Disassemble Tool

TROUBLESHOOTING

Rear wheel wobbling

- Bent rim
- Faulty tire
- Axle not tightened properly

Soft rear shock absorber

- Weak shock absorber spring
- Faulty damper

Poor brake performance

- Brake not adjusted properly
- Worn brake linings
- Worn brake shoes at cam contacting area
- Worn brake cam
- Worn brake drum

13. REAR WHEEL/REAR BRAKE/ REAR SUSPENSION

REAR WHEEL

REMOVAL

- Remove the exhaust muffler. (⇒2-5)
- Remove the rear axle nut.
- Remove the rear wheel.



Rear Axle Nut

INSPECTION

Measure the rear wheel rim runout.

Service Limits:

Radial: 2.0mm replace if over

Axial: 2.0mm replace if over

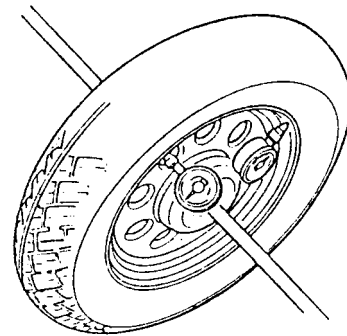

Inspect the rear brake drum.

Measure the rear brake drum I.D.

Service Limits: 130mm replace if over

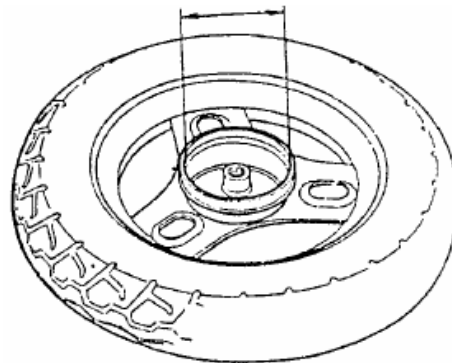

INSTALLATION

Install the rear wheel in the reverse order of removal.

Tighten the rear axle nut.

Torque: 11.0-13.0kgf-m

Install the exhaust muffler.

Torque:

Exhaust muffler joint lock nut: 1.0~1.4kgf-m

Exhaust muffler lock bolt: 3.0~3.6kgf-m

* First install and tighten the exhaust muffler joint lock nuts and then the exhaust muffler lock bolts.



13. REAR WHEEL/REAR BRAKE/ REAR SUSPENSION

REAR BRAKE

BRAKE LINING INSPECTION

Measure the brake lining thickness.

Service Limit: 2.0mm replace if below

* Keep oil or grease off the brake linings.

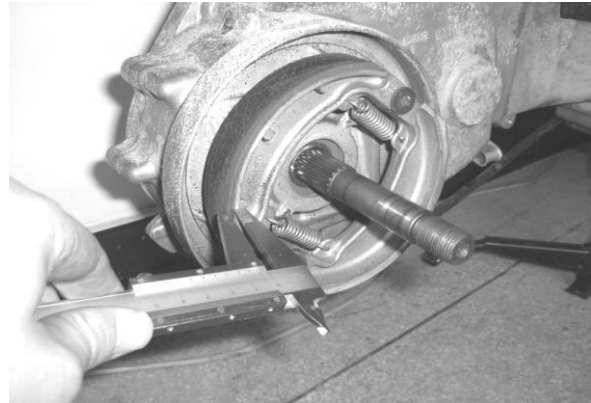

REAR BRAKE DISASSEMBLY

Remove the rear brake adjusting nut and disconnect the rear brake cable.
Remove the rear brake shoes.

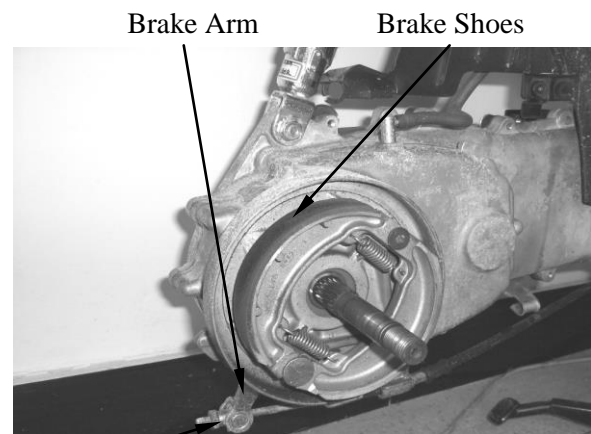

Remove the brake arm bolt to remove the brake arm.
Remove the brake cam.

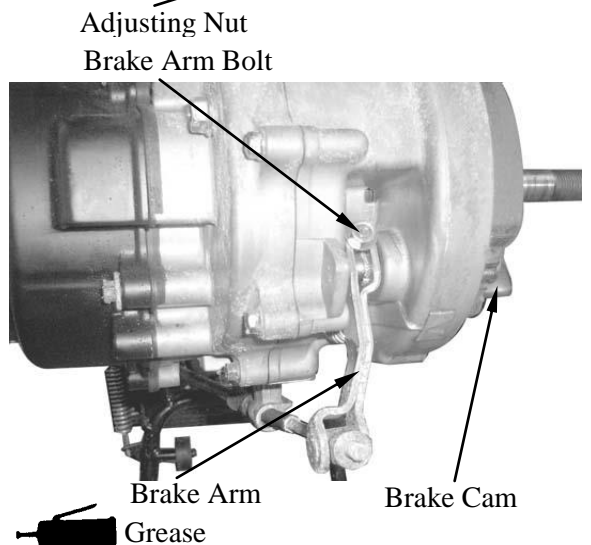

REAR BRAKE ASSEMBLY

Apply grease to the anchor pin.
Apply grease to the brake cam and install it.
Install the brake shoes.

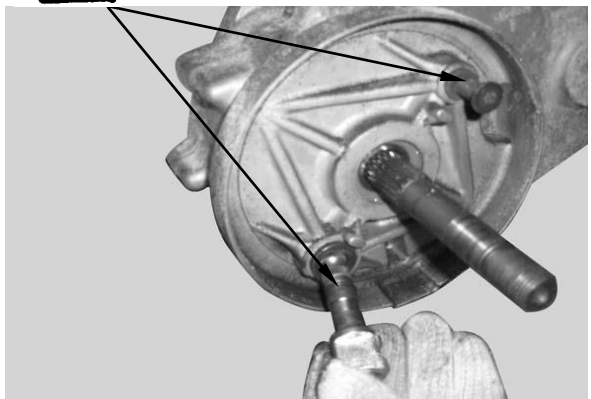

13. REAR WHEEL/REAR BRAKE/ REAR SUSPENSION

Apply a small amount of engine oil to the felt seal and install it to the brake cam.
Install the brake arm.

* Align the wide groove on the wear indicator plate with the wide tooth of the brake cam.

Install and tighten the brake arm bolt.

* Align the scribed line on the brake arm with the punch mark on the brake cam.

Install the brake arm return spring.
Install the brake arm pin.
Connect the brake cable and install the adjusting nut.
Install the rear wheel. (⇒13-2)
Adjust the rear brake lever free play. (⇒3-8)

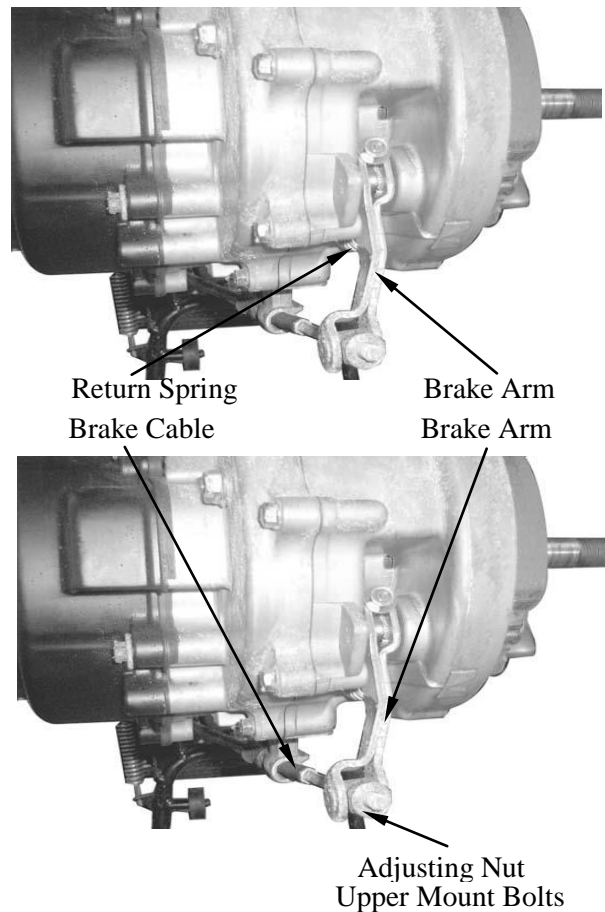

LEFT REAR SHOCK ABSORBER REMOVAL

Remove the frame body cover. (⇒2-3)
Remove the air cleaner case. (⇒5-19)

Remove the rear shock absorber upper and lower mount bolts.
Remove the rear shock absorber.

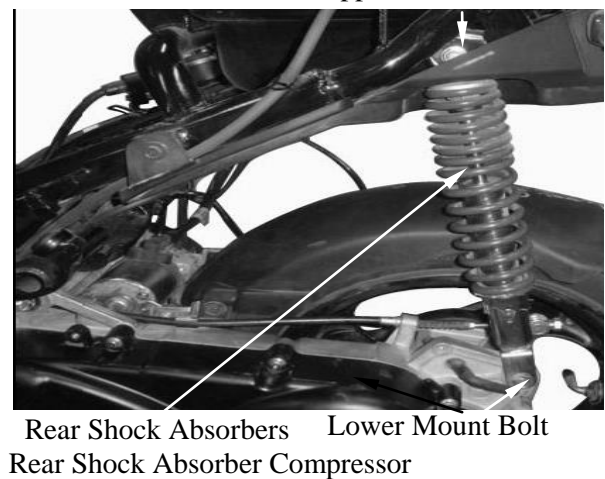

DISASSEMBLY

Install the rear shock absorber compressor as the figure shown.

* Install the rear shock absorber lower joint into the rear shock absorber compressor.

Compress the rear shock absorber spring.

Special

Cushion Assemble & Disassemble Tool

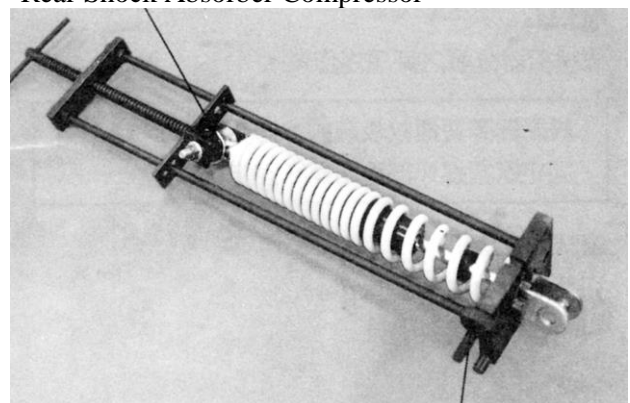

Cushion Assemble & Disassemble Tool

13. REAR WHEEL/REAR BRAKE/ REAR SUSPENSION

INSPECTION

Inspect the damper rod for bending or damage.
Inspect the damper for oil leaks.
Inspect the damper rubber for deterioration or damage.

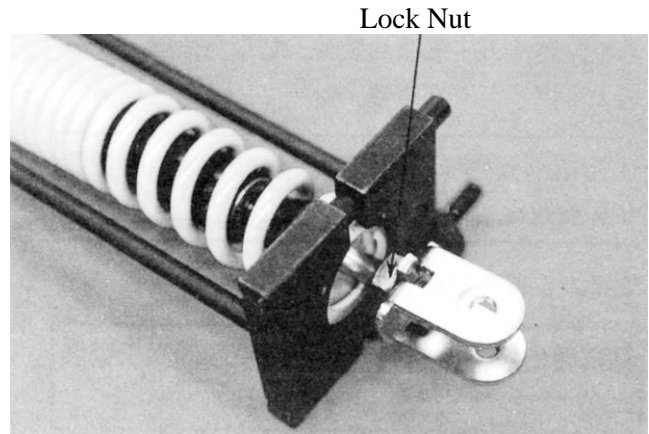

Measure the rear shock absorber spring free length.

Service Limit: 210mm replace if over

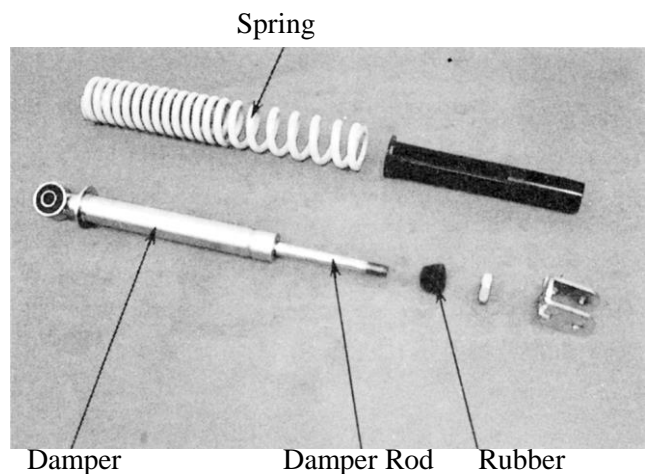

ASSEMBLY

Assemble the rear shock absorbers in the reverse order of disassembly.

- * Install the shock absorber spring with loosely wound coils facing down.
- * Apply locking agent to the lock nut threads and tighten the lock nut.

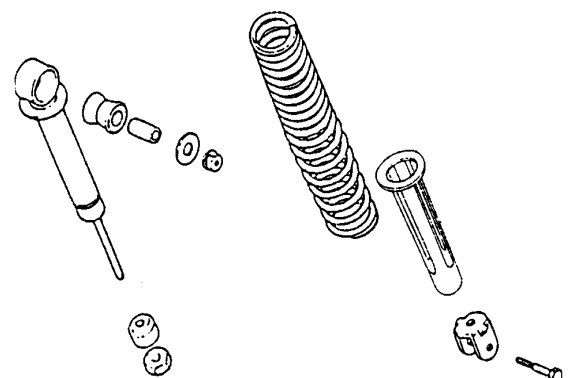
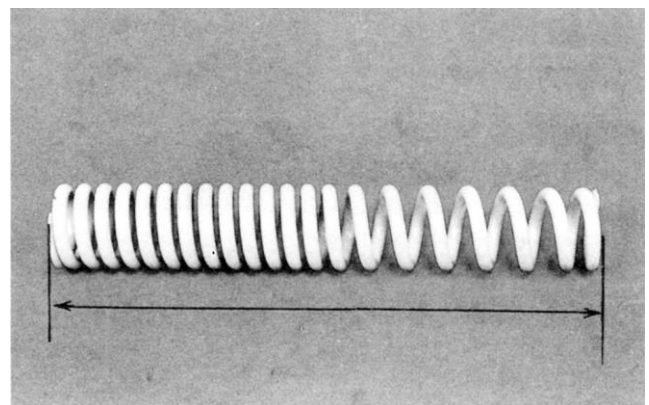

13. REAR WHEEL/REAR BRAKE/ REAR SUSPENSION

INSTALLATION

Install the rear shock absorber.
Install the rear shock absorber upper mount bolt and then the lower mount bolt.
Tighten the bolts.

Torque:

Upper Mount Bolt: 3.5~4.5kgf-m

Lower Mount Bolt: 2.4~3.0kgf-m

Install the air cleaner case. (⇒5-15)

Install the frame body cover. (⇒2-3)

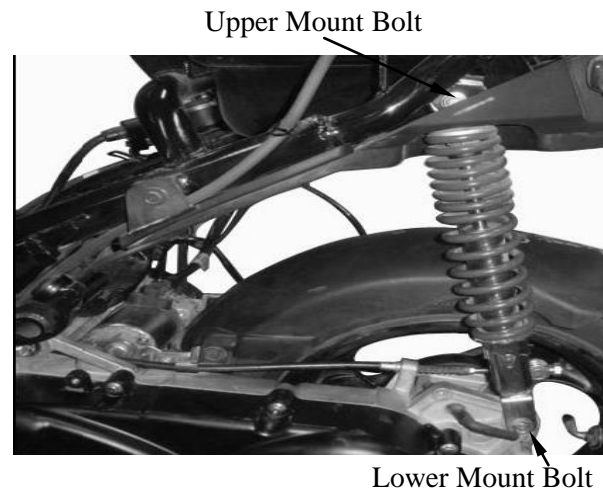

14. BATTERY/CHARGING SYSTEM/ A.C. GENERATOR

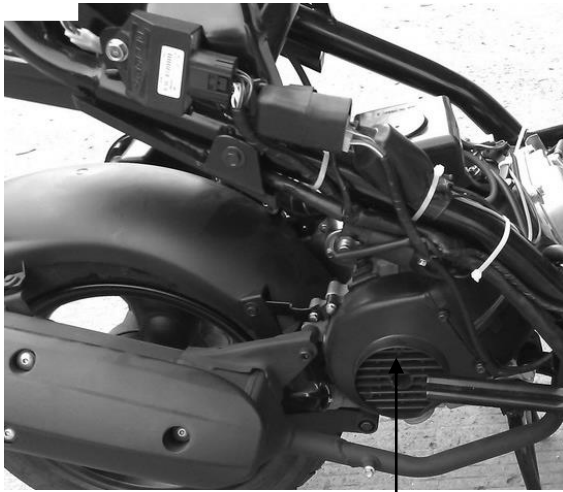

A.C. Generator



Regulator/Rectifier

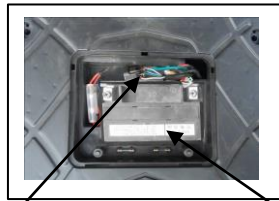

Battery

Diagnostic tool connector

14

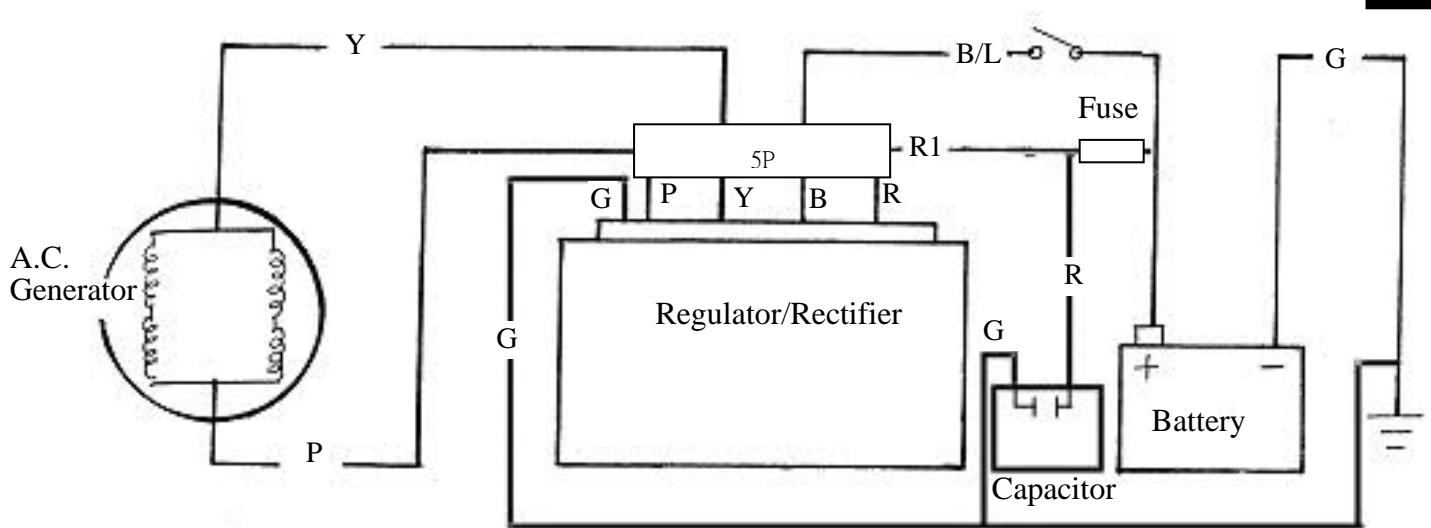

SERVICE INFORMATION.....	14-1	A.C. GENERATOR CHARGING COIL....	14-6
TROUBLESHOOTING	14-2	RESISTOR INSPECTION.....	14-6
BATTERY.....	14-3	A.C. GENERATOR REMOVAL	14-6
CHARGING SYSTEM	14-4	A.C. GENERATOR INATALLATION....	14-8
REGULATOR/RECTIFIER.....	14-5		

SERVICE INFORMATION

GENERAL INSTRUCTIONS



The battery electrolyte (sulfuric acid) is poisonous and may seriously damage the skin and eyes. Avoid contact with skin, eyes, or clothing. In case of contact, flush with water and get prompt medical attention

- The battery can be charged and discharged repeatedly. If a discharged battery is not used for a long time, its service life will be shortened. Generally, the capacity of a battery will decrease after it is used for 2~3 years. A capacity-decreased battery will resume its voltage after it is recharged but its voltage decreases suddenly and then increases when a load is added.
- When a battery is overcharged, some symptoms can be found. If there is a short circuit inside the battery, no voltage is produced on the battery terminals. If the rectifier won't operate, the voltage will become too high and shorten the battery service life.
- If a battery is not used for a long time, it will discharge by itself and should be recharged every 3 months.
- A new battery filled with electrolyte will generate voltage within a certain time and it should be recharged when the capacity is insufficient. Recharging a new battery will prolong its service life.
- Inspect the charging system according to the sequence specified in the Troubleshooting.
- Do not disconnect and soon reconnect the power of any electrical equipment because the electronic parts in the regulator/rectifier will be damaged. Turn off the ignition switch before operation.
- It is not necessary to check the MF battery electrolyte or fill with distilled water.
- Check the load of the whole charging system.
- Do not quick charge the battery. Quick charging should only be done in an emergency.
- Remove the battery from the motorcycle for charging.
- When replacing the battery, do not use a traditional battery.
- When charging, check the voltage with a voltmeter.

14. BATTERY/CHARGING SYSTEM/ A.C. GENERATOR

SPECIFICATIONS

Item		Standard	
Battery	Capacity/Model	12V-6AH	
	Voltage (20°C)	Fully charged	13.1V
		Undercharged	12.3V
	Charging current	STD: 0.4A Quick: 4.0A	
	Charging time	STD: 5~10hr Quick: 30min	
A.C. Generator	Capacity	0.144KW/5000rpm	
	Charging coil resistance (20°C)	Yellow~Peach 0.1~1.0Ω	
Regulator/Rectifier	Type	Single-phase full-wave SCR	
	Limit voltage		
		Charging	14.5±0.5V/5000rpm
Resistor	Resistance (20°C)	5W5Ω	

TORQUE VALUES

Pulser coil bolt	0.45~0.6kgf-m
Stator bolt	0.8~1.2kgf-m
Flywheel nut	3.5~4.5kgf-m
Cooling fan bolt	0.8~1.2kgf-m

SPECIAL TOOLS

Universal holder
Flywheel puller

TESTING INSTRUMENTS

Kowa electric tester
Sanwa electric tester

TROUBLESHOOTING

No power

- Dead battery
- Disconnected battery cable
- Fuse burned out
- Faulty ignition switch

Low power

- Weak battery
- Loose battery connection
- Charging system failure
- Faulty regulator/rectifier

Intermittent power

- Loose battery cable connection
- Loose charging system connection
- Loose connection or short circuit in lighting system

Charging system failure

- Loose, broken or shorted wire or connector
- Faulty regulator/rectifier
- Faulty A.C. generator

BATTERY

REMOVAL

Remove the battery cover screws on the floor board.
Open the battery cover and remove the battery by removing the bolt and band.
First disconnect the battery negative (-) cable and then the positive (+) cable.

When disconnecting the battery positive (+) cable, do not touch the frame with tool; otherwise it will cause short circuit and sparks to fire the fuel.

The installation sequence is the reverse of removal.

First connect the positive (+) cable and the negative (-) cable to avoid short circuit.

BATTERY VOLTAGE (OPEN CIRCUIT VOLTAGE) INSPECTION

Remove the floor board.
Open the battery cover and disconnect the battery cables.
Measure the voltage between the battery terminals.
Fully charged : 13.1V
Undercharged: 12.3V max.

* Battery charging inspection must be performed with a voltmeter.

CHARGING

Connect the charger positive (+) cable to the battery positive (+) terminal.
Connect the charger negative (-) cable to the battery negative (-) terminal.

• Keep flames and sparks away from a charging battery.
• Turn power ON/OFF at the charger, not at the battery terminals to prevent sparks near the battery to avoid explosion.
• Charge the battery according to the current specified on the battery.

* • Quick charging should only be done in an emergency.
• Measure the voltage 30 minutes after the battery is charged.

Charging current: Standard : 0.4A
Quick : 4A

Charging time : Standard : 5~10 hours
Quick : 30 minutes

After charging: Open circuit voltage: 12.8V min.

Note: The battery temperature should not exceed 45°C during charging.

Battery Cover

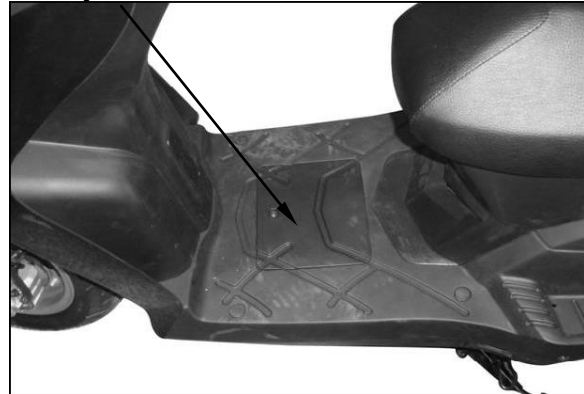

battery



negative (-) cable

positive (+) cable

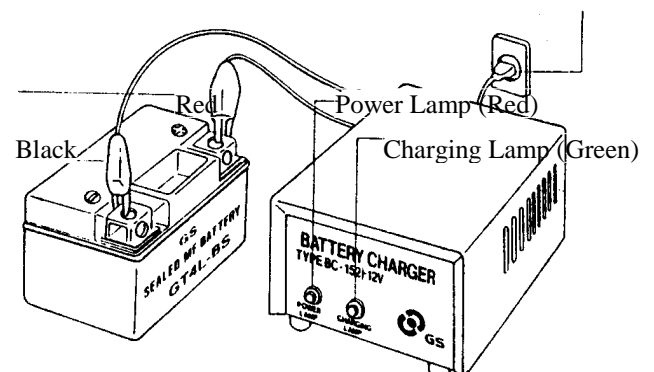
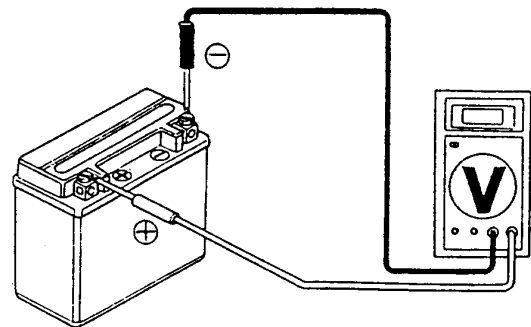

CHARGING SYSTEM

SHORT CIRCUIT TEST

Disconnect the ground wire from the battery and connect an ammeter across the battery negative (-) terminal and the ground wire. Turn the ignition switch OFF and check for short circuit.

* Connect the electric tester positive (+) terminal to ground wire and the tester negative (-) terminal to the battery negative (-) terminal.

If any abnormality is found, check the ignition switch and wire harness for short circuit .

CURRENT TEST

This inspection must be performed with an electric tester when the battery is fully charged.

Warm up the engine for inspection.

Connect the electric tester across the battery terminals. Disconnect the fuse and connect an ammeter between the fuse terminals.

Attach a tachometer to the engine.

Start the engine and gradually increase the engine speed to measure the limit voltage and current.

Limit Voltage/Current: 14~15V/0.5A max.
(5000rpm max.)

If the limit voltage is not within the specified range, check the regulator/rectifier. (⇒14-5)

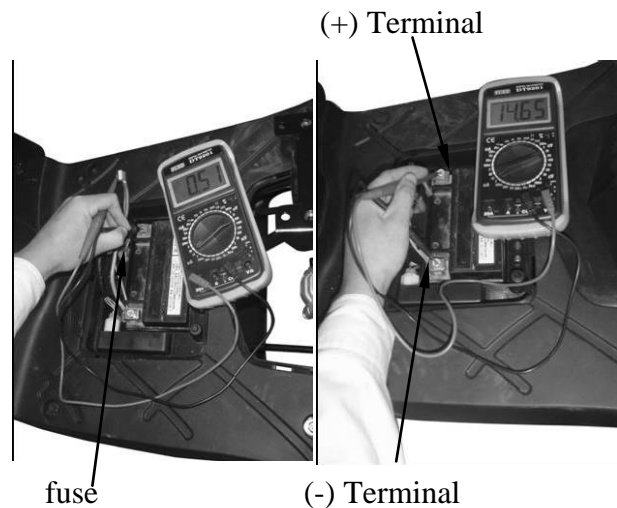
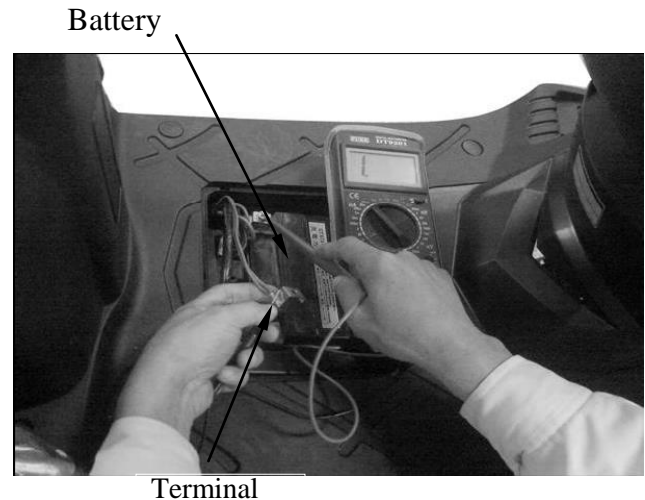

14. BATTERY/CHARGING SYSTEM/ A.C. GENERATOR



AGILITY 50

REGULATOR/RECTIFIER

MAIN HARNESS CIRCUIT INSPECTION

Remove the front covers. (⇒2-2)
Remove the regulator/rectifier 4P coupler and check for continuity between the wire harness terminals according to the following :

Item (Wire Color)	Judgment
Between battery (red) and engine ground	Battery has voltage
Between ground (green) and engine ground	Continuity exists
Between c.d.i wire (black/blue) and engine ground (Remove the auto bystarter coupler and turn the lighting switch OFF for inspection)	A.C. generator stator nought resistance
Between charging coil (yellow or peach) and engine ground	A.C. generator stator nought resistance

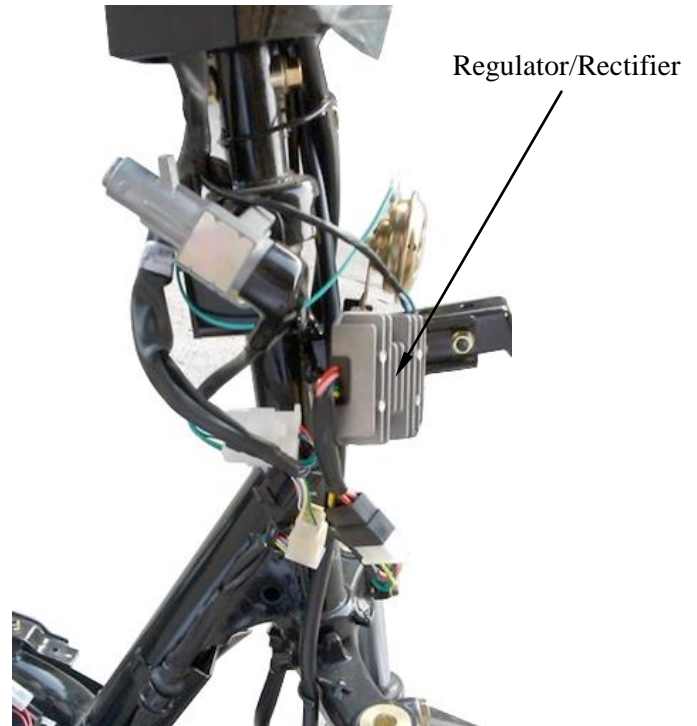

REGULATOR/RECTIFIER

REMOVAL

Remove the regulator/rectifier lock nut and disconnect the regulator/rectifier wire coupler.
Measure the resistances between the regulator/rectifier wire terminals. Replace the regulator/rectifier if the readings are not within the specifications in the table below.

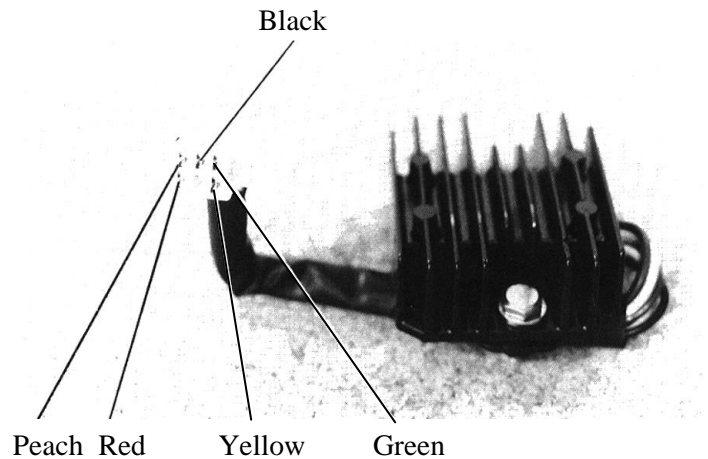

- ***
- Due to the semiconductor in circuit, it is necessary to use a specified tester for accurate testing. Use of an improper tester or measurements in an improper range may give false readings.
 - Use a Sanwa Electric Tester or Kowa Electric Tester for testing.

Testing Range

Range for the Sanwa Tester: xKΩ
Range for the Kowa Tester: x100Ω

(+)Probe \ (-)Probe	Peach	Yellow	Red	Green	Black
Peach		∞	4-7K	∞	∞
Yellow	∞		4-7K	∞	∞
Red	∞	∞		∞	∞
Green	4-6K	4-6K	13-17K		1-2K
Black	4-7K	4-7K	13-17K	1-2K	

A.C. GENERATOR CHARGING COIL

* The inspection of A.C. generator charging coil can be made with the engine installed.

INSPECTION

Disconnect the A.C. generator 2P connector. Measure the resistance between the A.C. generator white wire and engine ground with an electric tester.

Standard: 0.1 ~ 1.0Ω(at 20°C)

Replace the A.C. generator charging coil if the reading is not within the specifications.

Charging Coil Wire



A.C. GENERATOR

REMOVAL

Remove the right side cover. (⇒2-4)
Remove the four bolts attaching the cooling fan cover to remove the fan cover.

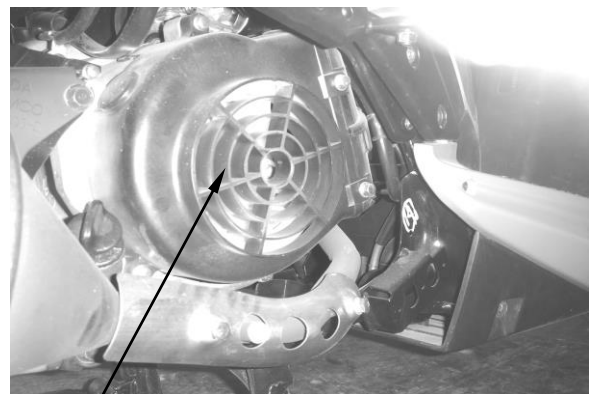

Fan Cover

14. BATTERY/CHARGING SYSTEM/ A.C. GENERATOR

Remove the cooling fan by removing the four cooling fan attaching bolts.

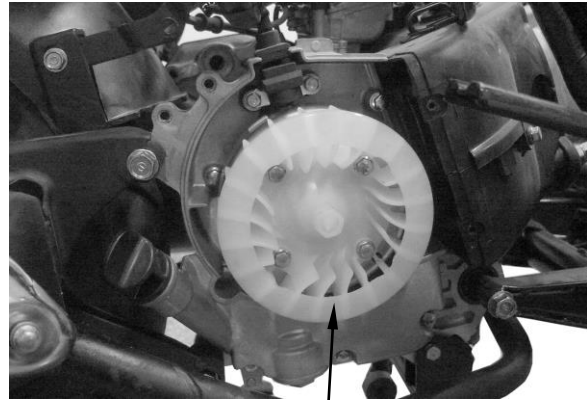

Cooling Fan

Hold the flywheel with an universal holder.
Remove the flywheel nut.

Special

Universal Holder

Universal Holder

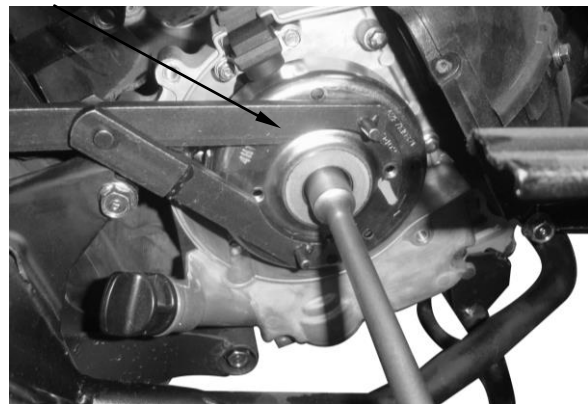

Remove the A.C. generator flywheel using the flywheel puller.
Remove the woodruff key.

Special

Flywheel Puller

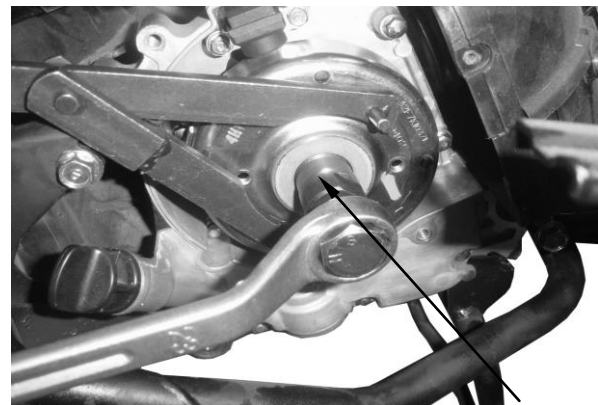

Flywheel Puller

Remove the A.C. generator wire connector.

A.C. Generator Wire Connector



14. BATTERY/CHARGING SYSTEM/ A.C. GENERATOR

Remove the A.C. generator wire set plate.
Remove the pulser coil bolts.
Remove the A.C. generator wire rubber sleeve and pulser coil from the right crankcase.
Remove the two bolts and A.C. generator stator.

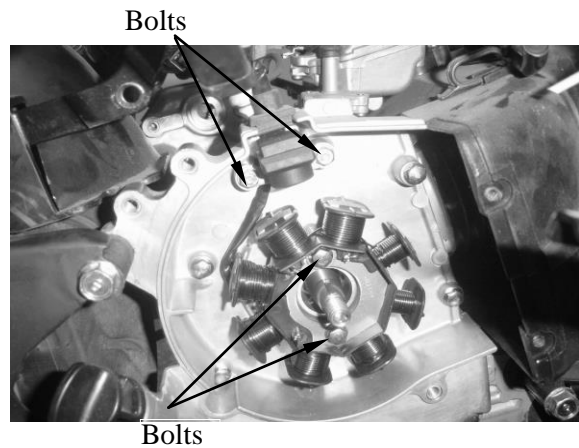

A.C. GENERATOR INSTALLATION

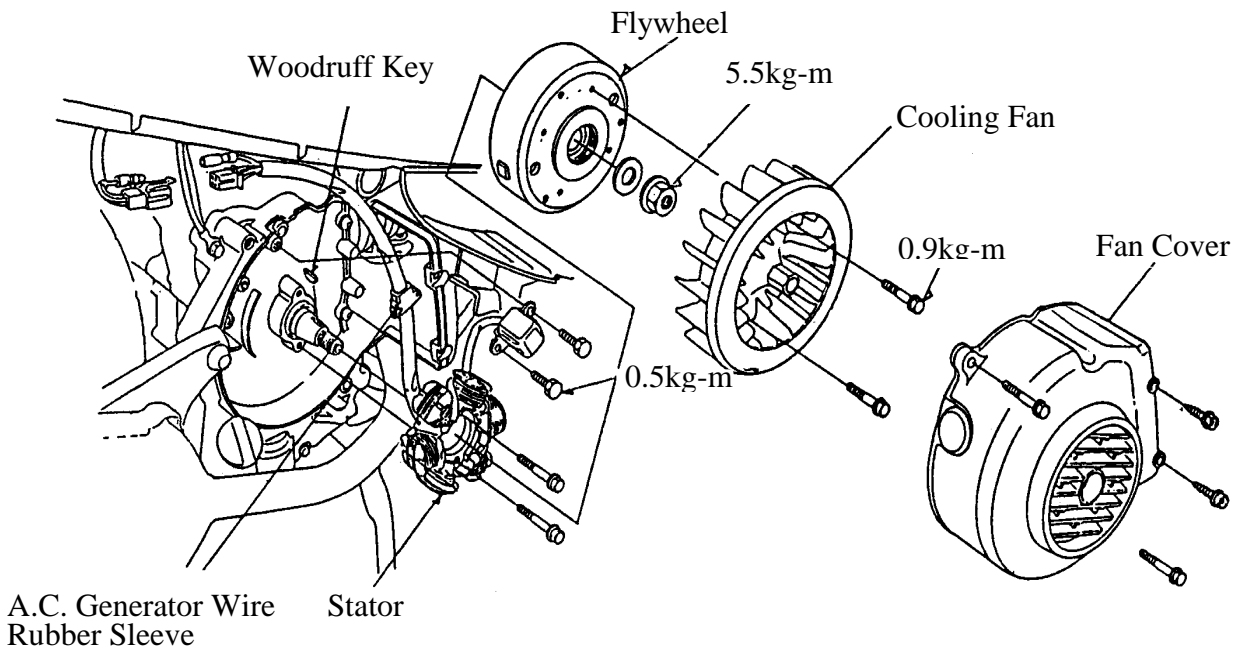

Install the A.C. generator stator and pulser coil onto the right crankcase.
Tighten the stator and pulser coil bolts.
Torques: Pulser Coil : 0.45~0.6kgf-m
Stator : 0.8~1.2kgf-m

Install the A.C. generator wire rubber sleeve and A.C. generator wire set plate.

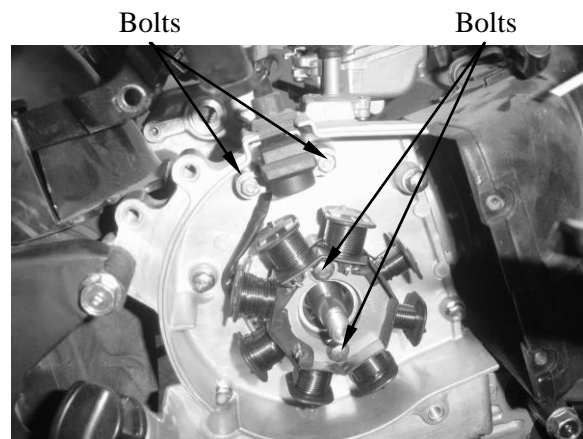

14. BATTERY/CHARGING SYSTEM/ A.C. GENERATOR

Clean the taper hole in the flywheel off any burrs and dirt.
Install the woodruff key in the crankshaft keyway.

A.C. Generator Wire Connector



Install the flywheel onto the crankshaft with the flywheel hole aligned with the crankshaft woodruff key.

* The inside of the flywheel is magnetic. Make sure that there is no bolt or nut before installation.

Woodruff Key

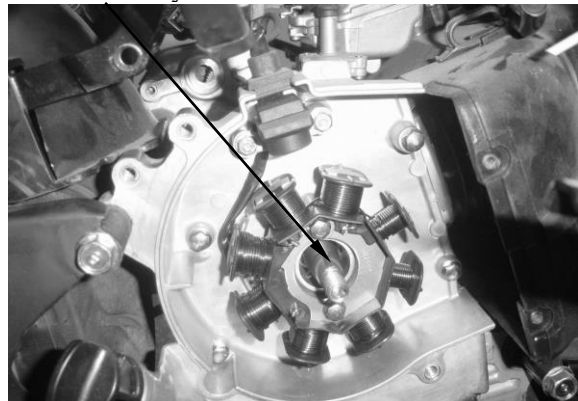

Hold the flywheel with the universal holder and tighten the flywheel nut.

Torque: 3.5~4.5kgf-m

Universal Holder

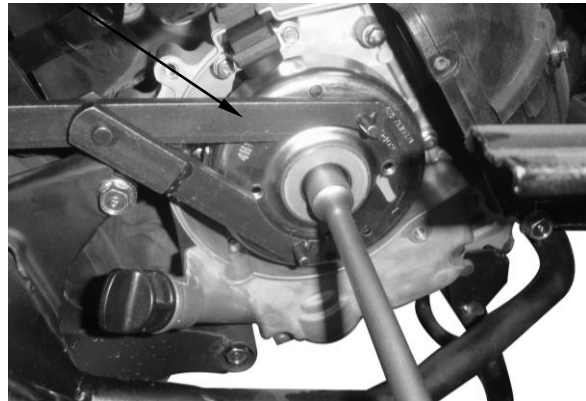

Special

Universal Holder

Install the cooling fan.

Torque: 0.8~1.2kgf-m

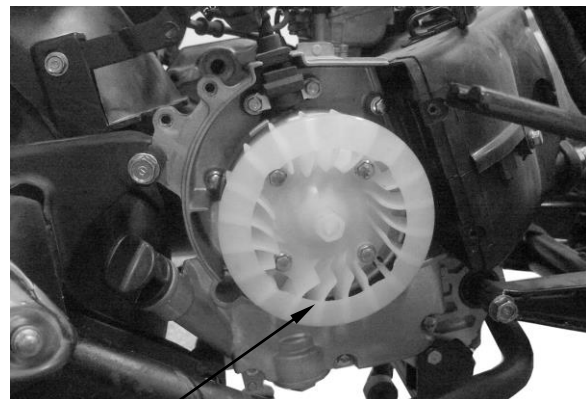

Cooling Fan

14. BATTERY/CHARGING SYSTEM/ A.C. GENERATOR

Install the fan cover.
Install the right side cover. (⇒2-4)



Fan Cover

15. IGNITION SYSTEM

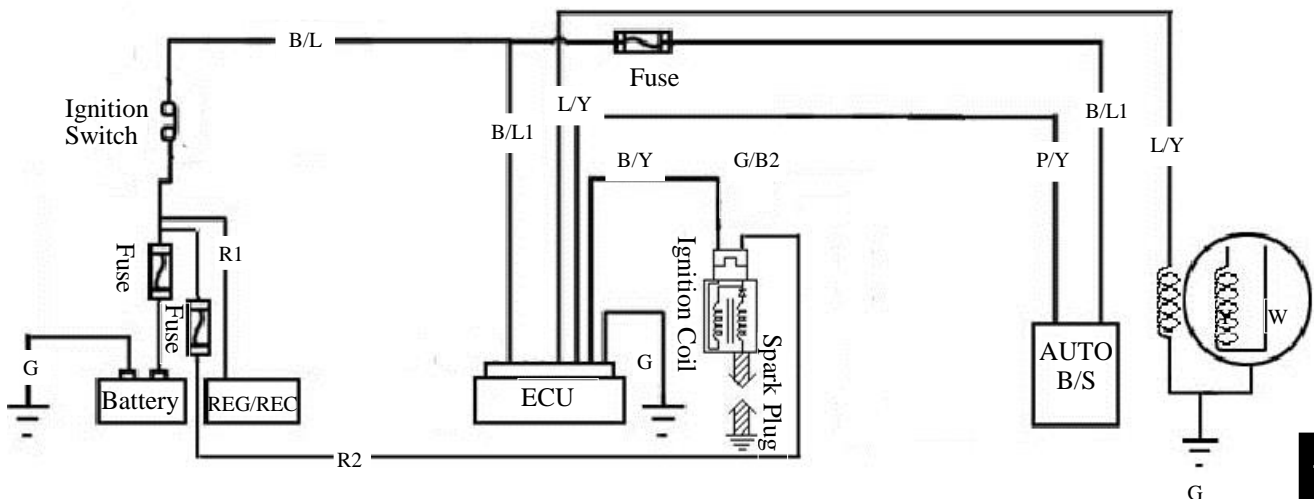
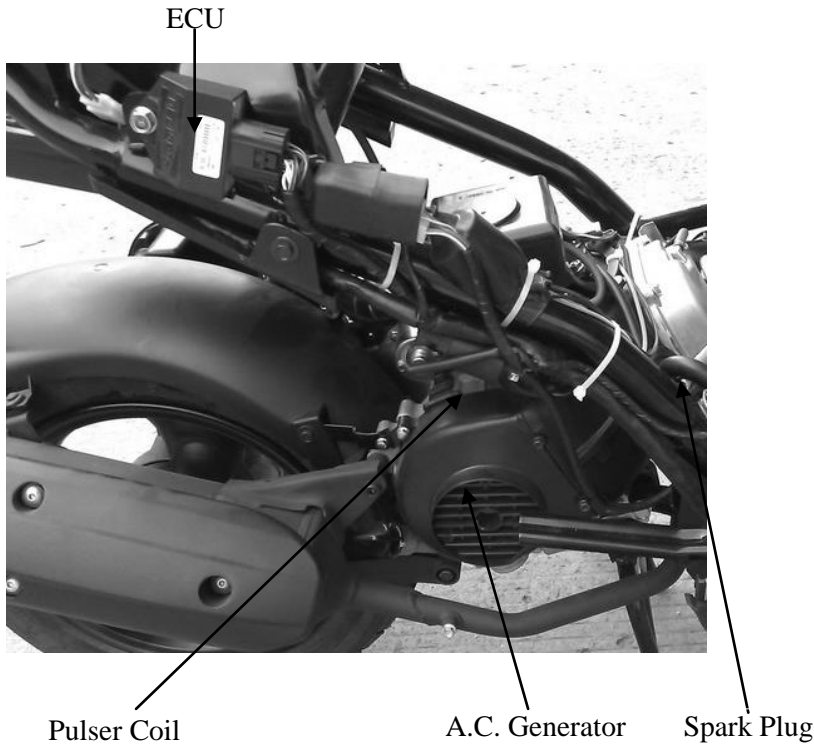

SERVICE INFORMATION.....	15-1	IGNITION COIL	15-4
TROUBLESHOOTING	15-2	PULSER COIL	15-5
CDI UNIT INSPECTION.....	15-3		

SERVICE INFORMATION

GENERAL INSTRUCTIONS

- Check the ignition system according to the sequence specified in the Troubleshooting. (⇒15-2)
- The ignition system adopts ECU and the ignition timing cannot be adjusted.
- If the timing is incorrect, inspect the ECU and A.C. generator and replace any faulty parts.
Inspect the ECU with a ECU tester
- Loose connector and poor wire connection are the main causes of faulty ignition system. Check each connector before operation.
- Use of spark plug with improper heat range is the main cause of poor engine performance.
- The inspections in this section are focused on maximum voltage. The inspection of ignition coil resistance is also described in this section.
- Inspect the ignition switch according to the continuity table specified in page 17-3.
- Inspect the spark plug referring to Section 3.
- Remove the A.C. generator and pulser coil referring to Section 14.

SPECIFICATIONS

Item		Standard	
Spark plug	Standard type	(NGK) CR7HSA	
	Hot type	(NGK) CR6HSA	
	Cold type	(NGK) CR8HSA	
Spark plug gap		0.6~0.7mm	
Ignition timing	“F” mark	12° BTDC /2000rpm±100RPM	
	Full advance	25° BTDC /5000rpm±100RPM	
Ignition coil resistance (20°C)	Primary coil		0.1~1.0Ω
	Secondary coil	with plug cap	7~12KΩ
		without plug cap	3~5KΩ
Pulser coil resistance (20°C)		40~300Ω	
Ignition coil primary side max. voltage		12V min.	
Pulser coil max. voltage		2.1V min.	

TESTING INSTRUMENT

Kowa Electric Tester

or commercially available electric tester with resistance over 10MΩ/CDV

15. IGNITION SYSTEM

TROUBLESHOOTING

High voltage too low

- Weak battery or low engine speed
- Loose ignition system connection
- Faulty ignition coil
- Faulty ECU
- Faulty pulser coil

Intermittent high voltage

- Faulty ignition switch
- Poorly connected ECU coupler
- Poorly connected or broken ECU ground wire
- Faulty pulser coil
- Loose high tension wire connection
- Faulty ECU

Normal high voltage but no spark at plug

- Faulty spark plug
- Faulty spark plug cap

No high voltage

- Faulty ignition switch
- Dead battery or faulty regulator/rectifier
- Faulty charging circuit
- Faulty ignition coil
- Faulty ECU

No or intermittent high voltage

- Faulty ignition coil
- Weak battery
- Faulty charging system

15. IGNITION SYSTEM

ECU

ECU is the electronic control unit, and its maximum working voltage to 18 v. ECU is through a 16-bit chip, The speed signal, oxygen sensor signal, engine temperature sensor signal, trigger signal, such as internal control logic processing, realize the ignition coil, solenoid valve, warning lamp etc.



IGNITION COIL REMOVAL

Remove the met-in box. (⇒2-3)
Remove the spark plug cap.
Disconnect the ignition coil wires and remove the ignition coil bolt and ignition coil.



Ignition Coil

INSPECTION CONTINUITY TEST

* The ECU is not adjustable. If the timing is incorrect, inspect the ECU, pulser coil and A.C. generator and replace any faulty parts.

Measure the resistance between the ignition coil primary coil terminals.

Resistance: 0.1 ~ 1.0Ω

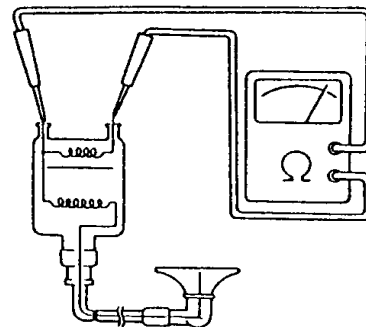

Measure the secondary coil resistances with and without the spark plug cap.

Resistances:

(with plug cap) : 7 ~ 12KΩ

(without plug cap) : 3 ~ 5KΩ

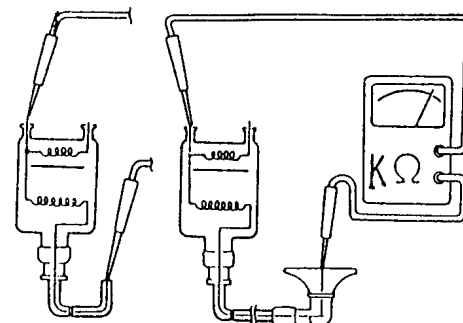

* Correctly operate the tester following the manufacturer's instructions.

15. IGNITION SYSTEM

PULSER COIL INSPECTION

* This test is performed with the stator installed in the engine.

Remove the frame body cover. (⇒2-3)
Disconnect the A.C. generator connector.



Pulser Coil Coupler

Measure the pulser coil resistance between the blue/yellow and green wire terminals.

Resistance: 80~160Ω

Refer to page 14-6 for the A.C. generator removal.

IGNITION TIMING INSPECTION

* The ECU is not adjustable. If the ignition timing is incorrect, inspect the ECU, pulser coil and A.C. generator and replace any faulty parts.

Remove the timing hole cap.

Timing Hole Cap



Warm up the engine and check the ignition timing with a timing light.
When the engine is running at the ignition timing is correct if the “F” mark aligns with the index mark within ±2°.

Ignition Timing: BTDC28°/4000rpm



“F” Mark

16. STARTING SYSTEM

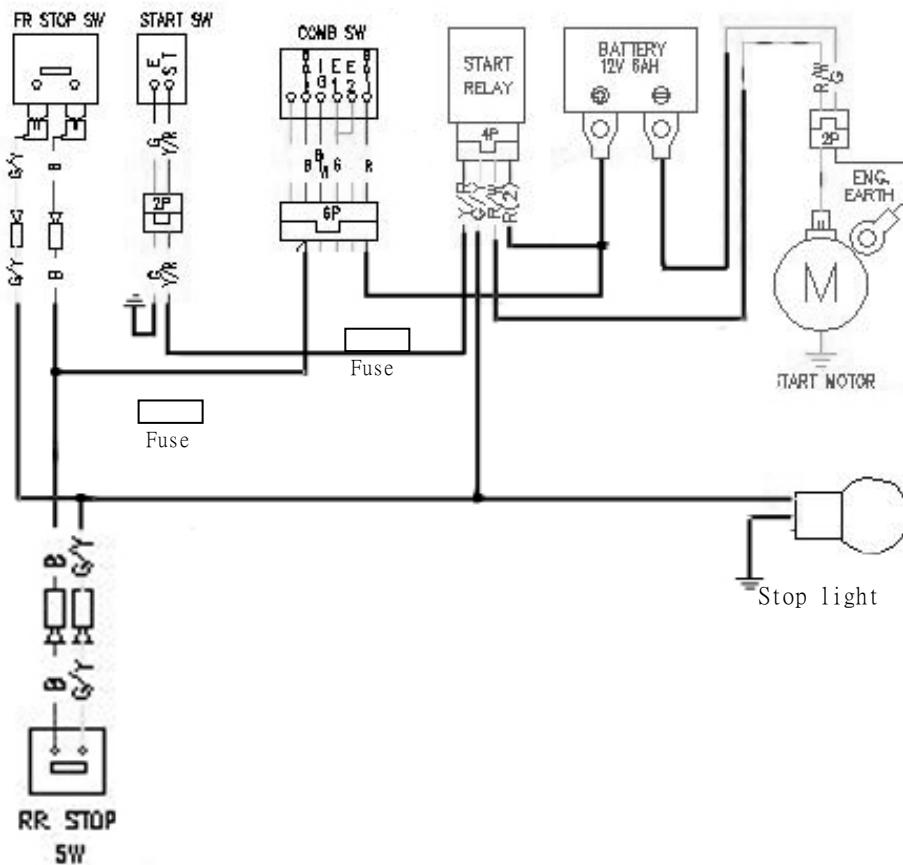

SERVICE INFORMATION	16-1	STARTER MOTOR	16-2
TROUBLESHOOTING.....	16-1	STARTER RELAY.....	16-4

SERVICE INFORMATION

GENERAL INSTRUCTIONS

- The removal of starter motor can be accomplished with the engine installed.

SPECIFICATIONS

Item	Standard (mm)	Service Limit (mm)
Starter motor brush length	12.5	8.5

TROUBLESHOOTING

- Faulty ignition switch
- Faulty starter clutch
- Faulty front or rear stop switch
- Faulty starter relay **Starter motor rotates but engine does**
- Foreign matter stuck in starter motor or gear

Starter motor won't turn

- Fuse burned out
- Weak battery
- Poorly connected, broken or shorted wire
- Faulty starter motor

Lack of power

- Weak battery
- Loose wire or connection

not start

- Faulty starter clutch
- Starter motor rotates reversely
- Weak battery

16. STARTING SYSTEM

STARTER MOTOR

REMOVAL

* Before removing the starter motor, turn the ignition switch OFF and remove the battery ground. Then, turn on the ignition switch and push the starter button to see if the starter motor operates properly.

Remove the front cover.
 Remove the starter motor cable.
 Remove the two starter motor mounting bolts and the motor.

Remove the waterproof rubber jacket and disconnect the starter motor cable connector.

DISASSEMBLY

Remove the two starter motor case screws, front cover, motor case and other parts.

INSPECTION

Inspect the removed parts for wear, damage or discoloration and replace if necessary. Clean the commutator if there is metal powder between the segments.

Check for continuity between pairs of the commutator segments and there should be continuity. Also, make a continuity check between individual commutator segments and the armature shaft. There should be no continuity.

Starter Motor Cable

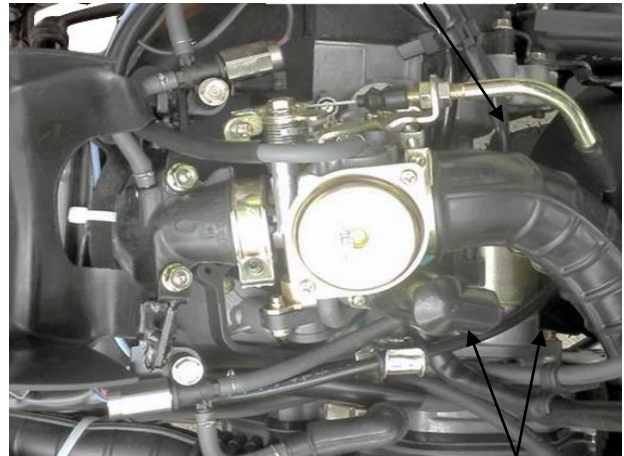

Bolts

Front Cover

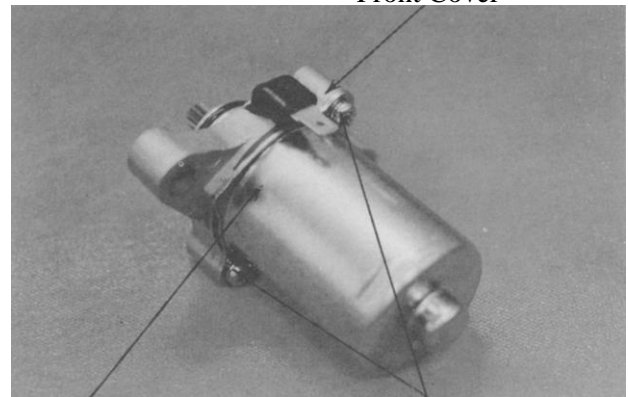

Motor Case

Case Screws

Commutator

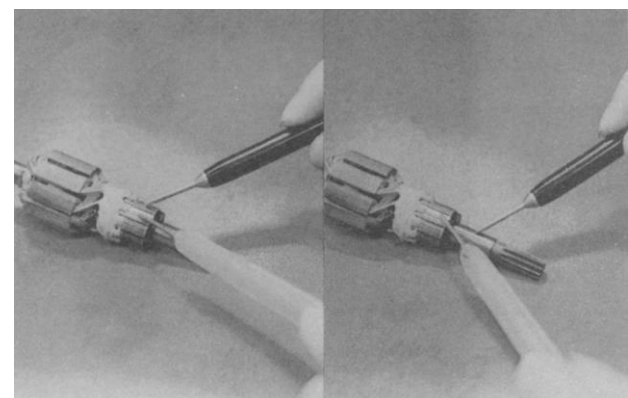
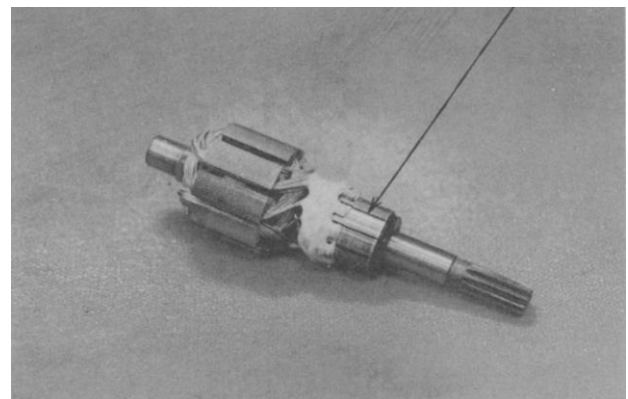

16. STARTING SYSTEM

STARTER MOTOR CASE CONTINUITY CHECK

Check to confirm that there is no continuity between the starter motor wire terminal and the motor front cover.
 Also check for the continuity between the wire terminal and each brush and there should be continuity.
 Replace if necessary.

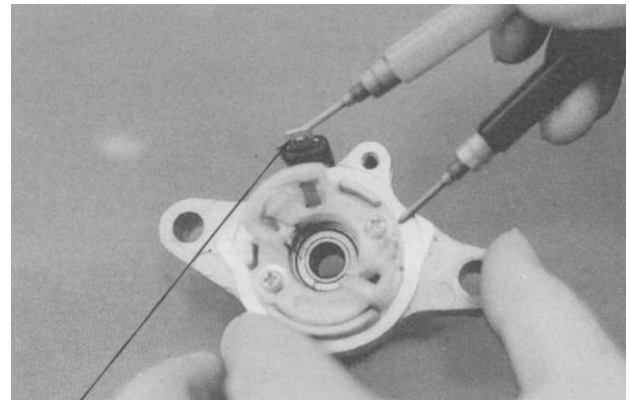

Wire Terminal

Measure the length of the brushes.
Service Limit: 8.5mm replace if below

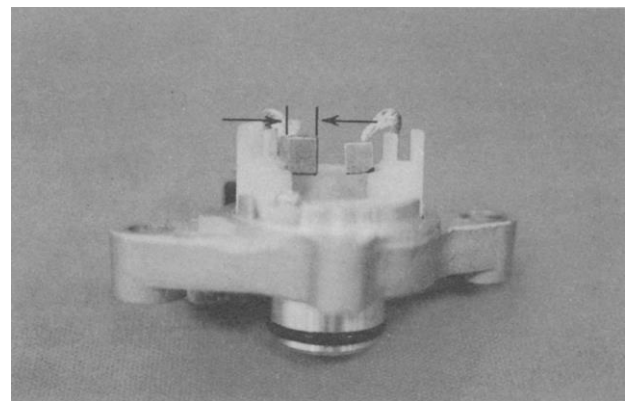

Check for continuity between the brushes. If there is continuity, replace with new ones.

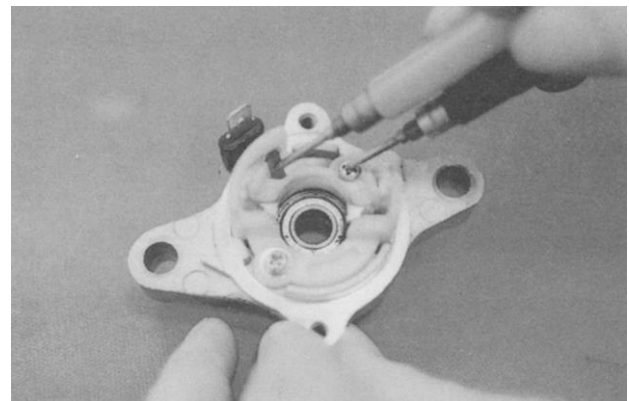

Check if the needle bearing in the front cover turns freely and has no excessive play.
 Replace if necessary.
 Check the dust seal for wear or damage.

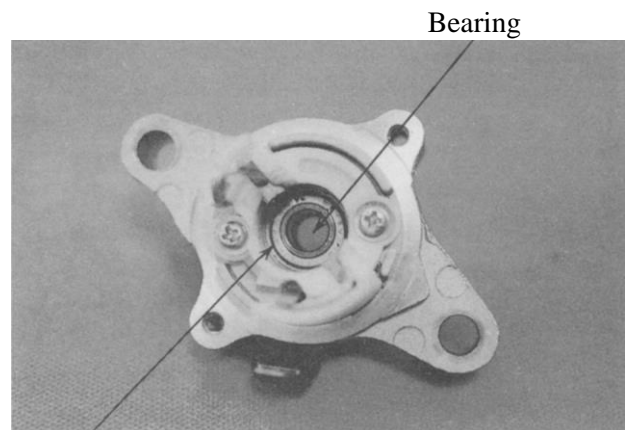

Dust Seal

16. STARTING SYSTEM

ASSEMBLY

Apply grease to the dust seal in the front cover.
 Install the brushes onto the brush holders.
 Apply a thin coat of grease to the two ends of the armature shaft.
 Insert the commutator into the front cover.

- *
 - Be careful not to damage the brush and armature shaft mating surfaces.
 - When installing the commutator, the armature shaft should not damage the dust seal lip.

Install a new O-ring to the front cover.
 Install the starter motor case, aligning the tab on the motor case with the tab on the front cover.
 Tighten the starter motor case screws.

- *
 - When assembling the front cover and motor case, slightly press down the armature shaft to assemble them.

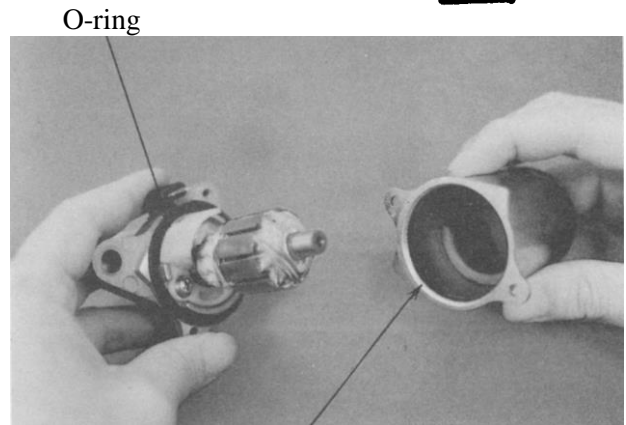
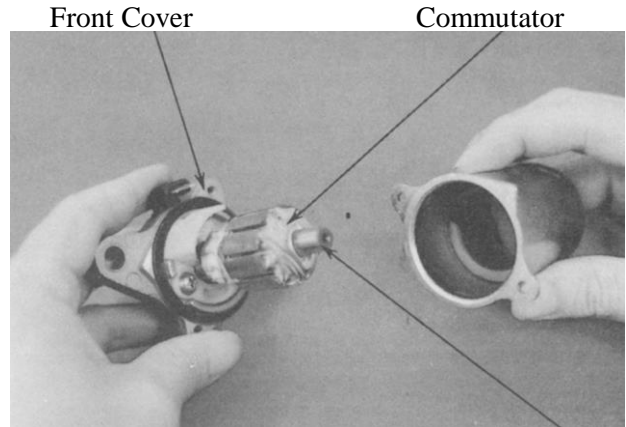

STARTER RELAY

INSPECTION

Remove the met-in box.
 Remove the battery cover.
 Remove the frame body cover. (⇒2-2)
 Turn the ignition switch ON and the starter relay is normal if you hear a click when the starter button is depressed.
 If there is no click sound:

- Inspect the starter relay voltage
- Inspect the starter relay ground circuit
- Inspect the starter relay operation

STARTER RELAY VOLTAGE INSPECTION

Place the motorcycle on its main stand.
 Measure the voltage between the starter relay connector green/yellow wire (-) and engine ground.
 Turn the ignition switch ON and the battery voltage should be normal when the brake lever is fully applied.
 If the battery has no voltage, inspect the stop switch continuity and cable.

- *
 - Turn to the DCV position for the voltage meter, then inspect the starter relay.

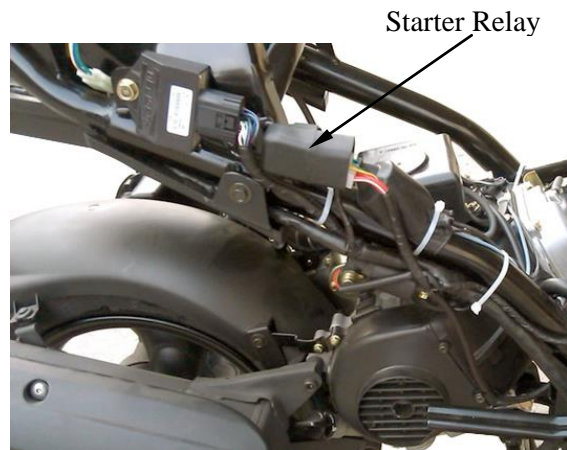

16. STARTING SYSTEM

STARTER RELAY TEST

Remove the battery cover.
 Disconnect the 4P connector from the starter relay and remove the starter relay.



Connect the starter relay (D) terminal to the 12V battery positive (+) terminal and the relay (C) terminal to the battery negative (-) terminal. Check for continuity between the starter relay (A) and (B) terminals. The relay is normal if there is continuity.

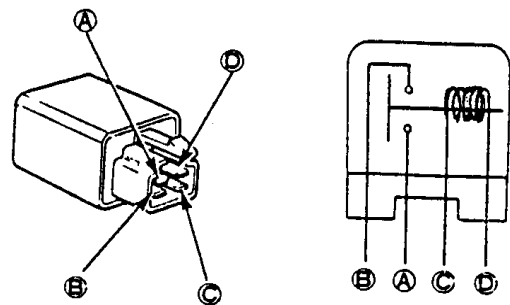

STARTER MOTOR INSTALLATION

Apply engine oil to the starter motor O-ring and install the starter motor.
 Tighten the two mounting bolts.
 Connect the starter motor cable connector.

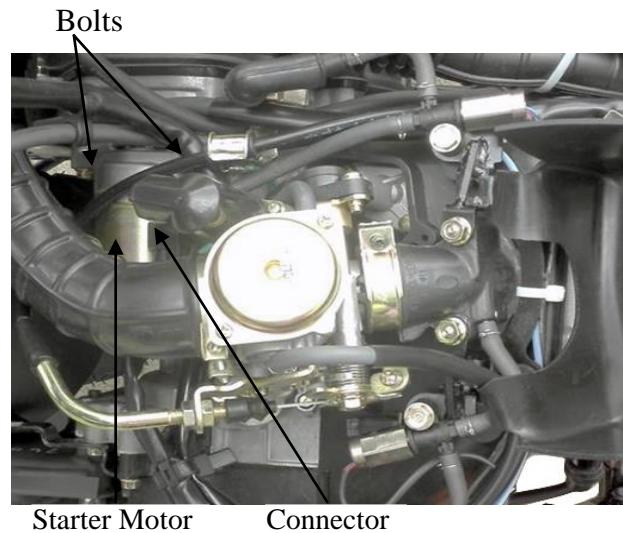

SERVICE INFORMATION	17-0	IGNITION SWITCH	17-3
TROUBLESHOOTING	17-0	STOP SWITCHES/HORN	17-4
FUEL UNIT	17-1	INSTRUMENTS	17-4
HANDLEBAR SWITCHES	17-2	HEADLIGHT/LIGHTS	17-5

SERVICE INFORMATION

GENERAL INSTRUCTIONS

- An electric tester is needed to measure or test the electric equipment.
- Be sure to use fuses and bulbs of the same specifications to avoid damage of electrical equipment.
- After installation of each switch, a continuity check must be performed. A continuity check can usually be made without removing the part from the motorcycle.

TROUBLESHOOTING

Lights do not come on when ignition switch is "ON"

- Burned bulb
- Faulty switch
- Broken wire
- Fuse burned out
- Weak battery
- Poorly connected or shorted wire
- Faulty winker

Light dims

- Faulty ignition coil
- Wire or switch resistance too high
- Faulty regulator/rectifier

Headlight does not change when dimmer switch is turn to Hi or Lo

- Faulty or burned bulb
- Faulty dimmer switch

Fuel gauge pointer does not register correctly

- Disconnected wire or connector
- Broken wire
- Faulty float
- Faulty fuel unit
- Faulty instrument

Fuel gauge pointer fluctuates or swings

- Loose wire connection
- Faulty fuel unit
- Faulty instrument

FUEL UNIT

* No Smoking!

REMOVAL

Remove the met-in box. (⇒2-3)
 Remove the frame right side cover. (⇒2-4)
 Disconnect the fuel unit wire connector.
 Turn the fuel unit retainer counterclockwise to remove it.

* Do not damage the fuel unit wire.

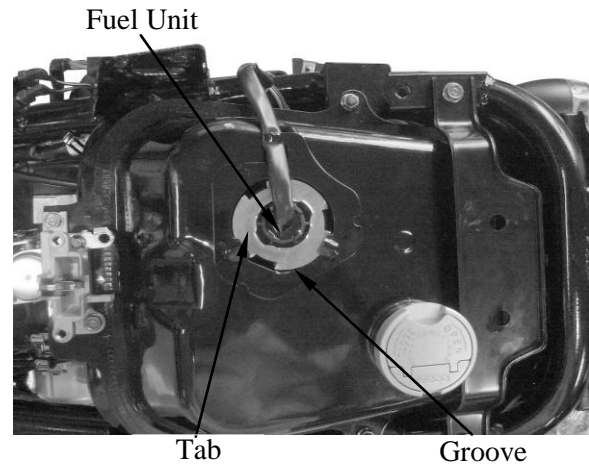

Remove the fuel unit.

* Be careful not to bend or damage the fuel unit float arm.

INSTALLATION

The installation sequence is the reverse of removal.

*

- Align the groove on the fuel unit with the tab on the fuel tank.
- Align the arrow on the retainer with the arrow on the fuel tank.
- Turn the retainer clockwise to secure it.

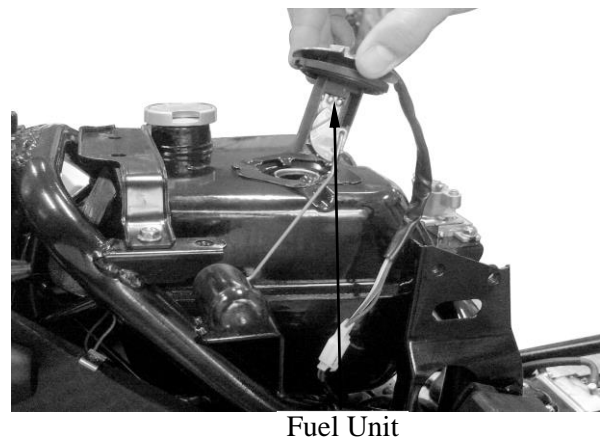

INSPECTION

Remove the fuel unit.
 Measure the resistance between the fuel unit wire terminals with the float at upper and lower positions.

Wire Terminals	Upper	Lower
G~Y/W	30Ω	686Ω
G~L/W	566Ω	153Ω
Y/W~L/W	599Ω	599Ω

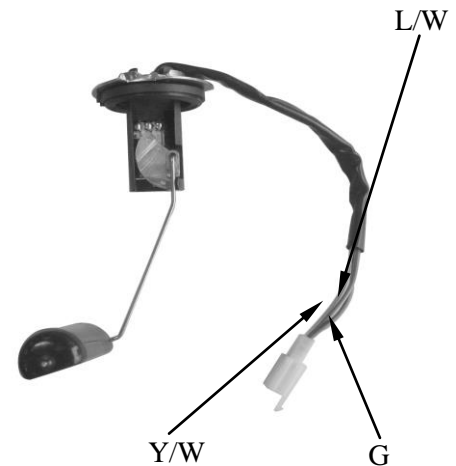

FUEL GAUGE INSPECTION

Connect the fuel unit wire connector and turn the ignition switch "ON".

* Before performing the following test, operate the turn signals to determine that the battery circuit is normal.

Check the fuel gauge needle for correct indication by moving the fuel unit float up and down.

Float Position	Needle Position
Upper	"F" (Full)
Lower	"E" (Empty)

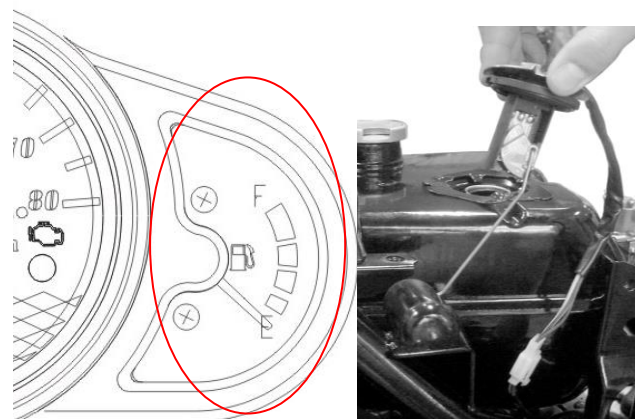

HANDLEBAR SWITCHES

INSPECTION

Remove the handlebar front cover. (⇒2-2)
 Disconnect the handlebar switch couplers and check for continuity between wire terminals.
 If there is any abnormality found, check each switch.

* Use the X1Ω range for test when using an electric tester.

STARTER SWITCH

Color	Yellow/Red	Green
FREE		
PUSH	○	○

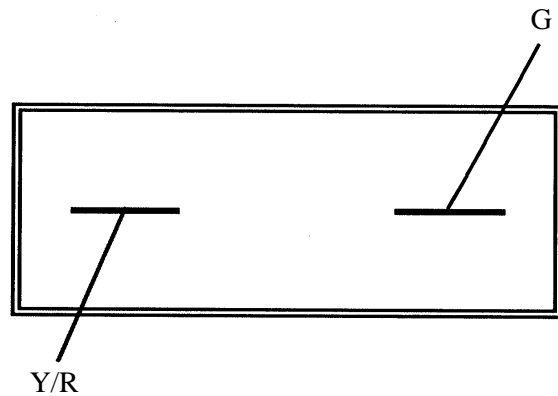

DIMMER SWITCH

Color	White	Blue/White	Blue
☰	○	○	
☷		○	○

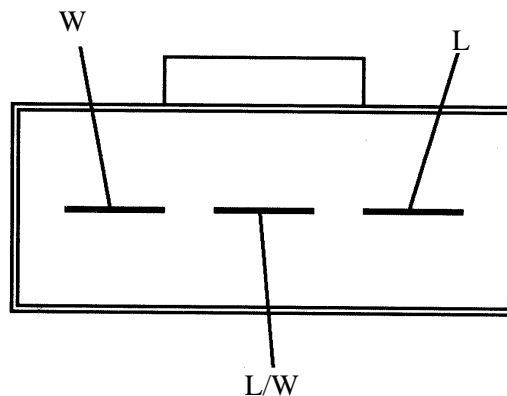

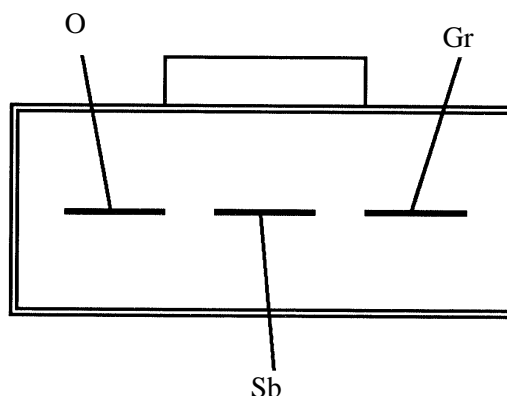

TURN SIGNAL SWITCH

Color	Gray	Light Blue	Orange
R	○	○	
N			
L	○		○



HORN SWITCH

Color	Light Green	Black
FREE		
PUSH		

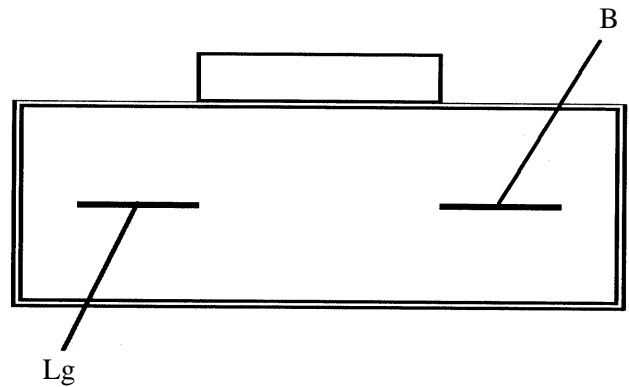







SWITCH REPLACEMENT

Remove the front covers. (⇒2-2)
 Remove the handlebar front cover. (⇒2-2)
 The installation sequence is the reverse of removal.

IGNITION SWITCH

INSPECTION

Remove the front covers. (⇒2-2)
 Disconnect the ignition switch wire coupler.
 Check for continuity between the wire terminals.

Color	Black	Red	Blue/ Yellow	Green
OFF				
ON				
LOCK				

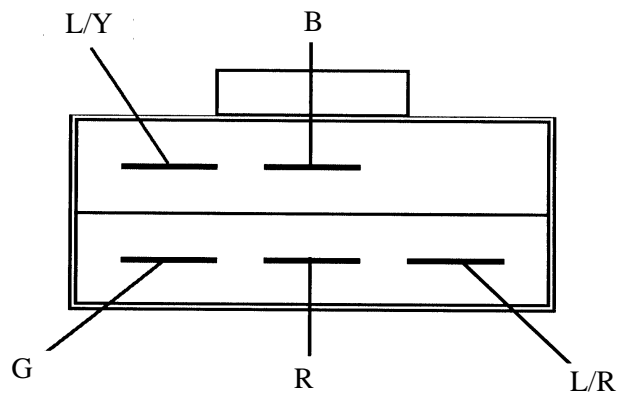

IGNITION SWITCH REPLACEMENT

Remove the front covers. (⇒2-2)
 Disconnect the ignition switch wire coupler.
 Remove the two mounting bolts to remove the ignition switch decorative ring and holder.
 Remove the two screws to remove the ignition switch from the ignition switch holder for replacement.
 The installation sequence is the reverse of removal.



Bolts

STOP SWITCH

INSPECTION

Remove the handlebar front cover. (⇒2-2)
 Disconnect the front stop switch wire coupler.
 Check for continuity between the wire terminals when the front brake lever is applied. The switch is normal if there is continuity.
 Disconnect the rear stop switch wire coupler.
 Check for continuity between the wire terminals when the rear brake lever is applied. The switch is normal if there is continuity.



Stop Switch Wire

HORN

INSPECTION

Remove the front covers. (⇒2-2)
 Disconnect the horn wire coupler.
 The horn is normal if it sounds when a 12V battery is connected across the horn wire terminals.

REPLACEMENT

Disconnect the horn wire coupler.
 Remove the two bolts attaching the horn.
 Remove the horn.
 The installation sequence is the reverse of removal.



INSTRUMENTS

Remove the handlebar front cover. (⇒2-2)
 Remove the handlebar rear cover. (⇒2-2)
 Disconnect the handlebar switch couplers.
 Remove the three screws to remove the instruments.
 Install a new horn in the reverse order of removal.

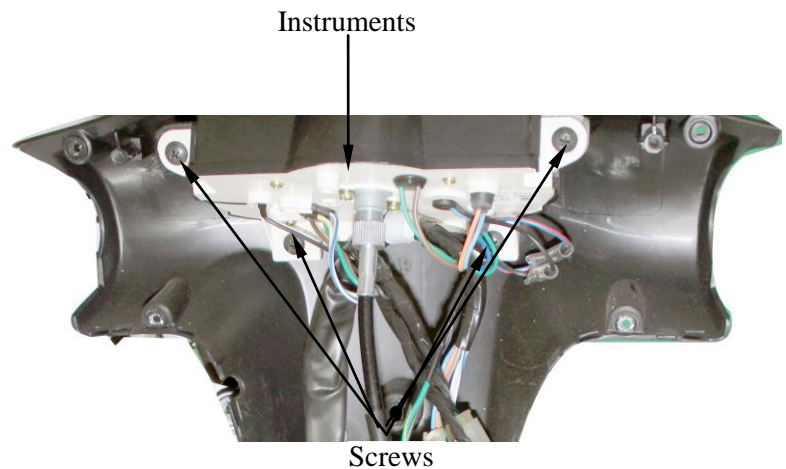

17. LIGHTS/INSTRUMENTS/SWITCHES

HEADLIGHT

REMOVAL

Remove the screw on the front of the front cover.

Remove the six screws on the back of the front cover.

Remove the front cover.

The installation sequence is the reverse of removal.

*

- Align the tab on the headlight with the groove on the handlebar cover.
- After installation, adjust the headlight beam. (⇒3-9)

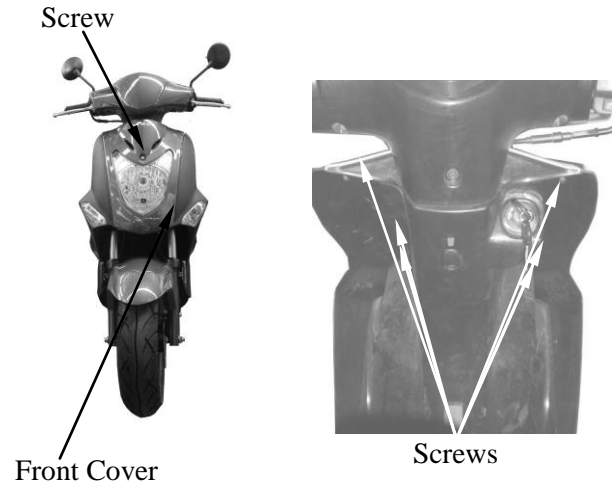

BULB REPLACEMENT

Remove the headlight bulb Coupler. (⇒2-2)

Remove the headlight replace with new bulbs.

The installation sequence is the reverse of removal.

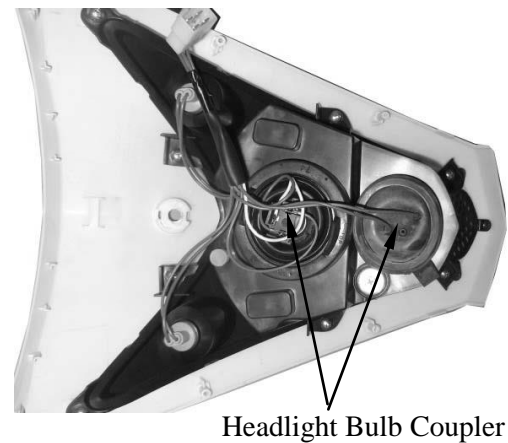

TAILLIGHT/STOPLIGHT/REAR TURN SIGNAL LIGHT/LICENSE LIGHT

Remove the rear protector molding and remove the two nuts attaching the rear light shell.

The installation sequence is the reverse of removal.

