

**By KWANG YANG Motor Co., Ltd.  
1st Edition, Jun. 2012  
All rights reserved. Any reproduction or  
unauthorized use without the written  
permission of KWANG YANG Motor Co., Ltd.  
is expressly prohibited.  
T300-LKD8-A1**

---

## PREFACE

This Service Manual describes the technical features and servicing procedures for the KYMCO **G-DINK 50**.

Section 1 contains the precautions for all operations stated in this manual. Read them carefully before any operation is started.

Section 2 is the removal/installation procedures for the frame covers which are subject to removal/installation frequency during maintenance and servicing operations.

Section 3 describes the inspection/adjustment procedures, safety rules and service information for each part, starting from periodic maintenance.

Sections 5 to 11 give instructions for disassembly, assembly and adjustment of engine parts. Section 12 to 13 is the removal/installation of chassis. Section 14 to 17 states the testing and measuring methods of electrical equipment.

Most sections start with an assembly or system illustration and troubleshooting for the section. The subsequent pages give detailed procedures for the section.

**The information and contents included in this manual may be different from the motorcycle in case specifications are changed.**

**KWANG YANG MOTOR CO., LTD.  
QUALITY TECHNOLOGY DEPT.  
EDUCATION SECTION**

## TABLE OF CONTENTS

ENGINE	GENERAL INFORMATION	1
	EXHAUST MUFFLER/FRAME COVERS	2
	INSPECTION/ADJUSTMENT	3
	LUBRICATION SYSTEM	4
	ENGINE REMOVAL/INSTALLATION	5
	CYLINDER HEAD/CYLINDER/PISTON	6
	A.C. GENERATOR/STARTER CLUTCH	7
	KICK STARTER/DRIVE PULLEY/CLUTCH/DRIVEN PULLEY	8
	FINAL REDUCTION	9
	CRANKCASE/CRANKSHAFT	10
	CARBURETOR	11
CHASSIS	STEERING HANDLEBAR/FRONT WHEEL/FRONT BRAKE/FRONT SHOCK ABSORBER/FRONT FORK	12
	REAR BRAKE/REAR FORK/REAR WHEEL/REAR SHOCK ABSORBER	13
ELECTRICAL EQUIPMENT	BATTERY/CHARGING SYSTEM	14
	IGNITION SYSTEM	15
	STARTING SYSTEM	16
	LIGHTS/METERS/SWITCHES	17

# 1. GENERAL INFORMATION

---



---

---

---

---

---

---

---

---

## GENERAL INFORMATION

---

SERIAL NUMBER .....	1-1
SPECIFICATION .....	1-2
SERVICE PRECAUTIONS .....	1-3
TORQUE VALUES .....	1-8
SPECIAL TOOLS .....	1-10
LUBRICATION POINTS .....	1-11
CABLE & HARNESS ROUTING .....	1-12
TROUBLESHOOTING .....	1-23

# 1. GENERAL INFORMATION

## Identification Numbers Record

### Identification Numbers Record



①



②



③

#### 1. VEHICLE IDENTIFICATION NUMBER (VIN)

#### 2. ENGINE SERIAL NUMBER (ESN)

#### 3. FRAME SERIAL NUMBER (VIN)

Record the Vehicle Identification Number ①, Engine Serial Number ② and Frame Serial Number ③ in the boxes above for future reference (to assist you in ordering parts from your authorized KYMCO dealer or for reference in case the vehicle is stolen).

# 1. GENERAL INFORMATION

## SPECIFICATIONS

Oil tank capacity	1.1 liter	
<b>Fuel system</b>		
Fuel capacity	9.5 liters	
Carburetor type	VE	
Throttle Body	Butterfly type	
Venturi diameter (mm)	17	
<b>Electrical system</b>		
Ignition type	CDI	
Spark plug	NGK CR7HSA	
Spark plug gap	0.6~0.7mm	
Battery Capacity	12V4AH	
<b>Transmission system</b>		
Clutch type	Dry multi-disc	
Transmission type	CVT	
Operation type	Auto centrifugal	
Reduction gear type	Two-stage reduction	
Reduction ratio	1 <sup>st</sup>	0.75-2.47
	2 <sup>nd</sup>	13.61
<b>Moving device</b>		
Tire type	Tubeless	
Tire spec.	Front wheel	120/70-13
	Rear wheel	130/70-12
Tire pressure (kg/cm <sup>2</sup> )	Front wheel	2.0
	Rear wheel	2.25
Wheel material	Aluminium	
Turning angle	Left	45°
	Right	45°
Brake type	Front	Disk brake
	Rear	Drum
<b>Damping Device</b>		
Suspension type	Front	Telescope
	Rear	Swing arm
Shock absorber stroke	Front	110 mm
	Rear	100 mm

Name	G-DINK 50	
Model No.	SF10RA	
Overall length	2110 mm	
Overall width	765 mm	
Overall height	1270 mm	
Wheel base	1470 mm	
Engine type	2 stroke O.H.C.	
Displacement	49.5 cc	
Fuel Used	92# nonleaded gasoline above	
Curb weight (kg)	Front wheel	54
	Rear wheel	74
	Total	128
Max. weight capacity (kg)	Front wheel	87
	Rear wheel	115
	Total	205
Ground clearance (mm)	135	
Braking distance (m)	7.9m / 40 km/hr	
Min. turning radius (mm)	2250	
<b>Engine part</b>		
Starting system	Starting motor & Kick start	
Cylinder arrangement	Single cylinder	
Combustion chamber type	Semi-sphere	
Bore x stroke (mm)	φ 39 *41.4	
Compression ratio	11:1	
Compression pressure (kg/cm <sup>2</sup> )	18	
Max. output (kw/rpm)	3.5 /7500	
Max. torque (N-m/rpm)	3.5 / 7000	
Idle speed (rpm)	1700±100 rpm	
Cooling Type	Forced Air	
Lubrication type	Separate type	

# 1. GENERAL INFORMATION

## SERVICE PRECAUTIONS

- Make sure to install new gaskets, O-rings, circlips, cotter pins, etc. when reassembling.

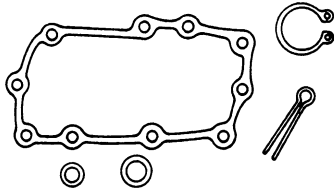

- When tightening bolts or nuts, begin with larger-diameter to smaller ones at several times, and tighten to the specified torque diagonally.

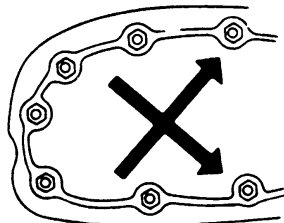

- Use genuine parts and lubricants.

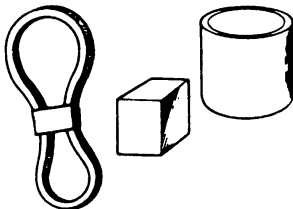

- When servicing the motorcycle, be sure to use special tools for removal and installation.



- After disassembly, clean removed parts. Lubricate sliding surfaces with engine oil before reassembly.

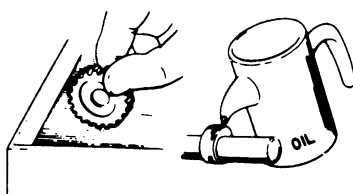

- Apply or add designated greases and lubricants to the specified lubrication points.

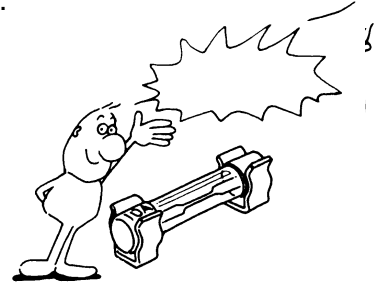

- When two persons work together, pay attention to the mutual working safety.

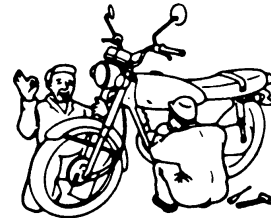

- Disconnect the battery negative (-) terminal before operation.
- When using a spanner or other tools, make sure not to damage the motorcycle surface.

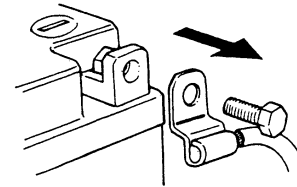

- After operation, check all connecting points, fasteners, and lines for proper connection and installation.
- When connecting the battery, the positive (+) terminal must be connected first.
- After connection, apply grease to the battery terminals.
- Terminal caps shall be installed securely.

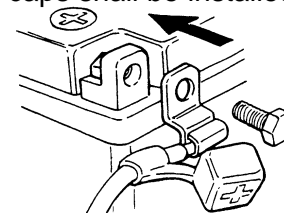

- If the fuse is burned out, find the cause and repair it. Replace it with a new one according to the specified capacity.

# 1. GENERAL INFORMATION

- After operation, terminal caps shall be installed securely.

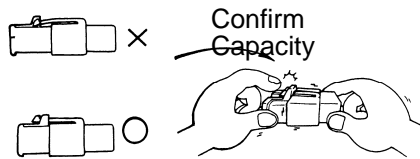

- When taking out the connector, the lock on the connector shall be released before operation.

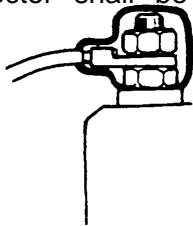

- Hold the connector body when connecting or disconnecting it.
- Do not pull the connector wire.

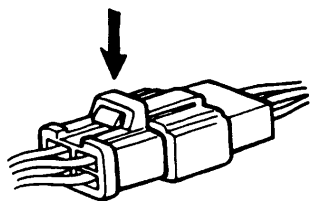

- Check if any connector terminal is bending, protruding or loose.



- The connector shall be inserted completely.
- If the double connector has a lock, lock it at the correct position.
- Check if there is any loose wire.

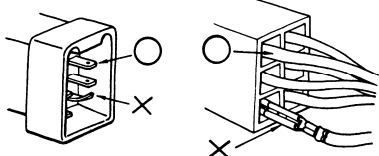

- Before connecting a terminal, check for damaged terminal cover or loose negative terminal.

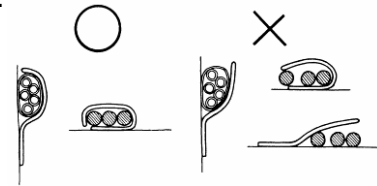

- Check the double connector cover for proper coverage and installation.

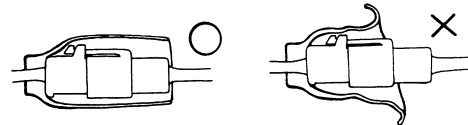

- Insert the terminal completely.
- Check the terminal cover for proper coverage.
- Do not make the terminal cover opening face up.

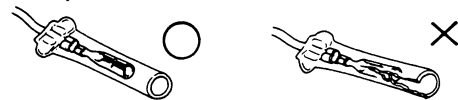

- Secure wire harnesses to the frame with their respective wire bands at the designated locations. Tighten the bands so that only the insulated surfaces contact the wire harnesses.

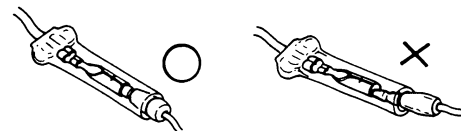

- After clamping, check each wire to make sure it is secure.

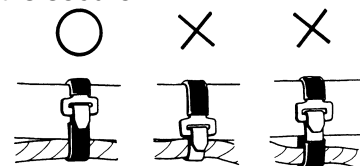

# 1. GENERAL INFORMATION

- Do not squeeze wires against the weld or its clamp.

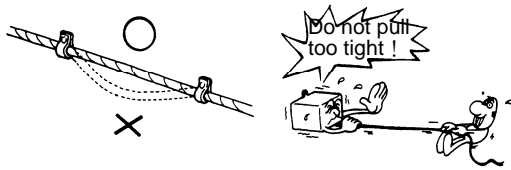

- After clamping, check each harness to make sure that it is not interfering with any moving or sliding parts.



- When fixing the wire harnesses, do not make it contact the parts that will generate high heat.

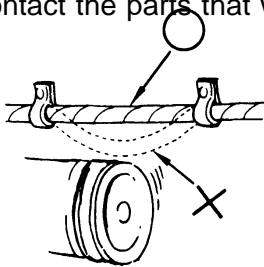

- Route wire harnesses to avoid sharp edges or corners. Avoid the projected ends of bolts and screws.
- Route wire harnesses passing through the side of bolts and screws. Avoid the projected ends of bolts and screws.

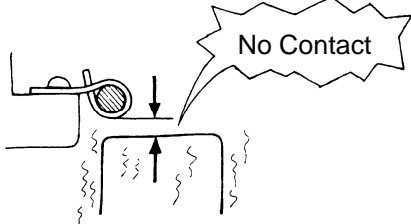

- Route harnesses so they are neither pulled tight nor have excessive slack.

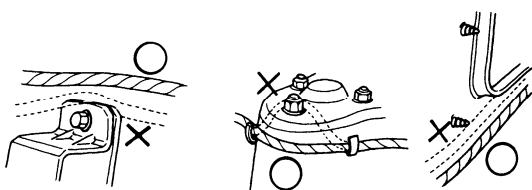

- Protect wires and harnesses with electrical tape or tube if they contact a sharp edge or corner.

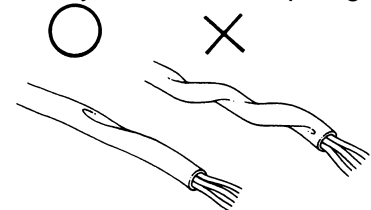

- When rubber protector cover is used to protect the wire harnesses, it shall be installed securely.

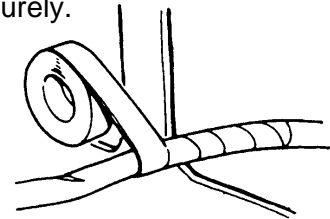

- Do not break the sheath of wire.
- If a wire or harness is with a broken sheath, repair by wrapping it with protective tape or replace it.

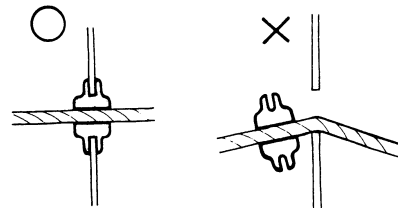

- When installing other parts, do not press or squeeze the wires.

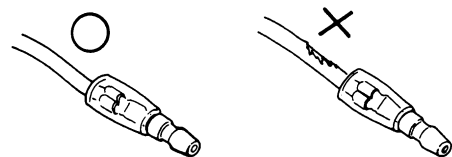

- After routing, check that the wire harnesses are not twisted or kinked.

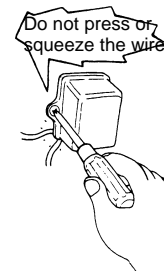

# 1. GENERAL INFORMATION

---

- Wire harnesses routed along with handlebar should not be pulled tight, have excessive slack or interfere with adjacent or surrounding parts in all steering positions.

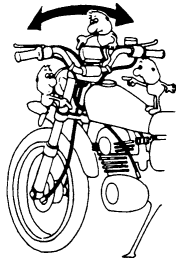

- When a testing device is used, make sure to understand the operating methods thoroughly and operate according to the operating instructions.

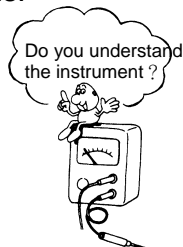

- Be careful not to drop any parts.

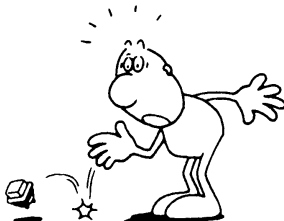

- When rust is found on a terminal, remove the rust with sand paper or equivalent before connecting.



# 1. GENERAL INFORMATION

## ■ Symbols:

The following symbols represent the servicing methods and cautions included in this service manual.



: Apply engine oil to the specified points. (Use designated engine oil for lubrication.)



: Apply grease for lubrication.



: Transmission Gear Oil (90#)



: Use special tool.



: Caution



: Warning

# 1. GENERAL INFORMATION

## TORQUE VALUES

### STANDARD TORQUE VALUES

Item	Torque (kgf-m)	Item	Torque (kgf-m)
5mm bolt, nut	0.45~0.6	5mm screw	0.45~0.6
6mm bolt, nut	0.8~1.2	6mm screw, SH bolt	0.7~1.1
8mm bolt, nut	1.8~2.5	6mm flange bolt, nut	1.0~1.4
10mm bolt, nut	3.0~4.0	8mm flange bolt, nut	2.4~3.0
12mm bolt, nut	5.0~6.0	10mm flange bolt, nut	3.0~4.5

### ENGINE

Item	Thread dia. (mm)	Torque (kg-m)	Remarks
Cylinder head bolt	BF7x115	1.5~1.7	(cold)
Clutch drive plate nut	10	3.5~4.0	
Clutch outer nut	NH10	3.5~4.5	
Drive face nut	NH12	5.0~6.0	
Oil check bolt	10	1.0~1.5	
Engine mounting bolt	BF10x95	4.5~5.5	
Engine hanger bracket bolt	BF10x50	3.5~4.5	
Exhaust muffler joint lock nut	NC6mm	1.0~1.4	
Exhaust muffler lock bolt	BF8x35	3.0~3.6	
Spark plug		1.1~1.7	(cold)

# 1. GENERAL INFORMATION

## TORQUE VALUES FRAME

No.	ITEM	THREAD SIZE AND TYPE	TORQUE		PR値 Kgf-m	REMARK	THREAD DWG NO.
			Kgf-m	N-m			
1	STEERING						
	HANDLE POST	M10x1.25	6.0~7.0	60~70	6.5	U NUT	90106-GEN5-9000
	BRIDGE BOLT	M8x1.25	2.4~3.0	24~30	2.7	—	95801-08040-08
	STEM LOCK	BC1	6.0~6.5	60~65	6.3	—	50306-1F96-0010
	RACE NUT(HEAD)	BC1	1.8~2.2	18~22	2.0	—	53220-LBA2-E000
2	WHEEL						
	FR. AXLE	M14x1.5	1.5~2.5	15~25	2.0	—	44301-LLJ3-E000
	RR. AXLE NUT	M16x1.5	11~13	110~130	12	U NUT	90305-KFW6-9120-MI
3	SUSPENSION						
	FR FORK BOLT	M8x1.25	2.0~2.6	20~26	2.3	—	96600-08025-06
	RR. CUSH. UP	M10x1.25	3.5~4.5	35~45	4.0	U NUT	90304-GHE8-0040
	RR. CUSH. LWR	M8x1.25	2.4~3.0	24~30	2.7	—	95801-08042-06
4	BRAKE						
	FR CALIPER R	M10x1.25	3.0~4.0	30~40	3.5	—	90122-LEA7-E000
	BRK OIL BOLT	M10x1.25	3.0~4.0	30~40	3.5	—	90145-MS9-6120-MI
	M/C HOLDER	M6x1.0	1.0~1.4	10~14	1.2	—	96001-06028-06
	M/C CAP SCREW	M4x0.7	0.12~0.2	1.2~2.0	0.16	—	96000-04012-1A
	C/P BLEEDER	M8x1.25	0.4~0.7	4.0~7.0	0.55	—	43352-5H68-0040
	DISK BOLT	M8x1.25	3.2~3.8	32~38	3.5	—	90105-KCR3-0010
	C/P PIN BOLT	M12x1.25	3.4~4.6	34~46	4.0	—	45131-LDHI-E000
	REAR BRAKE ARM BOLT	M6x1.0	1.0~1.4	10~14	1.2	—	95701-06032-08
	HANDLE HOLDER	M6x1.0	1.0~1.4	10~14	1.2	—	96001-06028-06
5	ENGINE HANGER						
	FRAME SIDE	M14x1.5	6.0~7.0	60~70	6.5	U NUT	90305-LBD4-9000
	ENGINE SIDE (L)	M10x1.25	3.3~4.3	33~43	3.8	—	95701-10070-06
	ENGINE SIDE (R)	M10x1.25	3.3~4.3	33~43	3.8	—	95801-10100-06
6	MUFFLER						
	EXH. PIPE	M6x1.0	1.0~1.4	10~14	1.2	—	92700-06028-18
	MUFFLER BRKT.	M8x1.25	3.0~3.6	30~36	3.3	—	95801-KGB5-E000
	MUFFLER BRKT.	M8x1.25	3.0~3.6	30~36	3.3	—	95801-08075-06

# 1. GENERAL INFORMATION

## SPECIAL TOOLS

Tool No.		Description	Drawing	Specs
A120	E00001	FLYWHEEL PULLER		M24X1
A120	E00014	OIL SEAL & BEARING DRIVER		General size
A120	E00017	UNIVERSAL HOLDER		
A120	E00019	BUSHING ABSORBER REMOVER		O.D. 26
A120	E00025	39mm HEX NUT WRENCH		
A120	E00029	THREAD PROTECTOR		10mm, 12 mm
A120	E00030	CRANKSHAFT BEARING PULLER		
A120	E00032	BUSHING ENGINE HANGER REMOVER		O.D. 30
A120	E00034	CLUTCH SPRING COMPRESSOR		
A120	E00037	BEARING PULLER		General size

# 1. GENERAL INFORMATION

---

## LUBRICATION POINTS

### FRAME

The following is the lubrication points for the frame.

Use grease for parts not listed.

Apply engine oil or grease to cables and movable parts not specified. It will avoid abnormal noise and damage the durability of the motorcycle.

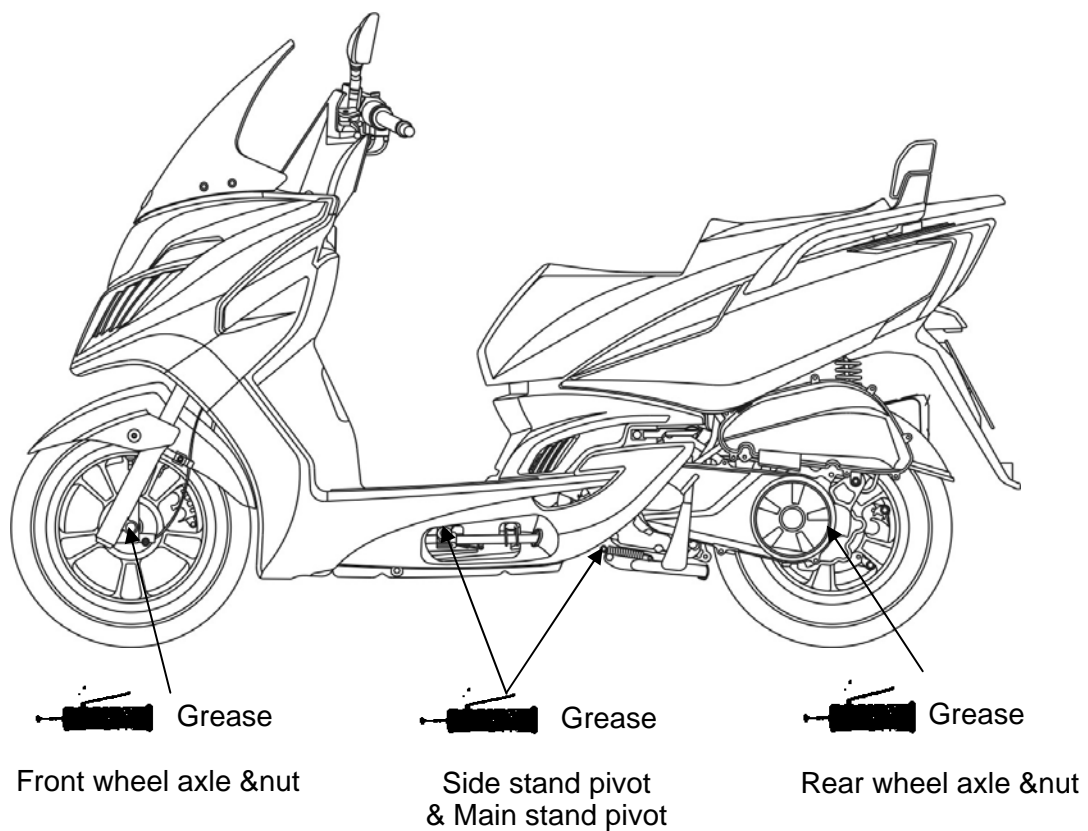

# 1. GENERAL INFORMATION

## CABLE & HARNESS ROUTING

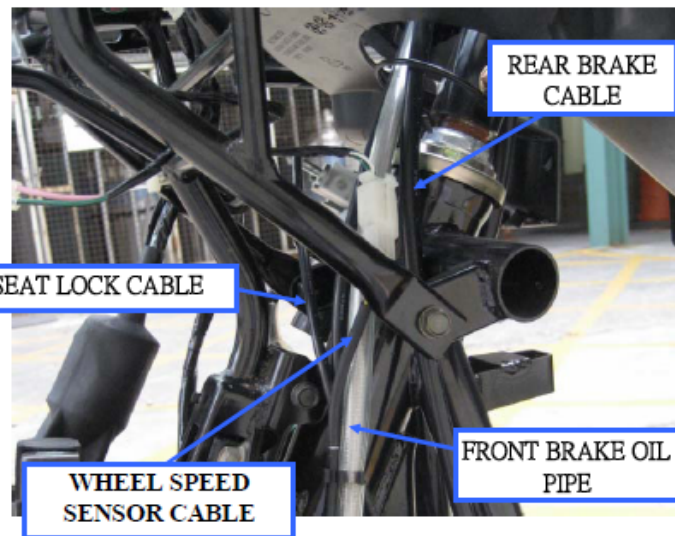
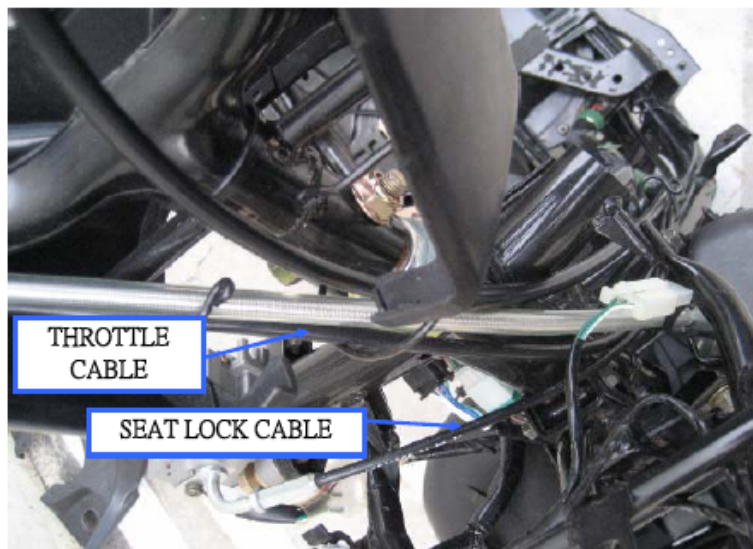
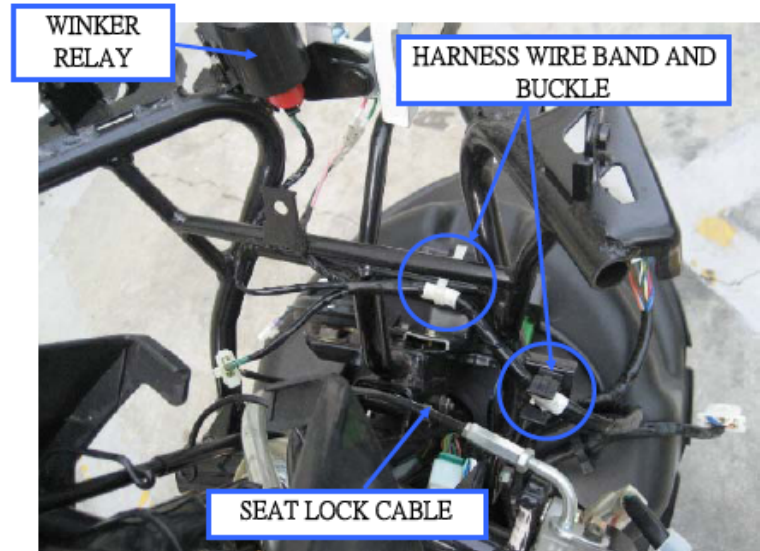
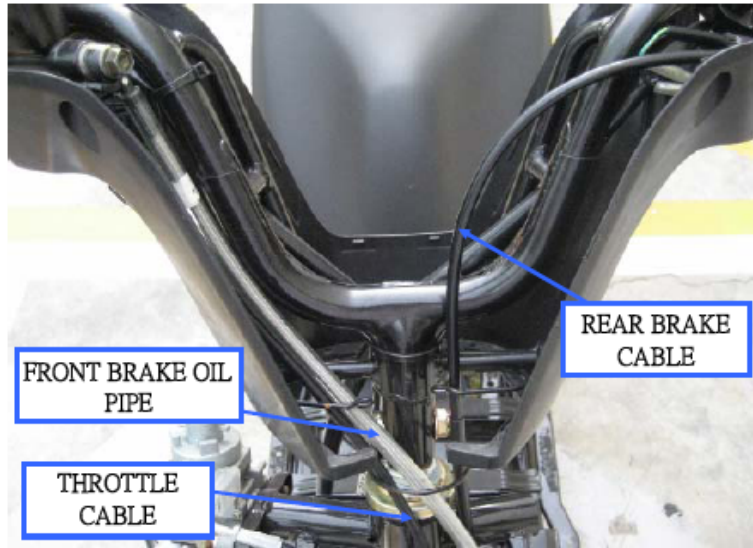

# 1. GENERAL INFORMATION

## CABLE & HARNESS ROUTING

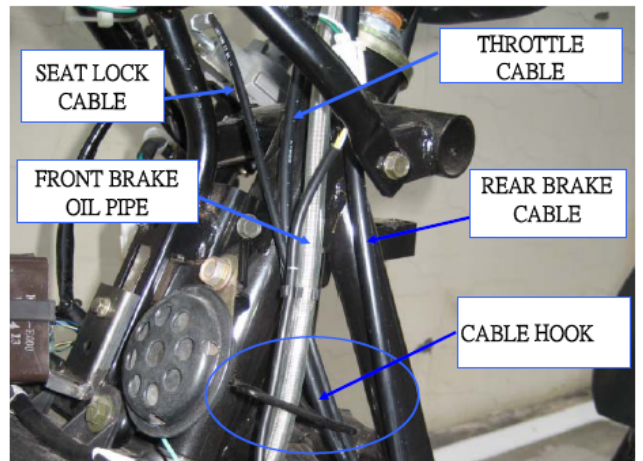
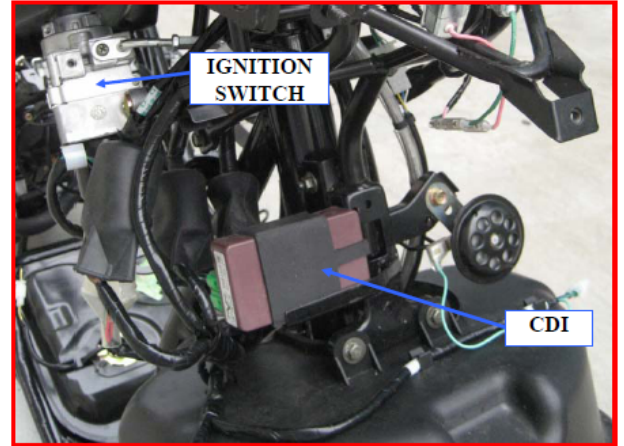
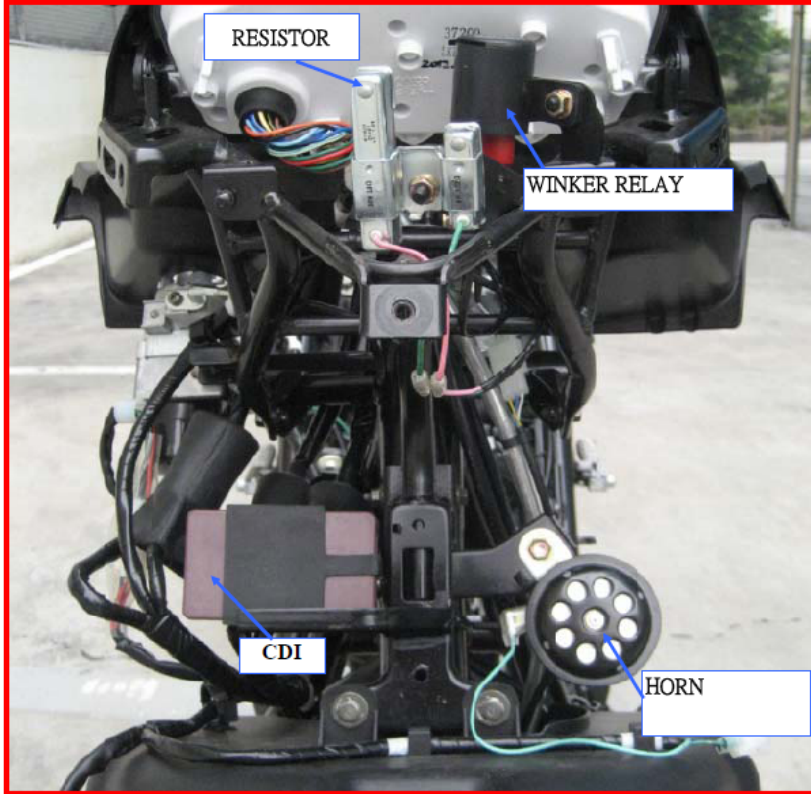

# 1. GENERAL INFORMATION

## CABLE & HARNESS ROUTING

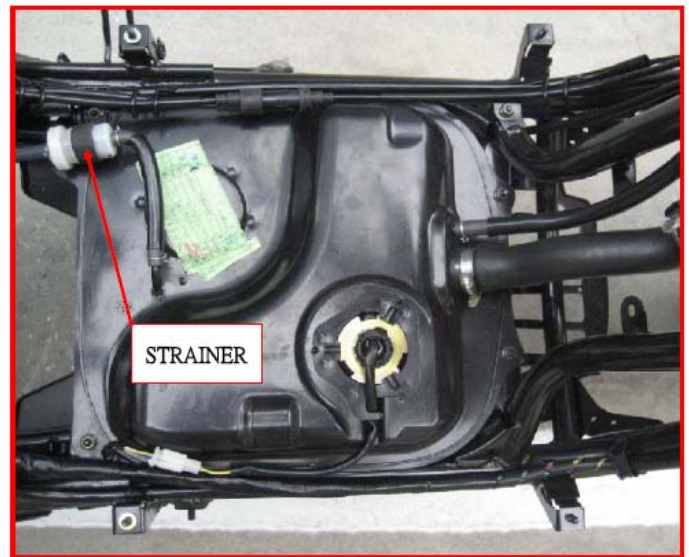

# 1. GENERAL INFORMATION

## CABLE & HARNESS ROUTING

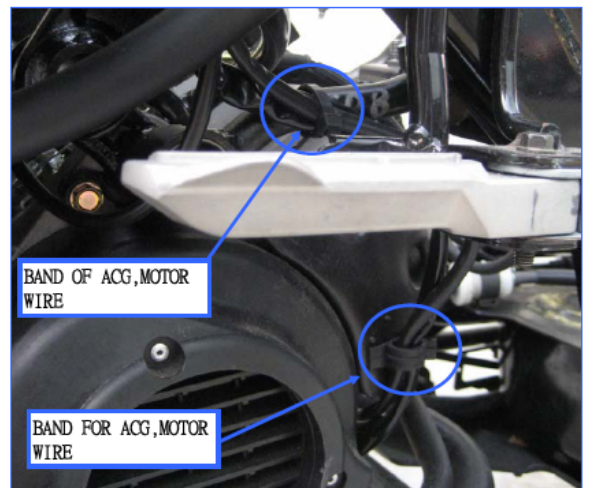
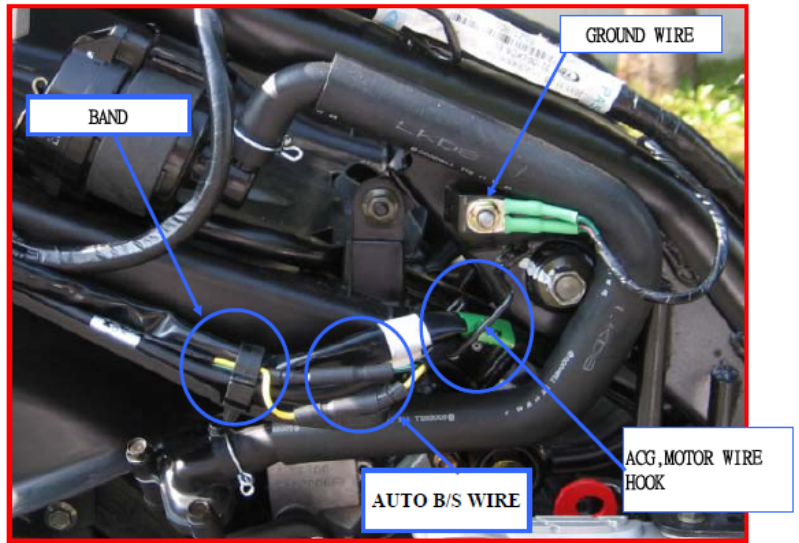
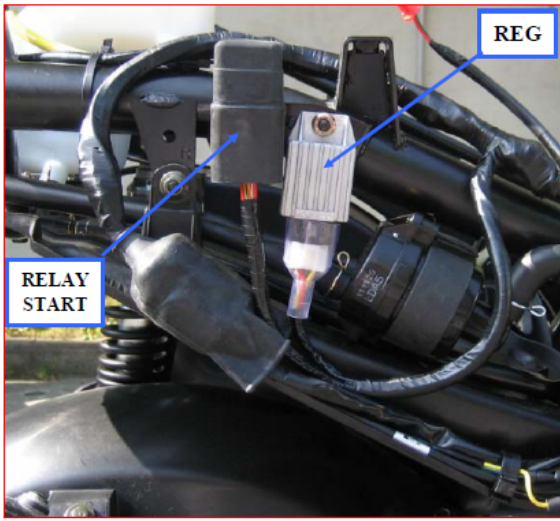

# 1. GENERAL INFORMATION

## CABLE & HARNESS ROUTING

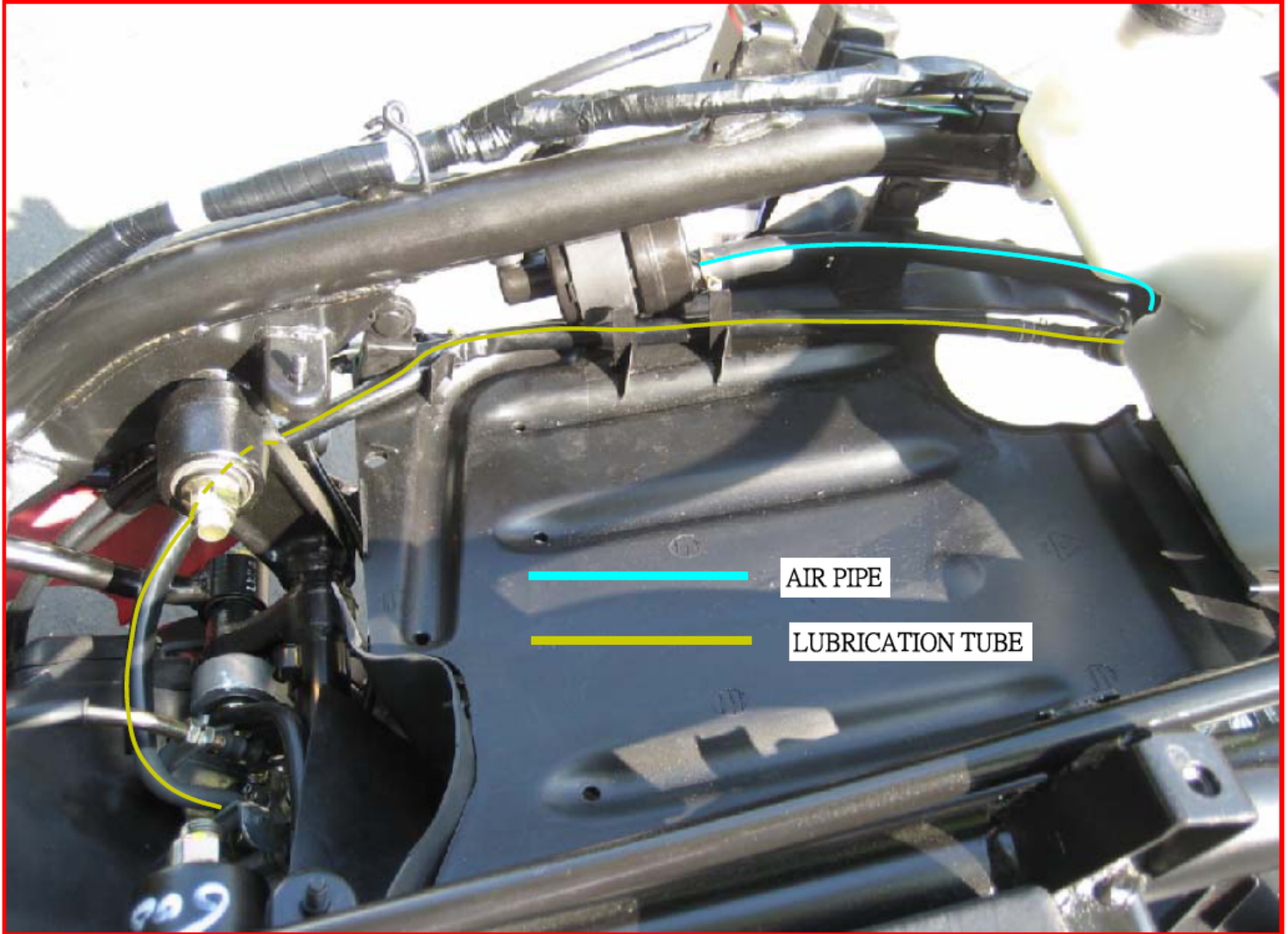

# 1. GENERAL INFORMATION

## CABLE & HARNESS ROUTING

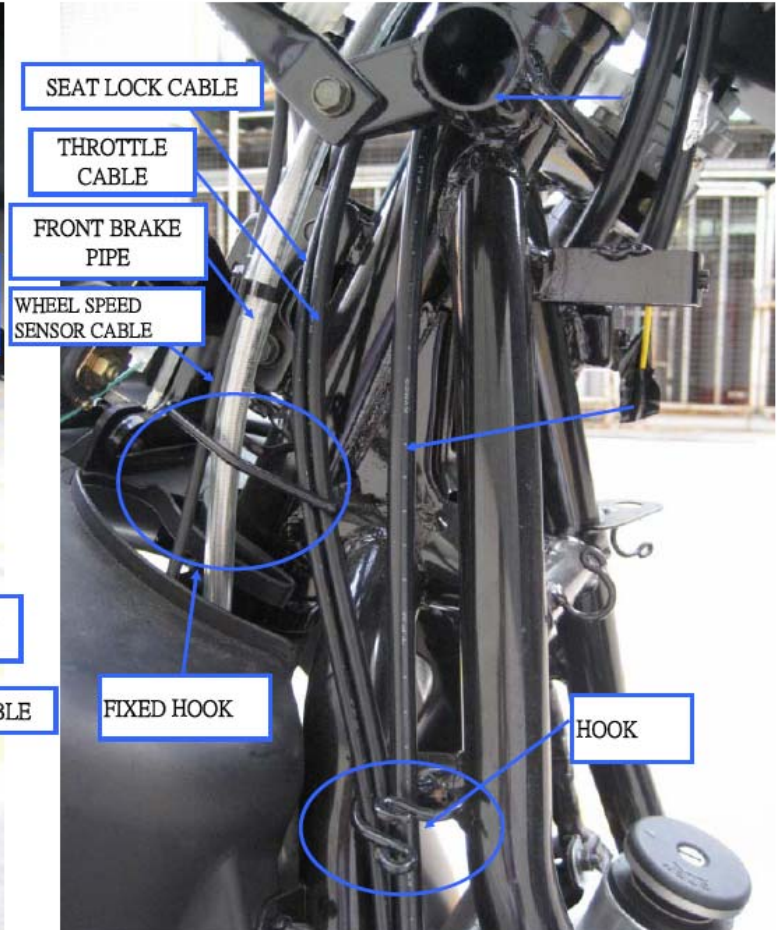
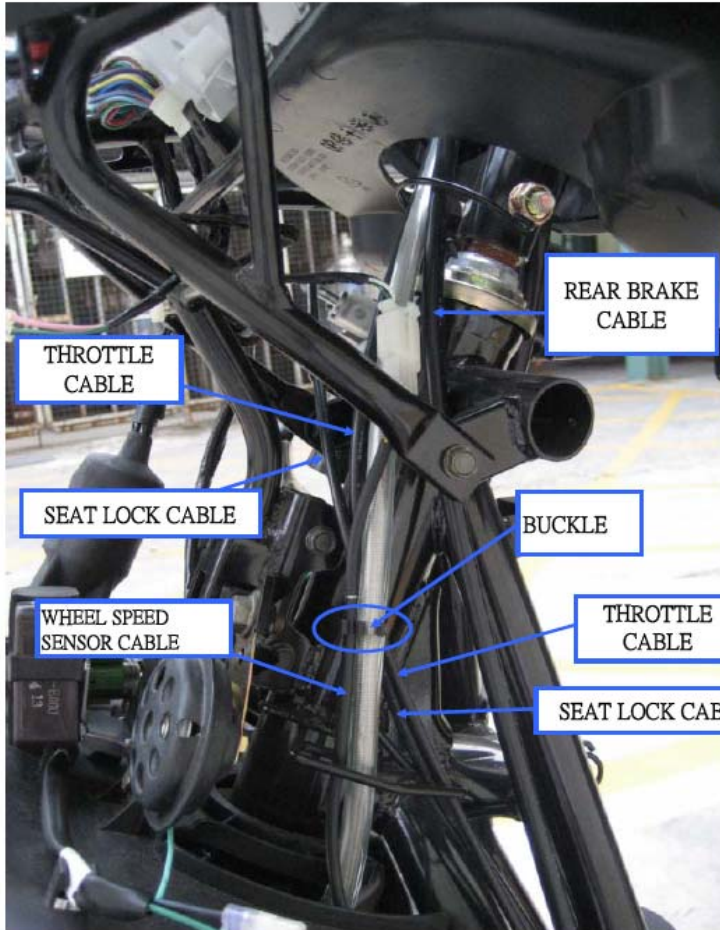

# 1. GENERAL INFORMATION

## CABLE & HARNESS ROUTING

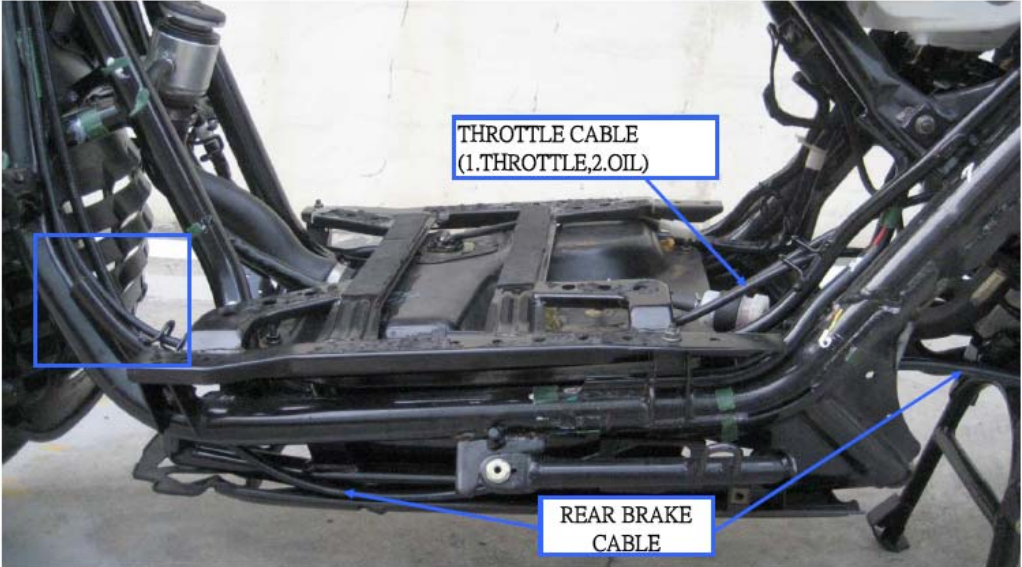
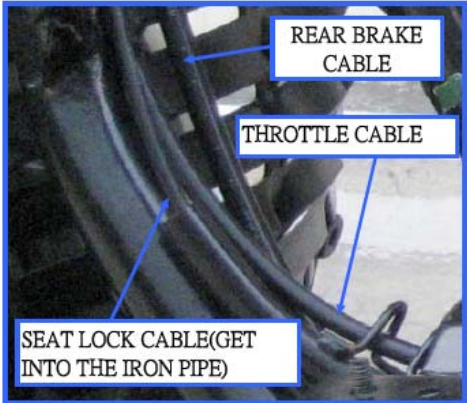
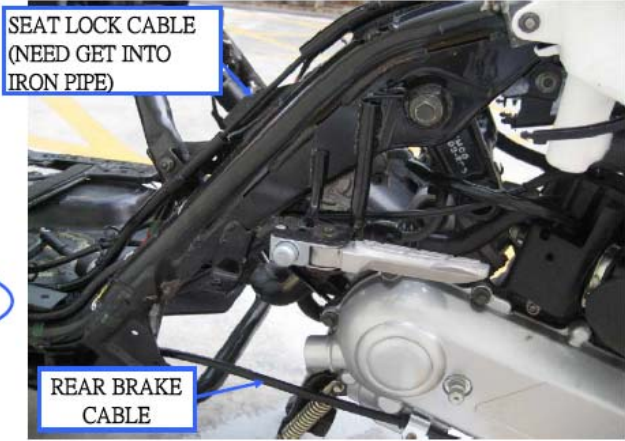
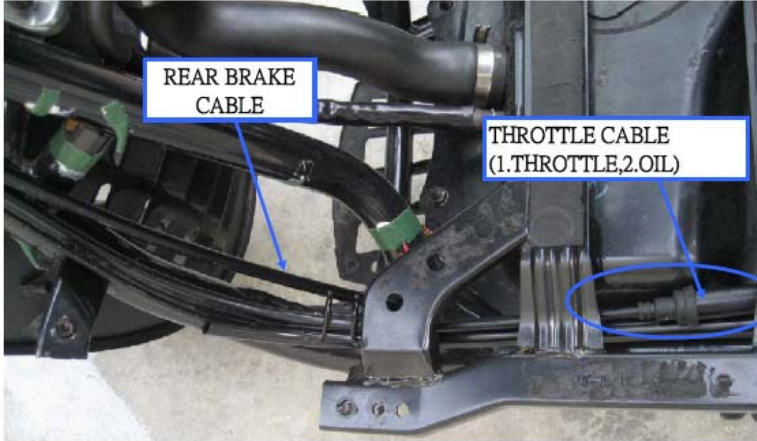

# 1. GENERAL INFORMATION

## CABLE & HARNESS ROUTING

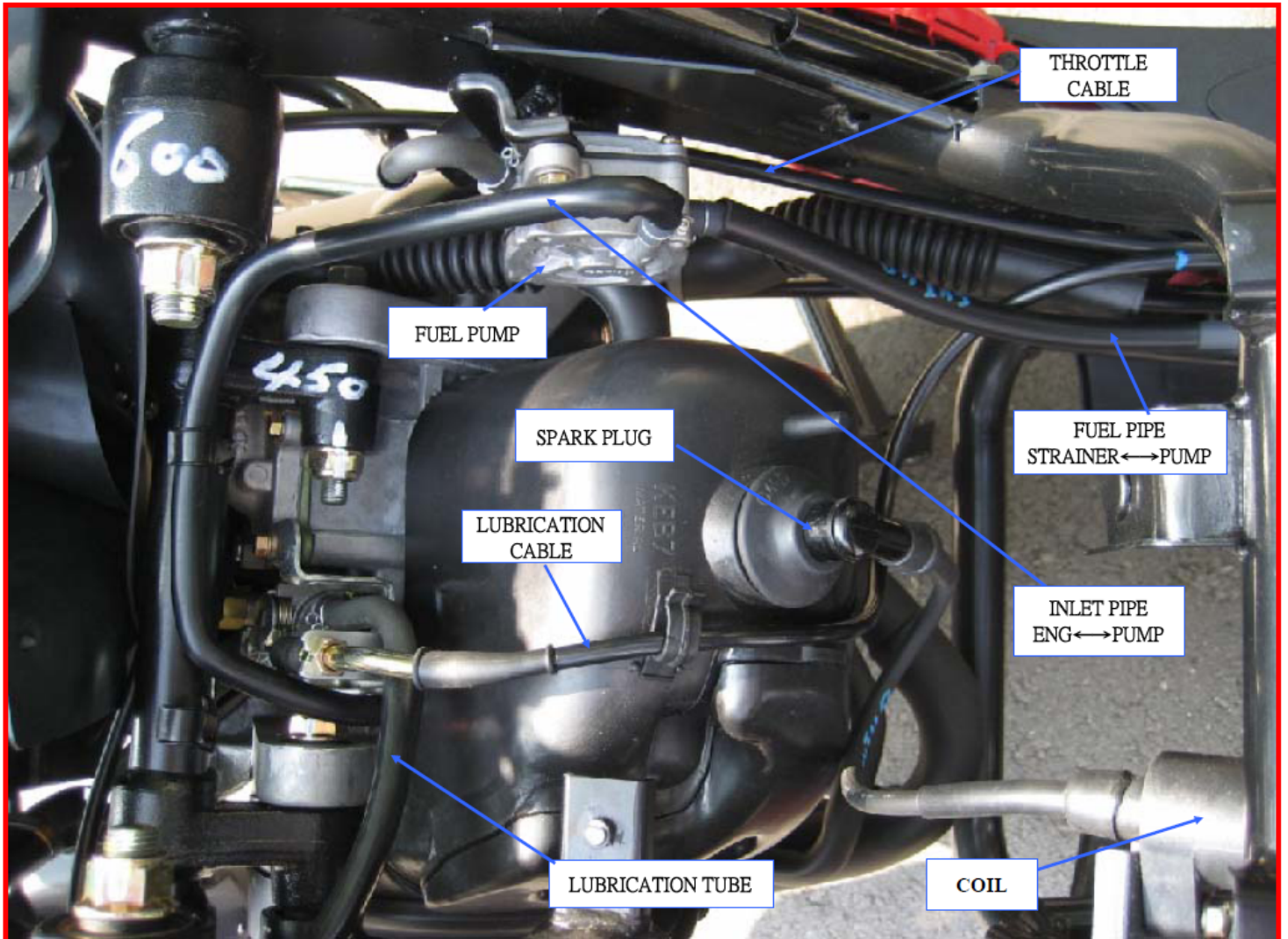

# 1. GENERAL INFORMATION

## CABLE & HARNESS ROUTING

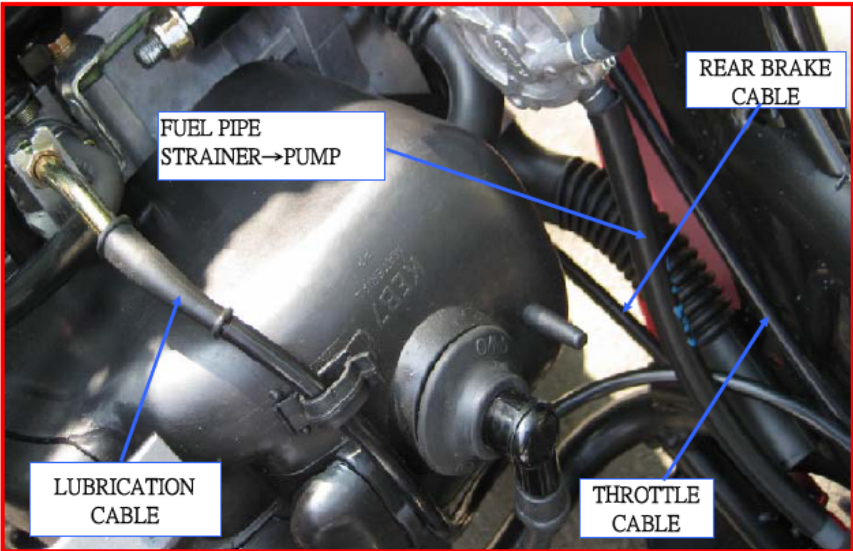
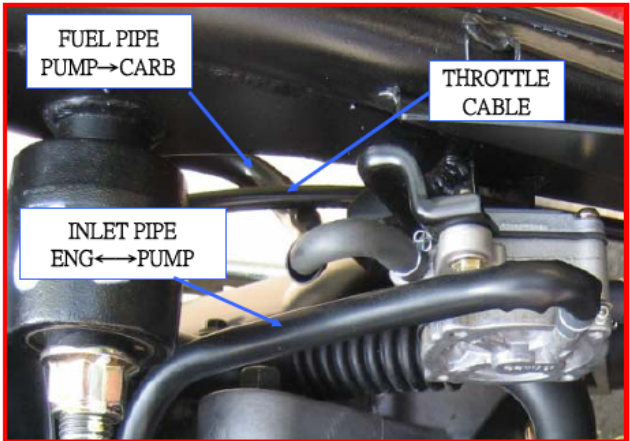
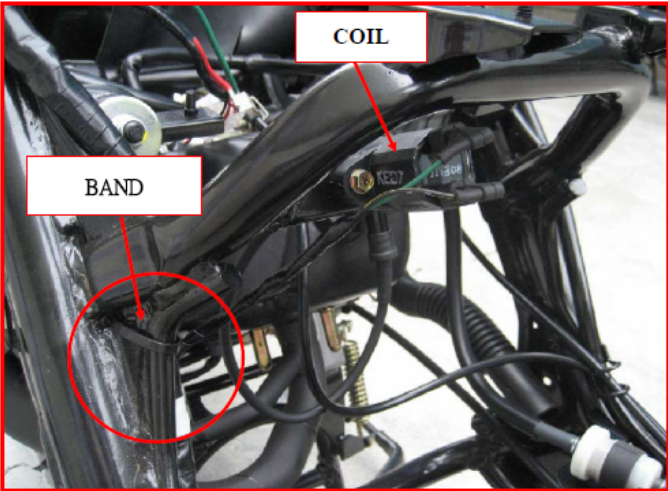
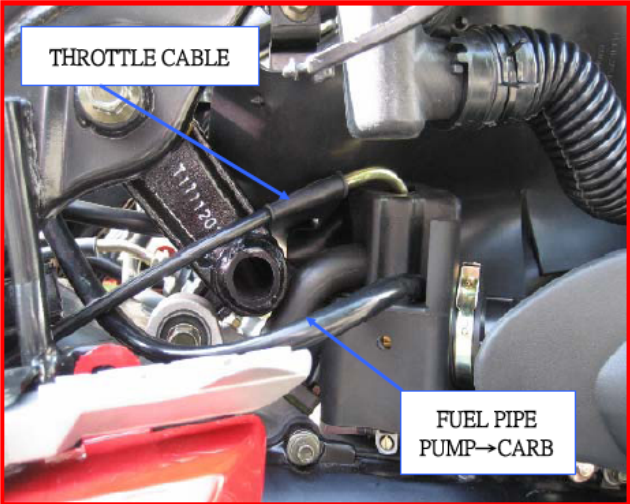

# 1. GENERAL INFORMATION

## CABLE & HARNESS ROUTING

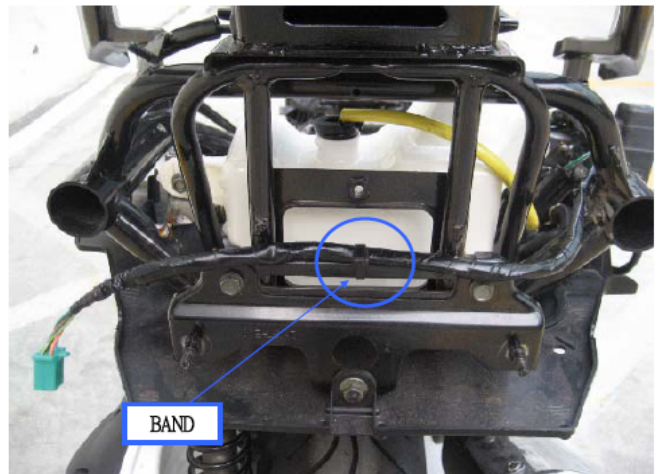
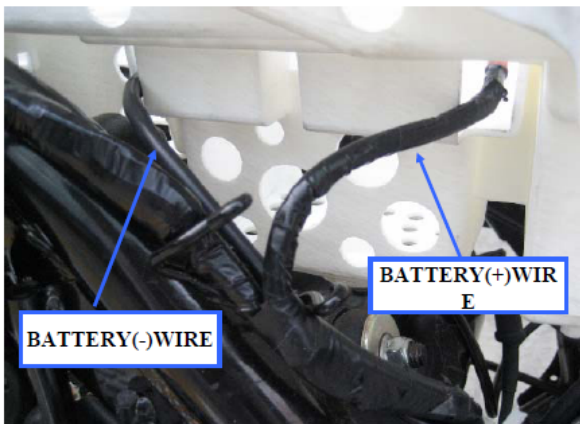
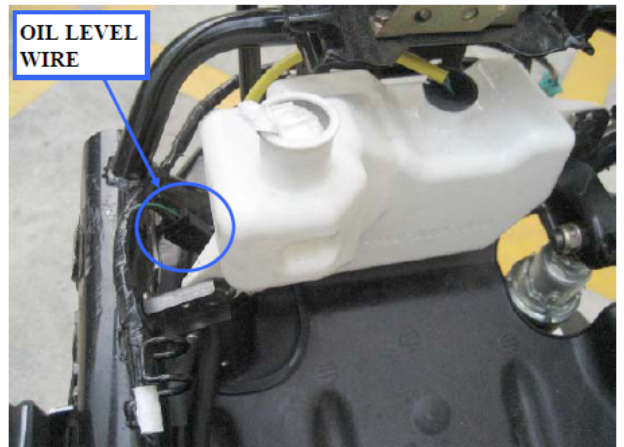
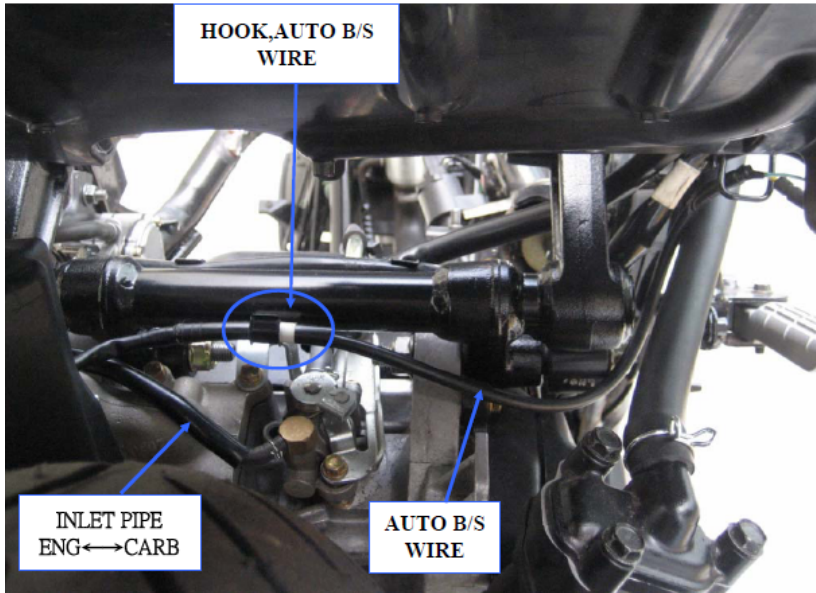

# 1. GENERAL INFORMATION

## TROUBLESHOOTING

### ENGINE WILL NOT START OR IS HARD TO START

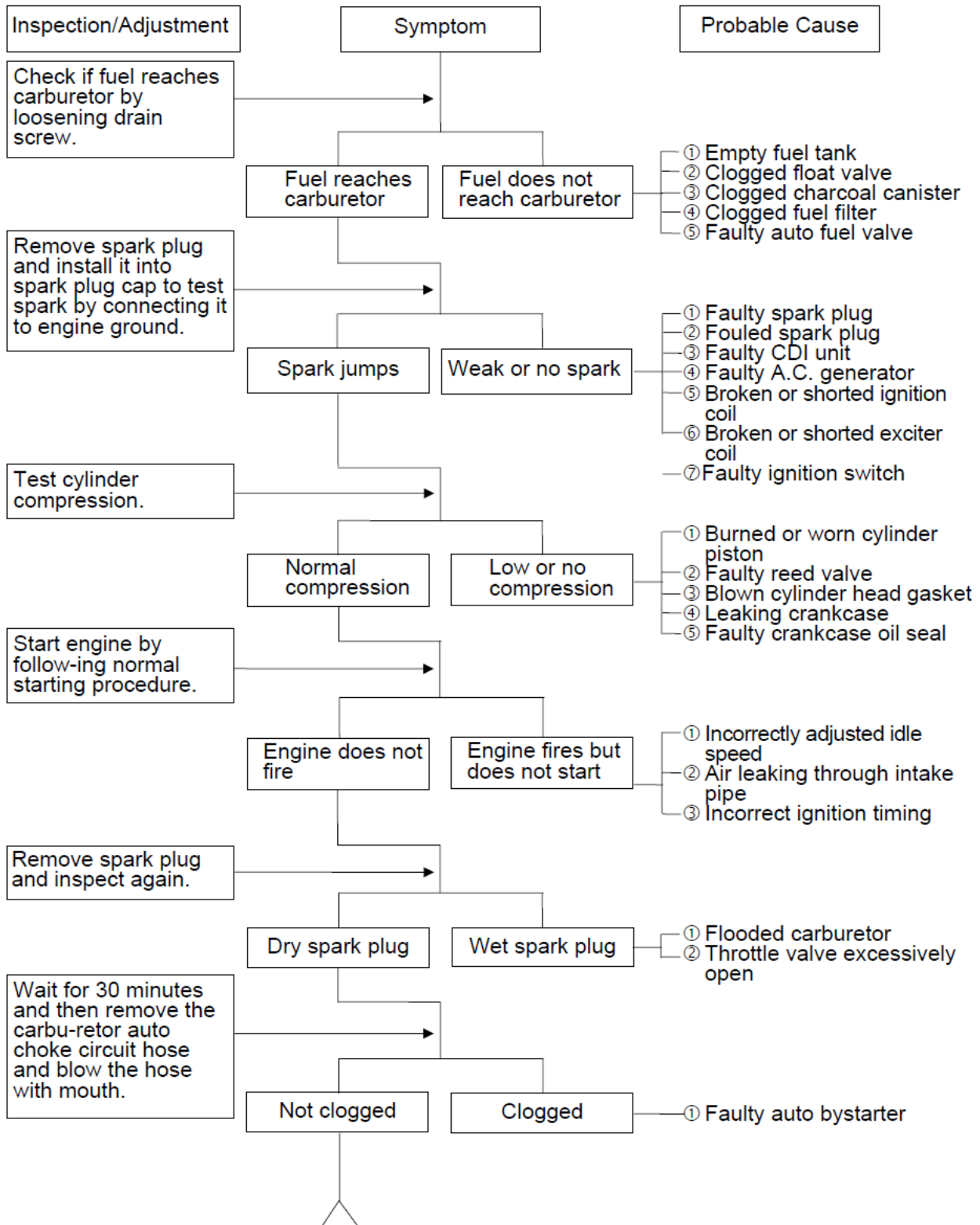

# 1. GENERAL INFORMATION

## ENGINE STOPS IMMEDIATELY AFTER IT STARTS

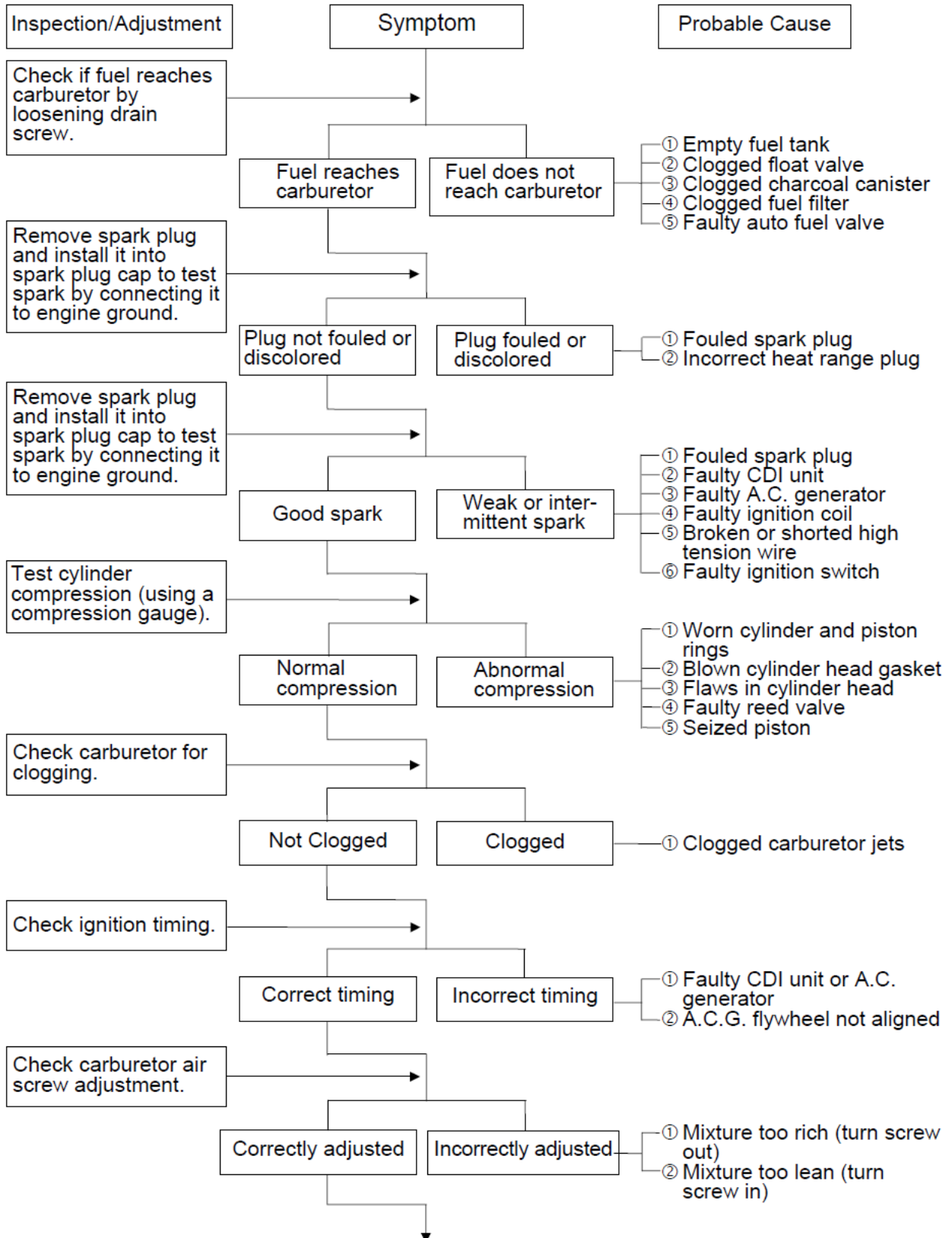

# 1. GENERAL INFORMATION

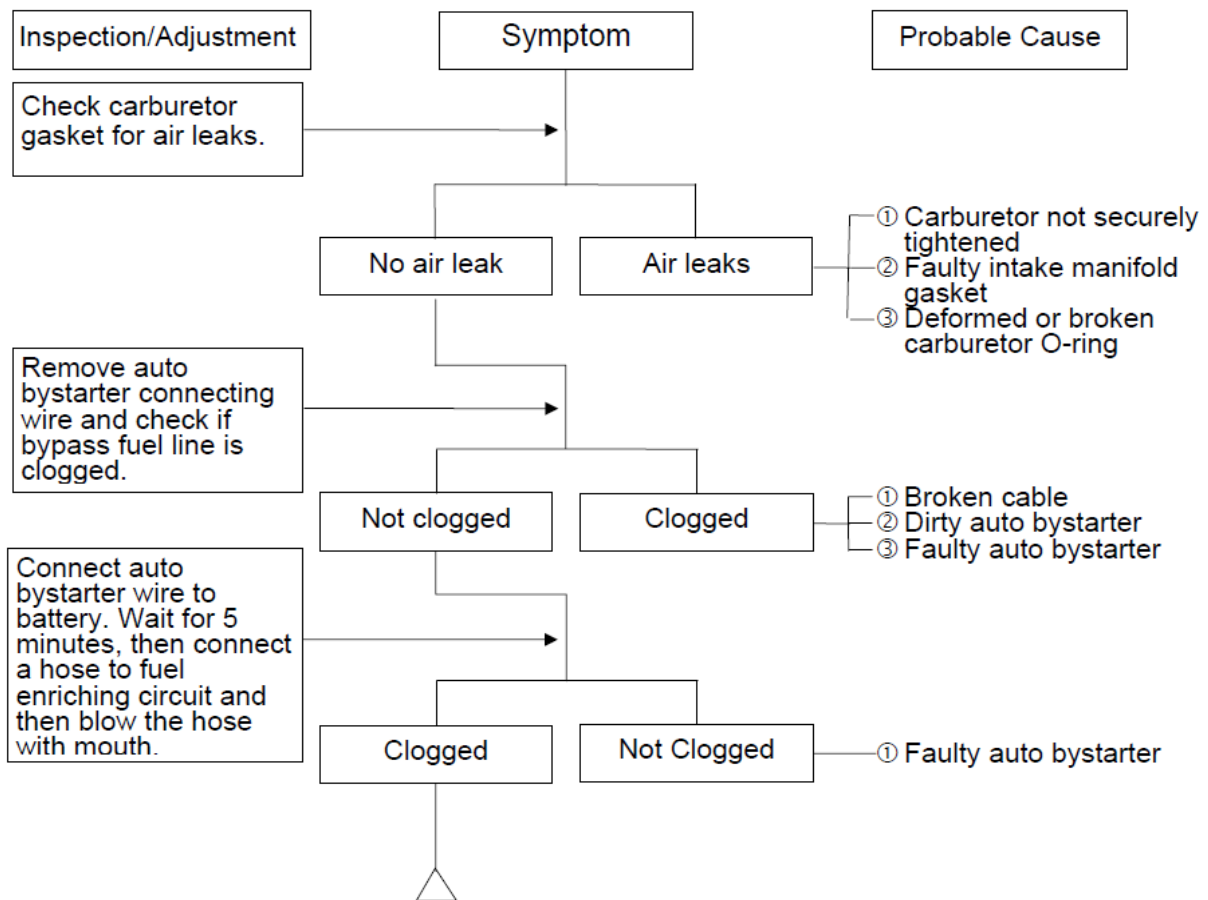

# 1. GENERAL INFORMATION

## ENGINE LACKS POWER

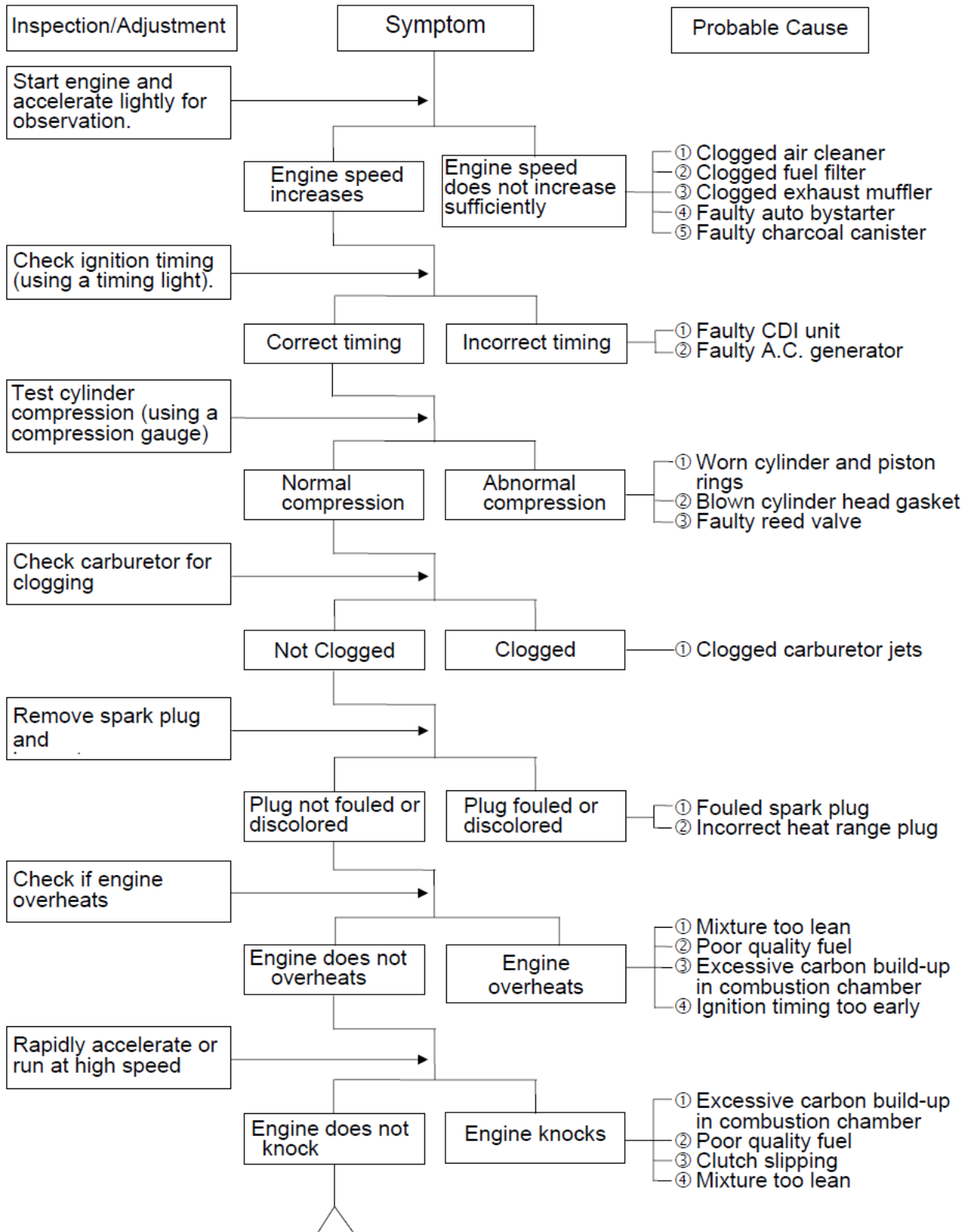

# 1. GENERAL INFORMATION

## POOR PERFORMANCE (ESPECIALLY AT IDLE AND LOW SPEEDS)

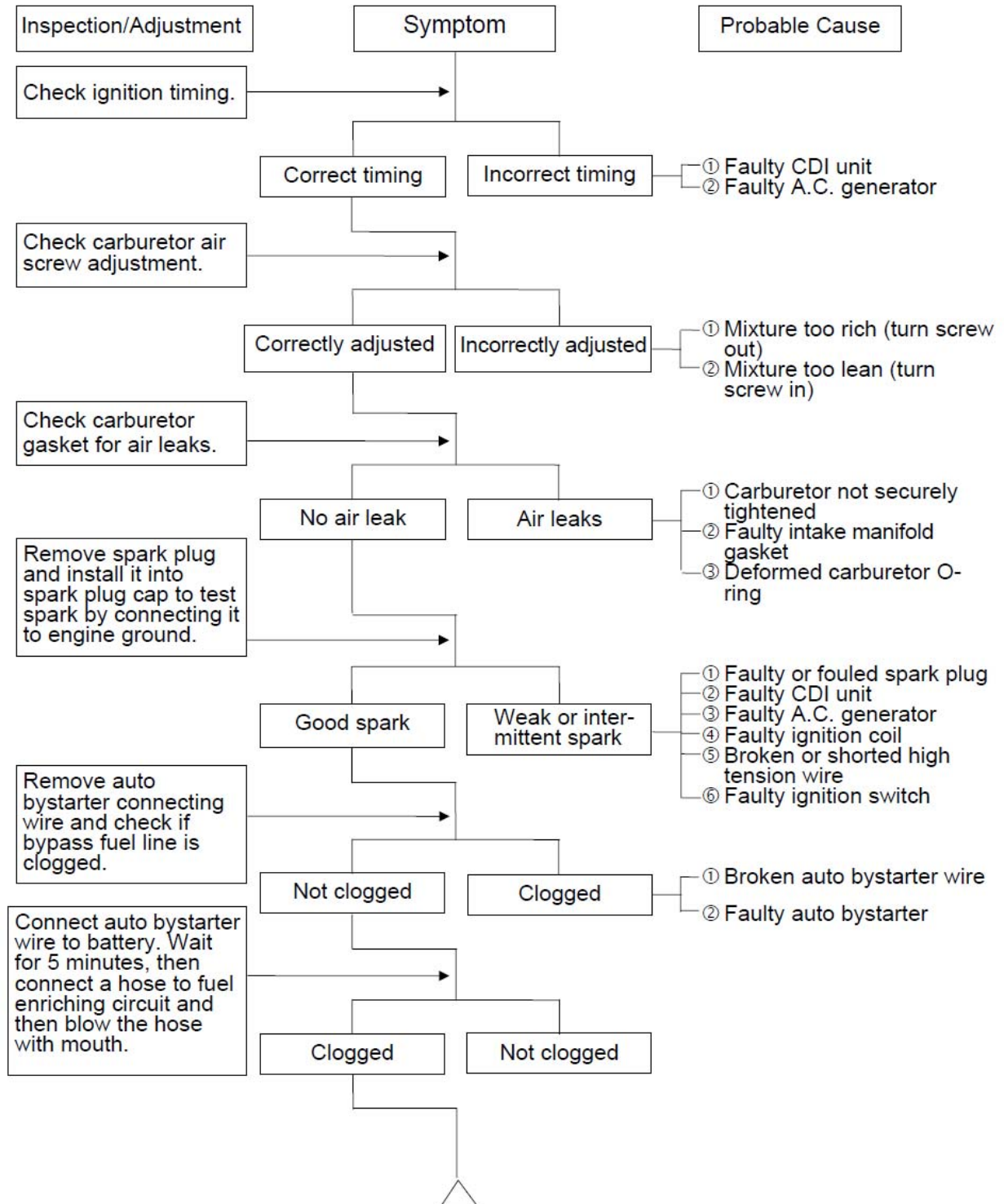

# 1. GENERAL INFORMATION

## POOR PERFORMANCE (AT HIGH SPEED)

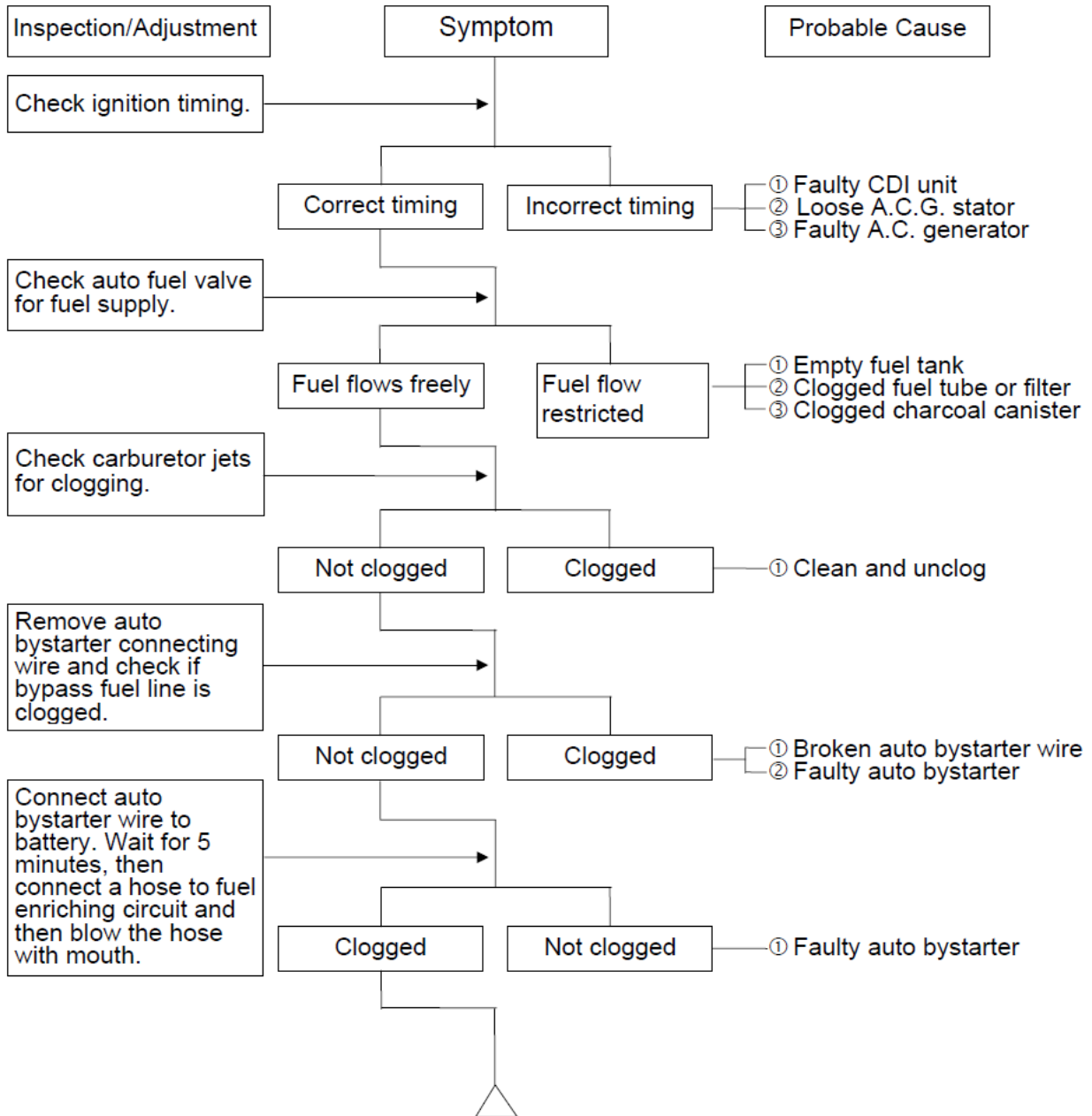

# 1. GENERAL INFORMATION

## CLUTCH, DRIVE AND DRIVEN PULLEYS

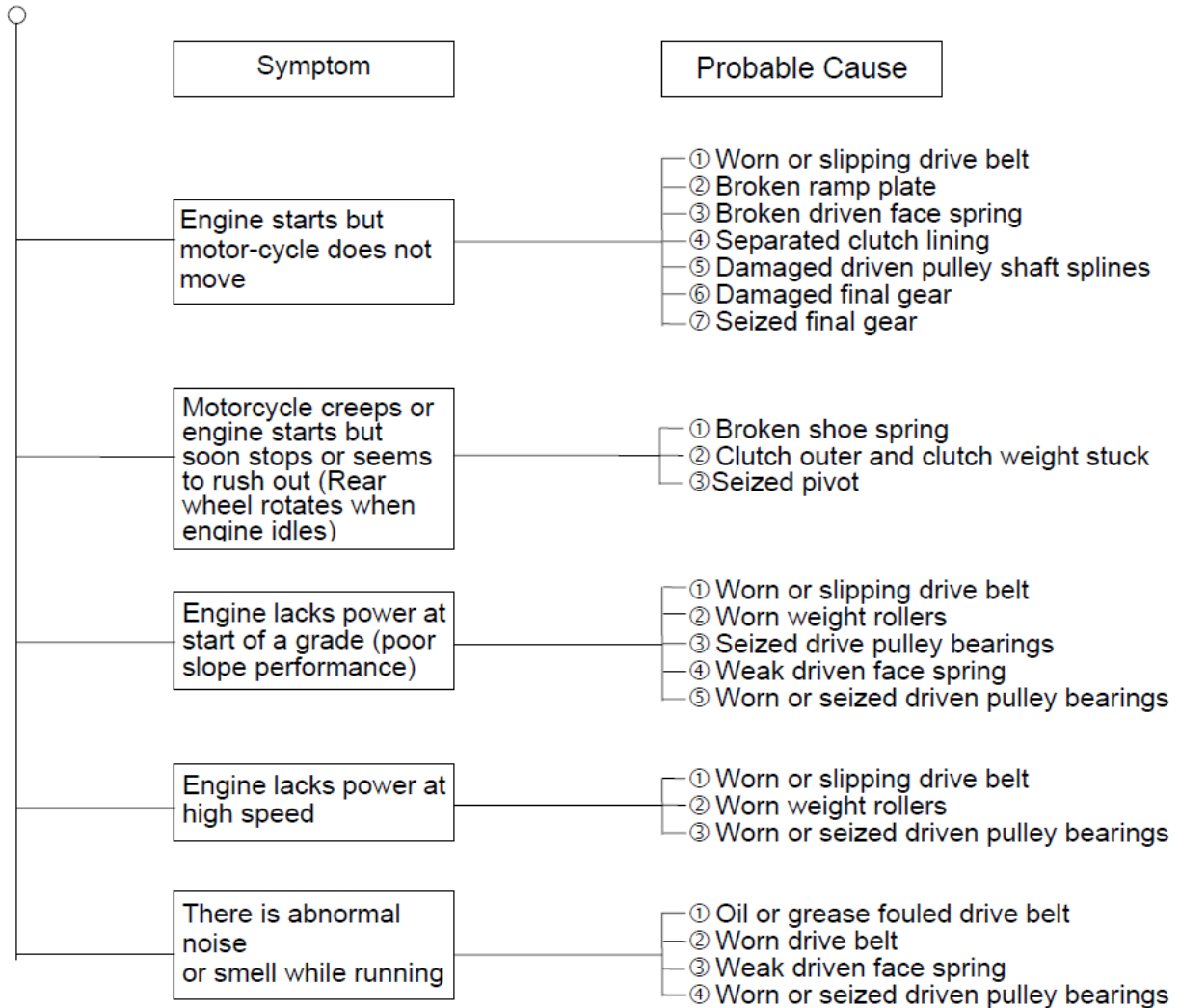

## STEERING HANDLEBAR DOES NOT TRACK STRAIGHT

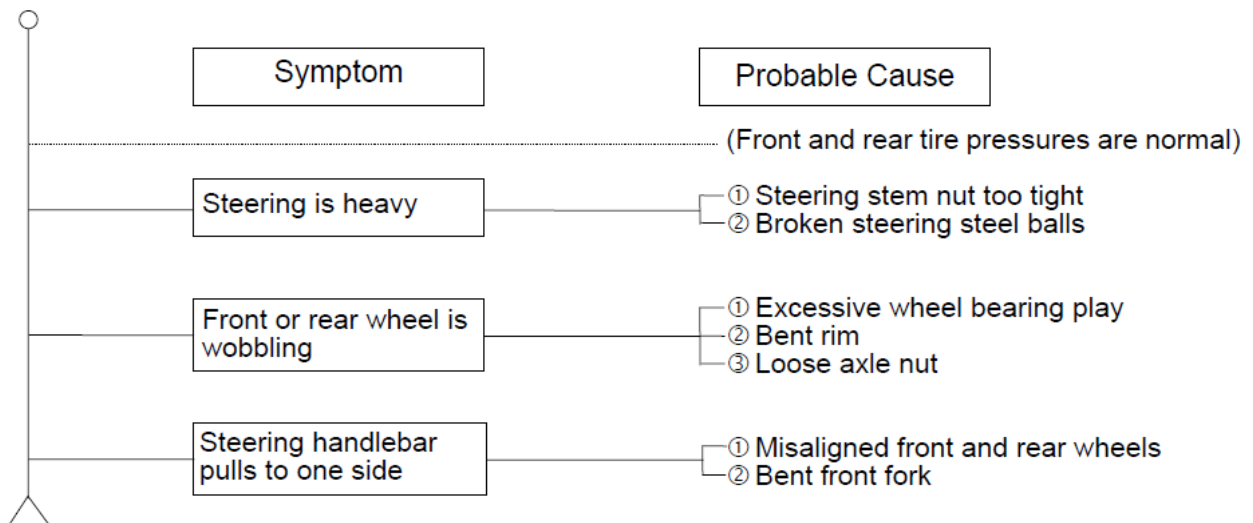

# 1. GENERAL INFORMATION

## POOR SUSPENSION PERFORMANCE

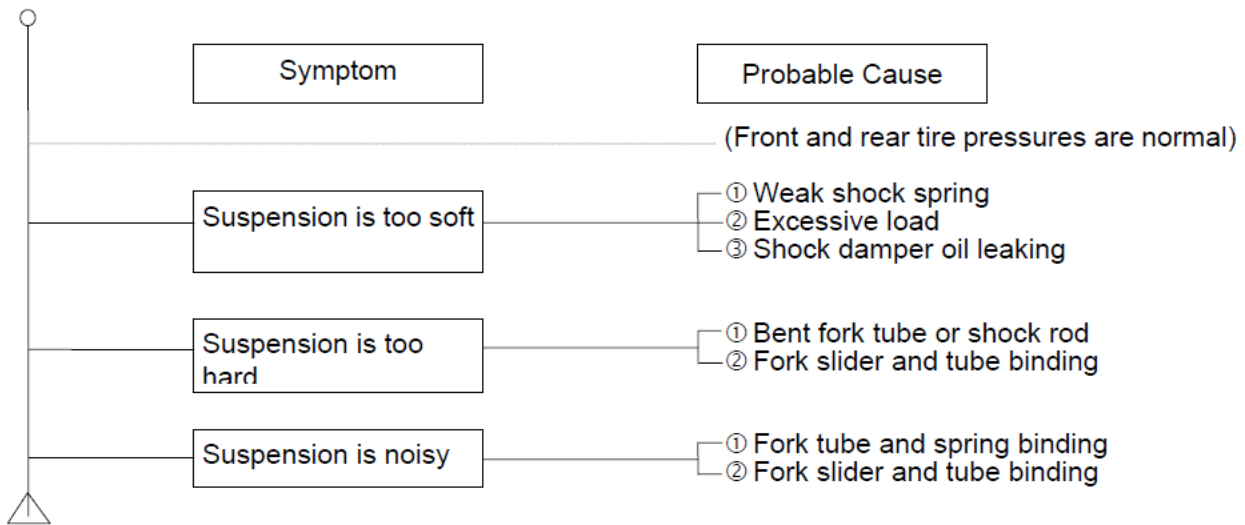

## POOR BRAKE PERFORMANCE

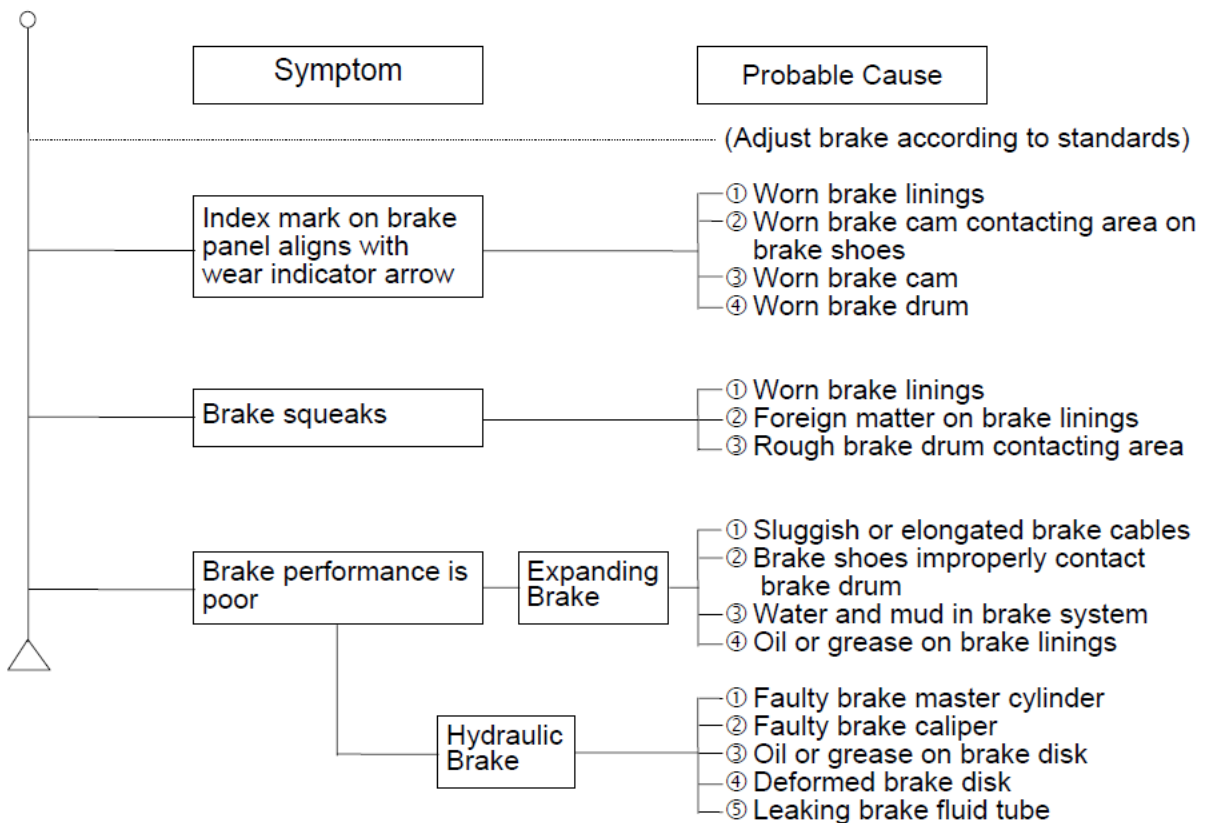

# 1. GENERAL INFORMATION

## STARTER MOTOR

### 1. Starter motor won't turn

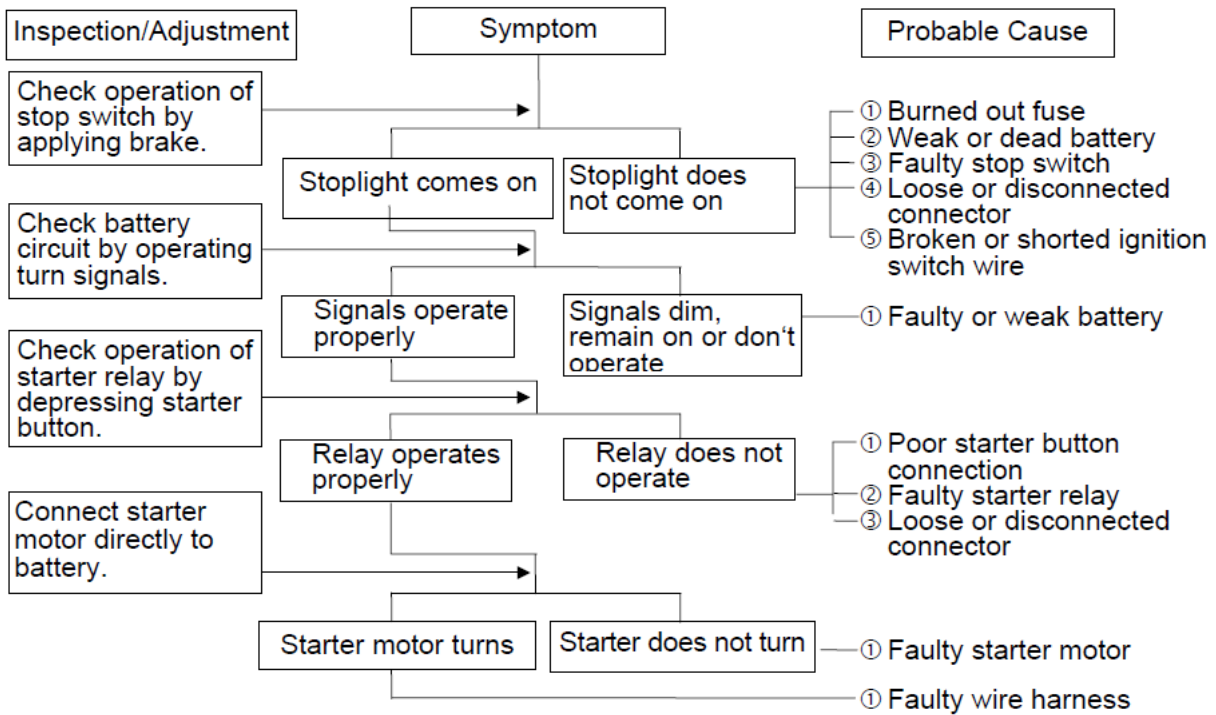

### 2. Starter motor turns slowly or idles

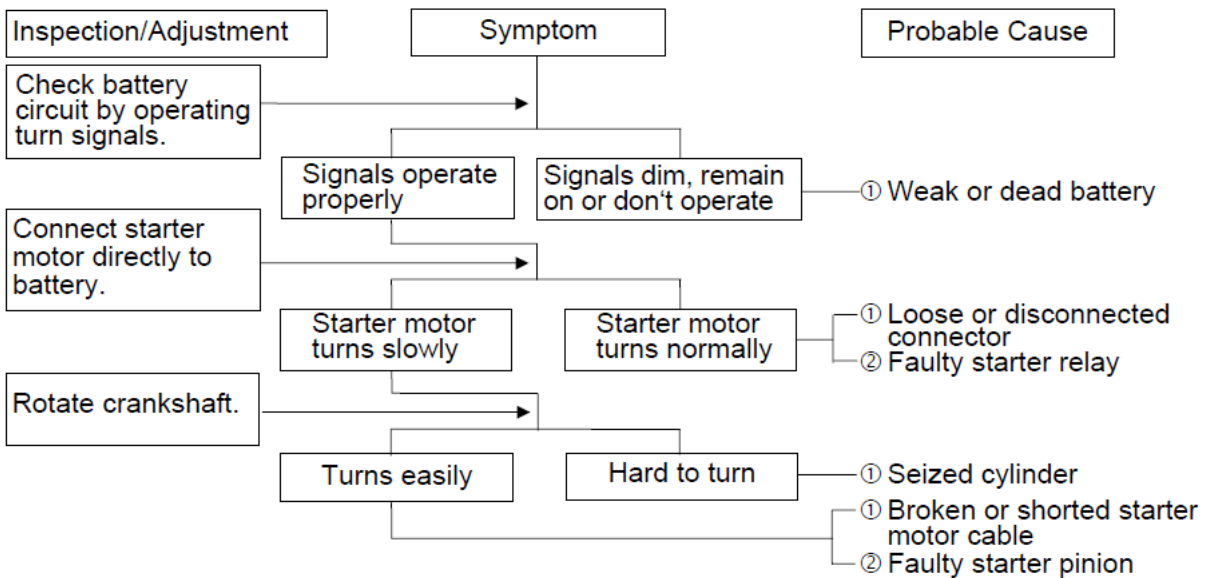

### 3. Starter motor does not stop turning

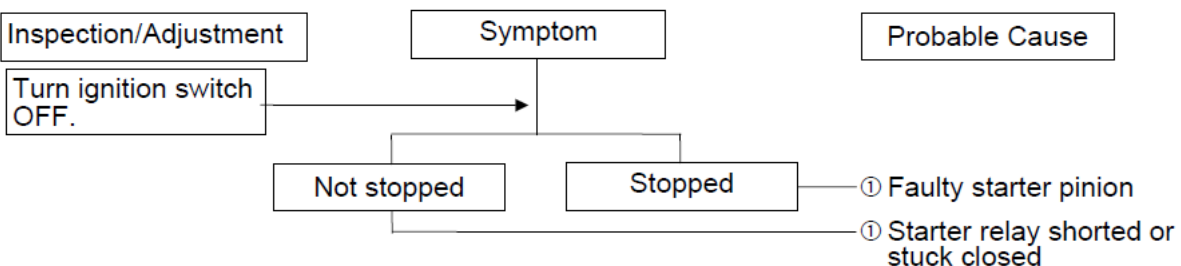

---

## **2. EXHAUST MUFFLER/FRAME COVERS**

---

---

### **EXHAUST MUFFLER/FRAME COVERS**

---

SERVICE INFORMATION-----	2- 1
TROUBLESHOOTING-----	2- 1
FASTENER REMOVAL AND REINSTALLATION-----	2- 2
FRAME COVERS REMOVAL/INSTALLATION-----	2- 3
EXHAUST MUFFLER -----	2-14

## **2. EXHAUST MUFFLER/FRAME COVERS**

### **SERVICE INFORMATION**

#### **GENERAL INSTRUCTIONS**

- When removing frame covers, use care not to pull them by force because the cover joint claws may be damaged.
- Make sure to route cables and harnesses according to the Cable & Harness Routing.

#### **TORQUE VALUES**

Exhaust muffler pipe nuts	1.0~1.4 kgf-m
Exhaust muffler brake	3.0~3.6 kgf-m

### **TROUBLESHOOTING**

#### **Noisy exhaust muffler**

- Damaged exhaust muffler
- Exhaust muffler joint air leaks

#### **Lack of power**

- Caved exhaust muffler
- Clogged exhaust muffler
- Exhaust muffler air leaks

## 2. EXHAUST MUFFLER/FRAME COVERS

### FASTENER REMOVAL AND REINSTALLATION

#### REMOVAL

Depress the head of fastener center piece ①.  
Pull out the fastener.

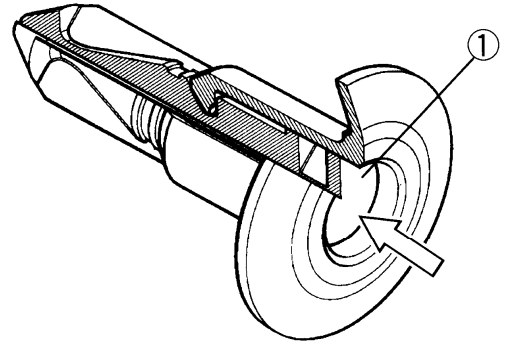

#### INSTALLATION

Let the center piece stick out toward the head so that the pawls ② close.  
Insert the fastener into the installation hole.

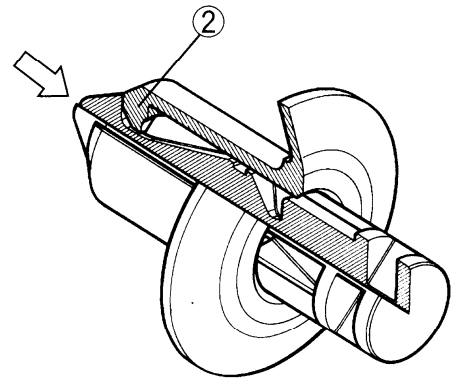

\* To prevent the pawl ② from damage, insert the fastener all the way into the installation hole

Push in the head of center piece until it becomes flush with the fastener outside face.

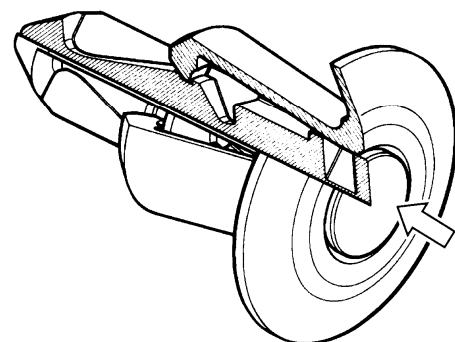

## 2. EXHAUST MUFFLER/FRAME COVERS

---

### FRAME COVERS REMOVAL/ INSTALLATION

#### LUGGAGE BOX

Unlock the seat with the ignition key.  
Open the seat.

Remove the battery cover and battery.

Remove 2 bolts, 2 screws and 4 nuts on the  
luggage box.

Remove the luggage box.



Battery Cover

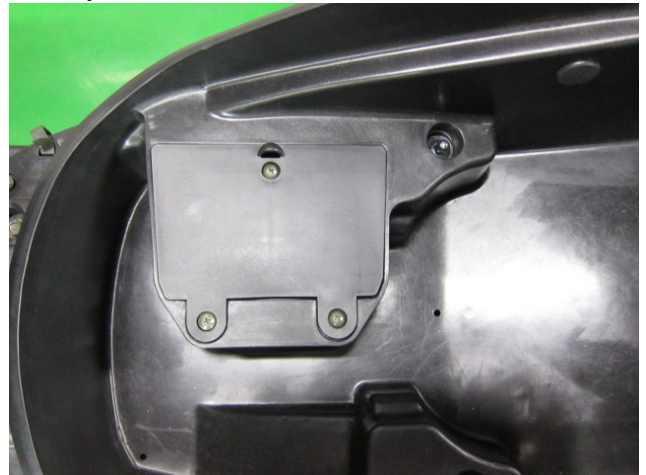

#### SEAT

Unlock the seat with the ignition key.  
Open the seat.

Remove the two nuts and the seat.

Nuts



## 2. EXHAUST MUFFLER/FRAME COVERS

Center Cover

### CENTER COVER

Remove the luggage box and seat.

Remove the center cover.

\* During removal, do not pull the joint claws forcedly to avoid damage.

Installation is in the reverse order of removal.



### REAR CARRIER

Remove 4 bolts and rear carrier

Bolts

Rear carrier

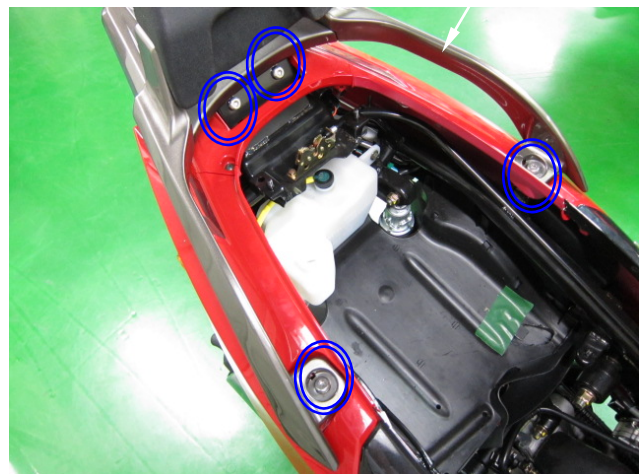

### REAR CENTER COVER

Remove two screws to remove the rear center cover.

Screws

Rear center cover

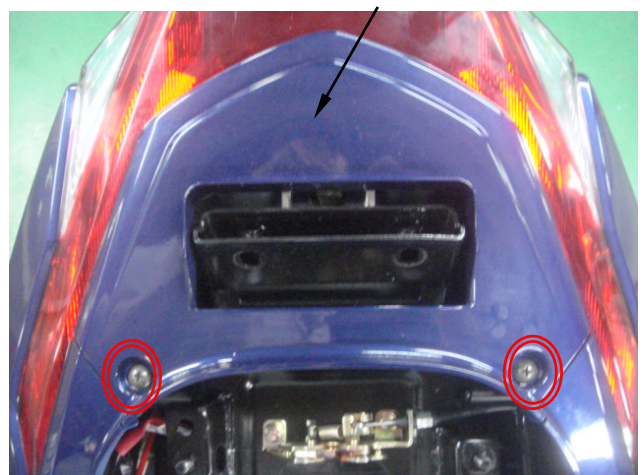

## 2. EXHAUST MUFFLER/FRAME COVERS

### BODY COVER SET

Remove the screws, bolts, nuts and connector to remove the body cover set.

Screws

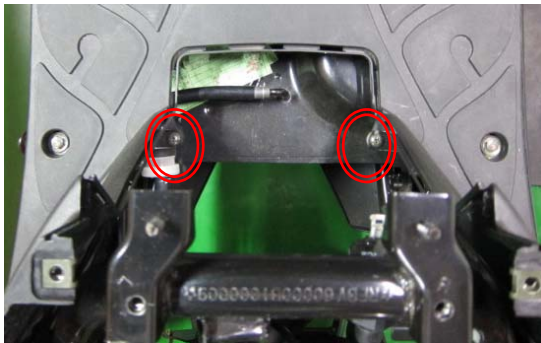

Bolt



Body cover set

Screw



Nuts



Screw



Connector



Dismantle Direction

## 2. EXHAUST MUFFLER/FRAME COVERS

### FRONT SIDE MOLD

Remove the fasteners to remove the right and left of front side molds.

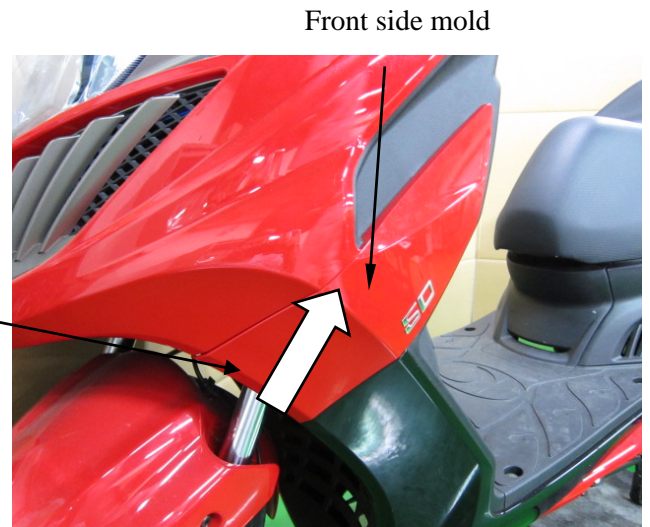

Remove the mat leg shield.

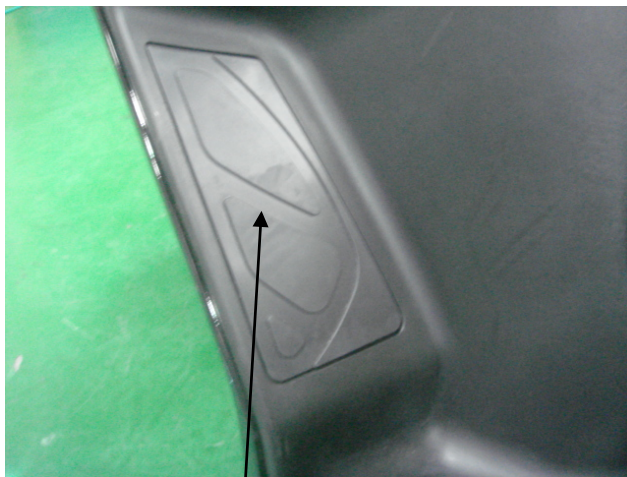

### UNDER COWL

Remove the fasteners and under cowl.

Under cowl

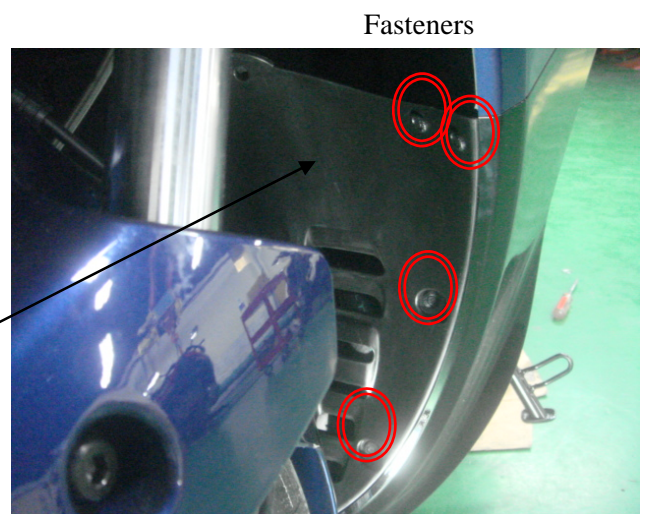

## 2. EXHAUST MUFFLER/FRAME COVERS

### SKIRT SET

Remove the screws and fasteners to remove the right and left skirt sets.



## 2. EXHAUST MUFFLER/FRAME COVERS

### PANEL FLOOR

Remove the bolts and panel floor.

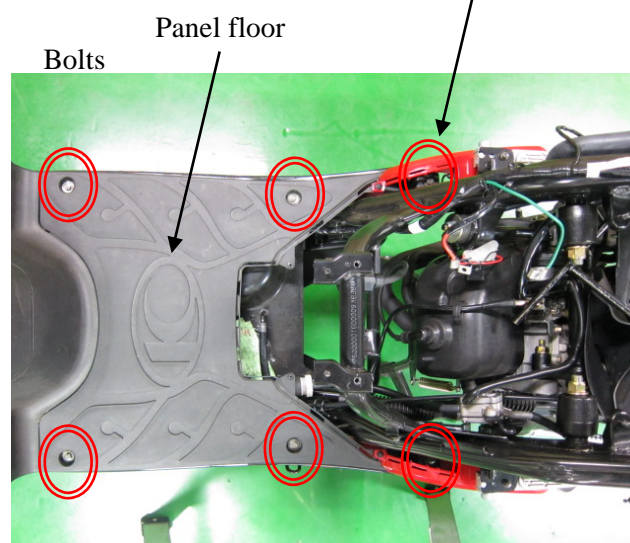

## 2. EXHAUST MUFFLER/FRAME COVERS

---

### HANDLE UP COVER

Remove screws and bolts to remove the handle up cover.

Handle up cover

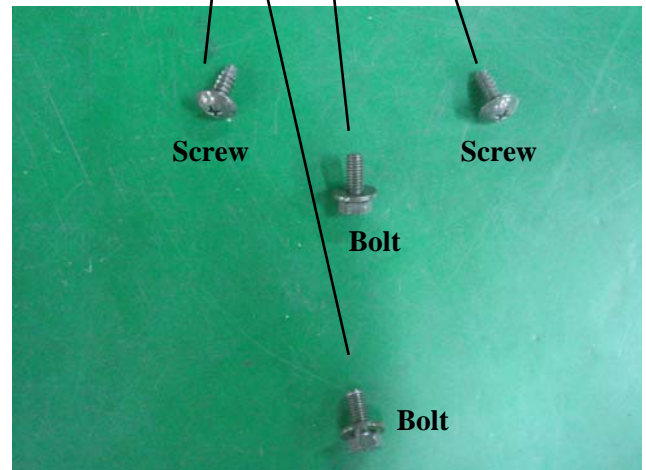
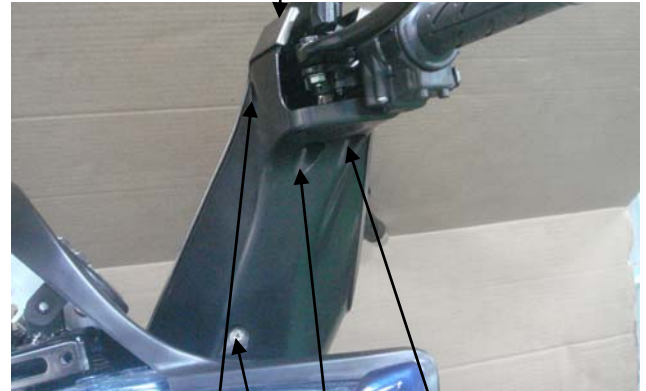

### HANDLE LOW COVER

Remove throttle cables to remove the handle low cover.

Handle low cover



## 2. EXHAUST MUFFLER/FRAME COVERS

---

### WINDSHIELD

Remove five bolts and windshield.

Handle up cover



### FRONT METER COVER SET

Remove the front meter cover.



Front meter cover set.

## 2. EXHAUST MUFFLER/FRAME COVERS

### FRONT COVER SET

Remove the screws, nuts, fasteners and connector to remove the front cover set.

Screws



Nuts



Front cover set



Fastener

Connector



Dismantle  
Direction

## 2. EXHAUST MUFFLER/FRAME COVERS

### REAR METER COVER SET

Remove the fasteners, main switch lid, bolts and connectors to remove the rear meter cover set.

Fasteners



Rear meter cover set

Main switch lid

Bolts

Connectors



## 2. EXHAUST MUFFLER/FRAME COVERS

### LEG SHIELD SET

Remove the screws, bolt, center clip, connector and fuel filler cap to remove the leg shield.

Connector



Leg shield set



Screws

Center clip

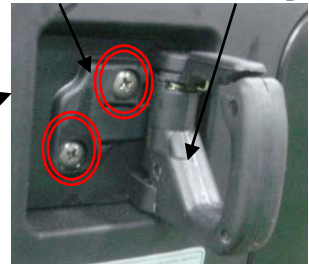

Bolt



Bolts

Fuel filler cap



## 2. EXHAUST MUFFLER/FRAME COVERS

### FRONT INNER FENDER

Remove the bolts, fasteners to remove the front inner fender.

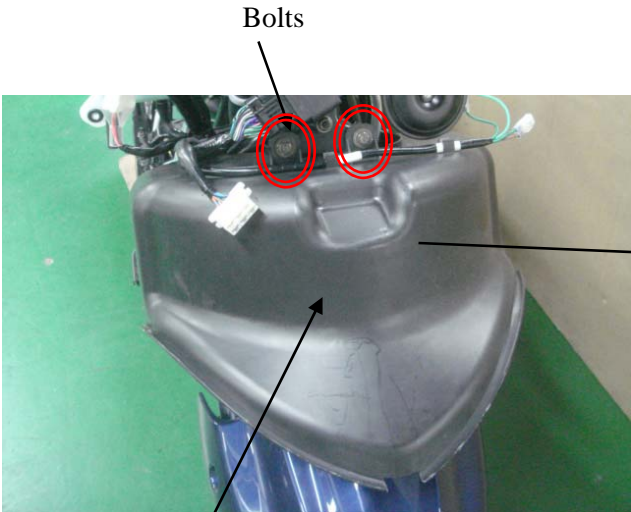

### FRONT FENDER

Remove the bolts to remove the front fender.

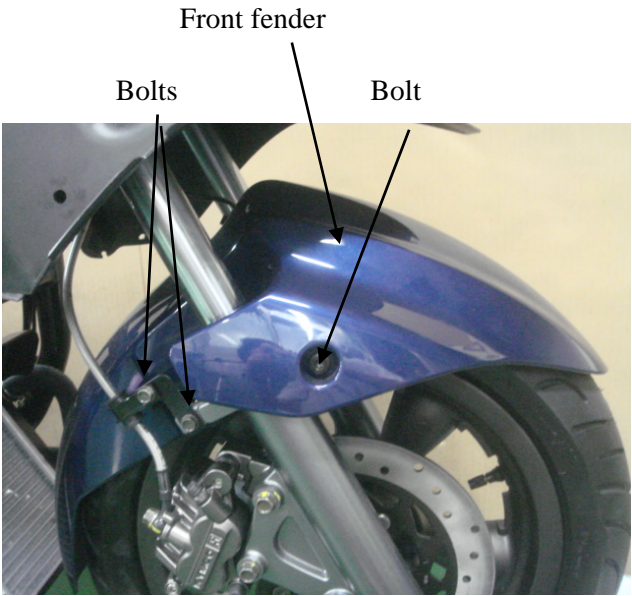
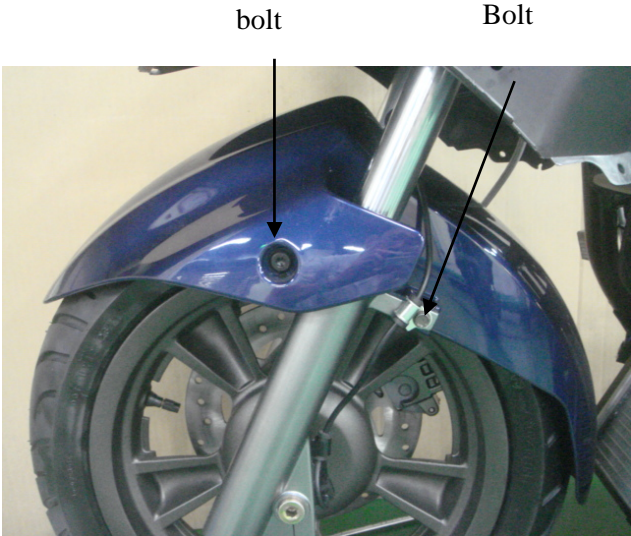

## 2. EXHAUST MUFFLER/FRAME COVERS

---

### EXHAUST MUFFLER

#### REMOVAL

Remove the bolts to remove the muffler.



Bolts

Muffler

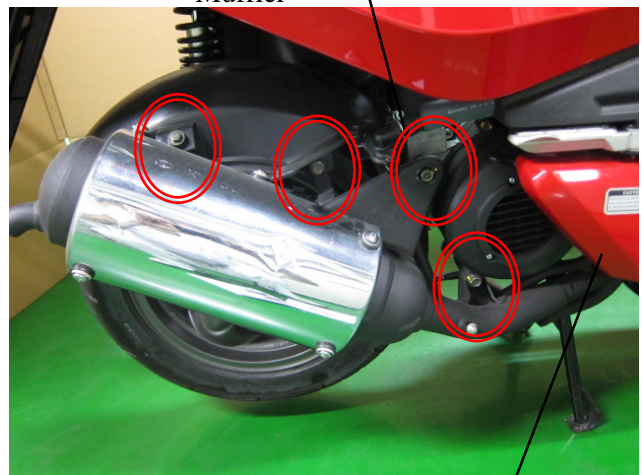

Installation is in the reverse order of removal.

Nuts

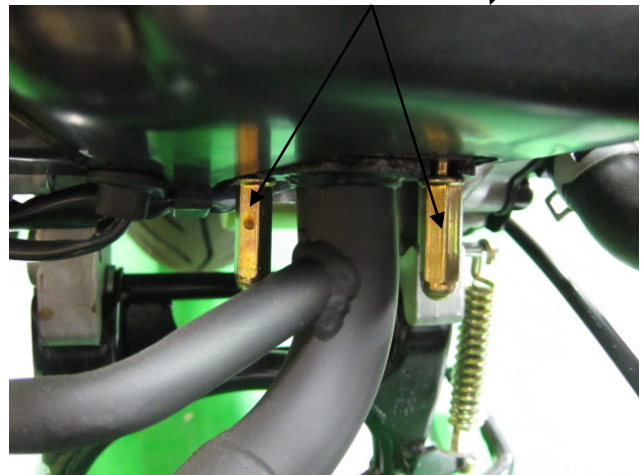

# 3. INSPECTION/ADJUSTMENT

---

**3**

---

## INSPECTION / ADJUSTMENT

---

SERVICE INFORMATION-----	3- 1
MAINTENANCE SCHEDULE-----	3- 2
BRAKE SYSTEM -----	3- 3
CLUTCH SHOE WEAR -----	3- 5
SUSPENSION-----	3- 5
NUTS/BOLTS/FASTENERS-----	3- 6
WHEELS/TIRES -----	3- 6
STEERING HANDLEBAR -----	3- 6
ELECTRICAL EQUIPMENT -----	3- 7
AIR CLEANER -----	3- 8
OIL PUMP CONDITION-----	3-10

### 3. INSPECTION/ADJUSTMENT

#### SERVICE INFORMATION

##### GENERAL

 **WARNING**

- Before running the engine, make sure that the working area is well ventilated. Never run the engine in a closed area. The exhaust contains poisonous carbon monoxide gas, which may cause death to people.
- Gasoline is extremely flammable and is explosive under some conditions. The working area must be well ventilated and do not smoke or allow flames or sparks near the working area or fuel storage area.

##### SPECIFICATIONS

###### ENGINE

- Throttle grip free play : 2~6 mm
- Spark plug : NGK CR7HSA
- Spark plug gap : 0.6 mm ~ 0.7 mm
- Valve clearance : IN: 0.10 mm EX: 0.10 mm
- Idle speed : 1700±100 rpm

###### Engine oil capacity:

Cylinder compression: 18±2 kg/cm<sup>2</sup>

###### Gear oil capacity :

- At disassembly : 0.23 Liter
- At change : 0.18 Liter

##### TIRE

	1 Rider	2 Riders
Front	1.75 kg/cm <sup>2</sup>	1.75 kg/cm <sup>2</sup>
Rear	2.0 kg/cm <sup>2</sup>	2.25 kg/cm <sup>2</sup>

##### TIRE SPECIFICATION

- Front : 120/70-13
- Rear : 140/70-12

##### TORQUE VALUES

- Front axle nut : 2 kg-m
- Rear axle nut : 12 kg-m

##### SPECIAL TOOL

- Tappet Adjuster E012

### 3. INSPECTION/ADJUSTMENT

#### MAINTENANCE SCHEDULE

##### Maintenance schedule

Perform the pre-ride inspection Page. 18 at each scheduled maintenance period. This interval should be judged by odometer reading or months, whichever comes first.

##### Maintenance schedule legend

I: INSPECT AND CLEAN, ADJUST, LUBRICATE OR REPLACE IF NECESSARY

C: CLEAN R: REPLACE A: ADJUST L: LUBRICATE T: TIGHTEN

The maintenance schedule on page 25 specifies the maintenance required to keep your Super 8 scooter in peak operating condition. Maintenance work should be performed in accordance with KYMCO standards and specifications by properly trained and equipped technicians. Your KYMCO dealer meets all of these requirements.

\* Should be serviced by your KYMCO dealer, unless you have the proper tools, service data and are technically qualified.

\*\* In the interest of safety, we recommend these items be serviced only by your KYMCO dealer. KYMCO USA recommends that your KYMCO dealer road test your scooter after each periodic maintenance service is completed.

##### Maintenance schedule notes

1. At higher odometer readings, repeat at the frequency interval listed here.
2. Service more frequently if the scooter is ridden in unusually wet or dusty areas.
3. Service more frequently when riding in rain or at full throttle.
4. "PRI" indicates that the item should be checked as part of the Pre-ride Inspection
5. "See page" indicates on which page of the Owner's Manual you will find information about the required maintenance.
6. "Dealer" indicates maintenance or service procedure that should be performed by your KYMCO dealer.

ITEM	MILEAGE							
	200 mi 300 km	600 mi 1000 km	1850 mi 3000 km	3100 mi 5000 km	4300 mi 7000 km	5500 mi 9000 km	7000 mi 11000 km	Pre-ride inspection
Engine oil *	Refill whenever the low oil level indicator is illuminated							PRI
Gear oil *	R	-	R	-	R	-	R	-
Spark plug *	C	I	C	R	C	I	R	-
Carburetor **	I	-	I	-	I	-	I	-
Drive belt **	-	-	-	-	I	-	-	-
Air cleaner *	C	I	C	I	C	I	C	-
Battery *	I	I	I	I	I	I	I	PRI
Fuel filter **	-	-	-	-	R	-	-	-
Brake system **	I	I	I	I	I	I	I	PRI
Tires **	I	I	I	I	I	I	I	PRI
Bolts & nuts *	T	I	I	T	I	I	T	PRI

I: INSPECT AND CLEAN, ADJUST, LUBRICATE OR REPLACE IF NECESSARY

C: CLEAN R: REPLACE A: ADJUST L: LUBRICATE T: TIGHTEN

### 3. INSPECTION/ADJUSTMENT

#### BRAKE SYSTEM

#### BRAKE LEVER

Measure the front and rear brake lever free plays.

**Free Play:** Rear: 10~20mm

Rear 10~20mm

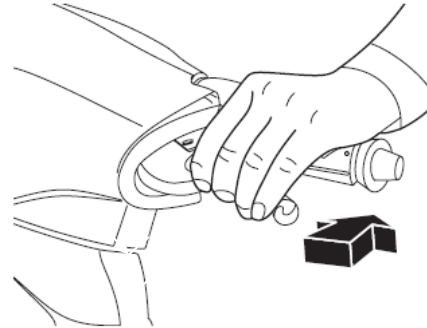

If the free plays do not fall within the limits, turn the right and left adjusting nuts for adjustment.

<Rear>

“△” Marks

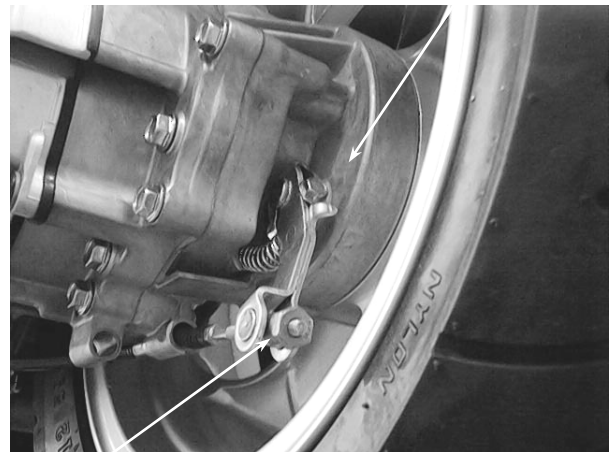

Adjusting Nuts

### 3. INSPECTION/ADJUSTMENT

#### BRAKE DRUM/SHOE

##### 《 Brake Shoe Wear 》

Replace the brake shoes if the arrow on the brake arm aligns with reference mark“△” on the brake panel when the brake is fully applied.

##### 《 Brake Drum Wear/Damage 》

Check the brake drum appearance for damage. Check if the brake lining wear is within the specified service limit. Check the brake operation for abnormal noise and brake drum inside for wear or damage.

<Rear>

“△” Marks

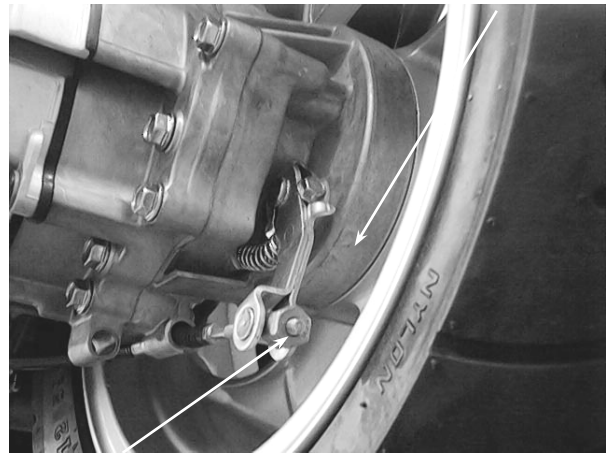

Adjusting Nuts

#### BRAKE DISK/BRAKE PAD

Check the brake disk surface for scratches, unevenness or abnormal wear. Check if the brake disk runout is within the specified service limit. Check if the brake pad wear exceeds the wear indicator line.

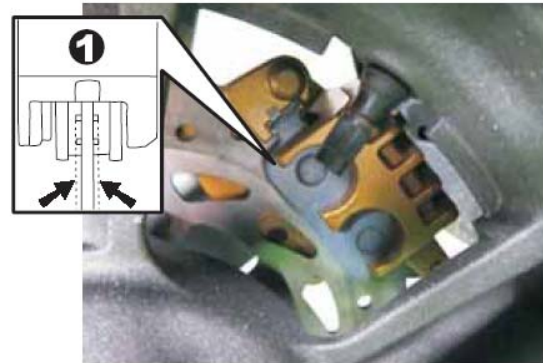

\* Keep grease or oil off the brake disk to avoid brake failure.

#### BRAKE FLUID

Turn the steering handlebar upright and check if both brake fluid levels is at the upper limit. If the brake fluid is insufficient, fill to the upper limit.

Specified Brake Fluid: DOT-4



\* The brake fluid level will decrease if the brake pads are worn.

### 3. INSPECTION/ADJUSTMENT

#### CLUTCH SHOE WEAR

Start engine and check the clutch operation by increasing the engine speed gradually. If the motorcycle tends to creep or the engine stop, check the clutch shoes for wear and replace if necessary.

#### SUSPENSION

##### FRONT

Check the action of the front shock absorbers by compressing them several times.

Check the entire shock absorber assembly for oil leaks, looseness or damage.

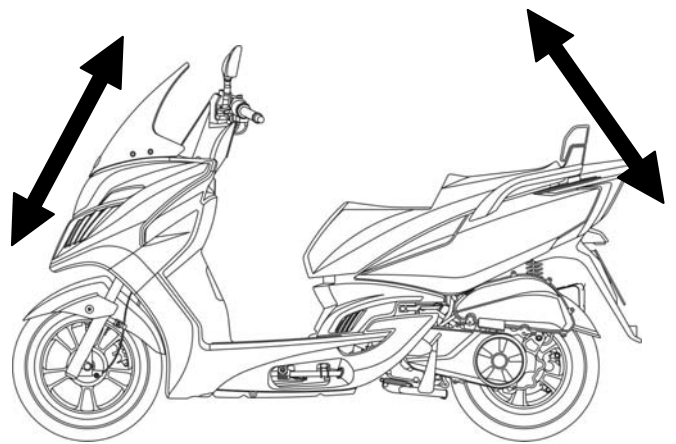

##### REAR

Each shock absorber(4) on your scooter has 5 spring preload adjustment positions for different load or riding conditions.

Use a pin spanner(5) to adjust the rear shock spring preload. Position 1 is for light loads and smooth road conditions. Position 3 to 5 increase spring preload for a stiffer rear suspension and can be used when the scooter is heavily loaded.

Be certain to adjust both shock absorbers to the same spring preload positions.

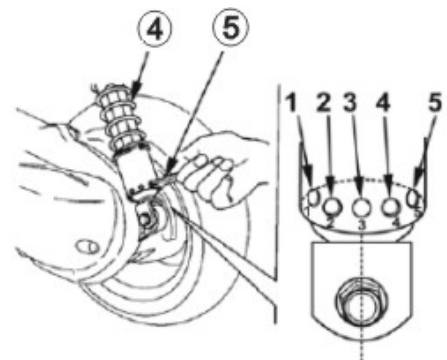

### 3. INSPECTION/ADJUSTMENT

#### NUTS/BOLTS/FASTENERS

Check all important chassis nuts and bolts for looseness.  
Tighten them to their specified torque values if any looseness is found.

#### WHEELS/TIRES

Check the tires for cuts, imbedded nails or other damages.  
Check the tire pressure.

- \* • Tire pressure should be checked when tires are cold.

#### Tire Pressure

	1 Rider	1 Rider (with passenger)
Front	2 kg/cm <sup>2</sup>	2 kg/cm <sup>2</sup>
Rear	2.25 kg/cm <sup>2</sup>	2.25 kg/cm <sup>2</sup>

#### Tire Size:

Front 120/70-13  
Rear 130/70-12

Check the front axle nut for looseness.  
Check the rear axle nut for looseness.  
If the axle nuts are loose, tighten them to the specified torques.

#### Torque:

Front axle nut 2 kg-m  
Rear axle nut 12 kg-m

#### STEERING HANDLEBAR

Raise the front wheel off the ground and check that the steering handlebar rotates freely.  
If the handlebar moves unevenly, binds, or has vertical movement, adjust the steering head bearing.

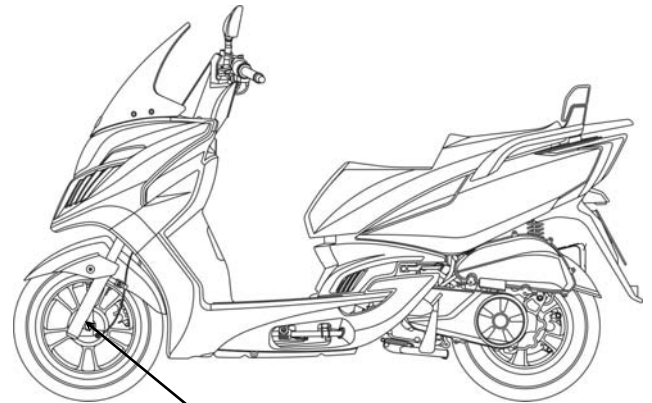
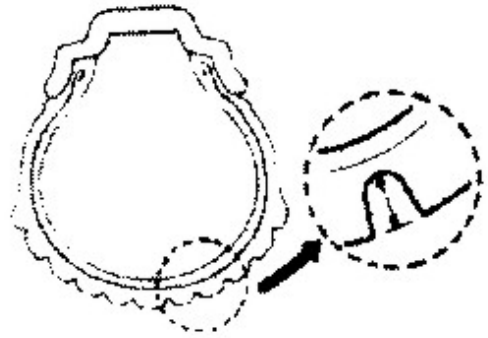

Front Axle Nut

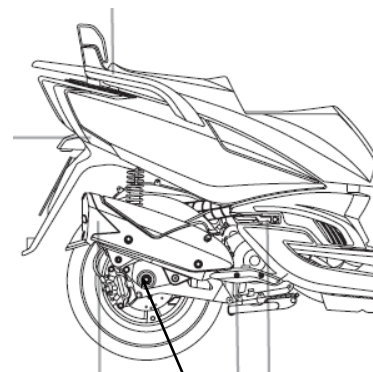

Rear Axle Nut

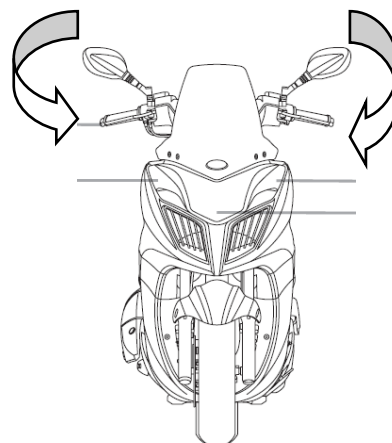

### 3. INSPECTION/ADJUSTMENT

#### ELECTRICAL EQUIPMENT

#### IGNITION APPARATUS

##### 《Spark Plug》

Remove the frame center cover.  
Remove the spark plug cap and spark plug.  
Check the spark plug for wear, fouling and carbon deposits.  
Remove the fouling and carbon deposits with a spark plug cleaner or wire brush.

##### Specified Spark Plug:

NGK
CR7HSA

**Spark Plug Gap:** 0.6~0.7mm

##### 《Ignition Apparatus》

\* The CDI ignition timing is not adjustable. If the timing is incorrect, check the CDI unit, ignition coil and A.C. generator and replace any faulty

Remove the right side rail.  
Remove the A.C. generator fan cover.

Remove the three bolts attaching the fan cover and then remove the fan cover.  
Warm up the engine and check the ignition timing with a timing light.

When the engine is running at the specified rpm, the ignition timing is correct if the "F" mark on the flywheel aligns with the index mark on the crankcase within  $\pm 1.5^\circ$ .

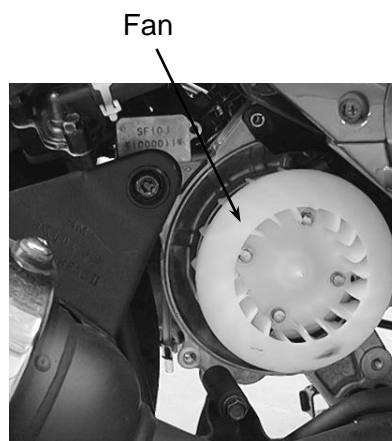
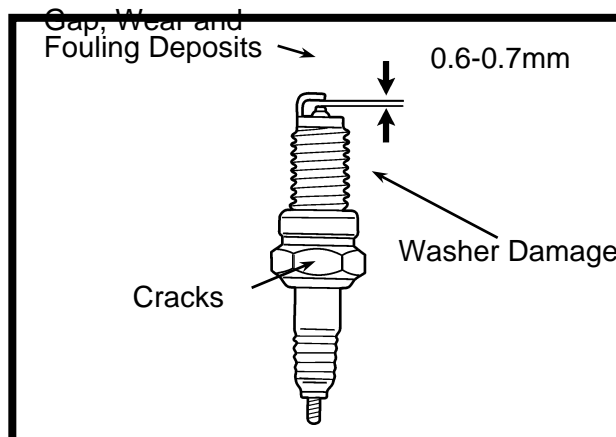

### 3. INSPECTION/ADJUSTMENT

#### 《Air Cleaner》

Remove the air cleaner cover by removing the seven bolts cleaner cover screws.

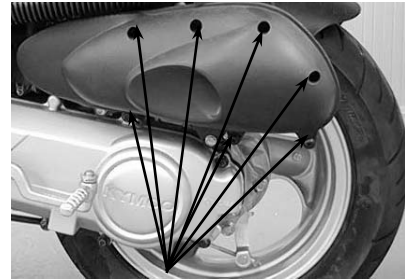

Screws

Remove the air cleaner element.



Air Cleaner

### 3. INSPECTION/ADJUSTMENT

Wash the air cleaner element in detergent oil, squeeze out and allow to dry.

\* Never use gasoline or organic vaporable oil with acid or alkali for washing.

After washing, soak the element in clean engine oil SAE 15W-40# and squeeze out excess oil. Reinstall the element.

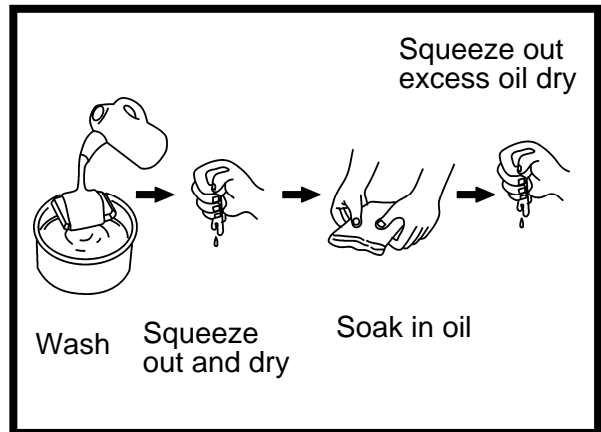

#### 《Cylinder Compression》

\* Warm up the engine before compression test.

Remove the spark plug and insert a compression gauge. Open the throttle valve fully and push the starter button for 7~8 seconds to test the compression.

Compression:

11.8kg/cm<sup>2</sup>

If the compression is low, check for the following:

- Leaking cylinder head gasket
- Worn piston/cylinder

If the compression is high, it indicates that carbon deposits have accumulated on the combustion chamber and the piston head.



#### LUBRICATION SYSTEM

##### 《Oil Filter Cleaning》

Disconnect the oil tube at the oil pump side and allow oil to drain into a clean container. Remove the tube clip at the oil tank side and disconnect the oil tube. Remove the oil filter.

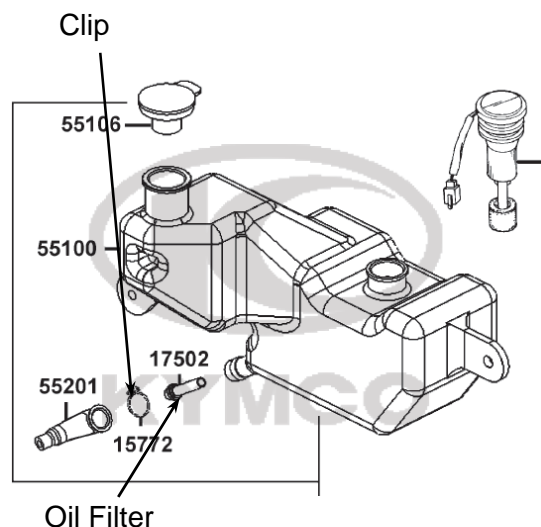

### 3. INSPECTION/ADJUSTMENT

Clean the oil filter screen with compressed air.  
Install the oil filter in the reverse order of removal and fill the oil tank with specified oil up to the proper level.  
Bleed air from the oil pump and oil lines.

\* \_\_\_\_\_

- Connect the oil tubes securely.
- Install the tube clip at the oil tank side and also install the clip to the lower oil tube that goes to the oil pump.
- Check for oil leaks.

Filter Screen

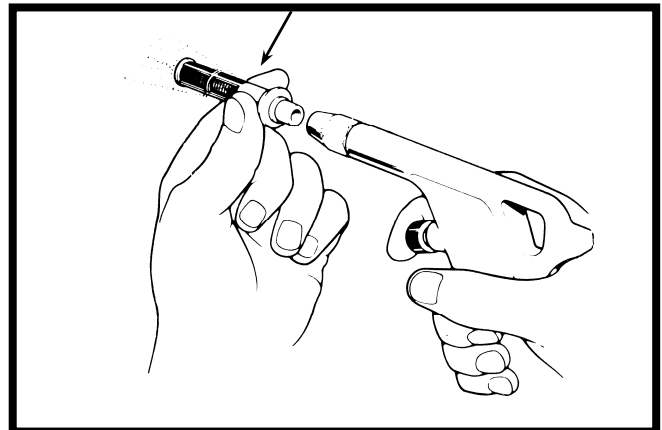

#### 《Oil Pump Condition》

\* \_\_\_\_\_

Adjust oil pump control cable after the throttle grip free play is adjusted.

Open the throttle valve fully and check that the index mark on the pump body aligns with the aligning mark on the oil pump control lever.

Reference tip alignment within 1mm of index mark on open side is acceptable.

Start and idle the engine, then slowly open the throttle to increase engine rpm and check the operation of the oil pump control lever.

If adjustment is necessary, adjust the oil pump control cable by loosening the control cable lock nut and turning the adjusting nut. After adjustment, tighten the lock nut.

\* \_\_\_\_\_

Reference tip alignment within 1mm of index mark on open side is acceptable. However, the aligning mark on the control lever must never be on the closed side of the index mark, otherwise engine damage will occur because of insufficient lubrication.

Lock Nut      Control Lever Aligning Mark



Adjusting Nut

Pump Body Index Mark

If the oil pump is not synchronized properly, the following will occur:

- Excessive white smoke or hard starting due to pump control lever excessively open
- Seized piston due to pump control lever insufficiently open

---

**LUBRICATION SYSTEM**

---

SERVICE INFORMATION ..... 4-2

TROUBLESHOOTING ..... 4-2

OIL PUMP REMOVAL ..... 4-3

OIL PUMP INSPECTION ..... 4-3

OIL PUMP INSTALLATION ..... 4-4

OIL PUMP BLEEDING ..... 4-5

OIL TANK ..... 4-6

## LUBRICATION SYSTEM

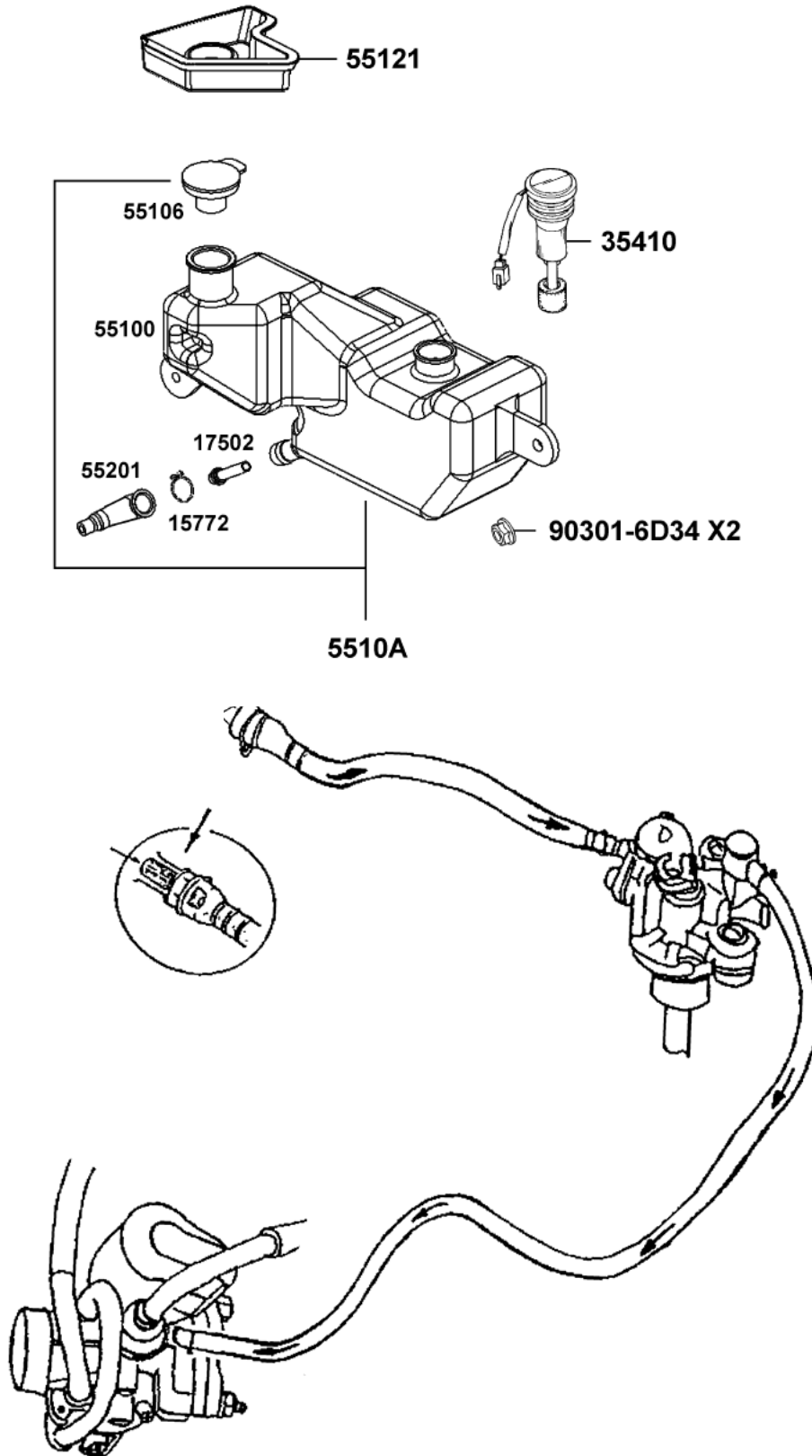

### SERVICE INFORMATION

#### GENERAL INSTRUCTIONS

- Use care when removing and installing the oil pump not to allow dust and dirt to enter the engine and oil line.
- Do not attempt to disassemble the oil pump.
- Bleed air from the oil pump if there is air between the oil pump and oil line.
- If the oil is disconnected, refill the oil line with motor oil before connecting it.

#### SPECIFICATIONS

- Recommended Motor Oil: 2-stroke Motor Oil
- Oil Capacity : 1.1 liter

#### TROUBLESHOOTING

##### Excessive white smoke or carbon deposits on spark plug

- Oil pump not properly synchronized (excessive oil)
- Poor quality oil

##### Engine overheating

- Oil pump not properly adjusted (insufficient oiling)
- Poor quality oil

##### Seized piston

- No oil in tank or clogged oil line
- Oil pump not properly adjusted (insufficient oiling)
- Air in oil line
- Faulty oil pump

##### Oil not flowing out of tank to engine

- Clogged oil tank cap breather hole
- Clogged oil filter

### OIL PUMP REMOVAL

- \* Do not allow foreign matters to enter the crankcase. Before removing the oil pump, clean the oil pump and crankcase surfaces.

Remove the met-in box.

Disconnect the oil pump control cable from the pump body.  
Disconnect the oil inlet line from the oil pump.  
Then, disconnect the oil outlet line.

- \* Before disconnecting the oil line, clip the oil line to avoid oil flowing out and then plug the oil line after it is disconnected.

Remove the oil pump control cable plate bolt.  
Remove the oil pump from the crankcase.

### OIL PUMP INSPECTION

Remove the oil pump and inspect the following items:

- Weakened O-ring
- Damage to crankcase mating surface
- Damage to pump body
- Control lever operation
- Oil leaks through oil seals
- Worn or damaged pump pinion

- \* Do not disassemble the oil pump which cannot be used after disassembly.

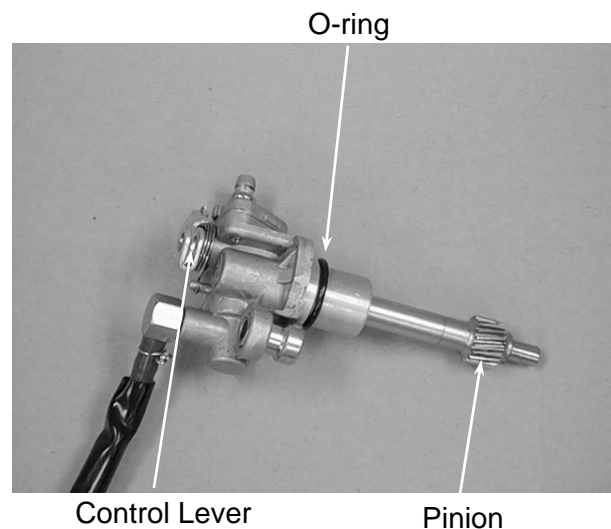
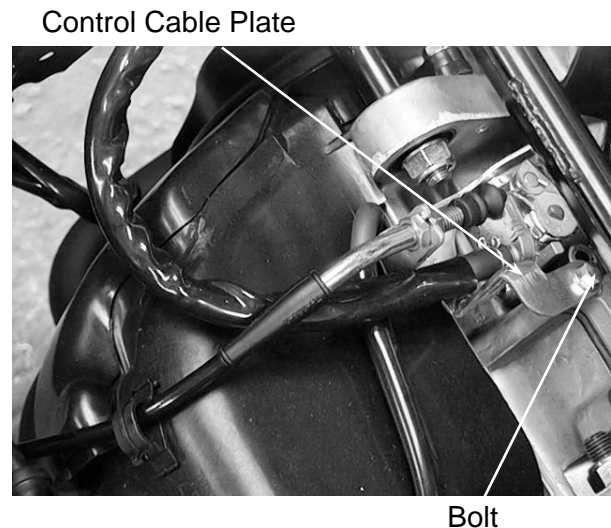
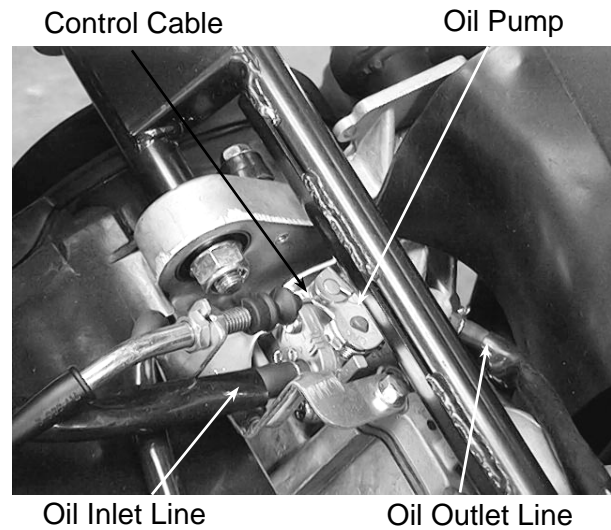

## OIL PUMP INSTALLATION

\*

- Lubricate the O-ring with grease or engine oil before installation.
- Make sure that the oil pump is inserted into the crankcase.
- Apply molybdenum disulfide or grease to the pump pinion.

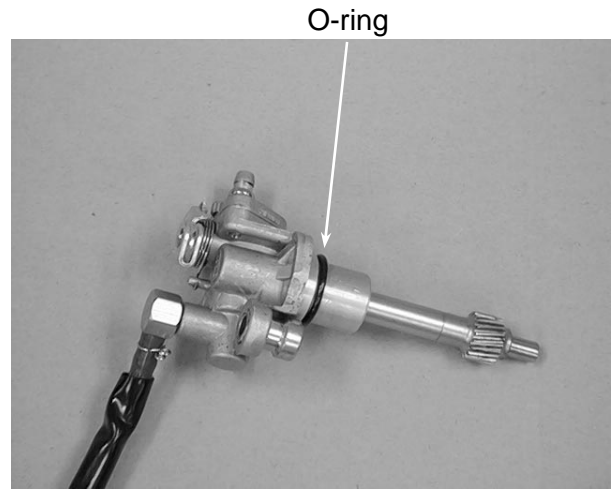

Install the oil pump onto the crankcase.

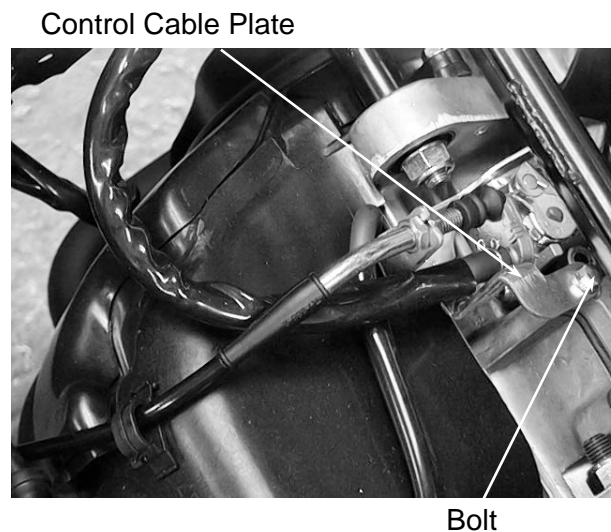

Install the oil pump control cable plate.  
Connect the oil inlet line and oil outlet line properly.  
Connect the oil pump control cable.  
Bleed air from the oil pump.

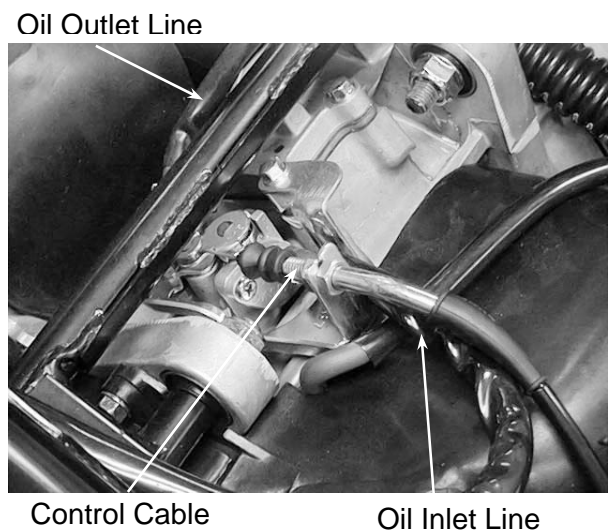

### OIL PUMP BLEEDING

\*

- Air in the oil lines will block oil flow and result in severe engine damage.
- Bleed air from the oil lines and oil pump whenever the oil lines or pump have been removed or there is air in the oil lines.



Oil Pump

### OIL INLET LINE/OIL PUMP BLEEDING

Fill the oil tank with recommended oil. Place a shop towel around the oil pump. Disconnect the oil inlet line from the oil pump and clip it. Fill the oil pump with oil by squirting clean oil through the joint. (About 3cc) Fill the oil line with oil and connect it to the oil pump.

\*

- Bleed air from the oil inlet line first, then bleed air from the oil outlet line.

### OIL OUTLET LINE BLEEDING

1. Disconnect the oil outlet line and bend it into U shape. Force air out of the tube by filling it with oil.
2. Start the engine and allow it to idle with the oil control lever in the fully open position. Visually check the oil flow.
3. If there is no oil flowing out within 1 minute, bleed air from the oil inlet line and oil pump.

\*

- Never run the engine in a closed area.

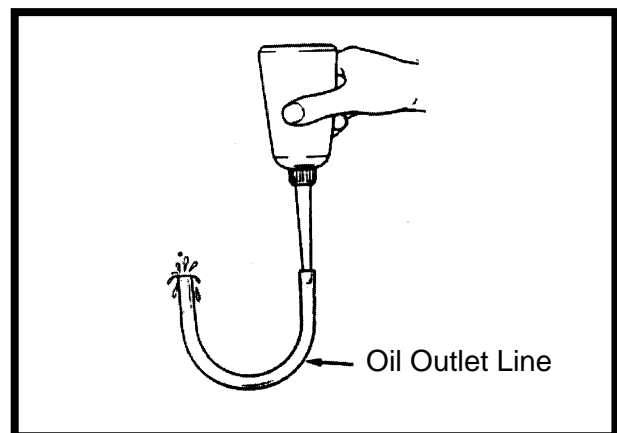

Oil Tube

## OIL TANK

### OIL TANK REMOVAL

- Remove the met-in box.
- Remove the frame body cover.
- Remove the rear carrier.
- Remove the two bolts, four nuts attaching the stay comp fuel tank.
- Remove the oil meter connector.
- Remove the two bolts attaching the oil tank.
- Disconnect the oil inlet line.
- Drain the oil inside the oil tank into a clean container.
- Remove the oil tank.
- The installation sequence is the reverse of removal.

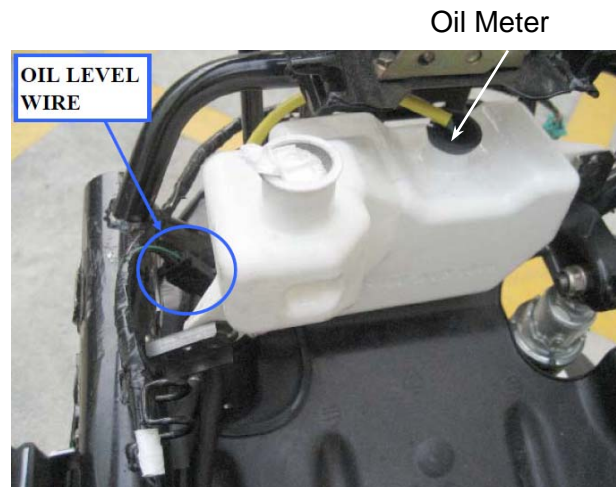

\*

- Connect the oil line properly.
- Bleed air from the oil pump after installation.
- The oil tube clip (at the oil tank side) must be locked from inside of the oil tube joint.

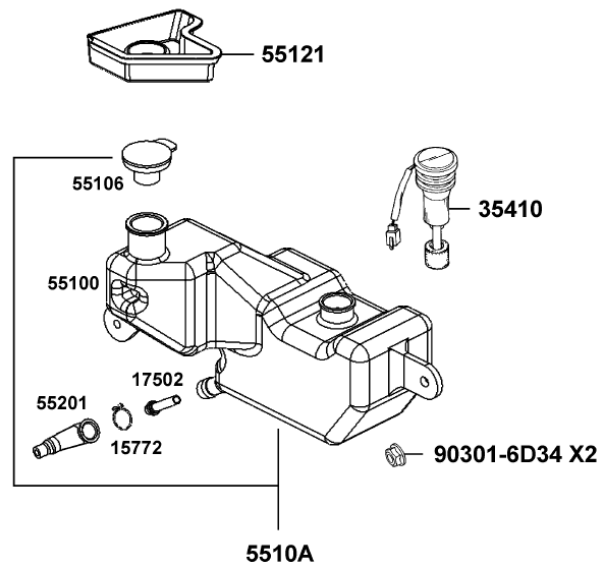

**ENGINE REMOVAL/INSTALLATION**

SERVICE INFORMATION ..... 5-1  
ENGINE REMOVAL..... 5-2  
ENGINE INSTALLATION..... 5-4

## SERVICE INFORMATION

### GENERAL INSTRUCTIONS

- A floor jack or other adjustable support is required to support and maneuver the engine. Be careful not to damage the motorcycle body, cables and wires during engine removal.
- Use shop towels to protect the motorcycle body during engine removal.
- Parts requiring engine removal for servicing:
  - Crankcase
  - Crankshaft

### TORQUE VALUES

Engine hanger frame side nut	6.0~7.0kg-m
Rear shock absorber lower mount bolt	2.4~3.0kg-m
Engine hanger engine side	3.3~4.3kg-m

## 5. ENGINE REMOVAL/INSTALLATION

G-DINK 50

### ENGINE REMOVAL

Remove the frame body cover.  
Remove the two bolts attaching the air cleaner case.  
Loosen the band between the air cleaner and carburetor to remove the air cleaner case.  
Remove the carburetor cap.

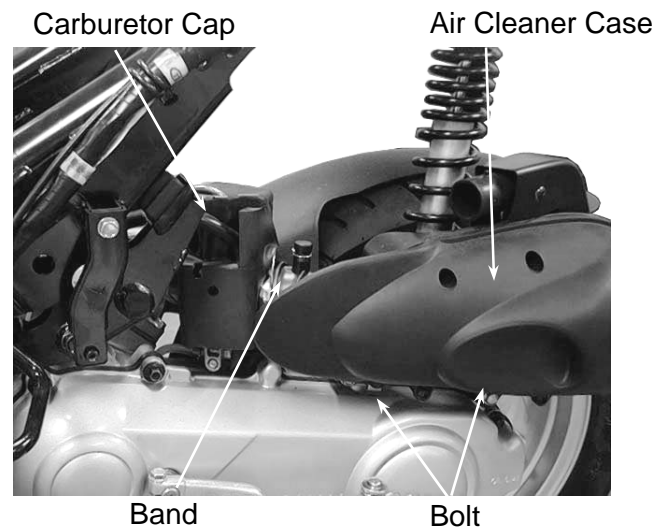

Disconnect the auto bystarter, A.C. generator and starter motor wire connectors.

AC Generator Wire Connector

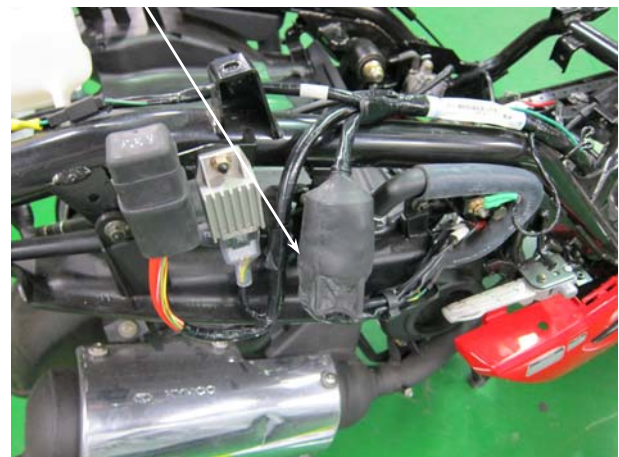

Disconnect the oil pump control cable from the pump body.  
Disconnect the oil inlet line from the oil pump.  
Remove the spark plug cap.

Oil Pump Control Cable



\* After the oil inlet line is disconnected, plug the oil line opening to prevent oil from flowing out.

Remove the rear brake adjusting nut and disconnect the brake cable from the crankcase.

Remove the rear brake cable clamp and rear brake cable.

Remove the cooling air tube band on the left crankcase cover and disconnect the cooling air tube.

Remove the rear shock absorber lower mount bolt.

Rear Shock Absorber Lower Mount Bolt

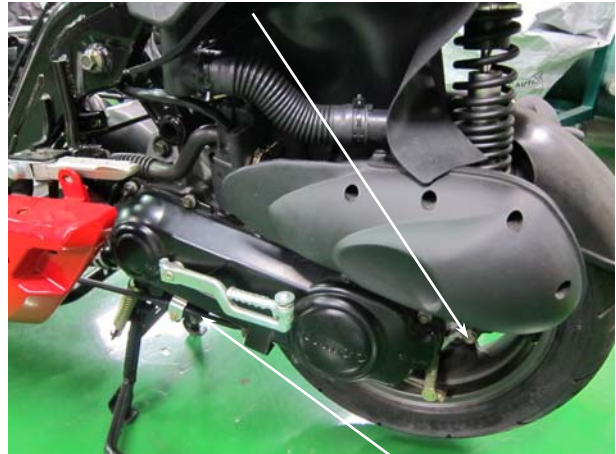

Rear Brake Cable

Remove the right and left engine mounting nuts.

Take out the right and left engine mounting bolts.

Lift the frame upward to separate it from the engine and be careful not to damage the rear fender.

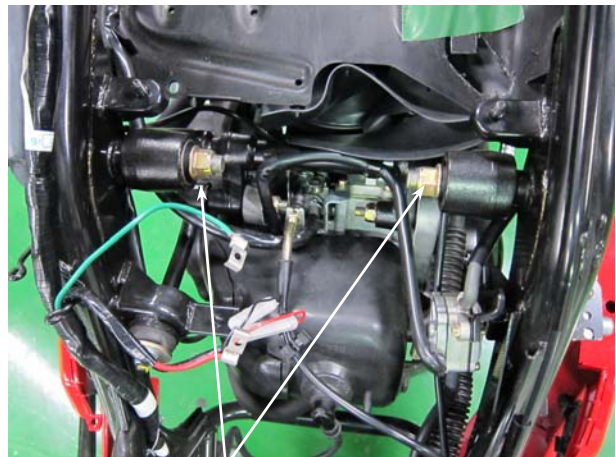

Engine Mounting Nuts

### ENGINE HANGER BRACKET REMOVAL

Remove the engine hanger bracket bolt and engine hanger bracket.

The installation sequence is the reserve of removal.

**Torque:** 3.3~4.3kg-m

Engine Hanger



Engine Hanger Bracket Bolt

### ENGINE HANGER BRACKET INSPECTION

Inspect the stopper rubbers and bushings for damage and replace with new ones if necessary.

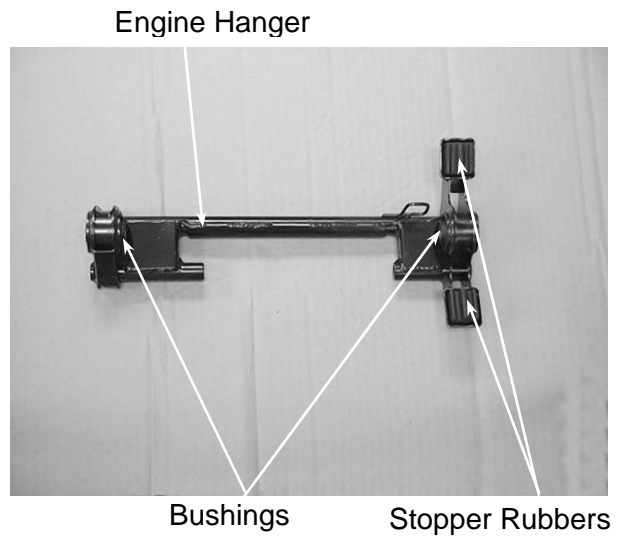

### ENGINE INSTALLATION

Install the engine in the reverse order of removal.

\* Cables and wires should be routed properly.

#### Torque Values:

Engine mounting bolt : 6~7kg-m

Rear shock absorber lower mount bolt:  
: 2.4~3.0kg-m

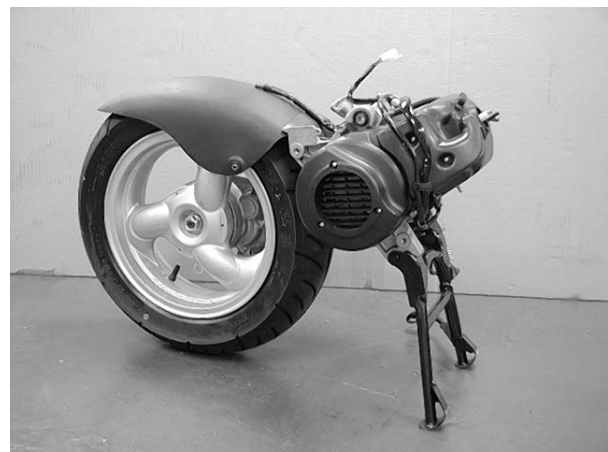

Perform the following inspections and adjustments after installation.

- Throttle cable
- Oil pump control cable
- Rear brake cable
- Oil pump bleeding

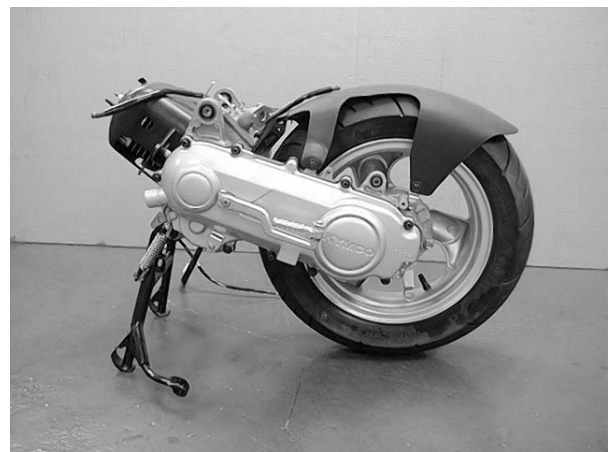

**CYLINDER HEAD/CYLINDER/PISTON**

SERVICE INFORMATION ..... 6-2  
TROUBLESHOOTING ..... 6-2  
CYLINDER HEAD ..... 6-3  
CYLINDER/PISTON ..... 6-6

# 6. CYLINDER HEAD/CYLINDER/PISTON

G-DINK 50

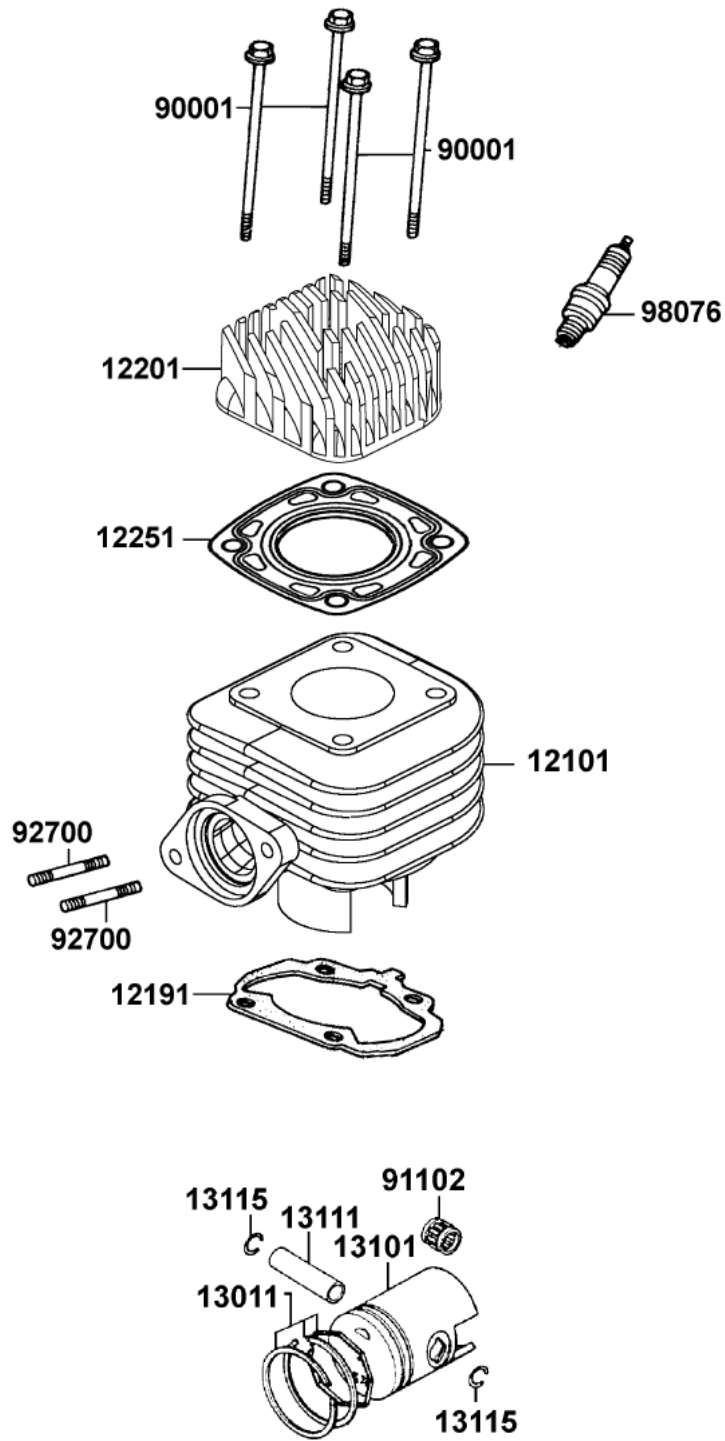

## SERVICE INFORMATION

### GENERAL INSTRUCTIONS

- The cylinder head, cylinder and piston can be serviced with the engine installed in the frame.
- Before disassembly, clean the engine to prevent dust from entering the engine.
- Remove all gasket material from the mating surfaces.
- Do not use a driver to pry between the cylinder and cylinder head, cylinder and crankcase.
- Do not damage the cylinder inside and the piston surface.
- After disassembly, clean the removed parts before inspection. When assembling, apply the specified engine oil to movable parts.

### SPECIFICATIONS

Item	Standard (mm)	Service Limit (mm)
	G-DINK 50	G-DINK 50
Cylinder head warpage	—	0.10
Piston O.D.(5mm from bottom of piston skirt)	38.970~38.955	38.90
Cylinder-to- piston clearance		0.10
Piston pin hole I.D.	12.002~12.008	12.03
Piston pin O.D.	11.994~12.0	11.98
Piston-to-piston pin clearance	←	←
Piston ring end gap (top/second)	0.10~0.25	0.40
Connecting rod small end I.D.	17.005~17.017	17.03
Cylinder bore	39.0~39.025	39.05

### TORQUE VALUES

Cylinder head bolt	1.5~1.7kg-m
Exhaust muffler joint lock nut	1.0~1.4kg-m
Exhaust muffler lock bolt	3.0~3.6kg-m
Spark plug	1.1~1.7kg-m

### ●TROUBLESHOOTING

#### Compression too low, hard starting or poor performance at low speed

- Leaking cylinder head gasket
- Loose spark plug
- Worn, stuck or broken piston and piston rings
- Worn or damaged cylinder and piston

#### Compression too high, overheating or knocking

- Excessive carbon build-up in cylinder head or on piston head

#### Abnormal noisy piston

- Worn cylinder and piston
- Worn piston pin or piston pin hole
- Worn connecting rod small end bearing

#### Abnormal noisy piston rings

- Worn, stuck or broken piston rings
- Worn or damaged cylinder

## CYLINDER HEAD

### REMOVAL

Remove the rear carrier.  
Remove the frame body cover.  
Remove the spark plug cap.

Spark Plug Cap



Remove the three bolts attaching the fan cover to remove the fan cover.  
Remove the two joint lock nuts on the front of the exhaust muffler and then remove the two exhaust muffler lock bolts.  
Remove the bolt attaching the engine hood to remove the engine hood.  
The installation sequence is the reverse of removal.

Fan Cover/Engine Hood

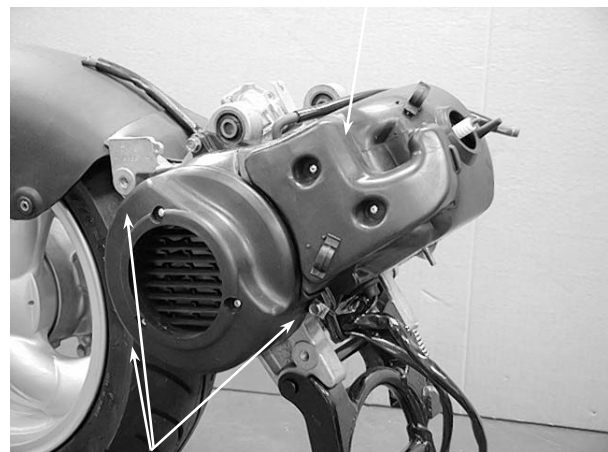

\* When installing the exhaust muffler, first tighten the two nuts on the front and then tighten the two bolts.

Bolts

Remove the spark plug.  
Remove the cylinder head bolts and the cylinder head.

\* Loosen the bolts diagonally in 2 or 3 times.

Cylinder head Bolts

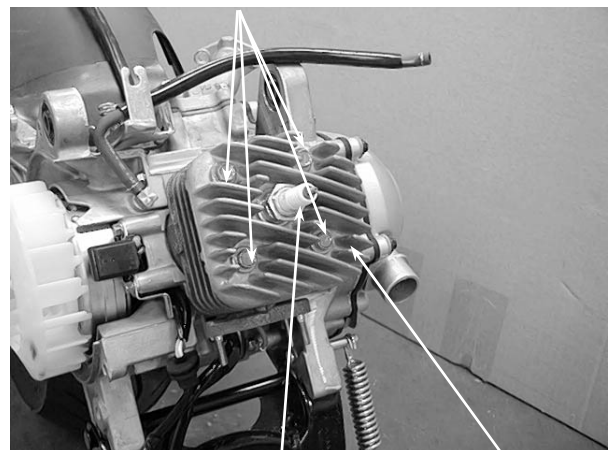

Spark Plug      Cylinder Head

Remove the cylinder head gasket.

## COMBUSTION CHAMBER DECARBONIZING

Remove the carbon deposits from the combustion chamber

\* Avoid damaging the combustion chamber wall and cylinder mating

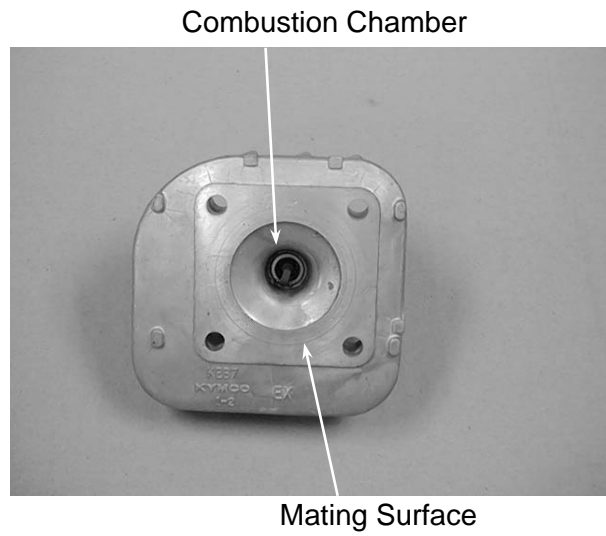

## CYLINDER HEAD INSPECTION

Check the cylinder head for warpage with a straight edge and feeler gauge.

**Service Limit:**

0.10mm replace if over



## CYLINDER HEAD INSTALLATION

Install the cylinder head on the cylinder properly.

\* Be careful not to damage the mating surfaces.

Install a new cylinder head gasket onto the cylinder.

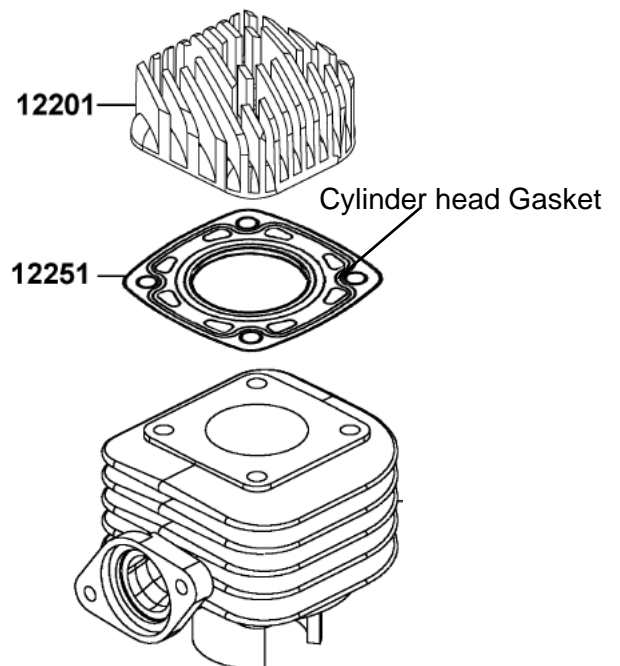

### Cylinder Head Bolts Installation

Install and tighten the cylinder head bolts diagonally in 2 or 3 times.

**Torque:** 1.5~1.7kg-m

Install the spark plug.

**Torque:** 1.1~1.7kg-m

Cylinder head Bolts

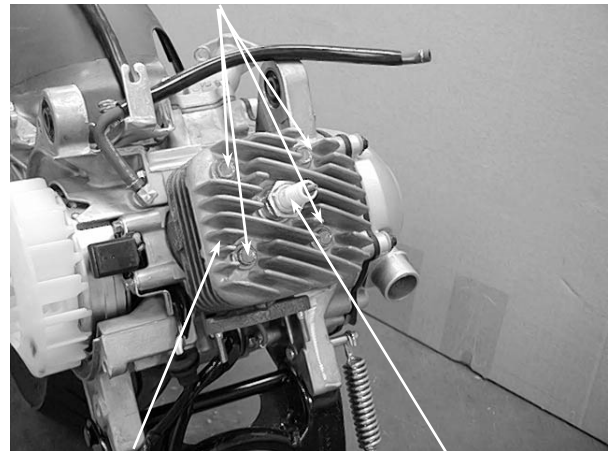

Cylinder Head

Spark Plug

### Engine Hood Installation

Install the engine hood.

Install the spark plug cap.

Spark Plug

Engine Hood

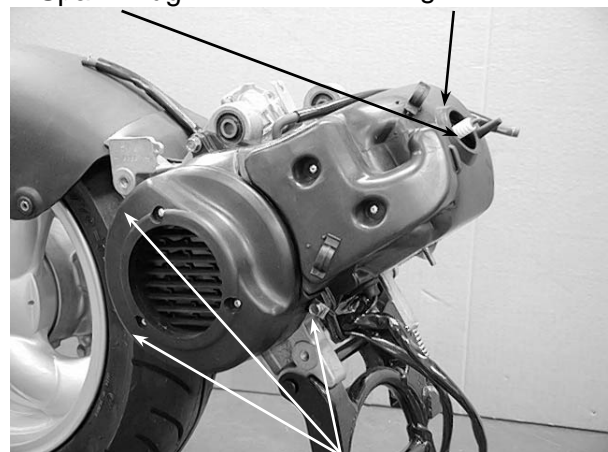

Bolt

Perform the following inspections after installation:

- Compression test
- Abnormal engine noise
- Cylinder air leaks



### CYLINDER/PISTON

#### CYLINDER REMOVAL

Remove the met-in box and seat.  
Remove the frame body cover.  
Remove the cylinder head.  
Remove the two exhaust muffler joint lock nuts and two exhaust muffler lock bolts.  
Remove the exhaust muffler.  
Remove the cylinder.  
Remove the cylinder gasket.

- \* Do not pry between the cylinder and crankcase or strike the fins.

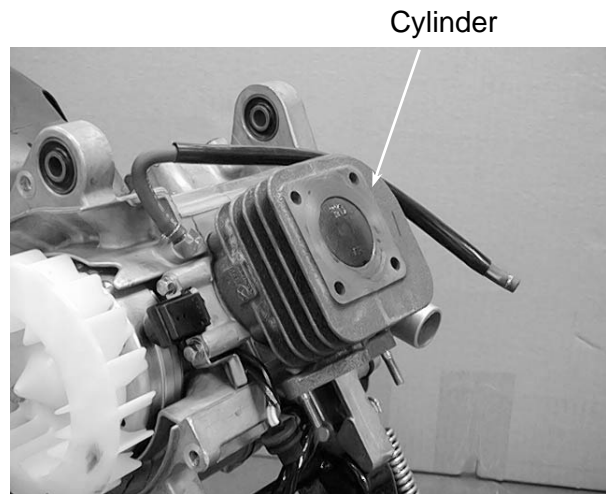

#### PISTON REMOVAL

Remove the piston pin clip to remove the piston pin and piston.

- \*
- Do not damage or scratch the piston.
  - Do not apply side force to the connecting rod when removing the piston pin.
  - Place clean shop towels in the crankcase to keep the piston pin clip from falling into the crankcase.

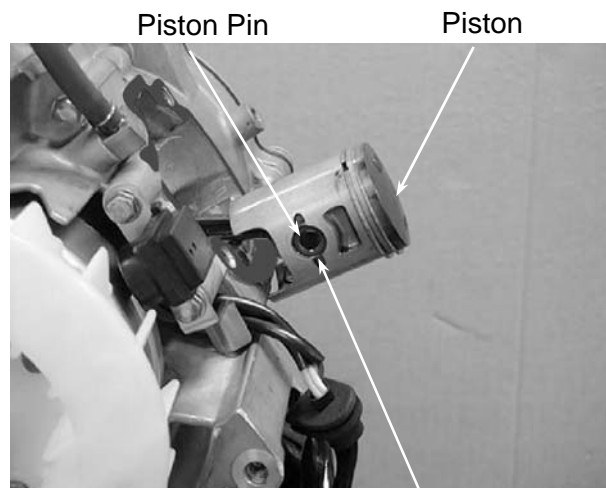

Piston Pin Clip

Spread each piston ring and remove by lifting it up at a point just opposite the gap.  
Remove the expander.



## CYLINDER/PISTON INSPECTION

Check the cylinder and piston for wear or damage.

Clean carbon deposits from the exhaust port area.

\*

Be careful not to damage the cylinder inside wall.



Measure the cylinder bore at three levels of A, B and C in both X and Y directions. Avoid the port area. Take the maximum figure measured to determine the cylinder bore.

**Service Limit:**

39.05mm replace if over

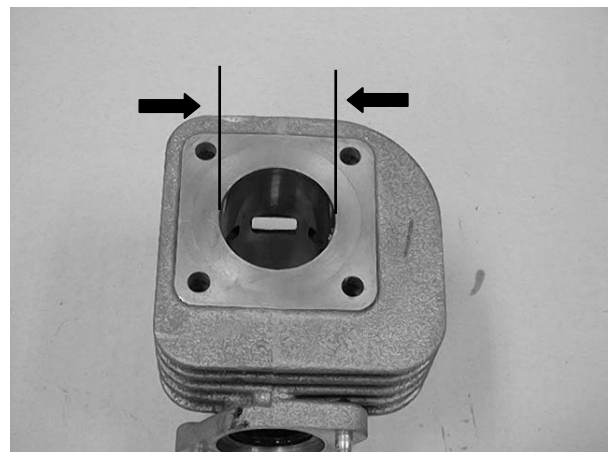

Inspect the top of the cylinder for warpage.

**Service Limit:**

0.10mm replace if over



\* The cylinder has an 'A' mark or no mark on it. When replacing the cylinder with a new one, use a cylinder having the same mark as the old one.



Measure the piston O.D. at a point 5mm from the bottom of the piston skirt.

**Service Limit:**

38.90mm replace if below

Measure the piston-to-cylinder clearance.

**Service Limit:**

0.10mm replace if over

Measure the piston pin hole I.D.

**Service Limit:**

12.03mm replace if over

Measure the piston pin O.D.

**Service Limit:**

11.98mm replace if below

Measure the piston-to-piston pin clearance.

**Service Limit:**

0.03mm replace if over

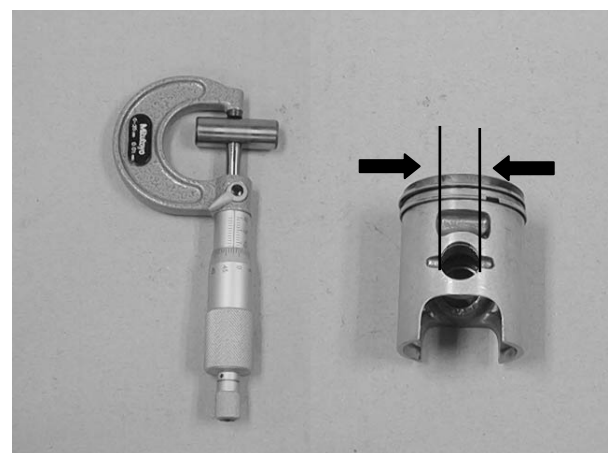

### PISTON RING INSPECTION

Measure each piston ring end gap.

**Service Limits:** Top/Second  
0.40mm replace if over

\* Set each piston ring squarely into the cylinder using the piston and measure the end gap.

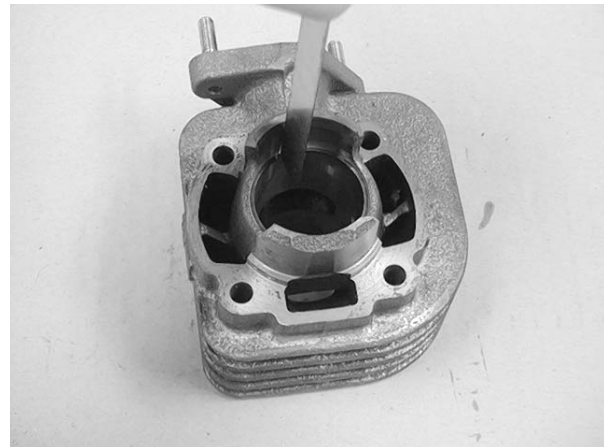

### CONNECTING ROD SMALL END INSPECTION

Install the piston pin and bearing in the connecting rod small end and check for excessive play.

Measure the connecting rod small end I.D.

**Service Limit:**  
17.03mm replace if over

<Small End I.D. Measurement>

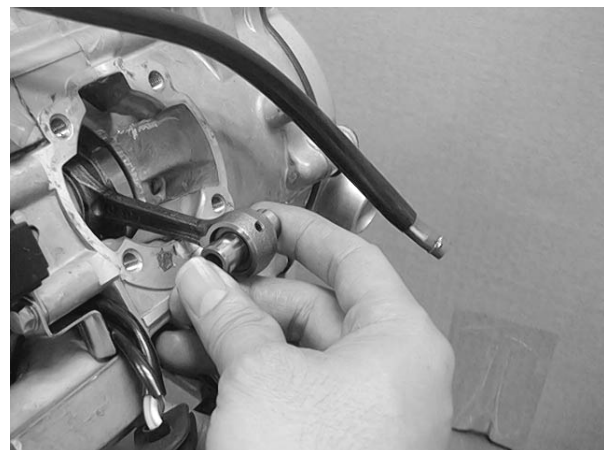

### PISTON/CYLINDER INSTALLATION

First install the expander in the second ring groove.

Then install the top and second rings in their respective ring grooves.

The piston rings should be pressed into the grooves with even force.

After installation, check and make sure that each ring is flush with the piston at several points around the ring.

A ring that will not compress means that the ring groove has carbon deposits in it and should be cleaned.

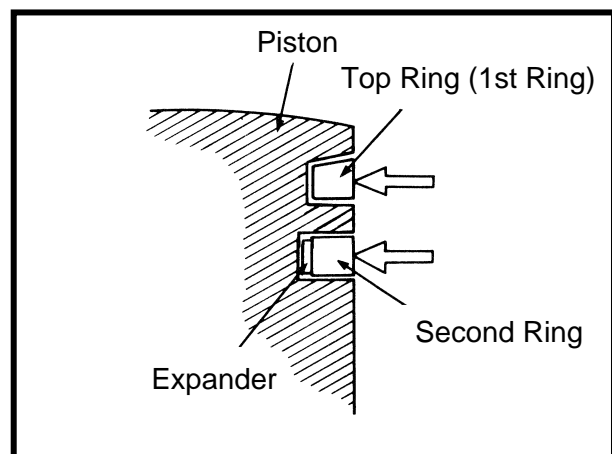

Install a new cylinder gasket on the mating surface between the cylinder and crankcase.

Cylinder Gasket

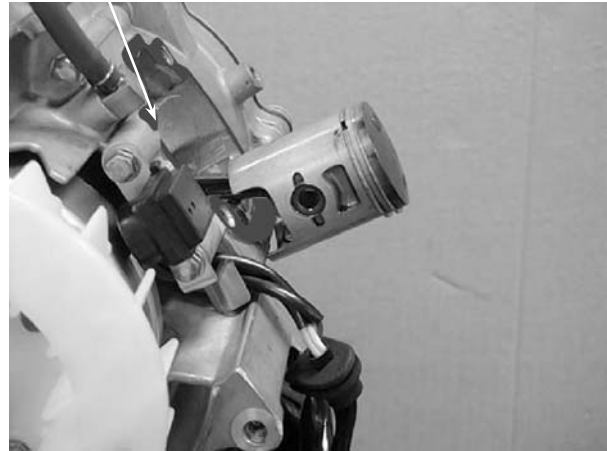

Make sure that the ring end gaps are aligned with the piston ring pins in the ring grooves.

Lubricate the cylinder inside and piston rings with engine oil and install the piston into the cylinder while compressing the piston rings.

Ring Pins

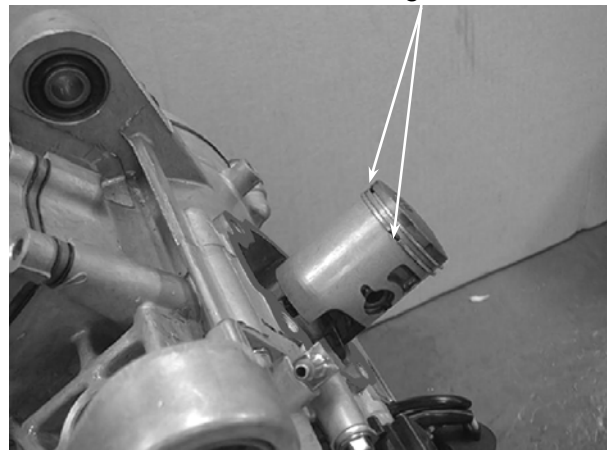

\* Be careful not to damage the piston.

Install the cylinder head.

**Torque:** 1.5~1.7kg-m

Install the exhaust muffler and tighten the exhaust muffler joint lock nuts.

**Torque:** 1.0~1.4kg-m

Tighten the exhaust muffler lock bolts.

**Torque:** 3.0~3.6kg-m

Install the frame covers.

Install the met-in box.

The installation sequence is the reverse of removal .

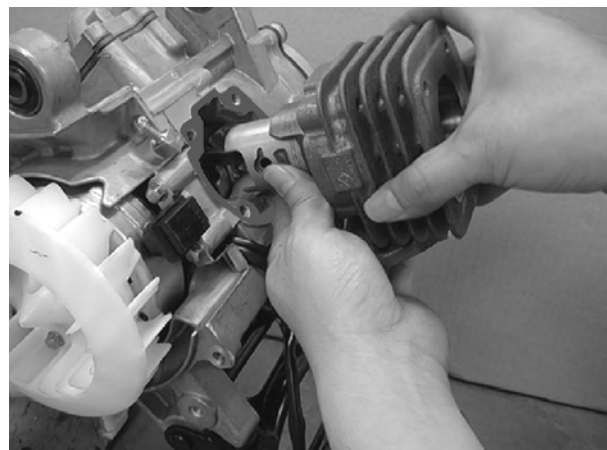

---

---

---

---

---

---

---

---

**A.C. GENERATOR**



SERVICE INFORMATION ..... 7-2  
A.C. GENERATOR REMOVAL..... 7-3  
A.C. GENERATOR INSTALLATION..... 7-4

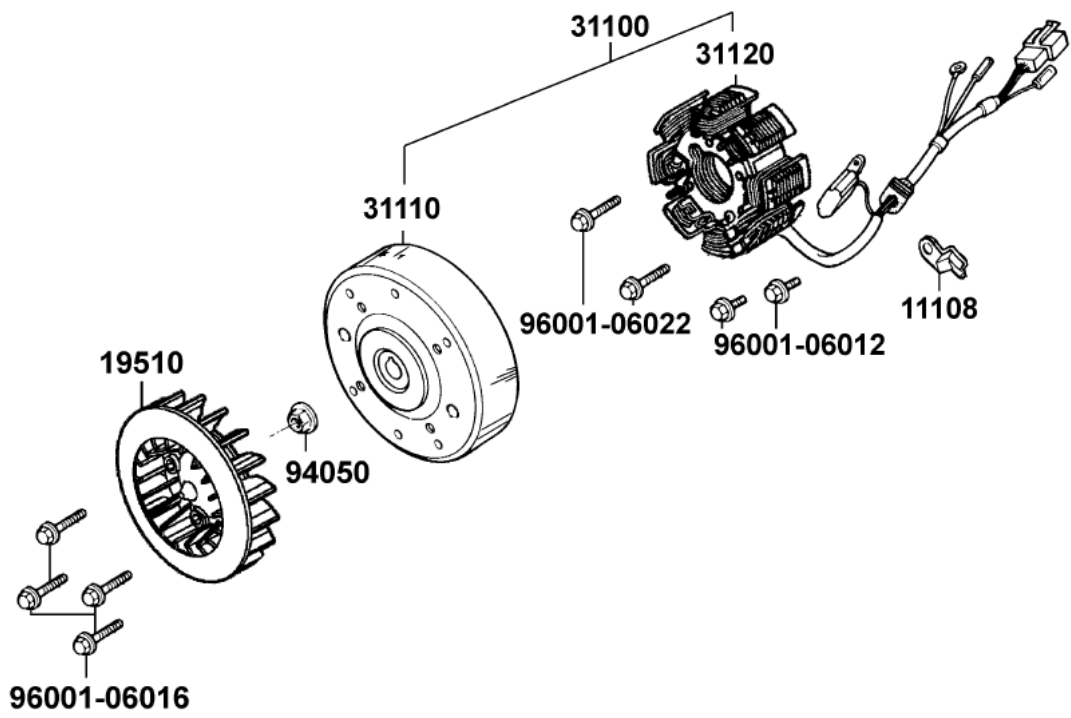

## SERVICE INFORMATION

### GENERAL INSTRUCTIONS

- All A.C. generator maintenance and inspection can be made with the engine installed.
- Refer to Section 15 for A.C. generator inspection.

### TORQUE VALUE

Flywheel nut : 3.5~4.0kg-m

### SPECIAL TOOLS

Flywheel puller  
Universal holder

## A.C. GENERATOR REMOVAL

Remove the three bolts attaching the fan cover to remove the fan cover.

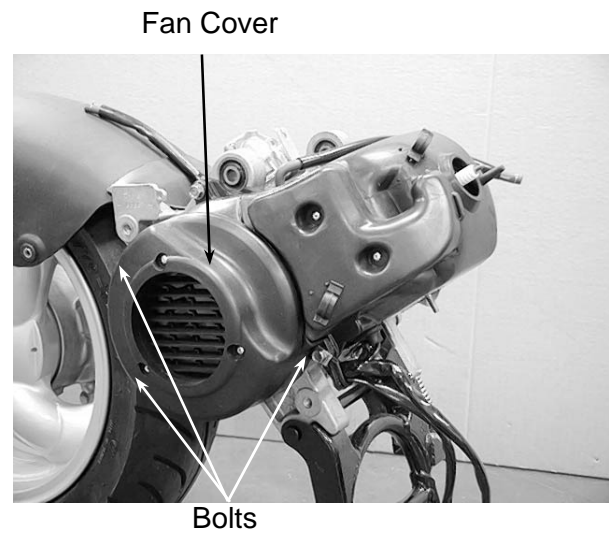

Remove the cooling fan by removing the four bolts.

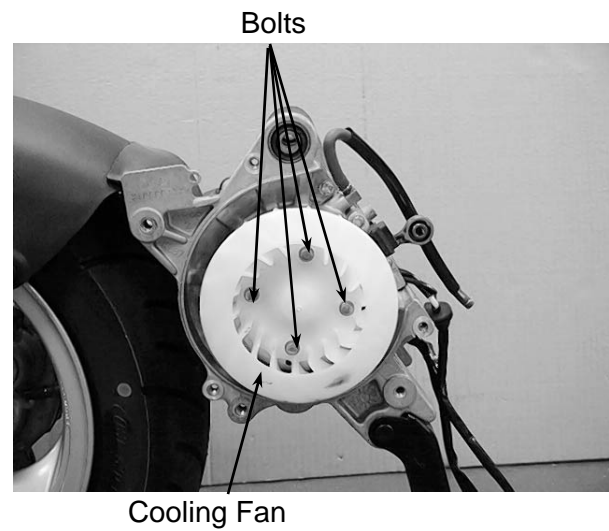

Hold the flywheel with an universal holder and then remove the 10mm flywheel nut.

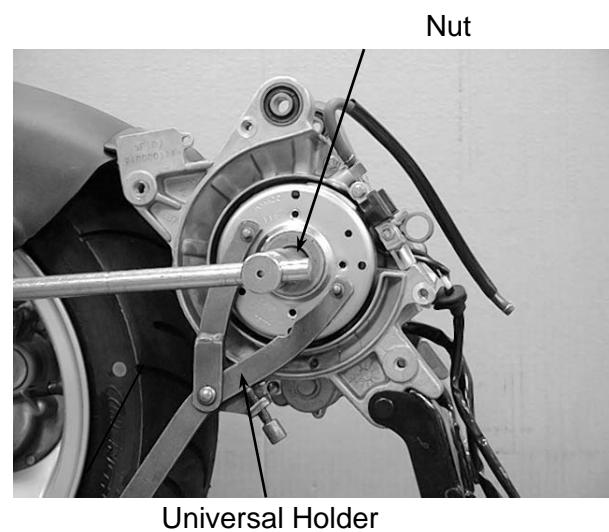

Remove the A.C. generator flywheel using the flywheel puller.

Lock Nut Wrench

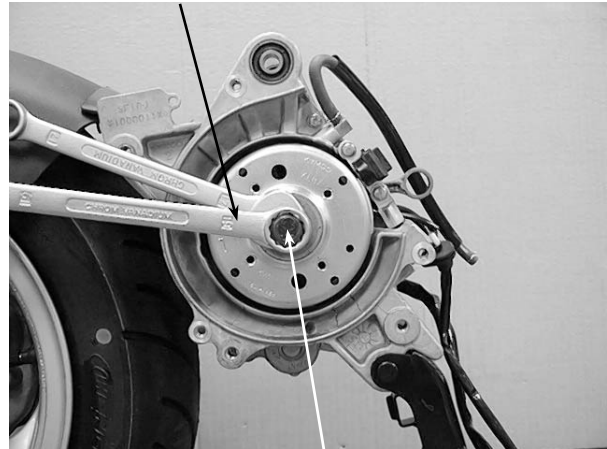

Flywheel Puller

Remove the A.C. generator wire connector.

A.C. Generator Wire Connector

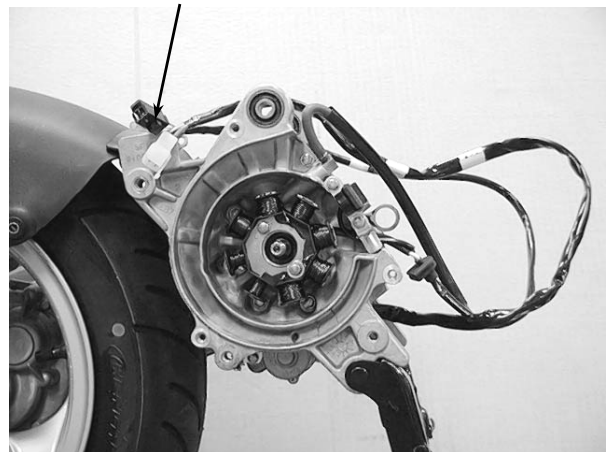

Remove the two pulser coil bolts and pulser coil from the right crankcase.  
Remove the pulser coil wire clamp from the right crankcase.  
Remove the two bolts attaching the A.C. generator stator.

\* Be careful not to damage the disconnected wire.

### A.C. GENERATOR INSTALLATION

Install the A.C. generator stator and pulser coil wire clamp onto the right crankcase, and then install the pulser coil.

Stator

Pulser Coil

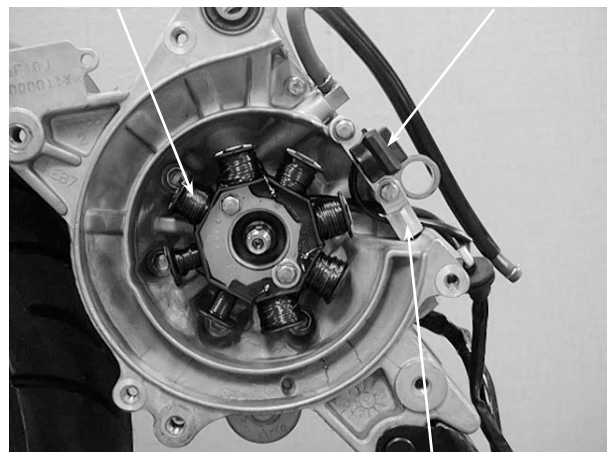

Wire Clamp

Install the A.C. generator and pulser coil bolts.  
Connect the A.C. generator wire connector.

A.C. Generator Wire

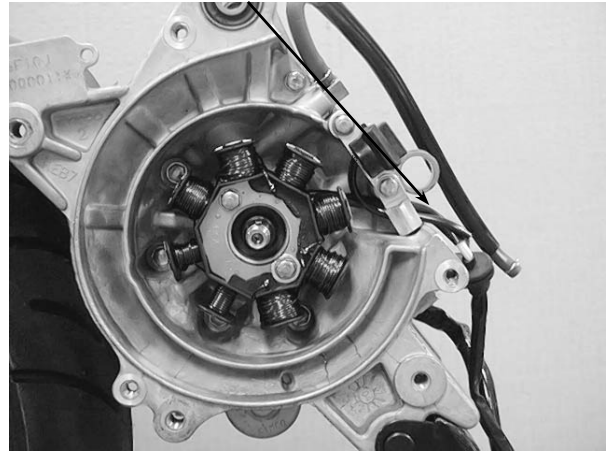

Clean the taper hole in the flywheel off any burrs and dirt.  
Install the woodruff key in the crankshaft keyway.

Woodruff Key

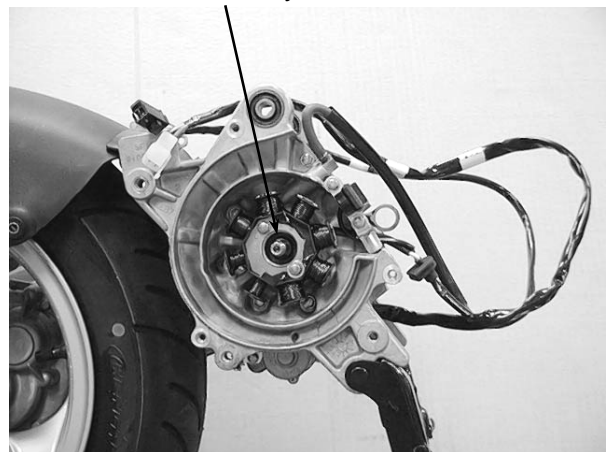

Install the flywheel onto the crankshaft with the flywheel groove aligned with the crankshaft woodruff key.  
Hold the flywheel with the universal holder and install the 10mm flywheel flange nut.

**Torque:** 3.5~4.0kg-m

Start the engine and check the ignition timing.

Install other removed parts in the reserve order of removal.

Universal Holder

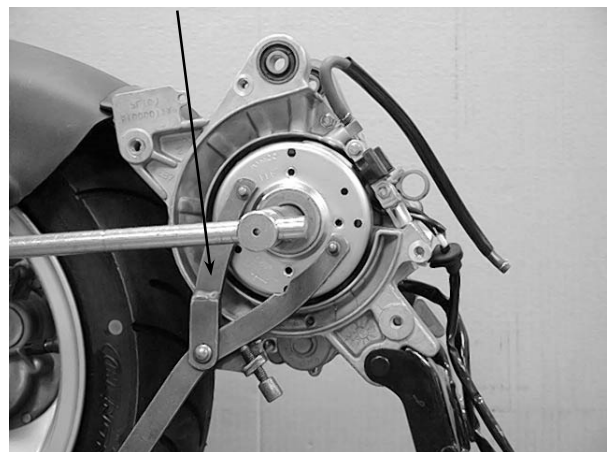

---

---

---

---

---

---

---

---

**KICK STARTER/DRIVE PULLEY/  
CLUTCH/DRIVEN PULLEY**



SERVICE INFORMATION .....	8- 3
TROUBLESHOOTING .....	8- 3
KICK STARTER .....	8- 4
DRIVE BELT .....	8- 8
DRIVE PULLEY .....	8-10
STARTER ONE-WAY CLUTCH DRIVE GEAR .....	8-12
CLUTCH/DRIVEN PULLEY .....	8-15

# 8. KICK STARTER/DRIVE PULLEY/ CLUTCH/DRIVEN PULLEY

G-DINK 50

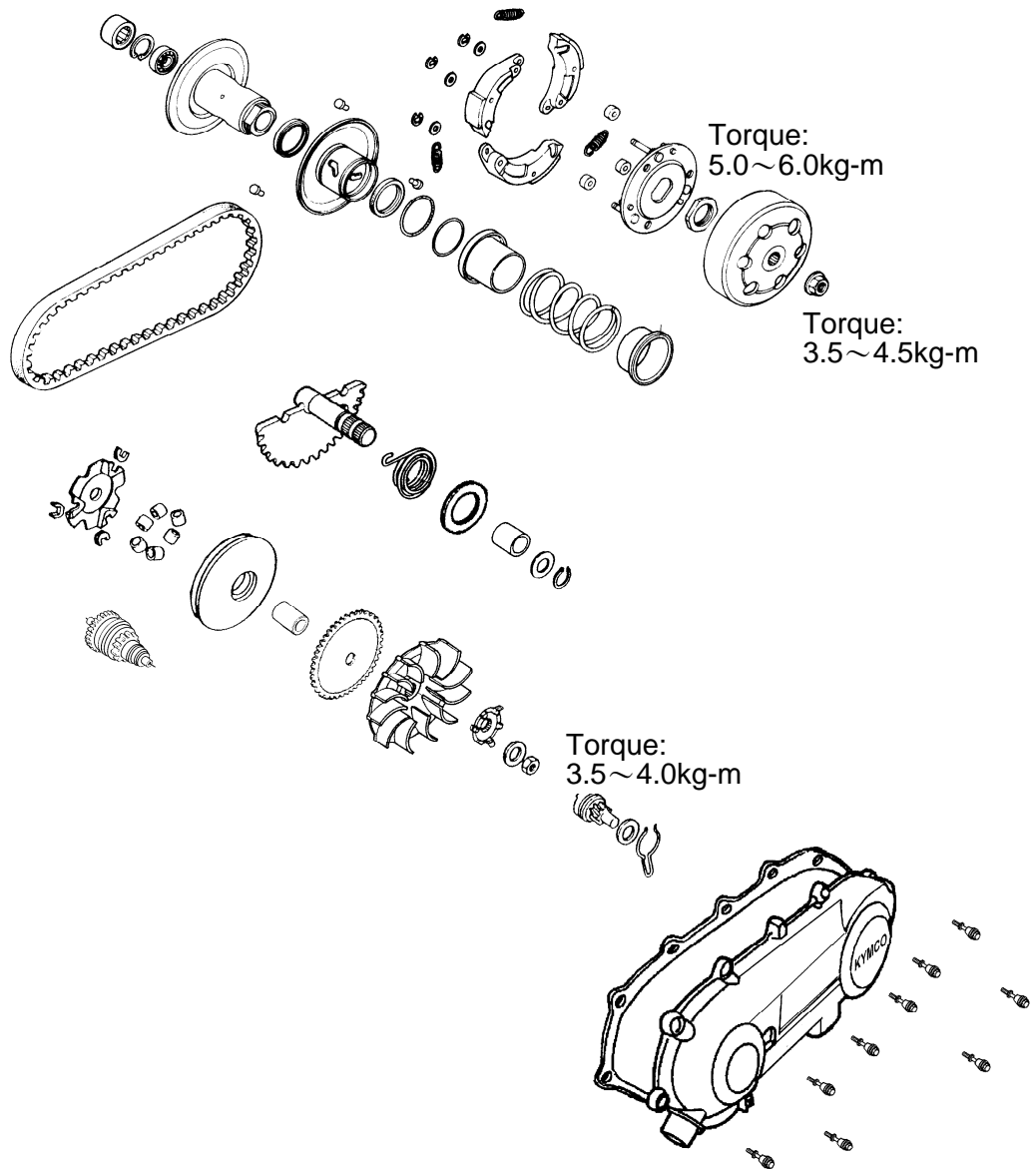

# 8. KICK STARTER/DRIVE PULLEY/ CLUTCH/DRIVEN PULLEY

G-DINK 50

## SERVICE INFORMATION

### GENERAL INSTRUCTIONS

- Avoid getting grease and oil on the drive belt and pulley faces.

SPECIFICATIONS	G-DINK 50	
	Standard (mm)	Service Limit (mm)
Drive pulley collar O.D.	20.01~20.025	24.24
Movable drive face I.D.	20.035~20.085	19.97
Weight roller O.D.	13.0	12.4
Clutch outer I.D.	107~107.2	107.5
Driven face spring free length	87.9	82.6
Driven face O.D.	33.965~33.985	33.94
Movable driven face I.D.	34.0~34.25	34.06
Drive belt width	18	17

### TORQUE VALUES

Drive face nut	3.5~4.0kg-m
Clutch outer nut	3.5~4.5kg-m
Clutch drive plate nut	5.0~6.0kg-m

### SPECIAL TOOLS

Lock nut wrench, 39mm	Universal holder
Clutch spring compressor	Lock nut socket wrench, 32mm
Bearing outer driver 37x40mm	Bearing driver pilot, 17mm
One-way clutch puller	Outer driver, 24x26mm

### TROUBLESHOOTING

#### Engine starts but motorcycle won't move

- Worn drive belt
- Broken ramp plate
- Worn or damaged clutch lining

#### Engine stalls or motorcycle creeps

- Broken clutch weight spring

#### Poor performance at high speed or lack of power

- Worn drive belt
- Weak driven face spring
- Worn weight roller
- Faulty driven face

## 8. KICK STARTER/DRIVE PULLEY/ CLUTCH/DRIVEN PULLEY

G-DINK 50

### KICK STARTER

#### LEFT CRANKCASE COVER REMOVAL

Remove the drive belt cooling air tube connector circlip.  
Remove the nine left crankcase cover bolts, left crankcase cover and dowel pins.  
Inspect the left crankcase cover seal rubber for damage or deterioration.

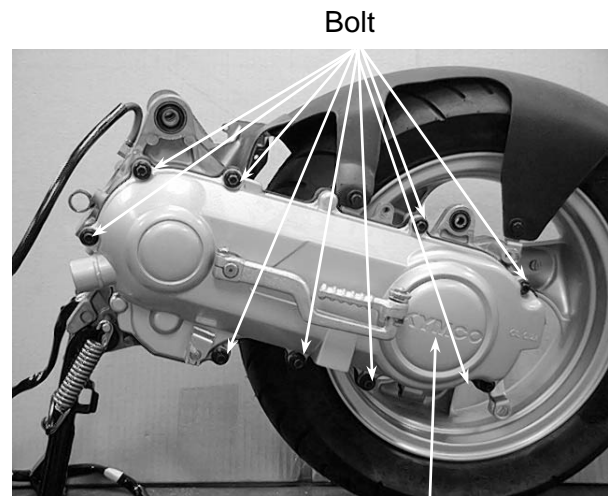

Left Crankcase Cover

#### KICK STARTER SPINDLE REMOVAL

Remove the kick lever from the kick starter spindle.  
Remove the circlip and washer from the kick starter spindle.

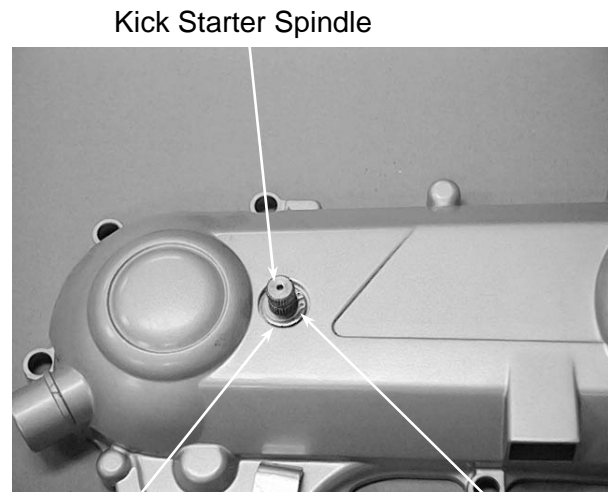

Washer

Circlip

Slightly rotate the kick starter spindle to remove the kick starter driven gear together with the friction spring.

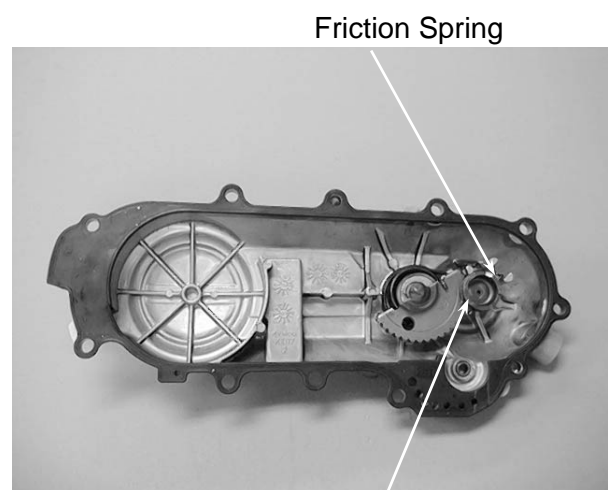

Friction Spring

Kick Starter Driven Gear

## 8. KICK STARTER/DRIVE PULLEY/ CLUTCH/DRIVEN PULLEY

G-DINK 50

Remove the kick starter spindle and return spring from the left crankcase cover.  
Remove the kick starter spindle bushing.

Return Spring

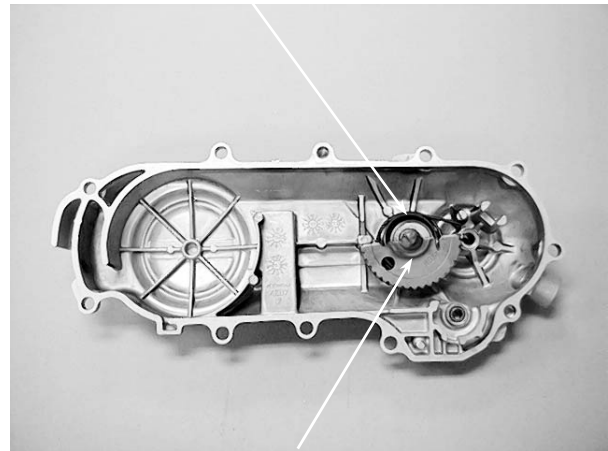

Kick Starter Spindle

### KICK STARTER SPINDLE INSPECTION

Inspect the kick starter spindle and gear for wear or damage.  
Inspect the return spring for weakness or damage.  
Inspect the kick starter spindle bushing for wear or damage.

Spindle

Return Spring

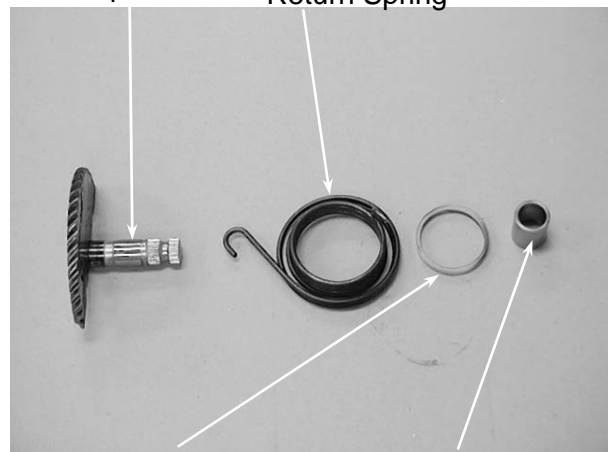

Plastic Bushing

Spindle Bushing

Check the kick starter driven gear for wear or damage.  
Check the friction spring for wear or damage.

Friction Spring

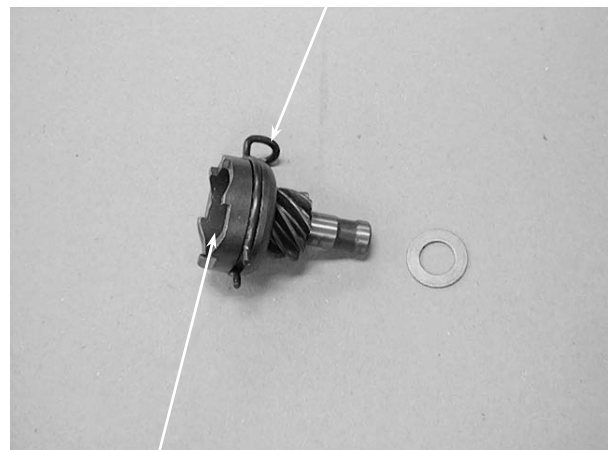

Kick Starter Driven Gear

## 8. KICK STARTER/DRIVE PULLEY/ CLUTCH/DRIVEN PULLEY

G-DINK 50

Inspect the kick starter spindle and driven gear forcing parts for wear or damage.

Kick Starter Spindle Forcing Part

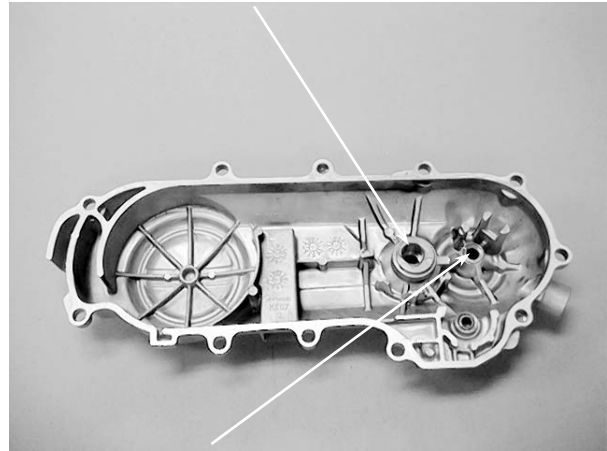

Kick Starter Driven Gear Forcing Part

### KICK STARTER INSTALLATION

Install the kick starter spindle bushing and return spring onto the left crankcase cover.

\* If the hooks of the return spring can not be installed properly, use a screw driver to press them into their locations respectively.

Friction Spring

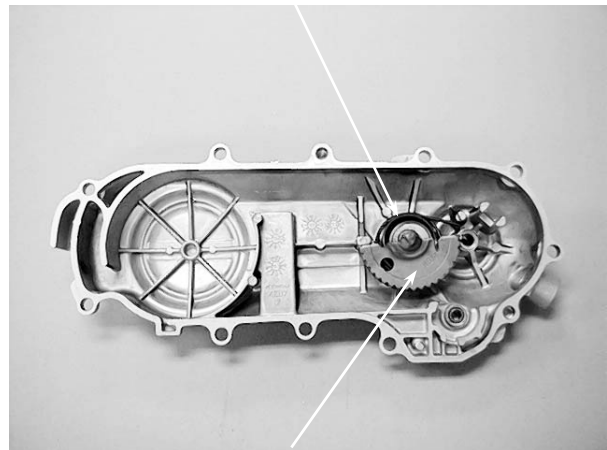

Kick Starter Spindle

Properly install the kick starter driven gear and friction spring as the figure shown.

Friction Spring

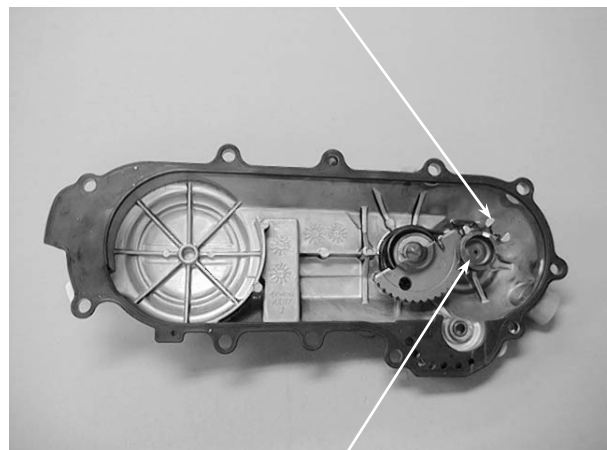

Kick Starter Driven Gear

## 8. KICK STARTER/DRIVE PULLEY/ CLUTCH/DRIVEN PULLEY

G-DINK 50

First install the washer and then the circlip onto the kick starter spindle.  
Install the kick lever.

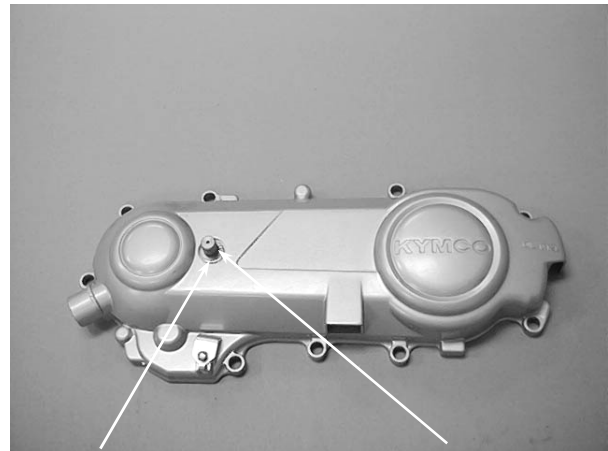

Washer

Circlip

### LEFT CRANKCASE COVER INSTALLATION

First install the dowel pins and then the seal rubber.

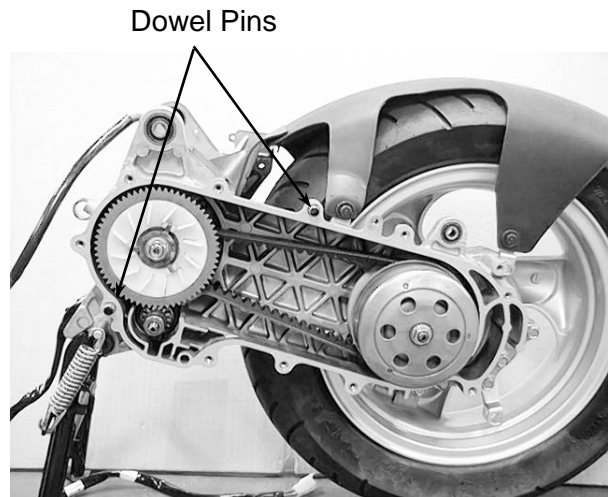

Dowel Pins

Install the left crankcase cover and tighten the ten bolts diagonally.  
Connect the drive belt cooling air tube and install the circlip.

\* For drum brake, note the location of the brake cable clamp and install the rear brake cable in place with the clamp.

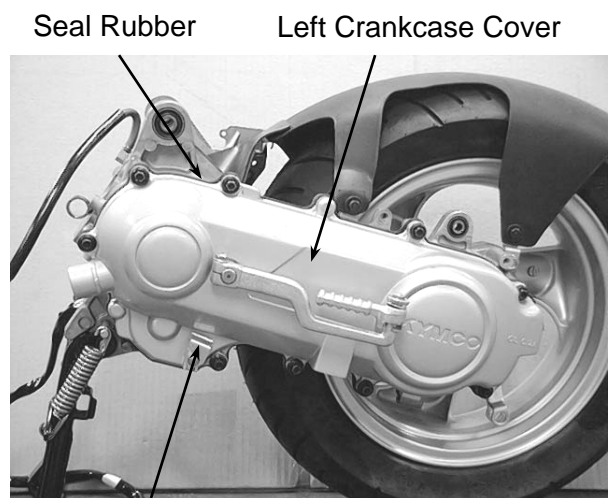

Seal Rubber

Left Crankcase Cover

Rear Brake Cable Clamp

## 8. KICK STARTER/DRIVE PULLEY/ CLUTCH/DRIVEN PULLEY

G-DINK 50

### DRIVE BELT

Remove the left crankcase cover.

### INSPECTION

Check the drive belt for cracks, separation or abnormal or excessive wear.  
Measure the drive belt width.

#### Service Limit:

16.5mm replace if below

\*

Use specified genuine parts for replacement.

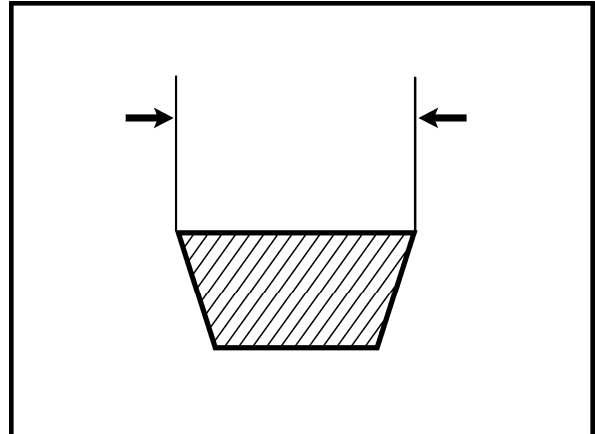

### REPLACEMENT

Remove the ten left crankcase cover bolts and left crankcase cover.  
Hold the clutch outer with the universal holder and remove the 10mm clutch outer nut and clutch outer.

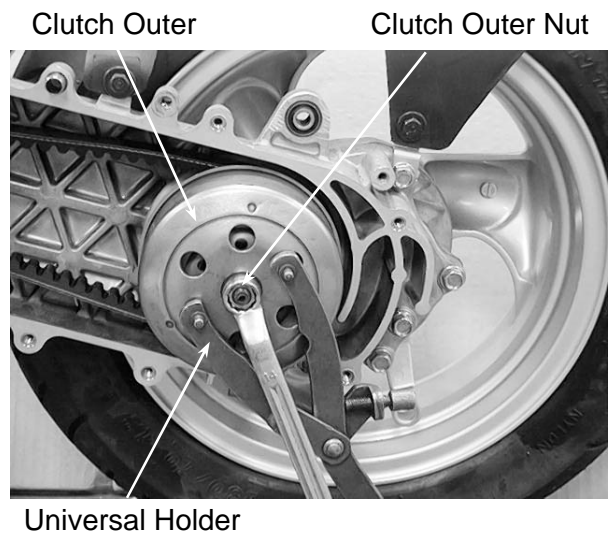

Hold the drive pulley with the holder and remove the 12mm drive face nut.  
Remove the starting ratchet.  
Remove the drive pulley face.

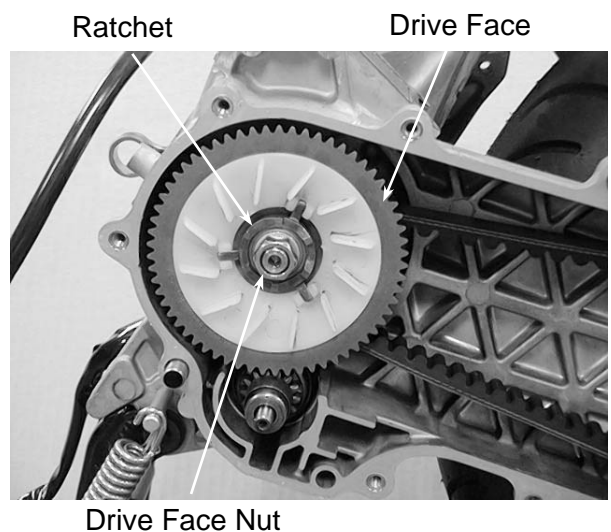

## 8. KICK STARTER/DRIVE PULLEY/ CLUTCH/DRIVEN PULLEY

G-DINK 50

Remove the drive belt from the clutch/  
driven pulley.

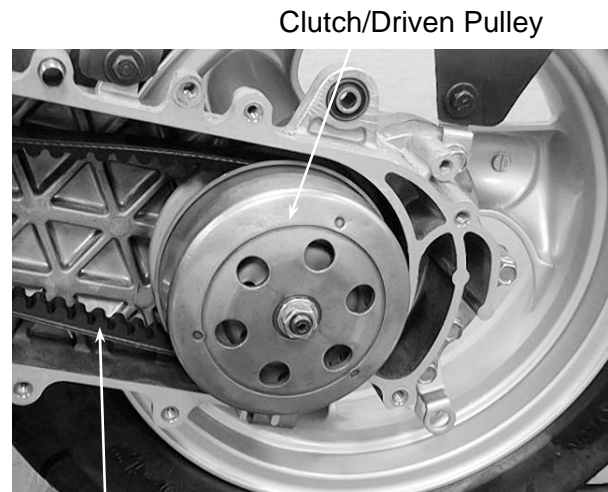

Drive Belt

### DRIVE BELT INSTALLATION

Turn the driven pulley clockwise and lift it  
up to expand the drive belt groove and then  
install a new drive belt.

Drive Belt



Set the drive belt on the drive pulley.  
Install the drive pulley face, starting ratchet  
and 12mm washer, then tighten the drive  
face nut.

**Torque:** 3.5~4.0kg-m

\* When installing the drive face nut, make  
sure that the tooth spaces of the drive  
pulley face and starting ratchet align  
with the teeth of the crankshaft.

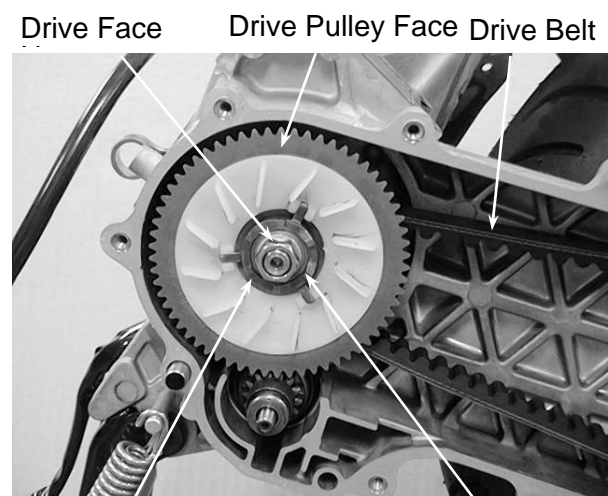

Starting Ratchet

12mm Washer

## 8. KICK STARTER/DRIVE PULLEY/ CLUTCH/DRIVEN PULLEY

G-DINK 50

### DRIVE PULLEY

#### REMOVAL

Hold the drive pulley with the holder and remove the 12mm drive face nut. Remove the starting ratchet, 12mm washer and drive pulley face.

Drive Pulley Face

Starting Ratchet



Face Holder

12mm Drive Face Nut

#### MOVABLE DRIVE FACE DISASSEMBLY

Remove the movable drive face and drive pulley collar from the crankshaft.

Drive Pulley Collar

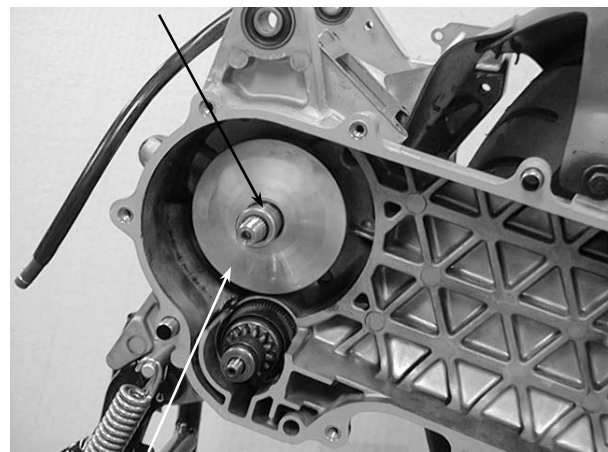

Movable Drive Face

Remove the ramp plate.

Ramp Plate



## 8. KICK STARTER/DRIVE PULLEY/ CLUTCH/DRIVEN PULLEY

G-DINK 50

### MOVABLE DRIVE FACE INSPECTION

Remove the weight rollers.

Check each weight roller for wear or damage.

Measure each roller O.D.

**Service Limit:**

12.4mm replace if below

Weight Roller

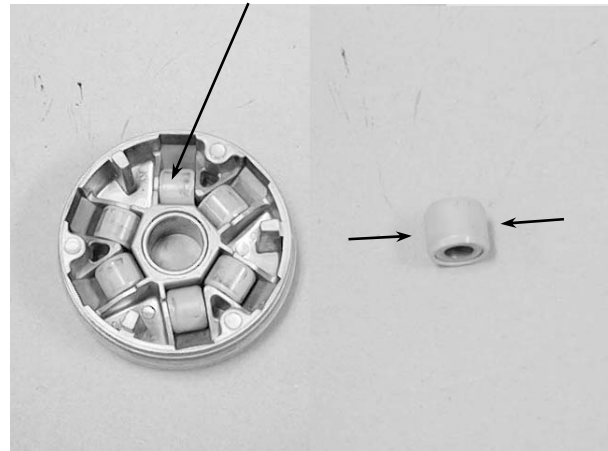

Measure the movable drive face bushing assembly I.D.

**Service Limit:**

20.3mm replace if over

Check the drive pulley collar for wear or damage.

Measure the O.D. of the drive pulley collar sliding surface.

**Service Limit:**

19.9mm replace if below

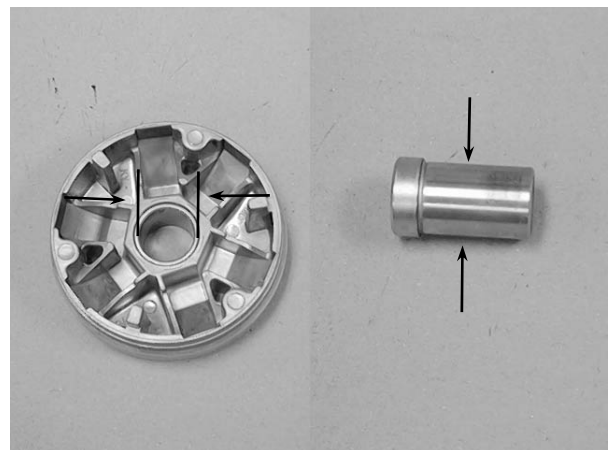

### DRIVE PULLEY INSTALLATION

Install the drive pulley collar and movable drive face onto the crankshaft.

Movable Drive Face

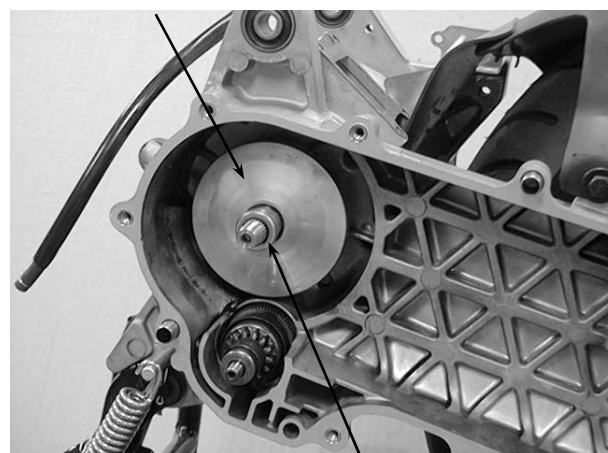

Drive Pulley Collar

## 8. KICK STARTER/DRIVE PULLEY/ CLUTCH/DRIVEN PULLEY

G-DINK 50

Install the drive belt on the crankshaft.  
Install the drive face, starting ratchet and  
washer, then tighten the 12mm drive face  
nut.

**Torque:** 3.5~4.0kg-m

\* Keep grease or oil off the drive belt and  
drive pulley faces.

Drive Pulley Face

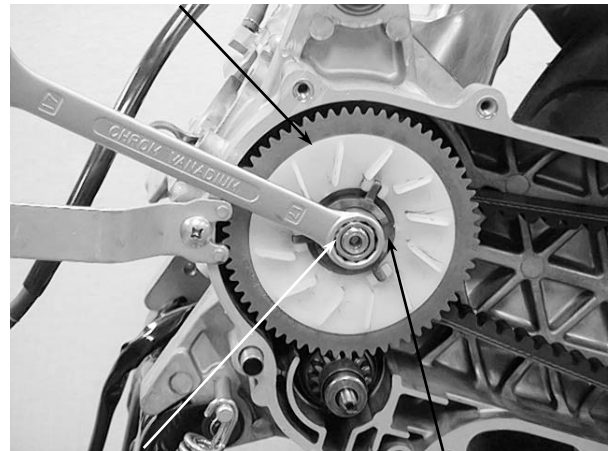

Drive Face Nut

Starting Ratchet

### STARTER PINION REMOVAL

Remove the left crankcase cover.  
Remove the drive pulley.  
Remove the starter pinion.

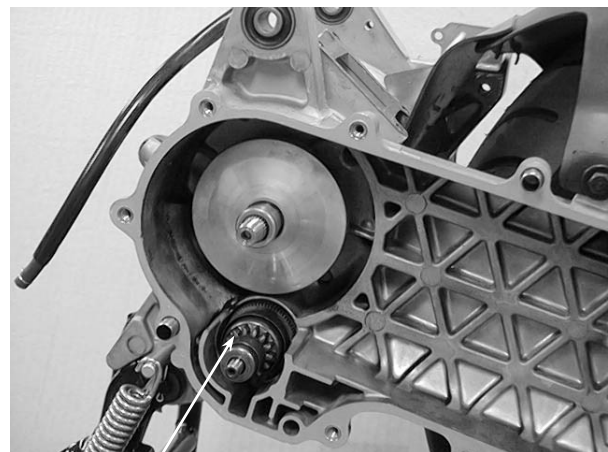

Starter Pinion

### INSPECTION

Inspect the starter pinion seat for wear.  
Inspect the starter pinion for smooth  
operation.  
Inspect the starter pinion shaft forcing parts  
for wear and damage.

### INSTALLATION

Apply a small amount of grease to the  
starter pinion teeth.  
Install the starter pinion in the reverse order  
of removal.

Shaft Forcing Parts

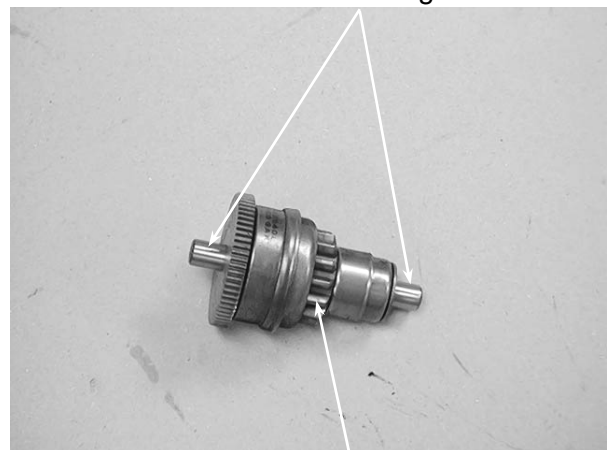

Starter Pinion

## 8. KICK STARTER/DRIVE PULLEY/ CLUTCH/DRIVEN PULLEY

G-DINK 50

### CLUTCH/DRIVEN PULLEY

#### CLUTCH/DRIVEN PULLEY REMOVAL

Remove the drive pulley.  
Hold the clutch outer with the universal holder and remove the 10mm clutch outer nut.  
Remove the clutch outer.

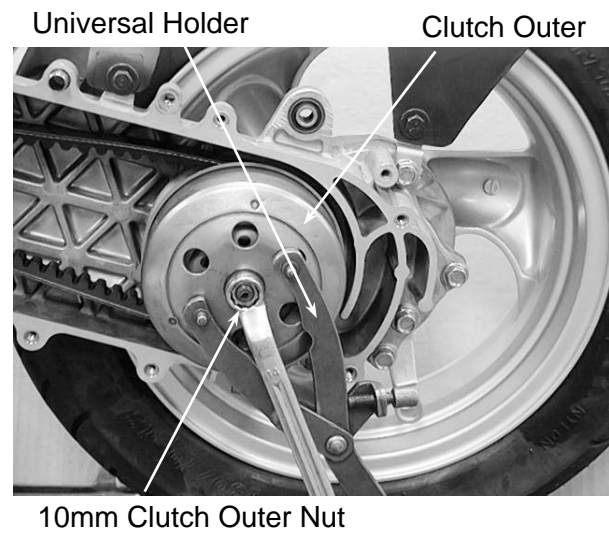

Remove the clutch/driven pulley.  
Remove the drive belt from the clutch/driven pulley.

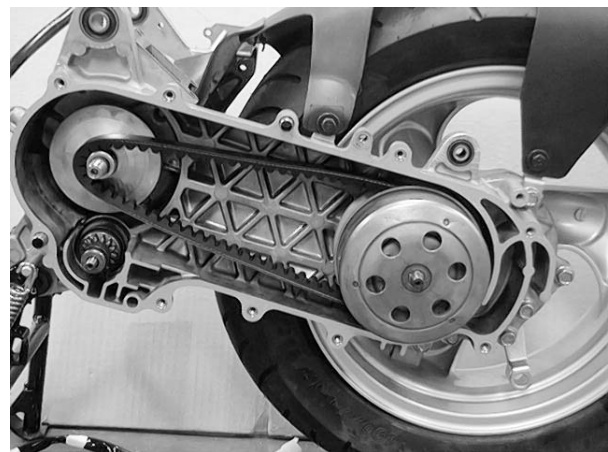

### CLUTCH/DRIVEN PULLEY DIS-ASSEMBLY

Compress the clutch/driven pulley spring with the clutch spring compressor and remove the 28mm drive plate nut.  
Remove the driven face spring.

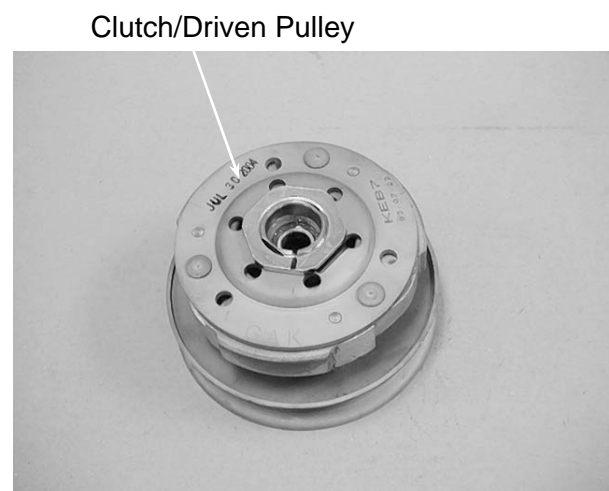

## 8. KICK STARTER/DRIVE PULLEY/ CLUTCH/DRIVEN PULLEY

G-DINK 50

Remove the seal collar.



Seal Collar

Pull out the guide roller pins from the driven pulley and then remove the O-rings and oil seal from the driven pulley.

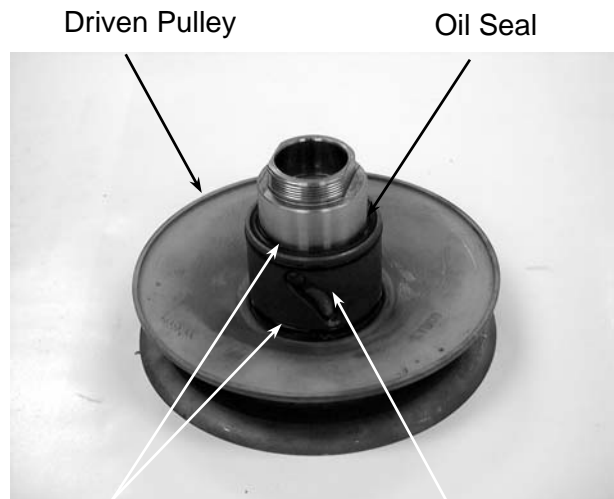

O-rings

Guide Roller Pin

### CLUTCH/DRIVEN PULLEY INSPECTION

Inspect the clutch outer for wear or damage.

Measure the clutch outer I.D.

**Service Limit:**

107.5mm replace if below

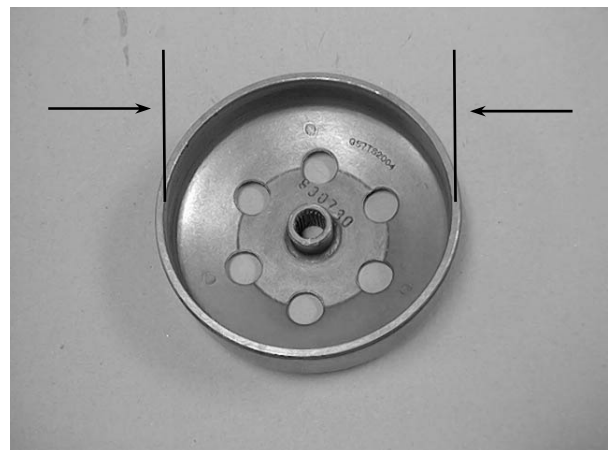

## 8. KICK STARTER/DRIVE PULLEY/ CLUTCH/DRIVEN PULLEY

G-DINK 50

Check the clutch shoes for wear or damage.  
Measure the clutch lining thickness.  
**Service Limit:** 2.0mm replace if below



Measure the driven face spring free length.  
**Service Limit:**  
82.6mm replace if below

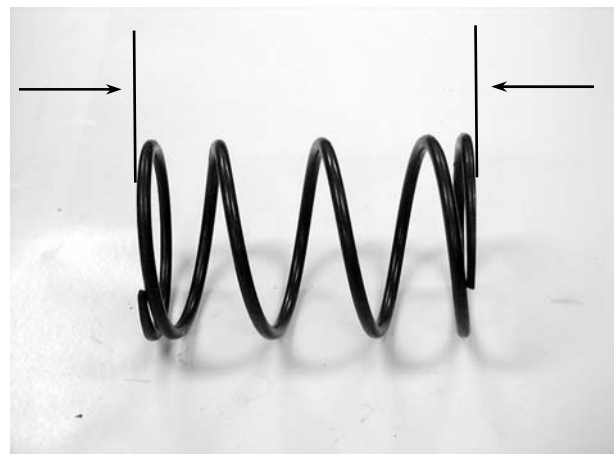

Check the driven face assembly for wear or damage.  
Measure the driven face O.D.  
**Service Limit:** 33.94mm replace if below  
Check the movable driven face for wear or damage.  
Measure the movable driven face I.D.  
**Service Limit:** 34.06mm replace if below  
Check the guide roller pins for stepped wear.

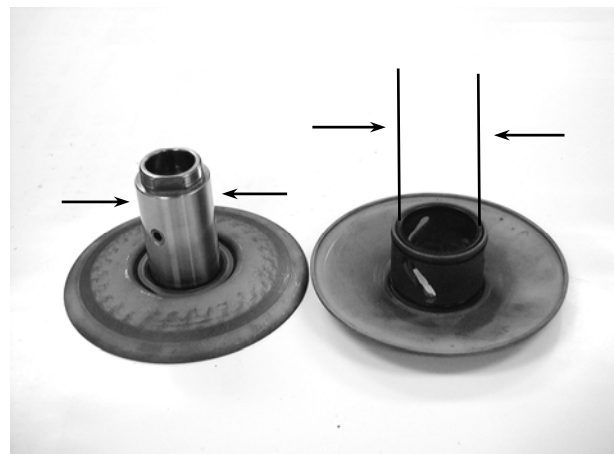

## 8. KICK STARTER/DRIVE PULLEY/ CLUTCH/DRIVEN PULLEY

G-DINK 50

### DRIVEN PULLEY FACE BEARING REPLACEMENT

Check the needle bearings in the driven face and replace them if they have excessive play, damage or abnormal noise. Drive the inner bearing out of the driven pulley face.

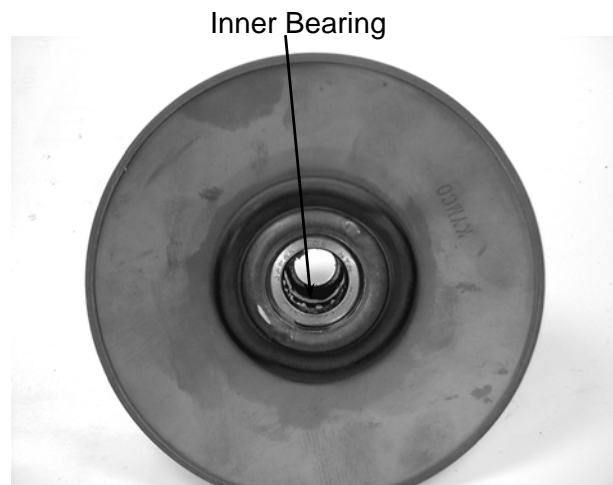

Remove the snap ring and drive the outer bearing out of the driven face.

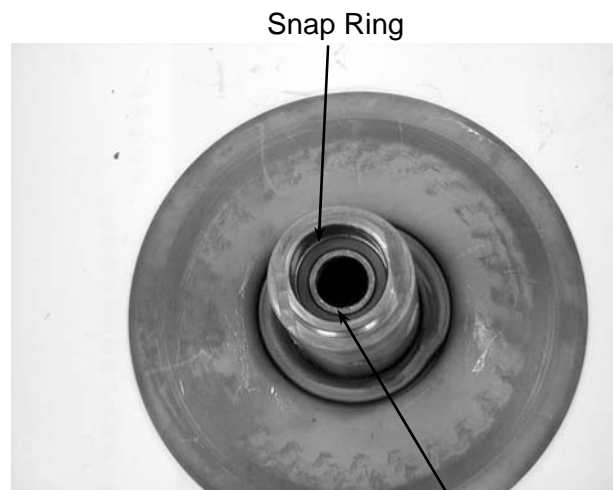

Outer Bearing

Drive a new outer bearing into the driven face with the sealed end facing up. Seat the snap ring in its groove.

\* Pack all bearing cavities with 5.0~5.6g grease.  
Specified grease: 230°C Heat-resistant grease

Bearing Outer Driver, 37x40mm



## 8. KICK STARTER/DRIVE PULLEY/ CLUTCH/DRIVEN PULLEY

G-DINK 50

Drive in a new needle bearing into the driven face with the mark facing up.

Bearing Driver Pilot



Outer Driver, 24x26mm

### CLUTCH/DRIVEN PULLEY ASSEMBLY

First install the movable driven face onto the driven face. Then, install the guide roller pins, O-rings and a new oil seal.

Driven Pulley

Oil Seal

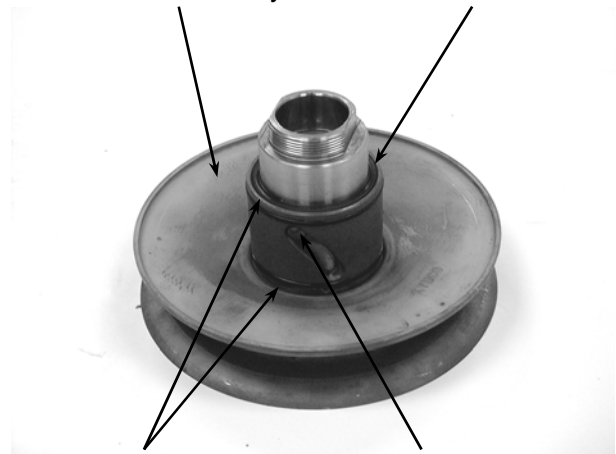

O-rings

Guide Roller Pin

Install the seal collar.

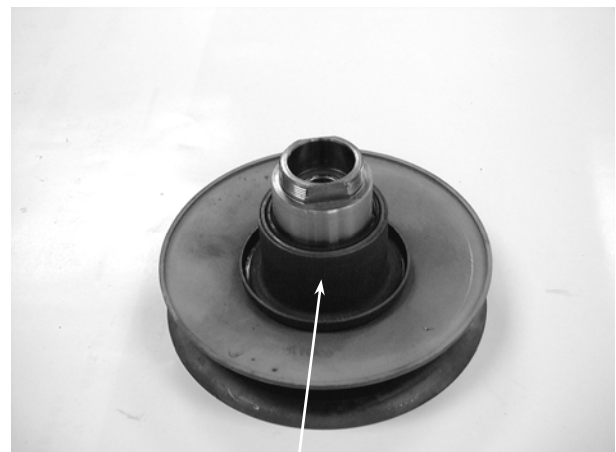

Seal Collar

## 8. KICK STARTER/DRIVE PULLEY/ CLUTCH/DRIVEN PULLEY

G-DINK 50

Set the driven pulley, driven face spring and clutch assembly onto the clutch spring compressor. Compress the tool and install the 28mm drive plate nut. Tighten the 28mm nut to the specified torque.

**Torque:** 5.0~6.0kg-m

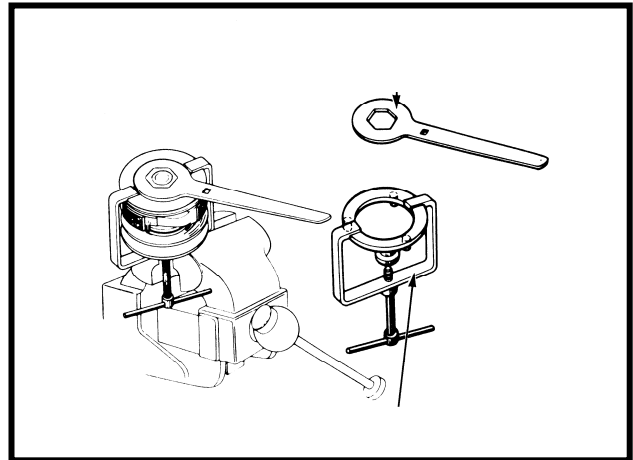

### CLUTCH/DRIVEN PULLEY INSTALLATION

Install the drive belt on the clutch/driven pulley and then install the clutch/driven pulley onto the drive shaft.

Clutch/Driven Outer

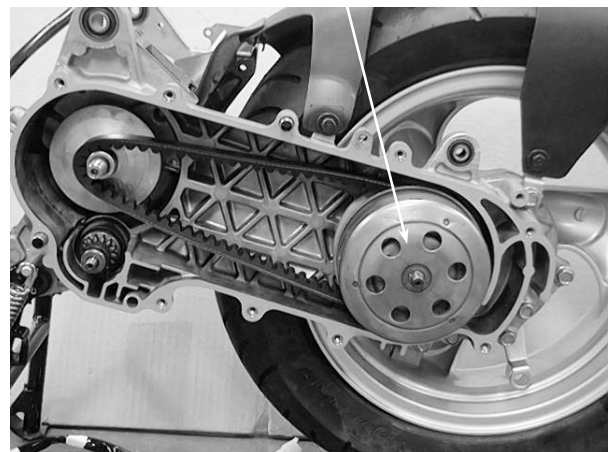

Install the clutch outer.  
Hold the clutch outer with the universal holder.  
Install and tighten the 10mm clutch outer nut.

**Torque:** 3.5~4.5kg-m

Install the left crankcase cover.

Universal Holder



Clutch Outer

---

---

---

---

---

---

---

---

**FINAL REDUCTION**

SERVICE INFORMATION ..... 9-2

TROUBLESHOOTING ..... 9-2

FINAL REDUCTION DISASSEMBLY ..... 9-3

FINAL REDUCTION INSPECTION ..... 9-3

FINAL REDUCTION ASSEMBLY ..... 9-6



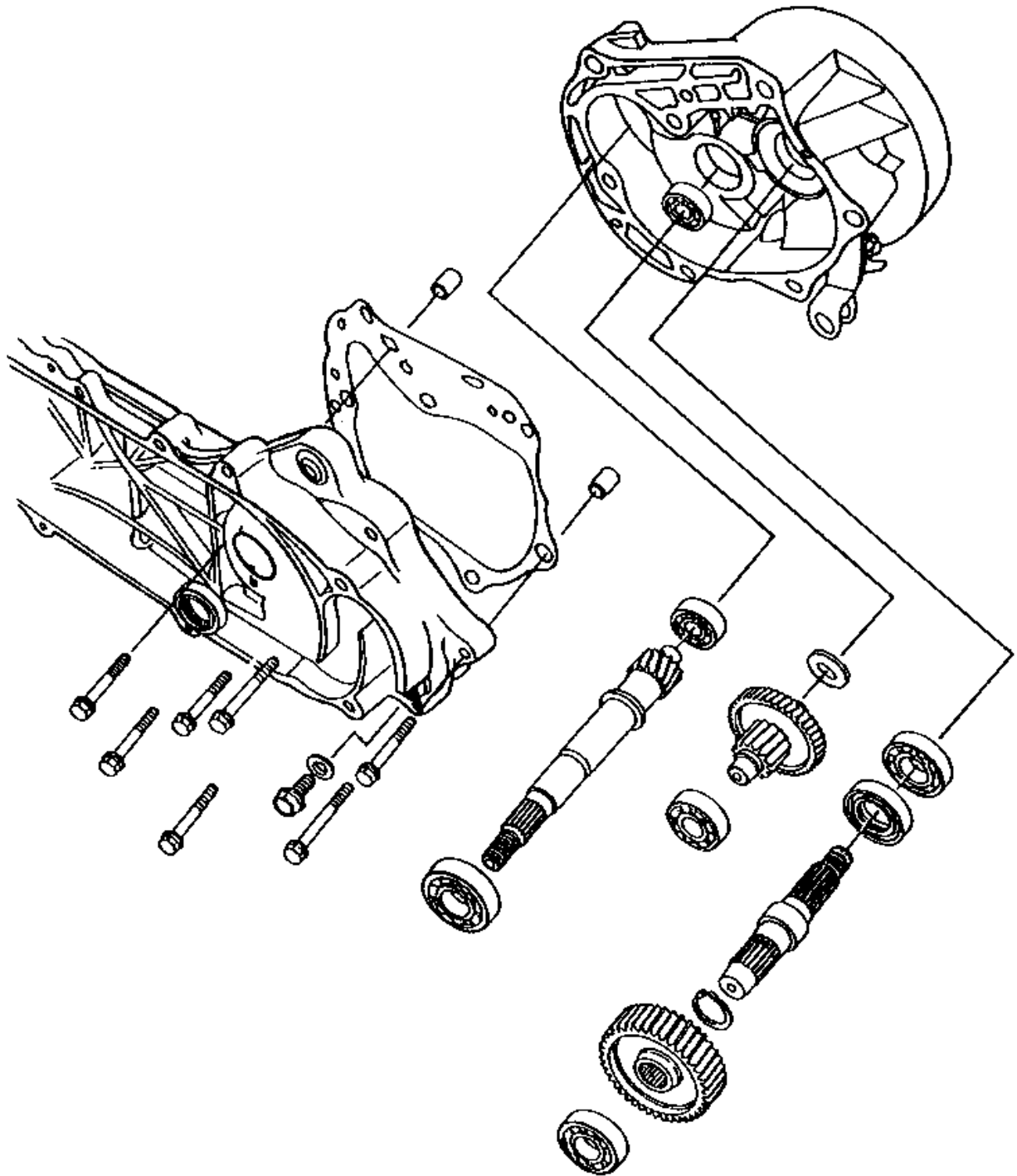

## SERVICE INFORMATION

Specified Oil: SAE90#

At disassembly: 0.23 liter

At change: 0.18 liter

## SPECIAL TOOLS

Bearing remover set, 12mm

Bearing remover set, 15mm

Crankcase assembly collar

Crankcase assembly shaft

Bearing outer driver, 37x40mm

Bearing outer driver, 32x35mm

Bearing driver pilot, 17mm

Bearing driver pilot, 15mm

Bearing driver pilot, 12mm

Bearing outer driver handle A

## TROUBLESHOOTING

### Engine starts but motorcycle won't move

- Damaged transmission
- Seized or burnt transmission

### Abnormal noise

- Worn, seized or chipped gears
- Worn bearing

### Oil leaks

- Oil level too high
- Worn or damaged oil seal

## FINAL REDUCTION DISASSEMBLY

- Remove the rear wheel.
- Remove the left crankcase cover.
- Remove the clutch/driven pulley.
- Drain the transmission gear oil into a clean container.
- Remove the transmission case cover attaching bolts.
- Remove the transmission case cover.
- Remove the gasket and dowel pins.

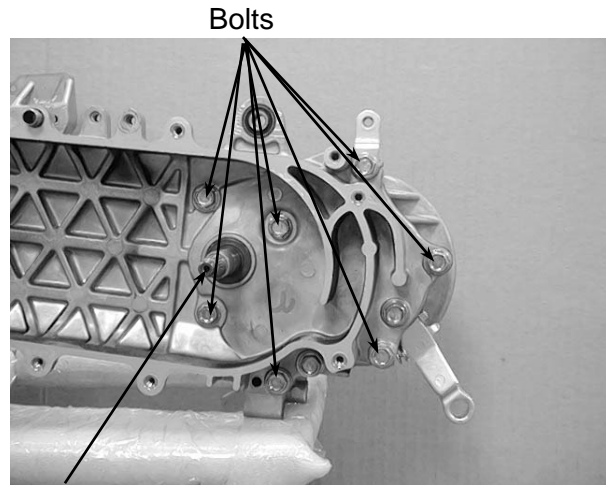

Driver shift

Remove the final gear and countershaft.

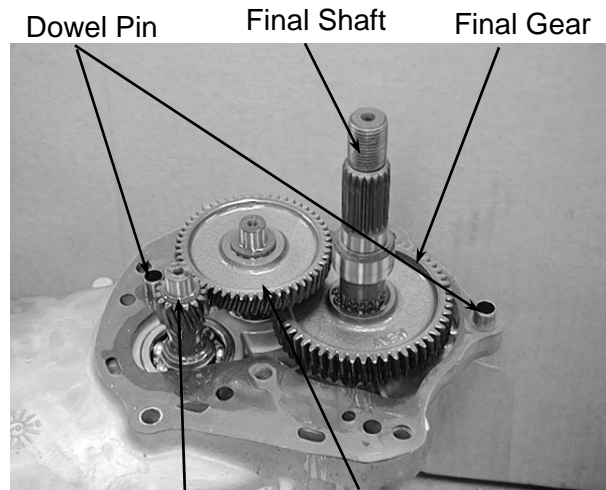

Driver shift

Countershaft

## FINAL REDUCTION INSPECTION

Inspect the countershaft and gear for wear or damage.

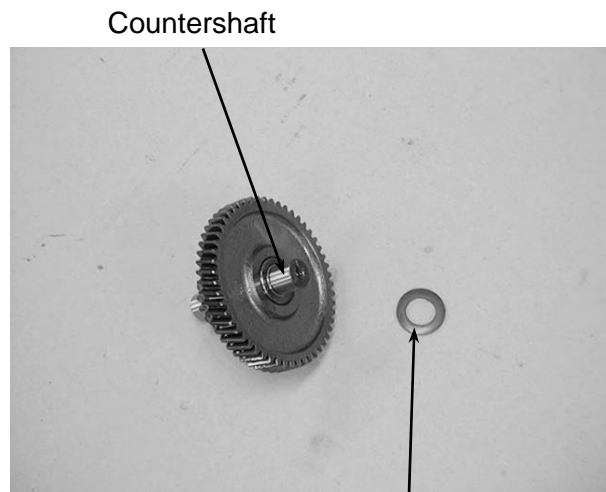

Countershaft

Resin Washer

## 9. FINAL REDUCTION

G-DINK 50

Inspect the final gear and final shaft for wear, damage or seizure.



Check the left crankcase bearings for excessive play and inspect the oil seal for wear or damage.

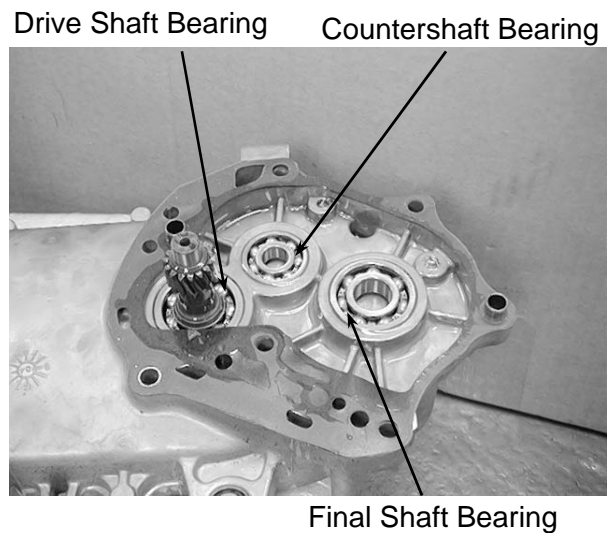

Inspect the drive shaft and gear for wear or damage.  
Check the transmission case cover bearings for excessive play and inspect the final shaft bearing oil seal for wear or damage.

\* Do not remove the transmission case cover except for necessary part replacement. When replacing the drive shaft, also replace the bearing and oil seal.

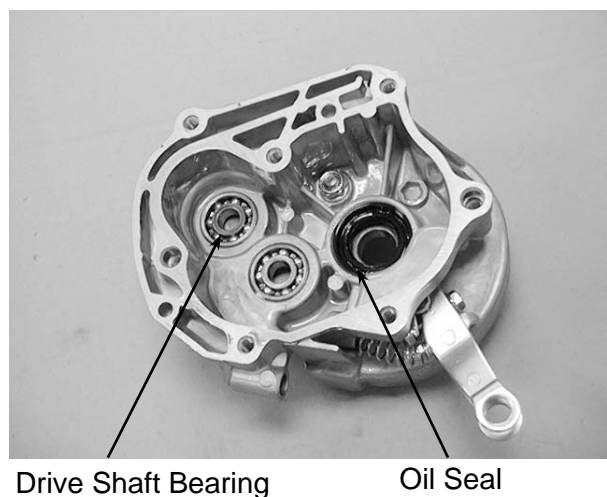

## BEARING REPLACEMENT (Transmission Case Cover)

Remove the transmission case cover bearings using the bearing remover.  
Remove the final shaft oil seal.

Drive Shaft Bearing

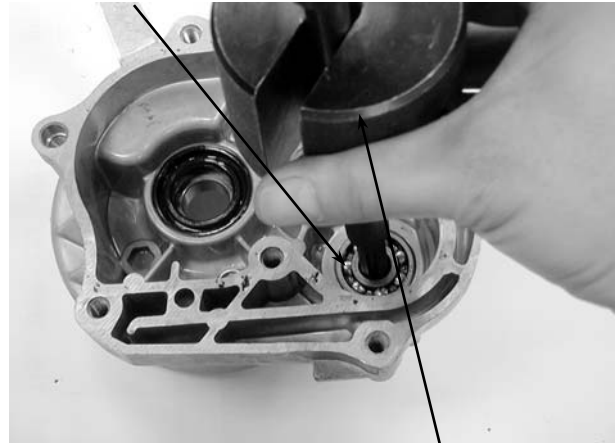

Bearing Remover Set

Drive new bearings into the transmission case cover.

Bearing Outer Driver Handle

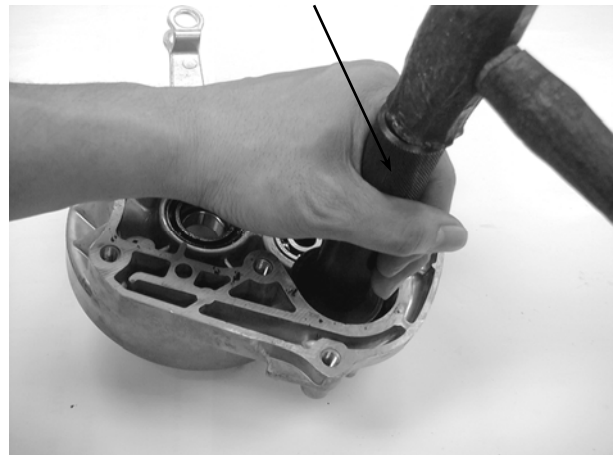

## BEARING REPLACEMENT (Left Crankcase Cover)

Remove the drive shaft.  
Remove the drive shaft oil seal.  
Remove the left crankcase bearings using the bearing remover.



Bearing Remover Set, 12mm

## 9. FINAL REDUCTION

G-DINK 50

Drive new bearings into the left crankcase.  
Install a new drive shaft oil seal.

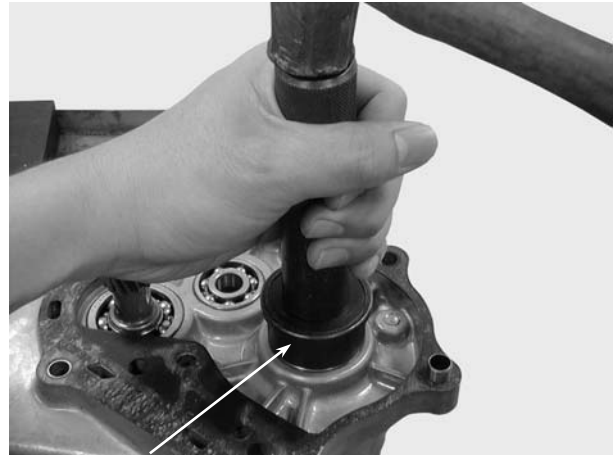

Bearing Outer Driver

### FINAL REDUCTION ASSEMBLY

Install the drive shaft into the left crankcase.

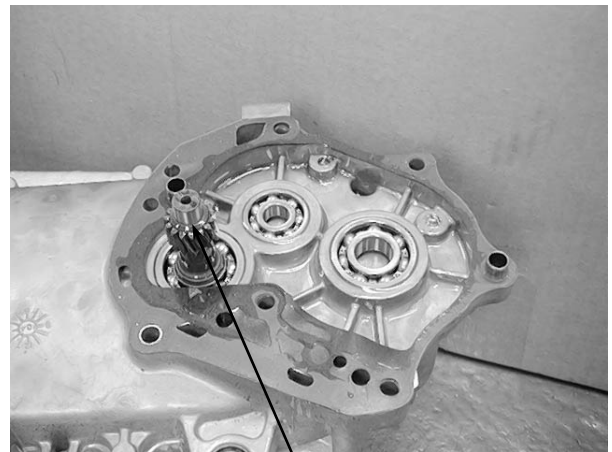

Drive Shaft

Install the final gear and final shaft into the left crankcase.



Final Shaft

## 9. FINAL REDUCTION

G-DINK 50

Install the countershaft and gear into the left crankcase.  
Install the resin washer onto the counter-shaft.  
Install the dowel pins and a new gasket.

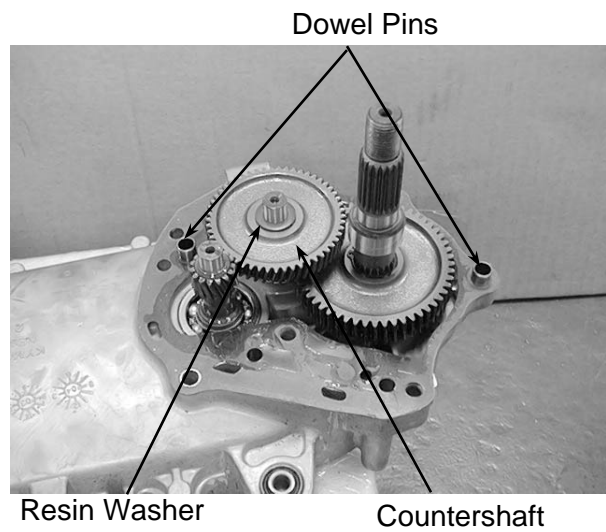

Install the transmission case cover.

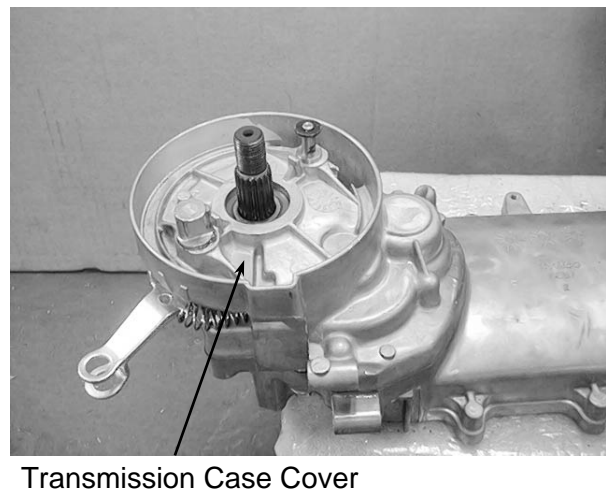

Install and tighten the transmission case cover bolts.  
Install the clutch/driven pulley.  
Install other removed parts in the reverse order of removal.

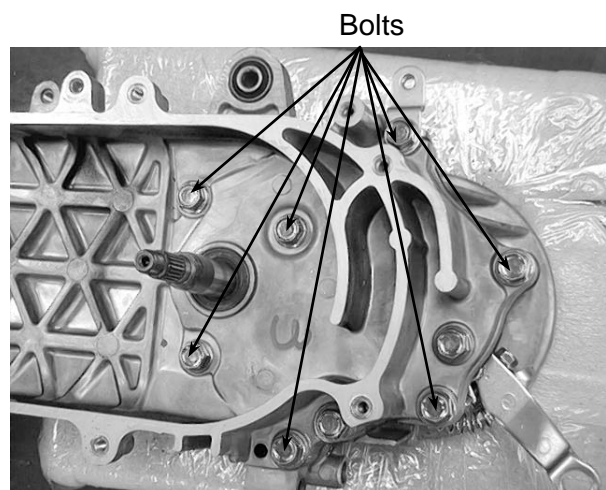

After installation, fill the transmission case with the specified oil.

\*

- Place the motorcycle on its main stand on level ground.
- Check the sealing washer for wear or damage.

**Specified Gear Oil:** SAE90#

**Oil Capacity:** at disassembly: 0.23 liter  
at change: 0.18 liter

Install and tighten the oil check bolt.

**Torque:** 1.0~1.5kg-m

Start the engine and check for oil leaks.  
Check the oil level from the oil check bolt hole and add the specified oil to the proper level if the oil level is low.

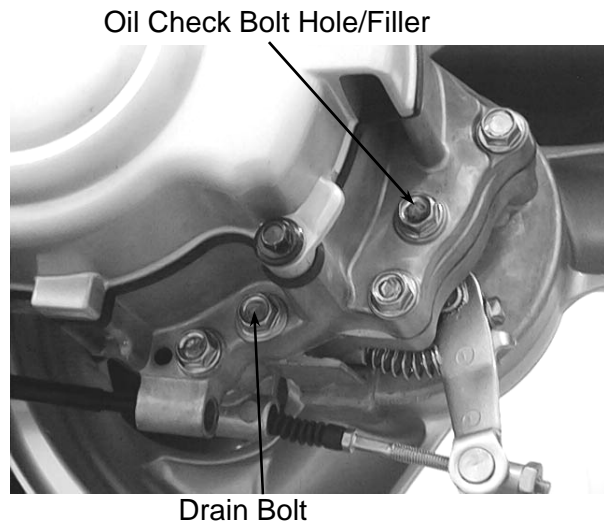

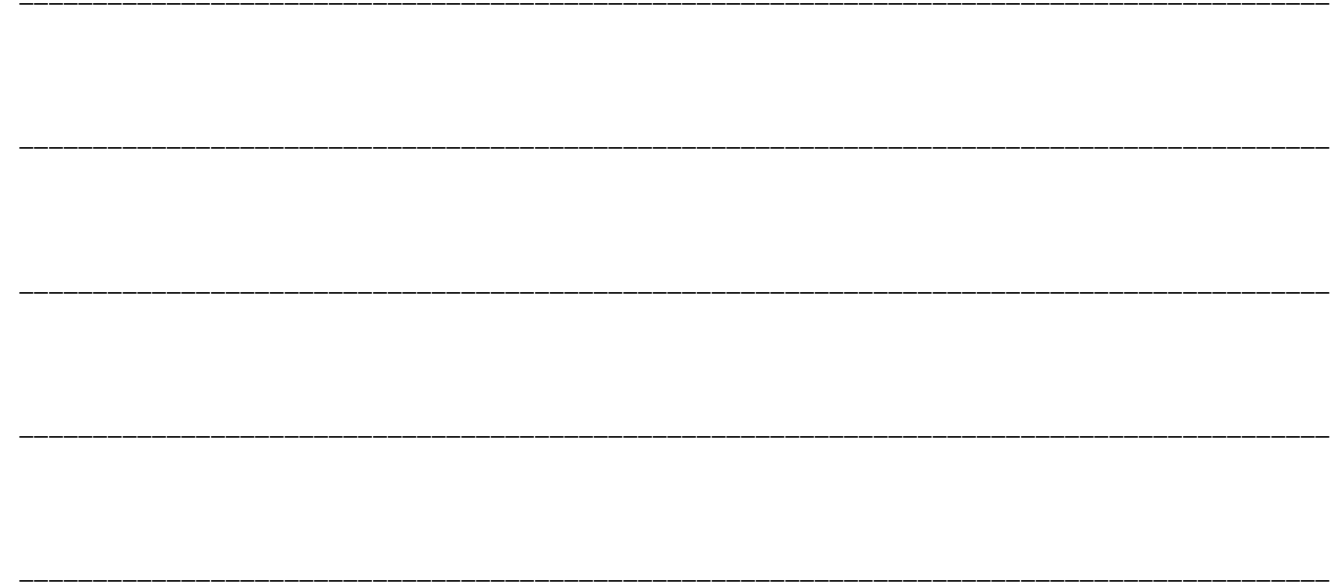

## CRANKCASE/CRANKSHAFT

SERVICE INFORMATION .....	10-2
TROUBLESHOOTING .....	10-2
CRANKCASE SEPARATION .....	10-3
CRANKSHAFT REMOVAL .....	10-3
CRANKSHAFT INSPECTION .....	10-4
CRANKSHAFT INSTALLATION .....	10-5
CRANKCASE ASSEMBLY .....	10-7



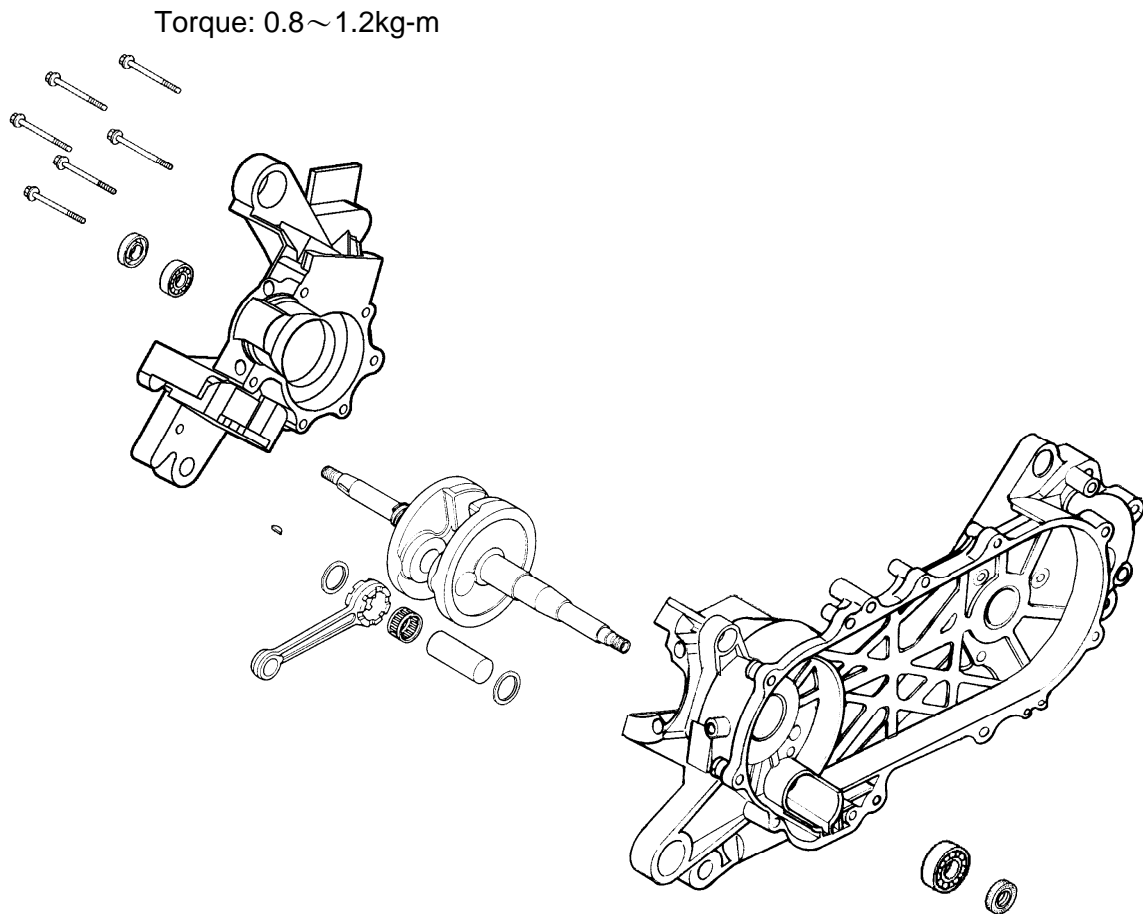

## SERVICE INFORMATION

### GENERAL INSTRUCTIONS

- This section covers crankcase separation to service the crankshaft.
- The following parts must be removed before separating the crankcase.
 

Engine	Driven pulley
Carburetor	A.C. generator
Oil pump	Cylinder head/cylinder
Reed valve	
- When the left crankcase must be replaced, remove the following part in addition to the above.  
Final reduction removal
- Special tools must be used for crankshaft and crankcase assembly. When separating the crankcase, the bearing will remain in the crankcase and it should be removed. When assembling, drive a new bearing into the crankcase and install a new oil seal.

### SPECIFICATIONS

Item	G-DINK 50	
	Standard (mm)	Service Limit (mm)
Connecting rod big end side clearance	—	0.60
Connecting rod big end radial clearance	—	0.04
Crankshaft runout A/B	—	0.15/0.10

### SPECIAL TOOLS

Crankcase puller	Bearing outer driver handle A
Universal bearing puller	Bearing outer driver, 42x47mm
Crankcase assembly collar	Bearing driver pilot, 20mm
Crankcase assembly tool	Bearing outer driver, 37x40mm
	Bearing driver pilot, 17mm

### TROUBLESHOOTING

#### Abnormal engine noise

- Excessive crank journal bearing play
- Excessive crankpin bearing play
- Excessive transmission bearing play

## CRANKCASE SEPARATION

Remove the crankcase attaching bolts.

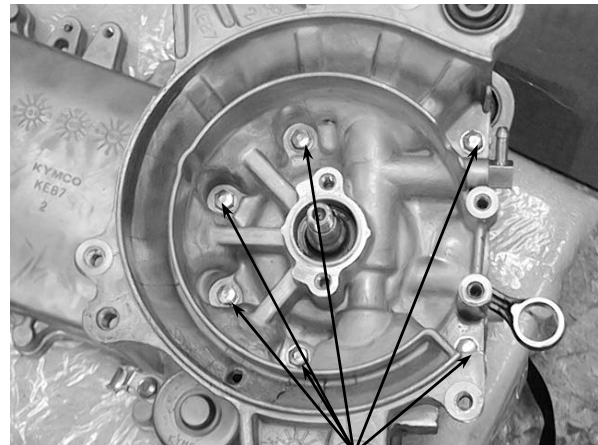

Bolts

Attach the crankcase puller on the right crankcase and remove the right crankcase from the left crankcase.

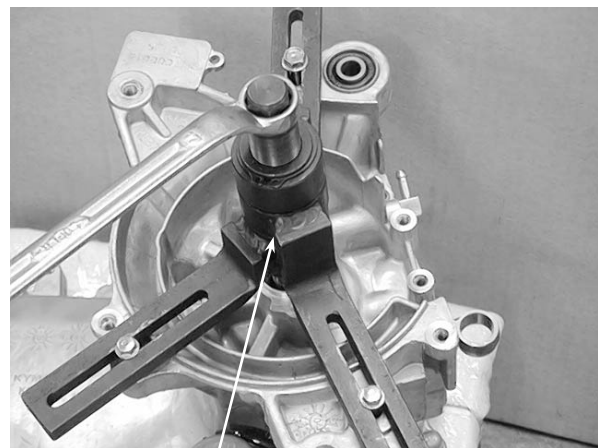

Crankcase Puller

## CRANKSHAFT REMOVAL

Attach the crankcase puller on the left crankcase and remove the crankshaft from the left crankcase.

\* When removing the crankshaft, do it slowly and gently.

Crankcase Puller

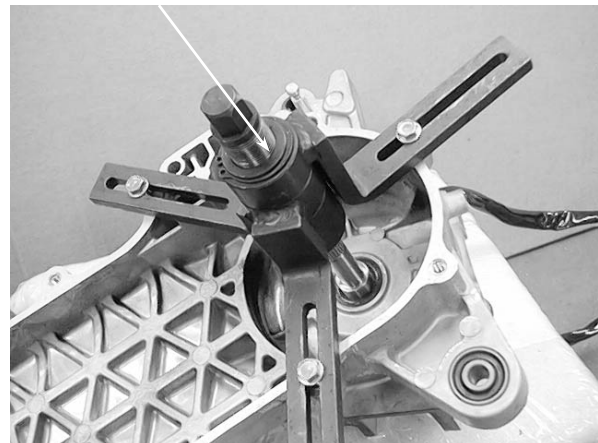

Remove the remaining bearing on the crankshaft side using the universal bearing puller.

\* When separating the crankcase, the oil seals must be removed. Replace the oil seals with new ones.

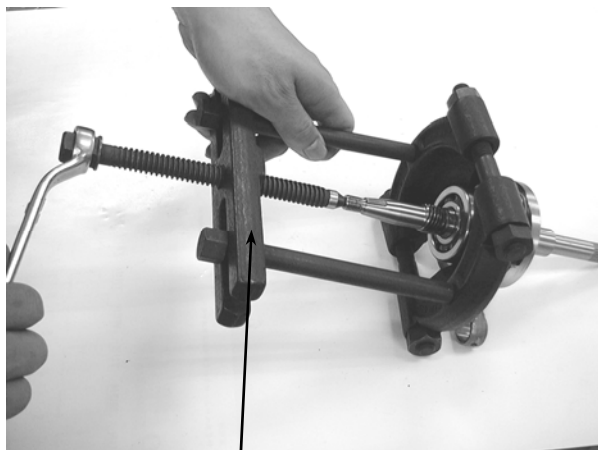

Universal Bearing Puller

## CRANKSHAFT INSPECTION

Measure the connecting rod big end side clearance.

**Service Limit:** 0.6mm replace if over

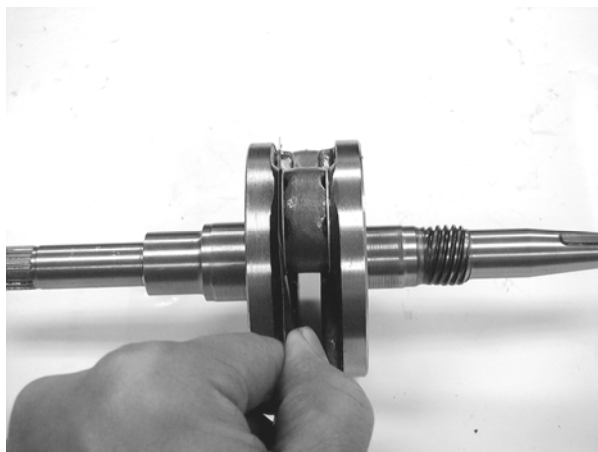

Measure the connecting rod big end radial clearance at two points in the X and Y directions.

**Service Limit:** 0.04mm replace if over

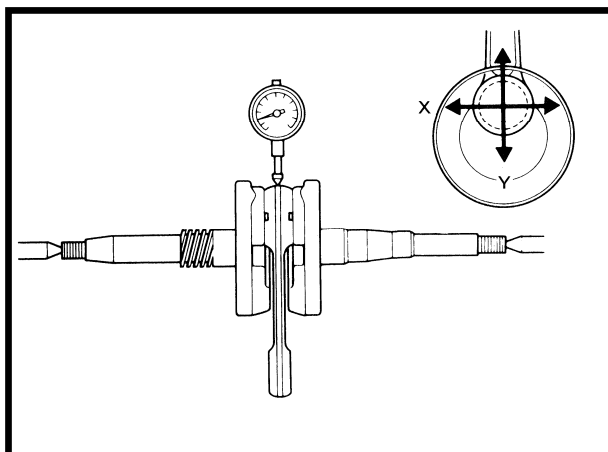

Measure the crankshaft runout.

Service Limit	
A	B
0.150mm replace if over	0.100mm replace if over

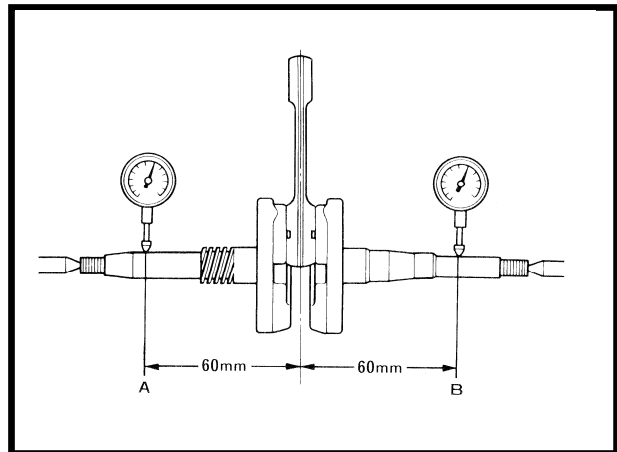

Check the crankshaft bearings for excessive play. The bearings must be replaced if they are noisy or have excessive play.

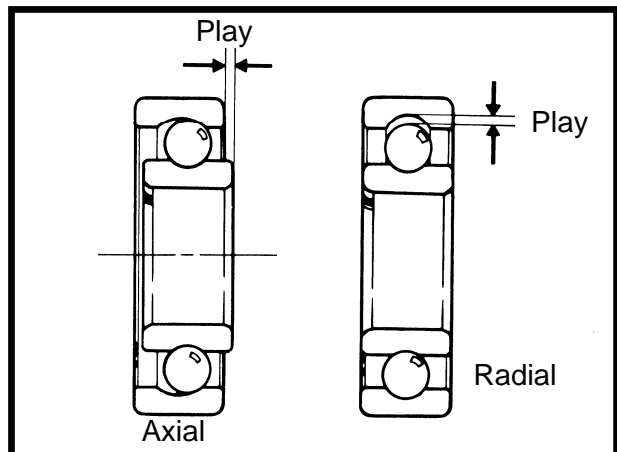

## CRANKSHAFT INSTALLATION

Wash the crankshaft in cleaning solvent and then check for cracks or other faults.

\*

- After check, apply clean engine oil to all moving and sliding parts.
- Remove all gasket material from the crankcase mating surfaces. Dress any roughness or irregularities with an oil stone.



Drive a new crankshaft bearing into the right crankcase.

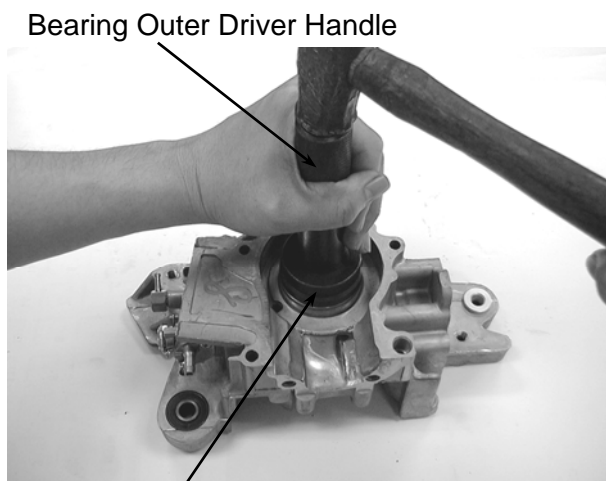

Bearing Outer Driver, 37x40mm  
Bearing Driver Pilot, 17mm

Drive a new crankshaft bearing into the left crankcase.

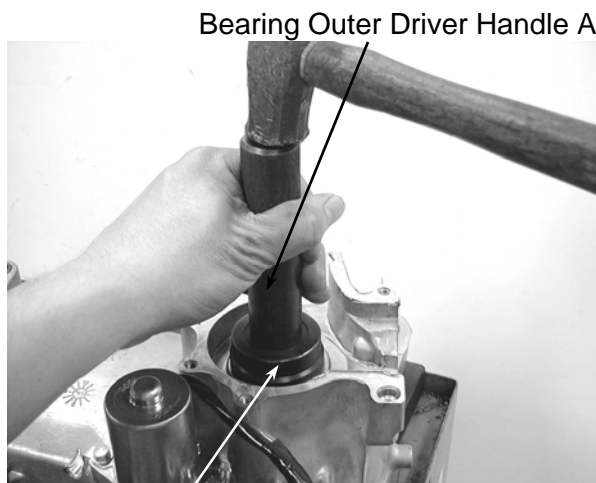

Bearing Outer Driver, 42x47mm  
Pilot, 20mm

Install the crankshaft into the left crankcase.

\*

- Apply KYMCO ULTRA motor oil or molybdenum disulfide to the crank-shaft bearings and connecting rod big end.
- Apply grease to the lip of the oil seal and then install it.

Crankcase Assembly Tool

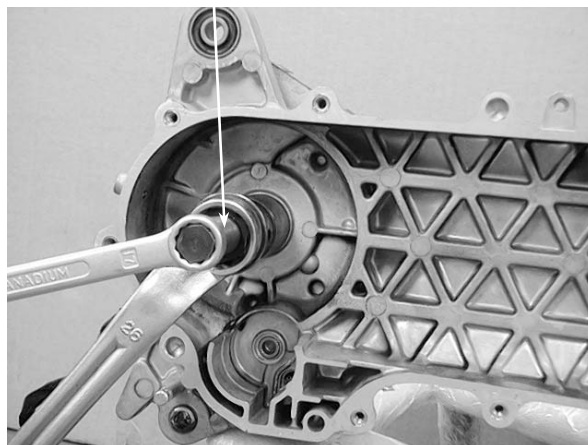

## CRANKCASE ASSEMBLY

Install the dowel pins and a new gasket to the crankcase mating surface.

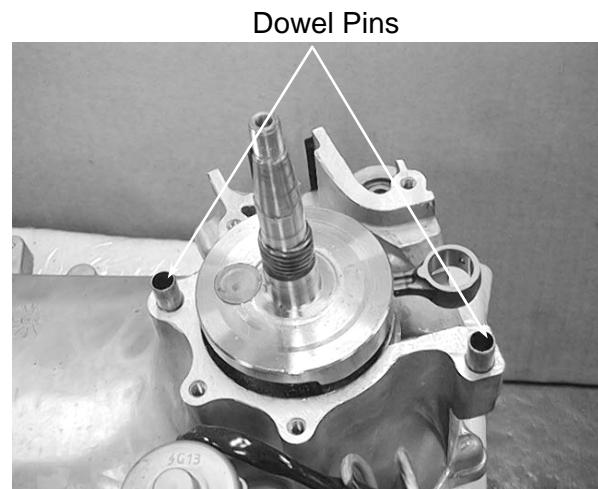

Assemble the crankcase halves.

Crankcase Assembly Tool

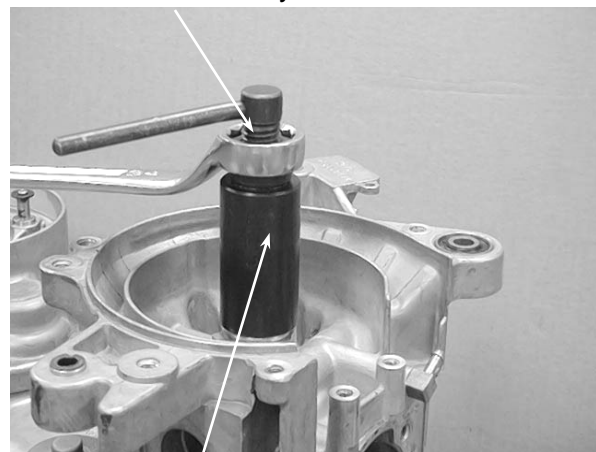

Crankcase Assembly Collar

The distance between the right crankcase oil seal and crankcase surface is about  $12.5 \pm 0.5$  mm.

\*

When installing the oil seal, be careful to press it with even force.

Oil Seal



The distance between the left crankcase oil seal and crankcase surface is about 1.0mm.

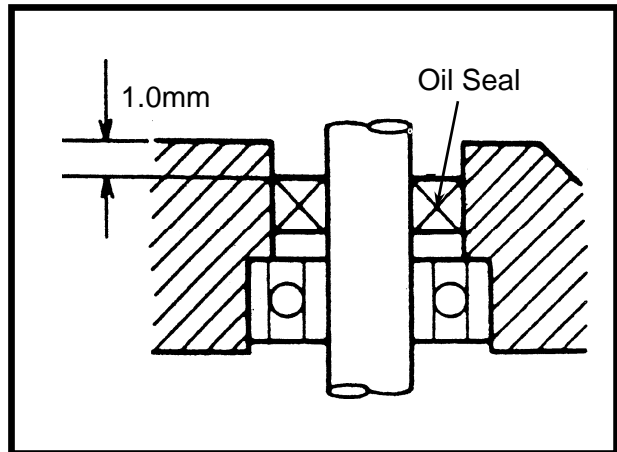

Install and tighten the crankcase attaching bolts.

\* After assembly, check the crankshaft for smooth operation.

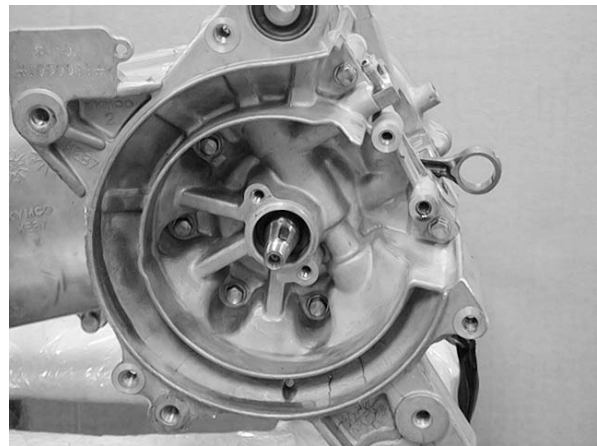

## CARBURETOR

SERVICE INFORMATION .....	11- 2
TROUBLESHOOTING.....	11- 2
THROTTLE VALVE DISASSEMBLY .....	11- 3
THROTTLE VALVE INSTALLATION.....	11- 4
CARBURETOR REMOVAL .....	11- 5
AUTO BYSTARTER .....	11- 6
FLOAT CHAMBER .....	11- 8
FLOAT LEVEL INSPECTION .....	11-10
CARBURETOR INSTALLATION .....	11-11
AIR SCREW ADJUSTMENT .....	11-11
REED VALVE .....	11-12
FUEL TANK.....	11-13



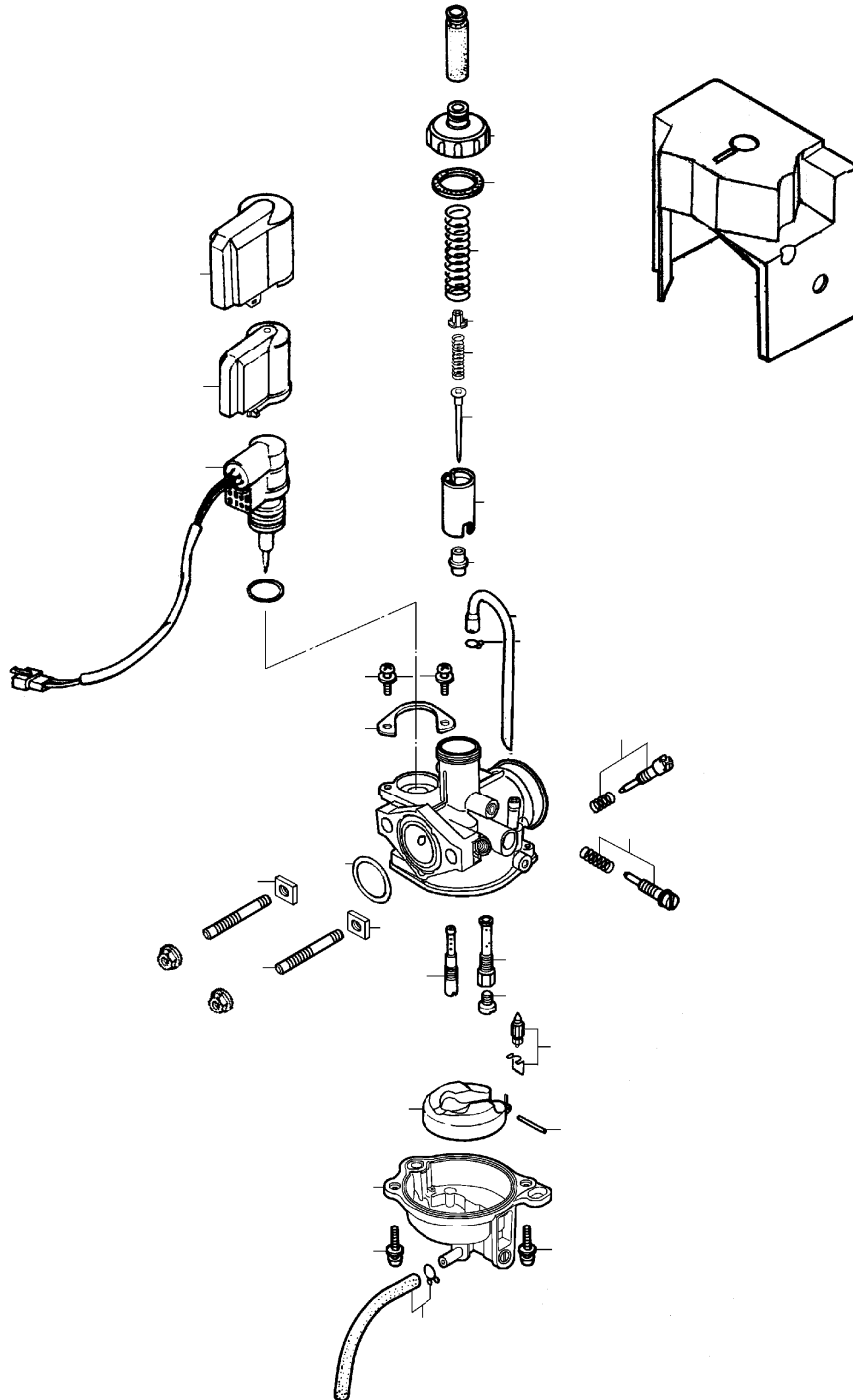

## SERVICE INFORMATION

### GENERAL INSTRUCTIONS

- When working with gasoline, keep away from sparks and flames..
- Note the locations of O-rings when disassembling and replace them with new ones during assembly.
- All cables, fuel lines and wires must be routed and secured at correct locations.
- Bleed air from the oil lines whenever they are disconnected.

### SPECIFICATIONS

	G-DINK 50
Venturi dia.	14mm
Identification number	PB
Float level	8.6mm
Main jet	#75
Slow jet	#35
Air screw opening	1¼ ± ½
Throttle grip free play	2~6mm

### SPECIAL TOOL

Float level gauge

### TROUBLESHOOTING

#### Engine does not start

- No fuel in tank
- Too much fuel getting to cylinder
- Clogged fuel filter
- Clogged air cleaner

#### Lean mixture

- Clogged fuel jets
- Clogged fuel cap vent
- Clogged fuel filter
- Bent, kinked or restricted fuel line

- Faulty float valve
- Float level too low
- Clogged air cleaner

#### Engine idles roughly, stalls or runs poorly

- Incorrect idle speed
- Ignition malfunction
- Compression too low
- Incorrectly adjusted air screw
- Incorrect float level
- Clogged air cleaner
- Intake air leaks
- Fuel contaminated
- Faulty reed valve
- Clogged fuel jets

#### Rich mixture

- Faulty float valve
- Float level too high
- Clogged air jets

## THROTTLE VALVE DIS-ASSEMBLY

Remove the rear carrier.  
Remove the met-in box.  
Remove the rubber cover.  
Loosen carburetor cap and the throttle valve.

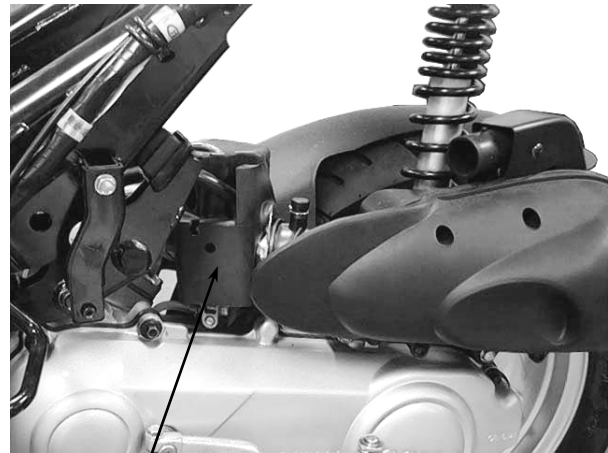

Rubber Cover

Disconnect the throttle cable from the throttle valve.

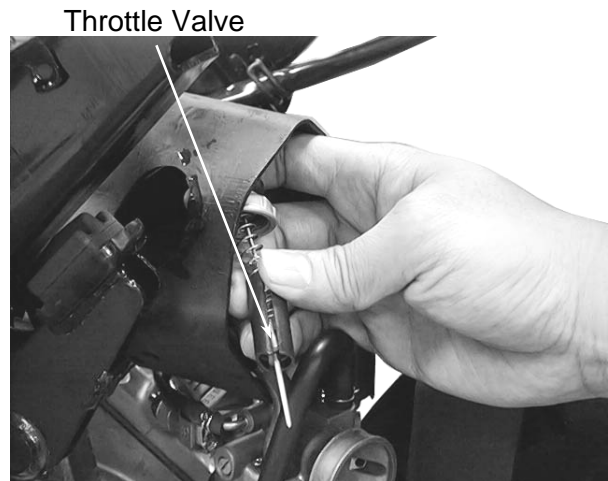

Throttle Valve

Remove the throttle valve spring, carburetor cap and rubber seal.

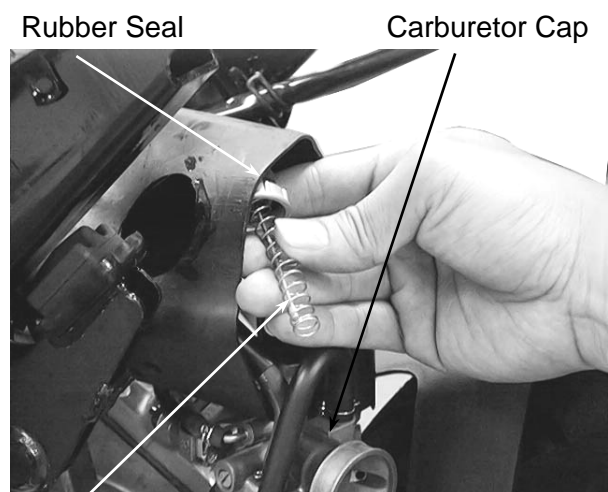

Rubber Seal

Carburetor Cap

Spring

Remove the jet needle by removing the needle clip.  
Check the jet needle and throttle valve for wear or damage.

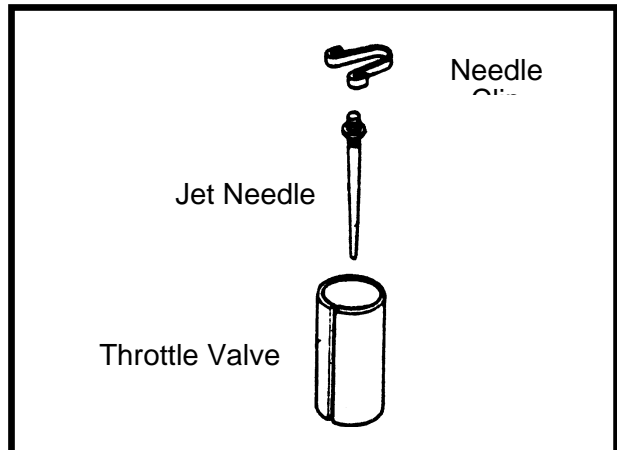

### THROTTLE VALVE INSTALLATION

Install the jet needle on the throttle valve and secure with the needle clip.

Install the rubber seal on the throttle cable and then install the carburetor cap and throttle valve spring.

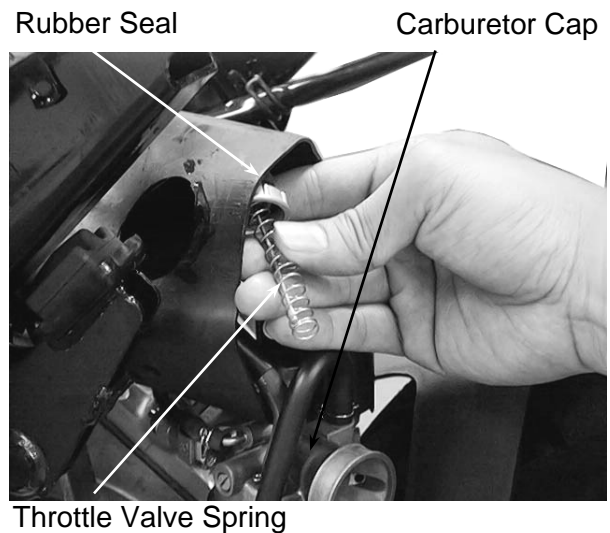

Connect the throttle cable to the throttle valve.

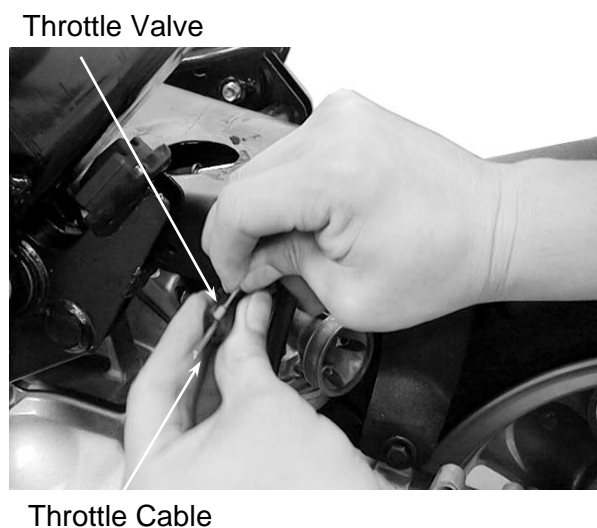

Install the throttle valve by aligning the groove in the throttle valve with the throttle stop screw.

Groove

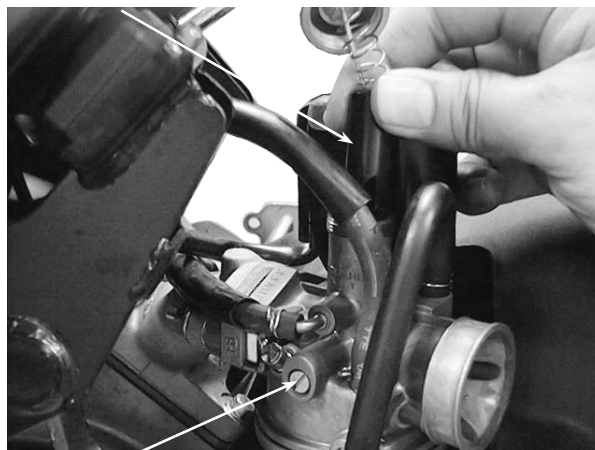

Throttle Stop Screw

Tighten the carburetor cap.  
After installation, perform the following adjustments and inspections.

- Throttle cable free play
- Idle speed adjustment

Install the met-in box.

Carburetor Cap

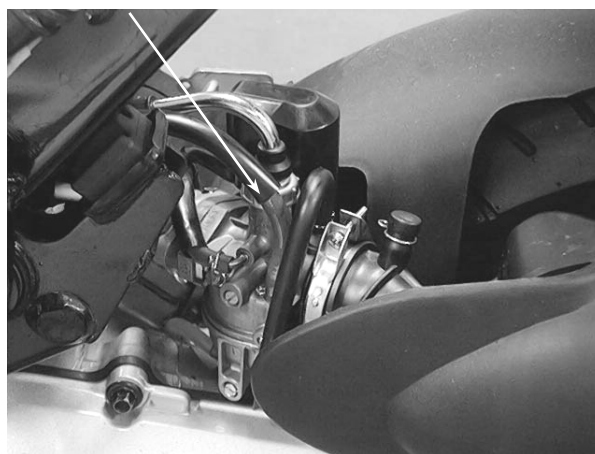

## CARBURETOR REMOVAL

Remove the met-in box.  
Remove the air cleaner by removing the air cleaner band screw and attaching bolts.  
Disconnect the fuel tube.  
Loosen the drain bolt to drain fuel from the carburetor.  
Disconnect the auto bystarter wire connector.  
Remove the two carburetor lock nuts.

Throttle Cable    Auto Bystarter    Fuel Tube

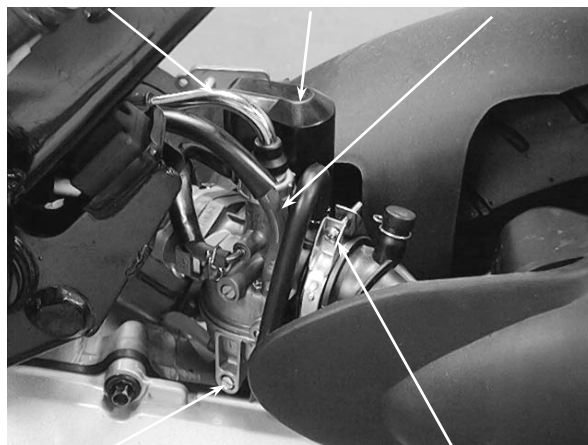

Drain Bolt

Band

Remove the carburetor.

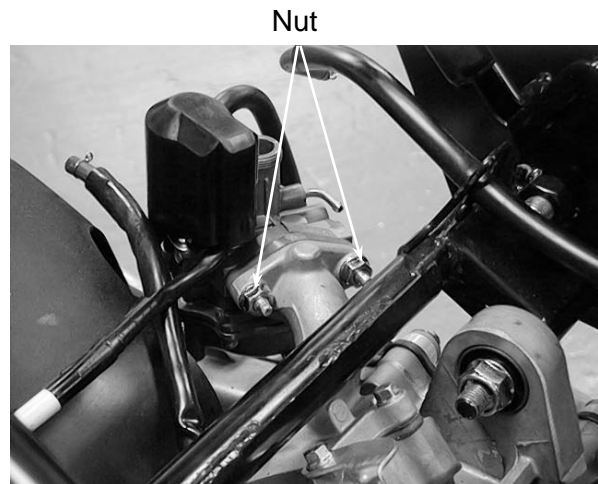

### AUTO BYSTARTER

#### AUTO BYSTARTER INSPECTION

Measure the resistance between the auto bystarter wire terminals.

**Resistance:**  $5\Omega$  (10 minutes minimum after stopping the engine)

If the resistance exceeds  $5\Omega$ , replace the auto bystarter with a new one.

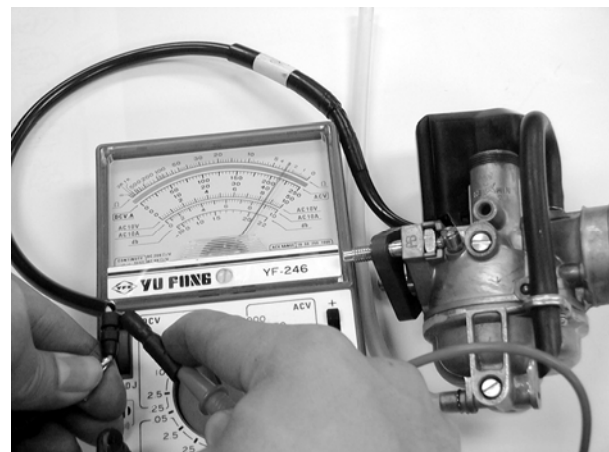

After the engine stops for 30 minutes, connect a hose to the fuel enriching circuit and blow the hose with mouth.

If air cannot be blown into the hose (clogged), the auto bystarter is faulty. Replace it with a new one.

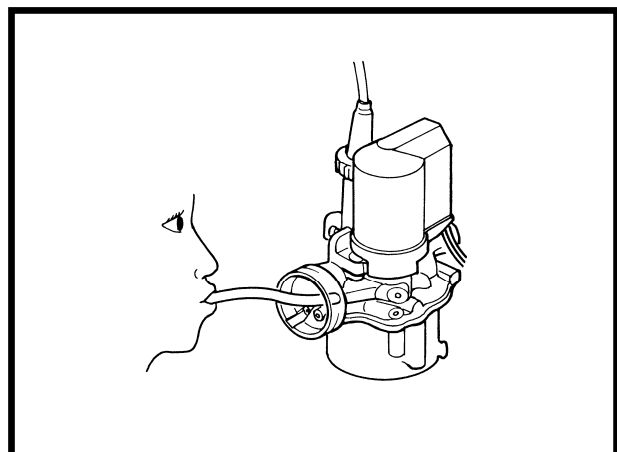

Connect the auto bystarter yellow wire to the battery positive (+) terminal and green/black wire to the battery negative (-) terminal and wait 5 minutes.

Connect a hose to the fuel enriching circuit and blow the hose with mouth.

If air can be blown into the hose, the auto bystarter is faulty and replace it with a new one.

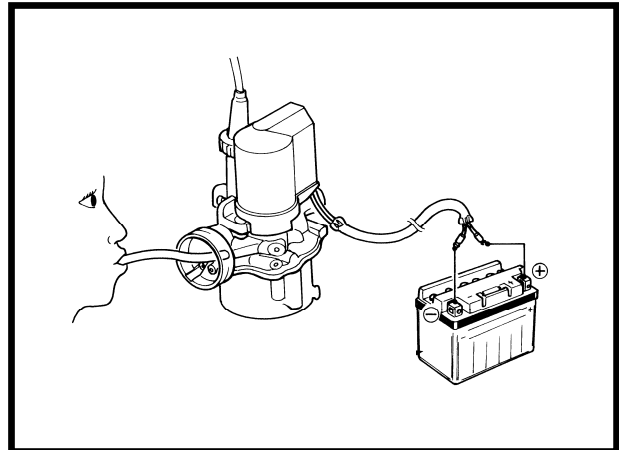

## AUTO BYSTARTER REMOVAL

Remove the auto bystarter cover.  
Remove the two auto bystarter set plate screws to remove the auto bystarter.

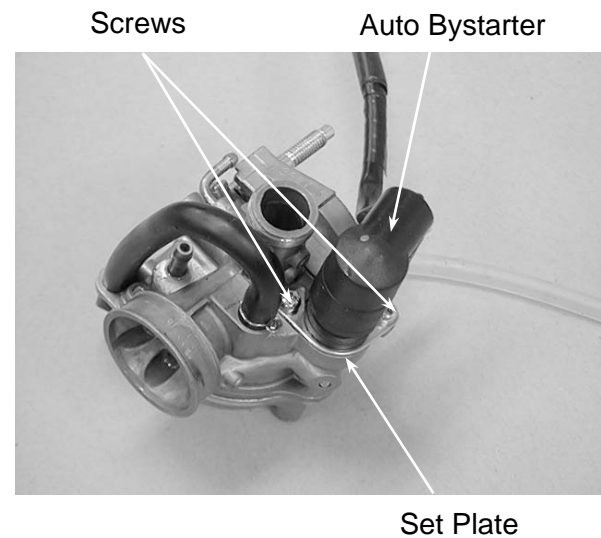

Check the auto bystarter valve and needle for wear or damage.

Check the O-ring for wear or damage.

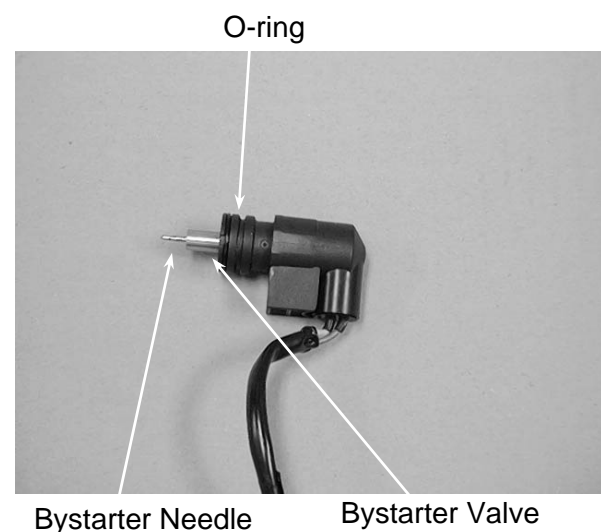

### AUTO BYSTARTER INSTALLATION

Install the auto bystarter into the carburetor body until it bottoms..  
Install the set plate and then tighten the two screws.

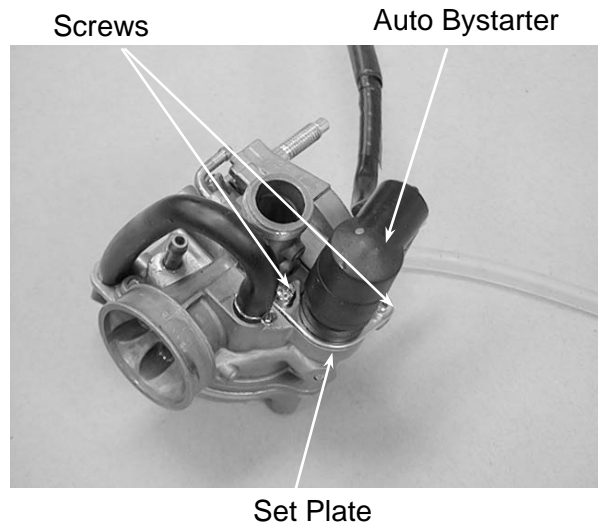

### FLOAT CHAMBER

Remove the two float chamber screws and the float chamber.

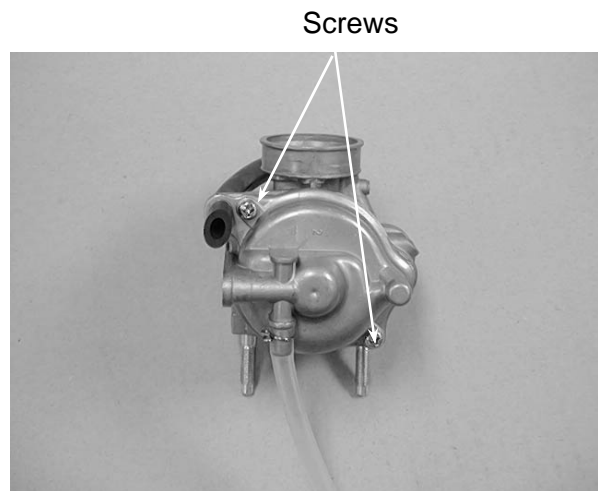

Remove the screw and O-ring.  
Remove the float pin, float and float valve.

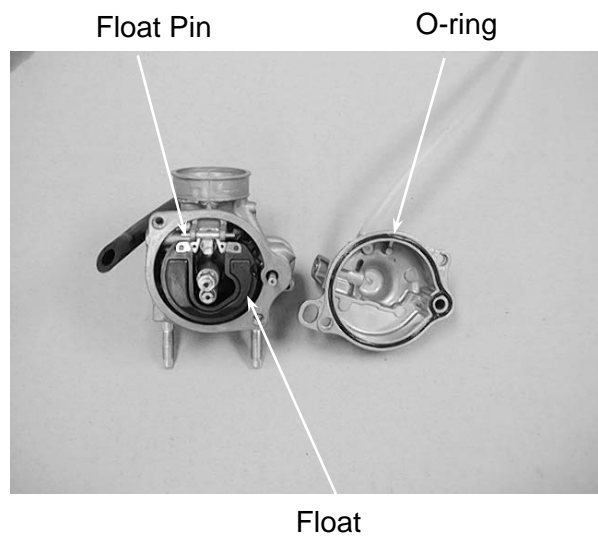

## FLOAT/FLOAT VALVE INSPECTION

Inspect the float for damage or fuel inside the float.

Check the float valve seat for wear or damage.

Float Valve

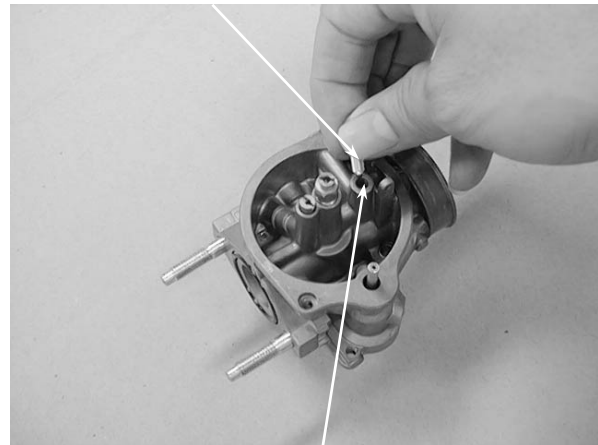

Float Seat

## JETS/SCREWS REMOVAL

Before removing the throttle stop screw or air screw, record the number of rotations until it seats lightly. Then, remove them.

\*

Do not force the air screw against its seat to prevent damage.

Remove the main jet and needle jet holder.

Main Jet

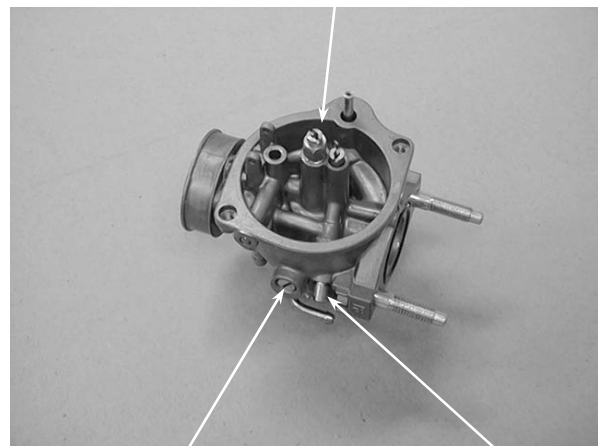

Throttle Stop Screw

Air Screw

## CARBURETOR PASSAGES CLEANING

Blow compressed air through all passages of the carburetor body with an air gun.

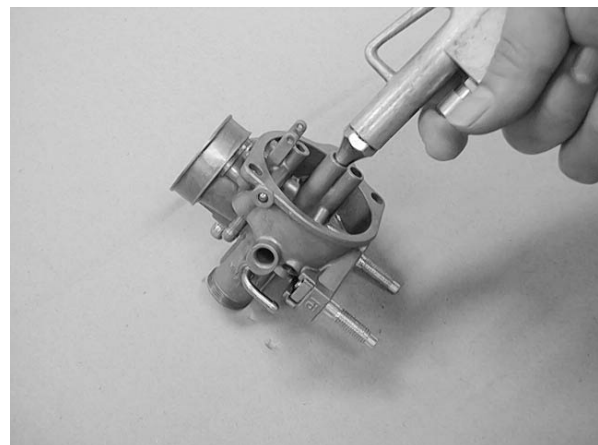

### FLOAT CHAMBER ASSEMBLY

Install the main jet and needle jet holder.  
Install the air screw and throttle stop screw according to the rotations recorded.

\*

If the air screw must be replaced, be sure to perform the air screw adjustment again.

Needle Jet holder Main Jet

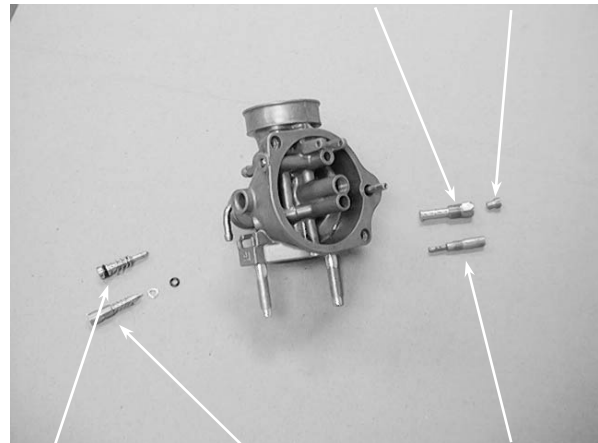

Air Screw Throttle Stop Screw Slow Jet

Install the float valve, float and float pin.  
Tighten the float screw securely.

Float Pin

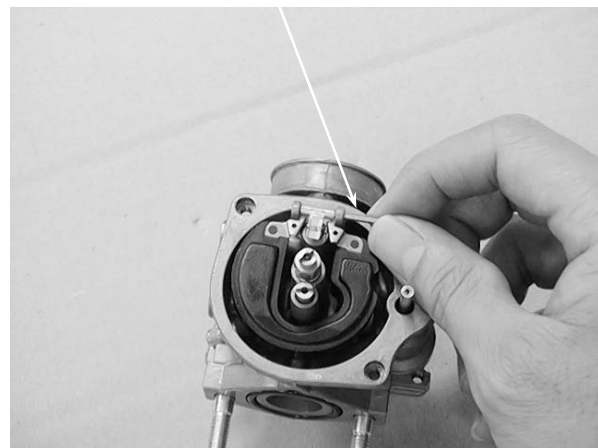

### FLOAT LEVEL INSPECTION

Slightly tilt the carburetor and measure the float level with the float valve just connecting the float arm.

**Float Level:** 8.6mm

Replace the float if the level is out of the specified level range.

Install the O-ring.

Check the operation of the float and install the float chamber.

Tighten the screws.

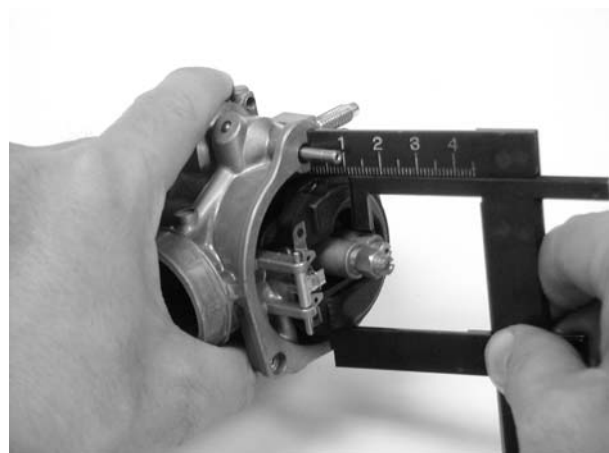

## CARBURETOR INSTALLATION

\* When installation, do not allow foreign particles to enter the carburetor.

Check the carburetor insulator and O-ring for wear or damage.  
 Install the carburetor and insulator onto the intake manifold and tighten the two lock nuts.  
 Connect the fuel tube and auto bystarter wire connector.

\* Route the auto bystarter wire correctly and properly.

Install the carburetor cap.  
 Install the air cleaner onto the carburetor and tighten the band screw.  
 Install the met-in box.

## AIR SCREW ADJUSTMENT

Remove the met-in box.

\* Warm up the engine before air screw adjustment.

Turn the air screw clockwise until it seats lightly and back it to the specification given.

### Air Screw Opening:

:  $1\frac{1}{4} \pm \frac{1}{2}$  turns

Start the engine and turn the air screw in or out slowly to obtain the highest engine speed.

\* Do not force the air screw against its seat to prevent damage.

Turn the throttle stop screw to obtain the specified idle speed.

### Idle Speed:

:  $1700 \pm 100$ rpm

Slightly increase the engine speed and make sure that the engine does not miss or run erratic.

If the adjustment of the air screw within the range of  $\pm \frac{1}{2}$  turn makes no difference to the engine performance, check other related items.

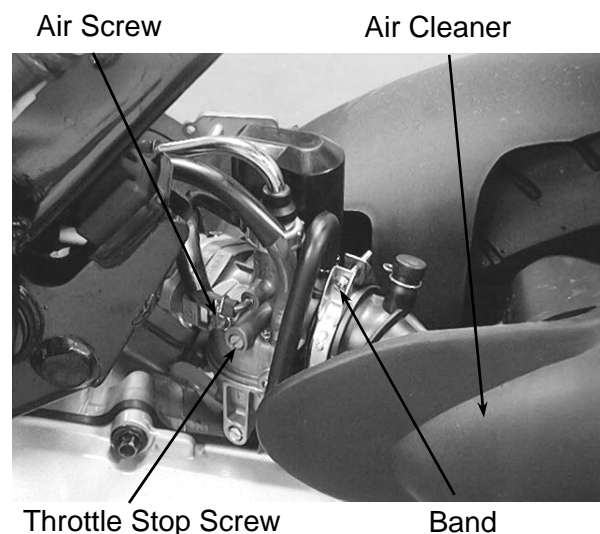
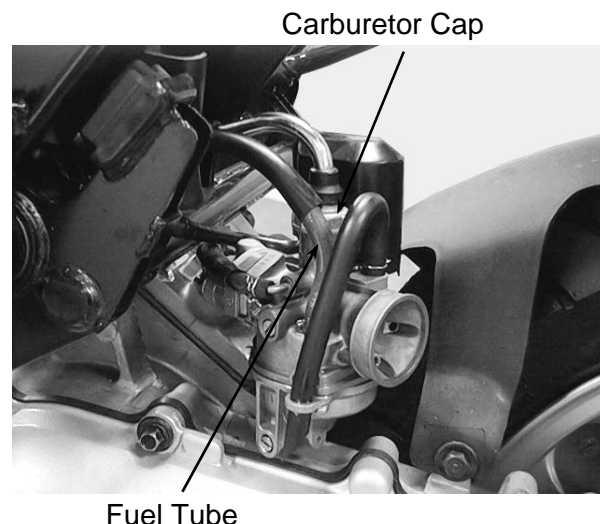
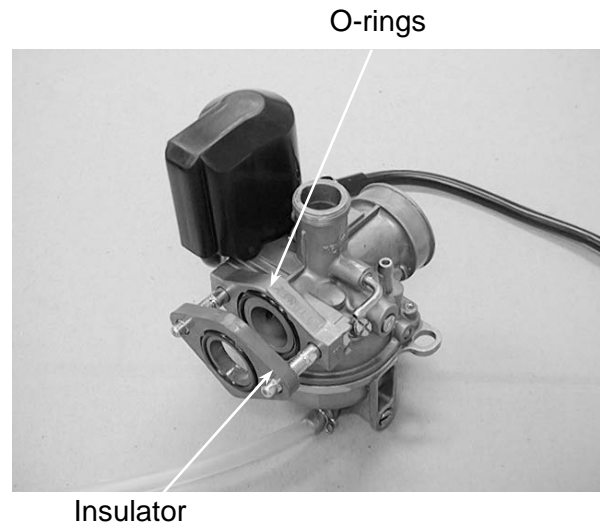

### REED VALVE

#### REMOVAL

Remove the rear carrier.  
Remove the frame body cover.  
Remove the four intake manifold bolts and gasket.  
Remove the reed valve and gasket.

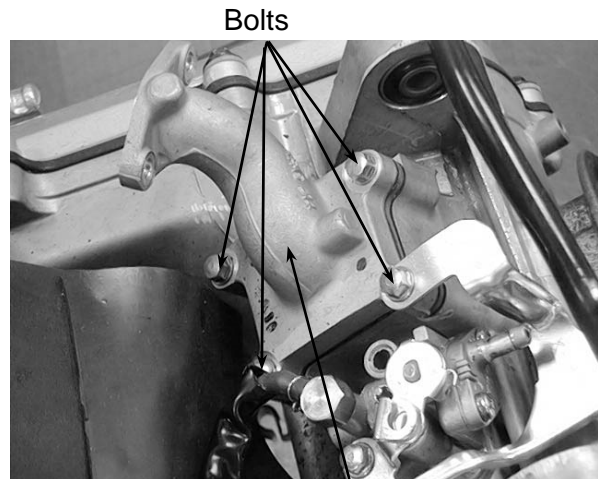

Intake Manifold

#### INSPECTION

Check the reed valve for damaged or weak reeds.  
Check the reed valve seat for cracks, damage or clearance between the seat and reed.  
Replace the valve if necessary.

\* Do not disassemble or bend the reed stopper. To do so can cause loss of engine power and engine damage. If any of the stopper, reed or valve seat is faulty, replace them as a unit.

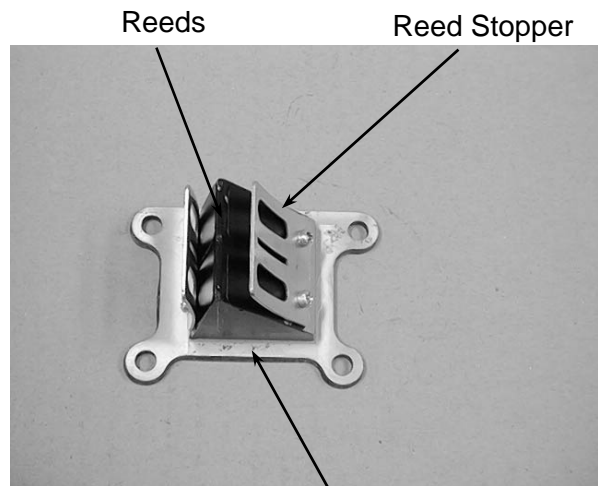

Reed Valve Seat

#### INSTALLATION

Install the reed valve in the reverse order of removal.

\*

- Install a new gasket with the gasket indentation aligned with the reed valve.
- After installation, check for intake air leaks.

### FUEL TANK

#### FUEL PUMP REMOVAL

Remove the met-in box.  
Remove the frame body cover.  
Remove the rear carrier.  
Disconnect the fuel pump inlet, outlet and vacuum tubes.  
Remove the two fuel pump attaching bolts and the fuel pump.

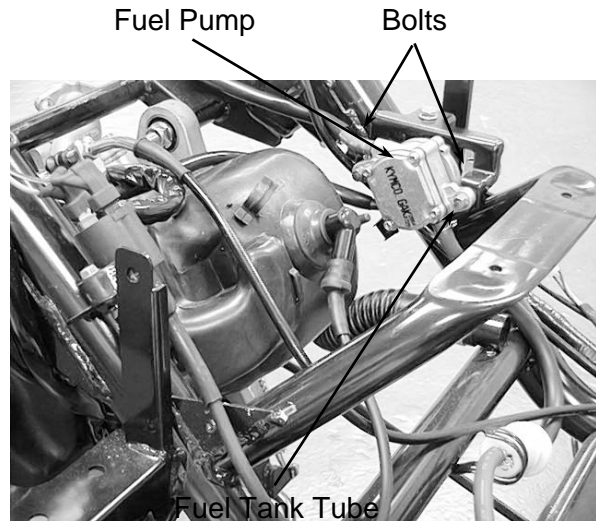

#### FUEL PUMP INSTALLATION

Install the fuel pump and secure it with the two bolts.  
Connect the fuel pump inlet, outlet and vacuum tubes.  
Install the seat, met-in box and frame center cover.

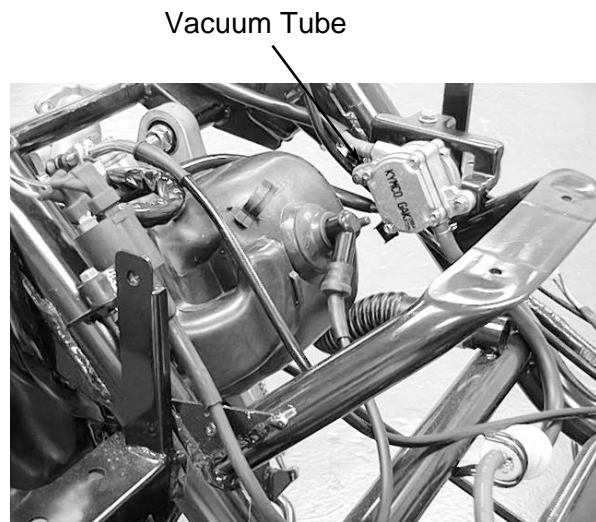

### FUEL TANK REMOVAL

- Remove the floor board.
- Remove the leg shield.
- Disconnect the fuel unit wire connector.
- Remove the fuel tube between the fuel tank and the fuel filler.
- Disconnect the fuel vapor tube.
- Remove the fuel tank.
- The installation sequence is the reverse of removal.

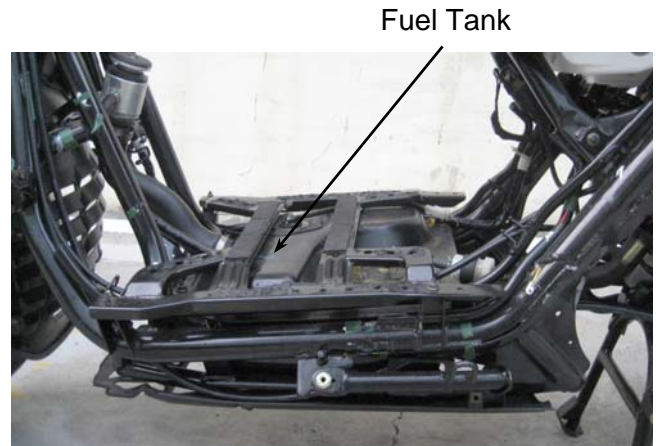

### FUEL STRAINER REMOVAL

- Remove the fuel strainer from the fuel tank.

#### Inspection

Inspect if the fuel strainer is clogged and clean it with compressed air.

\* \_\_\_\_\_

- When removing the fuel strainer, do not allow flames or sparks near the working area and drain the residual gasoline into a container.



### INSTALLATION

- Install the fuel strainer with its arrow mark toward the fuel pump.

---

**HANDLEBAR/FRONT WHEEL/FRONT BRAKE/  
FRONT SHOCK ABSORBER/STEERING STEM**

---

SERVICE INFORMATION-----	12- 1
TROUBLESHOOTING-----	12- 2
HANDLEBAR -----	12- 3
FRONT WHEEL -----	12- 6
FRONT BRAKE FLUID-----	12- 9
FRONT BRAKE PAD -----	12-11
BRAKE DISC INSPECTION -----	12-12
FRONT SHOCK ABSORBER-----	12-13
STEERING STEM-----	12-14

**SERVICE INFORMATION**

**GENERAL INSTRUCTIONS**

- Remove the motorcycle frame covers before removing the front wheel, steering handlebar, front shock absorber and front fork. Jack the motorcycle front wheel off the ground and be careful to prevent the motorcycle from falling down.
- During servicing, keep oil or grease off the brake pads and brake disk.

**TORQUE VALUES**

Handlebar post	6.0~7.0 kgf-m
Steering stem lock nut	6.0~6.5 kgf-m
Front axle	1.5~2.5 kgf-m
Brake caliper mounting bolt	3~4 kgf-m
Brake caliper bleed screw	0.4~0.7 kgf-m

**TROUBLESHOOTING**

**Hard steering (heavy)**

- Excessively tightened steering stem top cone race
- Broken steering balls
- Insufficient tire pressure

**Steers to one side or does not track straight**

- Uneven front shock absorbers
- Bent front fork
- Bent front axle or uneven tire

**Poor brake performance**

- Worn brake pads
- Contaminated brake pad surface
- Deformed brake disk
- Air in brake system
- Deteriorated brake fluid
- Worn brake master cylinder piston oil seal
- Clogged brake fluid line
- Unevenly worn brake caliper

**Front wheel wobbling**

- Bent rim
- Loose front axle
- Bent spoke plate
- Faulty tire
- Improperly tightened axle nut

**Soft front shock absorber**

- Weak shock springs
- Insufficient damper oil

**Front shock absorber noise**

- Slider bending
- Loose fork fasteners
- Lack of lubrication

## HANDLEBAR

### REMOVAL

Remove the lower handlebar cover and front cover.

Remove two bolts and disconnect the brake light switch wire, then remove the rear brake master cylinder.

Remove the two bolts and disconnect the brake light switch wire, then remove the front brake master cylinder.

Remove the inner cover.



**Electric starter button    Headlight switch**

Remove the handlebar lock nut and take out the bolt.  
Remove the handlebar.



### INSTALLATION

Install the handlebar onto the steering stem and install the handlebar, lock nut and bolt.  
Tighten the bolt to the specified torque.

**Torque:** 6.0~6.5 kgf-m



Install the front and rear master cylinders and connect the brake light switch wires.



**Electric starter button    Headlight switch**

**DISASSEMBLY**

Remove two screws attaching to the right handlebar switch.



Disconnect the throttle cable from the throttle grip.  
Remove the right handlebar switch.

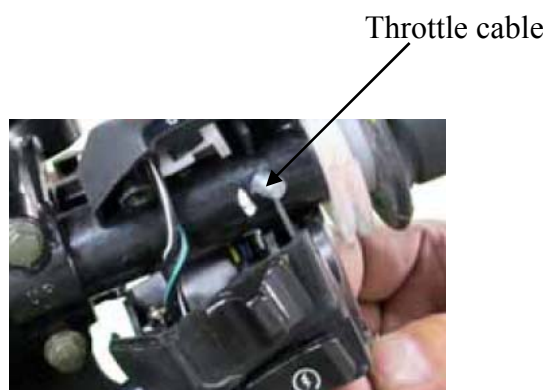

Remove two screws and then remove the left handlebar switch.



**ASSEMBLY**

Install the left handlebar switch.

\* Align the pin on the left handlebar switch with the hole on the handlebar.

Install and tighten the two screws securely.

Install the right handlebar switch.

\* Align the pin on the right handlebar switch with the hole on the handlebar.



Lubricate the throttle grip front end with grease and then connect the throttle cable to the throttle grip.

Install and tighten the two screws.

**FRONT WHEEL**

**REMOVAL**

Jack the scooter front wheel off the ground.  
Remove the bolt and then pull out the axle.  
Remove the front wheel and collar.



**AXLE RUNOUT INSPECTION**

Set the axle in V blocks and measure the runout using a dial gauge.

The actual runout is 1/2 of the total indicator reading.

**Service Limit:** 0.2 mm (0.008 in)

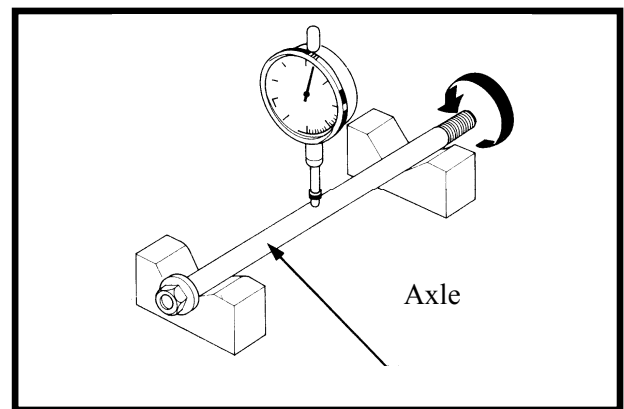

**WHEEL RIM INSPECTION**

Check the wheel rim runout.

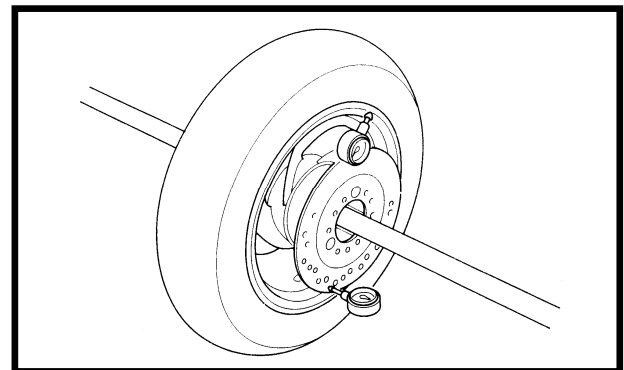

**INSTALLATION**

Apply grease to the collar, then install the collar onto the wheel.



Dust Seal

**DISASSEMBLY**

Remove the side collar and dust seal.

Turn the inner race of each bearing with your finger to see if they turn smoothly and quietly. Also check if the outer race fits tightly in the hub.

Replace the bearings if the races do not turn smoothly, quietly, or if they fit loosely in the hub.

Remove the front wheel bearing.



Remove the distance collar from wheel.

**FRONT BRAKE FLUID**

**FLUID REPLACEMENT/AIR  
BLEEDING**

- \* • A contaminated brake disc or pad reduces stopping power. Discard contaminated pads and clean a contaminated disc with a high quality brake degreasing agent.
- Do not allow foreign material to enter the system when filling the reservoir.
  - Avoid spilling brake fluid on painted, plastic or rubber parts. Place a rag over these parts whenever the system is serviced.



**BRAKE FLUID DRAINING**

Make sure that the master cylinder parallel to the ground before removing the reservoir cover.

Remove two screws.

Remove the reservoir cover, diaphragm plate and diaphragm.

Connect a bleed hose to the bleed valve.



Loosen the bleed valve and apply the brake lever.

Stop operating the brake when no more fluid flows out of the bleed valve.

**BRAKE FLUID FILLING/AIR BLEEDING**

\* Do not mix different types of fluid since they are not compatible.

Fill the master cylinder with DOT 4 to the upper level.

Connect a commercially available brake bleeder to the front caliper bleed valve.

Check the fluid level often while bleeding the brake to prevent air from being pumped into the system.

Pump the brake bleeder and loosen the front caliper bleed valve. Add fluid when the fluid level in the master cylinder is low to prevent drawing air into the system.

Repeat the above procedures until no air bubbles appear in the plastic hose.

Close the front caliper bleeding valve and operate the front brake lever.

If it's still spongy, bleeding the system again.

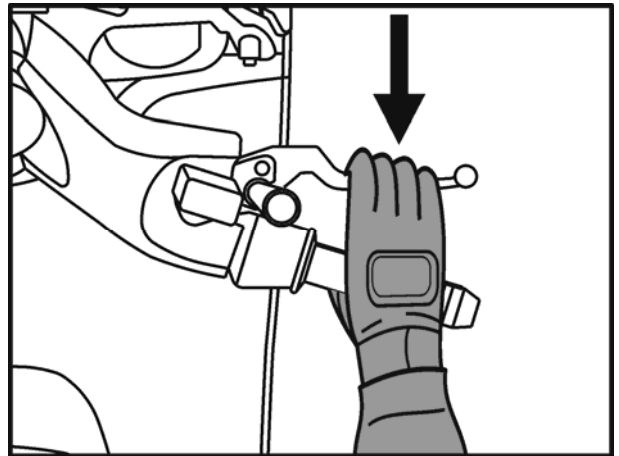

If the brake bleeder is not available, perform the following procedure.

Pump up the system pressure with the brake lever until there are no air bubbles in the fluid flowing out of the reservoir small hole and lever resistance is felt.

1. Pump the brake lever several times, then squeeze the brake lever all the way and loosen the bleed valve 1/4 turn. Wait several seconds and close the bleed valve.

\* Do not release the brake lever until the bleed valve has been closed.

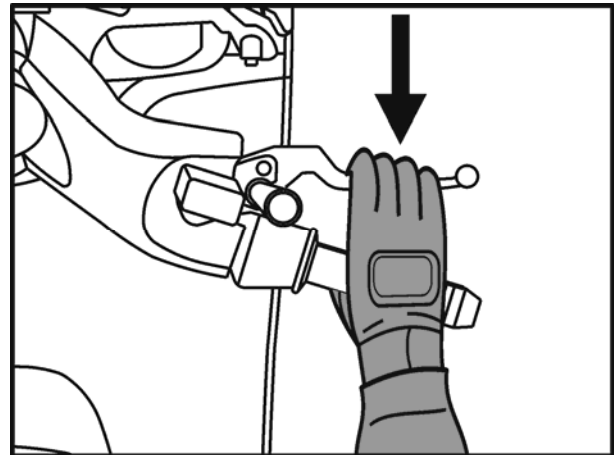

2. Release the brake lever slowly until the bleed valve has been closed. Add fluid when the fluid level in the master cylinder is low to prevent drawing air into the system.
3. Repeat the steps 1 - 2 until there are no air bubbles in the bleed hose.



After bleeding air completely, tighten the bleed valve to the specified torque.

**Torque:** 6 N-m (0.6 kgf-m, 4.3 lbf-ft)

Fill the reservoir to the casting ledge with DOT 4 to the upper level.

Install the diaphragm, set plate and reservoir cover and tighten the screws to the specified torque.

**Torque:** 2 N-m (0.2 kgf-m, 1.1 lbf-ft)

**FRONT BRAKE PAD**

**BRAKE PAD REPLACEMENT**

Remove the caliper mounting bolts, then remove the caliper.



Brake Pads

Remove the brake pads.



\* Always replace the brake pads in pairs to ensure even disc pressure.

Install new pads so that their ends rest on the pad retainer on the brake properly.



Install the front caliper onto the fork leg and then install and tighten the new two caliper mounting bolts to the specified torque.

**Torque:** 35 N-m (3.5 kgf-m)

Tighten the pad pins to the specified torque.

**Torque:** 18 N-m (1.8 kgf-m, 13 lbf-ft)



**BRAKE DISC INSPECTION**

ITEM		STANDARD	SERVICE LIMIT
Brake disc thickness	Front	5±0.1mm (0.2±0.004in)	4.0mm (0.16in)
	Rear	4±0.2mm (0.16±0.004in)	3.5mm (0.14in)



### FRONT SHOCK ABSORBER

#### REMOVAL

Remove the front cover and front fender.  
Remove the front brake caliper  
Remove the front wheel  
Remove the speed wheel sensor bolt and then remove the brake hose guide from right front shock absorber.  
Remove two mounting bolts and then remove the right/left front shock absorber.



#### INSTALLATION

Installation is in the reverse order of removal.

\* Tighten the shock absorber mounting bolt to the specified torque.

**Torque: 2.7 kgf-m (27 N-m, 19.5 lbf-ft)**

#### INSPECTION

Inspect the following items and replace if necessary.

- Front shock absorber tube bending, damage or wear
- Weak front shock absorber spring
- Damper and damper rod bending
- Oil seal damage or wear



## STEERING STEM

### REMOVAL

Remove the steering handlebar.  
Remove the front brake hose and speed wheel sensor connector from the guide.

Hold the steering stem top cone race and remove the steering stem lock nut by using the special tool.

#### Special tool:

Lock nut wrench            F00002



Lock Nut Wrench



Remove the top cone race and washer.  
Remove the steering stem.



## 12. HANDLEBAR/FRONT WHEEL/FRONT BRAKE/ FRONT SHOCK ABSORBER/STEERING STEM

Inspect the ball races, cone races and steel balls for wear or damage. Replace if necessary.

Remove the top balls.

Remove the upper ball race by using a chisel if necessary.

Ball

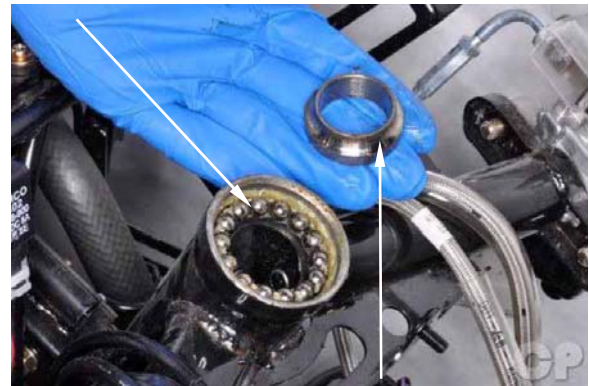

Top Ball Cone Race

Remove the bottom balls.

Remove the bottom ball race.



Remove the bottom cone race by using a chisel if necessary.

\* Be careful not to damage the steering stem.



Install with reverse operation.

**REAR WHEEL/REAR BRAKE/REAR SHOCK ABSORBER**

SERVICE INFORMATION ..... 13-2  
TROUBLESHOOTING ..... 13-2  
REAR WHEEL ..... 13-3  
REAR BRAKE ..... 13-4  
REAR SHOCK ABSORBER ..... 13-7

# 13. REAR WHEEL/REAR BRAKE/REAR SHOCK ABSORBER

---

G-DINK 50

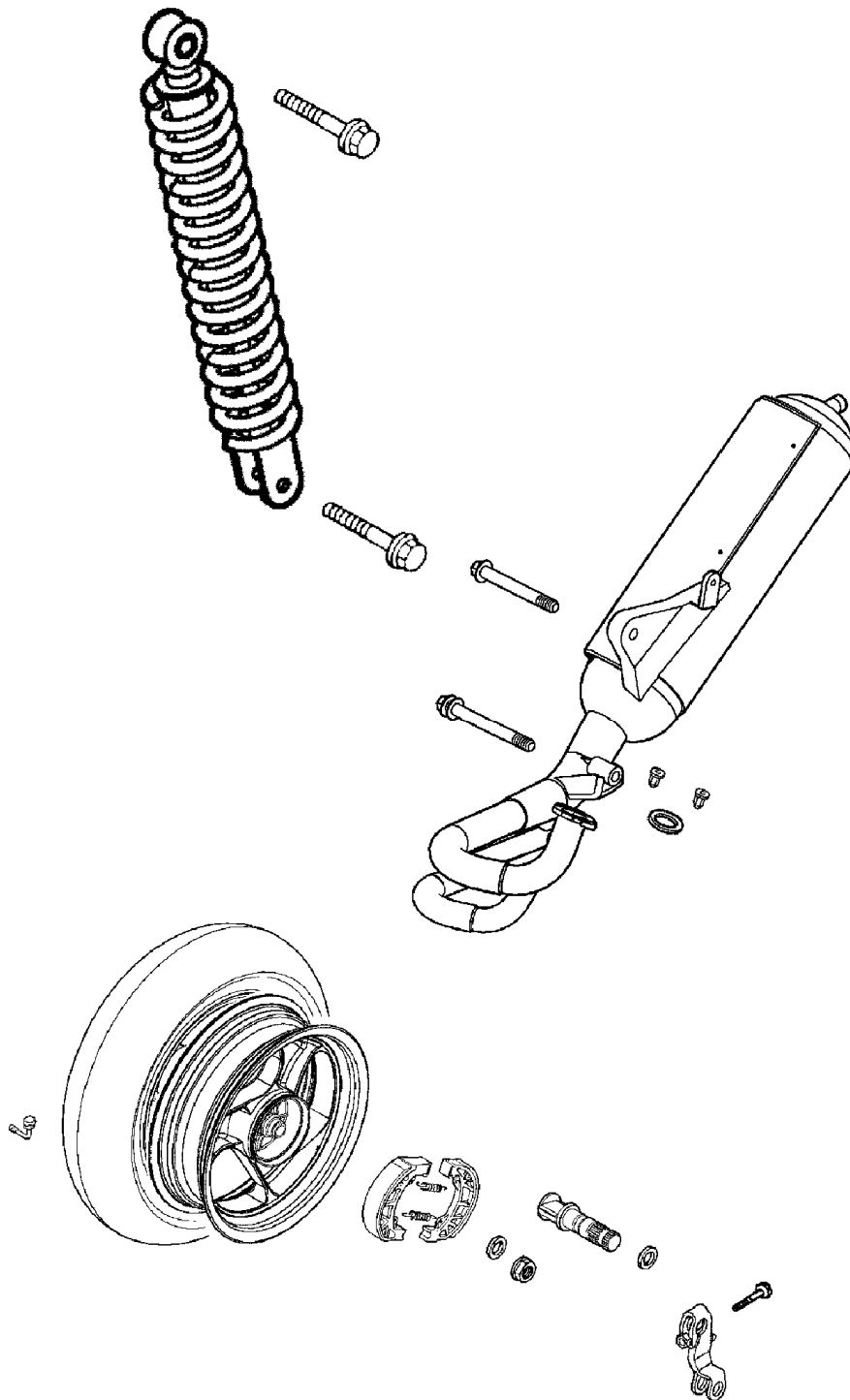

## SERVICE INFORMATION

## SPECIFICATIONS

## TORQUE VALUES

Rear axle nut	11.0~13.0kg-m
Rear shock absorber upper mount bolt	3.5~4.5kg-m
Rear shock absorber lower mount bolt	2.4~3.0kg-m

## SPECIAL TOOL

Rear shock absorber remover  
Rear shock absorber compressor

## TROUBLESHOOTING

### Rear wheel wobbling

- Bent rim
- Faulty tire
- Axle not tightened properly

### Soft rear shock absorber

- Weak shock absorber spring

### Poor brake performance

- Brake not adjusted properly
- Contaminated brake linings
- Worn brake linings
- Worn brake shoes at cam contacting area
- Worn brake cam
- Improper engagement between brake arm and wear indicator plate

# 13. REAR WHEEL/REAR BRAKE/REAR SHOCK ABSORBER

G-DINK 50

## REAR WHEEL

### REMOVAL

Remove the two exhaust muffler joint lock nuts.  
Remove the two exhaust muffler lock bolts.  
Remove the exhaust muffler.  
Remove the rear axle nut to remove the rear wheel.

Rear Axle Nut



### INSPECTION

Measure the rear wheel rim runout.

#### Service Limits:

Radial : 2.0mm replace if over

Axial : 2.0mm replace if over

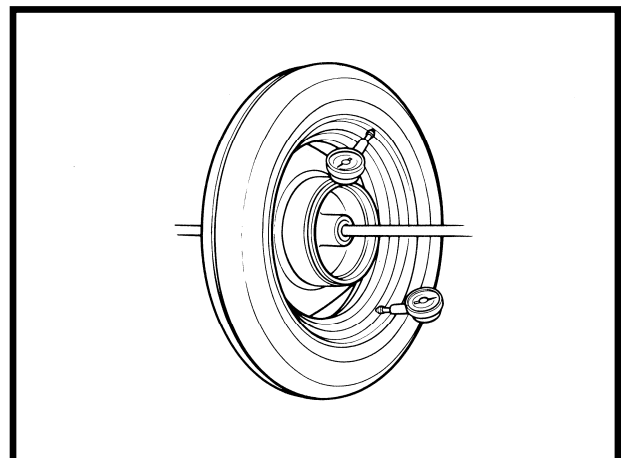

### INSTALLATION

Install the rear wheel and apply SAE30# engine oil to the axle threads. Then, tighten the rear axle nut.

#### Torque values:

Rear axle nut: 11.0~13.0kg-m

Rear Axle Nut



# 13. REAR WHEEL/REAR BRAKE/REAR SHOCK ABSORBER

G-DINK 50

## REAR BRAKE

Remove the rear wheel.  
Inspect the rear brake drum.  
Measure the rear brake drum I.D.

**Service Limit:** 95.5mm replace if over



## BRAKE LINING INSPECTION

Measure the brake lining thickness.  
**Service Limit:** 2.0mm replace if below

\* Keep oil or grease off the brake linings.

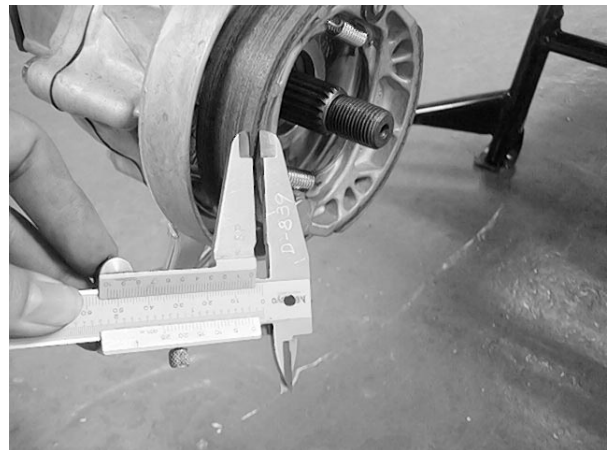

## REAR BRAKE DISASSEMBLY

Remove the rear brake adjusting nut and disconnect the rear brake cable.  
Remove the rear brake shoes.

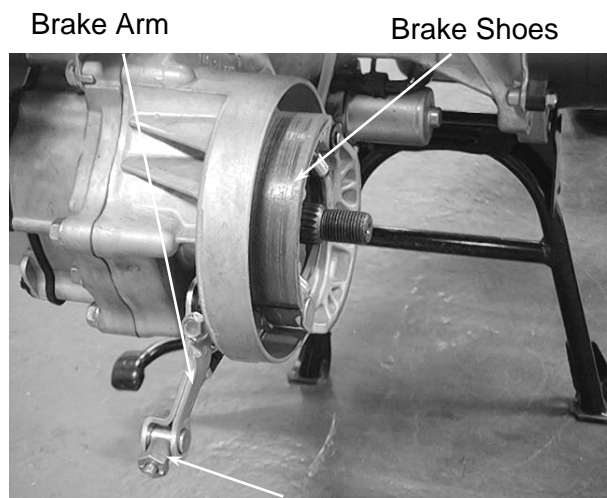

Adjusting Nut

# 13. REAR WHEEL/REAR BRAKE/REAR SHOCK ABSORBER

G-DINK 50

Remove the brake cam bolt to remove the brake arm, wear indicator plate and felt seal.

Remove the. brake arm.

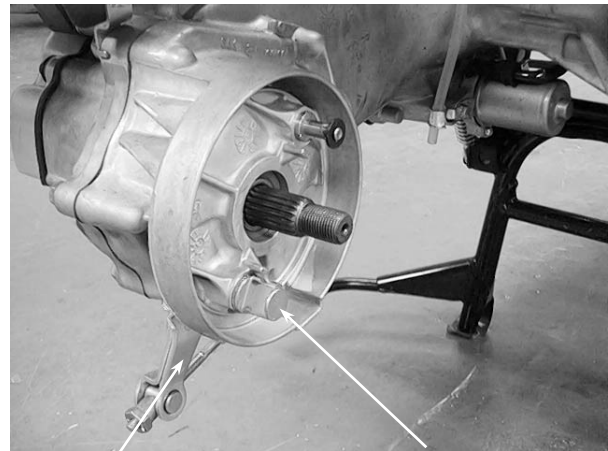

Brake Arm

Brake Cam

## REAR BRAKE ASSEMBLY

Apply grease to the anchor pin and brake shoe moving parts.

Apply grease to the brake cam and install it.

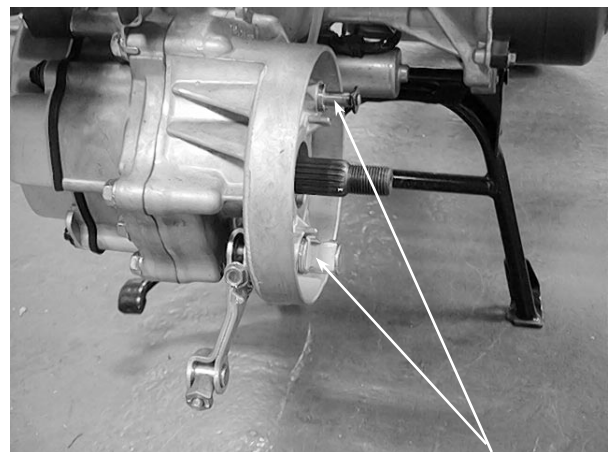

Grease

Apply engine oil to the felt seal and install it to the brake cam.

Install the wear indicator plate.

- \* 

Align the wide tooth of the wear indicator plate with the wide groove on the brake cam.
---

Install the brake arm onto the brake cam.

- \* 

Align the punch mark on the brake arm with the scribed line on the brake cam.
---

Install and tighten the brake arm bolt.

Install the brake arm return spring.

Install the brake shoes.

Wear Indicator Plate

Punch Mark



Brake Arm

# 13. REAR WHEEL/REAR BRAKE/REAR SHOCK ABSORBER

G-DINK 50

Install the brake arm pin.  
Connect the brake cable and install the adjusting nut.  
Install the rear wheel.  
Adjust the rear brake lever free play.

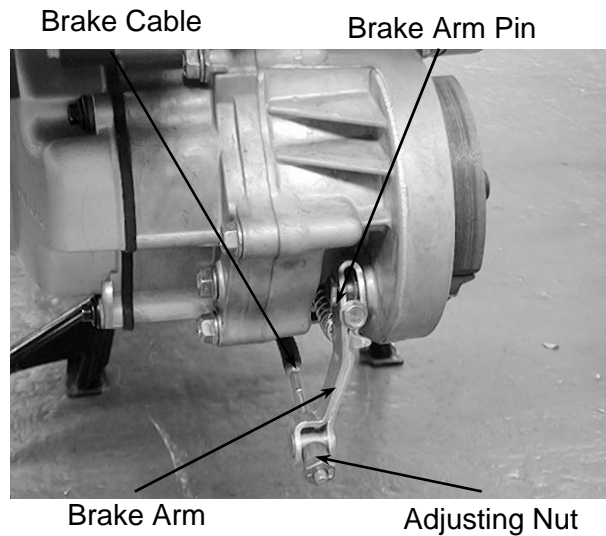

## REAR SHOCK ABSORBER

### REMOVAL

Remove the front cover.  
Remove the met-in box.  
Remove the air cleaner case.  
Remove the rear shock absorber upper and lower mount bolts to remove the rear shock absorber.

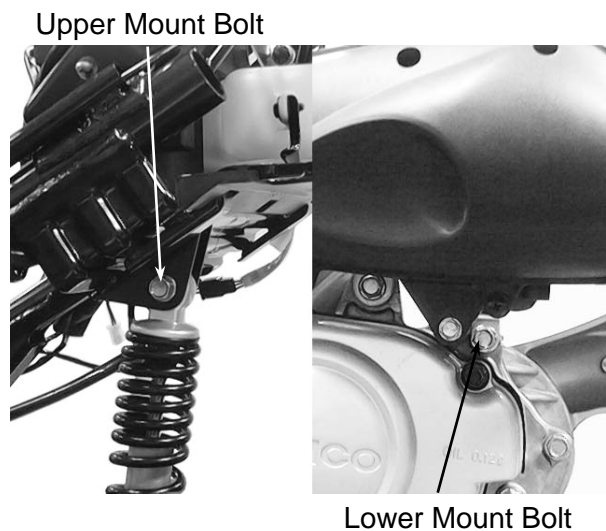

### INSTALLATION

Install the rear shock absorber.  
Install the rear shock absorber upper mount bolt and then install the lower mount bolt.

#### Torque:

**Upper Mount Bolt:** 3.5~4.5kg-m

**Lower Mount Bolt:** 2.4~3.0kg-m

Install the frame body cover.

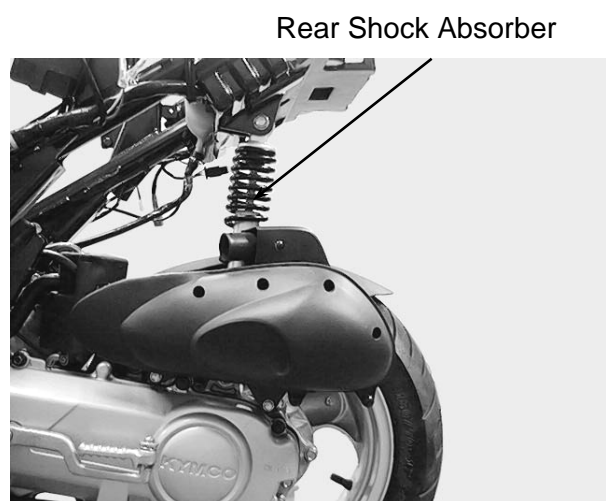

# 14. BATTERY/CHARGING SYSTEM

---

---

---

---

---

**14**

---

## BATTERY/CHARGING SYSTEM

---

CHARGING SYSTEM LAYOUT .....	14-1
CHARGING CIRCUIT .....	14-1
SERVICE INFORMATION.....	14-2
TROUBLESHOOTING.....	14-3
BATTERY CHARGING .....	14-5
CHARGING SYSTEM .....	14-5
REGULATOR/RECTIFIER .....	14-6

# 14. BATTERY/CHARGING SYSTEM

## CHARGING SYSTEM LAYOUT

BATTERY



REGULATOR/RECTIFIER

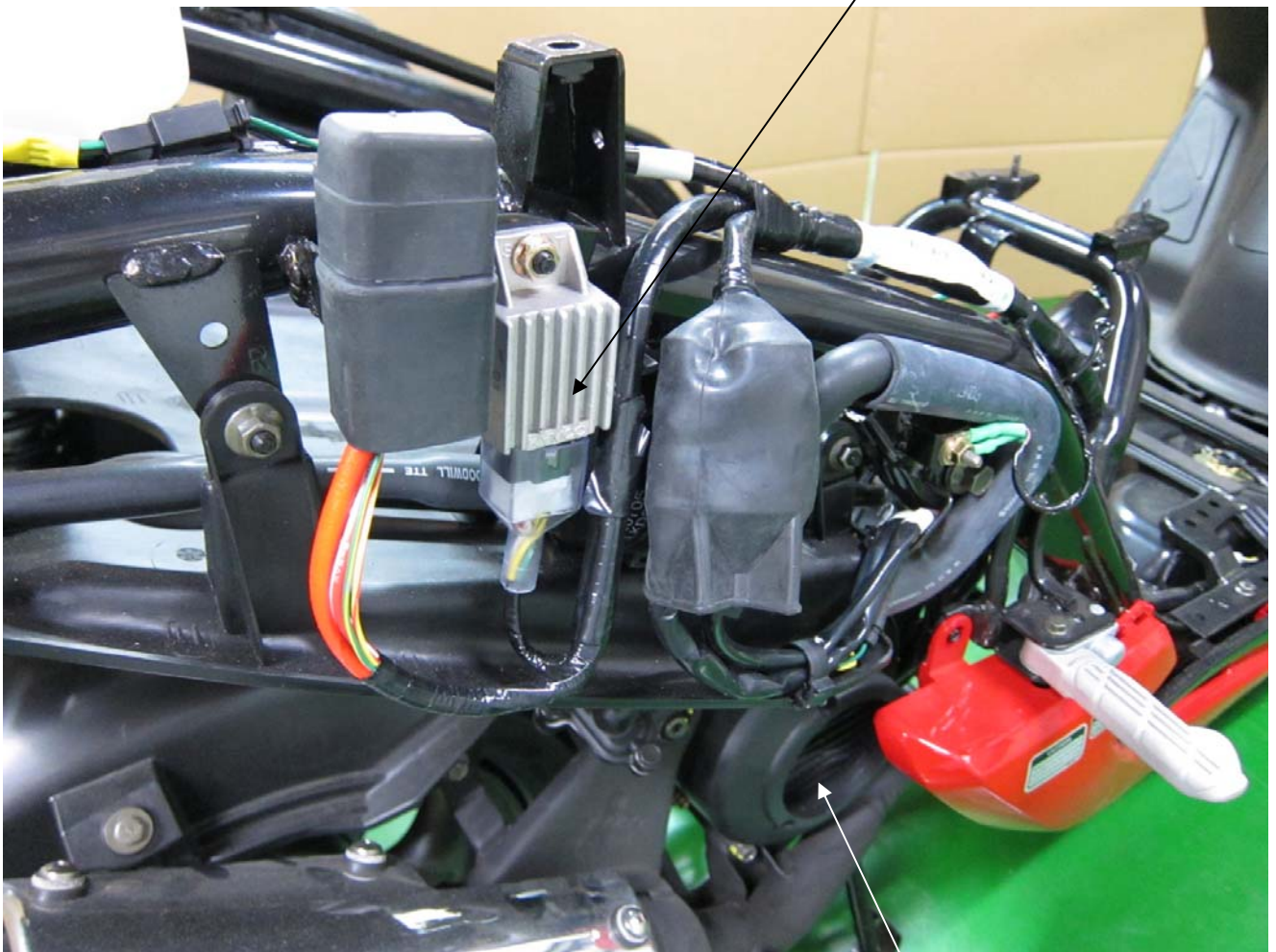

ACG

# 14. BATTERY/CHARGING SYSTEM

## SERVICE INFORMATION

### GENERAL INSTRUCTIONS

\* The battery electrolyte (sulfuric acid) is poisonous and may seriously damage the skin and eyes. Avoid contact with skin, eyes, or clothing. In case of contact, flush with water and get prompt medical attention

- The battery can be charged and discharged repeatedly. If a discharged battery is not used for a long time, its service life will be shortened. Generally, the capacity of a battery will decrease after it is used for 2~3 years. A capacity-decreased battery will resume its voltage after it is recharged but its voltage decreases suddenly and then increases when a load is added.
- When a battery is overcharged, some symptoms can be found. If there is a short circuit inside the battery, no voltage is produced on the battery terminals. If the rectifier won't operate, the voltage will become too high and shorten the battery service life.
- If a battery is not used for a long time, it will discharge by itself and should be recharged every 3 months.
- A new battery filled with electrolyte will generate voltage within a certain time and it should be recharged when the capacity is insufficient. Recharging a new battery will prolong its service life.
- Inspect the charging system according to the sequence specified in the Troubleshooting.
- Do not disconnect and soon reconnect the power of any electrical equipment because the electronic parts in the regulator/rectifier will be damaged. Turn off the ignition switch before operation.
- It is not necessary to check the MF battery electrolyte or fill with distilled water.
- Check the load of the whole charging system.
- Do not quick charge the battery. Quick charging should only be done in an emergency.
- Remove the battery from the motorcycle for charging.
- When replacing the battery, do not use a traditional battery.
- When charging, check the voltage with an electric tester.

### SPECIFICATIONS

		<b>Item</b>	<b>Standard</b>
Battery	Capacity		12V4AH
	Voltage (20°C)	Fully charged	13.2V
		Insufficient charged	< 12.3V
	Charging current		1.2A* 5~10H

# 14. BATTERY/CHARGING SYSTEM

---

## TROUBLESHOOTING

### No power

- Dead battery
- Disconnected battery cable
- Fuse burned out
- Faulty ignition switch

### Low power

- Weak battery
- Loose battery connection
- Charging system failure
- Faulty regulator/rectifier

### Intermittent power

- Loose battery cable connection
- Loose charging system connection
- Loose connection or short circuit in ignition system

### Charging system failure

- Loose, broken or shorted wire or connector
- Faulty regulator/rectifier
- Faulty A.C. generator

# 14. BATTERY/CHARGING SYSTEM

## BATTERY

### REMOVAL

The battery is in the battery box below seat.

1. Remove the seat.
2. Remove the met-in box
3. Remove 3 screws then the battery cover.
4. Pull battery out to expose the terminal leads
5. Disconnect the negative (-) terminal lead from the battery first, then disconnect the positive (+) terminal lead.
6. Remove the battery from the battery box.

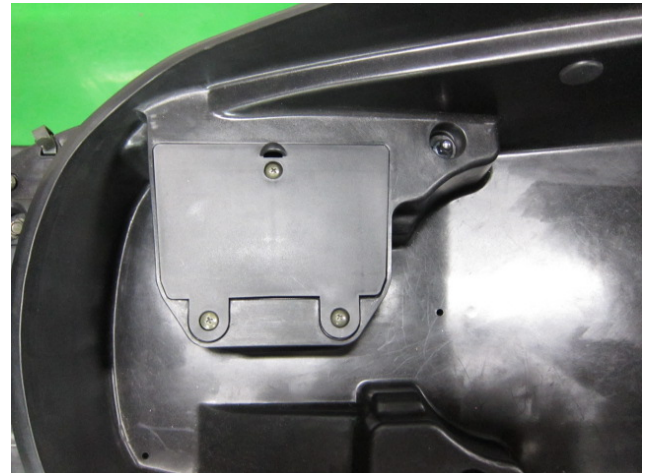

### BATTERY INSTALLATION

Install in the reverse order of the removal.

- \* When install the battery, first connect the positive (+) cable and then negative (-) cable to avoid short circuit.

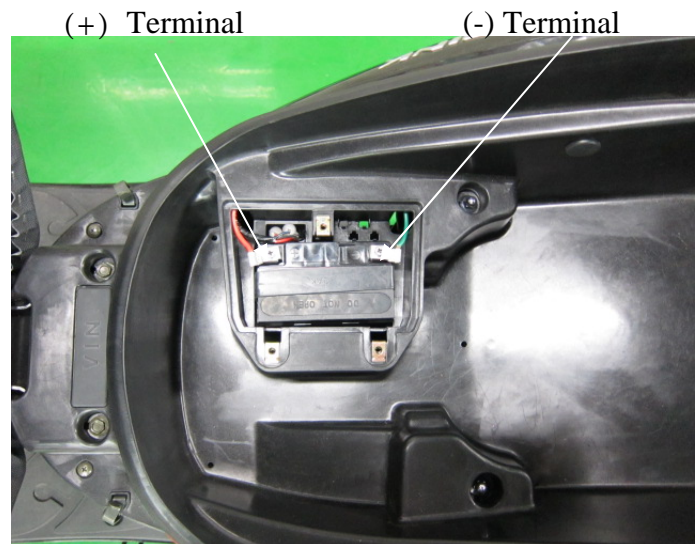

### VOLTAGE INSPECTION

Remove the battery cover.

Measure the battery voltage by using a commercially available digital multimeter.

**Voltage (20°C/68°F):**

**Fully charged: 13.0 ~ 13.2 V**

**Insufficient charged: < 12.3 V**

# 14. BATTERY/CHARGING SYSTEM

## BATTERY CHARGING

Remove the battery

Connect the charger positive (+) cable to the battery positive (+) terminal.

Connect the charger negative (-) cable to the battery negative (-) terminal.

\* Turn the power ON/OFF at the charger, not at the battery terminals.

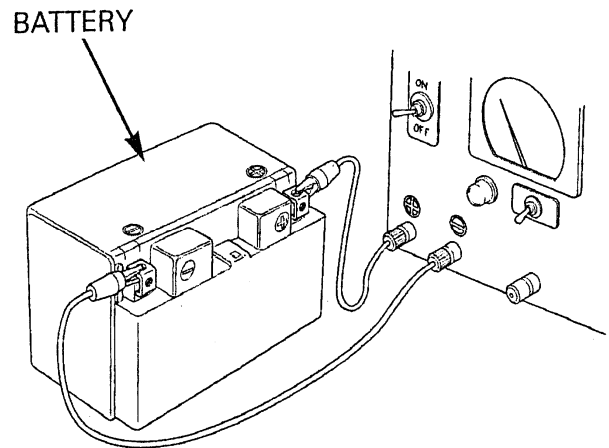

## CHARGING CURRENT:

**Standard: 1.2A / 5~10 Hours**

For battery charging, do not exceed the charging current and time specified on the battery. Using excessive current or extending the charging time may damage the battery.

## CHARGING VOLTAGE INSPECTION

Be sure that the battery is in good condition before performing this test.

\* Do not disconnect the battery or any cable in the charging system without first switching off the ignition switch. Failure to follow this precaution can damage the tester or electrical

Start the engine and warm it up to the operating temperature; stop the engine.

Connect the multimeter between the positive (+) and negative (-) terminals of the battery.

To prevent short, make absolutely certain which are the positive (+) and negative (-) terminals or cable.

With the headlight on and turned to the high beam position, restart the engine.

Measure the voltage on the multimeter when the engine runs at 5000 rpm.

## Standard:

Battery charging voltage 14 ~ 15V

(+) Terminal

(-) Terminal

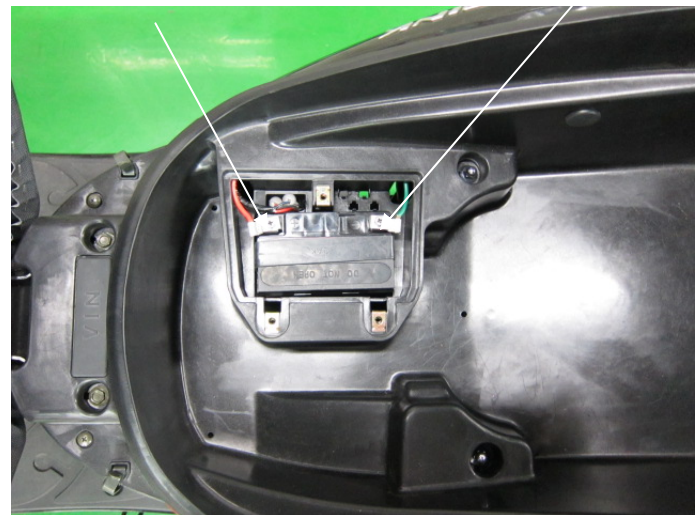

# 14. BATTERY/CHARGING SYSTEM

## RESISTOR INSPECTION

Remove the frame front cover.  
 Measure the resistance between the resistor B pink wire and ground.  
 Measure the resistance between the resistor A green/black wire and ground.

### Resistances:

- Resistor A(5W):  $5.9\Omega \pm 10\%$
- Resistor B(30W):  $15.2\Omega \pm 10\%$

\* Faulty resistor is the cause of faulty operation of the auto bystarter.

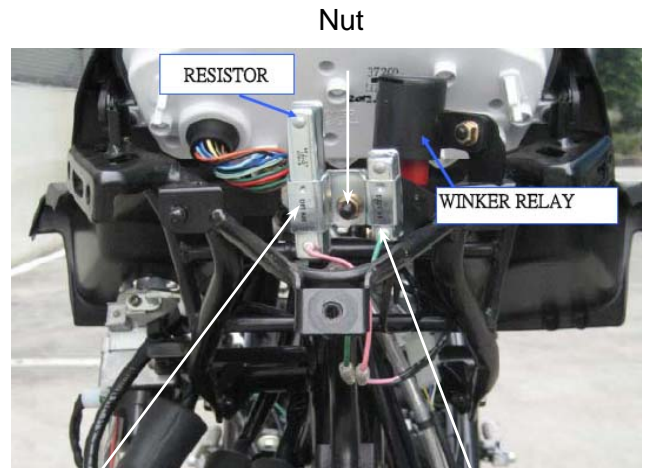

Resistor B

Resistor A

## REGULATOR/RECTIFIER INSPECTION

Disconnect the regulator/rectifier wire coupler and remove the bolt to remove the regulator/rectifier.

Measure the resistances between the terminals.  
 Replace the regulator/rectifier if the readings are not within the specifications in the table below.



Regulator/Rectifier

Probe⊕ Probe(-)	A (R)	B (W)	C (Y)	D (G)
A (R)		5-7MΩ	∞	∞
B (W)	∞		∞	∞
C (Y)	∞	∞		5-7MΩ
D (G)	∞	∞	∞	

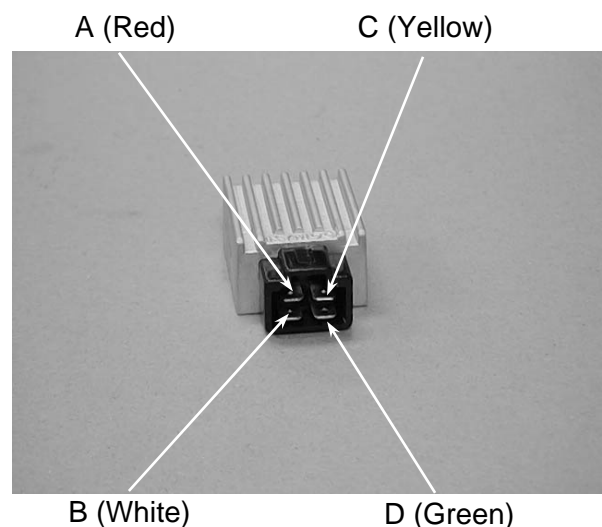

# 15. IGNITION SYSTEM

---

---

## IGNITION SYSTEM

---

IGNITION SYSTEM LAYOUT .....	15-1
IGNITION COIL INSPECTION .....	15-2
A.C. GENERATOR INSPECTION.....	15-3
CDI UNIT INSPECTION .....	15-4

# 15. IGNITION SYSTEM

## IGNITION SYSTEM LAYOUT

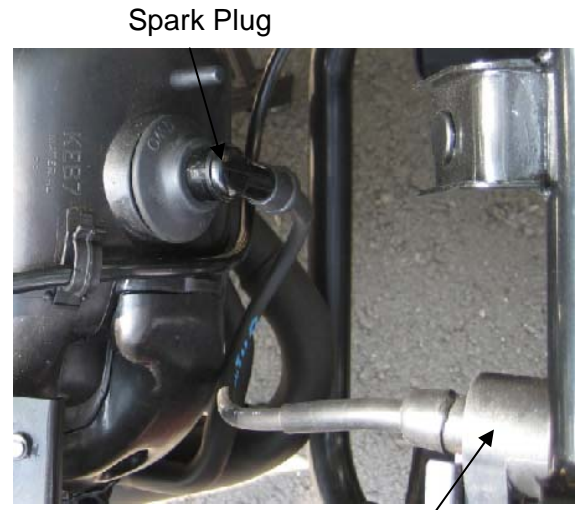
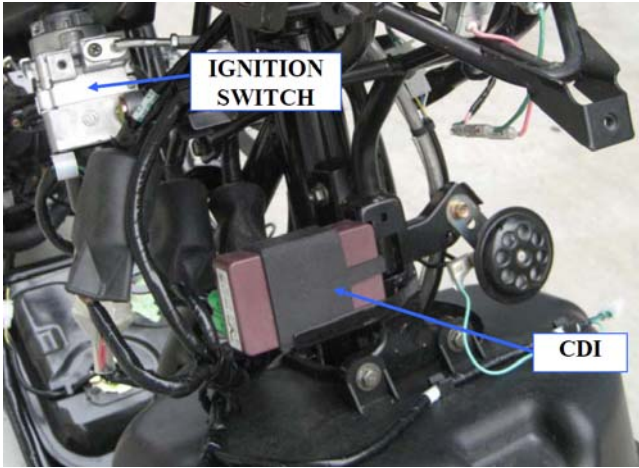

A.C. Generator

## IGNITION CIRCUIT

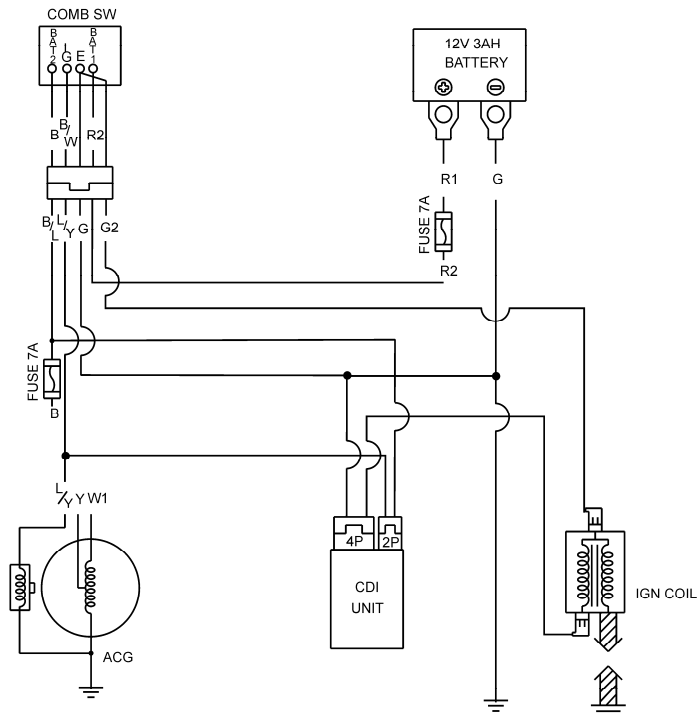

# 15. IGNITION SYSTEM

## IGNITION COIL INSPECTION

### Continuity Test

\* This test is to inspect the continuity of ignition coil.

Remove the met-in box.  
Measure the resistance between the ignition coil primary coil terminals.

**Resistance** (20°C):  $0.21\Omega \pm 10\%$

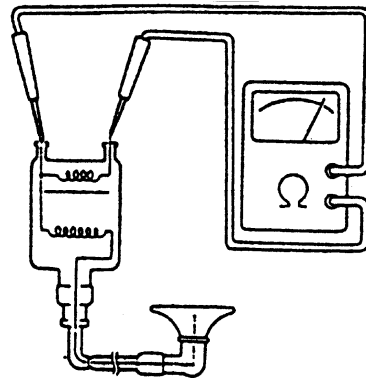

Measure the secondary coil resistance between the spark plug cap and the primary coil terminal as Figure A shown.

**Resistance** (20°C):  $3.1K\Omega \pm 10\%$

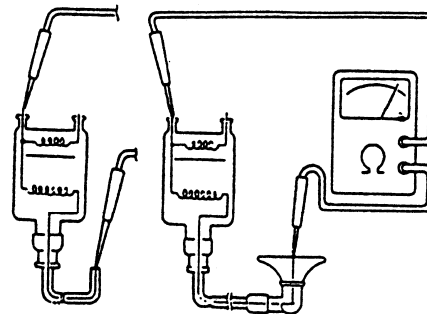

# 15. IGNITION SYSTEM

## Performance Test

Remove the ignition coil.



Ignition Coil

Inspect the ignition coil with an ignition coil tester.

\* \_\_\_\_\_

Follow the ignition coil tester manufacturer's instructions.

1. Turn the changeover switch to 12V and connect the ignition coil to the tester.
2. Turn the power switch ON and check the spark from the watch window.
  - Good : Normal and continuous spark
  - Faulty: Weak or intermittent spark

\* \_\_\_\_\_

The test is performed at both conditions that the ignition coil is cold and hot.

## A.C. GENERATOR

### Exciter Coil/Pulser Coil Inspection

\* \_\_\_\_\_

This test is performed with the stator installed in the engine.

Disconnect the A.C. generator wire connector.  
Measure the pulser coil resistance between the blue/yellow wire and ground.

**Resistance** (20°C): 80~160Ω



Blue/Yellow

# 15. IGNITION SYSTEM

## CDI UNIT INSPECTION

Remove the battery cover.  
 Disconnect the CDI coupler and remove the CDI unit.

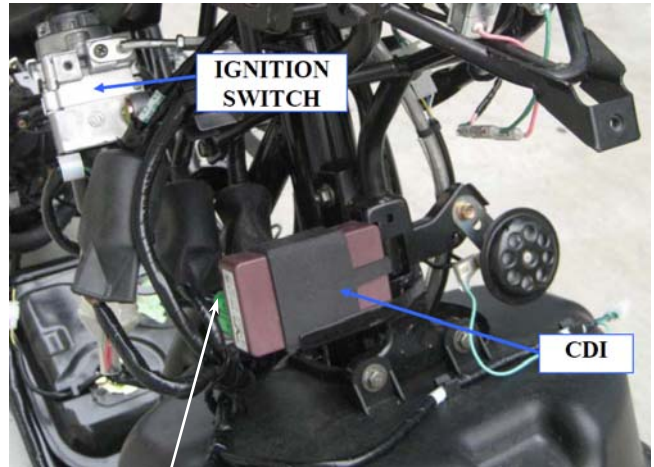

Coupler

## CDI CIRCUIT INSPECTION

Measure the resistance between the terminals.  
 Replace the CDI unit if the readings are not within the specifications in the table below.

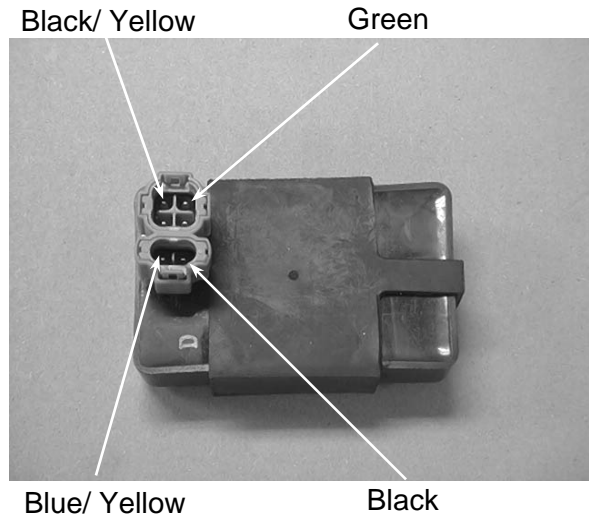

Unit:

Probe⊕ (-)Prob	Black	Blue/ Yellow	Green	Black/ Yellow
Black		4~7MΩ	4~7MΩ	2~3MΩ
Blue/ Yellow	15~20KΩ		600~900Ω	1000~1500KΩ
Green	15~20MΩ	600~900Ω		4~7MΩ
Black/ Yellow	∞	∞	∞	

# 16. STARTING SYSTEM

---

**16**

---

## STARTING SYSTEM

---

STARTING SYSTEM LAYOUT .....	16-1
STARTER RELAY INSPECTION.....	16-2
STARTER MOTOR INSPECTION .....	16-3

# 16. STARTING SYSTEM

## STARTING SYSTEM LAYOUT

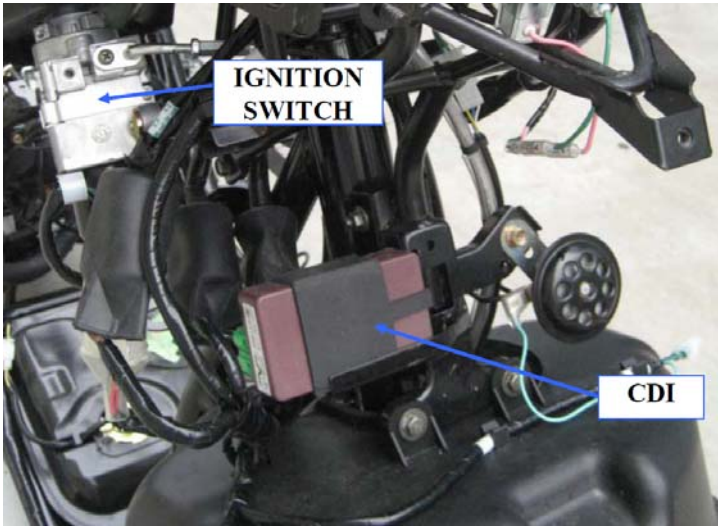

Starter Relay



## STARTING CIRCUIT

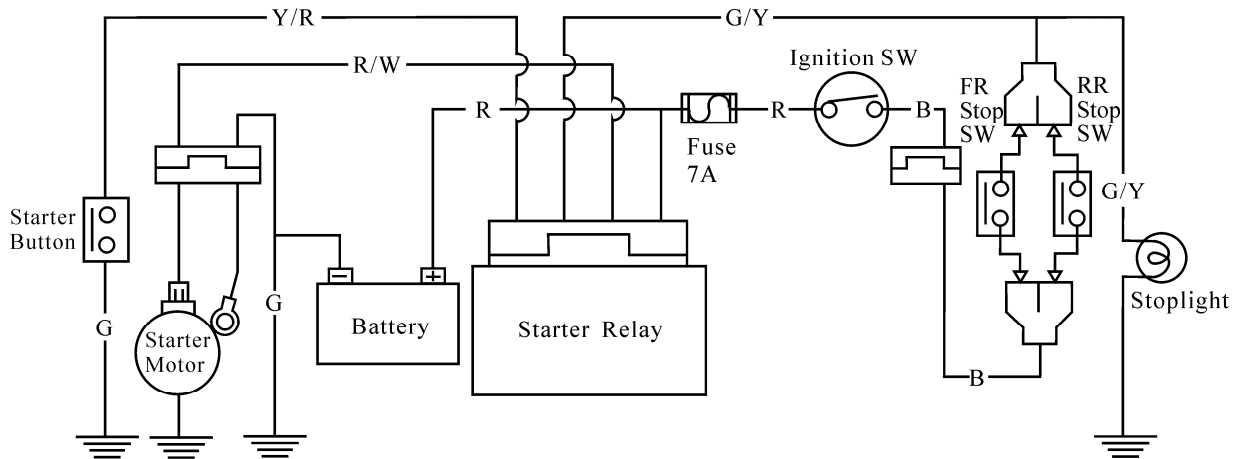

## 16. STARTING SYSTEM

---

### STARTER RELAY INSPECTION

Remove the front cover.  
Disconnect the starter relay coupler and then remove the starter relay.



Connect the starter relay green/yellow terminal to the 12V battery positive (+) terminal and the relay yellow/red terminal to the battery negative (-) terminal. Check for continuity between the starter relay red and red/white terminals. The relay is normal if there is continuity.

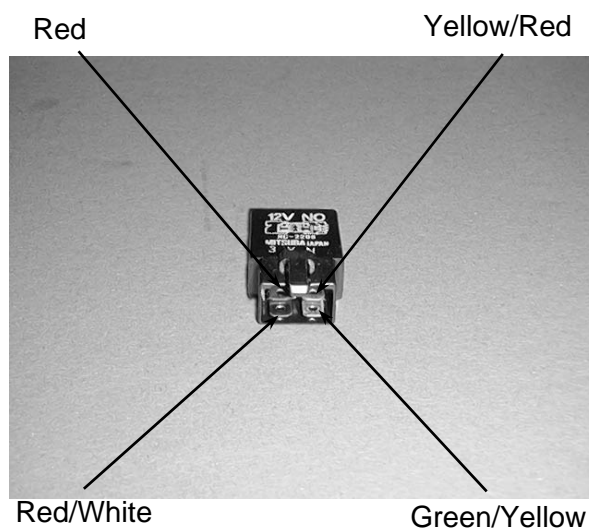

### STARTER MOTOR REMOVAL

Disconnect the starter motor cable.  
Remove the two bolts attaching the starter motor and remove the starter motor.  
The installation sequence is the reverse of removal.

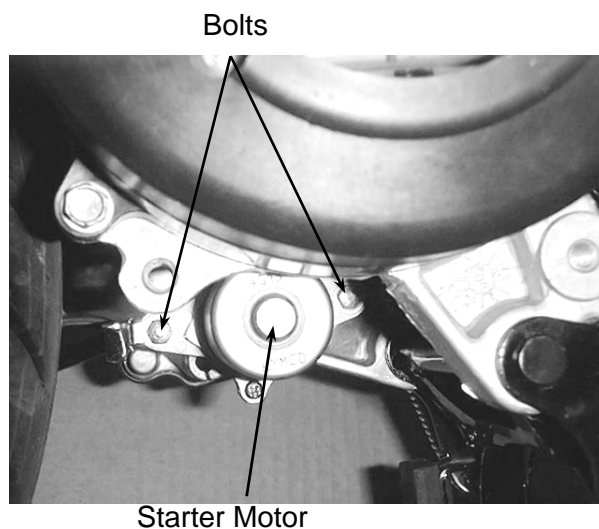

## 16. STARTING SYSTEM

### STARTER MOTOR INSPECTION

Connect a battery across the starter motor and check for its operation.

\*

1. Do not turn the starter motor for a long time.
2. This inspection should be done with a fully charged battery.

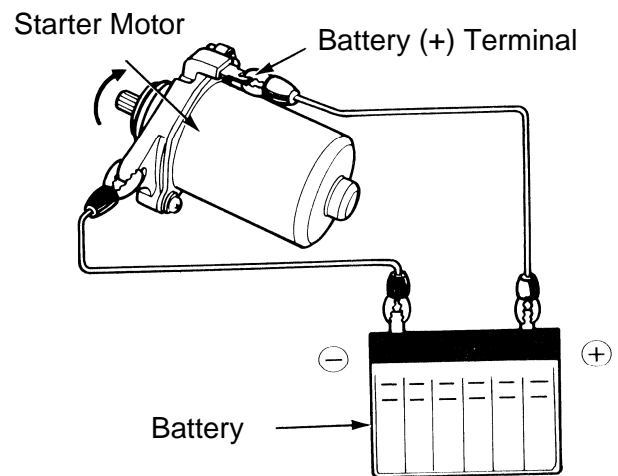

**17. LIGHTS SWITCHES**

---

---

---

---

---

---

---

---

---

**LIGHTS/METERS/SWITCHES**

---

SERVICE INFORMATION-----	17- 1
BULB REPLACEMENT -----	17- 2
HEAD LIGHT -----	17- 3
FRONT TURN SIGNAL LIGHT-----	17- 4
REAR TURN SIGNAL LIGHT-----	17- 5
IGNITION SWITCH -----	17- 6
RIGHT HANDLEBAR SWITCH INSPECTION -----	17- 7
LEFT HANDLEBAR SWITCH INSPECTION -----	17- 8
HORN -----	17- 8

# 17. LIGHTS SWITCHES

---

## SERVICE INFORMATION

### GENERAL

\* A halogen head light bulb becomes very hot while the head light is on, and remains for a while after it is turned off. Be sure to let it cool down before servicing.

- Note the following when replacing the halogen headlight bulb
  - ™ Wear clean gloves while replacing the bulb. Do not put finger prints on the headlight bulb, as they may create hot spots on the bulb and cause it to fail.
  - ™ If you touch the bulb with your bare hands, clean it with a cloth moistened with alcohol to prevent its early failure.
  - ™ Be sure to install the dust cover after replacing the bulb.
- Check the battery condition before performing any inspection that requires proper battery voltage.
- A continuity test can be made with the switches installed on the scooter.
- Route the wires and cables properly after servicing each component.

### TROUBLESHOOTING

#### Lights do not come on when ignition switch is "ON"

- Burned bulb
- Faulty switch
- Poorly connected, broken or shorted wire

#### Temperature gauge does not register correctly

- Faulty temperature gauge
- Faulty thermosensor
- Broken or shorted wire between the temperature gauge and thermosensor

#### Fuel gauge does not work or wrong show figures

- Faulty fuel gauge
- Faulty fuel unit
- Poorly connected wire between fuel gauge and fuel unit
- Fuse burned out

### SPECIFICATIONS

Fuse	10A,15A,30A
Headlight bulb	12V 60W/55W
Turn signal light bulb	12V 21W(Front) / 10W(Rear)
Stoplight/taillight	12V 21/5W

## 17. LIGHTS SWITCHES

---

### BULB REPLACEMENT

#### LICENSE LIGHT

Remove the seat assembly and luggage box.  
Remove the body covers.  
Disconnect the license bulb socket.  
Remove the bulb and replace with a new one.

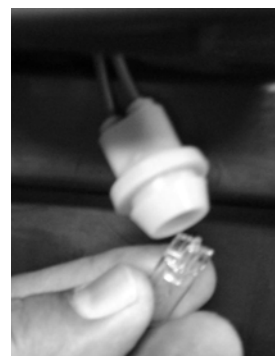
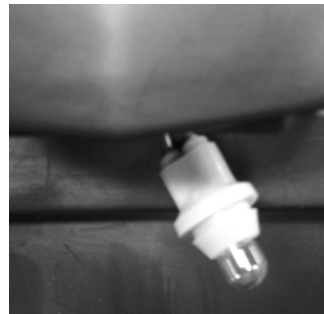

# 17. LIGHTS/METERS/SWITCHES

## HEADLIGHT

\* A halogen headlight bulb becomes hot while the headlight is ON and remains for a while after it is turned OFF. Be sure to let it cool down before servicing.

Remove the front cover  
Disconnect the headlight cover  
Disconnect the headlight connector from the headlight bulb.

Connector      Headlight Bulb

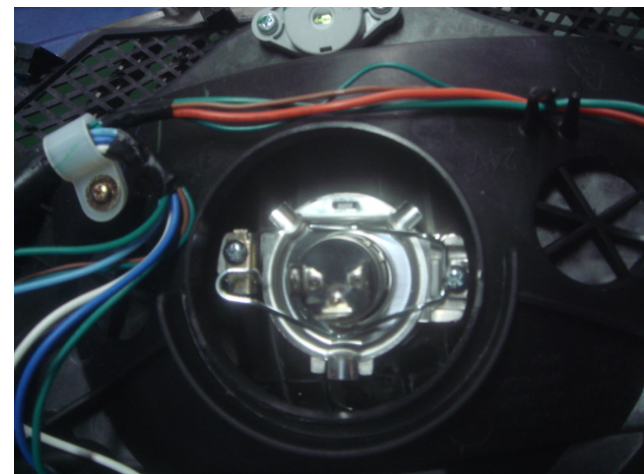
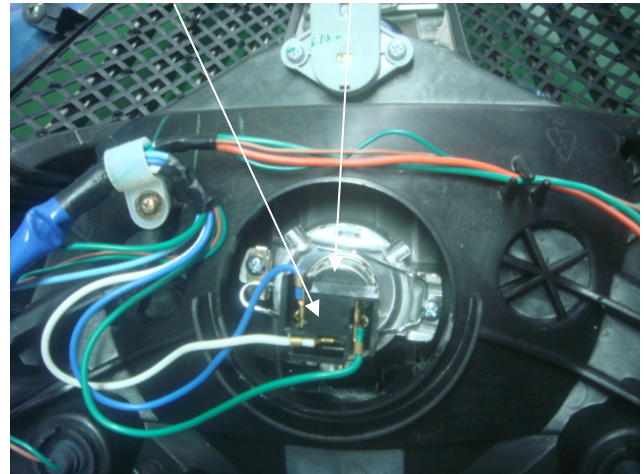

Install a new bulb into the headlight case.  
Install the headlight and connect the headlight connector

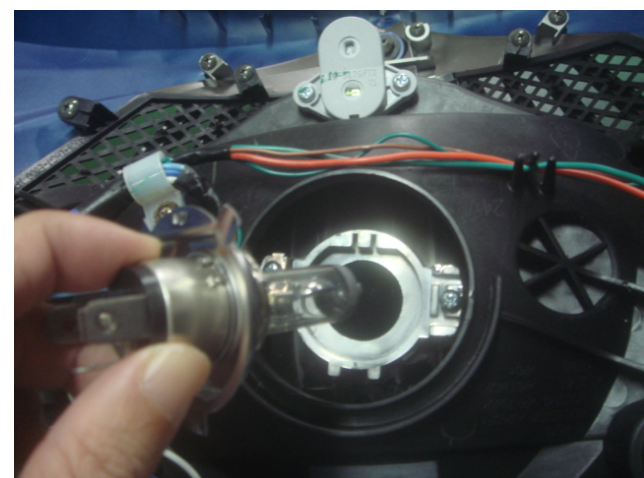

# 17. LIGHTS/METERS/SWITCHES

(1)

## FRONT TURN SIGNAL LIGHT

Remove the front cover.  
Turn the bulb socket, then remove the front turn signal light.

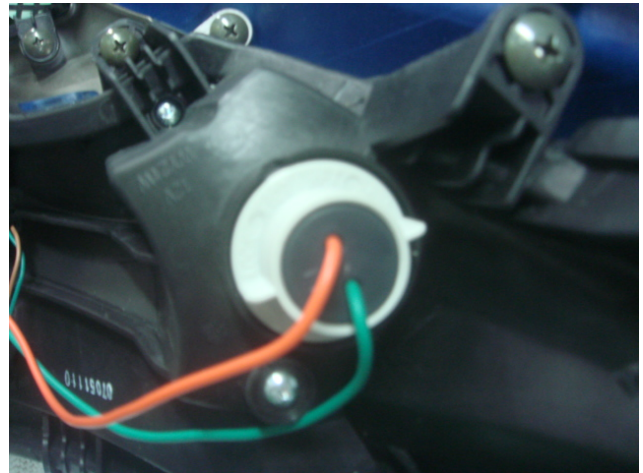

Push and turn the bulb counterclockwise to remove it, then replace with a new one.

Installation is in the reverse order of removal.

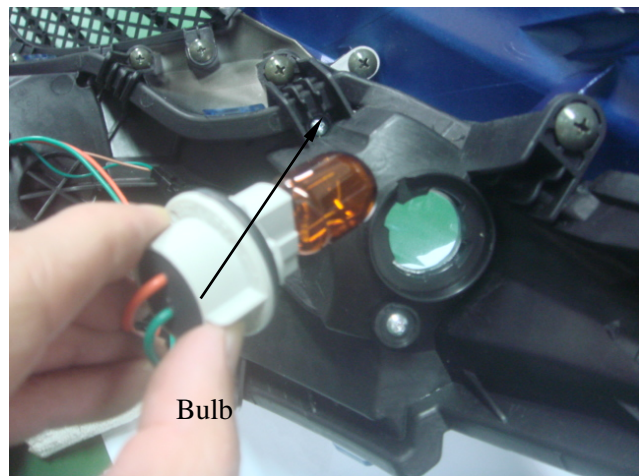

## TAILLIGHT/BRAKE LIGHT/REAR TURN SIGNAL LIGHT

Remove the seat and met-in, then remove the taillight bulb socket.

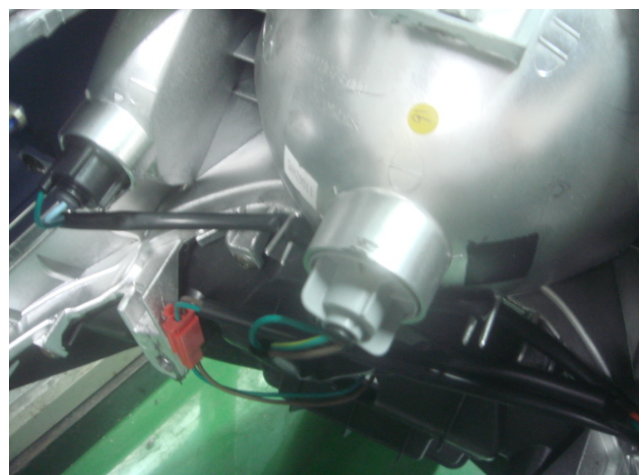

## 17. LIGHTS/METERS/SWITCHES

### REAR TURN SIGNAL LIGHT

Push and turn the bulb counterclockwise to remove it, then replace with a new one.

Installation is in the reverse order of removal.



Rear Turn Signal Light



Taillight/Brake Light

# 17. LIGHTS/METERS/SWITCHES

## BRAKE LIGHT SWITCH

Remove the upper handlebar cover.  
 Disconnect front or rear brake light switch connectors and check for continuity between the switch terminals.  
 There should be continuity with the front or rear brake lever squeezed, and there should be no continuity with the front or rear brake lever is released.



Brake Light Switch

## IGNITION SWITCH

### INSPECTION

Remove the front cover.  
 Disconnect the ignition switch connector and check the ignition switch for continuity at the switch side connector terminals.  
 Continuity should exist between the color code wires as follows:

COMB SW

	BAT2	IG	E	BAT1	HA
LOCK		○—○			
OFF		○—○		○—○	
ON	○—			○—○	
COLOR	B	B/W	G	R	B/L



# 17. LIGHTS/METERS/SWITCHES

## RIGHT HANDLEBAR SWITCH

### INSPECTION

Remove the front cover

Disconnect the right handlebar switch connector and check for continuity at switch side connector terminals.

Continuity should exist between the color code wires as follows:



Lighting Switch

Starter Switch

LIGHTING SW

	BAT3	PO	TL	HL
•				
(N)				
P	○	○	○	
(N)	○	○	○	○
H	○		○	○
COLOR	BR/L	BR/W	BR	W/L

STARTER SW

	E	ST
FREE		
PUSH	○	○
COLOR	G	Y/R

# 17. LIGHTS/METERS/SWITCHES

## LEFT HANDLEBAR SWITCH

### INSPECTION

Disconnect the left handlebar switch connector and check for continuity at switch side connector terminals.

Continuity should exist between the color code wires as follows:

WINKER SW

	WR	R	L
R	○	○	
N			
L	○		○
COLOR	GR	SB	O

HORN SW

	BAT6	HO
FREE		
PUSH	○	○
COLOR	BR/L	LG

DIMMER SW

	HL	HI	LO
LO	○		○
(N)	○	○	○
HI	○	○	
COLOR	W/L	L	W

PASSING SW

	BAT4	HI
FREE		
PUSH	○	○
COLOR	BR/L	<b>L</b>

## HORN

### INSPECTION

Remove the front cover.

Disconnect the horn connectors from the horn.

Connect a 12 V battery to the horn terminals.

The horn is normal if it sounds when the 12 V battery is connected across the horn terminals.

# 17. LIGHTS/METERS/SWITCHES

Dimmer Switch

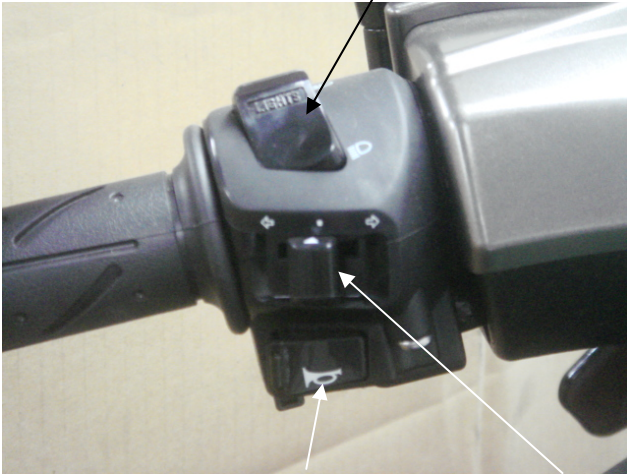

Horn Switch

Turn Signal light Switch

Passing Switch

