

---

**By KWANG YANG Motor Co., Ltd.  
First Edition, Oct 2003  
All rights reserved. Any reproduction or  
unauthorized use without the written permission of  
KWANG YANG Motor Co., Ltd.  
is expressly prohibited.  
4121-LBD3/4-S00**

---

---

# PREFACE

This Service Manual describes the technical features and servicing procedures for the KYMCO *Mongoose/KXR 90/50*.

Section 1 contains the precautions for all operations stated in this manual. Read them carefully before starting any operation.

Section 2 is the removal/installation procedures for the frame covers which are subject to higher removal/installation frequency during maintenance and servicing operations.

Section 3 describes the inspection/adjustment procedures, safety rules and service information for each part, starting from periodic maintenance.

Sections 4 through 17 give instructions for disassembly, assembly and inspection of engine, chassis frame and electrical equipment.

Most sections start with an assembly or system illustration and troubleshooting for the section. The subsequent pages give detailed procedures for the section.

The information and contents included in this manual may be different from the motorcycle in case specifications are changed.
---

## TABLE OF CONTENTS

ENGINE	GENERAL INFORMATION	1
	FRAME COVERS/EXHAUST MUFFLER	2
	INSPECTION/ADJUSTMENT	3
	LUBRICATION SYSTEM	4
	FUEL SYSTEM	5
	ENGINE REMOVAL	6
	CYLINDER HEAD/VALVES	7
	CYLINDER/PISTON	8
	DRIVE AND DRIVEN PULLEYS	9
	FINAL REDUCTION/TRANSMISSION SYSTEM	10
	CRANKCASE/CRANKSHAFT	11
CHASSIS	FRONT WHEEL/FRONT BRAKE/FRONT SUSPENSION/STEERING SYSTEM	12
	REAR WHEEL /SWING ARM/HYDRAULIC BRAKE	13
ELECTRICAL EQUIPMENT	BATTERY/CHARGING SYSTEM/A.C. GENERATOR	14
	IGNITION SYSTEM	15
	STARTING SYSTEM	16
	BULBS REMOVAL/INSTRUMENT/HORN	17

**KWANG YANG MOTOR CO., LTD.**  
**OVERSEAS SALES DEPARTMENT**  
**OVERSEAS SERVICE SECTION**

---

---

---

---

---

---

---

---

---

**GENERAL INFORMATION**

---

SERIAL NUMBER-----	1- 1
SPECIFICATIONS-----	1- 2
SERVICE PRECAUTIONS-----	1- 4
TORQUE VALUES-----	1-12
SPECIAL TOOLS-----	1-14
LUBRICATION POINTS-----	1-15
CABLE & HARNESS ROUTING-----	1-18
WIRING DIAGRAM-----	1-21
TROUBLESHOOTING-----	1-25

# 1. GENERAL INFORMATION

## SERIAL NUMBER

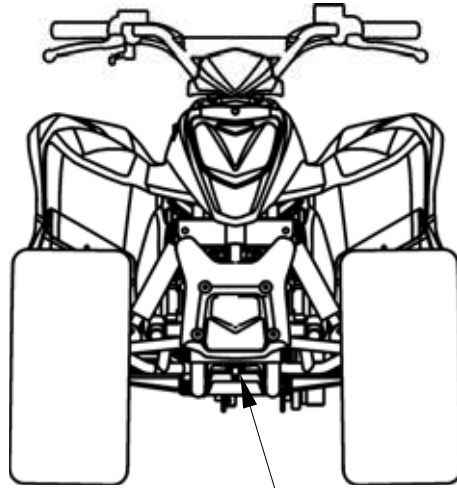

Location of Frame Serial Number

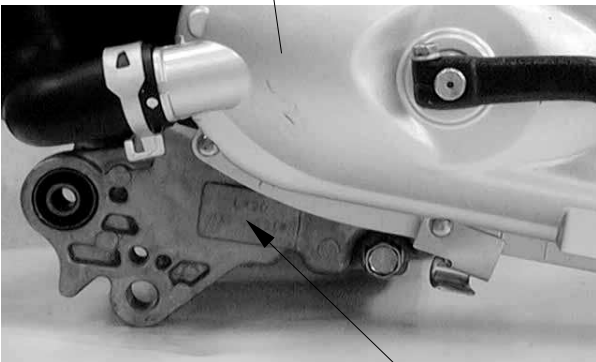
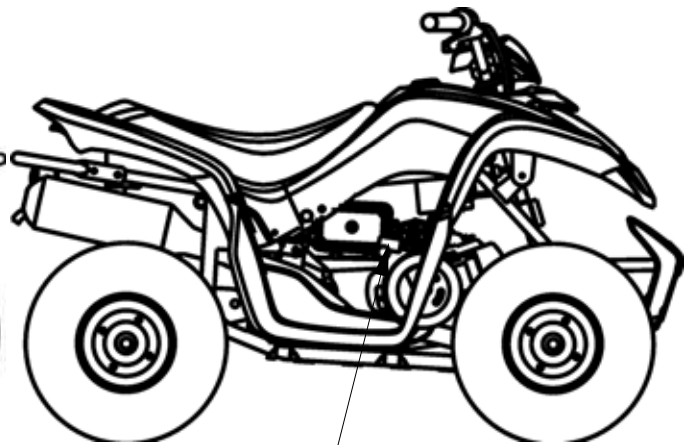
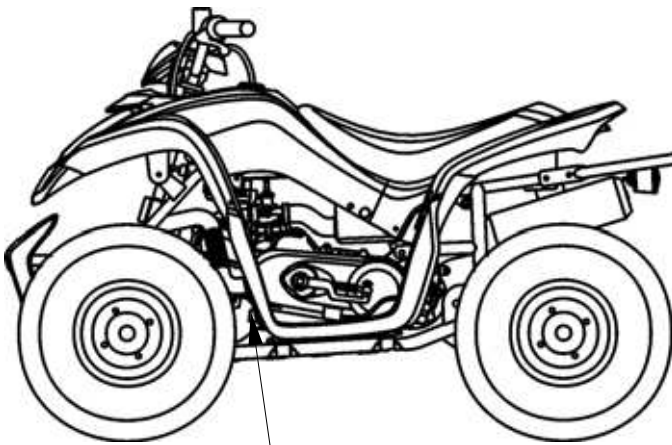

Location of Engine Serial Number



Location of Engine Serial Number

# 1. GENERAL INFORMATION

## SPECIFICATIONS

### (Mongoose/KXR 90)

Name & Model No.		LA20AB		
Motorcycle Name & Type		Mongoose/KXR 90		
Overall length (mm)		1430		
Overall width (mm)		905		
Overall height (mm)		910		
Wheel base (mm)		965		
Engine type		O.H.C.		
Displacement (cc)		89.9		
Fuel Used		92# nonleaded gasoline		
Net weight (kg)	Front wheel	58		
	Rear wheel	56.5		
	Total	114.5		
Gross weight(kg)	Front wheel	61.5		
	Rear wheel	58.5		
	Total	120		
Tires	Front wheel	18*7-8		
	Rear wheel	18*9-8		
Ground clearance (mm)		104		
Breaking distance (m)(ANSI)		20.6 below		
Engine	Starting system		Motor & Kick starter	
	Type		Gasoline, 4-stroke	
	Cylinder arrangement		Single cylinder	
	Combustion chamber type		Semi-sphere	
	Valve arrangement		O.H.C., chain drive	
	Bore x stroke (mm)		47X51.8	
	Compression ratio		10.0:1	
	Compression pressure (kg/cm <sup>2</sup> )		16.0	
	Max. output (ps/rpm)		6.3/6500	
	Max. torque (kg m/rpm)		0.7/5500	
	Port timing	Intake (1mm)	Open	2°
			Close	26°
		Exhaust (1mm)	Open	44°
			Close	-17°
	Valve clearance (cold) (mm)	Intake	0.1	
		Exhaust	0.1	
	Idle speed (rpm)		1700rpm	
	Lubrication System	Lubrication type		Forced pressure & Wet sump
		Oil pump type		Inner/outer rotor type
		Oil filter type		Full-flow filtration
		Oil capacity		0.8 liter
		Oil exchanging capacity		0.7 liter
	Cooling Type		Air cooling	

Fuel System	Air cleaner type & No		Sponge	
	Fuel capacity		5.5 liters	
	Carburetor	Type	PB	
		Main jet No.	#100	
		Venturi dia.(mm)	φ14	
Throttle type		PISTON		
Electrical Equipment System	Ignition System	Type	CDI	
		Ignition timing	28°BTDC/4000rpm	
		Contact breaker	Non-contact point type	
		Spark plug	NGK C7HSA	
	Spark plug gap	0.6~0.7mm		
Battery	Capacity	12V4AH		
Power Drive System	Clutch	Type	CVT	
		Type	Helical gear	
	Transmission Gear	Operation	Automatic centrifugal Type	
		Type	V-Belt	
	Reduction Gear	Primary reduction	0.8~2.5	
Final reduction		9.255		
Moving Device	FR/RR tire rolling circumference(mm)		1436/1436	
	Tire pressure (kg/cm <sup>2</sup> )	Front	0.25	
		Rear	0.25	
	Turning angle	Left	35°	
Right		35°		
Brake system type	Rear	Disk brake		
	Front	Drum brake		
Damping Device	Suspension type	Front	Swing axle	
		Rear	Swing arm	
Frame type		Steel tube frame		

# 1. GENERAL INFORMATION

## SPECIFICATIONS (Mongoose/KXR50)

Name & Model No.		LA10BA		
Motorcycle Name & Type		Mongoose/KXR 50		
Overall length (mm)		1385		
Overall width (mm)		875		
Overall height (mm)		890		
Wheel base (mm)		900		
Engine type		2-stroke.		
Displacement (cc)		49.4		
Fuel Used		92# nonleaded gasoline		
Net weight (kg)	Front wheel	49.6		
	Rear wheel	50.7		
	Total	100.3		
Gross weight(kg)	Front wheel	54.6		
	Rear wheel	55.7		
	Total	110.3		
Tires	Front wheel	16*8-7		
	Rear wheel	16*8-7		
Ground clearance (mm)		72		
Breaking distance (m)(ANSI)		20.6 below		
Engine	Starting system		Motor & Kick starter	
	Type		Gasoline, 2-stroke	
	Cylinder arrangement		Single cylinder	
	Combustion chamber type		Semi-sphere	
	Valve arrangement		Reed valve & piston	
	Bore x stroke (mm)		39X41.4	
	Compression ratio		7.2:1	
	Compression pressure (kg/cm <sup>2</sup> )		12.0	
	Max. output (ps/rpm)		4.6/6000	
	Max. torque (kg m/rpm)		0.55/5500	
	Port timing	Intake (1mm)	Open	Automatic controlled
			Close	Automatic controlled
		Exhaust (1mm)	Open	—
			Close	—
	Valve clearance (cold) (mm)	Intake	—	
		Exhaust	—	
	Idle speed (rpm)		2000rpm	
	Lubrication type		Separate type	
	Oil pump type		Plunger type	
	Oil filter type		Full-flow filtration	
	Cooling Type		Air cooling	

Fuel System	Air cleaner type & No		Sponge	
	Fuel capacity		5.5 liters	
	Carburetor	Type	PB	
		Main jet No.	82	
Venturi dia.(mm)		φ14		
Throttle type		PISTON		
Electrical Equipment	Ignition System	Type	CDI	
		Ignition timing	15°BTDC/1700rpm	
		Contact breaker	Non-contact point type	
		Spark plug	NGK BR8HAS	
	Spark plug gap	0.6~0.7mm		
Battery	Capacity	12V4AH		
Power Drive System	Clutch	Type	CVT	
		Transmission Gear	Type	Helical gear
	Reduction Gear	Operation	Automatic centrifugal Type	
		Type	V-Belt	
Moving Device	Primary reduction	0.895~3.113		
		Final reduction	11.05	
	FR/RR tire rolling circumference(mm)		1247/1247	
	Tire pressure (kg/cm <sup>2</sup> )	Front	0.25	
Rear		0.25		
Turning angle	Left	35°		
	Right	35°		
Brake system type		Rear	Drum brake	
		Front	Drum brake	
Damping Device	Suspension type	Front	Swing axle	
		Rear	Swing arm	
Frame type		Steel tube frame		

## SERVICE PRECAUTIONS

- Make sure to install new gaskets, O-rings, circlips, cotter pins, etc. when reassembling.

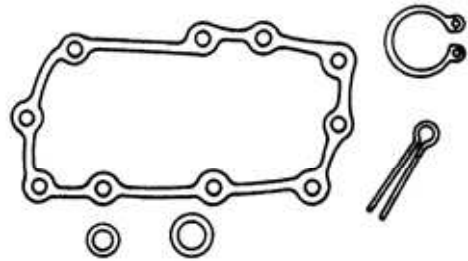

- When tightening bolts or nuts, begin with larger-diameter to smaller ones at several times, and tighten to the specified torque diagonally.

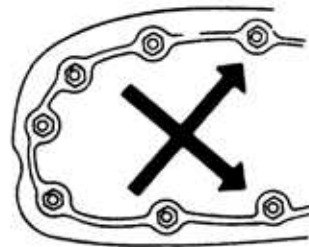

- Use genuine parts and lubricants.

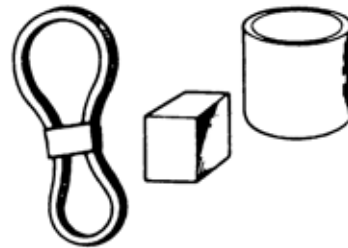

- When servicing the motorcycle, be sure to use special tools for removal and installation.



- After disassembly, clean removed parts. Lubricate sliding surfaces with engine oil before reassembly.

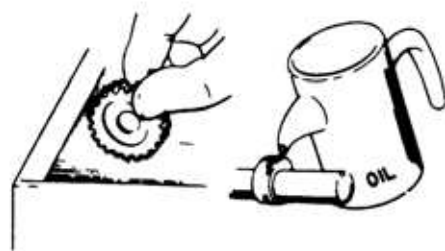

- Apply or add designated greases and lubricants to the specified lubrication points.

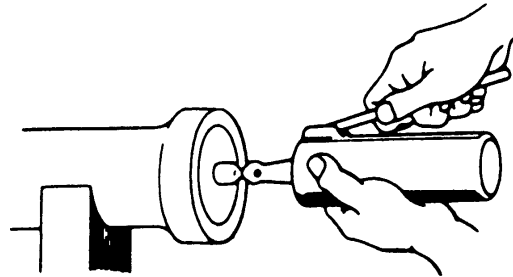

- After reassembly, check all parts for proper tightening and operation.

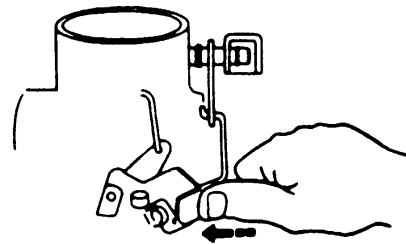

- When two persons work together, pay attention to the mutual working safety.

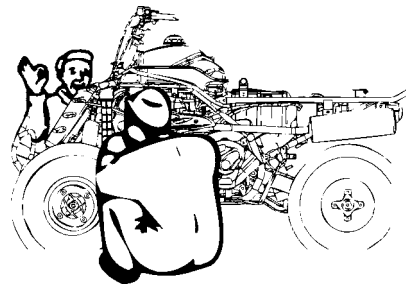

- Disconnect the battery negative (-) terminal before operation.
- When using a spanner or other tools, make sure not to damage the motorcycle surface.

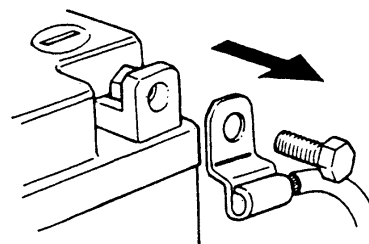

- After operation, check all connecting points, fasteners, and lines for proper connection and installation.
- When connecting the battery, the positive (+) terminal must be connected first.
- After connection, apply grease to the battery terminals.
- Terminal caps shall be installed securely.

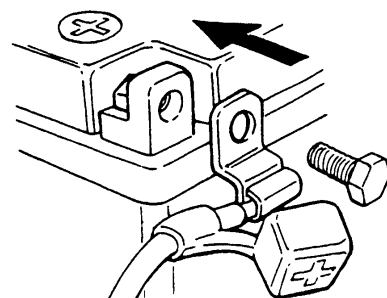



# 1. GENERAL INFORMATION

- If the fuse is burned out, find the cause and repair it. Replace it with a new one according to the specified capacity.

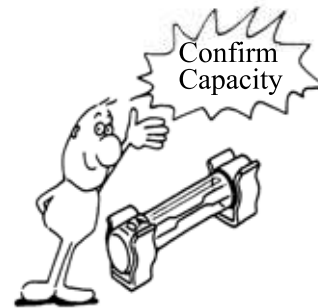

- After operation, terminal caps shall be installed securely.



- When taking out the connector, the lock on the connector shall be released before operation.

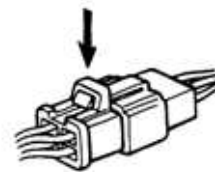

- Hold the connector body when connecting or disconnecting it.
- Do not pull the connector wire.



- Check if any connector terminal is bending, protruding or loose.

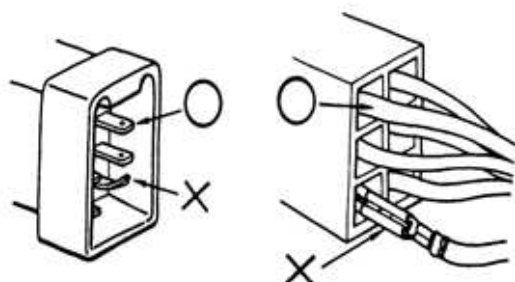

# 1. GENERAL INFORMATION

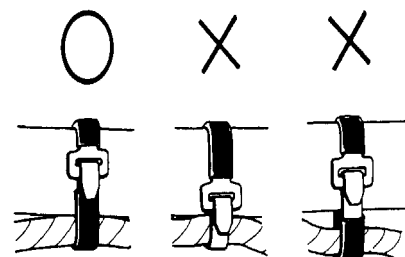
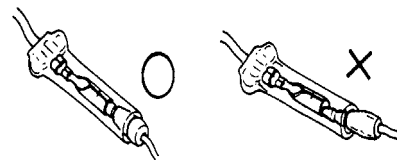
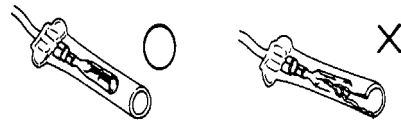
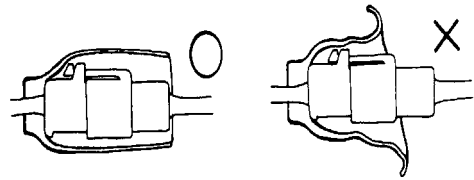
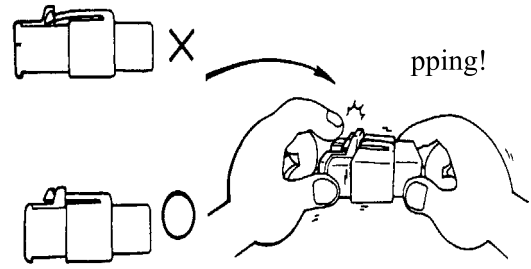

# 1. GENERAL INFORMATION

- After clamping, check each wire to make sure it is secure.

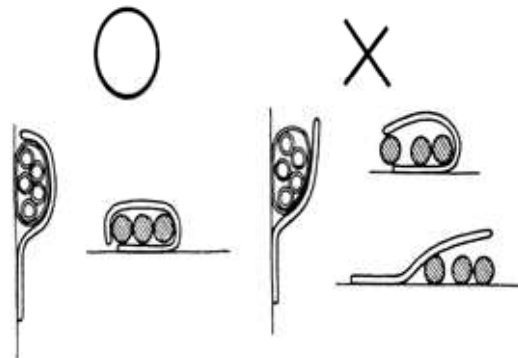

- Do not squeeze wires against the weld or its clamp.



- After clamping, check each harness to make sure that it is not interfering with any moving or sliding parts.

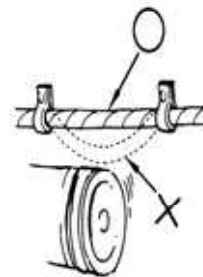

- When fixing the wire harnesses, do not make it contact the parts which will generate high heat.

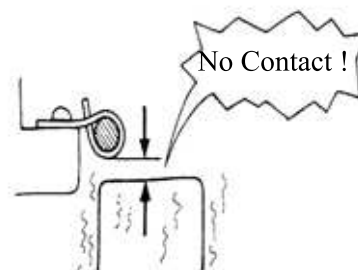

- Route wire harnesses to avoid sharp edges or corners. Avoid the projected ends of bolts and screws.
- Route wire harnesses passing through the side of bolts and screws. Avoid the projected ends of bolts and screws.

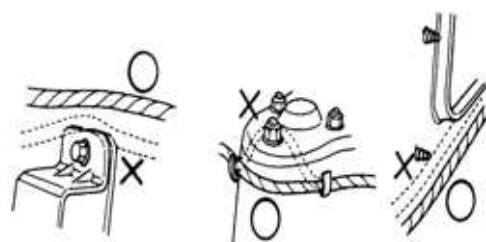

# 1. GENERAL INFORMATION

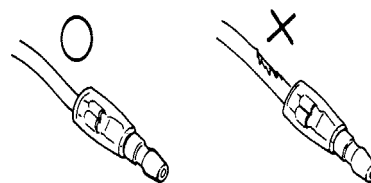
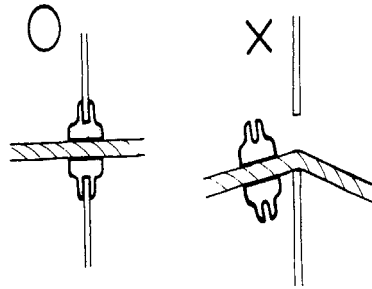
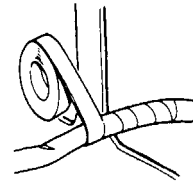
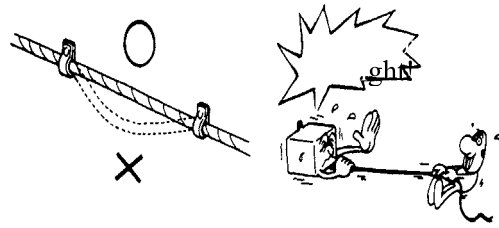

Do not press  
or squeeze  
the wire.

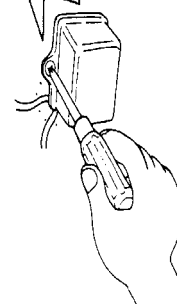

- After routing, check that the wire harnesses are not twisted or kinked.

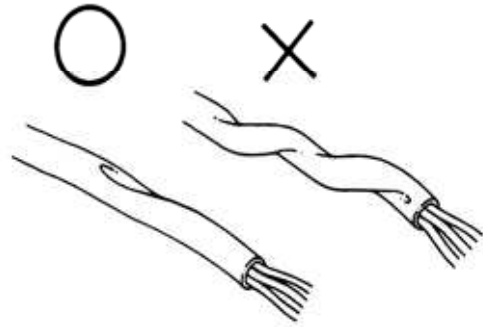

- Wire harnesses routed along with handlebar should not be pulled tight, have excessive slack or interfere with adjacent or surrounding parts in all steering positions.

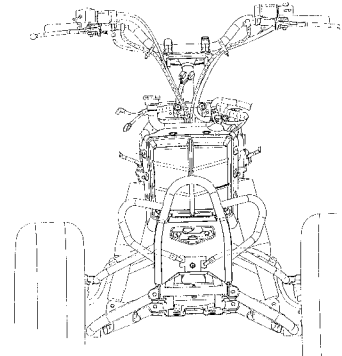

- When a testing device is used, make sure to understand the operating methods thoroughly and operate according to the operating instructions.

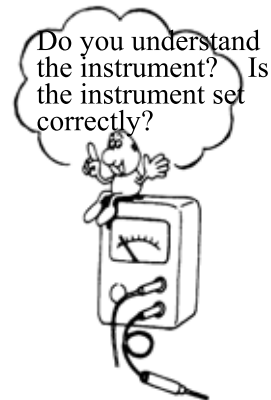

- Be careful not to drop any parts.



- When rust is found on a terminal, remove the rust with sand paper or equivalent before connecting.



# 1. GENERAL INFORMATION

---

## ■ Symbols:

The following symbols represent the servicing methods and cautions included in this service manual.



: Apply engine oil to the specified points. (Use designated engine oil for lubrication.)



: Apply grease for lubrication.



: Transmission Gear Oil (90#)



: Use special tool.



: Caution



: Warning

# 1. GENERAL INFORMATION



## TORQUE VALUES

### STANDARD TORQUE VALUES

Item	Torque (kgf-m)	Item	Torque (kgf-m)
5mm bolt and nut	0.45~0.6	4mm screw	0.2~0.4
6mm bolt and nut	0.8~1.2	5mm screw	0.35~0.5
8mm bolt and nut	1.8~2.5	6mm screw, SH bolt	0.7~1.1
10mm bolt and nut	3.0~4.0	6mm flange bolt and nut	1.0~1.4
12mm bolt and nut	5.0~6.0	8mm flange bolt and nut	2.4~3.0
14mm bolt and nut	6.0~8.0	10mm flange bolt and nut	3.5~4.5

Torque specifications listed below are for important fasteners.

### ENGINE (Mongoose/KXR 90)

Item	Q'ty	Thread dia.(mm)	Torque (kgf-m)	Remarks
Stud bolt	4	8	0.7~1.1	
Oil filter screen cap	1	30	1.0~2.0	
L cover	8	6	1.0~1.4	
Cam shaft holder	4	8	1.8~2.2	Apply oil 
Tappet ADJ nut	2	5	0.7~1.1	Apply oil 
Pivot tensioner bolt	1	6	0.8~1.2	
Lifter tensioner bolt	2	6	1.0~1.4	
Lifter tensioner cap	1	6	0.35~0.5	
Mission case bolt	7	8	2.4~3.0	
Mission fill bolt	1	8	1.0~2.0	
Driver face nut	1	12	5.5~6.5	Apply oil 
Clutch outer nut	1	10	3.5~4.5	
Drive plate nut	1	28	5.0~6.0	
Oneway clutch bolt	3	6	1.0~1.4	Apply thread lock
Oneway clutch nut	1	24	5.0~6.0	
ACG flywheel nut	1	10	3.5~4.5	
Spark plug	1	10	1.0~1.4	
Drain plug	1	10	2.0~3.0	
Oil pump screw	1	3	0.1~0.3	
Head CYL stud bolt (IN pipe)	2	6	0.7~1.1	
Head CYL stud bolt (EX pipe)	2	8	0.7~1.1	
A.C.G Startor	3	5	0.8~1.0	
Fan	4	6	0.6~1.0	

# 1. GENERAL INFORMATION

## ENGINE (Mongoose/KXR 50)

Item	Q'ty	Thread dia.(mm)	Torque (kgf-m)	Remarks
Cylinder head bolt	4	6	0.8~1.2	
Clutch drive plate nut	1	28	5.0~6.0	
Drive face nut	1	10	3.5~4.5	
Clutch outer nut	1	10	3.5~4.5	
ACG flywheel nut	1	10	3.5~4.5	
Mission fill bolt	1	8	1.0~2.0	
Drive plate nut	1	28	5.0~6.0	
Spark plug	1	14	1.1~1.7	

## FRAME

Item	Q'ty	Thread dia.(mm)	Torque (kgf-m)	Remarks
Steering stem nut	1	14	6.0~8.0	
Front Swing arm nut	4	10	4.0~5.0	
Front wheel nut	8	10	4.0~5.0	
Rear wheel nut	8	10	4.0~5.0	
Front wheel hub nut	2	12	5.5~6.5	
Rear wheel hub nut	2	14	6.0~8.0	
Front shock absorber upper mount bolt	2	10	3.5~4.5	
Front shock absorber lower mount bolt	2	10	3.5~4.5	
Rear shock absorber upper mount bolt	1	10	3.5~4.5	
Rear shock absorber lower mount bolt	1	10	3.5~4.5	
Rear swing arm axle hub bolt	1	14	6.0~8.0	
Rear axle hub nut	4	12	6.0~8.0	
Front engine bracket bolt	2	10	4.0~5.0	
Rear engine bracket bolt	2	8	2.0~2.4	
Rear caliper bolt	2	8	2.9~3.5	
Brake oil bolt	2	10	3.0~4.0	
M/C holder	2	6	1.0~1.4	
Exhaust muffler lock bolt (frame)	2	8	3.2~3.8	
Exhaust muffler lock nut (engine)	2	8	1.8~2.2	
Rod-end nut	4	8	2.5~3.5	



# 1. GENERAL INFORMATION

## SPECIAL TOOLS (Mongoose/KXR 90)

Tool Name	Tool No.	Remarks Ref. Page
Clutch spring compressor	E034	
Bearing puller	E037	
Valve spring compressor	E040	
Oil seal & bearing installer	E014	
Tappet adjuster	E036	
Long socket wrench	E015	
Start clutch puller	E006	
Flywheel puller	E001	
Universal holder	E017	
Float level gauge		

## SPECIAL TOOLS (Mongoose/KXR 50)

Tool Name	Tool No.	Remarks Ref. Page
Flywheel puller	E001	
Oil seal and bearing install	E014	
Universal holder	E017	
Clutch spring compressor	E034	
Bearing puller	E037	
Crankshaft install	E016	
Crankshaft & crankcase install	E024	
Crankcase puller	E026	
Crankshaft Bearing puller	E030	
Float level gauge		

## LUBRICATION POINTS

### ENGINE

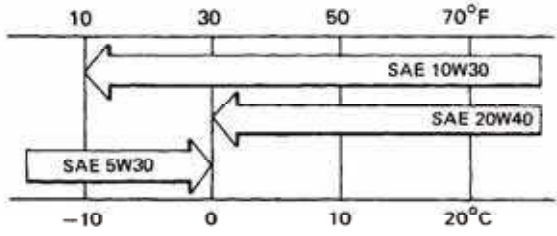
Lubrication Points	Lubricant
Valve guide/valve stem movable part Cam lobes Valve rocker arm friction surface Cam chain Cylinder lock bolt and nut Piston surroundings and piston ring grooves Piston pin surroundings Cylinder inside wall Connecting rod/piston pin hole Connecting rod big end Crankshaft right side oil seal Crankshaft one-way clutch movable part Oil pump drive chain Balance gear A.C. generator Starter one-way clutch Bearing movable part O-ring face Oil seal lip	<ul style="list-style-type: none"> <li>•Genuine KYMCO Engine Oil (SAE15W-40)</li> <li>•API SG Engine Oil</li> </ul> 
Transmission gear and movable parts	Gear oil: SAE90#

# 1. GENERAL INFORMATION

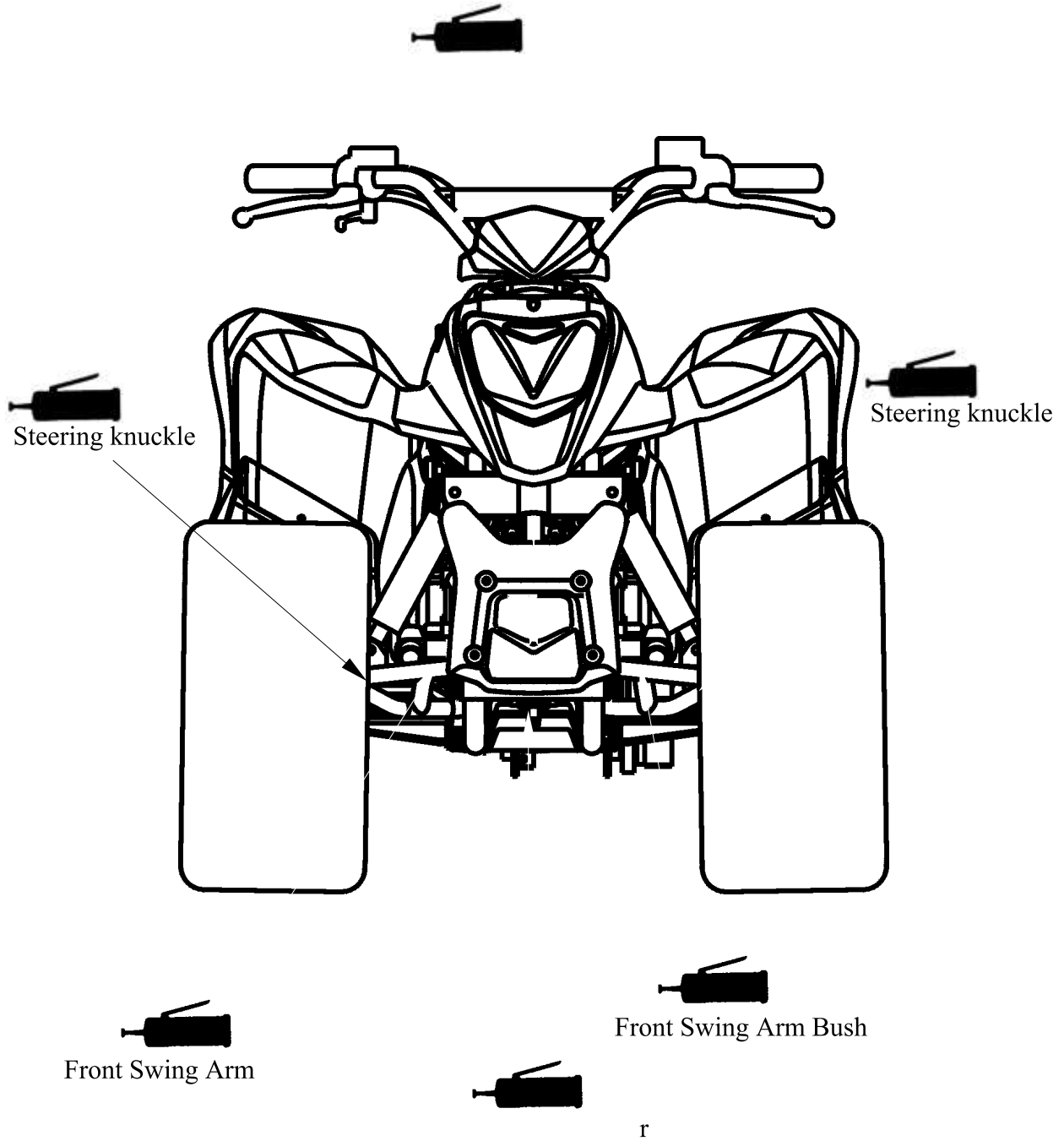

# 1. GENERAL INFORMATION

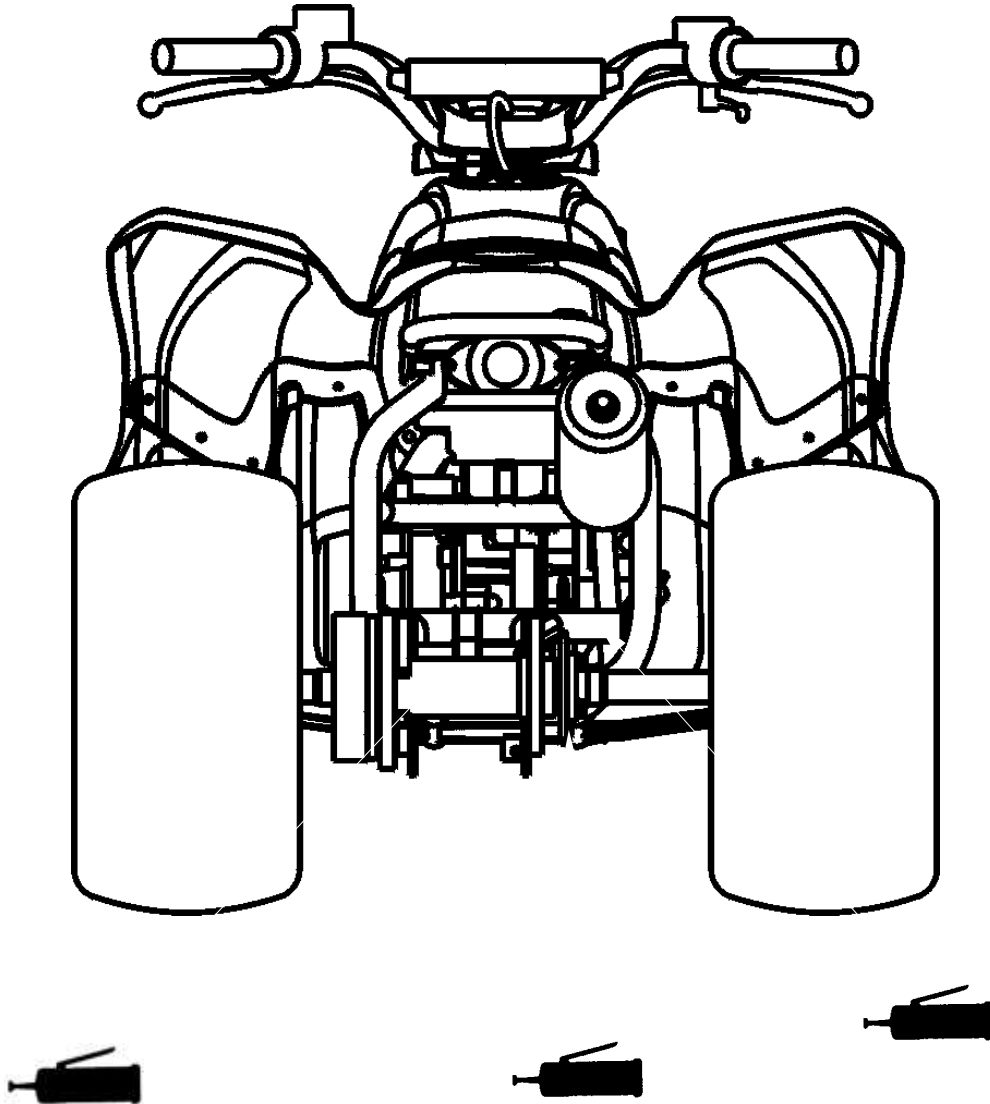

# 1. GENERAL INFORMATION

## CABLE & HARNESS ROUTING

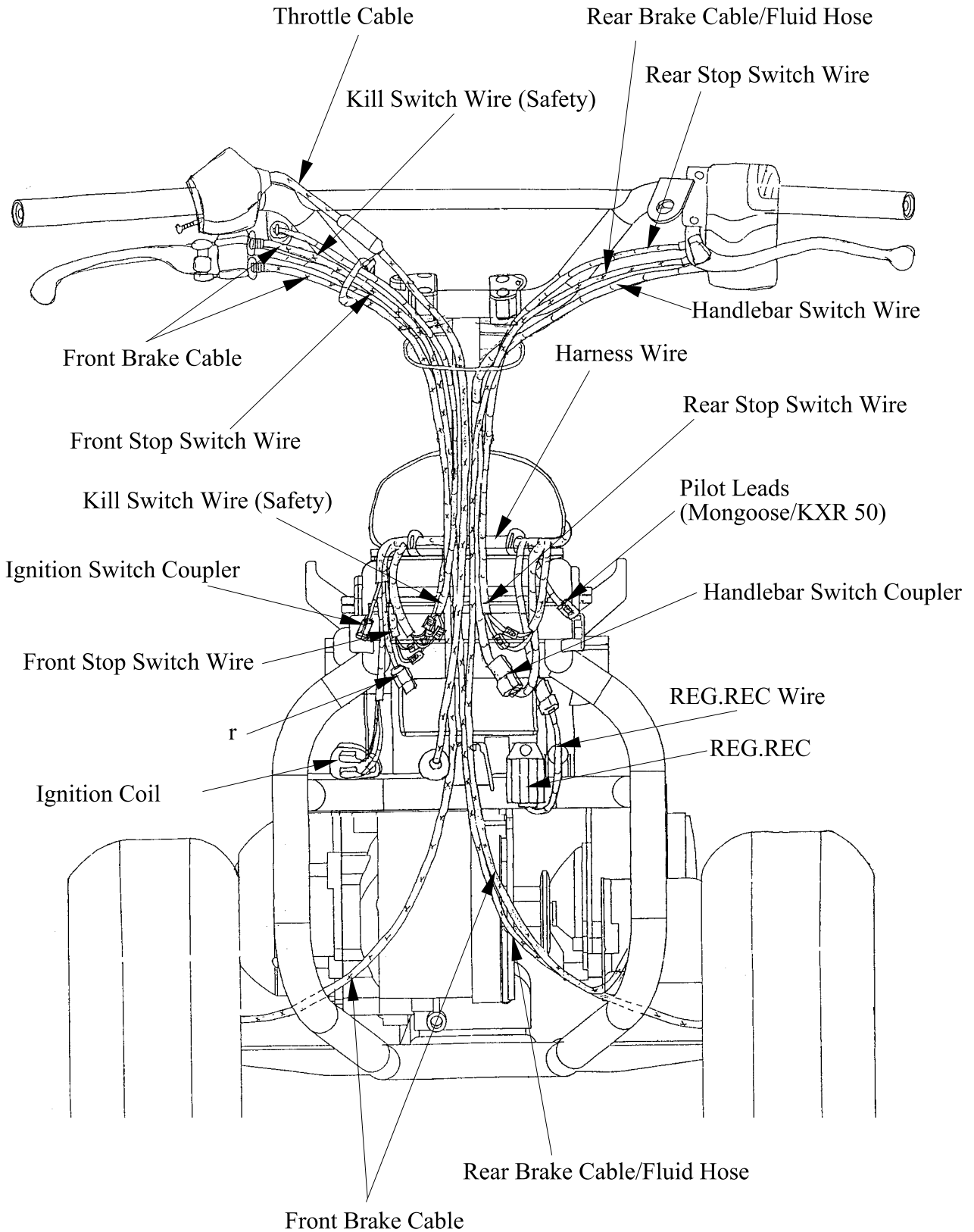

# 1. GENERAL INFORMATION

---

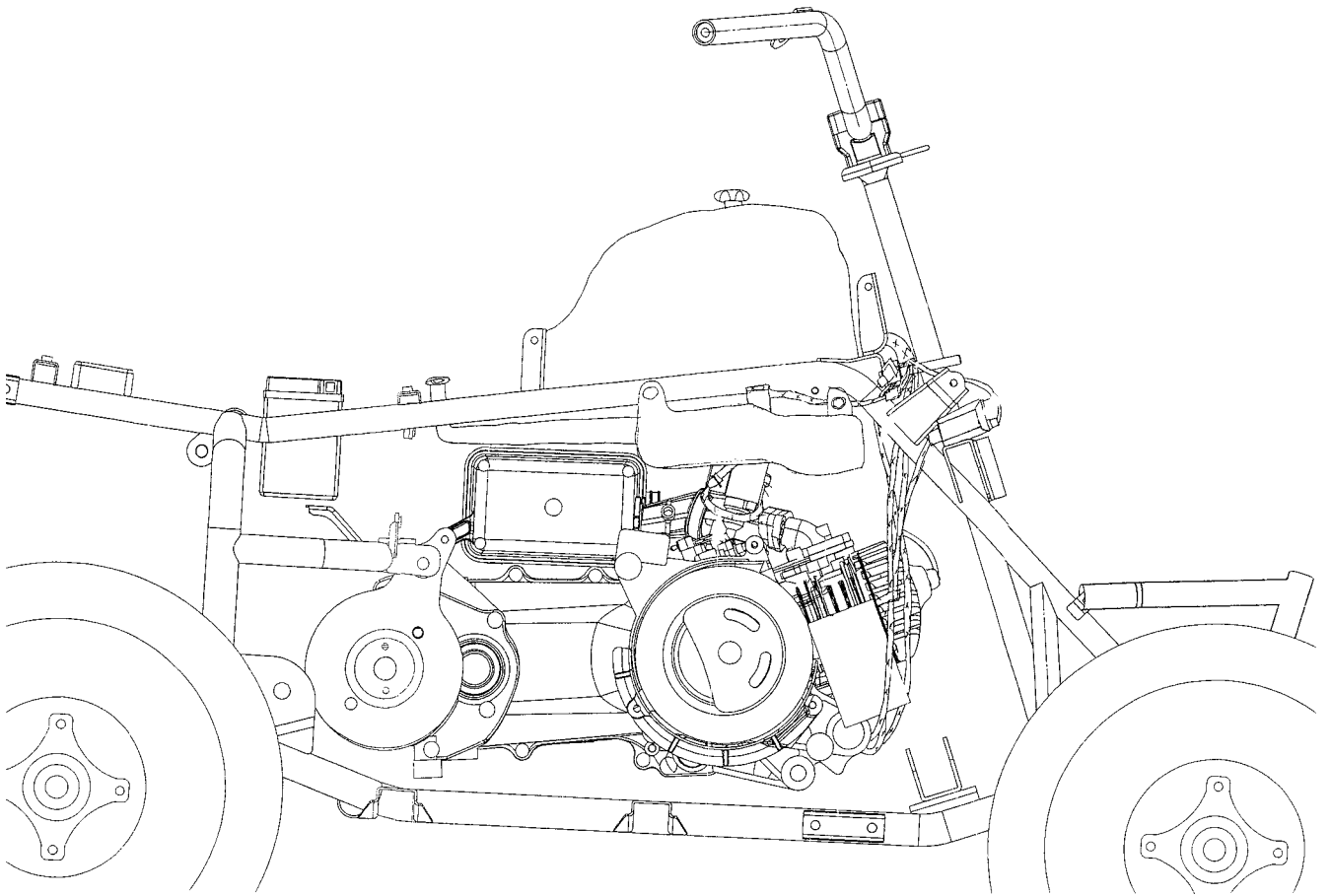

# 1. GENERAL INFORMATION

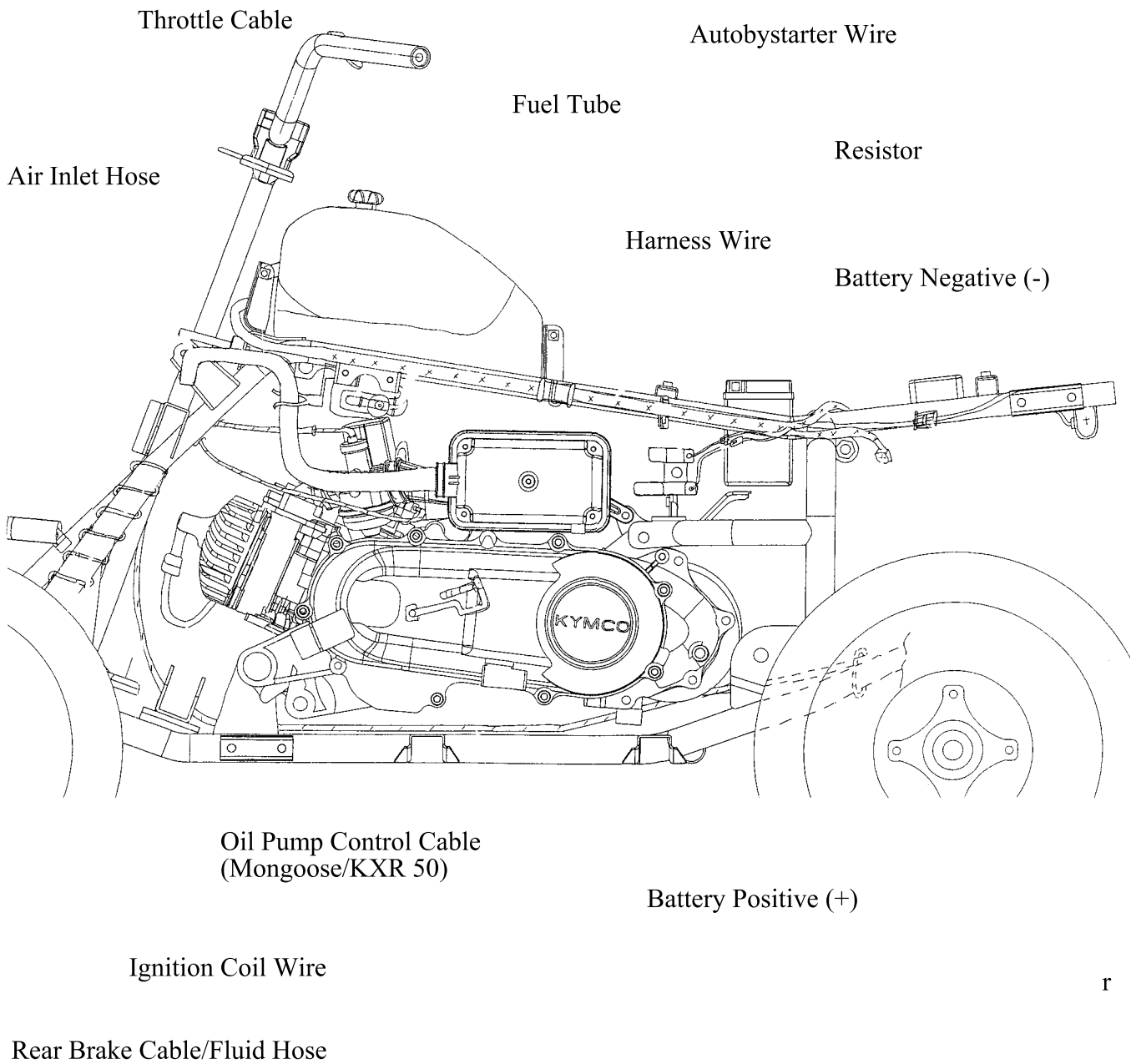

r

# 1. GENERAL INFORMATION

## WIRING DIAGRAM (Mongoose/KXR 90 OFF ROAD)

COLOR COMB GROUND/MARKINGS

B	BLACK	BR	BROWN
Y	YELLOW	O	ORANGE
L	BLUE	SB	SKY BLUE
G	GREEN	LG	LIGHT GREEN
R	RED	P	PINK
W	WHITE	GR	GRAY

DIMMER SW

HL	LO	HI	RE
<input type="radio"/>	<input type="radio"/>	<input type="radio"/>	<input type="radio"/>
HL	LO	HI	RE
<input type="radio"/>	<input type="radio"/>	<input type="radio"/>	<input type="radio"/>
HL	LO	HI	RE
<input type="radio"/>	<input type="radio"/>	<input type="radio"/>	<input type="radio"/>

START SW

ST	E
<input type="radio"/>	<input type="radio"/>
ST	E
<input type="radio"/>	<input type="radio"/>
ST	E
<input type="radio"/>	<input type="radio"/>

COMB SW

LOCK	IG	E	Part 2
<input type="radio"/>	<input type="radio"/>	<input type="radio"/>	<input type="radio"/>
LOCK	IG	E	Part 2
<input type="radio"/>	<input type="radio"/>	<input type="radio"/>	<input type="radio"/>
LOCK	IG	E	Part 2
<input type="radio"/>	<input type="radio"/>	<input type="radio"/>	<input type="radio"/>

SW UNIT KILL (SAFETY)

E	IG
<input type="radio"/>	<input type="radio"/>
E	IG
<input type="radio"/>	<input type="radio"/>
E	IG
<input type="radio"/>	<input type="radio"/>

KILL SW

E	IG
<input type="radio"/>	<input type="radio"/>
E	IG
<input type="radio"/>	<input type="radio"/>
E	IG
<input type="radio"/>	<input type="radio"/>

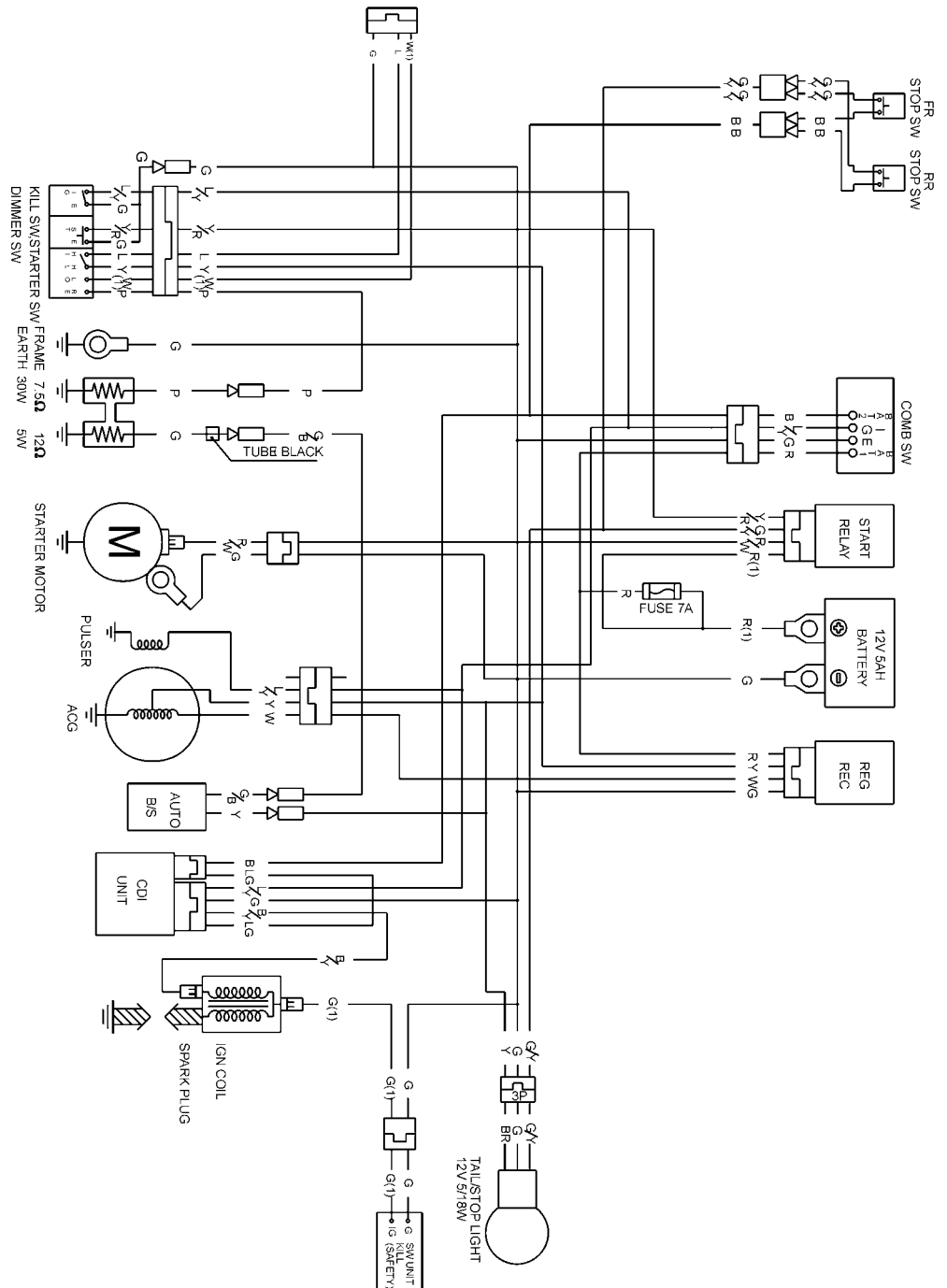



# 1. GENERAL INFORMATION

## WIRING DIAGRAM (KXR 90 ON ROAD)

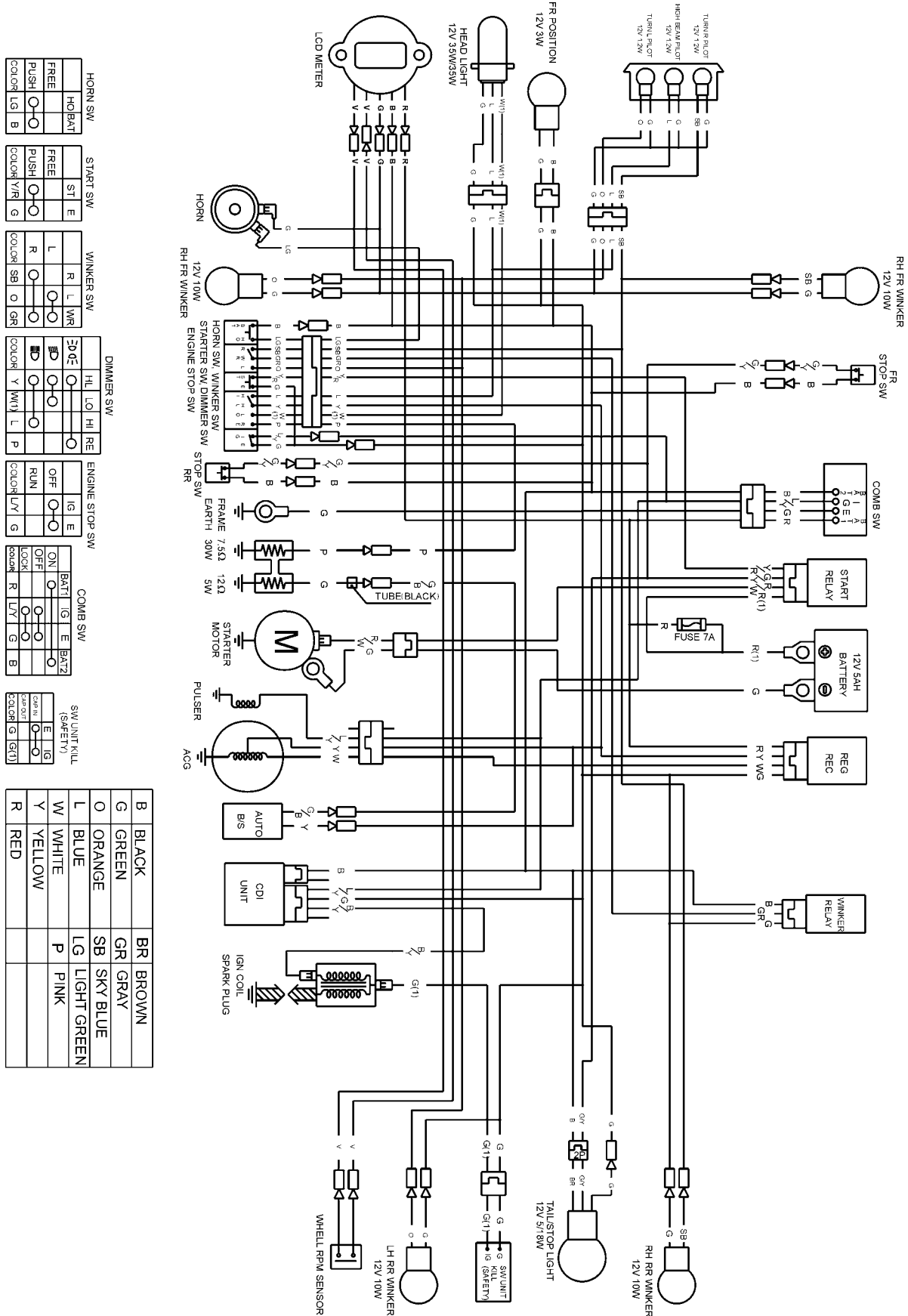

HORN SW	HO/BAT	START SW	ST	E	WINKER SW	R	L	WR	DIMMER SW	HL	LO	HI	RE	ENGINE STOP SW	IG	E	COMB SW	BAT	G	E	BATZ	SW UNIT KILL (SAFETY)	CH	IG	CH	OUT	CH	OUT		
COLOR LG	B	COLOR Y/R	G	COLOR SB	O	GR	COLOR Y	W(1)	L	P	COLOR L/V	G	COLOR Y	W(1)	L	P	COLOR L/V	G	COLOR R	L	V	G	B	COLOR G	IG(1)	COLOR R	L	V	G	B

B	BLACK	BR	BROWN
G	GREEN	GR	GRAY
O	ORANGE	SB	SKY BLUE
L	BLUE	LG	LIGHT GREEN
W	WHITE	P	PINK
Y	YELLOW		
R	RED		

# 1. GENERAL INFORMATION

## WIRING DIAGRAM (Mongoose/KXR 50 OFF ROAD)

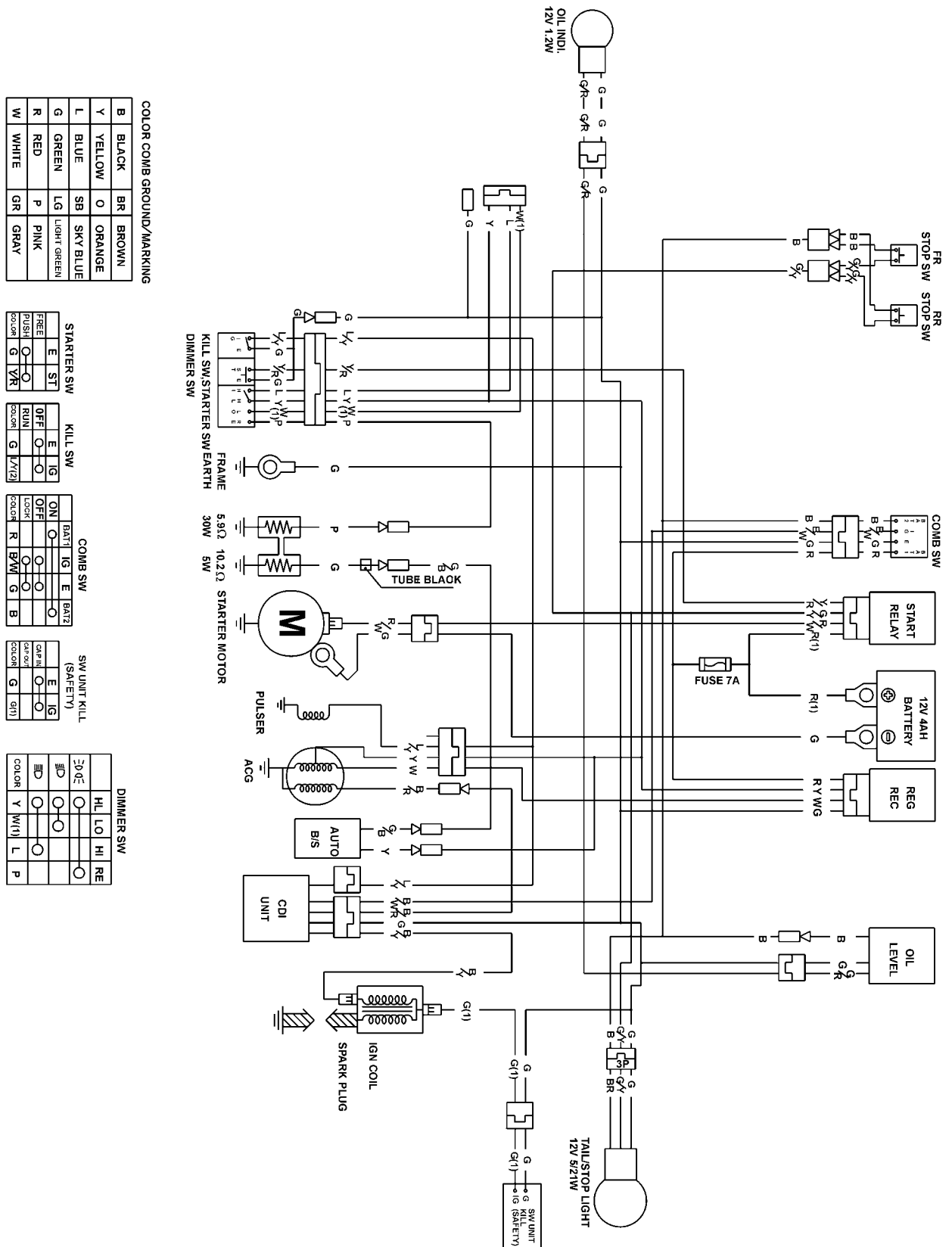

COLOR COMB GROUND/MARKING

B	BLACK	BR	BROWN
Y	YELLOW	O	ORANGE
L	BLUE	SB	SKY BLUE
G	GREEN	LG	LIGHT GREEN
R	RED	P	PINK
W	WHITE	GR	GRAY

FREE	E	ST
PUSH	O	O
COLOR	G	Y/R

STARTER SW

OFF	E	IG
RUN	O	O
COLOR	G	L/Y/Z

KILL SW

ON	IG	E	BATZ
OFF	O	O	O
LOCK	R	B/W	G
COLOR			B

COMB SW

ON	E	IG
OFF	O	O
COLOR	G	Y/R

SW UNIT KILL (SAFETY)

30GE	HL	LO	HI	RE
ED	O	O	O	O
ED	O	O	O	O
COLOR	Y	W(1)	L	P

DIMMER SW

# 1. GENERAL INFORMATION

## WIRING DIAGRAM (KXR 50 ON ROAD)

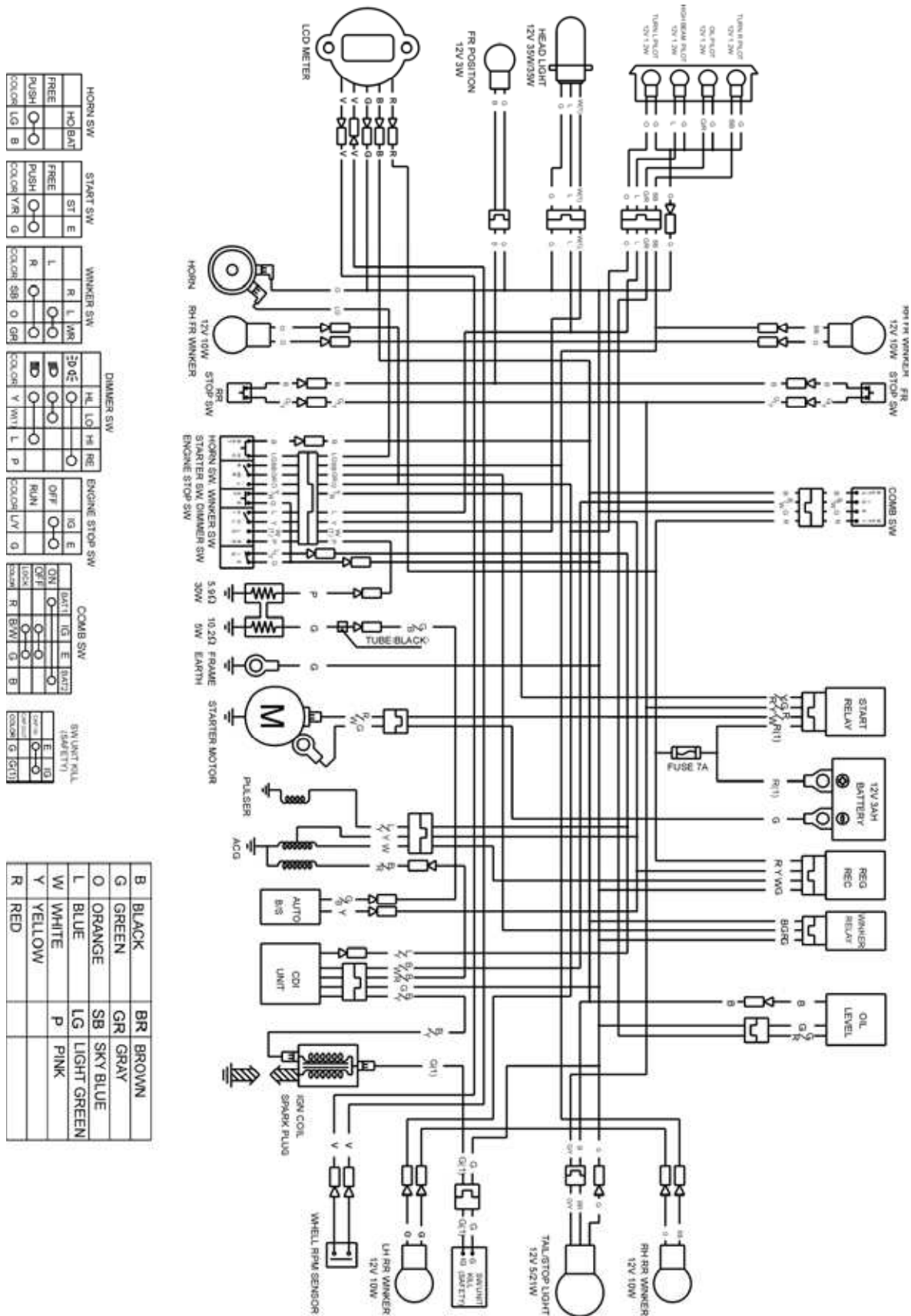

# 1. GENERAL INFORMATION

## TROUBLESHOOTING

### ENGINE WILL NOT START OR IS HARD TO START

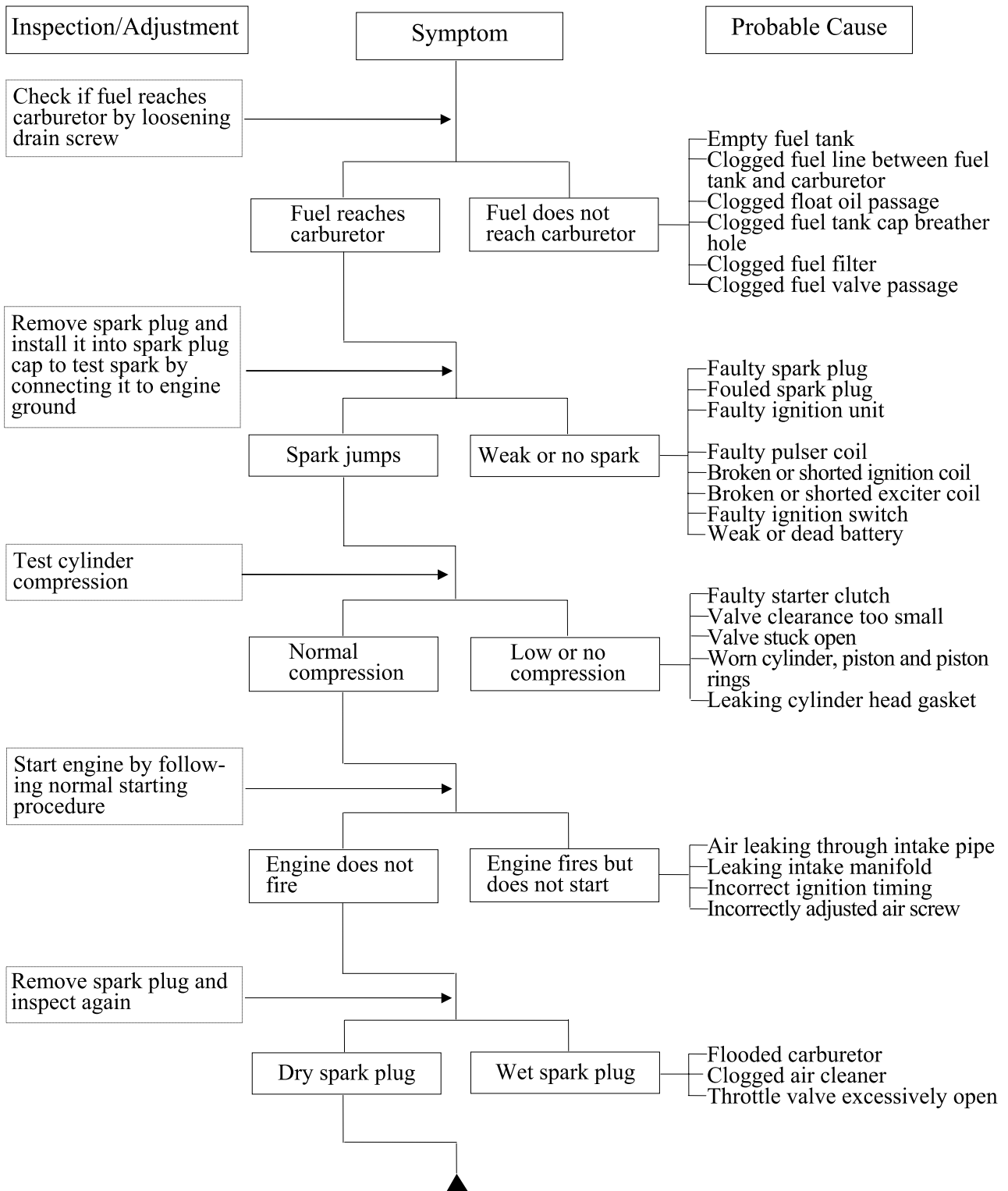

# 1. GENERAL INFORMATION

## ENGINE LACKS POWER

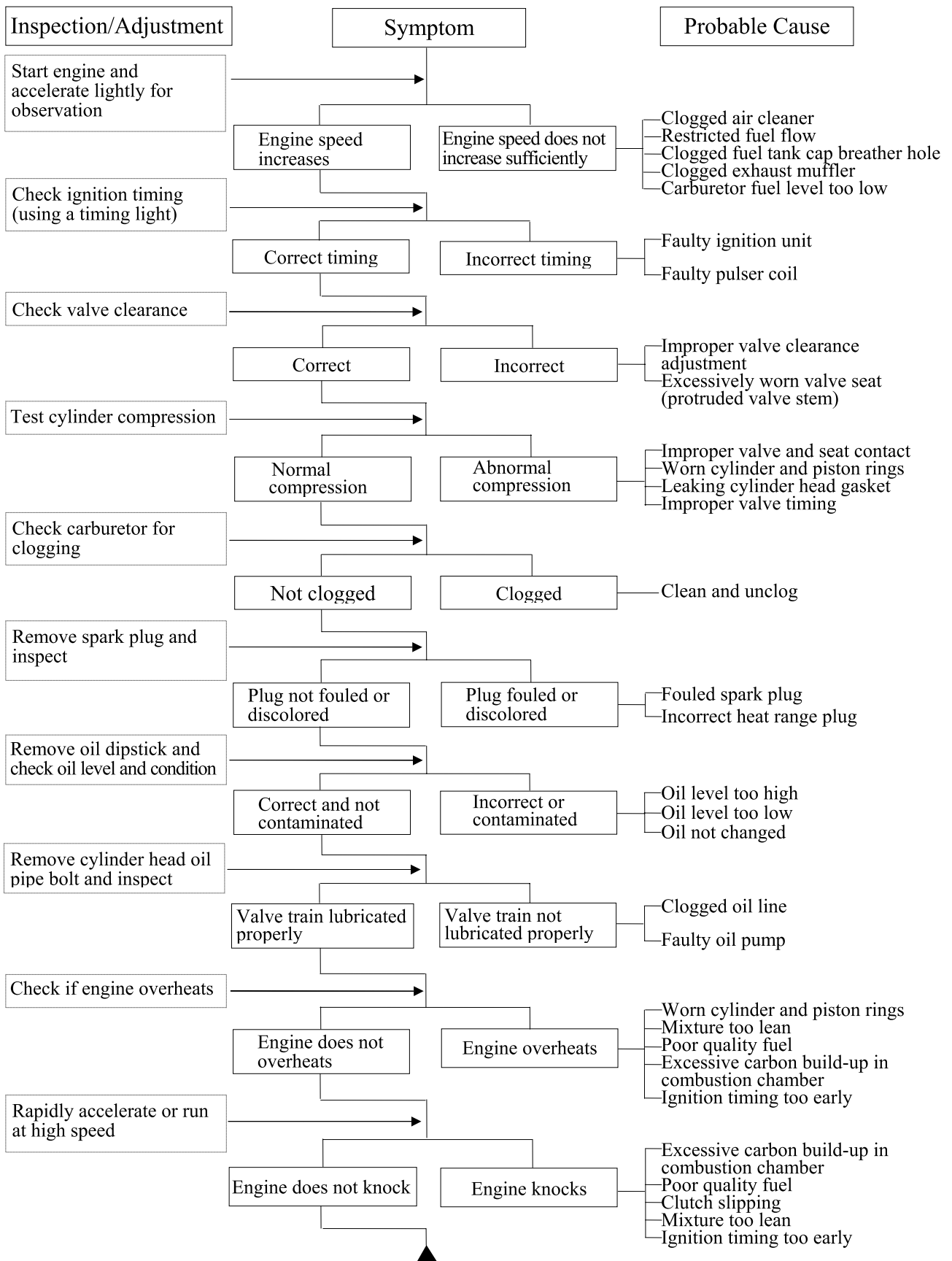

# 1. GENERAL INFORMATION

## POOR PERFORMANCE (ESPECIALLY AT IDLE AND LOW SPEEDS)

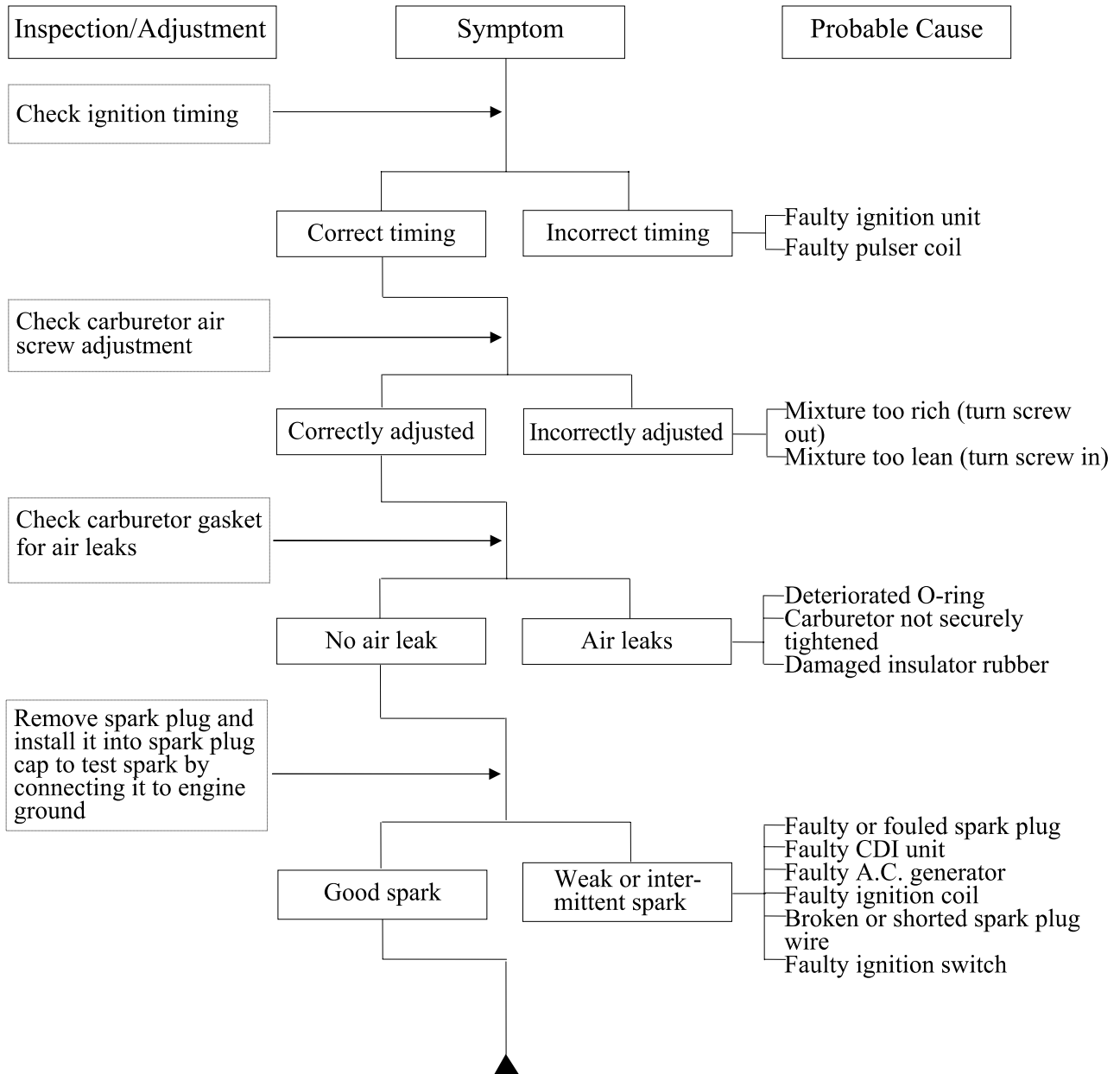

# 1. GENERAL INFORMATION

## POOR PERFORMANCE (AT HIGH SPEED)

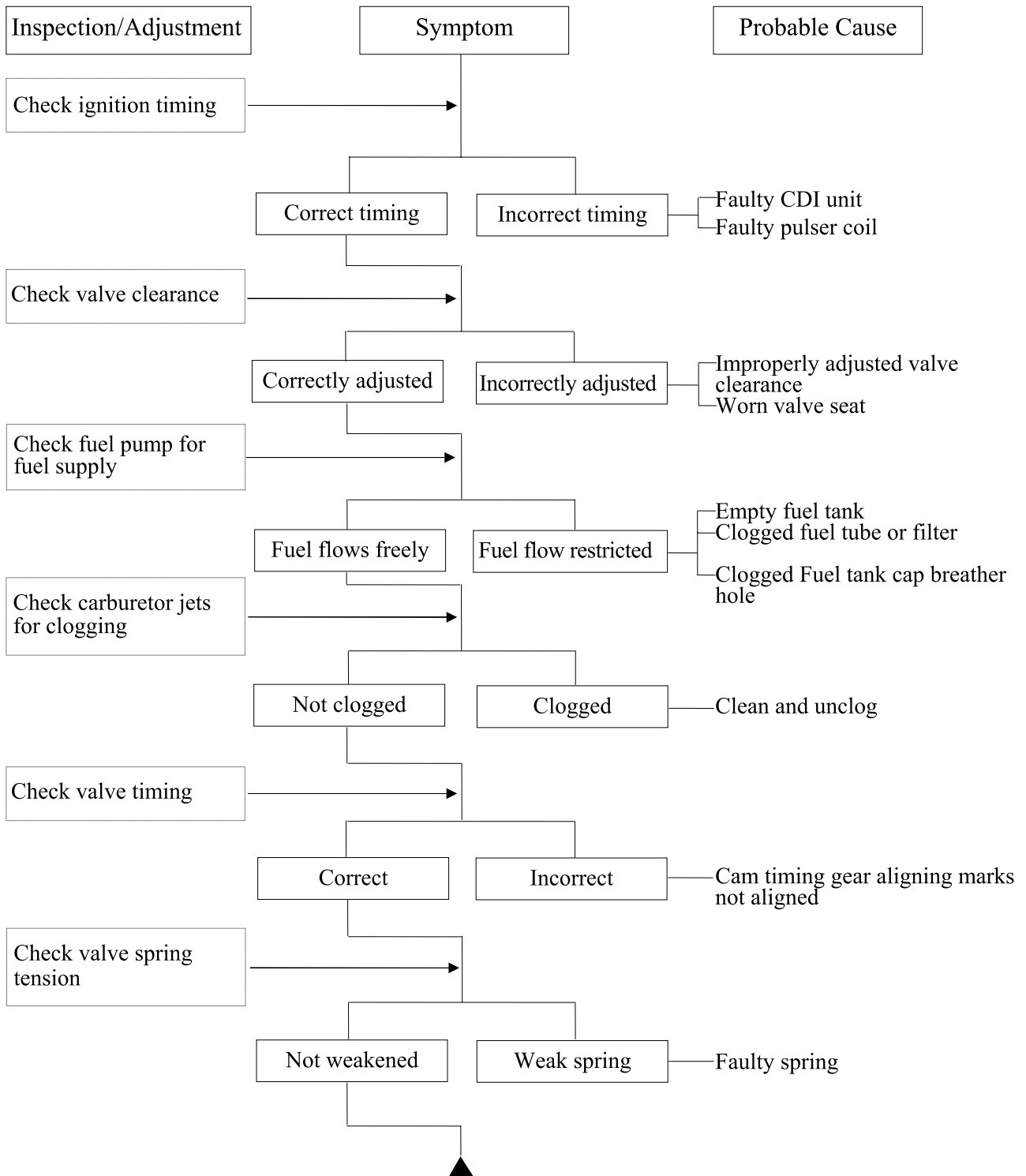

# 1. GENERAL INFORMATION

## POOR CHARGING (BATTERY OVER DISCHARGING OR OVERCHARGING)

### Undercharging

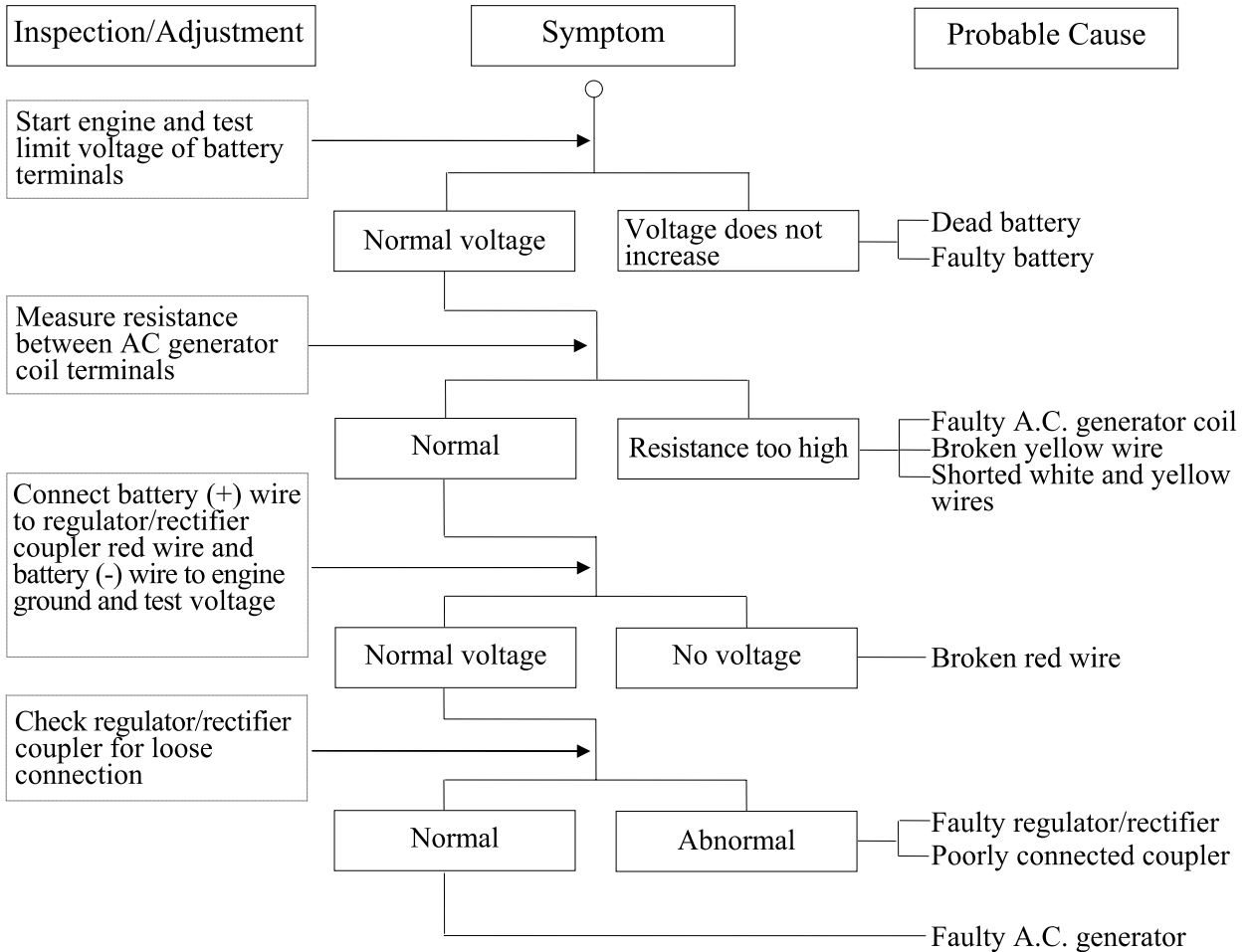

### Overcharging

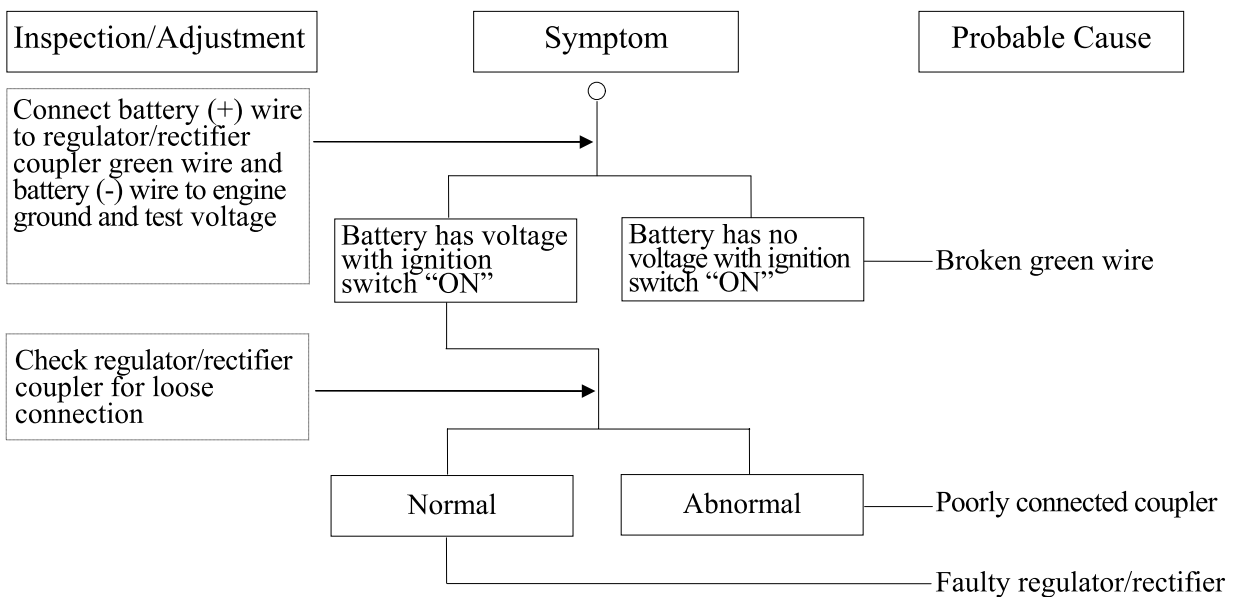



# 1. GENERAL INFORMATION

## NO SPARK AT SPARK PLUG

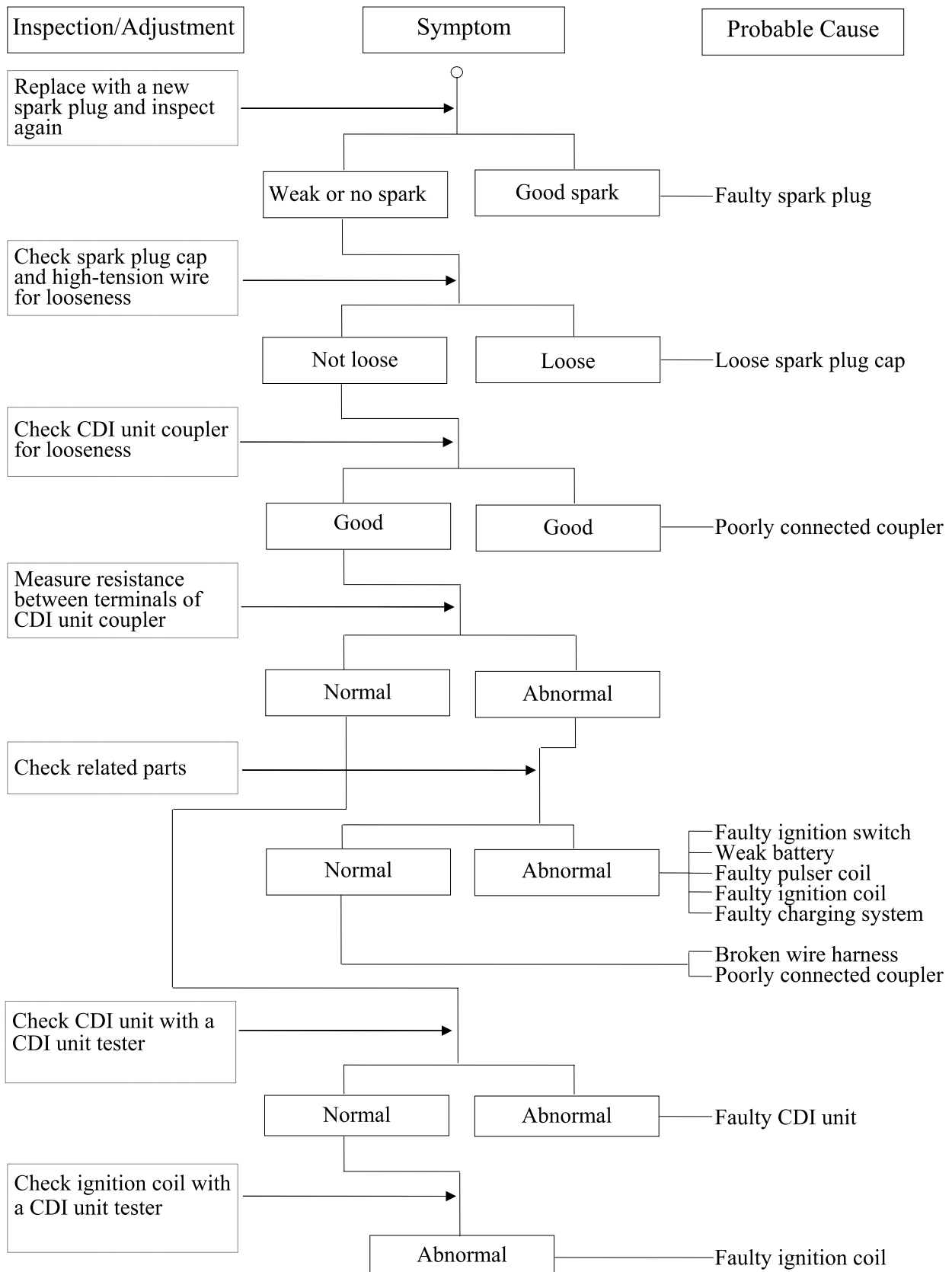

## **2. FRAME COVERS/EXHAUST MUFFLER**

---

## 2. FRAME COVERS/EXHAUST MUFFLER

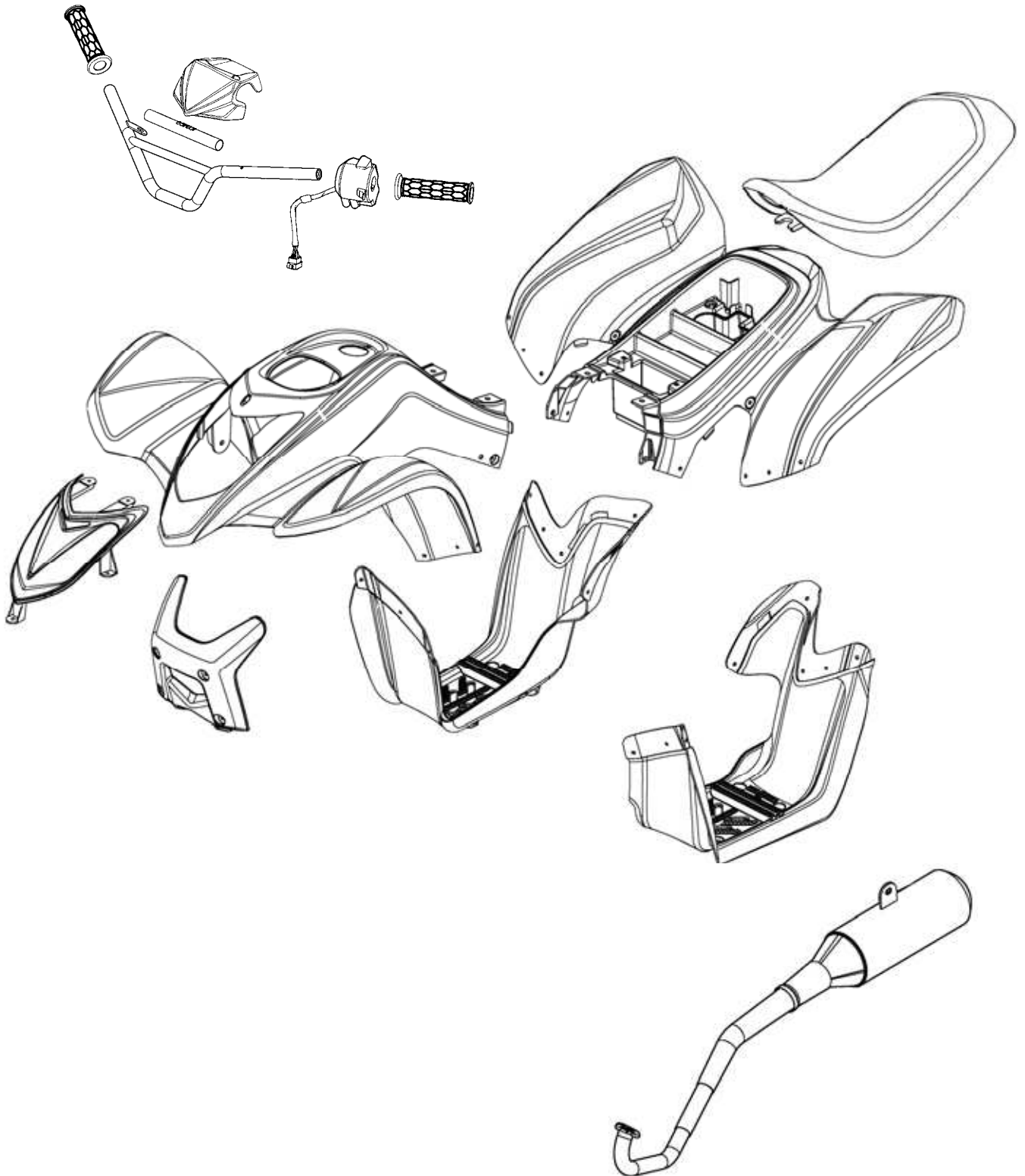

## **2. FRAME COVERS/EXHAUST MUFFLER**

---

## 2. FRAME COVERS/EXHAUST MUFFLER

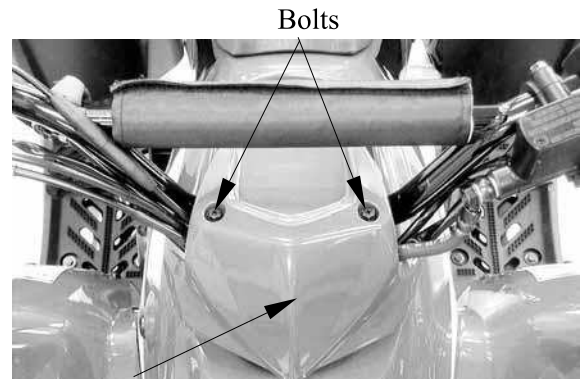

Handlebar Cover

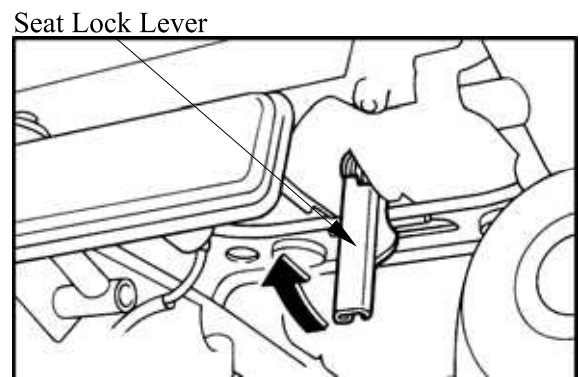

Seat

\* Make sure that the seat is securely fitted.

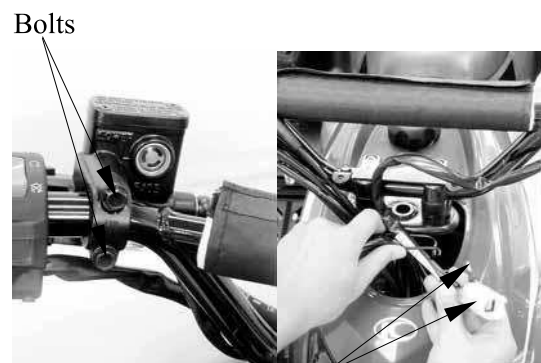

Handlebar Switch Coupler and Lead

## 2. FRAME COVERS/EXHAUST MUFFLER

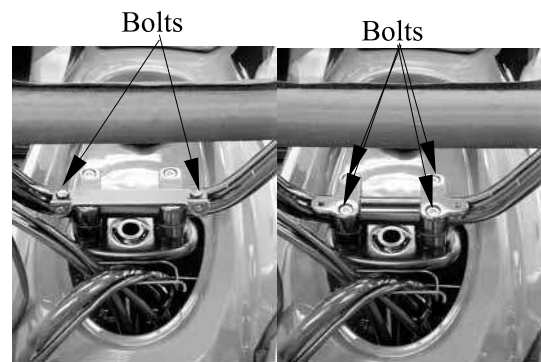
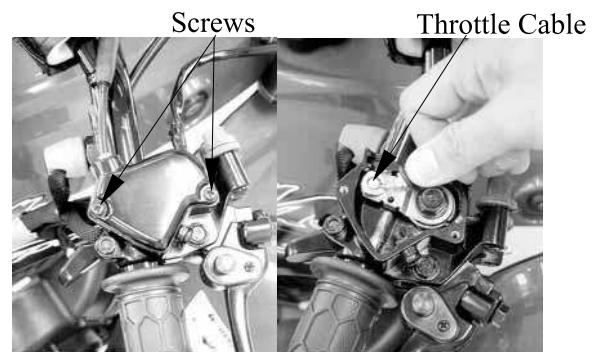
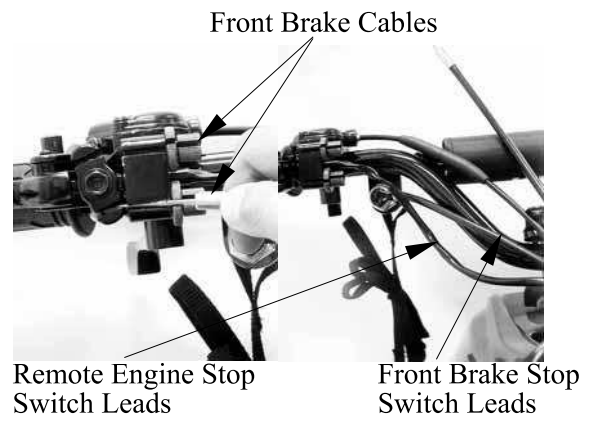

\*

## 2. FRAME COVERS/EXHAUST MUFFLER

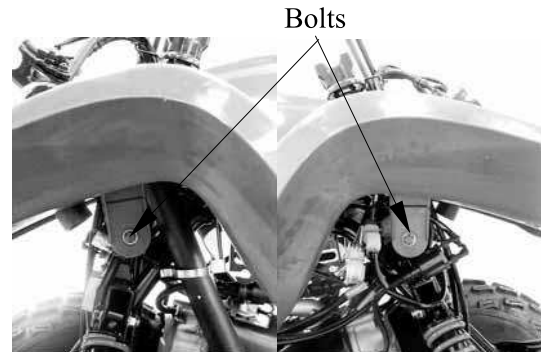
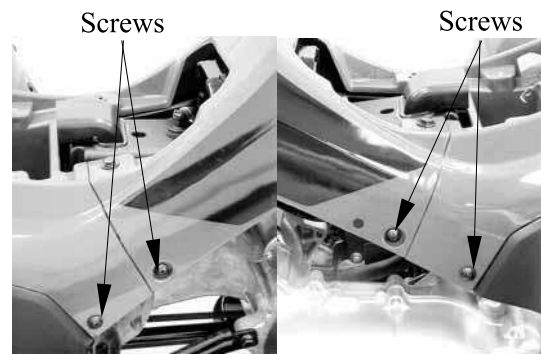
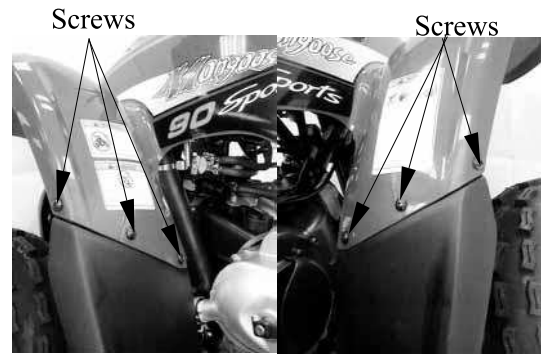

\* After remove, be sure to tighten the fuel filler cap.

\*

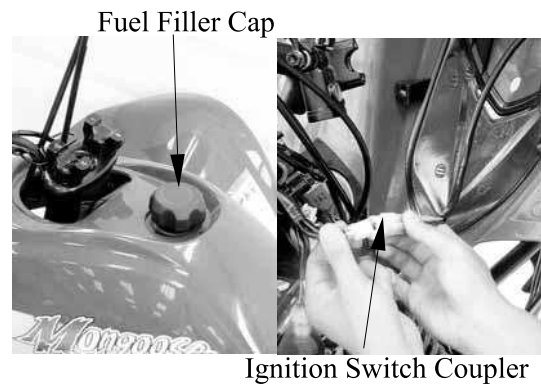

## 2. FRAME COVERS/EXHAUST MUFFLER

\*

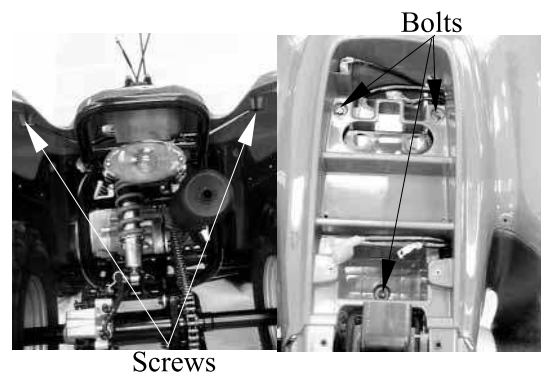
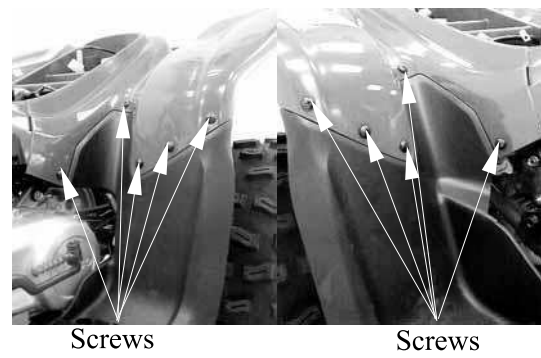
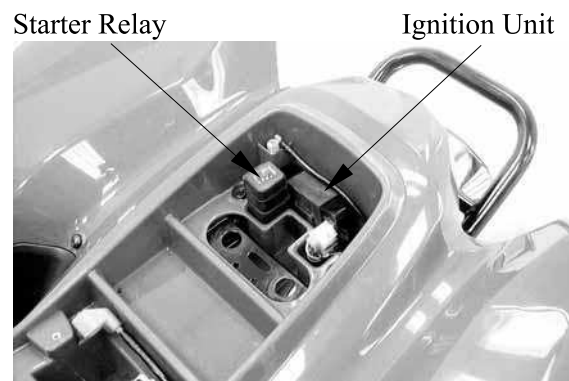



## 2. FRAME COVERS/EXHAUST MUFFLER

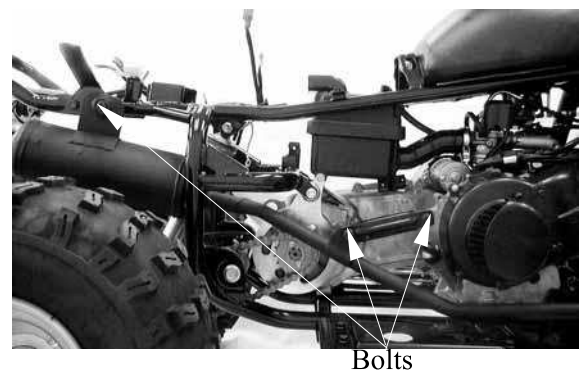
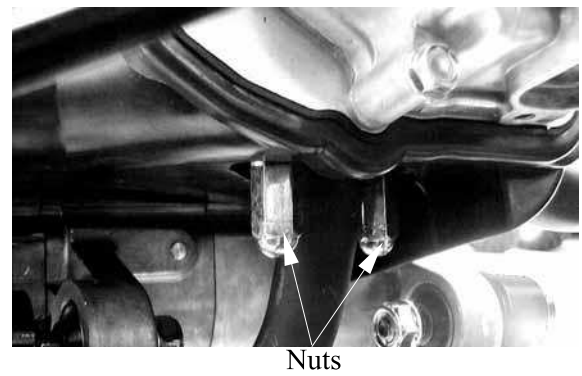
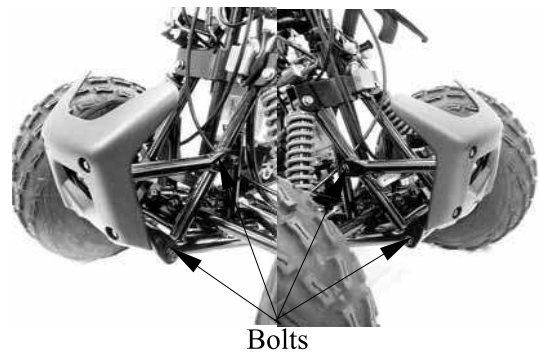
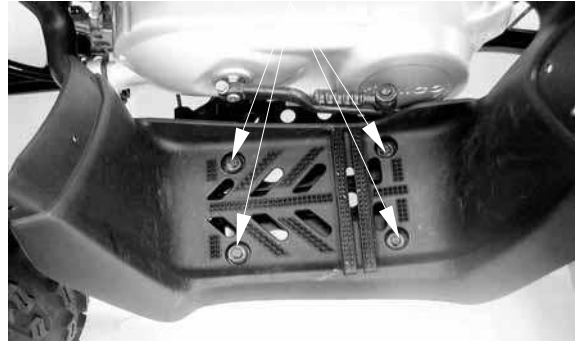

## 2. FRAME COVERS/EXHAUST MUFFLER

---

\*

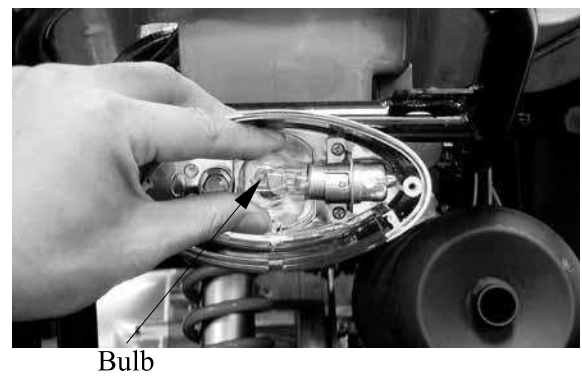
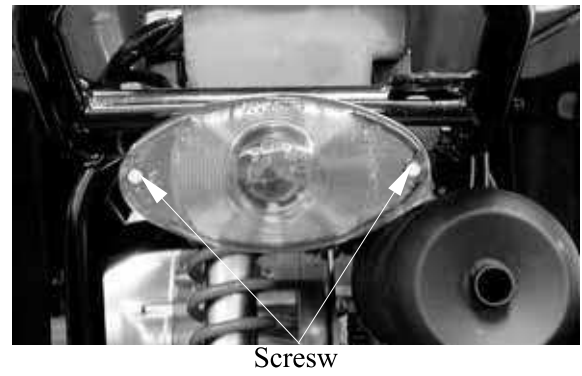
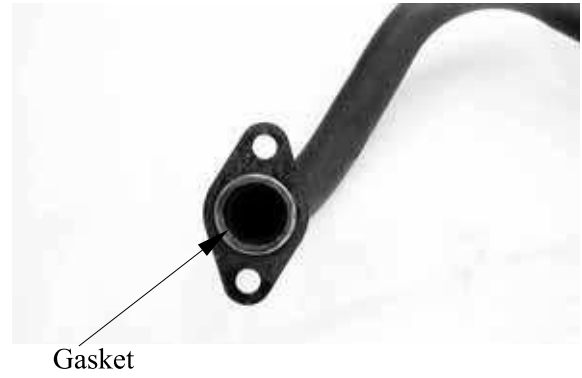

### **3. INSPECTION/ADJUSTMENT**

---

### **3. INSPECTION/ADJUSTMENT**

---

### **3. INSPECTION/ADJUSTMENT**

---

### 3. INSPECTION/ADJUSTMENT

						year
<b>Valves (Mongoose/KXR 50)</b>	Check valve clearance. Adjust if necessary.	<input type="radio"/>		<input type="radio"/>	<input type="radio"/>	<input type="radio"/>
<b>Spark plug</b>	Check condition. Clean or replace if necessary.	<input type="radio"/>	<input type="radio"/>	<input type="radio"/>	<input type="radio"/>	<input type="radio"/>
<b>Air clearance</b>	Clean. Replace if necessary.		<input type="radio"/>	<input type="radio"/>	<input type="radio"/>	<input type="radio"/>
<b>Carburetor</b>	Check idle speed/starter operation. Adjust if necessary.		<input type="radio"/>	<input type="radio"/>	<input type="radio"/>	<input type="radio"/>
<b>Fuel line</b>	Check fuel hose for cracks or damage. Replace if necessary.			<input type="radio"/>	<input type="radio"/>	<input type="radio"/>
<b>Engine oil (Mongoose/KXR 50)</b>	Replace (Warm engine before draining).	<input type="radio"/>		<input type="radio"/>	<input type="radio"/>	<input type="radio"/>
<b>Engine oil filter screen (Mongoose/KXR 50)</b>	Clean. Replace if necessary.	<input type="radio"/>				<input type="radio"/>
<b>Transmission oil</b>	Check oil leakage. Replace every 12 months.	<input type="radio"/>				<input type="radio"/>
<b>Brake system</b>	Check operation. Adjust if necessary.	<input type="radio"/>	<input type="radio"/>	<input type="radio"/>	<input type="radio"/>	<input type="radio"/>
<b>Drive belt</b>	Check operation/replace if damage or excessive wear.	<input type="radio"/>				<input type="radio"/>
<b>Wheels</b>	Check balance/damage/runout. Replace if necessary.	<input type="radio"/>		<input type="radio"/>	<input type="radio"/>	<input type="radio"/>
<b>Wheel bearings</b>	Check bearings assembly for looseness/damage. Replace if damaged.	<input type="radio"/>		<input type="radio"/>	<input type="radio"/>	<input type="radio"/>
<b>Steering system</b>	Check operation/replace if damage. Check toe-in/adjust if necessary.	<input type="radio"/>	<input type="radio"/>	<input type="radio"/>	<input type="radio"/>	<input type="radio"/>
<b>Knuckle shafts</b>	Lubricate every 6 months.			<input type="radio"/>	<input type="radio"/>	<input type="radio"/>
<b>Fitting/Fasteners</b>	Check all chassis fittings and fasteners. Correct if necessary.	<input type="radio"/>	<input type="radio"/>	<input type="radio"/>	<input type="radio"/>	<input type="radio"/>

- In the interest of safety, we recommend these items should be serviced only by an authorized KYMCO motorcycle dealer.

### 3. INSPECTION/ADJUSTMENT

\* Do not smoke or allow flames or sparks in your working area.

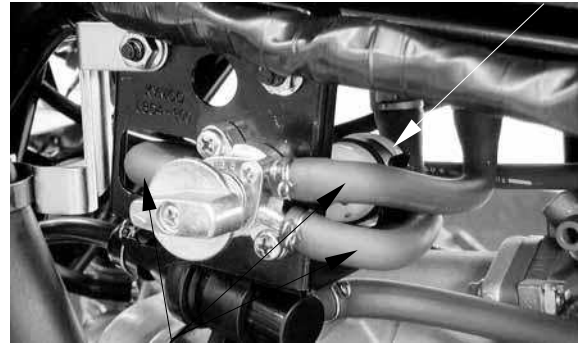

Fuel Tubes

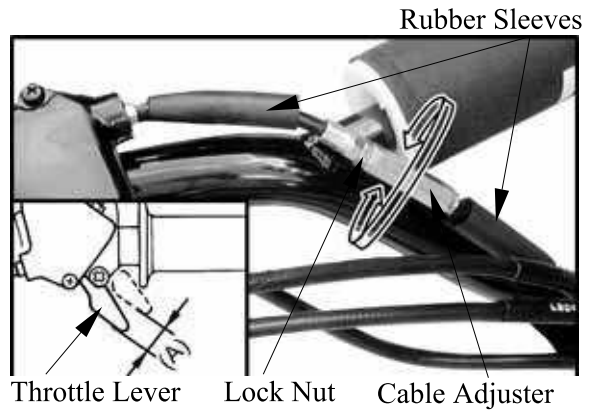

Throttle Lever Lock Nut Cable Adjuster

\* Adjust oil pump control cable after the throttle grip free play is adjusted.

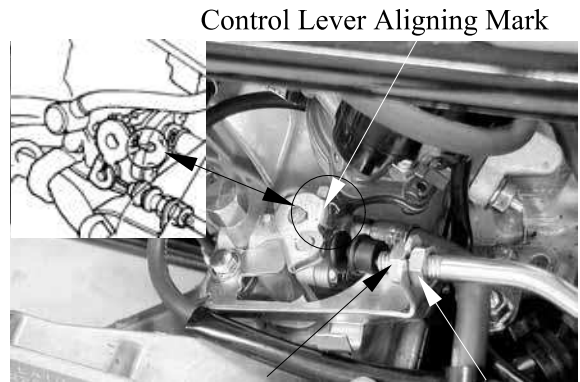

Lock Nut Adjusting Nut

### 3. INSPECTION/ADJUSTMENT

---

\* Reference tip alignment within 1mm of index mark on open side is acceptable. However, the aligning mark on the control lever must never be on the closed side of the index mark, otherwise engine damage will occur because of insufficient lubrication.

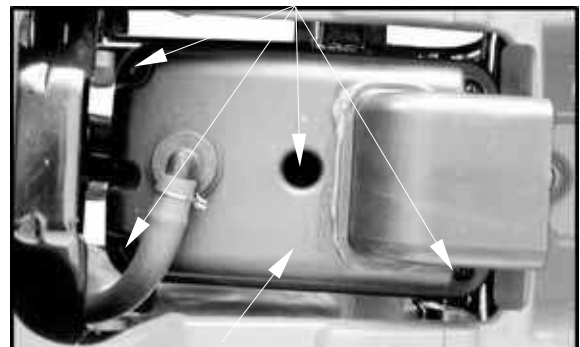

r

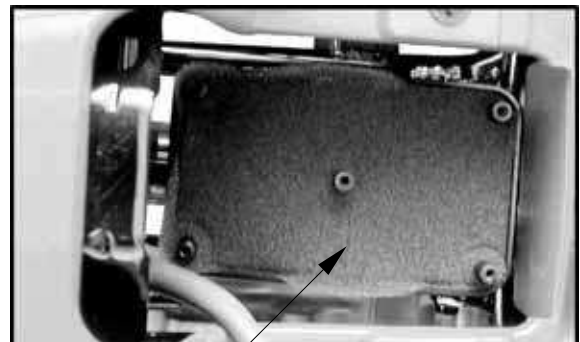

Air Filter Element



### 3. INSPECTION/ADJUSTMENT

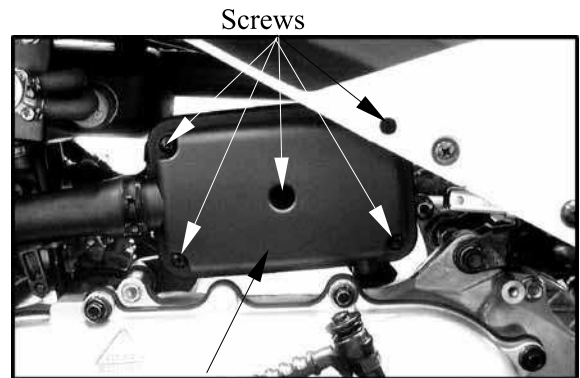

Air Filter Case Cover

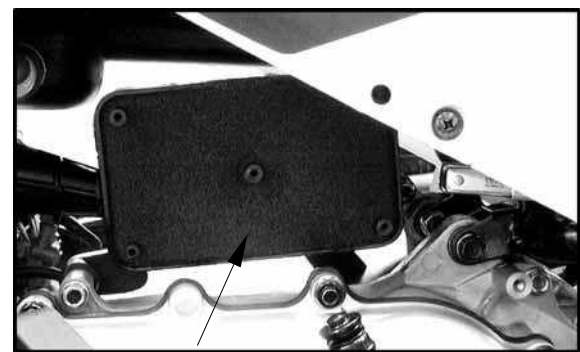

Air Filter Element

\* Do not use gasoline or low flash point solvents which may lead to a fire or explosion.

\* Do not twist or wring out the foam element. This could damage the foam material.

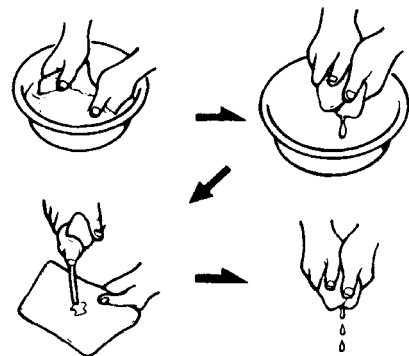

\* The element should be wet but not dripping.

### 3. INSPECTION/ADJUSTMENT

#### SPARK PLUG

Remove the ignition coil cap and spark plug.  
 Check the spark plug for wear and fouling deposits.  
 Clean any fouling deposits with a spark plug cleaner or a wire brush.

#### Specified Spark Plug:

(Mongoose/KXR 90): NGK: C7HSA  
 (Mongoose/KXR 50): NGK: BR8HAS



Ignition Coil Cap/Spark Plug

Measure the spark plug gap.

**Spark Plug Gap:** 0.6~0.7mm

\* When installing, first screw in the spark plug by hand and then tighten it with a spark plug wrench.

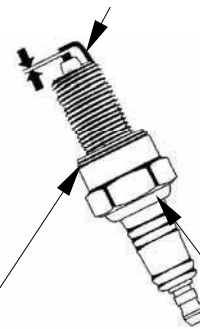

Washer Deformation

Cracks, Damage

#### CYLINDER COMPRESSION

Warm up the engine before compression test.

Remove the spark plug.

Insert a compression gauge.

Open the throttle valve fully and push the starter button to test the compression.

#### Compression:

(Mongoose/KXR 90): 16kg/cm<sup>2</sup>

(Mongoose/KXR 50): 12kg/cm<sup>2</sup>

If the compression is low, check for the following:

- Leaky valves
- Valve clearance too small
- Leaking cylinder head gasket
- Worn piston rings
- Worn piston/cylinder

If the compression is high, it indicates that carbon deposits have accumulated on the combustion chamber and the piston head.



Compression Gauge

### 3. INSPECTION/ADJUSTMENT

\*

Cylinder Head Cover

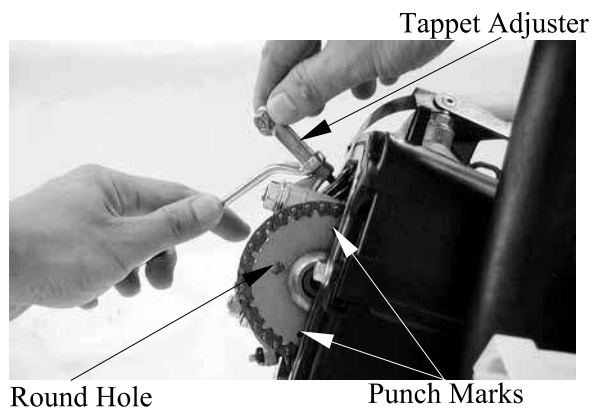
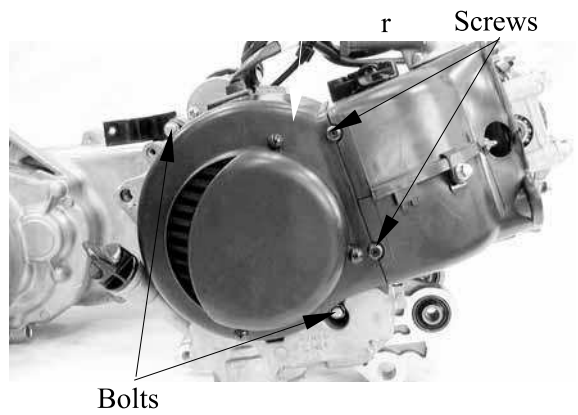

\* • Check the valve clearance again after the lock nut is tightened.

\* • The engine must be warm for accurate idle speed inspection and adjustment.



### 3. INSPECTION/ADJUSTMENT

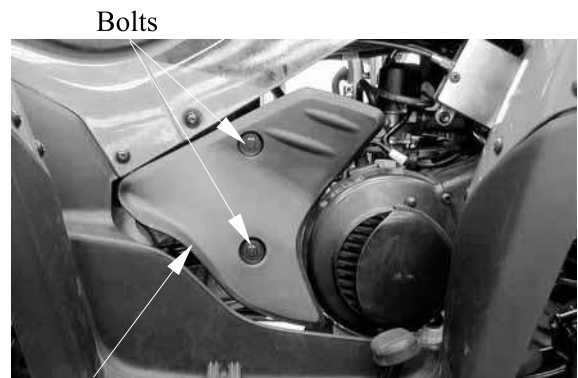

Bolts  
Right Side Cover

\* Run the engine for 2~3 minutes and check the oil level after the engine is stopped for 2~3 minutes.

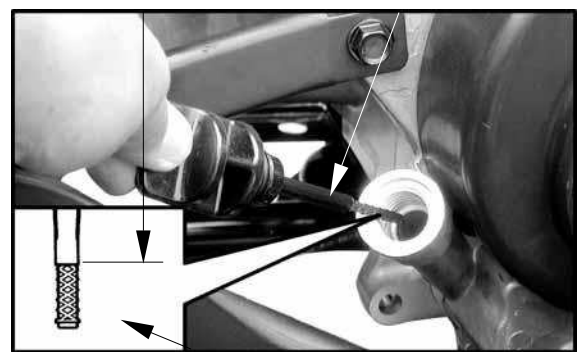

Minimum Level Mark

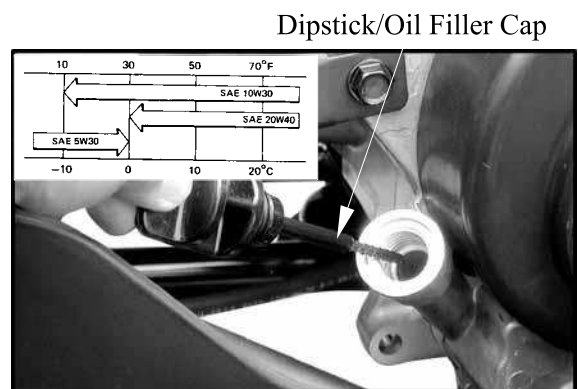

Dipstick/Oil Filler Cap

\* Be sure no foreign material enters the crankcase.

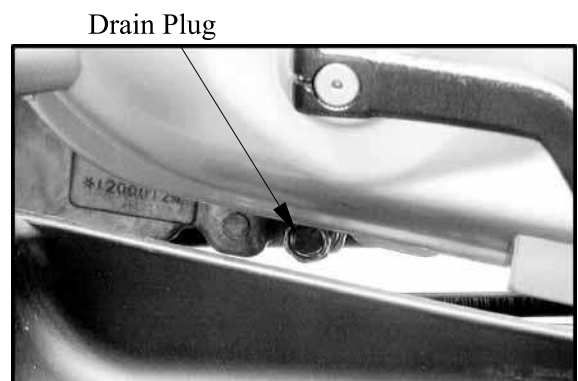

Drain Plug

### 3. INSPECTION/ADJUSTMENT

---

\*



\* Before reinstalling the drain plug, be sure to install the O-ring, compression spring and oil strainer.

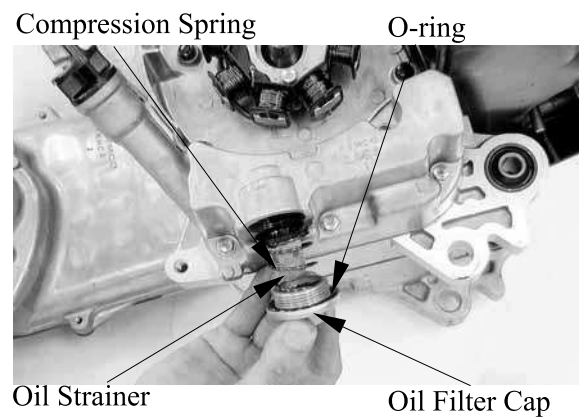

### 3. INSPECTION/ADJUSTMENT

---



Drain Plug

\* Be sure no foreign material enters the crankcase.

### 3. INSPECTION/ADJUSTMENT

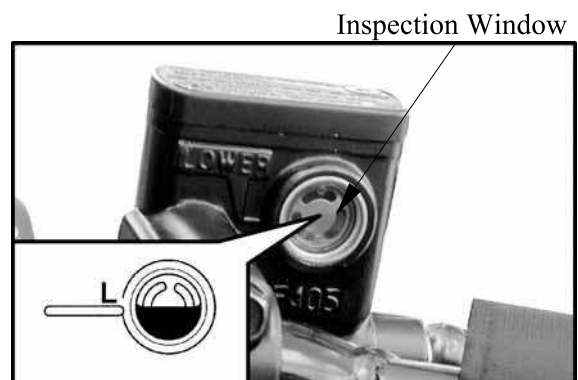
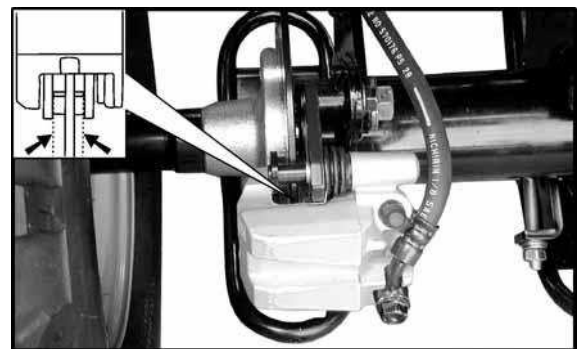
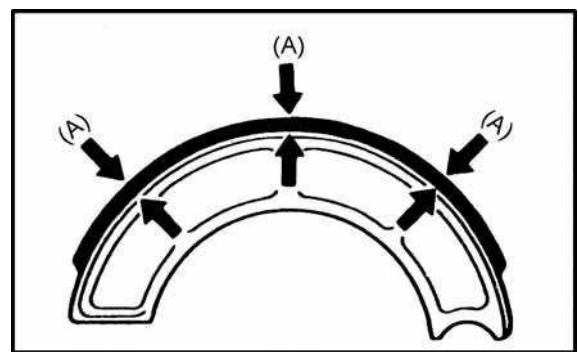
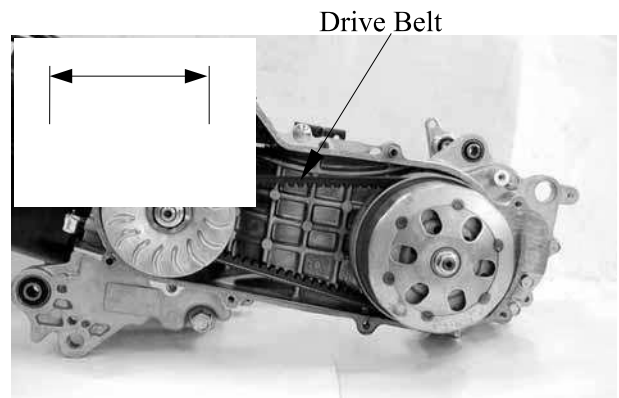

### 3. INSPECTION/ADJUSTMENT

---

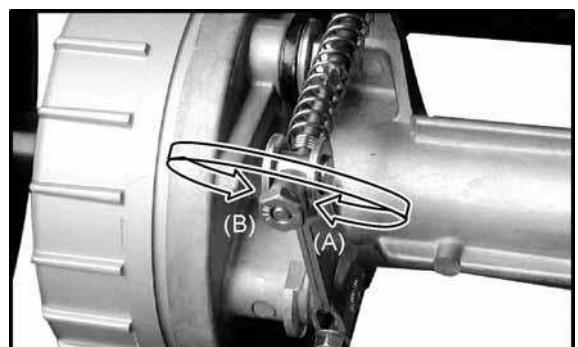
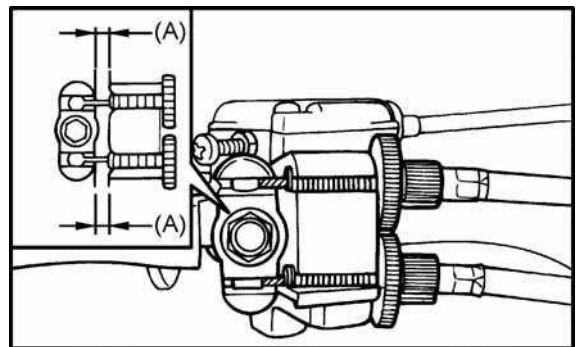
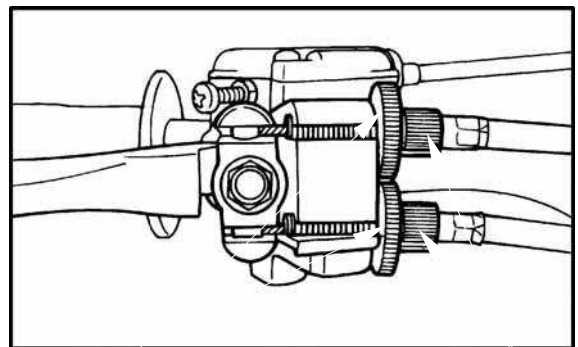
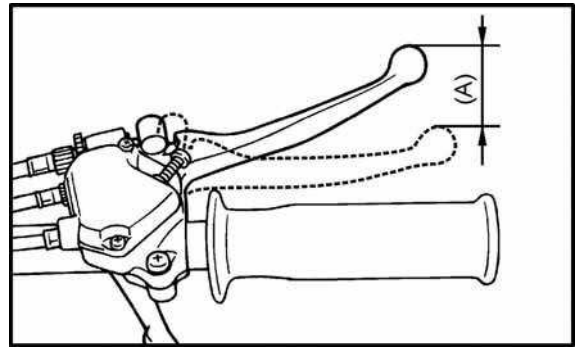



### 3. INSPECTION/ADJUSTMENT

\*

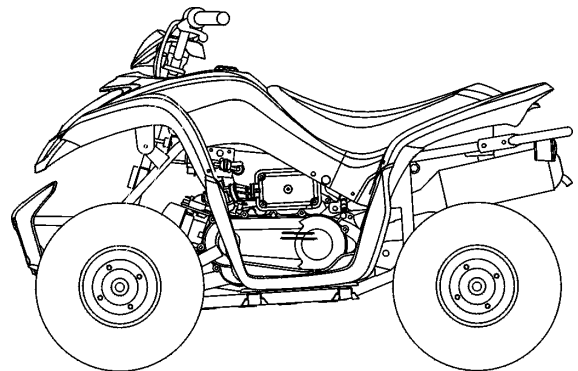
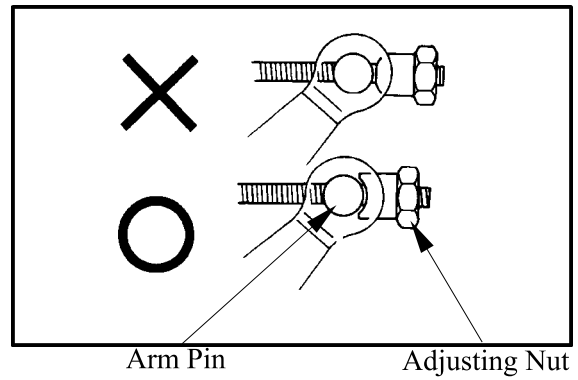

### 3. INSPECTION/ADJUSTMENT

---

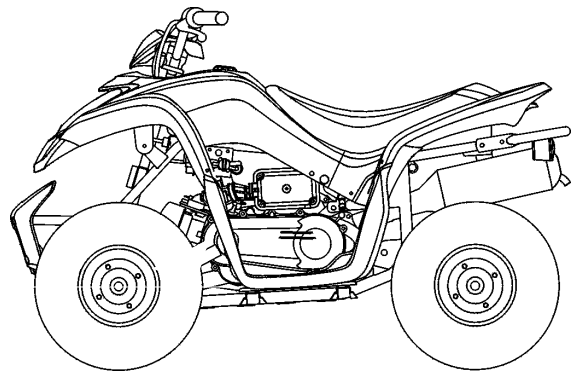
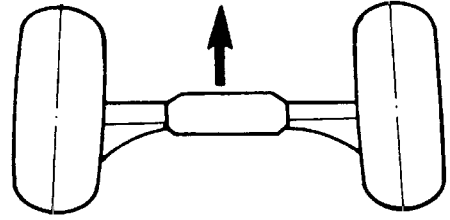

\*



### 3. INSPECTION/ADJUSTMENT

\* Tire pressure should be checked when tires are cold.

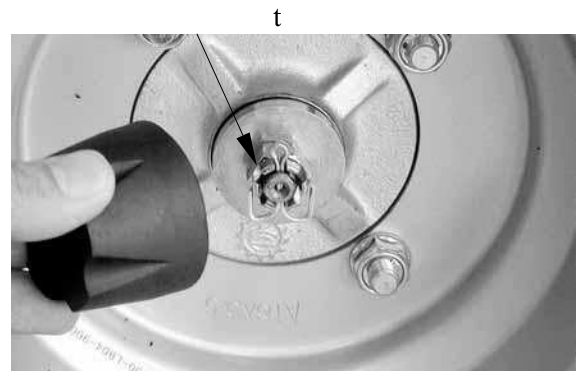
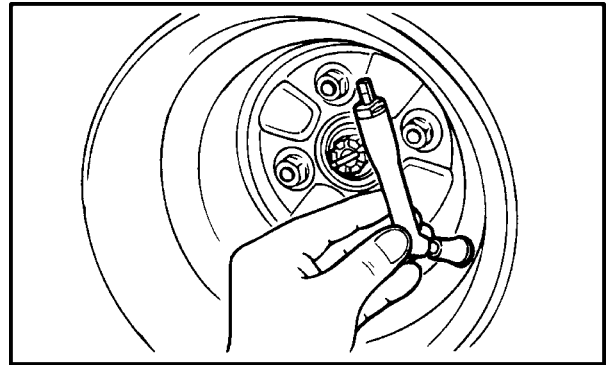

Rear Axle Nut



\*

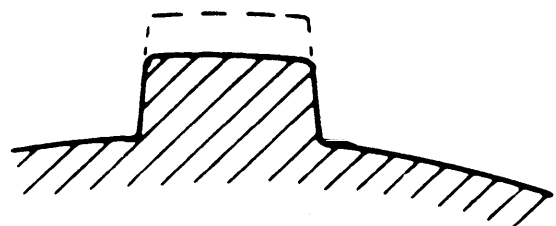

### 3. INSPECTION/ADJUSTMENT

- \*
  - Never attempt even small repairs to the wheel.
  - Ride conservatively after installing a tire to allow it to seat itself properly on the rim.

- \* Too little of chain slack will overload the engine and other vital parts; keep the slack within the specified limits.

- \* Wheels should be on the ground without the rider on it.

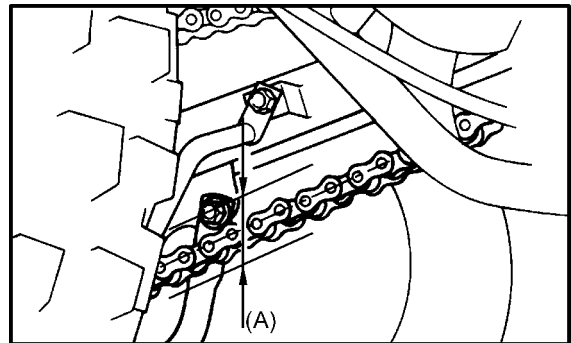

- \* Support the machine securely so there is no danger of it falling over.

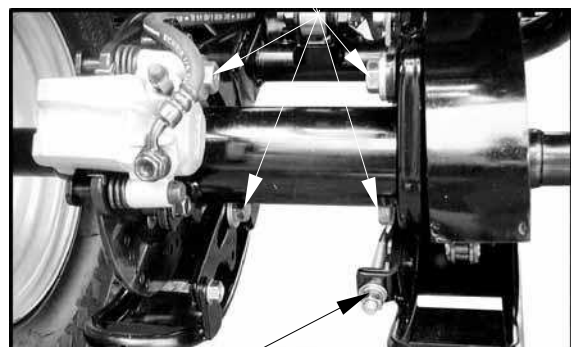

Hub Stopper Nut

### 3. INSPECTION/ADJUSTMENT

---

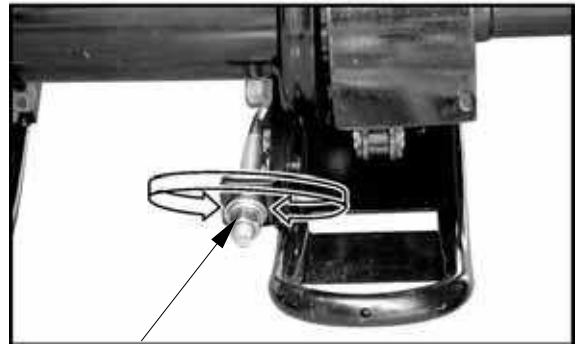

Lighting Nut

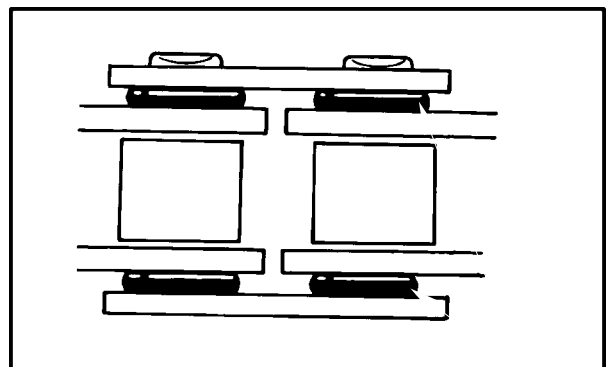

### 3. INSPECTION/ADJUSTMENT

---

\* Damaged cable sheath may cause corrosion and interfere with the cable movement. An unsafe condition may result so replace such cable as soon as possible.

\* Hold cable end high and apply several drops of lubricant to cable.

\* Wipe off the excess grease.

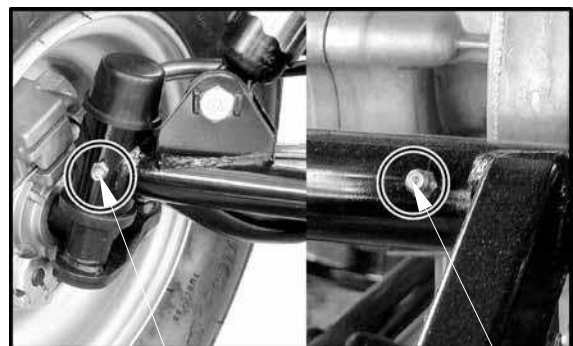

Rear Swing  
Arm Nipple

### 3. INSPECTION/ADJUSTMENT

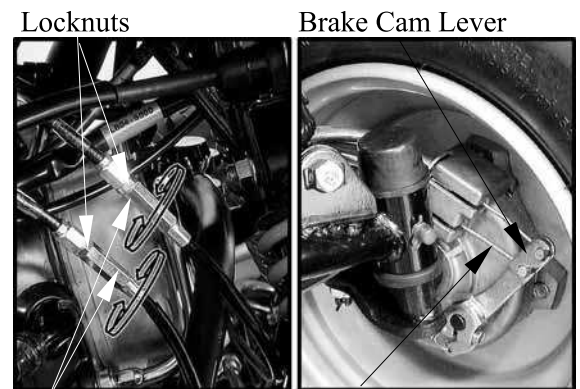
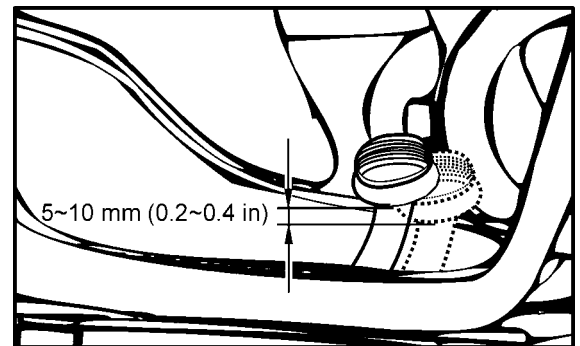
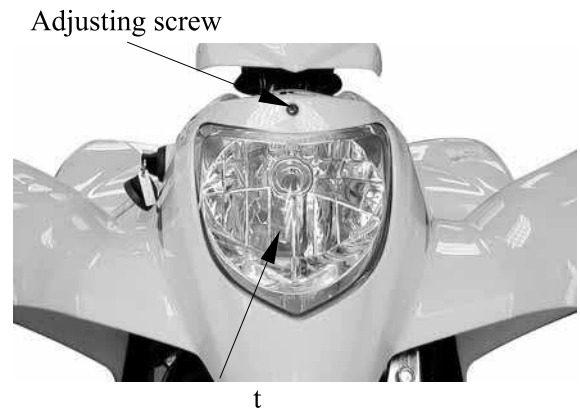

R/L Front Lower Cable

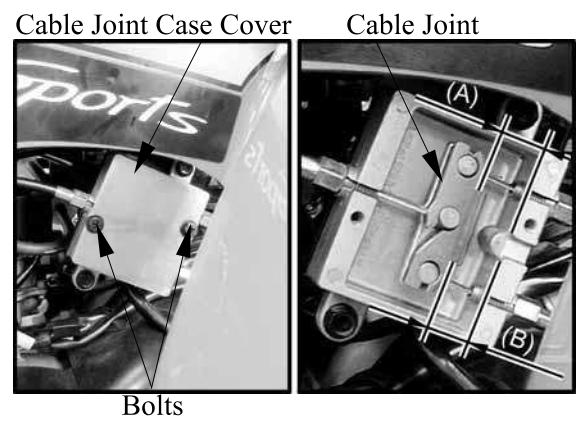

### 3. INSPECTION/ADJUSTMENT

Brake Pedal Cable

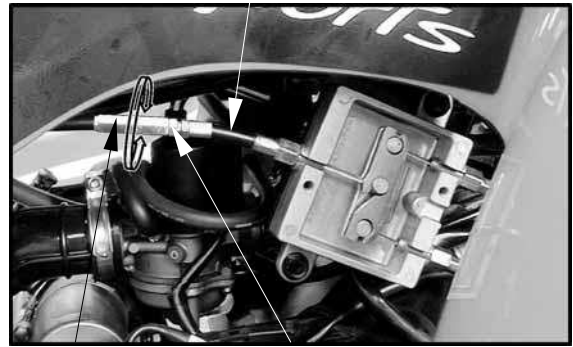

Adjusting Blot

Locknut

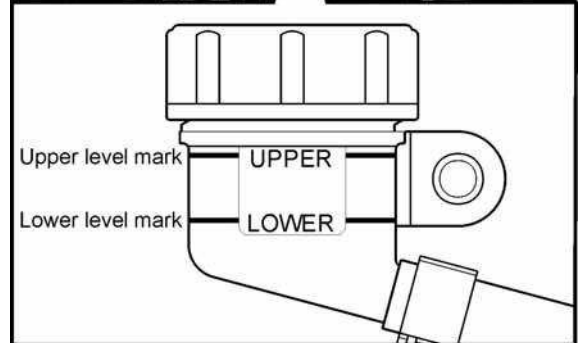



## 4. LUBRICATION SYSTEM

---

---

---

---

---

---

---

---

### LUBRICATION SYSTEM

---

SERVICE INFORMATION (Mongoose/KXR 90) -----	4- 3
SERVICE INFORMATION (Mongoose/KXR 50) -----	4- 4
ENGINE OIL/OIL FILTER (Mongoose/KXR 90)-----	4- 5
OIL PUMP BLEEDING (Mongoose/KXR 50)-----	4- 9
OIL TANK (Mongoose/KXR 50) -----	4-10
OIL PUMP (Mongoose/KXR 50)-----	4-11
OIL FILTER CLEANING (Mongoose/KXR 50)-----	4-12

# 4. LUBRICATION SYSTEM

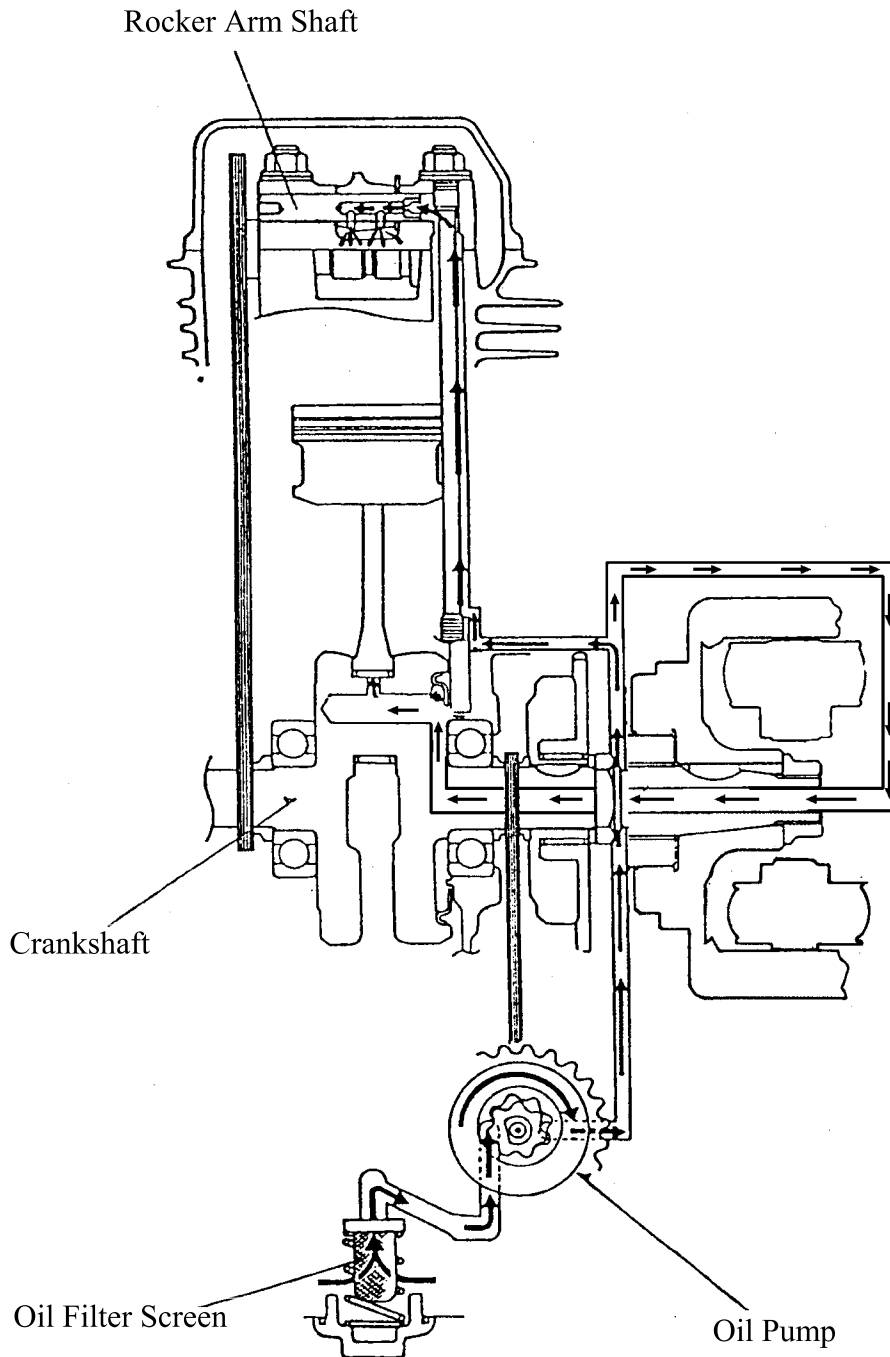

## 4. LUBRICATION SYSTEM

### LUBRICATION SYSTEM (Mongoose/KXR 50)

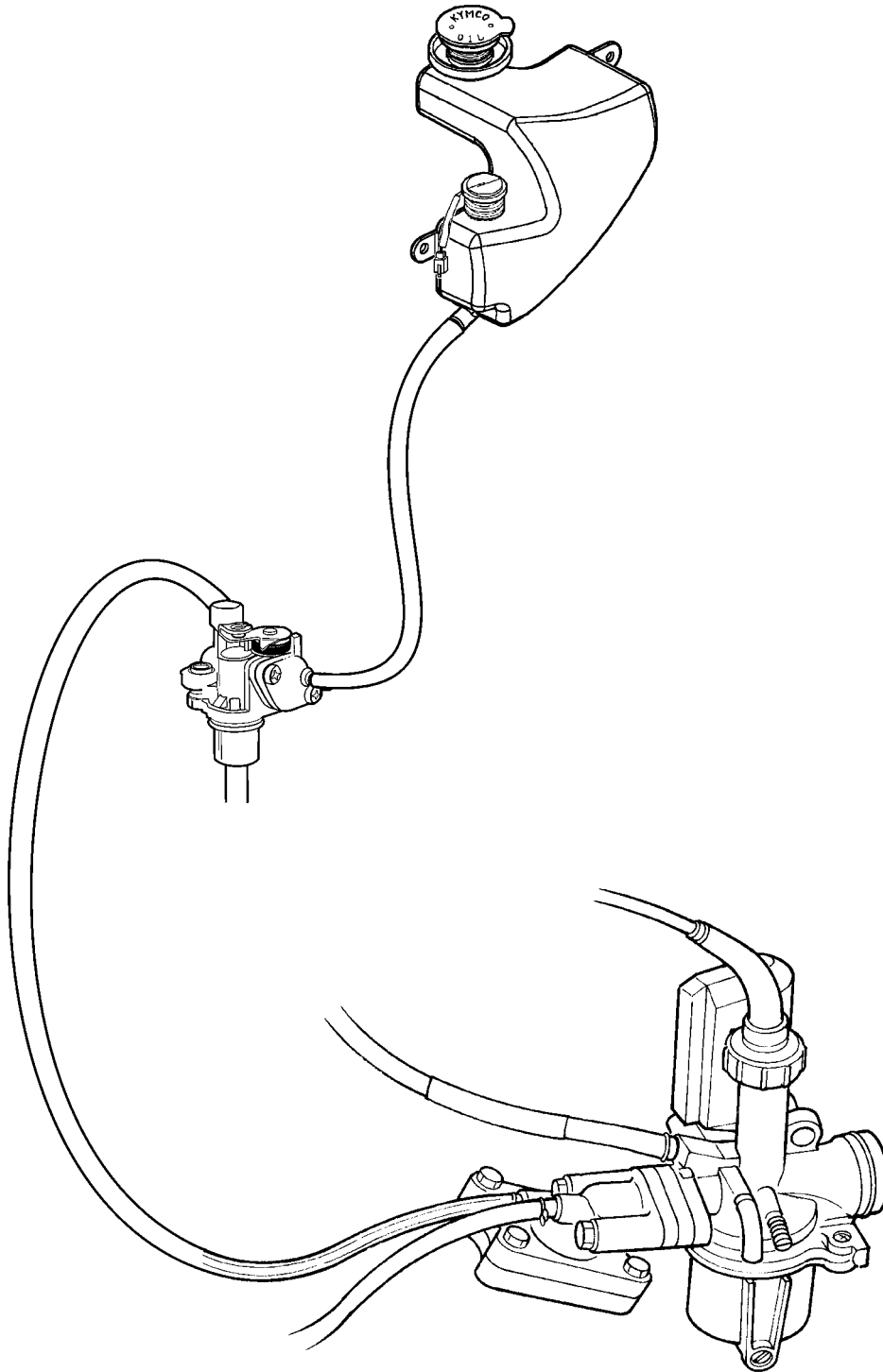

## 4. LUBRICATION SYSTEM

### SERVICE INFORMATION (Mongoose/KXR 90)

#### GENERAL INSTRUCTIONS

- The maintenance of lubrication system can be performed with the engine installed in the frame.
- Use care when removing and installing the oil pump not to allow dust and foreign matters to enter the engine and oil line.
- Do not attempt to disassemble the oil pump. The oil pump must be replaced as a set when it reaches its service limit.
- After the oil pump is installed, check each part for oil leaks.

#### SPECIFICATIONS

Item		Standard (mm)	Service Limit (mm)
Oil pump	Inner rotor-to-outer rotor clearance	0.15	0.20
	Outer rotor-to-pump body clearance	0.15~0.20	0.25
	Rotor end-to-pump body clearance	0.04~0.09	0.12

#### TROUBLESHOOTING

##### Oil level too low

- Natural oil consumption
- Oil leaks
- Worn or poorly installed piston rings
- Worn valve guide or seal

##### Poor lubrication pressure

- Oil level too low
- Clogged oil filter or oil passages
- Not use the specified oil

## 4. LUBRICATION SYSTEM

---

### SERVICE INFORMATION (Mongoose/KXR 50)

#### GENERAL INSTRUCTIONS

- Use care when removing and installing the oil pump not to allow dust and dirt to enter the engine and oil line.
- Do not attempt to disassemble the oil pump.
- Bleed air from the oil pump if there is air between the oil pump and oil line.
- If the oil is disconnected, refill the oil line with motor oil before connecting it.

#### SPECIFICATIONS

- Recommended Motor Oil: SAE20W20# 2-stroke Motor Oil
- Oil Capacity : 1.0 liter
- Light comes on : 0.25 liter

#### TROUBLESHOOTING

##### **Excessive white smoke or carbon deposits on spark plug**

- Oil pump not properly synchronized (excessive oil)
- Poor quality oil

##### **Engine overheating**

- Oil pump not properly adjusted (insufficient oiling)
- Poor quality oil

##### **Seized piston**

- No oil in tank or clogged oil line
- Oil pump not properly adjusted (insufficient oiling)
- Air in oil line
- Faulty oil pump

##### **Oil not flowing out of tank to engine**

- Clogged oil tank cap breather hole
- Clogged oil filter

## 4. LUBRICATION SYSTEM

### ENGINE OIL/OIL FILTER (Mongoose/KXR 90)

#### OIL LEVEL AND OIL CHANGE

Refer to the “ENGINE OIL” section in the chapter 3 to check the oil level and replacement and oil filter cleaning.

### OIL PUMP

#### REMOVAL

Place a container under the engine.

Remove the drain plug to drain the oil. (⇒3-9)

Remove the A.C. generator flywheel. (⇒14-8)

Remove the A.C. generator stator and pulsar coil. (⇒14-8)

Remove the eight right crankcase cover bolts and the right crankcase cover.

Remove the two bolts and oil separator cover.

Remove the oil pump driven gear nut.  
Remove the oil pump driven gear and drive chain.

Right Crankcase Cover

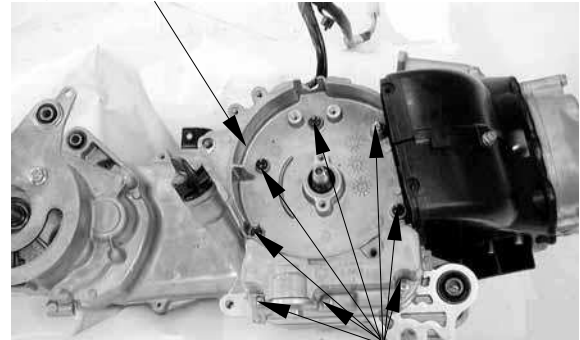

Bolts

Bolts



Oil Separator Cover

Oil Pump Driven Gear

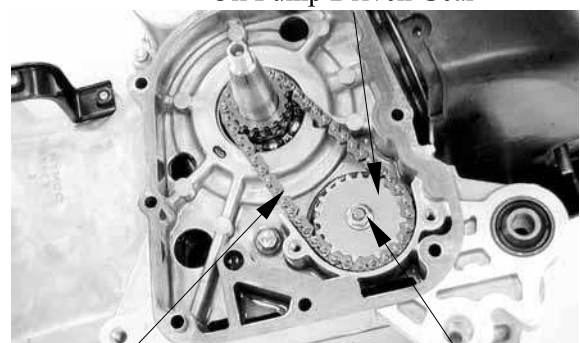

Drive Chain

Nut

## 4. LUBRICATION SYSTEM

Remove the two oil pump mounting bolts and the oil pump.

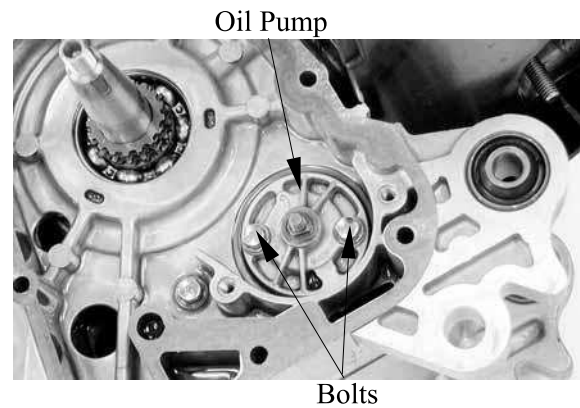

### DISASSEMBLY

Remove the screw and disassemble the oil pump.

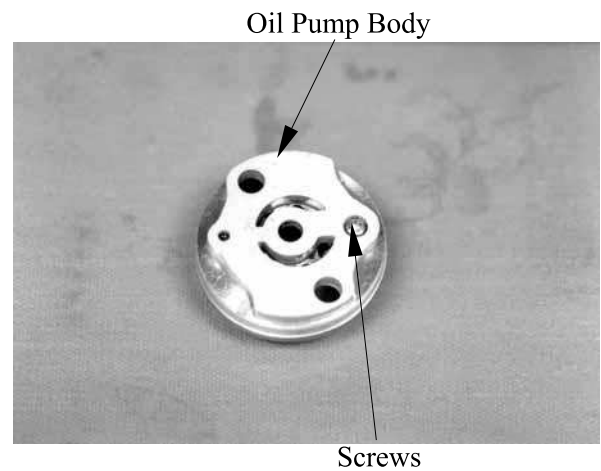

### INSPECTION

Measure the pump body-to-outer rotor clearance.

**Service Limit:** 0.25mm

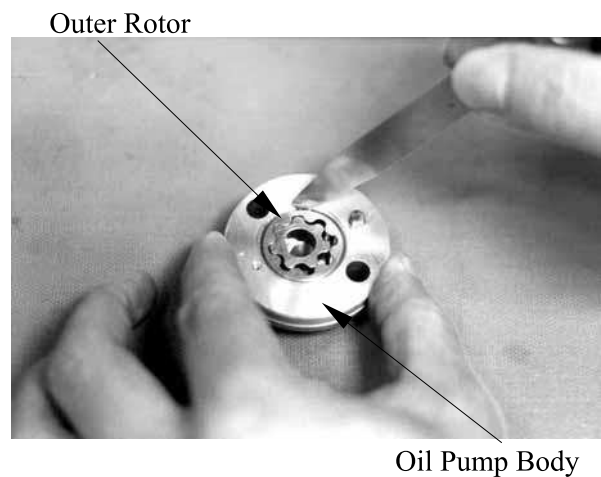

## 4. LUBRICATION SYSTEM

Measure the inner rotor-to-outer rotor clearance.

**Service Limit:** 0.2mm

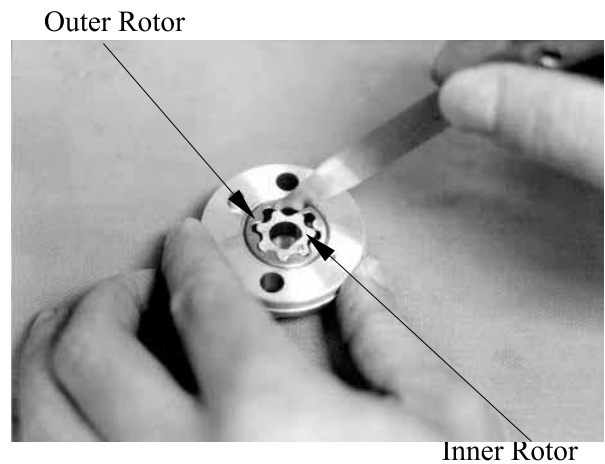

Measure the rotor end-to-pump body clearance.

**Service Limit:** 0.12mm



### ASSEMBLY

Install the outer rotor, inner rotor and pump shaft into the pump body.

Insert the pump shaft by aligning the flat on the shaft with the flat in the inner rotor.

Install the dowel pin.

Install the pump cover by aligning the hole in the cover with the dowel pin.

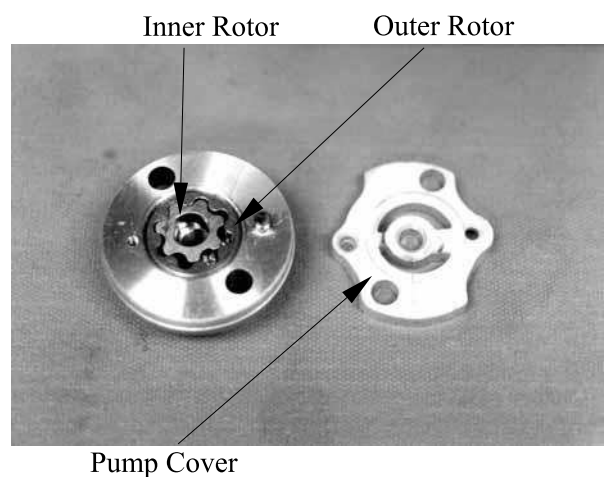



## 4. LUBRICATION SYSTEM

Tighten the screw to secure the pump cover.  
Make sure that the pump shaft rotates freely  
without binding.

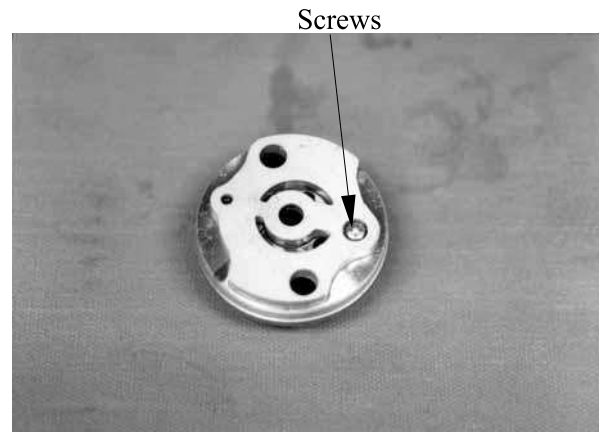

### INSTALLATION

Reverse the “OIL PUMP REMOVAL”  
procedures.

Make sure that the pump shaft rotates freely  
without binding.

Install the oil pump with the arrow on  
the pump body facing up and fill the oil  
pump with engine oil before installation.



Oil Pump



## 4. LUBRICATION SYSTEM

### OIL PUMP BLEEDING (Mongoose/KXR 50)

\*

- Air in the oil tubes will block oil flow and result in severe engine damage.
- Bleed air from the oil tubes and oil pump whenever the oil tubes or pump have been removed or there is air in the oil tubes.

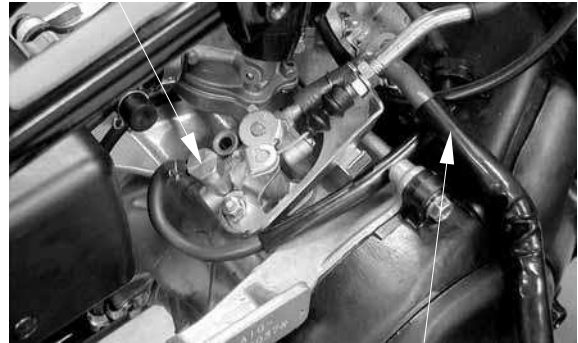

### OIL INLET LINE/OIL PUMP BLEEDING

Fill the oil tank with recommended oil.  
Place a shop towel around the oil pump.  
Disconnect the oil inlet tube from the oil pump and clip it.  
Fill the oil pump with oil by squirting clean oil through the joint. (About 3cc)  
Fill the oil line with oil and connect it to the oil pump.

\*

Bleed air from the oil inlet tube first, then bleed air from the oil outlet line.

### OIL OUTLET LINE BLEEDING

1. Disconnect the oil outlet tube and bend it into U shape. Force air out of the tube by filling it with oil.
2. Start the engine and allow it to idle with the oil control lever in the fully open position. Visually check the oil flow.
3. If there is no oil flowing out within 1 minute, bleed air from the oil inlet tube and oil pump.

\*

- Never run the engine in a closed area.
- Do not increase the engine speed at will.

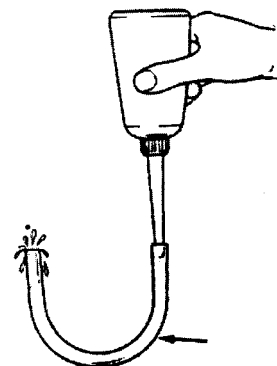

## 4. LUBRICATION SYSTEM

### OIL TANK (Mongoose/KXR 50)

#### OIL TANK REMOVAL

Remove the oil level switch connector.  
Remove the two bolts attaching the oil tank.

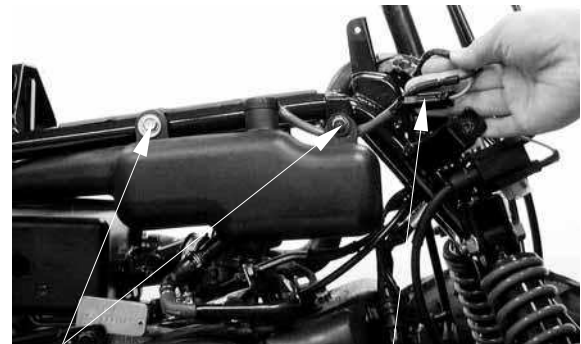

Bolts

Oil Level Switch Connector

Oil Inlet Tube

Disconnect the oil inlet tube.  
Drain the oil inside the oil tank into a clean container.  
Remove the oil tank.  
The installation sequence is the reverse of removal.



\*

- Connect the oil tube properly.
- Bleed air from the oil pump after installation. (See page 4-9)
- The oil tube clip (at the oil tank side) must be locked from inside of the oil tube joint.

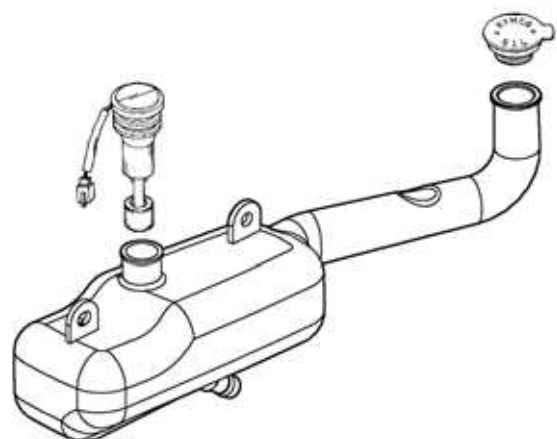

## 4. LUBRICATION SYSTEM

### OIL PUMP (Mongoose/KXR 50)

#### REMOVAL

\* Do not allow foreign matters to enter the crankcase. Before removing the oil pump, clean the oil pump and crankcase surfaces.

Disconnect the oil outlet tube from the oil pump.

Disconnect the oil pump control cable from the pump body.  
Disconnect the oil inlet tube.

\* Before disconnecting the oil line, clip the oil line to avoid oil flowing out and then plug the oil line after it is disconnected.

Remove the oil pump control cable plate bolts.  
Remove the oil pump from the crankcase.

#### OIL PUMP INSPECTION

Remove the oil pump and inspect the following items:

- Weakened O-ring
- Damage to crankcase mating surface
- Damage to pump body
- Control lever operation
- Oil leaks through oil seals
- Worn or damaged pump pinion

\* Do not disassemble the oil pump which cannot be used after disassembly.

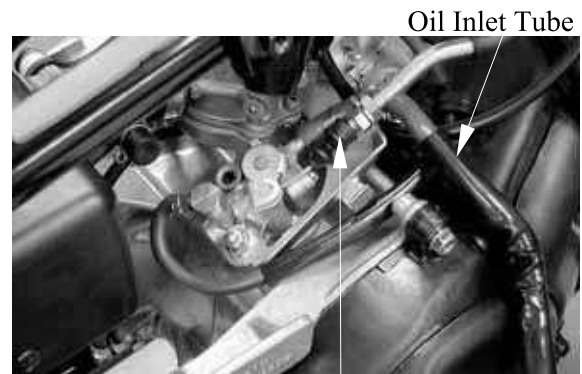

Oil Pump Control Cable

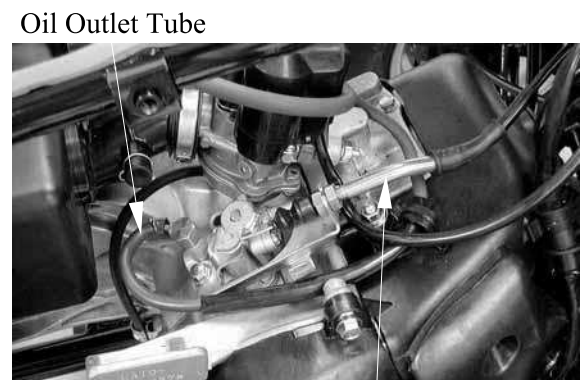

Oil Outlet Tube

Oil Pump Control Cable



Bolts

Oil Pump

Oil Pump Control Cable Plate

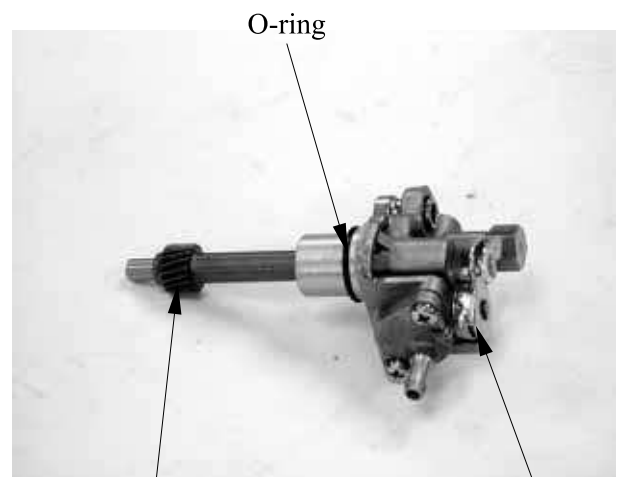

O-ring

Gear

Control Lever

## 4. LUBRICATION SYSTEM

### OIL PUMP INSTALLATION

\*

- Lubricate the O-ring with grease or engine oil before installation.
- Make sure that the oil pump is inserted into the crankcase.
- Apply molybdenum disulfide or grease to the pump pinion.

Install the oil pump into the crankcase.  
 Install the oil pump control cable plate.  
 Connect the oil inlet line and oil outlet tube properly.  
 Connect the oil pump control cable.  
 Bleed air from the oil pump. (See page 4-9)

\*

- Connect the oil tube properly.
- Bleed air from the oil pump after installation.
- The oil tube clip (at the oil tank side) must be locked from inside of the oil tube joint.



Grease or Engine Oil

### OIL FILTER CLEANING (Mongoose/KXR 50)

Disconnect the oil tube at the oil pump side and allow oil to drain into a clean container.  
 Remove the tube clip at the oil tank side and disconnect the oil tube.  
 Remove the oil filter.

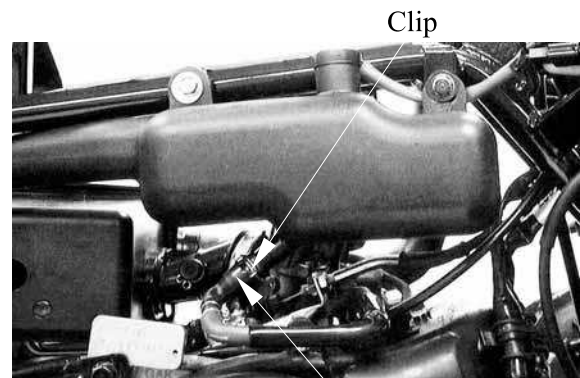

r

Clean the oil filter screen with compressed air.

Install the oil filter in the reverse order of removal and fill the oil tank with specified oil up to the proper level.  
 Bleed air from the oil pump and oil lines.

\*

- Connect the oil tubes securely.
- Install the tube clip at the oil tank side and also install the clip to the lower oil tube that goes to the oil pump.
- Check for oil leaks.

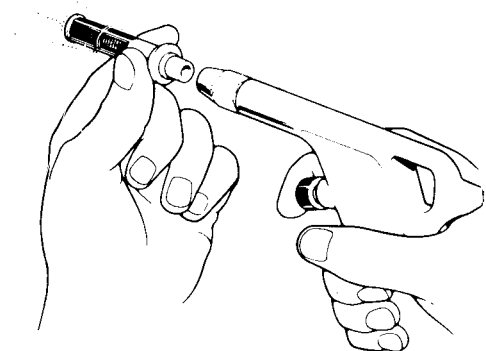

# 5. FUEL SYSTEM

---

---

## FUEL SYSTEM

---

SERVICE INFORMATION-----	5- 2
FUEL TANK -----	5- 4
FUEL VALVE REMOVAL -----	5- 4
THROTTLE VALVE-----	5- 7
AIR CLEANER -----	5- 9
CARBURETOR-----	5-11
REED VAVLE (Mongoose/KXR 50)-----	5-16

## 5. FUEL SYSTEM

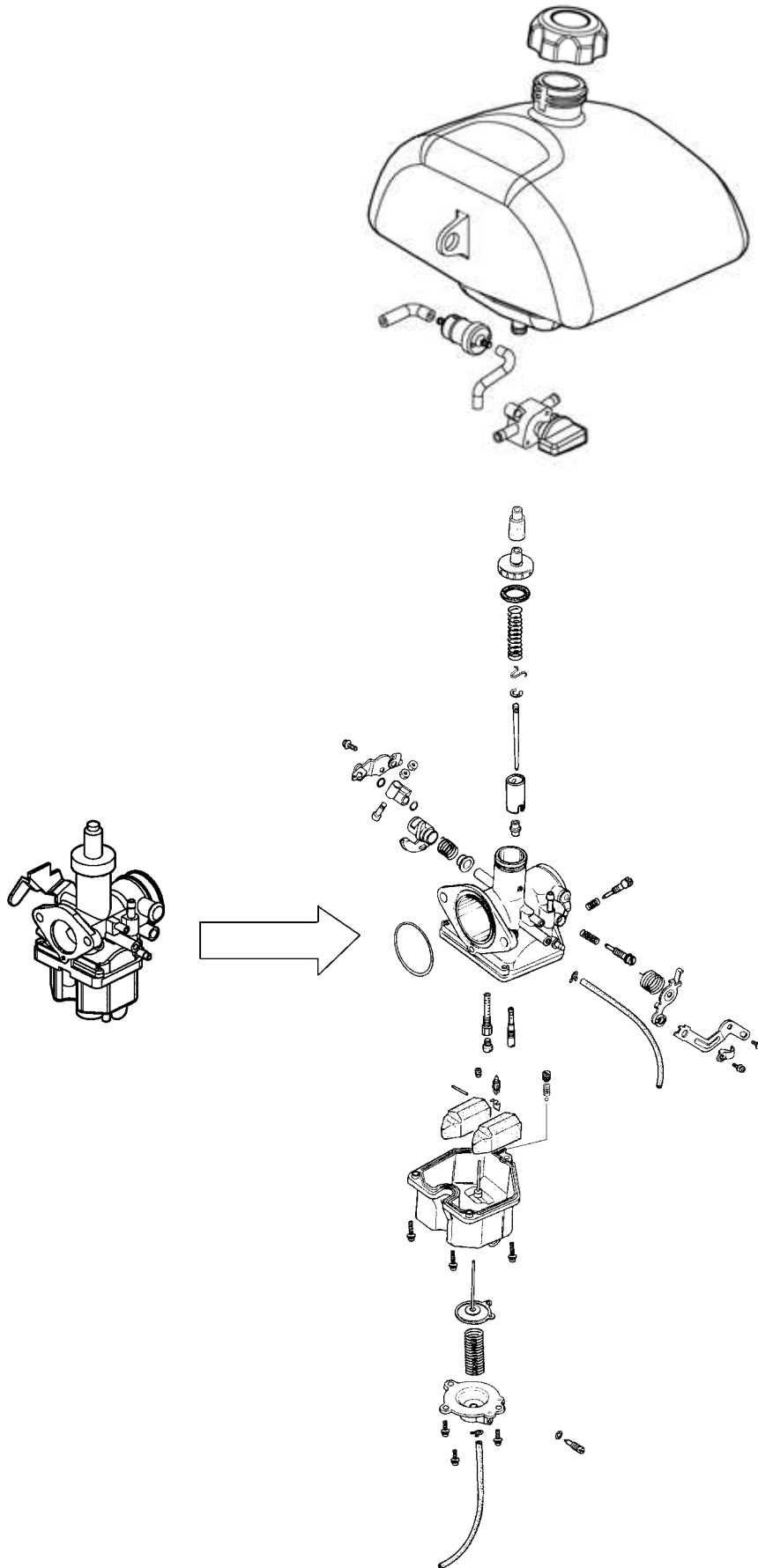

## 5. FUEL SYSTEM

### SERVICE INFORMATION

#### GENERAL INSTRUCTIONS



Gasoline is very dangerous. When working with gasoline, keep sparks and flames away from the working area.  
Gasoline is extremely flammable and is explosive under certain conditions. Be sure to work in a well-ventilated area.

- Do not bend or twist control cables. Damaged control cables will not operate smoothly.
- When disassembling fuel system parts, note the locations of O-rings. Replace them with new ones during reassembly.
- Before float chamber disassembly, loosen the drain screw to drain the residual gasoline into a clean container.
- After the carburetor is removed, plug the intake manifold side with a clean shop towel to prevent foreign matters from entering.
- When cleaning the carburetor air and fuel jets, the O-rings and diaphragm must be removed first to avoid damage. Then, clean with compressed air.
- When the machine is not used for over one month, drain the residual gasoline from the float chamber to avoid erratic idling and clogged slow jet due to deteriorated fuel.

#### SPECIFICATIONS

Item	Standard(Mongoose/KXR 90)	Standard(Mongoose/KXR 50)
Type	PB	PB
Venturi dia.	φ14	φ14
Slow jet No.	#35	#38
Main jet No.	#100	#80
Adjust method	Piston	Piston
Idle speed	1700±100rpm	2000±100rpm
Throttle grip free play	1 ~ 4mm	1 ~ 4mm
Float level	8.0mm	8.0mm
Air screw opening	1±1/4	1±1/4



## **5. FUEL SYSTEM**

### **SPECIAL TOOL**

Float level gauge

### **TROUBLESHOOTING**

#### **Engine cranks but won't start**

- No fuel in tank
- No fuel to carburetor
- Cylinder flooded with fuel
- No spark at plug
- Clogged air cleaner
- Intake air leak
- Improper throttle operation

#### **Engine idles roughly, stalls or runs poorly**

- Faulty auto bystarter
- Ignition malfunction
- Faulty carburetor
- Poor quality fuel
- Lean or rich mixture
- Incorrect idle speed

#### **Misfiring during acceleration**

- Faulty ignition system
- Faulty carburetor

#### **Backfiring at deceleration**

- Float level too low
- Incorrectly adjusted carburetor
- Faulty exhaust muffler

#### **Engine lacks power**

- Clogged air cleaner
- Faulty carburetor
- Faulty ignition system

#### **Lean mixture**

- Clogged carburetor fuel jets
- Float level too low
- Intake air leak
- Clogged fuel tank cap breather hole
- Bent, kinked or restricted fuel line

#### **Rich mixture**

- Float level too high
- Clogged air jets
- Clogged air cleaner

## 5. FUEL SYSTEM

### FUEL TANK

#### REMOVAL



- Keep sparks and flames away from the work area.
- Wipe off any spilled gasoline.

Remove front fender (See page 2-5).

Switch the fuel valve “OFF”.  
 Disconnect the fuel outlet tube from fuel valve.  
 Remove two screws attaching the fuel valve and holder.

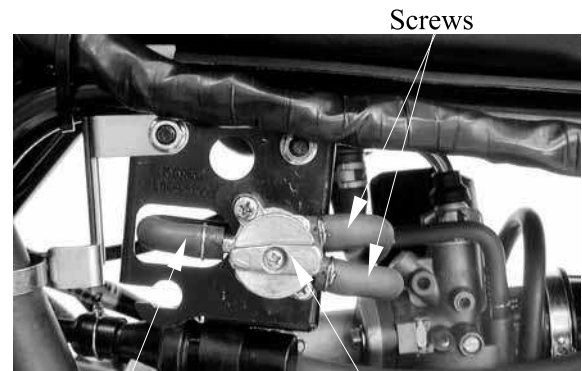

Remove the two bolts and then remove the fuel tank.

#### INSTALLATION

Reverse the “FUEL TANK REMOVAL” procedures.

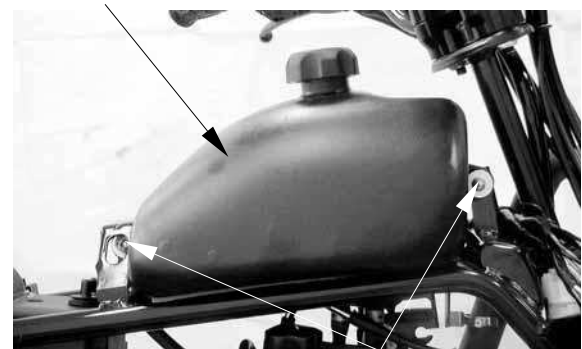

### FUEL VALVE REMOVAL

- \* • Keep sparks and flames away from the work area.
- Drain gasoline into a clean container.

Remove the screw and then remove control switch.  
 Disconnect all fuel tubes and then remove fuel valve.

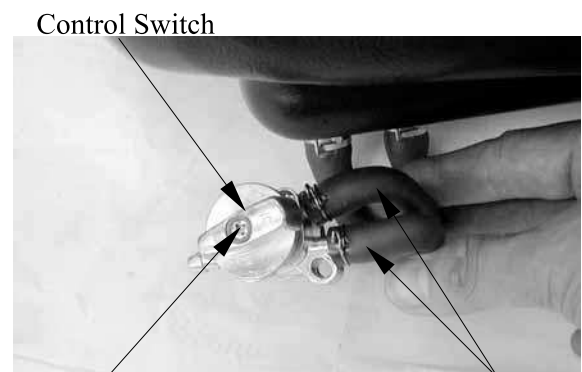

## 5. FUEL SYSTEM

### DISASSEMBLY

Remove the two screws on the retaining ring and then remove retaining ring. Remove the washer and control shaft.

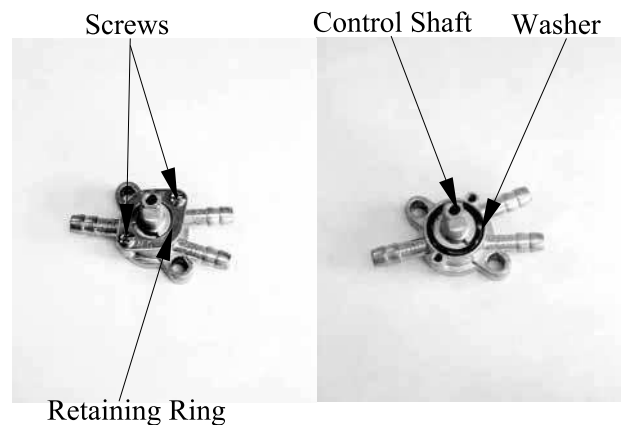

Remove the rubber gasket from the fuel valve body.

### INSPECTION

Inspect the fuel valve body for dirt and clog. Clean if necessary.

Replace the rubber gasket with new ones if they are damaged or deteriorated.

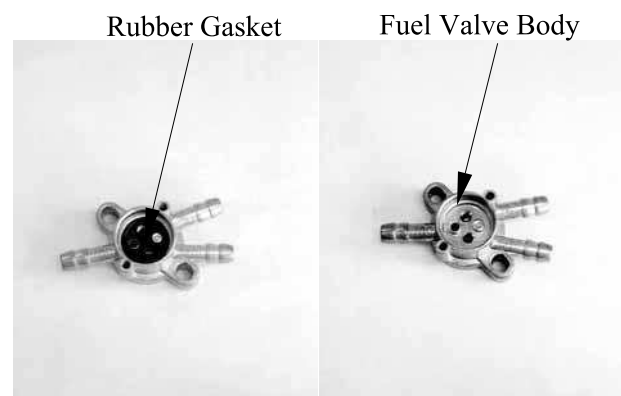

Replace the O-rings with new ones if they are damaged or deteriorated.

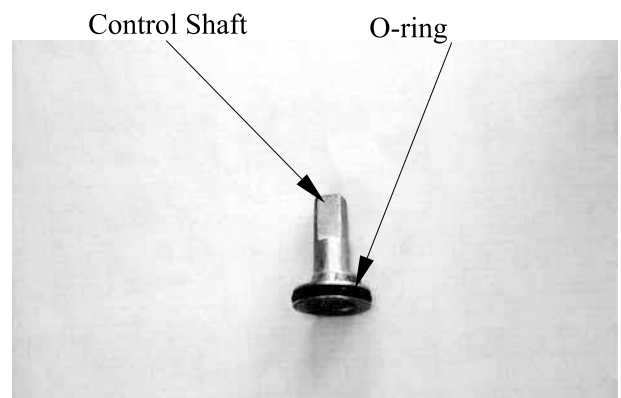

### ASSEMBLY

Reverse the "DISASSEMBLY" procedures. Install rubber gasket, control shaft, washer and retaining ring.

- \*
- Aligning the tab on the control shaft with the outlet duct in the fuel valve body.
  - Aligning the tab on the retaining ring with the outlet duct in the fuel valve body.

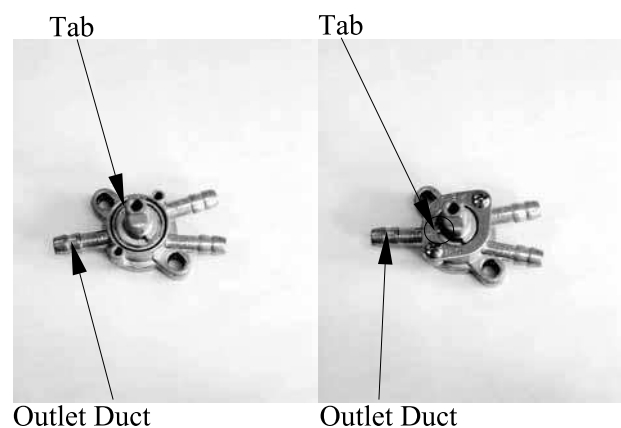

## 5. FUEL SYSTEM

---

### INSTALLATION

Reverse the “FUEL VALVE REMOVEAL”  
procedures.

Connect all fuel tube.

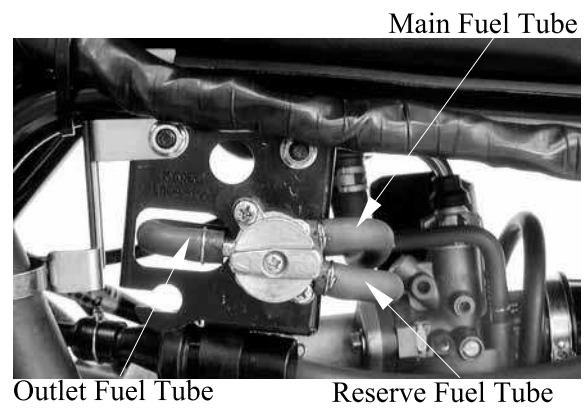

## 5. FUEL SYSTEM

### THROTTLE VALVE

#### DISASSEMBLY

Remove the fuel tank. (Refer to “FUEL TANK” section in the chapter 5)

Remove the carburetor cap.



Pull out the throttle valve.



Compress the spring to disconnect the throttle cable by hand.

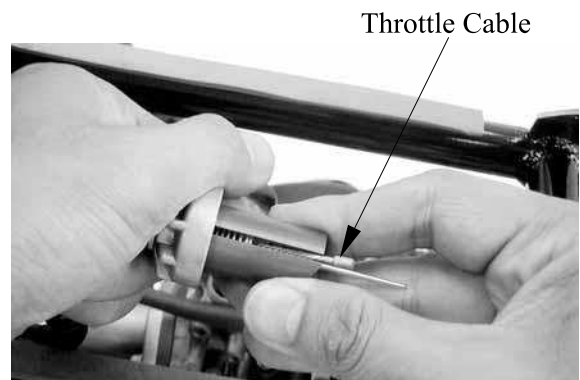

Remove the spring from the throttle valve



## 5. FUEL SYSTEM

Pry off the needle retainer and remove the jet needle.  
Check the throttle valve and jet needle for wear or damage.

### ASSEMBLY

Reverse the “DISASSEMBLY” procedures.

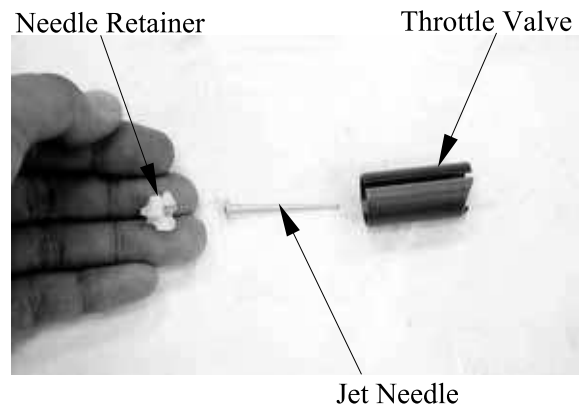

Install the throttle valve into the carburetor body.

\* Align the groove in the throttle valve with the throttle stop screw on the carburetor body.

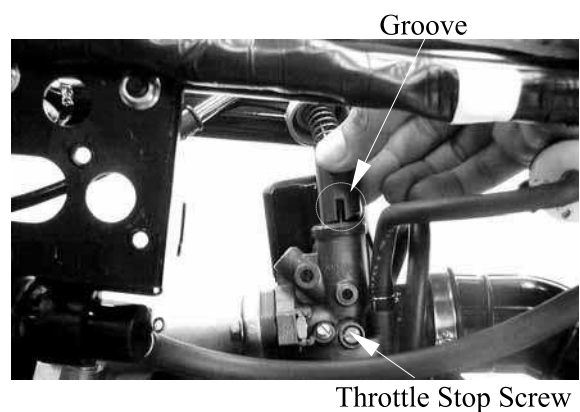

## 5. FUEL SYSTEM

### AIR CLEANER (Mongoose/KXR 90)

#### CLEANING

Refer to “AIR CLEANER” section in the chapter 3.

#### REMOVAL

Remove front fender. (See page 2-5)

Disconnect the oil recycle tube from cylinder head and frame.

Remove the bolt at the air cleaner left side.

Loosen the screw at the band and remove bolt at the air cleaner right side, then remove air cleaner.



Oil Recycle Tube

Bolt

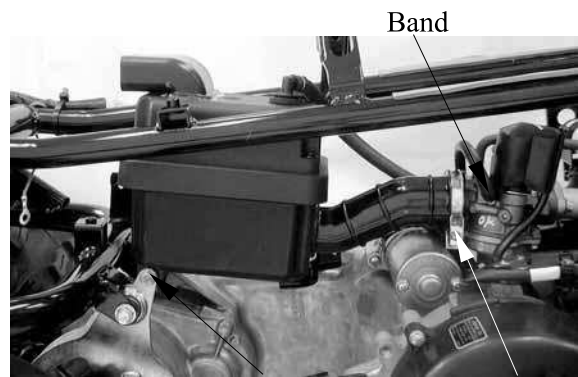

Band

Bolt

Screw

#### INSTALLATION

Reverse the “REMOVAL” procedures.



## 5. FUEL SYSTEM

### AIR CLEANER (Mongoose/KXR 50)

#### CLEANING

Refer to “AIR CLEANER” section in the chapter 3.

#### REMOVAL

Remove front fender. (See page 2-5)

Disconnect the air inlet hose from the frame.  
Remove the bolt at the air cleaner left side.

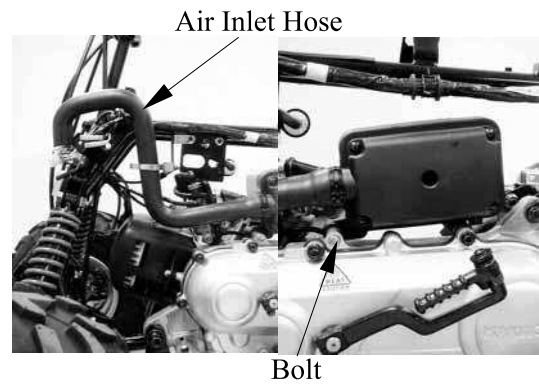

Loosen the screw at the band and remove bolt at the air cleaner right side, then remove air cleaner.

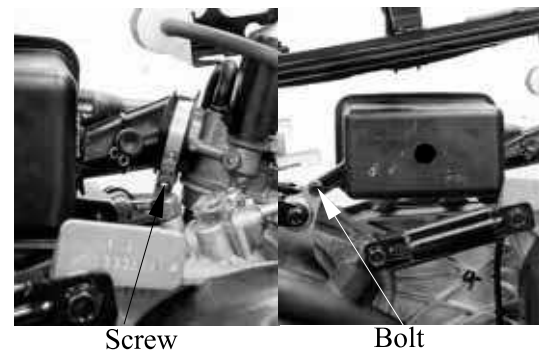

#### INSTALLATION

Reverse the “REMOVAL” procedures.



## 5. FUEL SYSTEM

### CARBURETOR

#### REMOVAL

Remove the fuel tank, carburetor cap and air filter. (Refer to chapter 5)

Loosen the drain plug to drain the gasoline from the float chamber.

- \* • Keep sparks and flames away from the work area.
- Drain gasoline into a clean container.



Fuel Drain Plug

Disconnect the fuel tube from carburetor and auto bystarter leads.

Remove the two bolts (nuts) attaching carburetor, then remove carburetor and insulator.

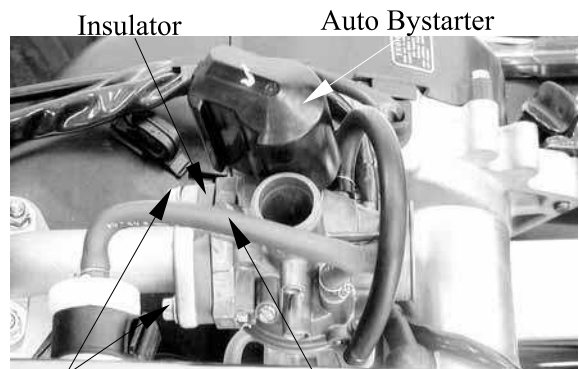

Insulator

Auto Bystarter

Bolts

Fuel Tube

#### INSTALLATION

Reverse the "REMOVAL" procedures.

- \* When installation, do not allow foreign particles to enter the carburetor.

Check the carburetor insulator and O-rings for wear or damage.

- \* When installation, be sure the insulator O-ring face the intake manifold.

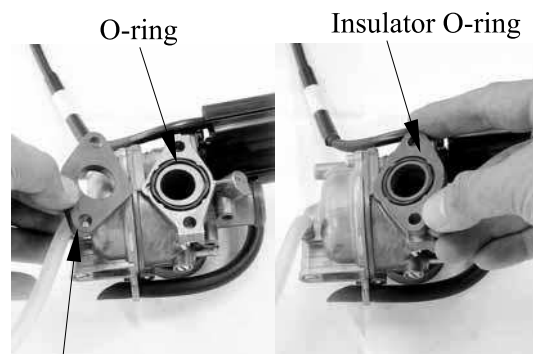

O-ring

Insulator O-ring

Insulator

## 5. FUEL SYSTEM

### DISASSEMBLY

Remove auto bystarter cap.

Remove the two screws and then remove auto bystarter and plate.

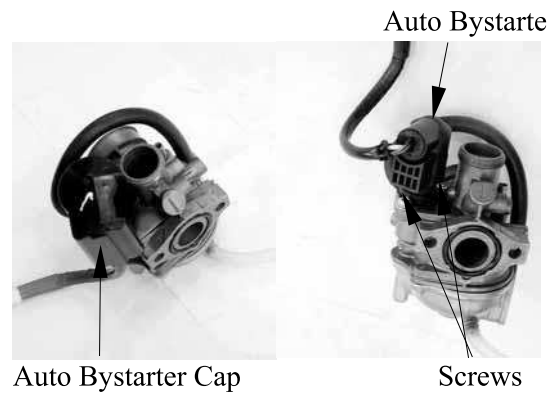

Remove the three float chamber screws and remove the float chamber.

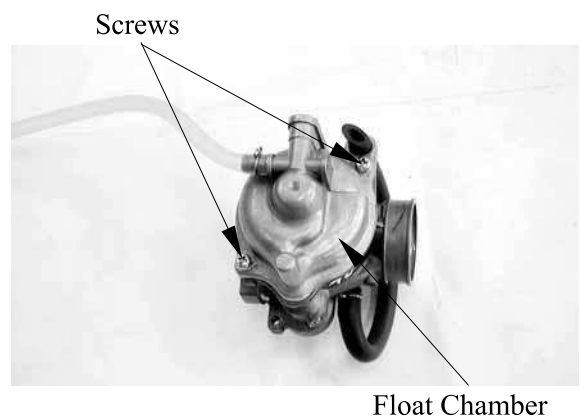

Pull out the float pin, then remove float and float valve.

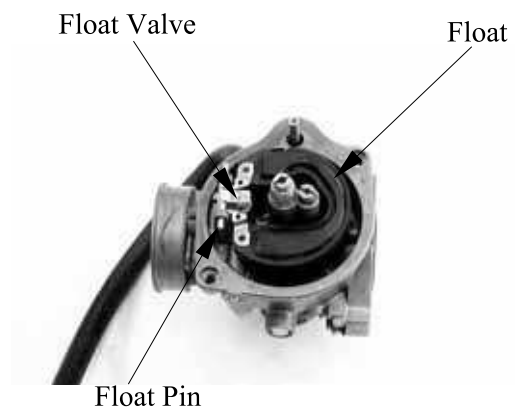

Remove the main jet, needle jet holder, and needle jet.  
Remove the slow jet.  
Remove the air screw and throttle stop screw.

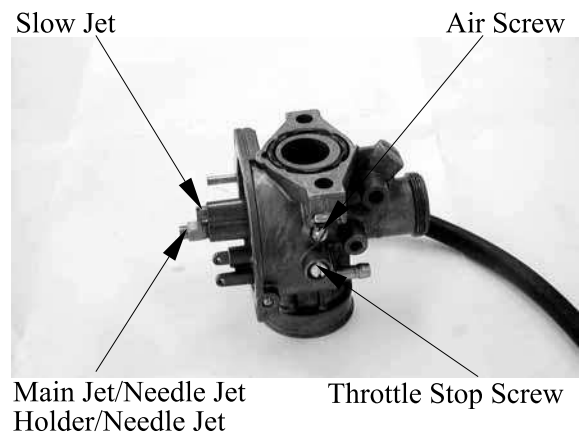

## 5. FUEL SYSTEM

### CAUTIONS!

- \* Be careful not to damage the jets and jet holder when removing them.
- Before removal, turn the throttle stop screw and air screw in and count the number of turns until they seat lightly and then make a note of this.
- Do not force the screw against its seat to avoid seat damage.
- Be sure to install the O-ring in the reverse order of removal.

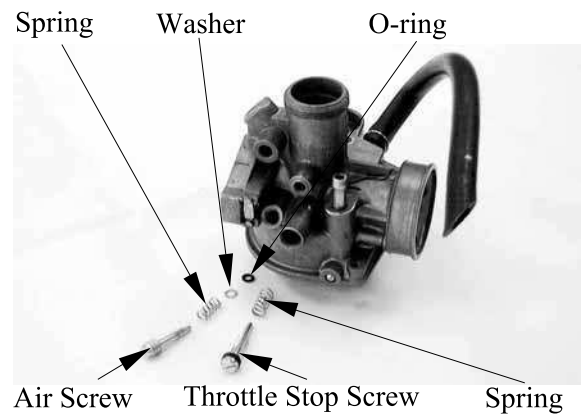

### ASSEMBLY

Reverse the “DISASSEMBLY” procedures.

- \* When installing the air screw, return it to the original position as noted during removal
- Refer to the “CARBURETOR IDLE SPEED” section in chapters to perform the idle speed adjustment.
- After the carburetor is installed, be sure to perform the Exhaust Emission

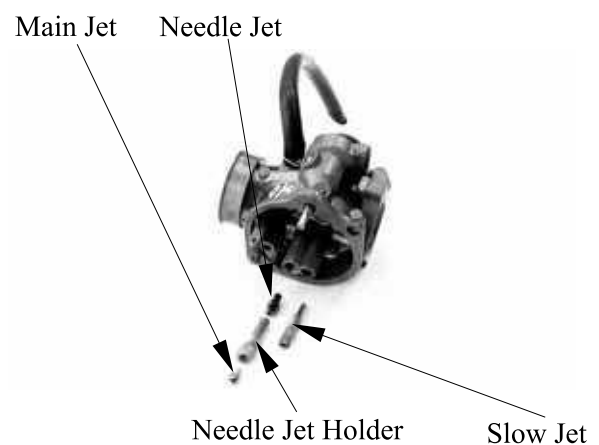

## 5. FUEL SYSTEM

### CARBURETOR CLEANING

Blow compressed air through all passages of the carburetor body.



### FLOAT/FLOAT VALVE INSPECTION

Inspect the float valve seat for wear or damage.  
Inspect the float for damage or fuel level inside the float chamber.



### FUEL RESERVOIR O-RING CHECK

Remove the O-ring.

Inspect the check the O-ring for damage.  
Replace with new ones if necessary



### FLOAT LEVEL INSPECTION

Turn the carburetor upside down so that the float will go down to make the float valve contact the float valve seat.  
Then slowly tilt the carburetor and measure the float level with the float level gauge while the float pin just contacts with float valve.

**Float Level:** 8.0mm

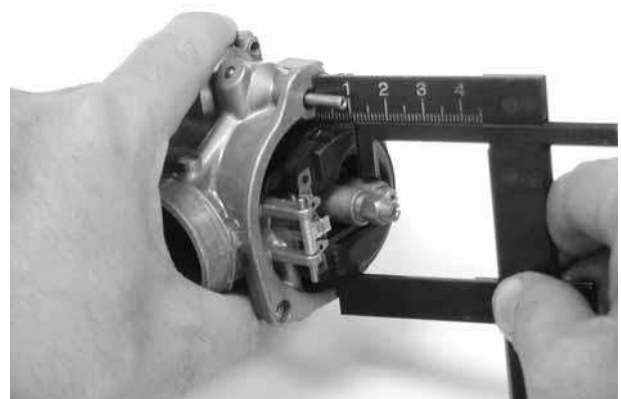

## 5. FUEL SYSTEM

### AUTO BYSTARTER INSPECTION

Measure the resistance between the auto bystarter wire terminals.

**Resistance:**  $5\Omega$  (10 minutes minimum after stopping the engine)

If the resistance exceeds  $5\Omega$ , replace the auto bystarter with a new one.



After the engine stops for 30 minutes, connect a hose to the fuel enriching circuit and blow the hose with mouth.

If air cannot be blown into the hose (clogged), the auto bystarter is faulty. Replace it with a new one.

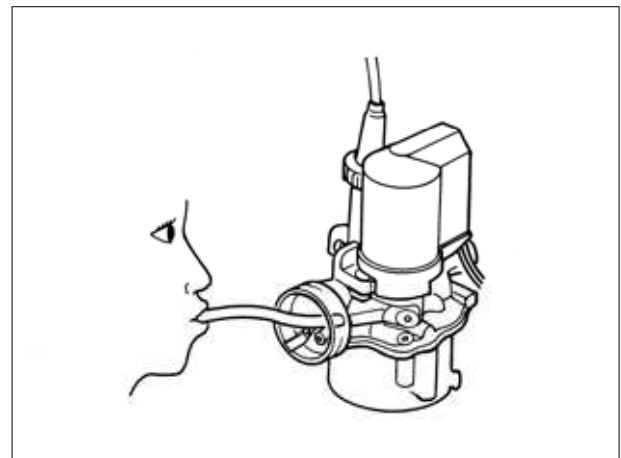

Connect the auto bystarter yellow wire to the battery positive (+) terminal and green/ black wire to the battery negative (-) terminal and wait 5 minutes.

Connect a hose to the fuel enriching circuit and blow the hose with mouth.

If air can be blown into the hose, the auto bystarter is faulty and replace it with a new one.

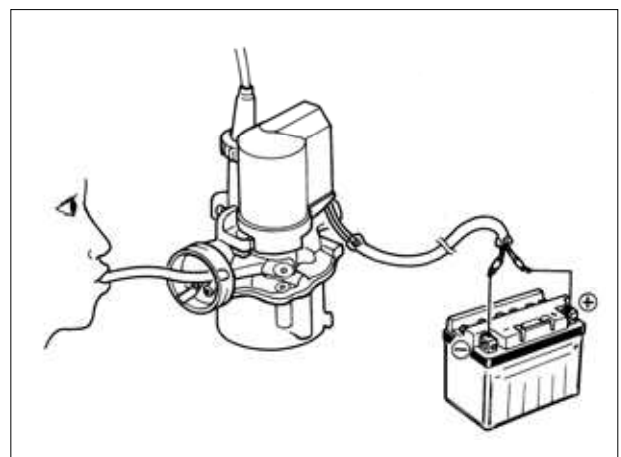

## 5. FUEL SYSTEM

### REED VALVE (Mongoose/KXR 50)

#### REMOVAL

Remove the oil pump control cable plate.  
(See page 4-11)  
Remove carburetor. (See page 5-11)  
Remove the three intake manifold bolts and gasket.  
Remove the reed valve and gasket.

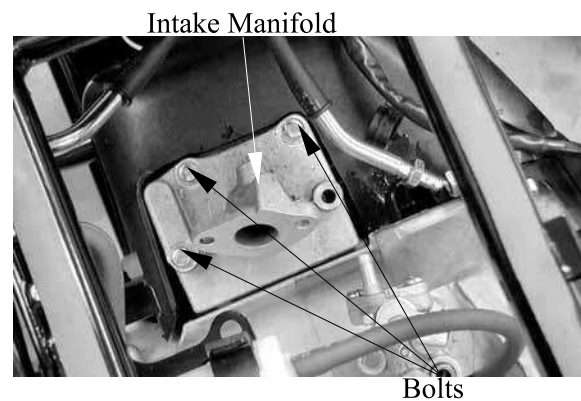

#### INSPECTION

Check the reed valve for damaged or weak reeds.  
Check the reed valve seat for cracks, damage or clearance between the seat and reed.  
Replace the valve if necessary.

\*

Do not disassemble or bend the reed stopper. To do so can cause loss of engine power and engine damage. If any of the stopper, reed or valve seat is faulty, replace them as unit.

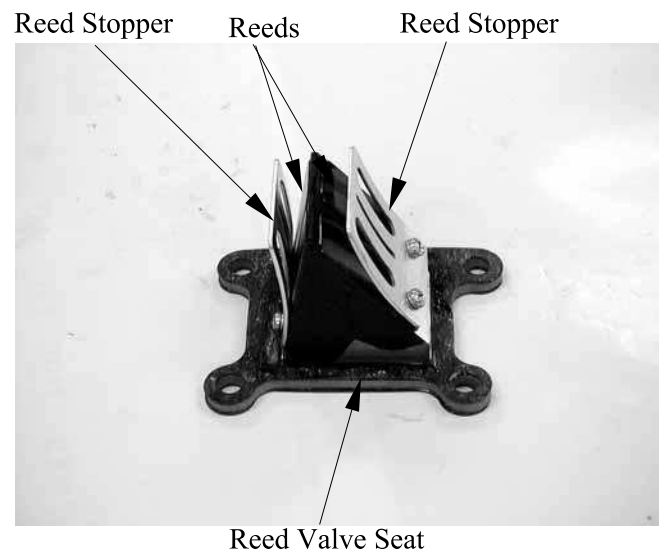

#### INSTALLATION

Install the reed valve in the reverse order of removal.

\*

Install a new gasket with the gasket indentation aligned with the reed valve.  
After installation, check for intake air leaks.

## 6. ENGINE REMOVAL

---

---

---

---

---

---

---

---

---

### ENGINE REMOVAL

**6**

---

SERVICE INFORMATION-----	6- 1
ENGINE REMOVAL (Mongoose/KXR 90)-----	6- 2
ENGINE REMOVAL (Mongoose/KXR 50)-----	6- 4

## **6. ENGINE REMOVAL/INSTALLATION**

### **SERVICE INFORMATION**

#### **GENERAL INSTRUCTIONS**

- A floor jack or other adjustable support is required to support and maneuver the engine.  
Be careful not to damage the machine body, cables and wires during engine removal.
- Use shop towels to protect the machine body during engine removal.
- Parts requiring engine removal for servicing:
  - Crankcase
  - Crankshaft



## 6. ENGINE REMOVAL

### ENGINE REMOVAL (Mongoose/KXR 90)

Drain engine oil and transmission oil.

(Refer to chapter 3)

Remove frame covers and exhaust pipe.

(Refer chapter 2)

Remove air cleaner and carburetor. (Refer to chapter 5)

Remove the two bolts on the drive sprocket.  
Remove the drive sprocket and washer.

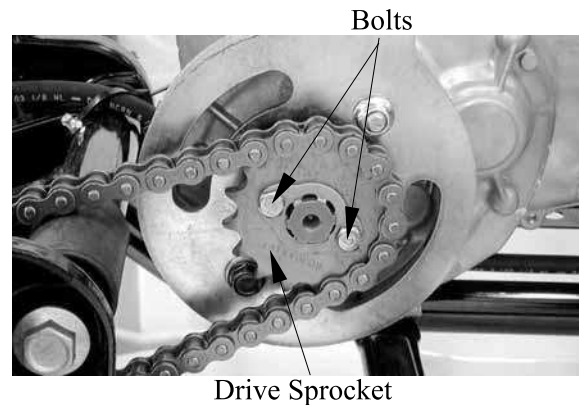

Remove the spark plug cap.

Disconnect the A.C. generator and starter motor couplers.

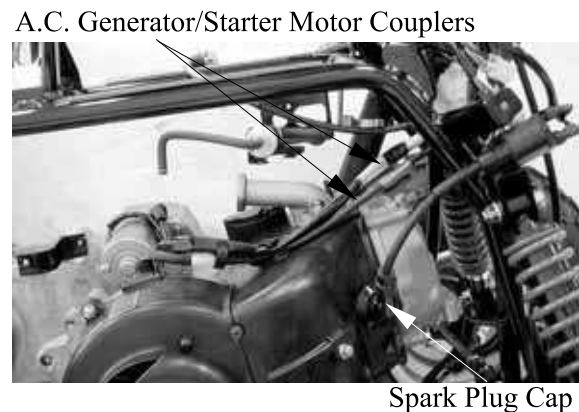

Remove the front two mounting bolts and two nuts at the engine right/left side.

Remove the four bolts and then remove the left and right engine brackets at the engine right/left side.

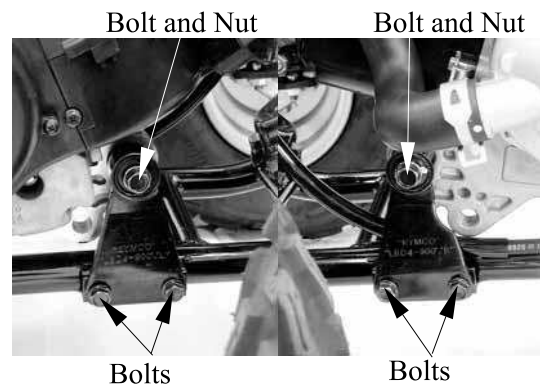

Remove the rear two mounting bolts and two nuts.

Disconnect the inlet hose from the frame.

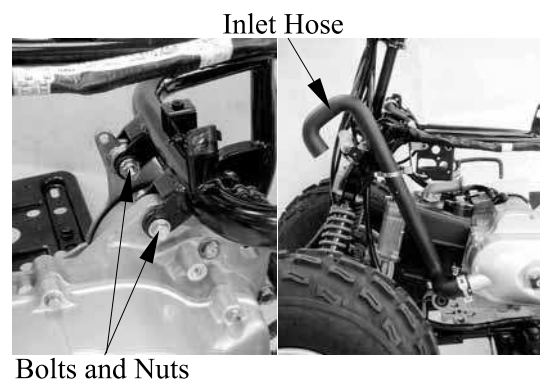

## 6. ENGINE REMOVAL/INSTALLATION

Remove the engine assembly to the left side of the machine.

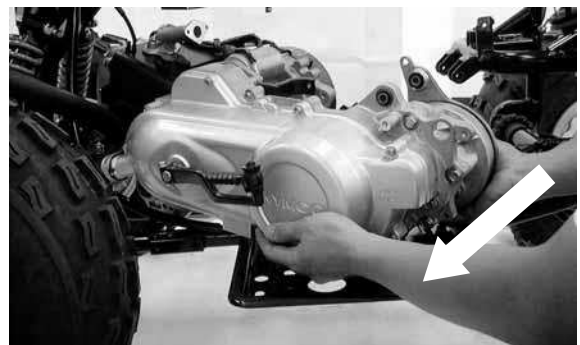
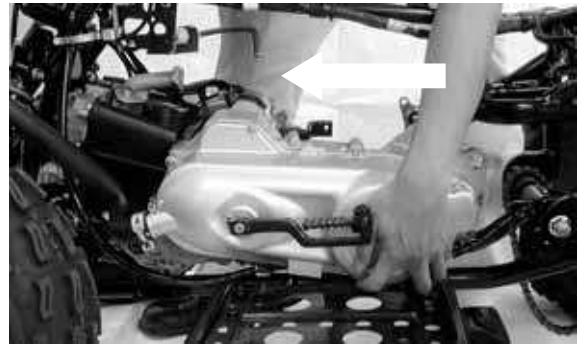

### INSTALLATION

Reverse the “REMOVAL” procedures.

### TORQUE VALUES

Front engine bracket bolt 4.0~5.0kgf-m

Rear engine bracket bolt 2.0~2.4kgf-m

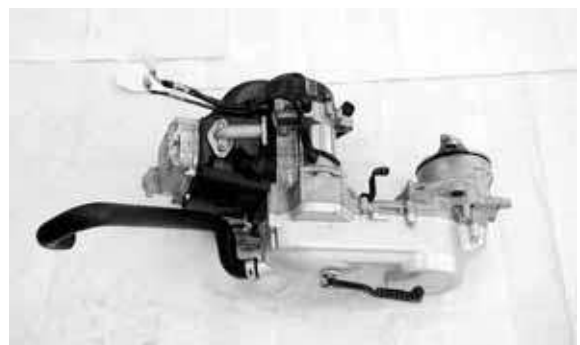

## 6. ENGINE REMOVAL

### ENGINE REMOVAL (Mongoose/KXR 50)

Remove frame covers and exhaust pipe.  
(Refer to chapter 2)

Remove oil tank. (Refer to chapter 4)

Remove air cleaner and carburetor. (Refer to chapter 5)

Drain transmission oil. (Refer to chapter 3)

Disconnect the A.C. generator and starter motor couplers.

Remove the spark plug cap.

Remove the two bolts on the drive sprocket.

Remove the drive sprocket and washer.

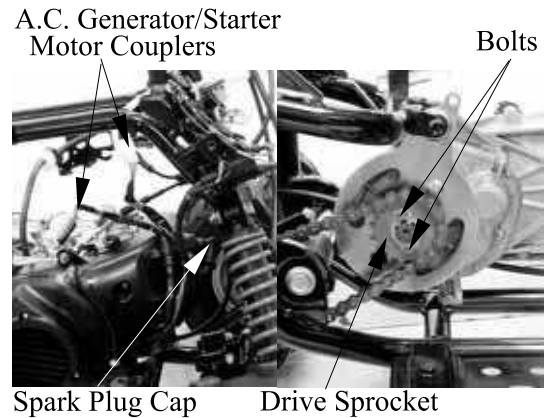

Remove the front two mounting bolts and two nuts at the engine right/left side.

Remove the four bolts and then remove the left and right engine brackets at the engine right/left side.

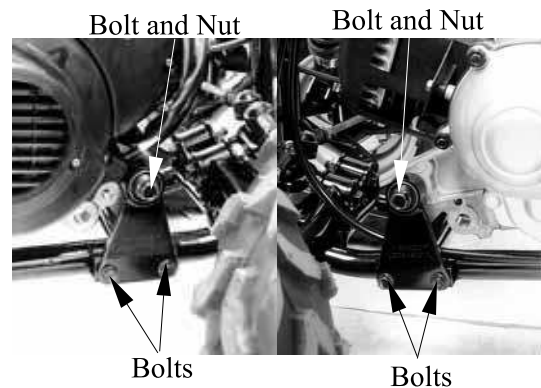

Remove the rear two mounting bolts and two nuts.

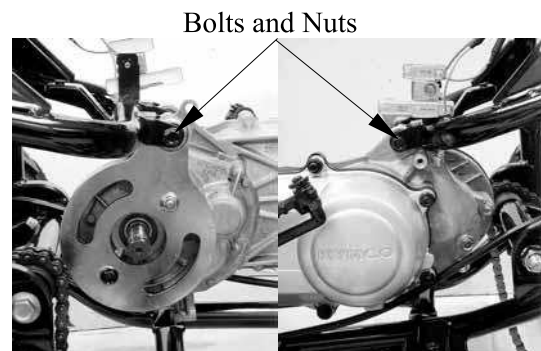

## 6. ENGINE REMOVAL/INSTALLATION

Mongoose/KXR 90/50

Remove the engine assembly to the left side of the machine.

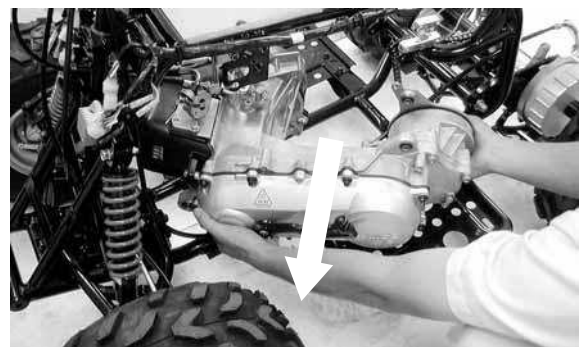
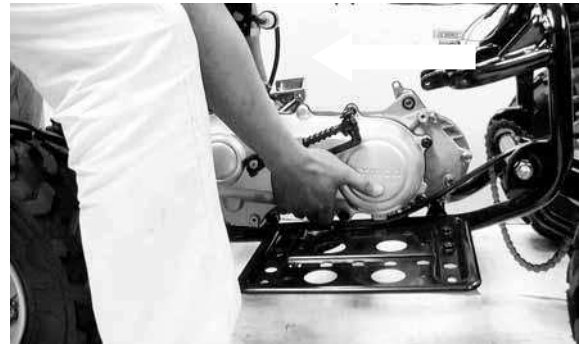

### INSTALLATION

Reverse the "REMOVAL" procedures.

### TORQUE VALUES

Front engine bracket bolt 4.0~5.0kgf-m

Rear engine bracket bolt 2.0~2.4kgf-m



# 7. CYLINDER HEAD/VALVES (Mongoose/KXR 90)

---

---

---

---

---

---

---

## CYLINDER HEAD/VALVES (Mongoose/KXR 90)

**7**

---

SERVICE INFORMATION-----	7- 2
CYLINDER HEAD COVER-----	7- 4
CAMSHAFT/CAMSHAFT HOLDER-----	7- 4
CYLINDER HEAD-----	7- 9

# 7. CYLINDER HEAD/VALVES (Mongoose/KXR 90)

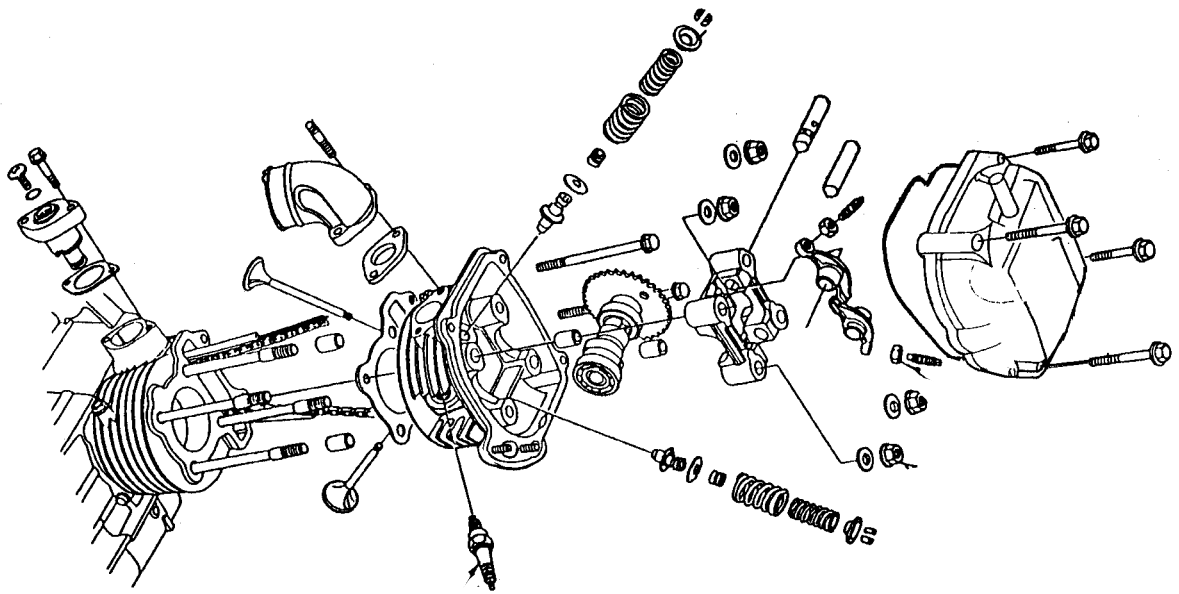

## 7. CYLINDER HEAD/VALVES (Mongoose/KXR 90)

### SERVICE INFORMATION

#### GENERAL INSTRUCTIONS

- The cylinder head can be serviced with the engine installed in the frame.
- When assembling, apply molybdenum disulfide grease or engine oil to the valve guide movable parts, valve arm and camshaft sliding surfaces for initial lubrication.
- The camshaft is lubricated by engine oil through the cylinder head engine oil passages. Clean and unclog the oil passages before assembling the cylinder head.
- After disassembly, clean the removed parts and dry them with compressed air before inspection.
- After removal, mark and arrange the removed parts in order. When assembling, install them in the reverse order of removal.

#### SPECIFICATIONS

Item		Standard (mm)	Service Limit (mm)
Valve clearance (cold)	IN	0.1	—
	EX	0.1	—
Cylinder head compression pressure		16±2kg/cm <sup>2</sup>	
Cylinder head warpage		—	0.05
Camshaft cam height	IN	26.4881	26.33
	EX	25.8073	25.65
Valve rocker arm to shaft clearance		0.034~0.09	0.1
Valve stem-to-guide clearance	IN	0.010~0.037	0.06
	EX	0.025~0.052	0.08
Valve spring free length	IN	32.3	30.8
	EX	35	33.5
Valve spring compressed force	IN	3.47~3.87kg(at 26.0mm)	—
	EX	8.29~10.19kg(at 29.0mm)	—

## 7. CYLINDER HEAD/VALVES (Mongoose/KXR 90)

### TORQUE VALUES

Cylinder head cover bolt	0.8~1.2kgf-m	Apply engine oil to threads
Cam shaft hold nut	1.8~2.2kgf-m	
Tappet adjusting nut	0.7~1.1kgf-m	

### SPECIAL TOOLS

Valve spring compressor	E040
Tappet adjuster	E036

### TROUBLESHOOTING

- The poor cylinder head operation can be diagnosed by a compression test or by tracing engine top-end noises.

#### Poor performance at idle speed

- Compression too low

#### Compression too low

- Incorrect valve clearance adjustment
- Burned or bend valves
- Incorrect valve timing
- Broken valve spring
- Poor valve and seat contact
- Leaking cylinder head gasket
- Warped or cracked cylinder head
- Poorly installed spark plug

#### Compression too high

- Excessive carbon build-up in combustion chamber

#### White smoke from exhaust muffler

- Worn valve stem or valve guide
- Damaged valve stem seal

#### Abnormal noise

- Incorrect valve clearance adjustment
- Sticking valve or broken valve spring
- Damaged or worn camshaft
- Worn cam chain guide
- Worn camshaft and rocker arm



## 7. CYLINDER HEAD/VALVES (Mongoose/KXR 90)

### CYLINDER HEAD COVER REMOVAL

Remove fuel tank. (Refer to the chapter 5)  
Disconnect the oil recycle tube at the  
cylinder head cover.

Remove the four bolts at the cylinder head  
cover, then remove the cylinder head cover.

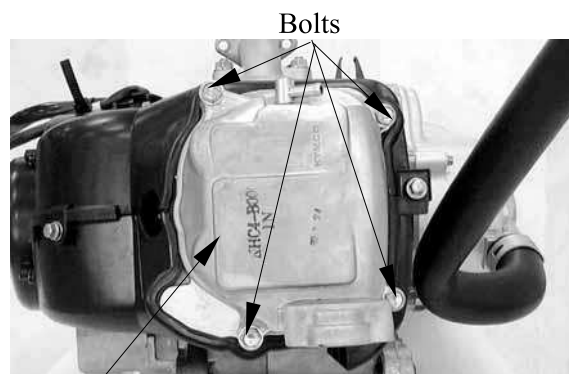

Cylinder Head Cover

### INSTALLATION

Install a new cylinder head cover O-ring  
and install the cylinder head cover.  
Install and tighten the cylinder head cover  
bolts.

**Torque:** 0.8~1.2kgf-m

\* Be sure to install the O-ring into the  
groove properly.



O-ring

### CAMSHAFT/CAMSHAFT HOLDER

#### REMOVAL

Remove the cylinder head cover. (Refer to  
the “CYLINDER HEAD COVER  
REMOVAL”)

Remove the cam chain tensioner cap, bolt  
and the O-ring.

Turn the cam chain tensioner screw  
clockwise to tighten it.

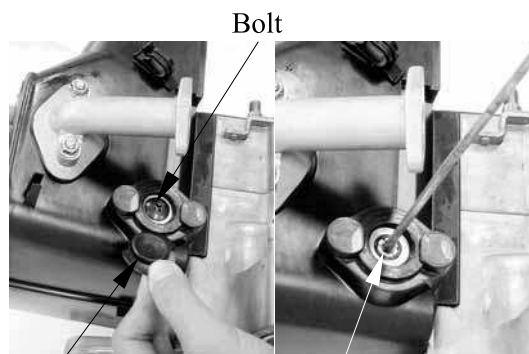

Tensioner Cap

Tensioner Screw

Turn the cooling fan clockwise so that the  
“T” mark on the flywheel aligns with the  
index mark on the crankcase to bring the  
round hole on the camshaft gear facing up  
to the top dead center on the compression  
stroke.

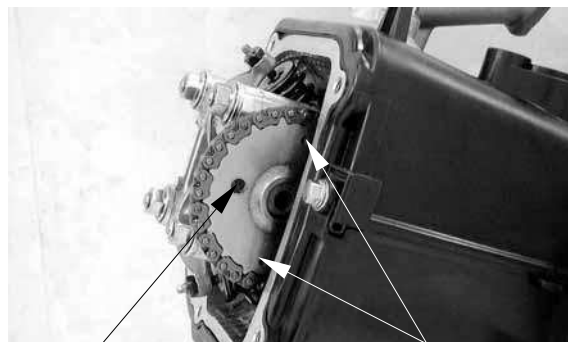

Round Hole

Punch Marks

## 7. CYLINDER HEAD/VALVES (Mongoose/KXR 90)

**KYMCO**  
Mongoose/KXR 90/50

Remove the four camshaft holder nuts and washers.

\* Diagonally loosen the cylinder head nuts in 2 or 3 times.

Nuts and Washers

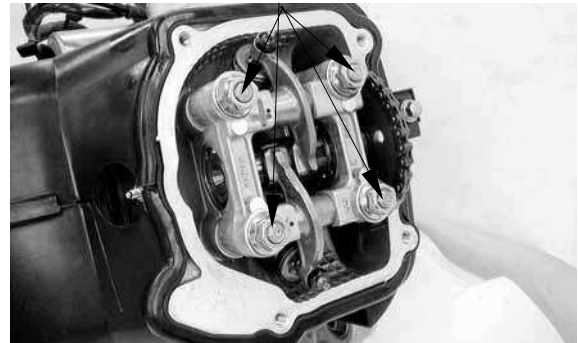

Remove the camshaft holder and dowel pins.

Camshaft Holder

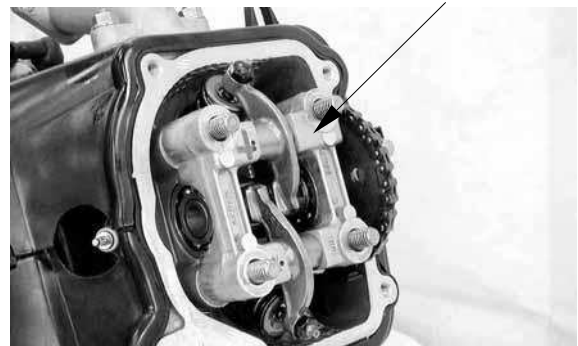

Remove the camshaft gear from the cam chain and remove the camshaft.

Camshaft

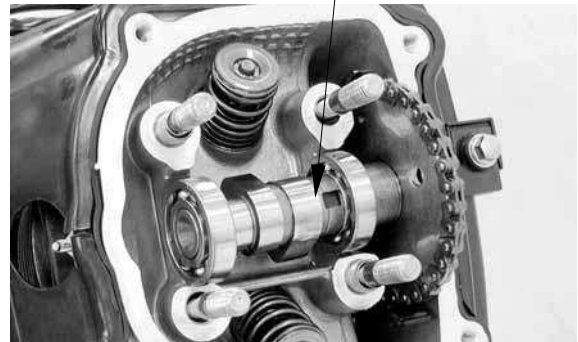

### **CAMSHAFT HOLDER DISASSEMBLY**

Take out the valve rocker arm shafts using a 5mm bolt.

Remove the valve rocker arms and arm shafts.

Rocker Arms

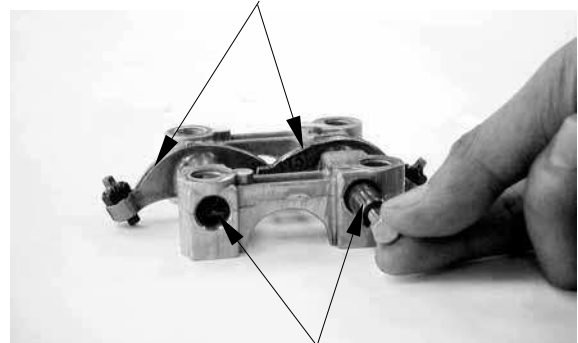

Rocker Arm Shafts

## 7. CYLINDER HEAD/VALVES (Mongoose/KXR 90)

  
Mongoose/KXR 90/50

### CAMSHAFT HOLDER INSPECTION

Inspect the camshaft holder for wear or damage.

Inspect the rocker arm shaft for blue discoloration or grooves.

If any defects are found, replace the rocker arm shaft with a new one, then inspect lubrication system.

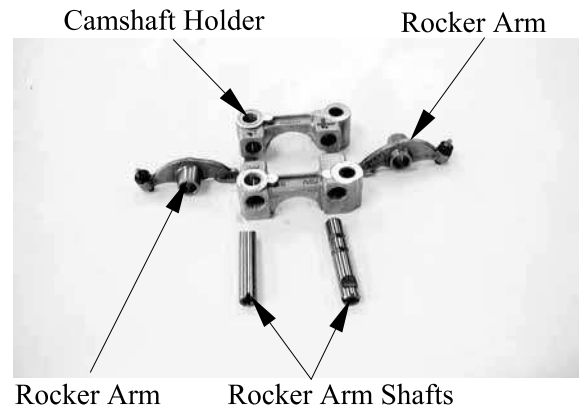

Inspect the rocker arm bore, cam lobe contact surface and adjuster surface for wear/pitting/scratches/blue discoloration.

If any defects are found, replace the rocker arm shaft with a new one, then inspect lubrication system.

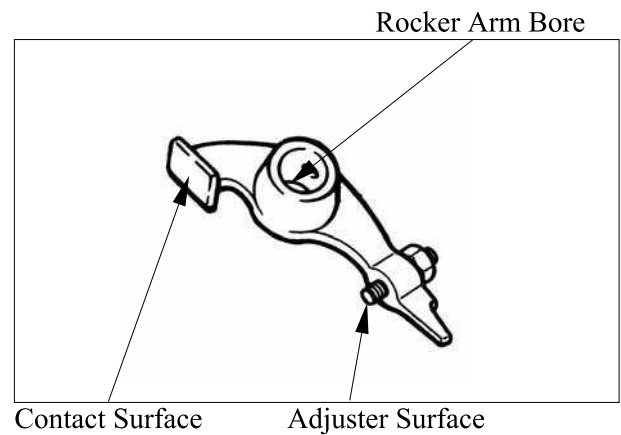

Measure each rocker arm shaft O.D.  
Measure the I.D. of each valve rocker arm.  
Measure arm to shaft clearance.  
Replace as a set if out of specification.

**Service limits:** 0.10mm

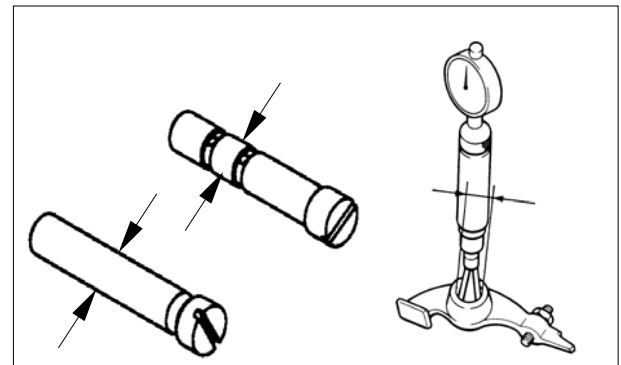

## 7. CYLINDER HEAD/VALVES (Mongoose/KXR 90)

### CAMSHAFT HOLDER ASSEMBLY

Reverse the “CAMSHAFT HOLDER DISASSEMBLY” procedures.

- \* Align the cross cutout on the exhaust valve rocker arm shaft with the bolt of the camshaft holder.

### CAMSHAFT INSPECTION

Check each camshaft bearing for play or damage. Replace the camshaft assembly with a new one if the bearings are noisy or have excessive play.

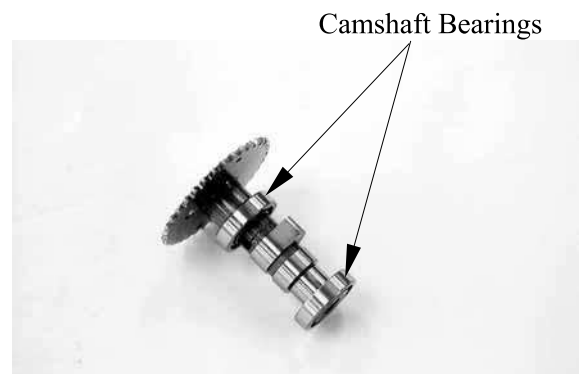

Inspect camshaft lobes for pitting/scratches/blue discoloration.

Measure the cam lobe height.

#### Service Limits:

IN : 26.33mm replace if below

EX: 25.65mm replace if below

If any defects are found, replace the camshaft with a new one, then inspect lubrication system.

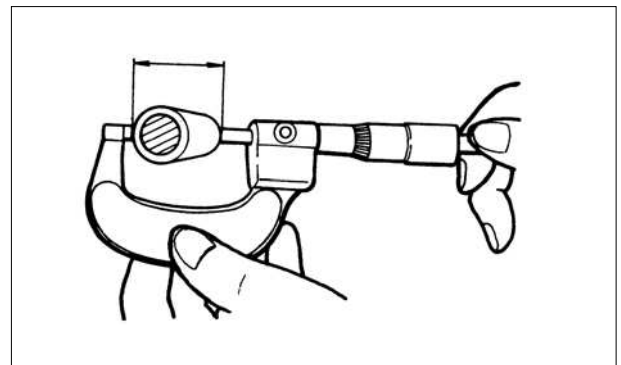

## 7. CYLINDER HEAD/VALVES (Mongoose/KXR 90)

### INSTALLATION

Reverse the “CAMSHAFT REMOVAL” procedures.

Note the following points:

1. Turn the flywheel so that the “T” mark on the flywheel aligns with the index mark on the crankcase.  
Keep the round hole on the camshaft gear facing up and align the punch marks on the camshaft gear with the cylinder head surface (Position the intake and exhaust cam lobes down.) and install the camshaft onto the cylinder head. (Refer to the “VALVE CLEARANCE” section in the chapter 3)

Install the camshaft dowel pins and holder.

- \*
  - Apply engine oil to the threads of the cylinder head nuts.
  - Diagonally tighten the cylinder head nuts in 2~3 times.
  - Position the camshaft holder “EX” mark on the exhaust valve side.

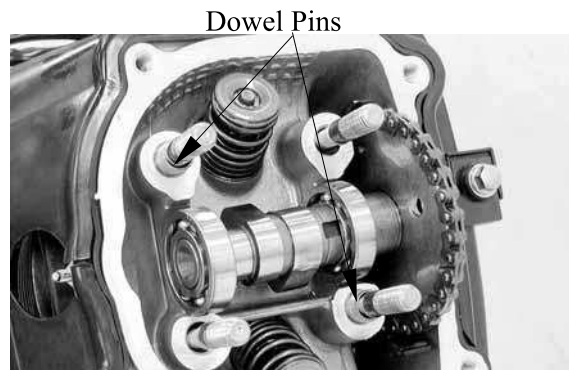

### Torque:

Cam shaft hold nut: 1.8~2.2kgf-m

Apply engine oil to threads

2. Turn the cam chain tensioner screw counter-clockwise to release it.  
Apply engine oil to a new O-ring and install it.  
Tighten the cam chain tensioner cap bolt.

- \*
  - Be sure to install the O-ring into the groove properly.

3. Adjust the valve clearance. (Refer to the “VALVE CLEARANCE” section in the chapter 3)

# 7. CYLINDER HEAD/VALVES (Mongoose/KXR 90)

## CYLINDER HEAD

### REMOVE

Remove the camshaft. (Refer to the "camshaft remove" section in the chapter 7)  
 Remove the carburetor. (Refer to the "CARBURETOR REMOVE" section in the chapter 5)  
 Remove the exhaust muffler. (Refer to the "EXHAUST MUFFLER REMOVE" section in the chapter 2)



Intake Manifold

Remove the two nuts and then remove the carburetor intake manifold.

Remove the cooling fan cover. (⇒14-8)  
 Remove the engine cover bolts and screws.  
 Separate the engine cover joint claws.

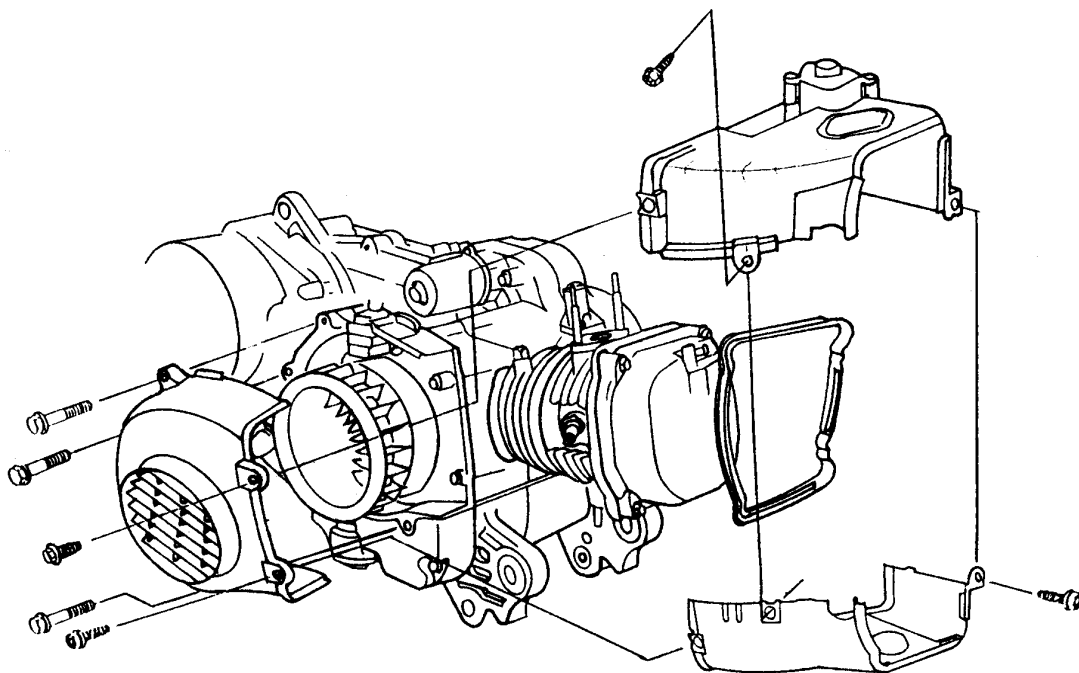

## CYLINDER HEAD DISASSEMBLY

Remove the valve spring cotters, retainers, springs, spring seats, oil seals and valves using a valve spring compressor.

\*



Valve Spring Compressor E040

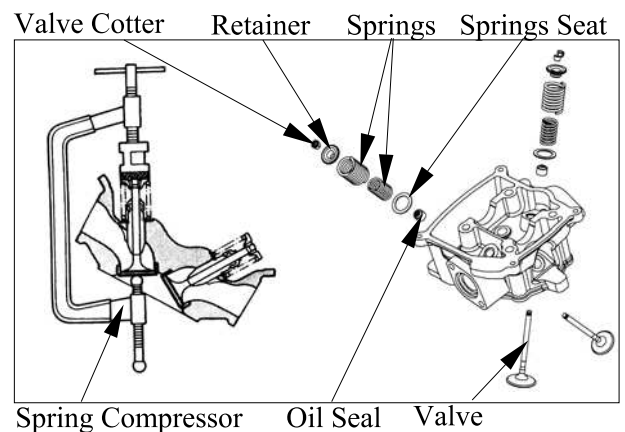

## 7. CYLINDER HEAD/VALVES (Mongoose/KXR 90)

### VALVE/VALVE GUIDE INSPECTION

Inspect each valve for bending, burning, scratches or abnormal stem wear.  
If any defects are found, replace the valve with a new one.

Check valve movement in the guide.

Measure each valve stem O.D.

Measure each valve guide I.D.

Subtract each valve stem O.D. from the corresponding guide I.D. to obtain the stem-to-guide clearance.

**Service limits:** IN : 0.06mm replace if over  
EX: 0.08mm replace if over

\* If the stem-to-guide clearance exceeds the service limits, replace the cylinder head as necessary.

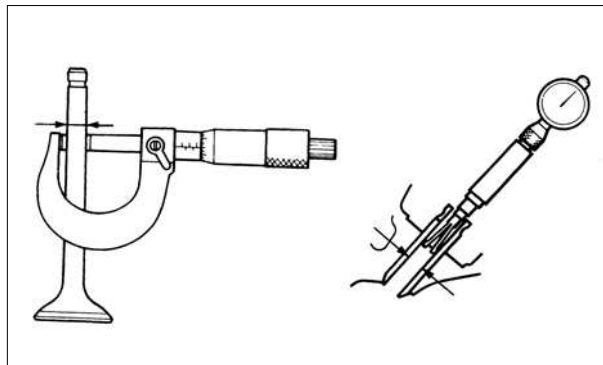

### CYLINDER HEAD INSPECTION

Check the spark plug hole and valve areas for cracks.

Check the cylinder head for warpage with a straight edge and feeler gauge.

**Service Limit:** 0.05mm repair or replace if over

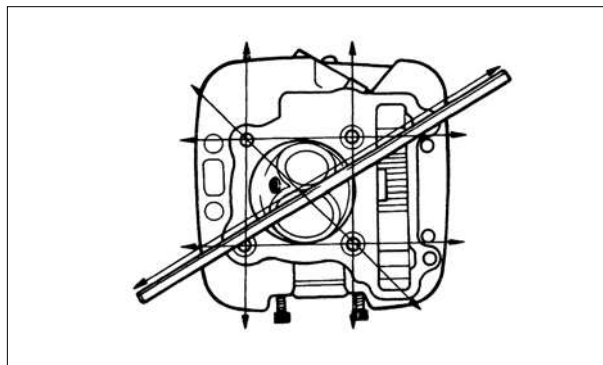

### VALVE SPRING INSPECTION

Measure the free length of the inner and outer valve springs.

**Service Limit:**

Inner: 30.8mm replace if below

Outer: 33.5mm replace if below

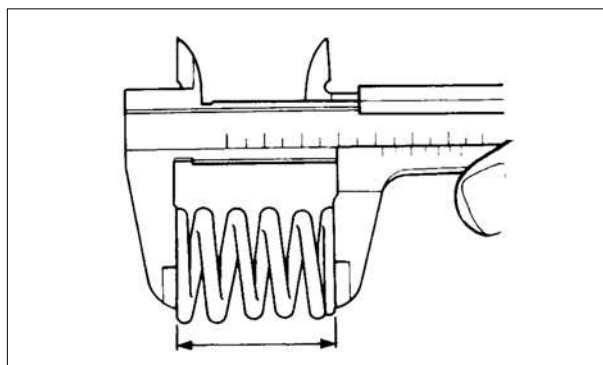

## 7. CYLINDER HEAD/VALVES (Mongoose/KXR 90)

 **KYMCO**  
Mongoose/KXR 90/50

Measure compressed force (valve spring)  
and installed length.

Replace if out of specification.

**Service limits:**

IN : 3.47~4.27kg(at 26.0mm)

EX : 8.29~10.19kg(at 29.0mm)

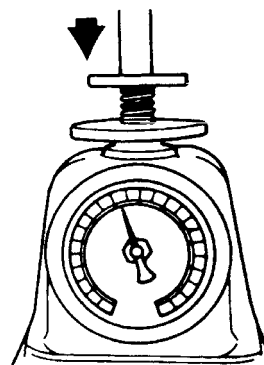

Check the intake manifold and O-rings for  
wear or damage.





## 7. CYLINDER HEAD/VALVES (Mongoose/KXR 90)

### ASSEMBLY

Install the valve spring seats and oil seal.

\*

Lubricate each valve with engine oil and insert the valves into the valve guides.

Install the valve springs and retainers.

Compress the valve springs using the valve spring compressor, then install the valve cotters.

\*

- When assembling, a valve spring compressor must be used.
- Install the cotters with the pointed ends facing down from the upper side of the cylinder head.



Valve Spring Compressor E040

Tap the valve stems gently with a plastic hammer for 2~3 times to firmly seat the cotters.

\*

Be careful not to damage the valves.

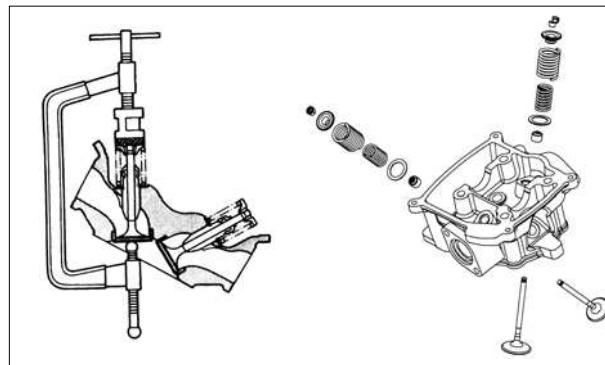

### INSTALLATION

Install the dowel pins and a new cylinder head gasket.

Reverse the “CYLINDER HEAD REMOVAL” procedures.

#### Torque:

Cylinder head bolt: 0.8~1.2kgf-m

Dowel Pins



Gasket



# 8. CYLINDER/PISTON

---

---

---

---

---

---

---

---

## CYLINDER /PISTON

---

SERVICE INFORMATION (Mongoose/KXR 90) -----	8- 3
SERVICE INFORMATION (Mongoose/KXR 50) -----	8- 4
CYLINDER/PISTON (Mongoose/KXR 90) -----	8- 5
CYLINDER HEAD (Mongoose/KXR 50) -----	8-10
CYLINDER/PISTON (Mongoose/KXR 50) -----	8-13



# 8. CYLINDER/PISTON

Mongoose/KXR 90

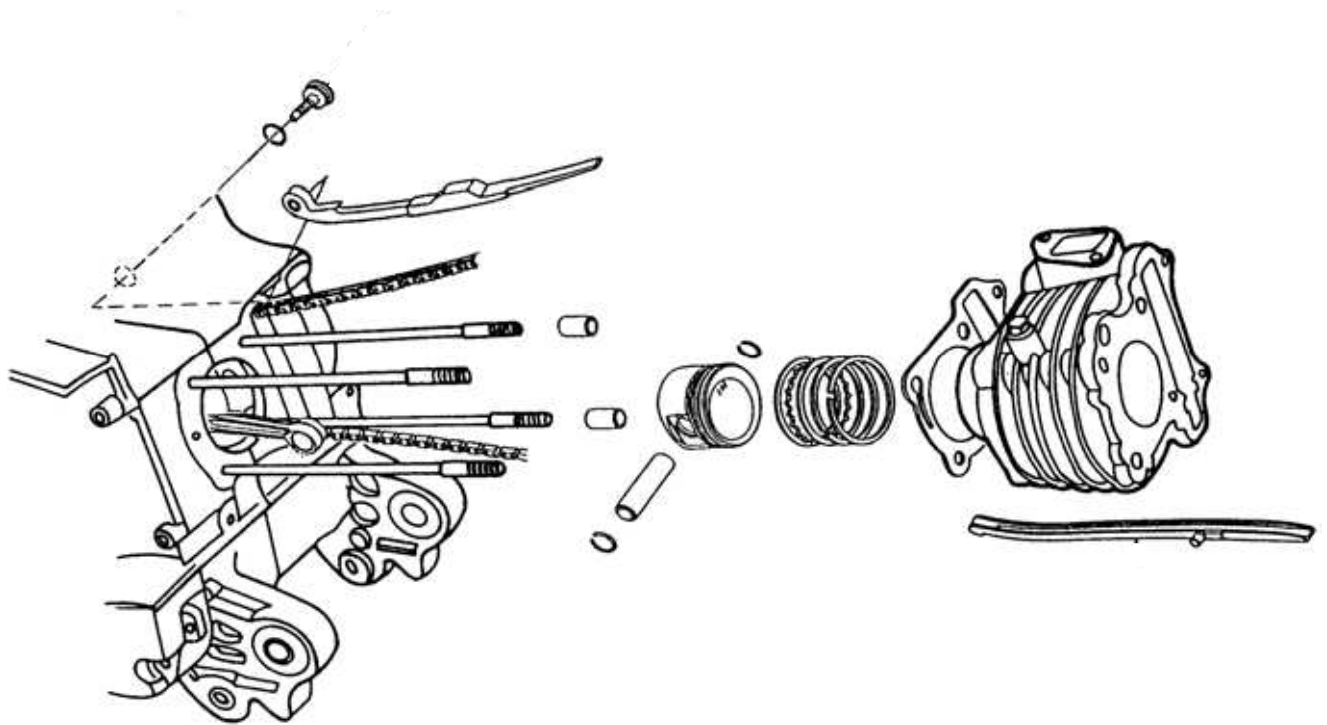

# 8. CYLINDER/PISTON

Mongoose/KXR 50

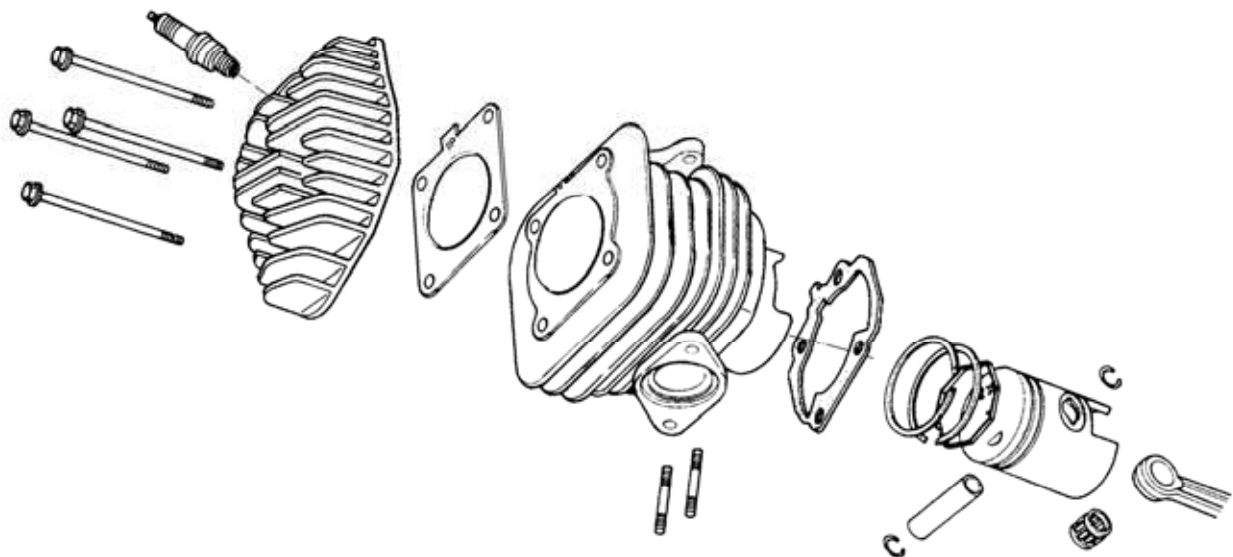

## 8. CYLINDER/PISTON

### SERVICE INFORMATION (Mongoose/KXR 90)

#### GENERAL INSTRUCTIONS

- The cylinder and piston can be serviced with the engine installed in the frame.
- Before disassembly, clean the engine to prevent dust from entering the engine.
- Remove all gasket material from the mating surfaces.
- Do not use a driver to pry between the cylinder and cylinder head, cylinder and crankcase.
- Do not damage the cylinder inside and the piston surface.
- After disassembly, clean the removed parts before inspection. When assembling, apply the specified engine oil to movable parts.

#### SPECIFICATIONS

		Standard (mm)	Service Limit (mm)	
Cylinder	I.D.	47.00~47.01	47.1	
	Warpage	—	0.05	
	Cylindricity	—	0.05	
	True roundness	—	0.05	
Piston, piston ring	Ring-to-groove clearance	Top	0.015~0.055	0.09
		Second	0.015~0.055	0.09
	Ring end gap	Top	0.15~0.3	0.5
		Second	0.3~0.45	0.65
		Oil ring	0.2~0.7	0.9
	Piston O.D.		46.97~46.99	46.9
	Piston O.D. measuring position		4mm from bottom of skirt	—
	Piston-to-cylinder clearance		0.010~0.040	0.1
Piston pin hole I.D.		13.002~13.008	13.04	
Piston pin O.D		12.994~17.000	12.96	
Piston-to-piston pin clearance		0.002~0.014	0.02	
Connecting rod small end I.D. bore		13.016~13.034	13.06	

#### TROUBLESHOOTING

- When hard starting or poor performance at low speed occurs, check the crankcase breather for white smoke. If white smoke is found, it means that the piston rings are worn, stuck or broken.

#### Compression too low or uneven compression

- Worn, stuck or broken piston rings
- Worn or damaged cylinder and piston

#### Compression too high

- Excessive carbon build-up in combustion chamber or on piston head

#### Excessive smoke from exhaust muffler

- Worn or damaged piston rings
- Worn or damaged cylinder and piston

#### Abnormal noisy piston

- Worn cylinder, piston and piston rings
- Worn piston pin hole and piston pin

## 8. CYLINDER/PISTON

### SERVICE INFORMATION (Mongoose/KXR 50)

#### GENERAL INSTRUCTIONS

- The cylinder head, cylinder and piston can be serviced with the engine installed in the frame.
- Before disassembly, clean the engine to prevent dust from entering the engine.
- Remove all gasket material from the mating surfaces.
- Do not use a driver to pry between the cylinder and cylinder head, cylinder and crankcase.
- Do not damage the cylinder inside and the piston surface.
- After disassembly, clean the removed parts before inspection. When assembling, apply the specified engine oil to movable parts.

#### SPECIFICATIONS

Item	Standard (mm)	Service Limit (mm)
Cylinder head warpage	—	0.10
Piston O.D.(3mm from bottom of piston)	38.960~38.965	38.90
Cylinder-to- piston clearance	0.035~0.05	0.10
Piston pin hole I.D.	12.002~12.008	12.03
Piston pin O.D.	11.994~12.0	11.98
Piston-to-piston pin clearance	0.002~0.014	0.03
Piston ring end gap (top/second)	0.10~0.25	0.40
Connecting rod small end I.D.	17.005~17.017	17.03
Cylinder bore	39.005~39.01	39.05

#### TORQUE VALUES

Cylinder head bolt	0.8~1.2kg-m
Spark plug	1.1~1.7kg-m

#### TROUBLESHOOTING

##### Compression too low, hard starting or poor performance at low speed

- Leaking cylinder head gasket
- Loose spark plug
- Worn, stuck or broken piston and piston rings
- Worn or damaged cylinder and piston

##### Compression too high, overheating or knocking

- Excessive carbon build-up in cylinder head or on piston head

##### Abnormal noisy piston

- Worn cylinder and piston
- Worn piston pin or piston pin hole
- Worn connecting rod small end bearing

##### Abnormal noisy piston rings

- Worn, stuck or broken piston rings
- Worn or damaged cylinder

## 8. CYLINDER/PISTON

### CYLINDER/PISTON (Mongoose/KXR 90)

#### REMOVAL

Remove the cylinder head. (Refer to the chapter 7)

Remove the two dowel pins and cylinder head gasket.

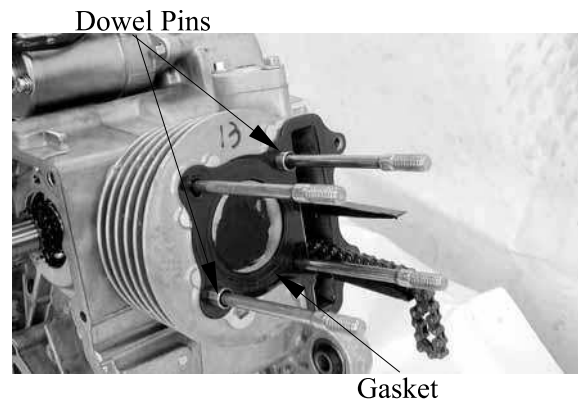

Remove cam chain guide and then remove cylinder.

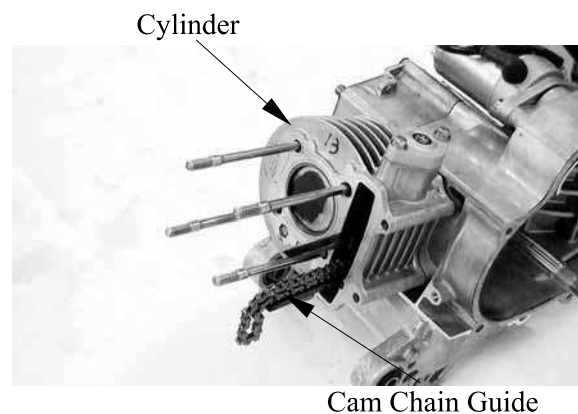

Remove the cylinder gasket and dowel pins. Clean any gasket material from the cylinder surface.

\* Be careful not to drop foreign matters into the crankcase.

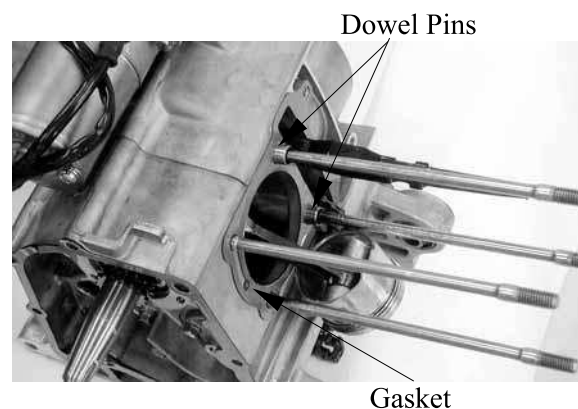

Remove the piston pin clip.

\* Place a clean shop towel in the crankcase to keep the piston pin clip from falling into the crankcase.

Press the piston pin out of the piston and remove the piston.

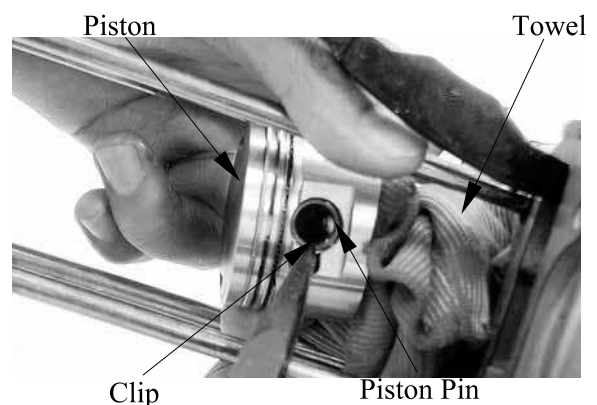

## 8. CYLINDER/PISTON

### INSPECTION

Inspect the piston, piston pin and piston rings.

Remove the piston rings.

\*

Clean carbon deposits from the piston ring grooves.

Inspect the piston wall for wear/scratches/damage.

If any defects are found, replace the piston with a new one.

Install the piston rings onto the piston and measure the piston ring-to-groove clearance.

**Service Limits: Top:** 0.09mm replace if over  
**2nd:** 0.09mm replace if over

Remove the piston rings and insert each piston ring into the cylinder bottom.

\* Use the piston head to push each piston ring into the cylinder.

Measure the piston ring end gap.

**Service Limit: Top:** 0.5mm replace if over  
**2nd:** 0.65mm replace if over  
**Oil ring:** 0.9mm replace if over

Measure the piston pin hole I.D.

**Service Limit:** 13.04mm replace if over

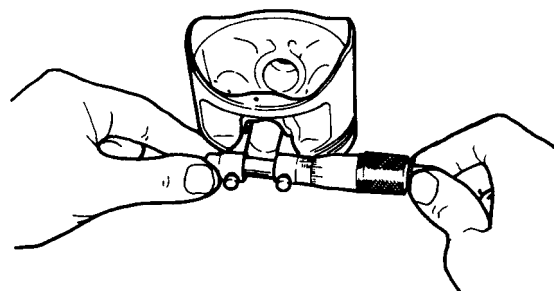
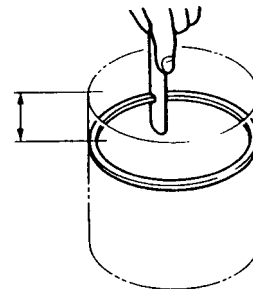
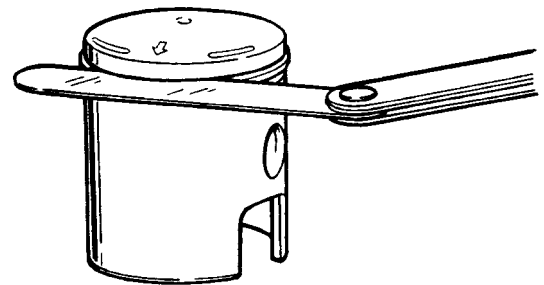



## 8. CYLINDER/PISTON

Measure the piston pin O.D.

**Service Limit:** 12.96mm replace if below

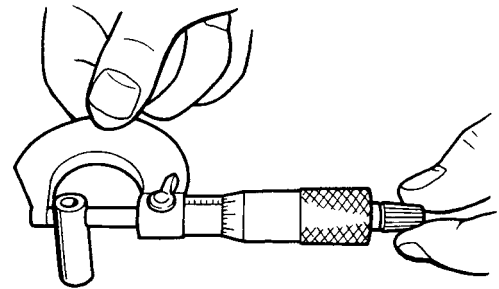

Measure the piston O.D.

\*

**Service Limit:** 46.9mm replace if below

Measure the piston-to-piston pin clearance.

**Service Limit:** 0.02mm replace if over

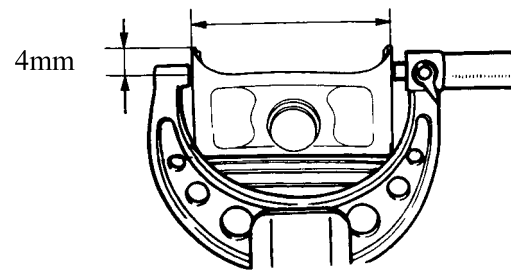

### CYLINDER INSPECTION

Inspect the cylinder bore for wear or damage. Measure the cylinder I.D. at three levels of top, middle and bottom at 90° to the piston pin (in both X and Y directions).

Cylinder I.D.:

**Service Limit:** 47.1mm replace if over

Measure the cylinder-to-piston clearance.

**Service Limit:** 0.1mm repair or replace if over

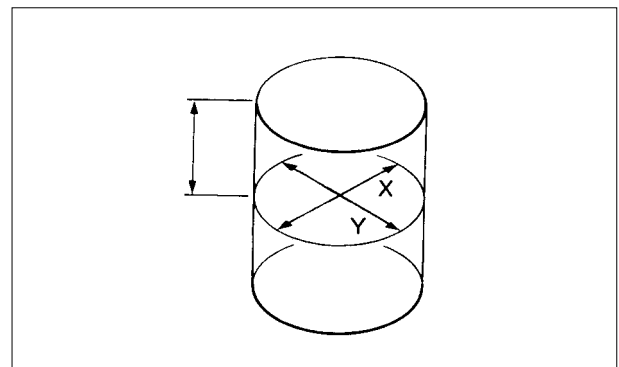

The true roundness is the difference between the values measured in X and Y directions. The cylindricity (difference between the values measured at the three levels) is subject to the maximum value calculated.

**Service Limits:**

**True Roundness:** 0.05mm repair or replace if over

**Cylindricity:** 0.05mm repair or replace if over

## 8. CYLINDER/PISTON

### PISTON RING INSTALLATION

Install the piston rings onto the piston.  
Apply engine oil to each piston ring.

- \*
- Be careful not to damage or break the piston and piston rings.
  - All rings should be installed with the markings facing up.
  - After installing the rings, they should rotate freely without sticking.

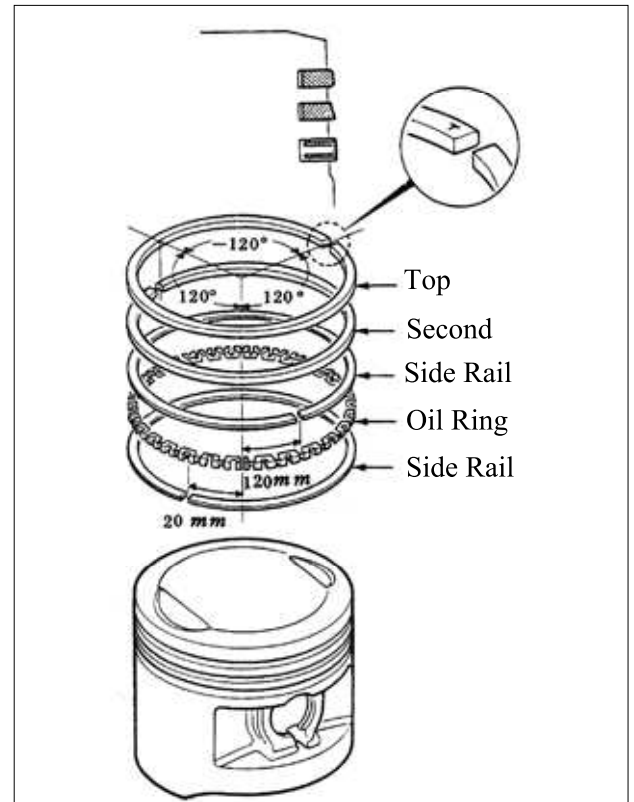

Measure the connecting rod small end I.D.

**Service Limit:** 13.06mm replace if over

Measure the connecting rod to piston pin clearance.

**Service Limit:** 0.06mm replace if over

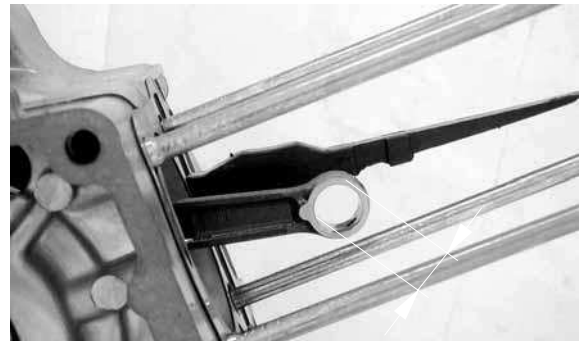

Inspect the exhaust side and intake side chain guides.

Wear/Damage → Replace.

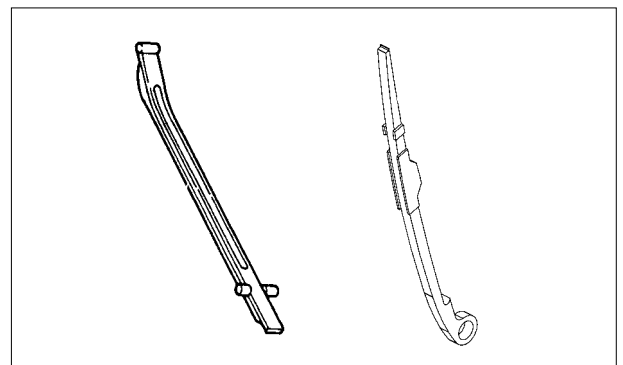

## 8. CYLINDER/PISTON

### PISTON INSTALLATION

Remove any gasket material from the crankcase surface.

- \* Be careful not to drop foreign matters into the crankcase.

Install the piston, piston pin and a new piston pin clip.

- \*
  - Position the piston "IN" mark on the intake valve side.
  - Place a clean shop towel in the crankcase to keep the piston pin clip from falling into the crankcase.



### CYLINDER INSTALLATION

Install the dowel pins and a new cylinder gasket on the crankcase.

Coat the cylinder bore, piston and piston rings with clean engine oil.

Carefully lower the cylinder over the piston by compressing the piston rings.

- \*
  - Apply proper clean engine oil around cylinder wall.
  - Be careful not to damage or break the piston rings.
  - Stagger the ring end gaps at 120° to the piston pin.

## 8. CYLINDER/PISTON

### CYLINDER HEAD (Mongoose/KXR 50)

#### REMOVAL

Remove the spark plug cap.  
Remove the exhaust muffler. (⇒2-7)

Spark Plug Cap



Remove the three bolts attaching the fan cover to remove the fan cover.  
Remove the bolt attaching the engine hood to remove the engine hood.  
The installation sequence is the reverse of removal.

Fan Cover/Engine Hood

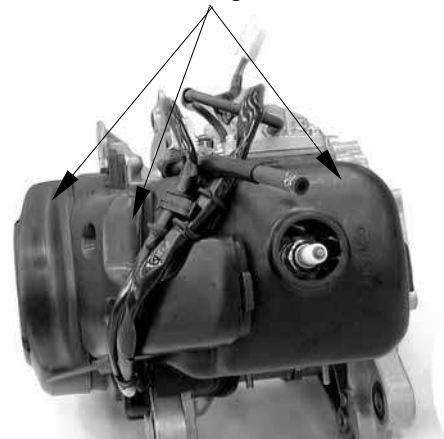

Remove the spark plug.  
Remove the cylinder head bolts and the cylinder head.

\* Loosen the bolts diagonally in 2 or 3 times.

Remove the cylinder head gasket.

Cylinder Head    Cylinder head Bolts

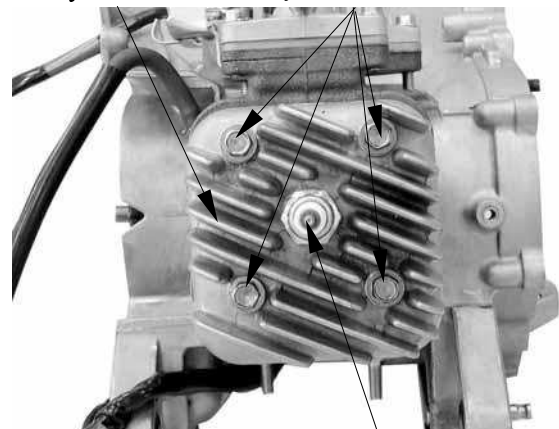

Spark Plug

## 8. CYLINDER/PISTON

### COMBUSTION CHAMBER DECARBONIZING

Remove the carbon deposits from the combustion chamber

- \* Avoid damaging the combustion chamber wall and cylinder mating surface.

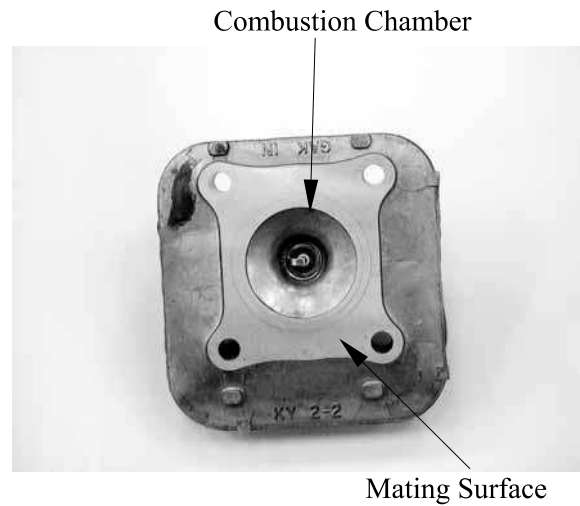

### CYLINDER HEAD INSPECTION

Check the cylinder head for warpage with a straight edge and feeler gauge.

**Service Limit:** 0.10mm replace if over

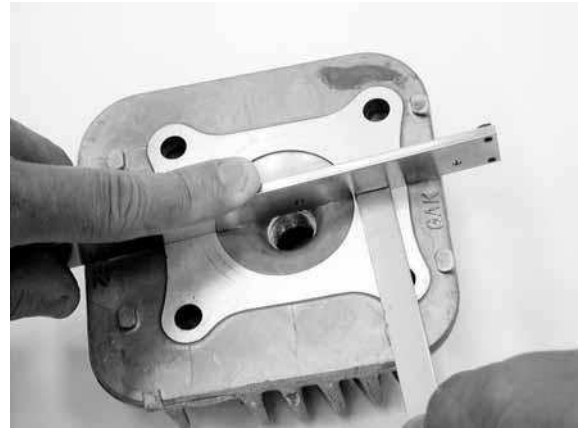

### CYLINDER HEAD INSTALLATION

Install the cylinder head on the cylinder properly.

- \* Be careful not to damage the mating surfaces.

Install a new cylinder head gasket onto the cylinder.

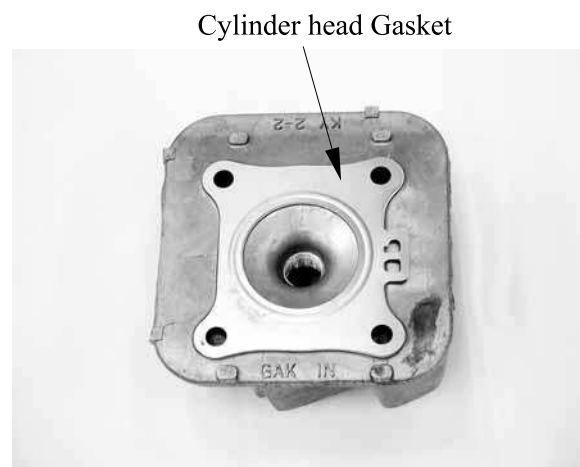

## 8. CYLINDER/PISTON

### Cylinder Head Bolts Installation

Install and tighten the cylinder head bolts diagonally in 2 or 3 times.

**Torque:** 0.8~1.2kg-m

Install the spark plug.

**Torque:** 1.1~1.7kg-m

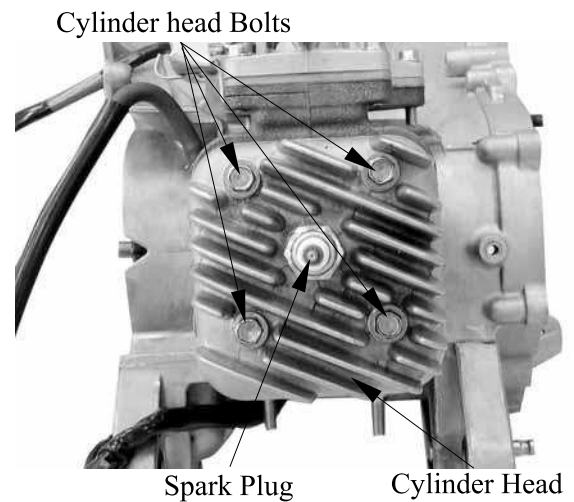

Install the engine hood and fan cover.

Perform the following inspections after installation:

- Compression test
- Abnormal engine noise
- Cylinder air leaks

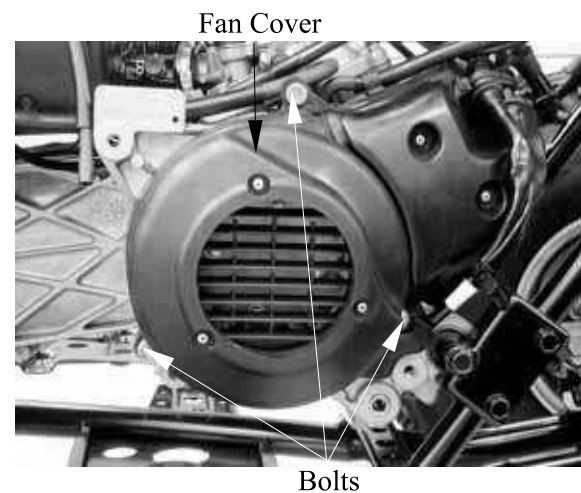
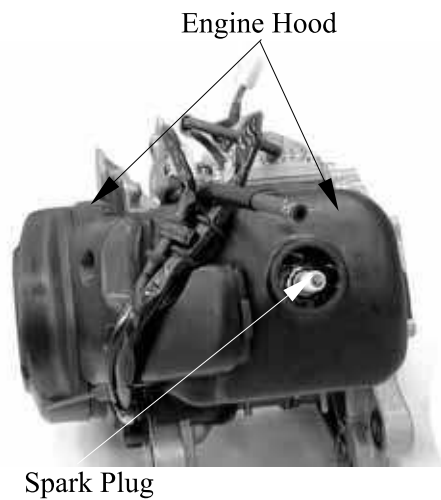

## 8. CYLINDER/PISTON

### CYLINDER/PISTON (Mongoose/KXR 50)

#### CYLINDER REMOVAL

Remove the cylinder head.

Remove the exhaust muffler. (See page 2-7)

Remove the reed valve. (See page 5-16)

Remove the cylinder.

Remove the cylinder gasket.

\*

Do not pry between the cylinder and crankcase or strike the fins.

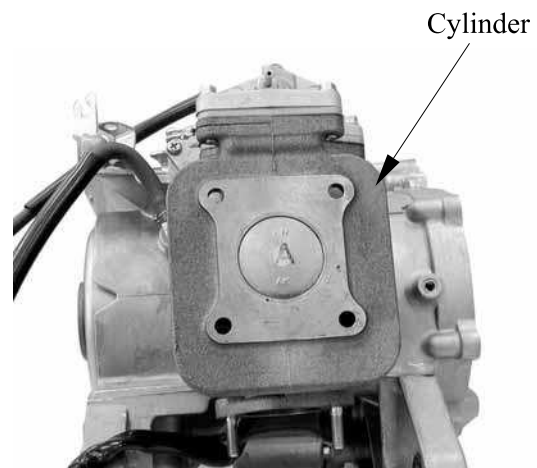

#### PISTON REMOVAL

Remove the piston pin clip to remove the piston pin and piston.

\*

- Do not damage or scratch the piston.
- Do not apply side force to the connecting rod when removing the piston pin.
- Place clean shop towels in the crankcase to keep the piston pin clip from falling into the crankcase.

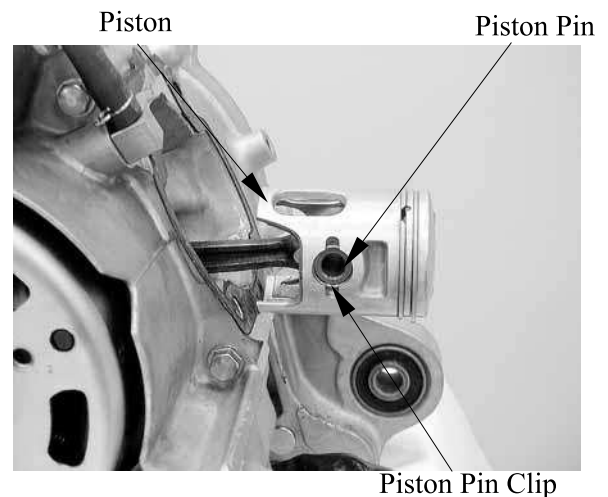

Spread each piston ring and remove by lifting it up at a point just opposite the gap.  
Remove the expander.



## 8. CYLINDER/PISTON

### CYLINDER/PISTON INSPECTION

Check the cylinder and piston for wear or damage.

Clean carbon deposits from the exhaust port area.

- \* Be careful not to damage the cylinder inside wall.



Measure the cylinder bore at three levels of A, B and C in both X and Y directions. Avoid the port area. Take the maximum figure measured to determine the cylinder bore.

**Service Limit:** 39.05mm replace if over

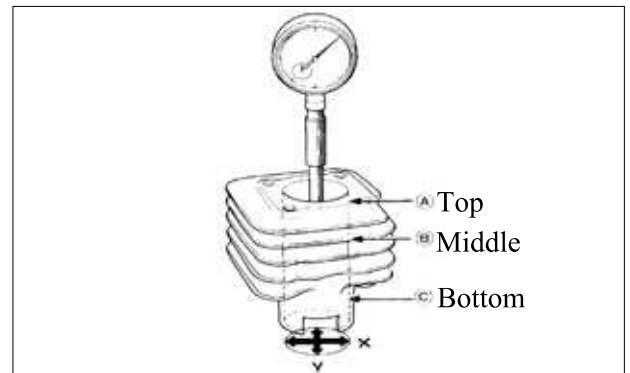

Inspect the top of the cylinder for warpage.

**Service Limit:** 0.10mm replace if over





## 8. CYLINDER/PISTON

\* The cylinder has an “A” mark or no mark on it. When replacing the cylinder with a new one, use a cylinder having the same mark as the old one.

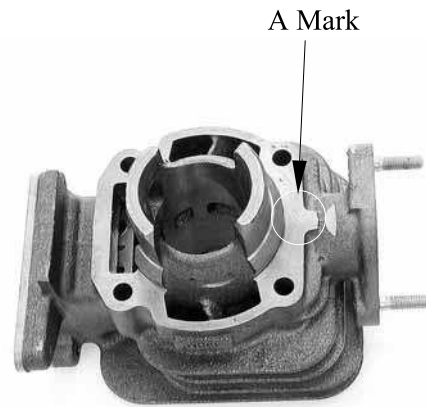

Measure the piston O.D. at a point 3mm from the bottom of the piston skirt.  
**Service Limit:** 38.90mm replace if below

Measure the piston-to-cylinder clearance.  
**Service Limit:** 0.10mm replace if over

Measure the piston pin hole I.D.  
**Service Limit:** 12.03mm replace if over



Measure the piston pin O.D.  
**Service Limit:** 11.98mm replace if below

Measure the piston-to-piston pin clearance.  
**Service Limit:** 0.03mm replace if over



## 8. CYLINDER/PISTON

### PISTON RING INSPECTION

Measure each piston ring end gap.

**Service Limits:** Top/Second  
0.40mm replace if over

\* Set each piston ring squarely into the cylinder using the piston and measure the end gap.



### CONNECTING ROD SMALL END INSPECTION

Install the piston pin and bearing in the connecting rod small end and check for excessive play.

Measure the connecting rod small end I.D.

**Service Limit:** 17.03mm replace if over



### PISTON/CYLINDER INSTALLATION

First install the expander in the second ring groove.

Then install the top and second rings in their respective ring grooves.

The piston rings should be pressed into the grooves with even force.

After installation, check and make sure that each ring is flush with the piston at several points around the ring.

A ring that will not compress means that the ring groove has carbon deposits in it and should be cleaned.

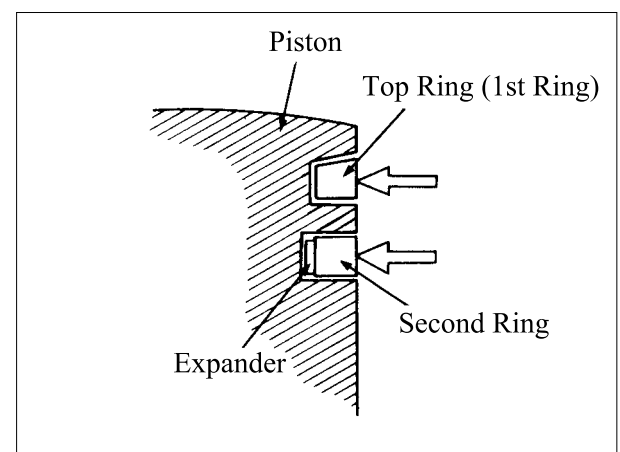

## 8. CYLINDER/PISTON

Install a new cylinder gasket on the mating surface between the cylinder and crankcase. Position the piston “IN” mark on the intake valve side.

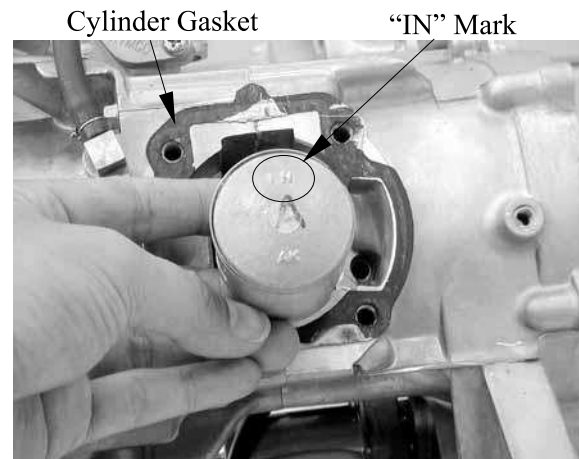

Make sure that the ring end gaps are aligned with the piston ring pins in the ring grooves. Lubricate the cylinder inside and piston rings with engine oil and install the piston into the cylinder while compressing the piston rings.

\* Be careful not to damage the piston.

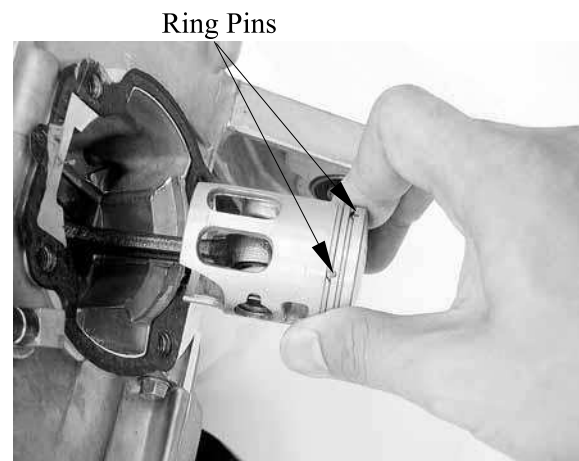

Install the cylinder head.

**Torque:** 0.8~1.2kg-m

The installation sequence is the reverse of removal .



# 9. DRIVE AND DRIVEN PULLEYS

---



## DRIVE AND DRIVEN PULLEYS

---

SERVICE INFORMATION.....	9-2
LEFT CRANKCASE COVER/KICK STARTER .....	9-4
DRIVE PULLEY .....	9-7
CLUTCH/DRIVEN PULLEY .....	9-9



**9. DRIVE AND DRIVEN PULLEYS**

Mongoose/KXR 90/50

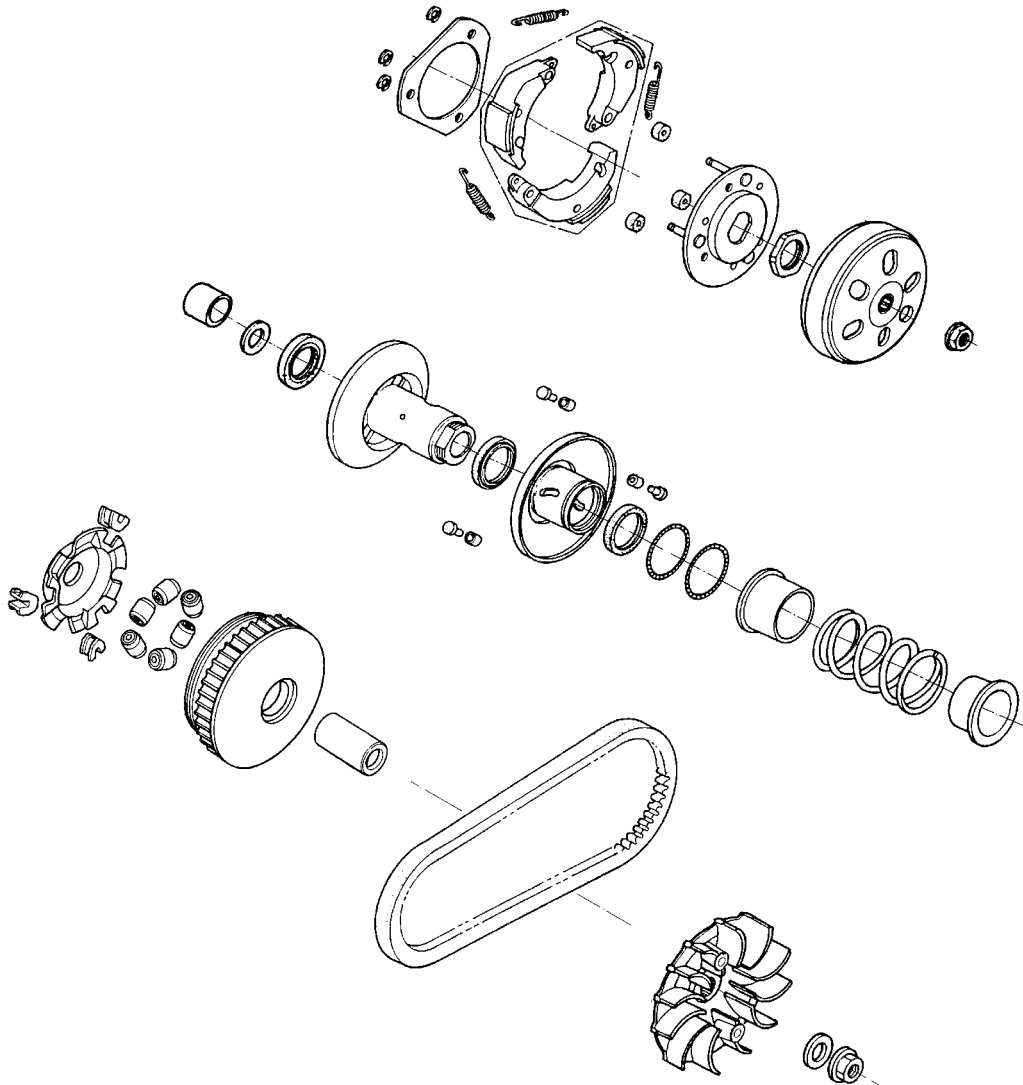

## 9. DRIVE AND DRIVEN PULLEYS

Mongoose/KXR 90/50

### SERVICE INFORMATION

#### GENERAL INSTRUCTIONS

- The drive pulley, clutch and driven pulley can be serviced with the engine installed in the frame.
- Avoid getting grease and oil on the drive belt and pulley faces. Remove any oil or grease from them to minimize the slipping of drive belt and drive pulley.

#### SPECIFICATIONS (Mongoose/KXR 90)

Item	Standard (mm)	Service Limit (mm)
Movable drive face bushing I.D.	23.989~24.052	24.06
Drive face collar O.D.	23.96~23.974	23.94
Drive belt width	17.5	16.5
Clutch lining thickness	4.5	2.0
Clutch outer I.D.	112.0~112.2	112.5
Driven face spring free length	145.5	137.5
Driven face O.D.	33.965~33.985	33.94
Movable driven face I.D.	34.000~34.025	34.06
Weight roller O.D.	15.92~16.08	15.4

#### SPECIFICATIONS (Mongoose/KXR 50)

Item	Standard (mm)	Service Limit (mm)
Movable drive face bushing	20.036~20.085	20.6
Drive face collar O.D.	20.01~20.025	19.98
Drive belt width	18	17.5
Clutch lining thickness	3.5	1.0
Clutch outer I.D.	107~107.2	107.5
Driven face spring free length	98.1	92.8
Driven face O.D.	33.965~33.985	33.94
Movable driven face I.D.	34.0~34.025	34.06
Weight roller O.D.	15.92~16.08	15.4

## 9. DRIVE AND DRIVEN PULLEYS

Mongoose/KXR 90/50

### TORQUE VALUES

Drive face nut	5.5~6.5kgf-m (Mongoose/KXR 90)
	3.5~4.5kgf-m (Mongoose/KXR 50)
Clutch outer nut	3.5~4.5kgf-m
Drive plat nut	5.0~6.0kgf-m

### SPECIAL TOOLS

Universal holder	E017	Clutch spring compressor	E034
Bearing puller	E037	Oil seal and bearing install	E014

### TROUBLESHOOTING

#### Engine starts but motorcycle won't move

- Worn drive belt
- Broken ramp plate
- Worn or damaged clutch lining
- Broken driven face spring

#### Lack of power

- Worn drive belt
- Weak driven face spring
- Worn weight roller
- Fouled drive face

#### Engine stalls or motorcycle creeps

- Broken clutch weight spring

## 9. DRIVE AND DRIVEN PULLEYS

Mongoose/KXR 90/50

### LEFT CRANKCASE COVER/KICK STARTER

#### REMOVAL

Remove left foot board. (See page 2-7)

Remove the eight left crankcase cover bolts and left crankcase cover.

Remove the gasket and dowel pins.

Use specified genuine parts for replacement.

#### KICK STARTER

##### DISASSEMBLY

Remove the kick lever from the kick starter spindle.

Remove the circlip and washer from the kick starter spindle.

Remove three bolts at the kick starter spindle cover, then remove kick starter spindle cover. Gently turn the kick starter spindle to remove the starter driven gear together with the friction spring.

Remove the kick starter spindle and return spring from the left crankcase cover. Remove the kick starter spindle bushings.

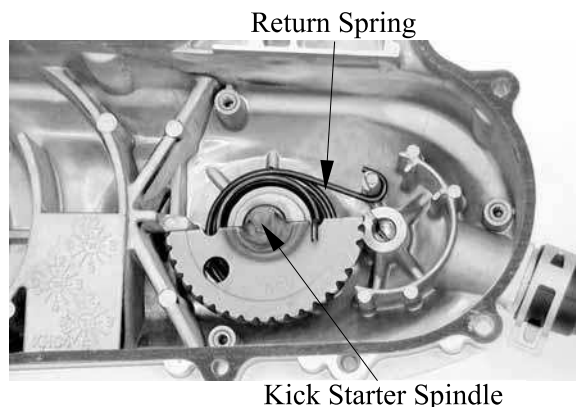
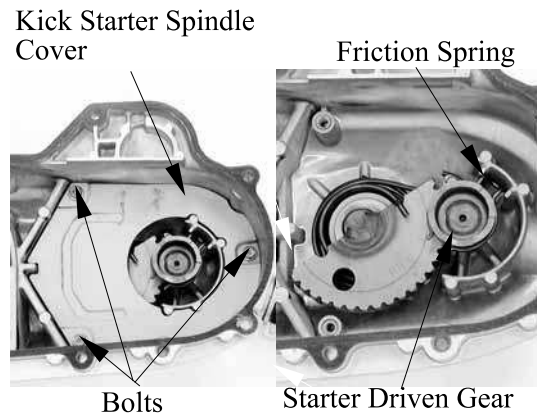
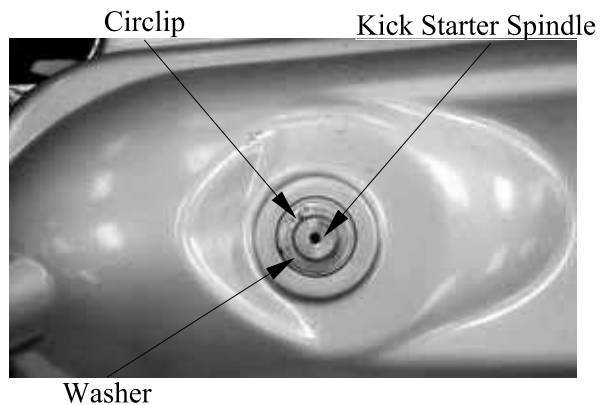
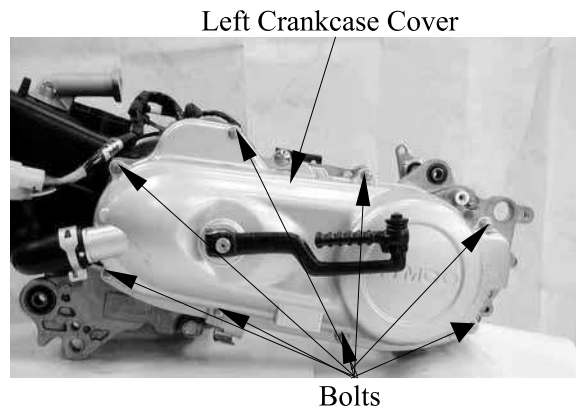



## 9. DRIVE AND DRIVEN PULLEYS

Mongoose/KXR 90/50

### INSPECTION

Inspect the kick starter spindle and gear for wear or damage.  
 Inspect the return spring for weakness or damage.  
 Inspect the kick starter spindle bushings for wear or damage.

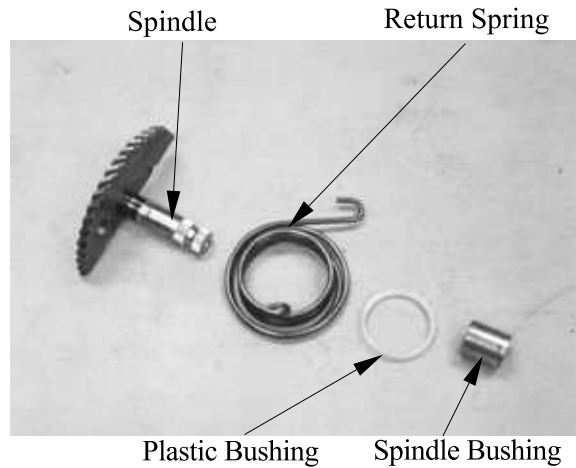

Inspect the starter driven gear for wear or damage.  
 Inspect the friction spring for wear or damage.



Inspect the kick starter spindle and starter driven gear forcing parts for wear or damage.

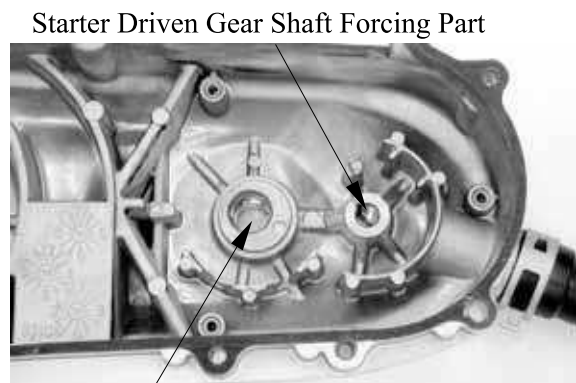

### ASSEMBLY

Install the kick starter spindle bushing and return spring onto the left crankcase cover.  
 Install the kick starter spindle.

Apply grease on to the bushing and spindle teeth.

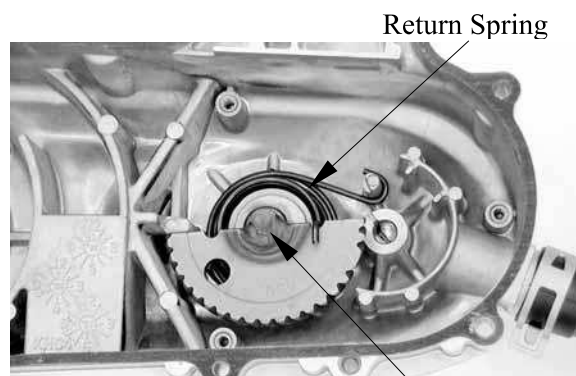

## 9. DRIVE AND DRIVEN PULLEYS

Install the starter driven gear and friction spring onto the left crankcase cover as the figure shown.

Install the kick starter spindle cover and tighten three bolts.

Apply grease on to the driven gear shaft.

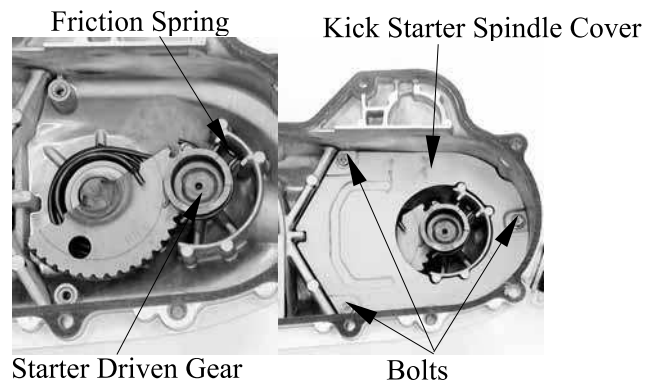

First install the washer and then install the circlip.  
Install the kick lever.

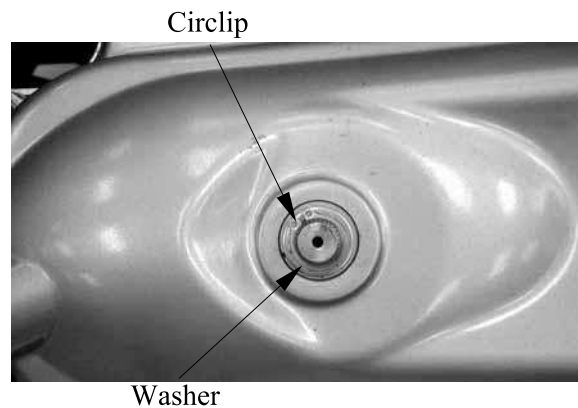

### LEFT CRANKCASE COVER INSTALLATION

First install the dowel pins.  
Install the gasket.

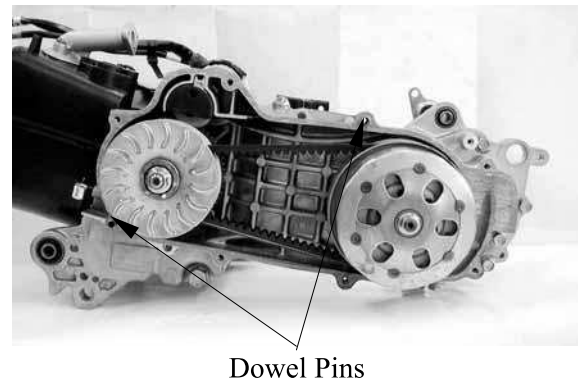

Install the left crankcase cover and tighten the eight left crankcase cover bolts diagonally.



# 9. DRIVE AND DRIVEN PULLEYS

Mongoose/KXR 90/50

## DRIVE PULLEY

### REMOVAL

Remove the left crankcase cover. (Refer to the “LEFT CRANKCASE COVER REMOVAL” section in the chapter 9)

Hold the drive pulley using a universal holder and remove the drive face nut and washer.

Remove the drive pulley.



Universal Holder E017

Remove the movable drive face assembly and drive pulley collar.

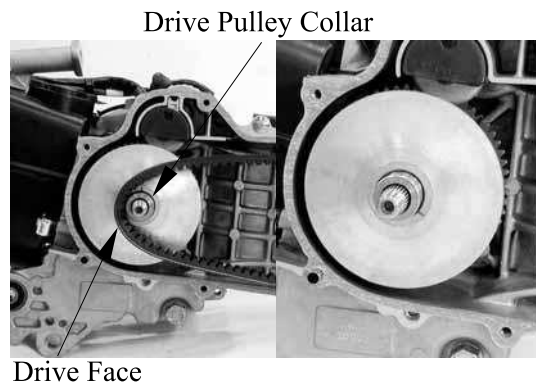
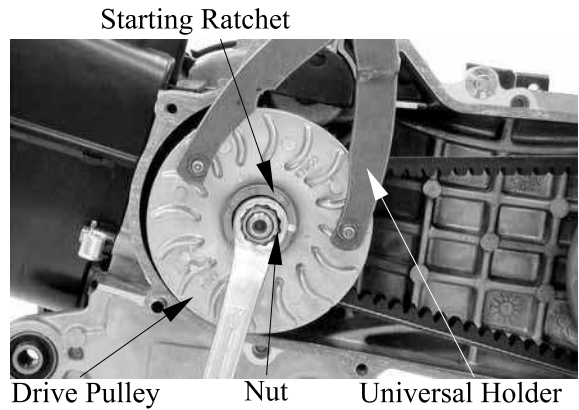

### DISASSEMBLY

Remove the ramp plate.

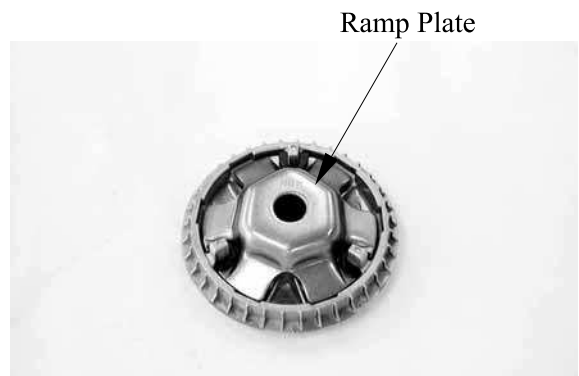

Remove the six weight rollers.

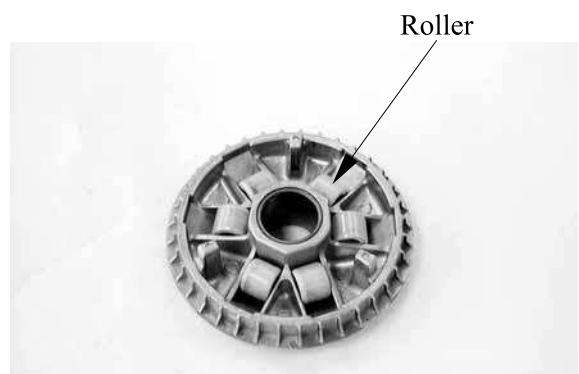

## 9. DRIVE AND DRIVEN PULLEYS

### INSPECTION

Check each weight roller for wear or damage.  
Measure each weight roller O.D.

**Service Limit:** 15.4mm replace if below.

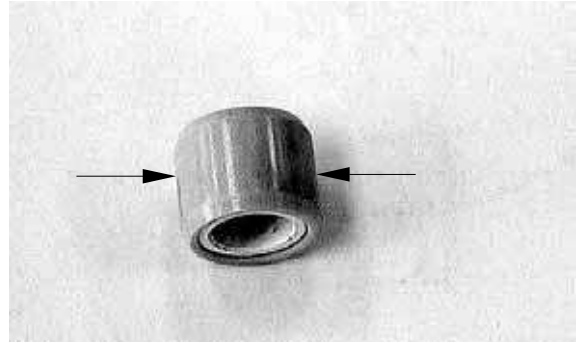

Measure the movable drive face bushing I.D.

**Service Limit:**

Mongoose/KXR 90: 24.06mm over

Mongoose/KXR 50: 20.06mm over

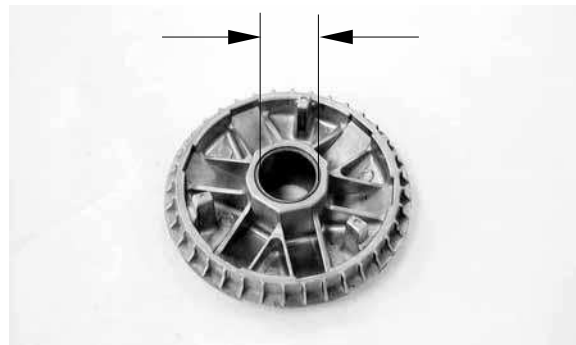

### ASSEMBLY

Install the weight rollers into the movable drive face.

Install the ramp plate.

Check the drive pulley collar for wear or damage.  
Measure the O.D. of the drive pulley collar sliding surface.

**Service Limit:**

Mongoose/KXR 90: 23.94mm below

Mongoose/KXR 50: 19.98mm below

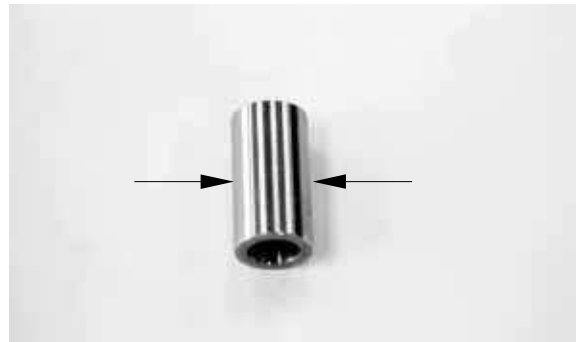

### INSTALLATION

Install the drive pulley face assembly and collar.

Install the drive pulley, starting ratchet and nut.

\*

- When installing the drive pulley face, compress it to let the drive belt move downward to the lowest position so that the drive pulley can be tightened.
- Do not get oil or grease on the drive belt or pulley faces.

**Torque:**

Mongoose/KXR 90: 5.5~6.5kgf-m

Mongoose/KXR 50: 3.5~4.5kgf-m

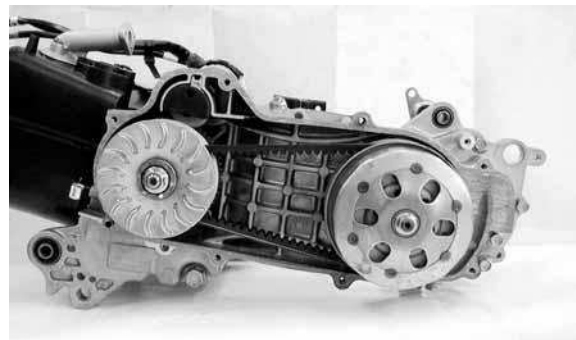

## CLUTCH/DRIVEN PULLEY

### REMOVAL

Remove the left crankcase cover. (Refer to the “LEFT CRANKCASE COVER REMOVAL” section in the chapter 9)  
 Remove the drive pulley. (Refer to the “DRIVE PULLEY REMOVAL” section in the chapter 9)

Hold the clutch outer with the universal holder, then remove the clutch outer nut and clutch outer.

**Special**

Universal Holder E017

Remove the clutch/driven pulley and drive belt.

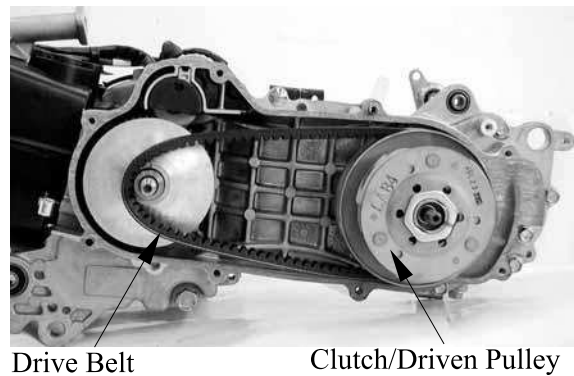
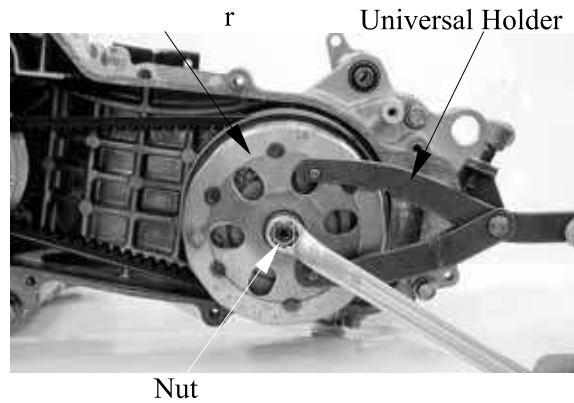

## DRIVE BELT INSPECTION

Check the drive belt for cracks, separation or abnormal or excessive wear.  
 Measure the drive belt width.

### Service Limit:

Mongoose/KXR 90: 16.5mm

Mongoose/KXR 50: 17.5mm

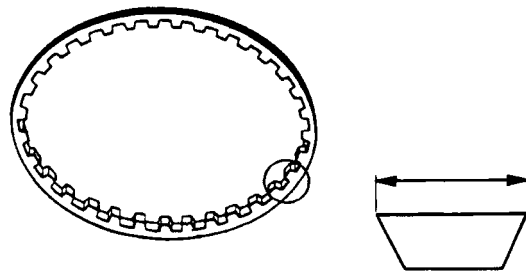

\* Use specified genuine parts for replacement.

## CLUTCH OUTER INSPECTION

Inspect the clutch outer for wear or damage.  
 Measure the clutch outer I.D.

### Service Limit:

Mongoose/KXR 90: 112.5mm

Mongoose/KXR 50: 107.5mm



## 9. DRIVE AND DRIVEN PULLEYS

### CLUTCH/DRIVEN PULLEY DISASSEMBLY

Hold the clutch/driven pulley assembly with the clutch spring compressor.

- \* Be sure to use a clutch spring compressor to avoid spring damage.

Special

Clutch Spring Compressor E034

Set the clutch spring compressor in a vise and remove the clutch drive plate nut.

Loosen the clutch spring compressor and disassemble the clutch/driven pulley assembly.

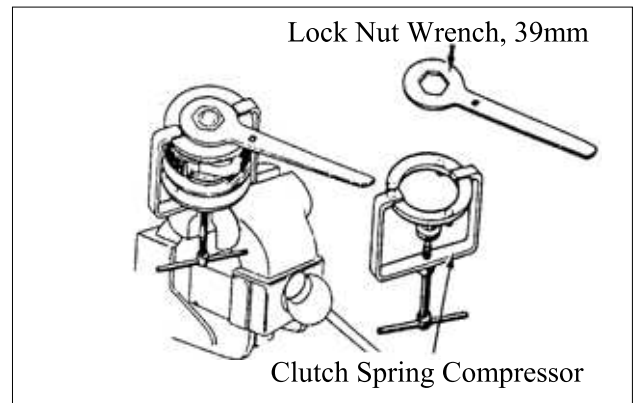

Remove the seal collar.



Pull out the three guide roller pins and guide rollers. Remove the movable driven face from the driven face.

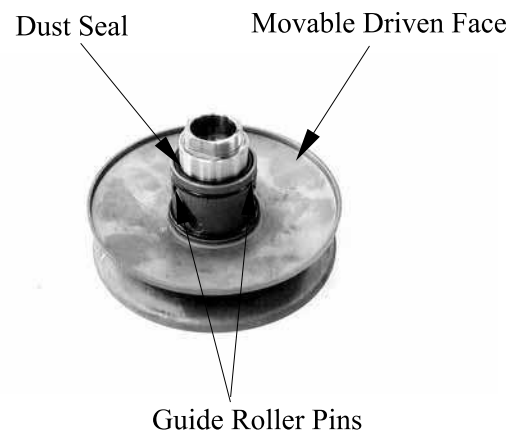

## 9. DRIVE AND DRIVEN PULLEYS

Mongoose/KXR 90/50

Measure the clutch lining thickness.

**Service Limit:**

Mongoose/KXR 90: 1.5mm replace if below

Mongoose/KXR 50: 1.0mm replace if below

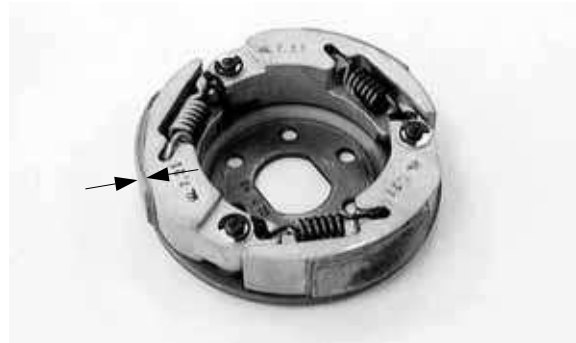

**INSPECTION**

Measure the driven face spring free length.

**Service Limit:**

Mongoose/KXR 90: 137.5mm below

Mongoose/KXR 50: 92.8mm below

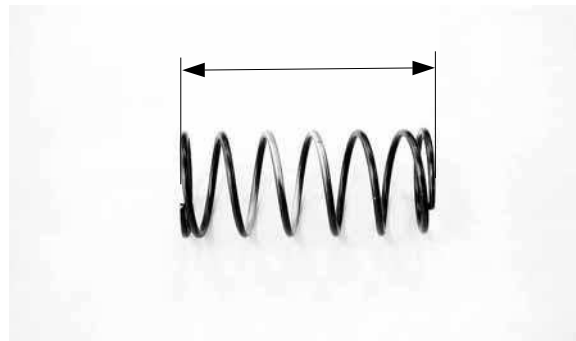

Check the driven face for wear or damage.

Measure the driven face O.D.

**Service Limit:** 33.94mm below



## 9. DRIVE AND DRIVEN PULLEYS

Check the movable driven face for wear or damage.  
 Measure the movable driven face I.D.  
**Service Limit:** 34.06mm over

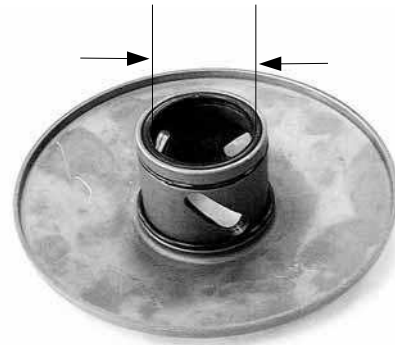

### DRIVEN PULLEY FACE BEARING REPLACEMENT

Drive the inner needle bearing out of the driven pulley face.

\* Discard the removed bearing and replace with a new one.

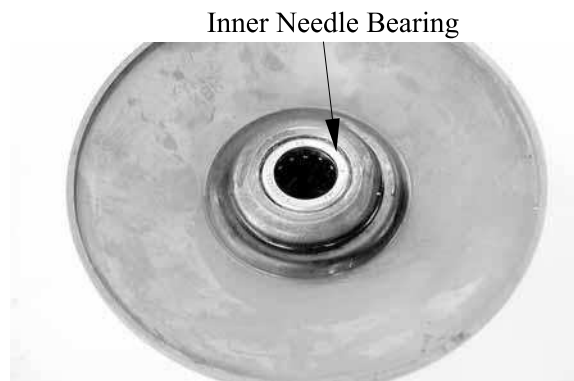

Remove the snap ring and drive the outer bearing out of the driven face.

\* Discard the removed bearing and replace with a new one.

**Special**

Bearing Puller E037

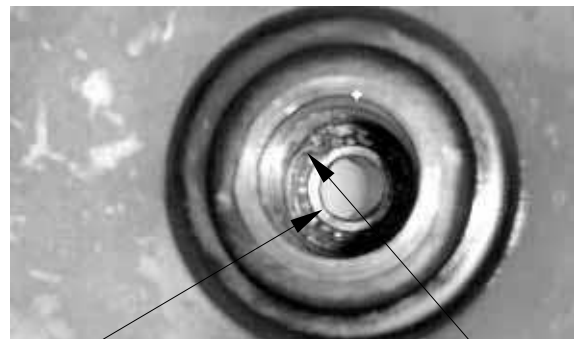

Apply grease to the outer bearing.  
 Drive a new outer bearing into the driven face with the sealed end facing up.  
 Seat the snap ring in its groove.  
 Apply grease to the driven face bore areas.

\* Pack all bearing cavities with proper grease.  
 Specified grease: Heat resistance 230°C

Press a new needle bearing into the driven face.

**Special**

Oil Seal And Bearing Install E014

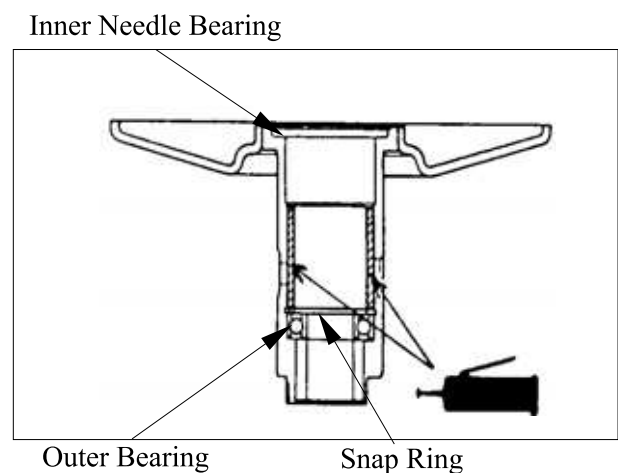



## 9. DRIVE AND DRIVEN PULLEYS

Mongoose/KXR 90/50

### CLUTCH DISASSEMBLY

Remove the circlips to disassemble the clutch.

\* Keep grease off the clutch linings.

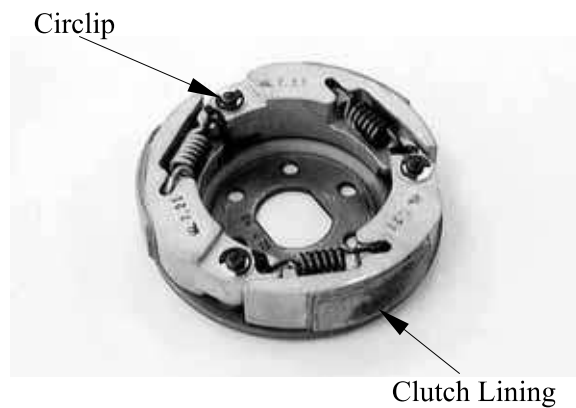

### CLUTCH / DRIVEN PULLEY ASSEMBLY

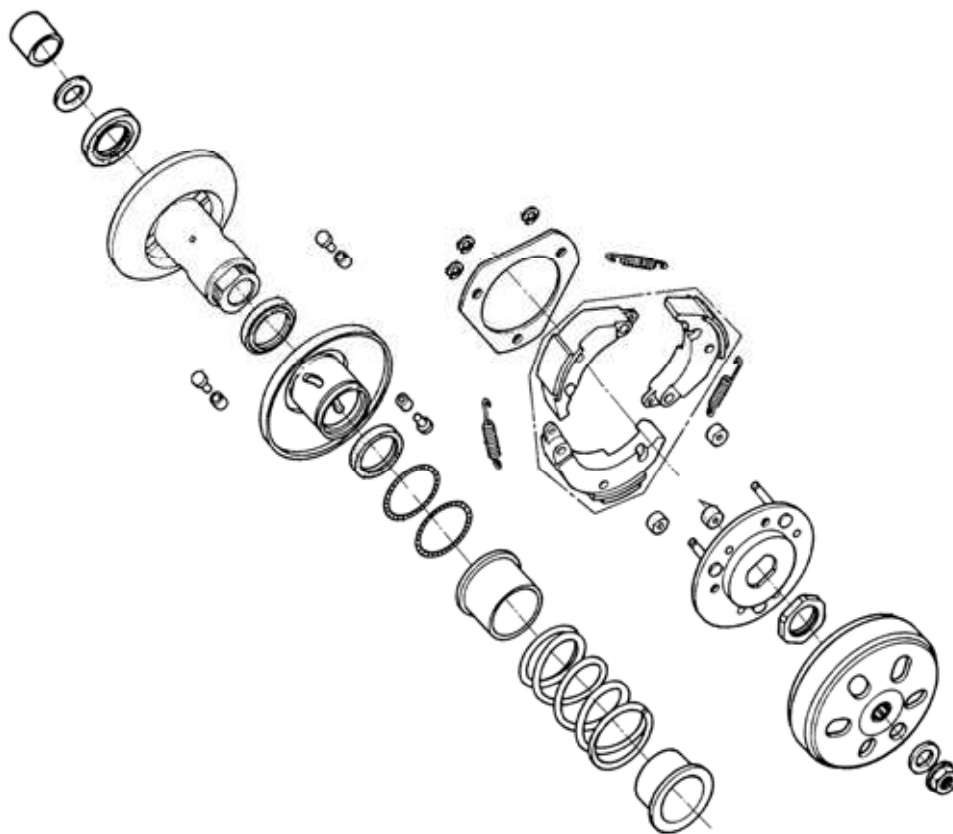

## 9. DRIVE AND DRIVEN PULLEYS

Install the damper rubbers on the drive plate pins.

Install the clutch weights/shoes and clutch springs.

Set the circlips in the groove.

Clean the driven pulley faces and remove any grease from them.

Install the oil seal onto the moveable driven face.

Apply grease onto the Oil seal and install them onto the moveable driven face.

Install the movable driven face onto the driven face.

Apply grease to the guide rollers and guide roller pins and then install them into the holes of the driven face.

Install the seal collar.

Remove any excessive grease.

\* Be sure to clean the driven face off any grease.

Set the driven pulley assembly, collar (OFF ROAD), driven face spring and clutch assembly onto the clutch spring compressor.

\* Align the flat surface of the driven face with the flat on the clutch drive plate.

Compress the clutch spring compressor and install the drive plate nut.

Set the clutch spring compressor in a vise and tighten the drive plate nut to the specified torque.

**Torque:** 5.0~6.0kgf-m

\* Be sure to use a clutch spring compressor to avoid spring damage.

**Special**

Clutch Spring Compressor E027

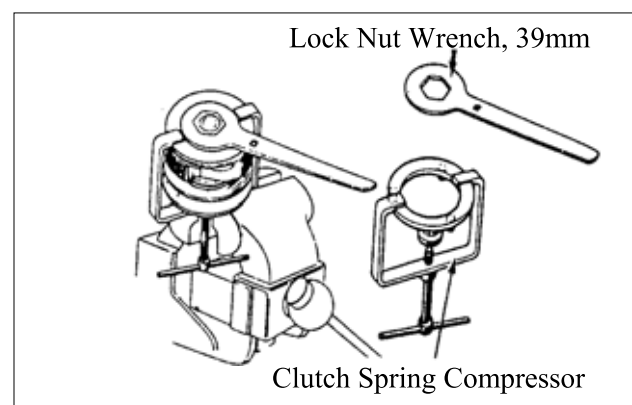
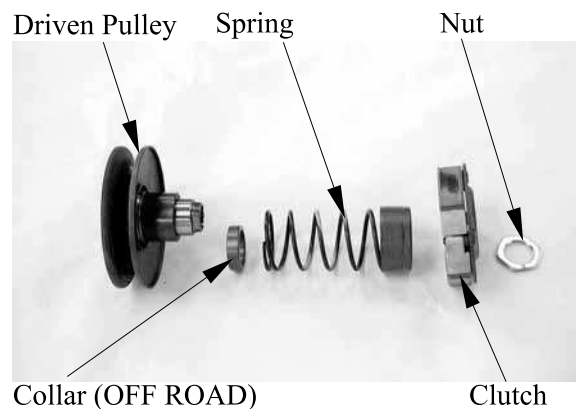

## 9. DRIVE AND DRIVEN PULLEYS

Mongoose/KXR 90/50

### INSTALLATION

Install the clutch/driven pulley and driven belt onto the drive shaft.

\* Keep grease off the drive shaft.



Install the clutch outer.  
Hold the clutch outer with the universal holder.  
Install and tighten the clutch outer nut.

**Torque:** 3.5~4.5kg-m

Special

Universal Holder    E017

# 10.FINAL REDUCTION/ TRANSMISSION SYSTEM

---

---

## FINAL REDUCTION/TRANSMISSION SYSTEM

---

SERVICE INFORMATION----- 10- 2

TRANSMISSION CASE COVER----- 10- 3

# 10.FINAL REDUCTION/ TRANSMISSION SYSTEM

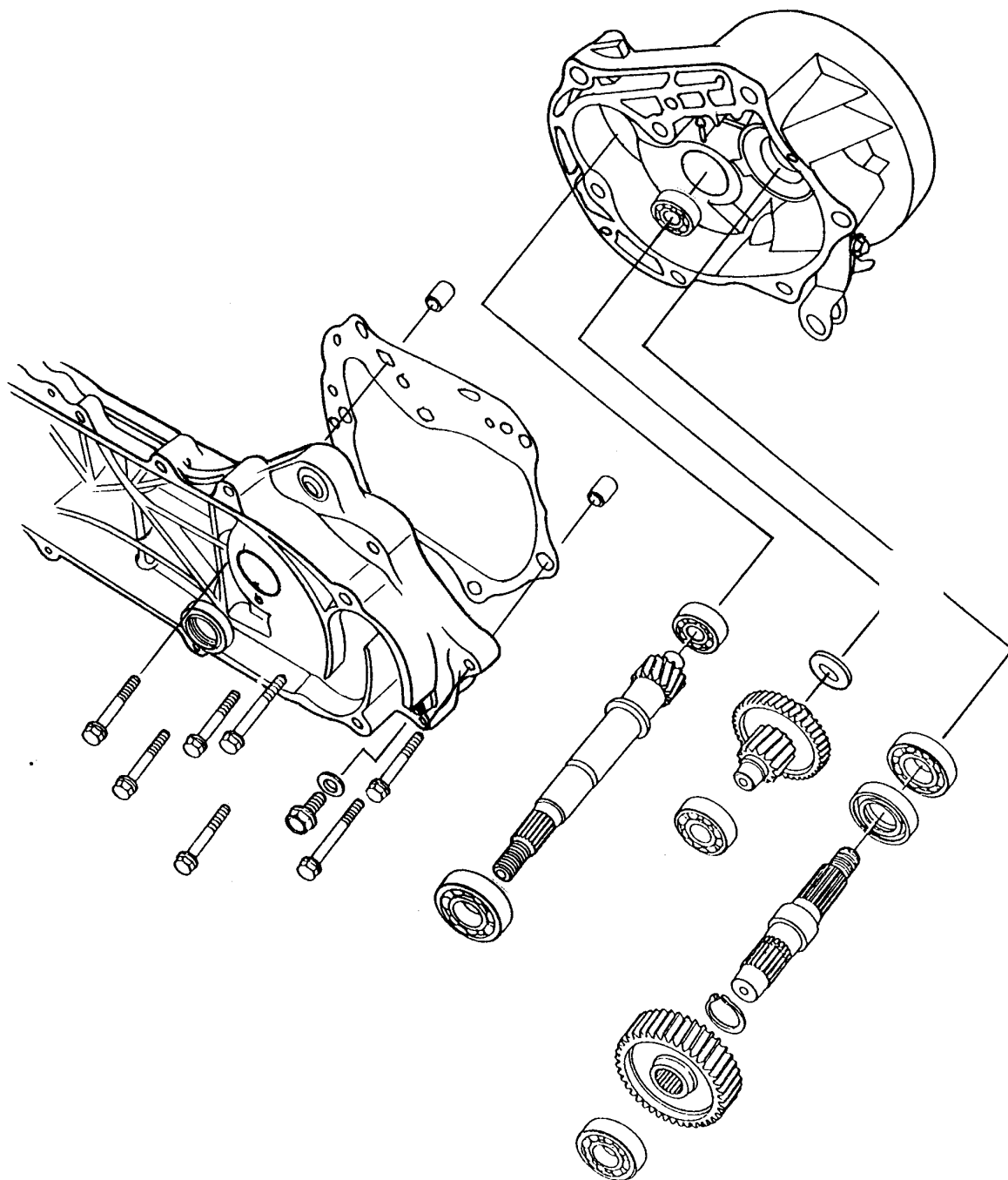

## SERVICE INFORMATION

### GENERAL INSTRUCTIONS

- The transmission system can be serviced with the engine installed in the frame.
- When replacing the drive shaft, use a special tool to hold the bearing inner race for this operation.

### SPECIFICATIONS

Specified Oil: GEAR OIL SAE 90#

Oil Capacity:       At change       : 0.11 liter  
                          At disassembly : 0.12 liter

### TORQUE VALUES

Transmission case cover bolt   2.4~3.0kgf-m

### TROUBLESHOOTING

#### Engine starts but ATV won't move

- Damaged transmission
- Seized or burnt transmission

#### Oil leaks

- Oil too rich
- Worn or damaged oil seal

# 10.FINAL REDUCTION/ TRANSMISSION SYSTEM

## TRANSMISSION CASE COVER REMOVAL

Remove the drive sprocket. (⇒6-2)  
Remove the left crankcase cover. (⇒9-2)  
Remove the clutch/driven pulley. (⇒9-10)  
Drain the transmission gear oil into a clean container.  
Remove the transmission case cover attaching bolts.  
Remove the transmission case cover.  
Remove the gasket and dowel pins.

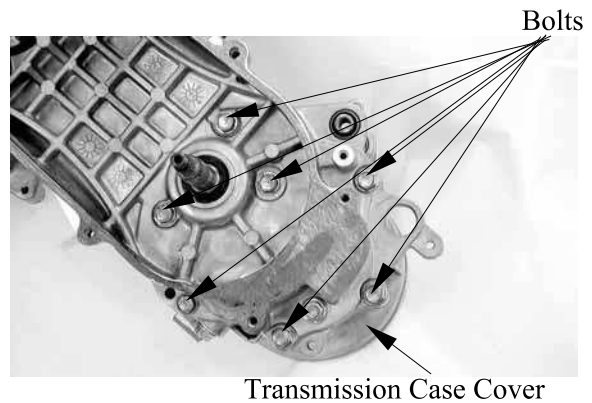

Inspect the bearings for allow play in the transmission case cover or the bearings turn roughly.  
If any defects are found, replace the bearing with a new one.  
Inspect the final shaft bearing oil seal for wear or damage.

Do not remove the transmission case cover except for necessary part replacement. When replacing the drive shaft, also replace the bearing and oil seal.

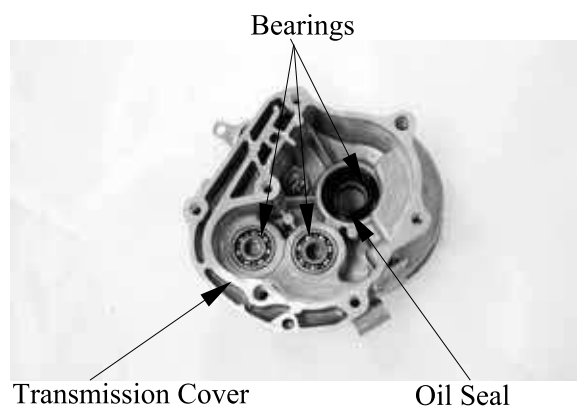

Remove the final gear and countershaft.

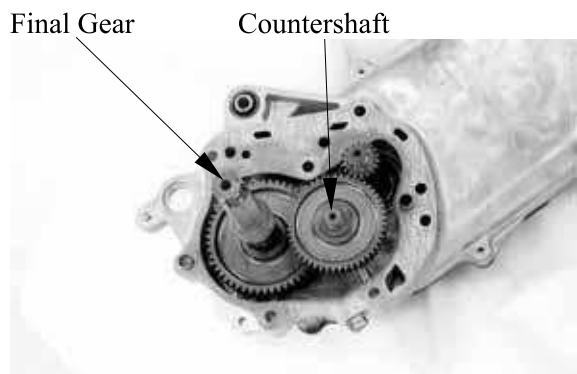

Inspect the bearings for allow play in the transmission case cover or the bearing turns roughly.  
If any defects are found, replace the bearing with a new one.

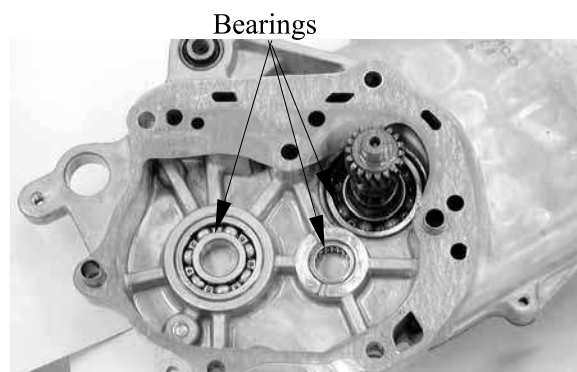

# 10.FINAL REDUCTION/ TRANSMISSION SYSTEM

## PRIMARY DRIVE AXLE REMOVAL

Remove the clutch/friven pulley. (Refer to chapter 9)

Remove the primary drive axle.

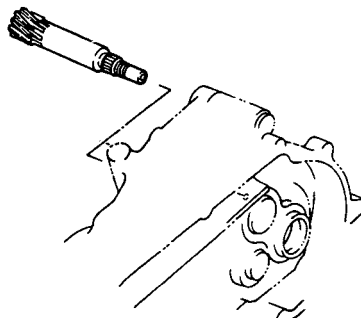

Inspect the final gear teeth.  
Blue discoloration/pitting/wear → Replace.



Inspect the countershaft gear teeth.  
Blue discoloration/pitting/wear → Replace.





# 10.FINAL REDUCTION/ TRANSMISSION SYSTEM

## INSTALLATION

Reverse the “TRANSMISSION REVOVAL” section procedures.

Install the primary drive axle into the left crankcase.

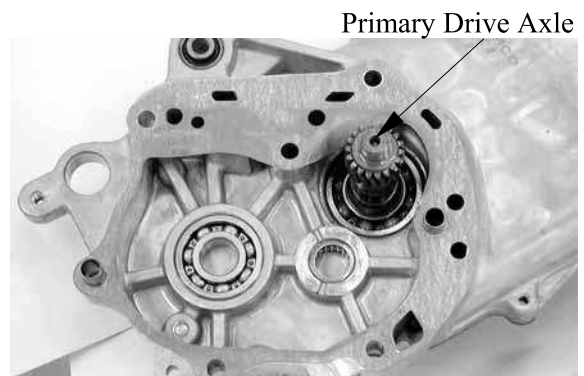

Install the final gear and final shaft into left crankcase.

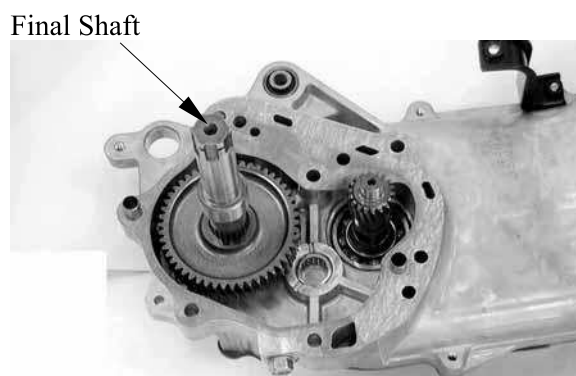

Install the countershaft and washer into the left crankcase.

Install the resin washer onto countershaft.

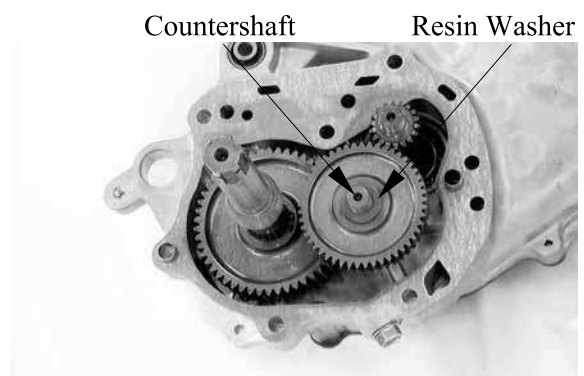

Install the dowel pins and a new gasket onto the right crankcase.

Install the transmission case cover and tighten the transmission case cover bolt.

**Torque:** 2.4~3.0kgf-m

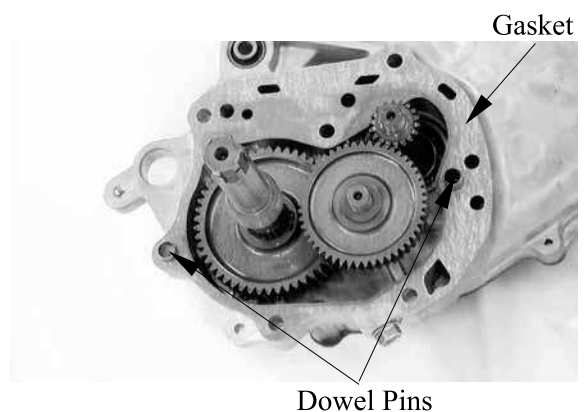

# 10.FINAL REDUCTION/ TRANSMISSION SYSTEM

---

Fill the engine with oil and install the oil filler bolt. (Refer to the “TRANSMISSION OIL REPLACEMENT” section in the chapter 3)

**Specified Gear Oil:**

KYMCO SIGMA GEAR OIL 90#

**Oil Capacity:**

At disassembly : 0.12 liter

At change : 0.11liter

---

---

---

---

---

---

---

---

## CRANKCASE/CRANKSHAFT

---

SERVICE INFORMATION-----	11- 3
CRANKCASE/CRANKSHAFT (Mongoose/KXR 90)-----	11- 4
CRANKCASE/CRANKSHAFT (Mongoose/KXR 50)-----	11- 7

# 11. CRANKCASE/CRANKSHAFT

Mongoose/KXR 90

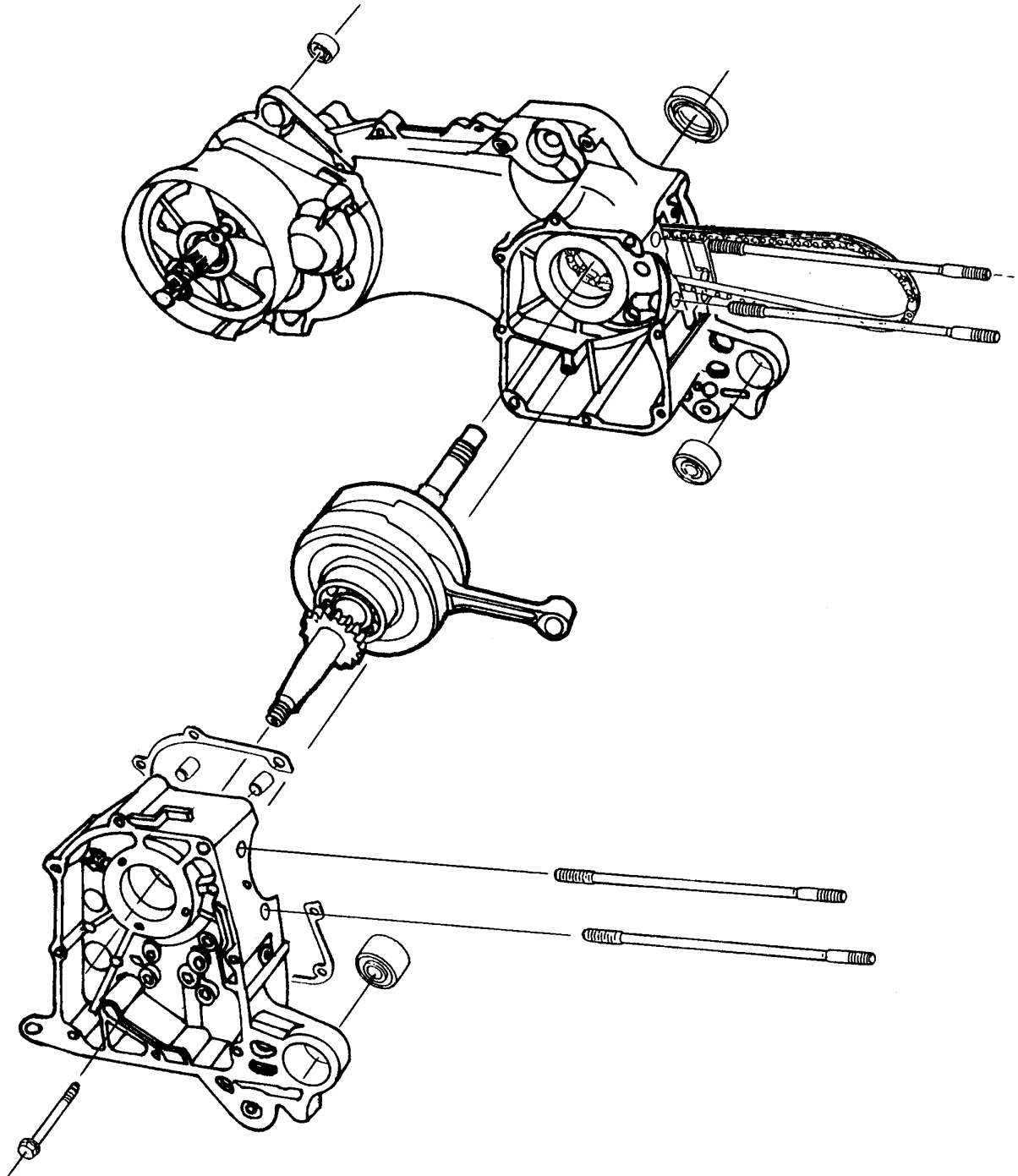

# 11. CRANKCASE/CRANKSHAFT

**Mongoose/KXR 50**

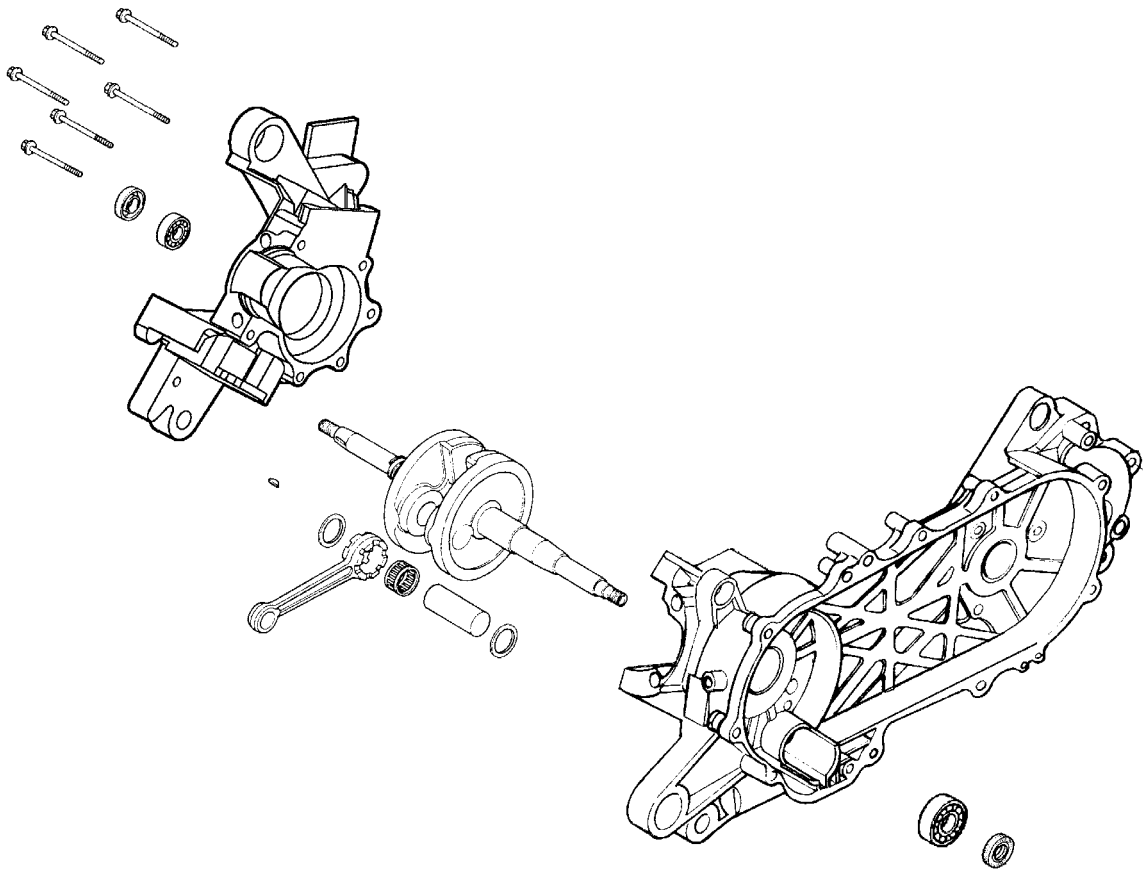

## SERVICE INFORMATION

### GENERAL INSTRUCTIONS

- This section covers crankcase separation to service the crankshaft. The engine must be removed for this operation.
- The following parts must be removed before separating the crankcase.
  - Cylinder head (⇒Chapter 7 (Mongoose/KXR 90))
  - Cylinder/piston (⇒Chapter 8)
  - Drive and driven pulleys (⇒Chapter 9)
  - A.C. generator (⇒Chapter 14)
  - Starter clutch (⇒Chapter 16)
  - Oil pump (⇒Chapter 4)

### SPECIFICATIONS (Mongoose/KXR 90)

	Item	Standard (mm)	Service Limit (mm)
Crankshaft	Connecting rod small end free play	0.05~0.4	0.6
	Connecting rod big end radial clearance	0~0.008	0.05
	Run out	—	0.10

### SPECIFICATIONS (Mongoose/KXR 50)

	Item	Standard (mm)	Service Limit (mm)
Crankshaft	Connecting rod big end side clearance	—	0.6
	Connecting rod big end radial clearance	—	0.04
	Run out A/B	—	0.1/0.15

### TORQUE VALUES

- Crankcase bolt                                    0.8~1.2kgf-m  
 Cam chain tensioner slipper bolt            0.8~1.2kgf-m (Mongoose/KXR 90)

### SPECIAL TOOLS (Mongoose/KXR 50)

- Crankcase puller                                E026  
 Universal bearing puller                      E030  
 Crankshaft install tool                        E016  
 Crankcase assembly tool                      E024  
 Oil seal and bearing install tool            E014

### TROUBLESHOOTING

#### Abnormal engine noise

- Excessive crank journal bearing play
- Excessive crankpin bearing play
- Excessive transmission bearing play

## CRANKCASE/CRANKSHAFT (Mongoose/KXR 90)

### REMOVAL

Remove the crankcase attaching bolt.  
Separate the left and right crankcase halves.

- Do not damage the crankcase gasket surface.
- Never use a driver to pry the crankcase mating surfaces apart.

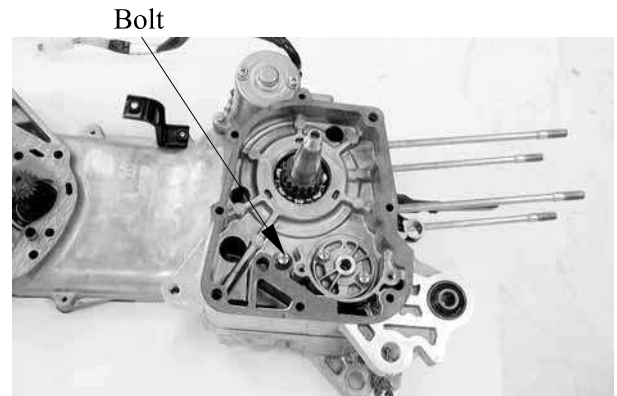

Remove the crankshaft from the left crankcase.



Remove the cam chain.  
Remove the gasket and dowel pins.

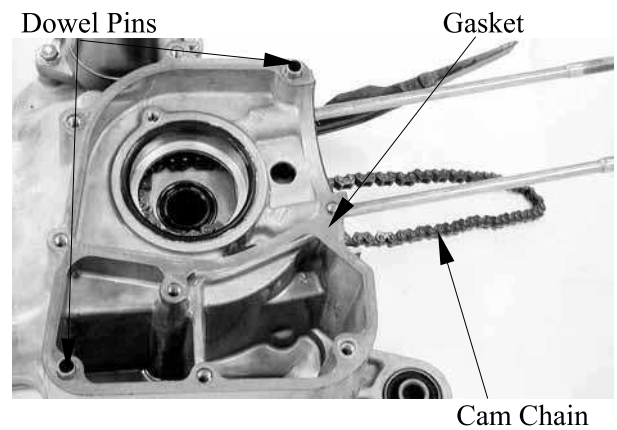

Clean off all gasket material from the crankcase mating surfaces.

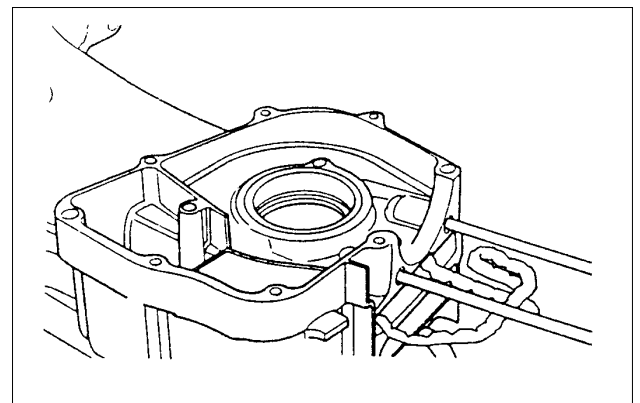

## CRANKSHAFT INSPECTION

Measure the connecting rod small end I.D.

**Service Limit:** 13.06 mm replace if over



Measure the connecting rod small end free play (A).

Out of specification (0.05 ~ 0.4 mm) →  
Replace the crankshaft.

Measure the crankshaft run out (B).

**Service Limit:** 0.10mm replace if over

Measure the connecting rod big end side clearance (C).

**Service Limit:** 0.05mm replace if over

Measure the crank width (D).

Out of specification (45.15 ~ 45.2 mm) →  
Replace the crankshaft.

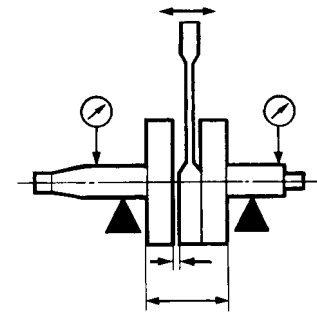

Turn the crankshaft bearings and check for excessive play.

Measure the crankshaft bearing play.

**Service Limit:**

Axial : 0.20mm replace if over

Radial : 0.05mm replace if over

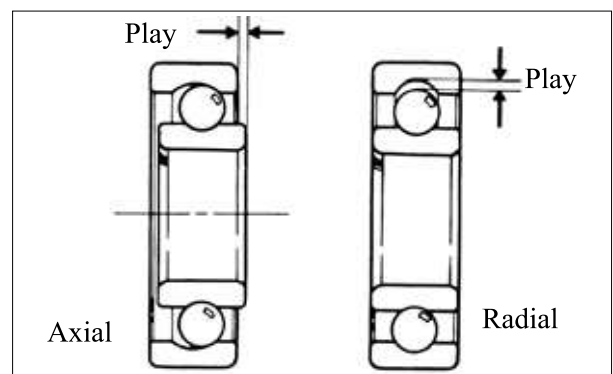



# 11.CRANKCASE/CRANKSHAFT

## CRANKCASE/BALANCER INSTALLATION

Install the cam chain into the left crankcase.

Install the dowel pins and a new gasket onto the left crankcase.

Place the right crankcase over the crankshaft and onto the left crankcase.



Install the crankshaft into the left crankcase.

When installing the crankshaft, be careful not to damage the oil seal.



Install the right crankcase.  
Tighten the crankcase attaching bolt.  
**Torque:** 0.8~1.2kgf-m



# 11.CRANKCASE/CRANKSHAFT

## CRANKCASE/CRANKSHAFT (Mongoose/KXR 50)

### REMOVAL

Remove the crankcase attaching bolts.

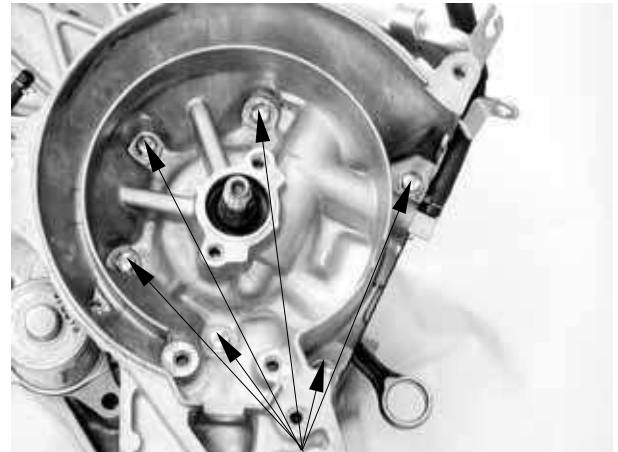

Bolt

Attach the crankcase puller on the right crankcase and remove the right crankcase from the left crankcase.



Crankcase puller

E026

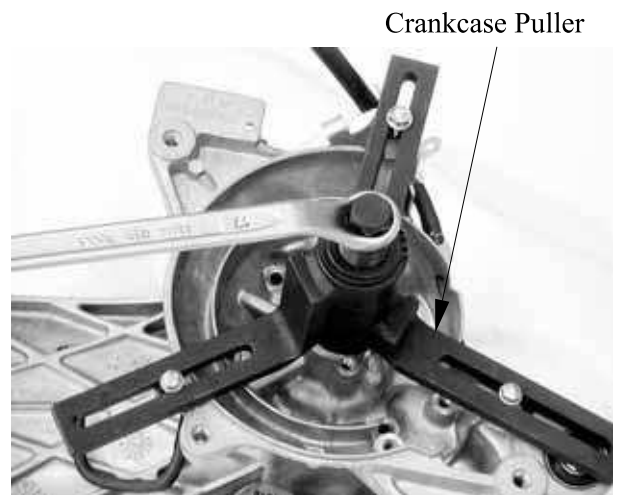

Crankcase Puller

### CRANKSHAFT REMOVAL

Attach the crankcase puller on the left crankcase and remove the crankshaft from the left crankcase.

- \* 

When removing the crankshaft, do it slowly and gently.



Crankcase puller

E026

- \* 

When separating the crankcase, the oil seals must be removed. Replace the oil seals with new ones.



Crankcase Puller

# 11.CRANKSCASE/CRANKSHAFT

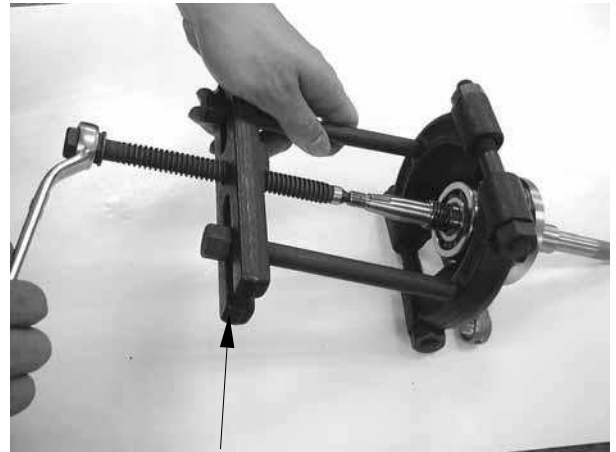

r

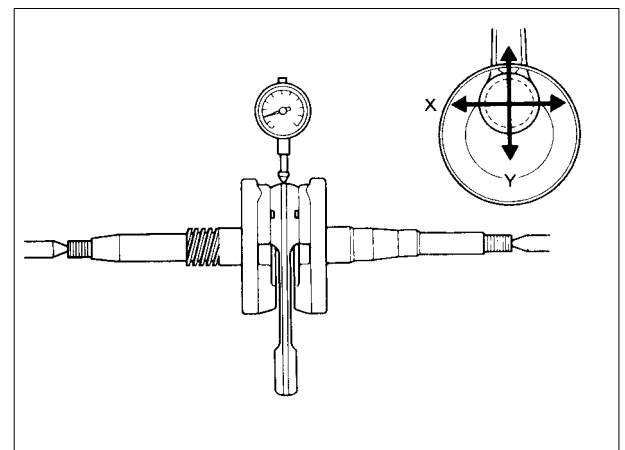
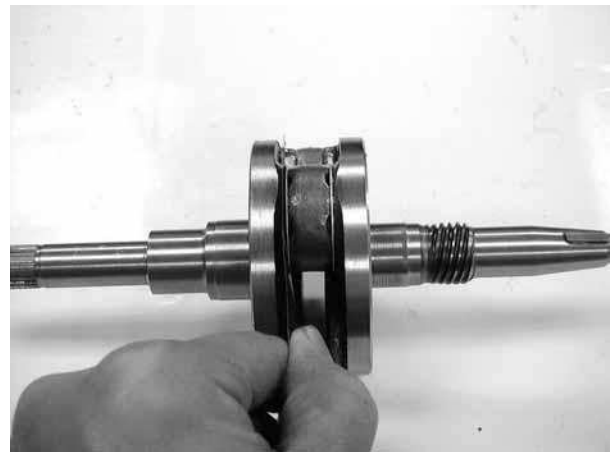

Measure the crankshaft runout.

Service Limit	
A	B
0.100mm replace if over	0.150mm replace if over

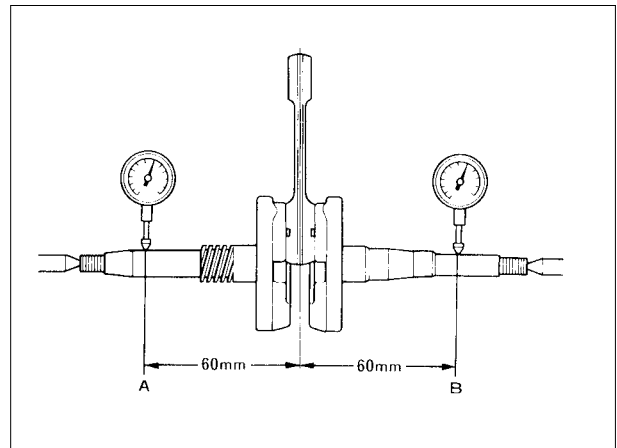

Check the crankshaft bearings for excessive play. The bearings must be replaced if they are noisy or have excessive play.

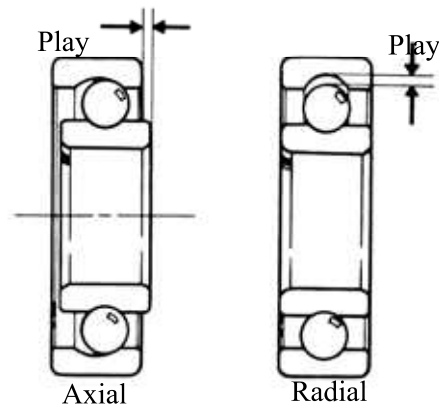

## CRANKSHAFT INSTALLATION

Wash the crankshaft in cleaning solvent and then check for cracks or other faults.

\*

- After check, apply clean engine oil to all moving and sliding parts.
- Remove all gasket material from the crankcase mating surfaces. Dress any roughness or irregularities with an oil stone.

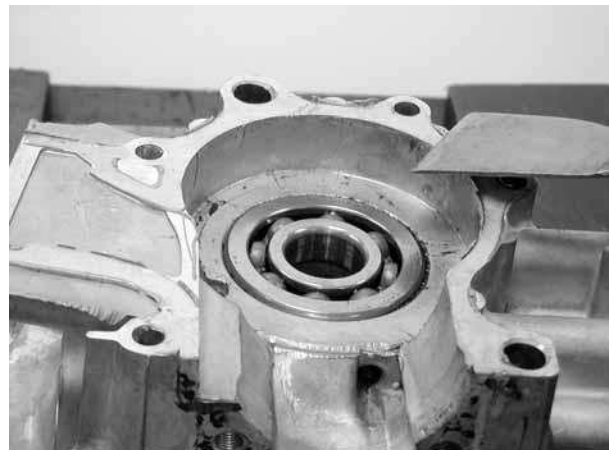

# 11.CRANKSCASE/CRANKSHAFT

Drive a new crankshaft bearing into the right crankcase.



Oil seal and bearing install E014

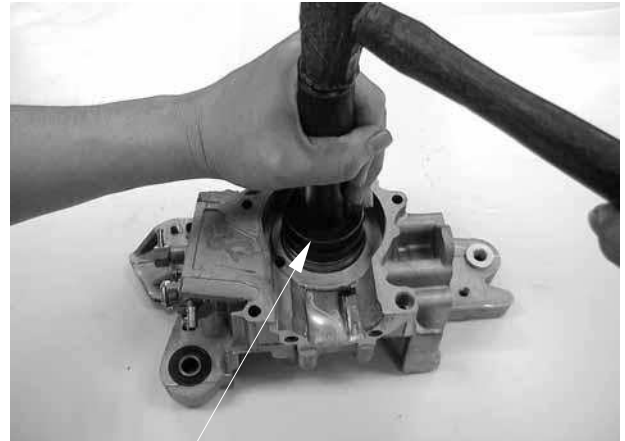

Oil Seal And Bearing Install

Drive a new crankshaft bearing into the left crankcase.



Oil seal and bearing install E014



Install the crankshaft into the left crankcase.

\*

Apply molybdenum disulfide to the crankshaft bearings and connecting rod big end.

- Apply grease to the lip of the oil seal and then install it.



Crankshaft install tool E016



Crankcase Install Tool

# 11.CRANKCASE/CRANKSHAFT

## CRANKCASE ASSEMBLY

Install the dowel pins and a new gasket to the crankcase mating surface.

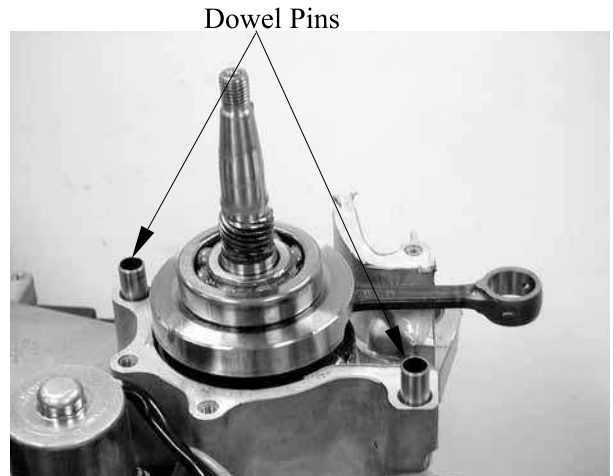

Assemble the crankcase halves.



Crankshaft & crankcase install tool E024

The distance between the right crankcase oil seal and crankcase surface is about  $12.5 \pm 0.5$  mm.

\*

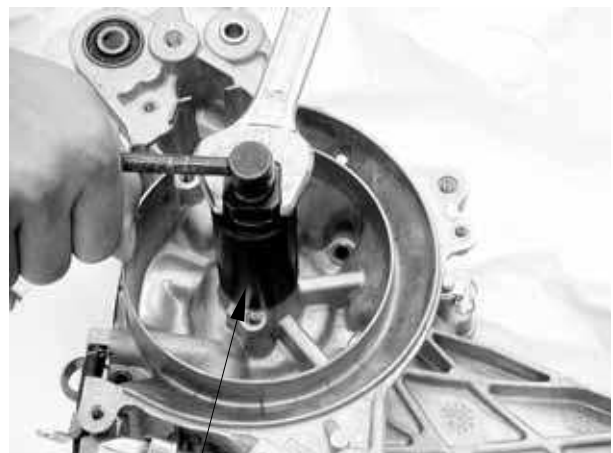

Crankshaft & Crankcase Install Tool

# 11.CRANKSCASE/CRANKSHAFT

The distance between the left crankcase oil seal and crankcase surface is about 1.0mm.

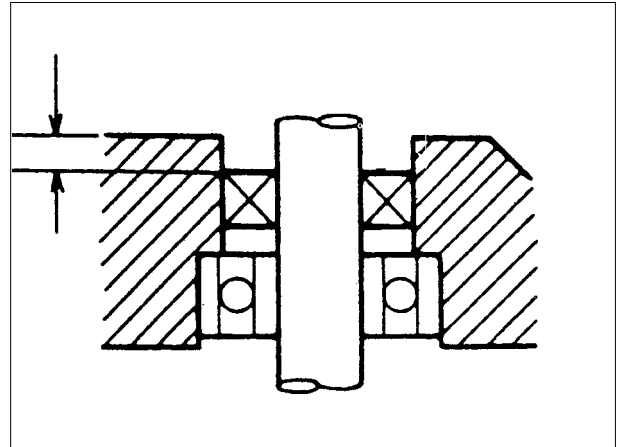

Install and tighten the crankcase attaching bolts.

\*



---

---

---

---

---

---

---

**FRONT WHEEL/FRONT BRAKE/  
FRONT SUSPENSION\STEERING SYSTEM**

---

SERVICE INFORMATION-----	12- 2
FRONT WHEEL-----	12- 4
FRONT BRAKE-----	12- 8
FRONT SUSPENSION-----	12-10
STEERING SYSTEM-----	12-13
TIE-ROD-----	12-17



# 12. FRONT WHEEL/Front BRAKE/Front SUSPENSION/STEERING SYSTEM



Mongoose/KXR 90/50

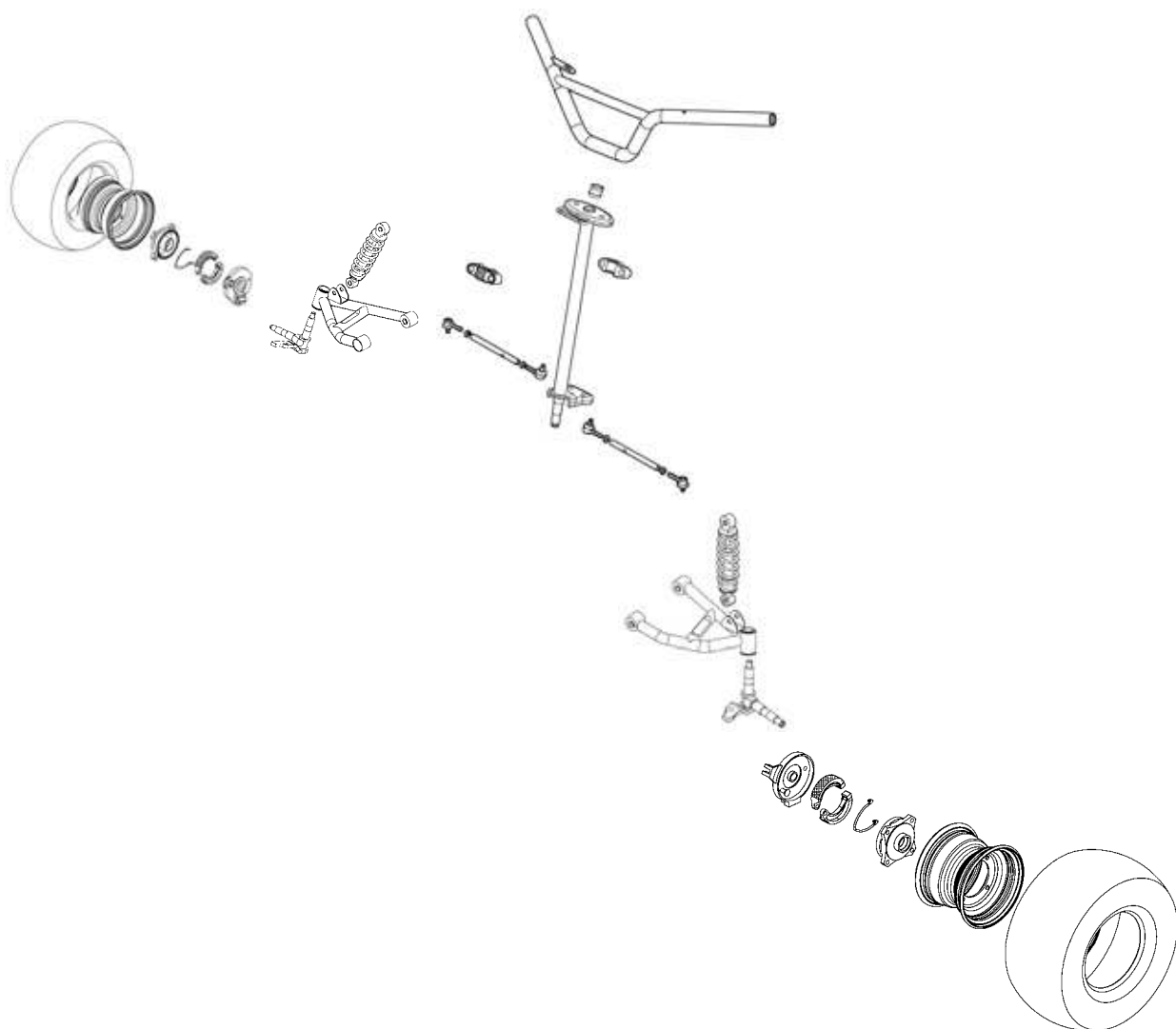

# 12. FRONT WHEEL/FRONT BRAKE/FRONT SUSPENSION/STEERING SYSTEM



Mongoose/KXR 90/50

## SERVICE INFORMATION

### GENERAL INSTRUCTIONS

- Remove the machine frame covers before removing the front wheel. Jack the machine front wheel off the ground and be careful to prevent the machine from falling down.
- During servicing, keep oil or grease off the brake drum and brake linings.
- Inspect the brake system before riding.

### SPECIFICATIONS

Item		Standard (mm)	Service Limit (mm)
Front wheel rim run out	Radial	—	2.0
	Axial	—	2.0
Front brake drum I.D		85~85.5	84
Front brake lining thickness		4.0	2.0
Tie rod length		254.5~255.5	—
Rod-end (tie rod) angle		15°±3°	—

### TORQUE VALUES

Steering stem nut	6.0~8.0kgf-m
Swing arm nut	4.0~5.0kgf-m
Front wheel nut	4.0~5.0kgf-m
Front wheel hub nut	5.5~6.5kgf-m
Front shock absorber upper mount bolt	3.5~4.5kgf-m
Front shock absorber lower mount bolt	3.5~4.5kgf-m

## SPECIAL TOOLS

Oil seal and bearing install E014

## TROUBLESHOOTING

### Hard steering (heavy)

- Insufficient tire pressure

### Steers to one side or does not track straight

- Uneven front shock absorbers
- Bent front arm
- Bent steering knuckle

### Poor brake performance

- Incorrectly adjusted brake
- Worn brake linings
- Contaminated brake lining surface
- Worn brake shoes at cam contacting area
- Worn brake drum
- Poorly connected brake arm

### Front wheel wobbling

- Bent rim
- Excessive wheel bearing play
- Bent spoke plate
- Faulty tire
- Improperly tightened axle nut

### Soft front shock absorber

- Weak shock springs
- Insufficient damper oil

### Front shock absorber noise

- Slider bending
- Loose arm fasteners
- Lack of lubrication

# 12. FRONT WHEEL/FRONT BRAKE/FRONT SUSPENSION/STEERING SYSTEM

## FRONT WHEEL

### REMOVAL

Place the machine on a level place.  
Remove four nuts attaching the wheel panel and front wheel.  
Elevate the front wheels by placing a suitable stand under the frame.

\* Support the machine securely so there is no danger of it falling over.

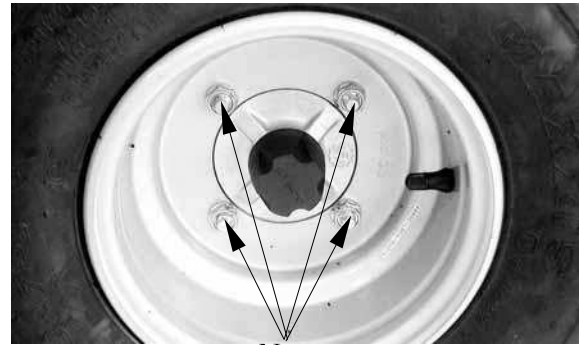

Nuts

Remove the nut cover.  
Remove the cotter pin.  
Remove nut attaching the wheel hub and washer.

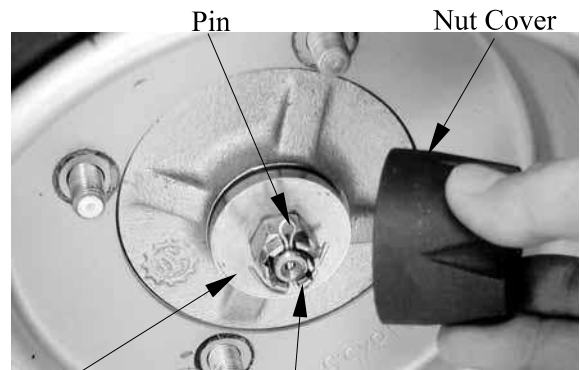

Washer

Hub Nut

Remove the collar and wheel hub.

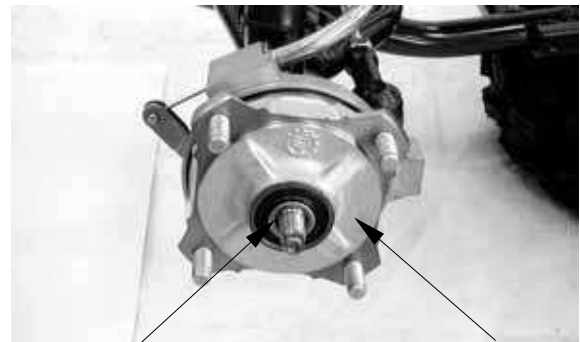

Collar

Wheel Hub

## 12. FRONT WHEEL/FRONT BRAKE/FRONT SUSPENSION/STEERING SYSTEM



Mongoose/KXR 90/50

### INSPECTION

Measure the wheel run out.

Replace wheel or check bearing play if out of specification

#### Rim run out limits:

Vertical: 2.0mm

Lateral: 2.0mm

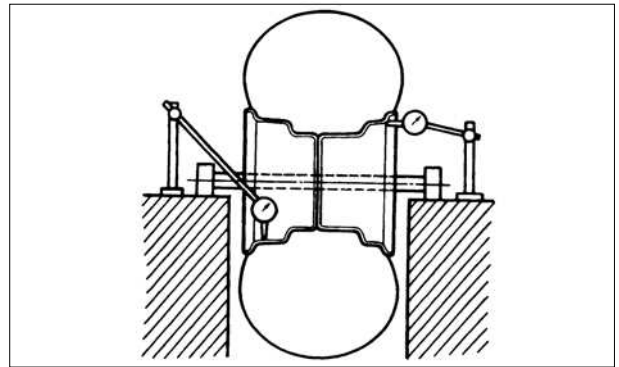

Inspect the front wheel hub.

Replace it if cracks or damage.

Inspect the front brake drum.

Measure the front brake drum I.D.

**Service limits:** 84mm

\*

Keep oil or grease off the brake drum.

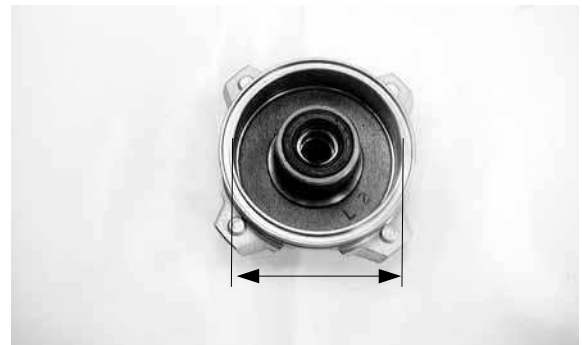

Turn the inner race of each bearing with your finger to see if they turn smoothly and quietly. Also check if the outer race fits tightly in the hub.

Replace the bearings if the races do not turn smoothly, quietly, or if they fit loosely in the hub.

# 12. FRONT WHEEL/Front BRAKE/Front SUSPENSION/STEERING SYSTEM



Mongoose/KXR 90/50

## FRONT WHEEL HUB DISASSEMBLY

Remove the side collar.



Remove the dust seal of each side.

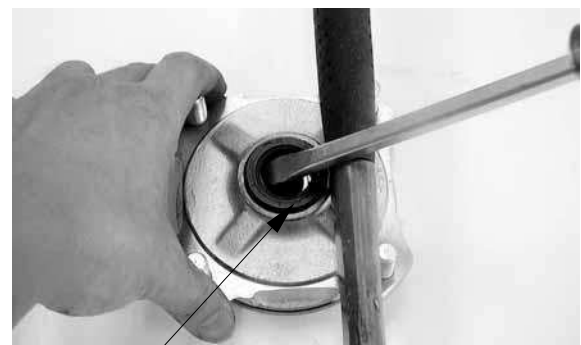

Remove the front wheel hub bearings and distance collar.

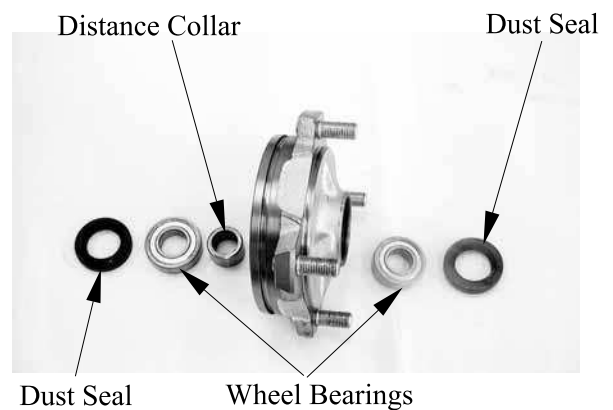

## 12. FRONT WHEEL/FRONT BRAKE/FRONT SUSPENSION/STEERING SYSTEM



Mongoose/KXR 90/50

### ASSEMBLY

Apply grease to a new dust seal lip and install the dust seal.

Pack all bearing cavities with grease.  
Drive in the left bearing.  
Install the distance collar.  
Drive in the right bearing.

- \* Do not allow the bearings to tilt while driving them in.
- \* Drive in the bearing squarely with the sealed end facing out.

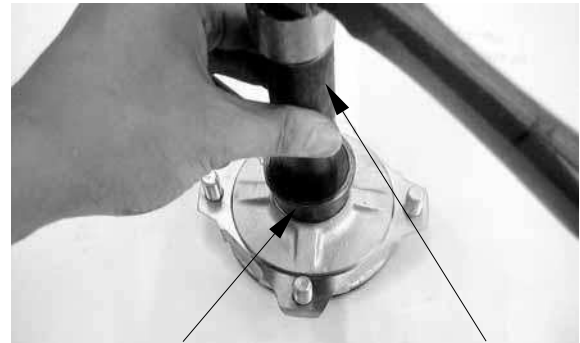

Outer Driver

Driver Handle



Oil seal and bearing install E014

### INSTALLATION

Reverse the “FRONT WHEEL REMOVAL” procedures.

Apply the grease onto the bearings and oil seal lips of the wheel hub.  
Install wheel hub, side collar, washer and tight the nut (wheel hub).

**Torque:** 5.5~6.5kgf-m

Install cotter pins and nut cover.

- \* Always use a new cotter pin.

\*

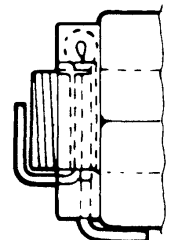
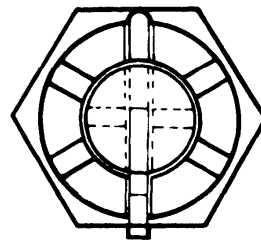

Install the front wheel and tighten the nuts (wheel).

**Torque:** 4.0~5.0kgf-m



## 12. FRONT WHEEL/FRONT BRAKE/FRONT SUSPENSION/STEERING SYSTEM



Mongoose/KXR 90/50

### FRONT BRAKE

#### REMOVAL

Remove the wheel hub. (See page 12-4)

Pull brake shoe plate out from steering knuckle.

Disconnect the front brake cable from brake cam lever and remove the brake shoe plate.

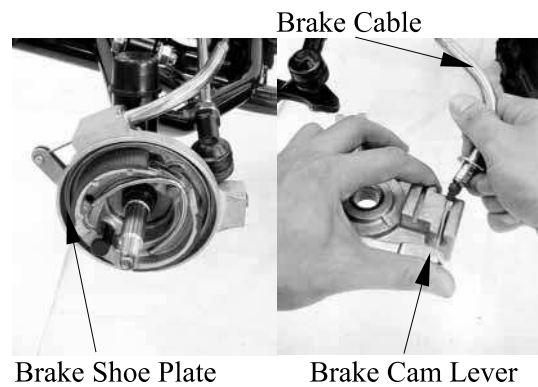

#### INSPECTION

Measure the front brake lining thickness (A).

**Service limit:** 2.0mm replace it if below

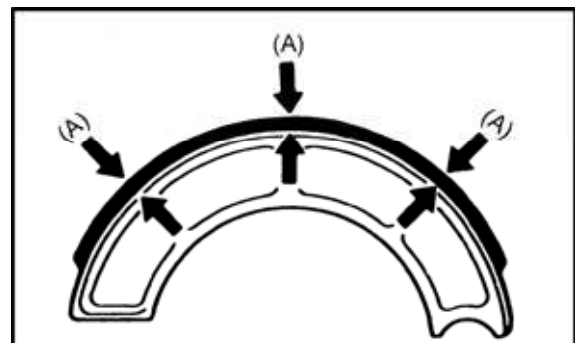

#### DISASSEMBLY

Remove return ring.

Remove the brake shoes.

#### ASSEMBLY

Reverse the “DISASSEMBLY” procedures.

\* Keep oil or grease off the brake linings.

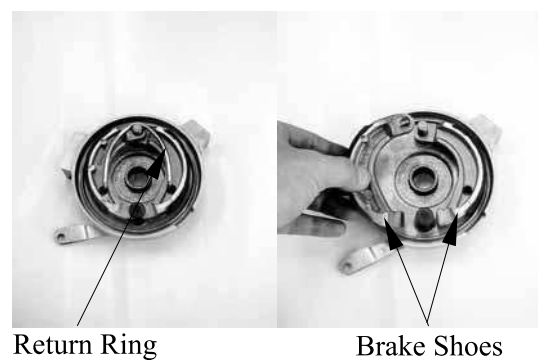



## 12. FRONT WHEEL/Front BRAKE/Front SUSPENSION/STEERING SYSTEM



Mongoose/KXR 90/50

Install the brake shoe plate.

\*

Make sure that the boss on the knuckle correctly engages with the locating slot on the brake shoe plate.

Install front wheel. (See page 12-7)

Adjust the front brake cable free play.  
Refer to the “BRAKE LEVER FREE PLAY” section in the CHAPTER 3.

**Brake cable free play:** 10~20mm



Boss

Locating Slot

# 12. FRONT WHEEL/FRONT BRAKE/FRONT SUSPENSION/STEERING SYSTEM



Mongoose/KXR 90/50

## FRONT SUSPENSION

### REMOVAL

Elevate the front wheels by placing a suitable stand under the frame.

\*

Support the machine securely so there is no danger of it falling over.

Remove the front wheel, wheel hub, brake shoe plate. (Refer to chapter 12)  
Remove the upper and lower bolt, then remove the shock absorber.

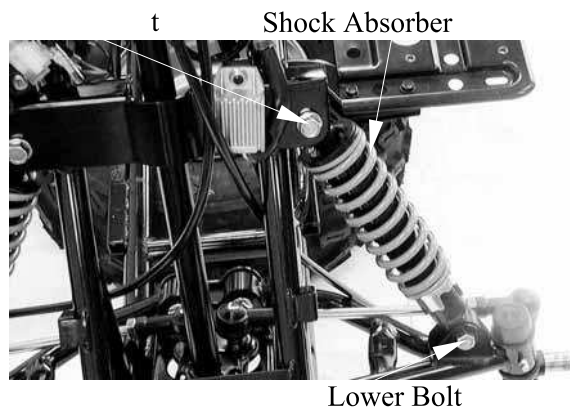

Remove the cotter pin and nut attaching the tie-rod and steering knuckle.  
Remove nut cover at the front arm.  
Remove the cotter pin and nut attaching the front arm and steering knuckle.  
Remove steering knuckle.

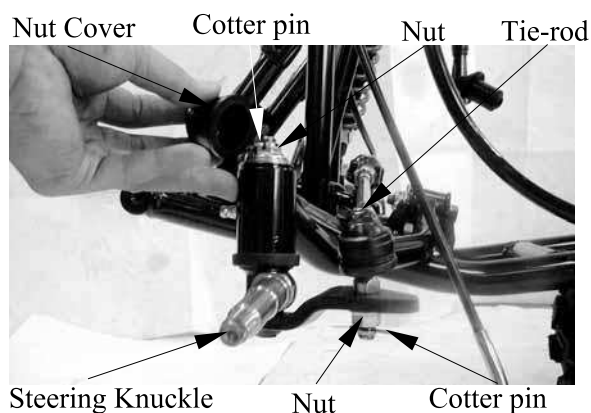

### INSPECTION

Inspect the shock absorber rod.  
Replace the shock absorber assembly if bends or damage.  
Inspect the shock absorber.  
Replace the shock absorber assembly if oil leaks.  
Inspect the spring of the shock absorber by move the spring up and down.  
Replace the shock absorber assembly if fatigue.

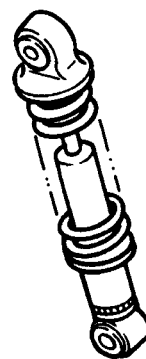

Inspect the steering knuckle.  
Replace if cracks, pitting or damage.



## 12. FRONT WHEEL/FRONT BRAKE/FRONT SUSPENSION/STEERING SYSTEM



Mongoose/KXR 90/50

Check the front arm brackets of the frame.

If bent, cracked or damaged, repair or replace the frame.

Check the tightening torque of the front arms securing nuts.

**Torque:** 4.0~5.0kgf-m

Check the dust seal.

If wear or damage, replace the dust seal.

Check the front arm side play by moving it from side to side.

If side play noticeable, replace the bushings.

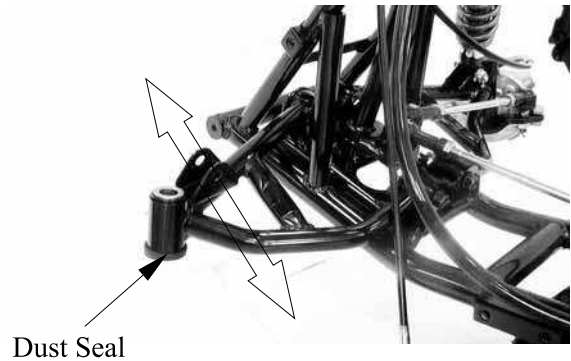

Check the front arm vertical movement by moving it up and down.

If vertical movement is tight, binding or rough, then replace the bushings.

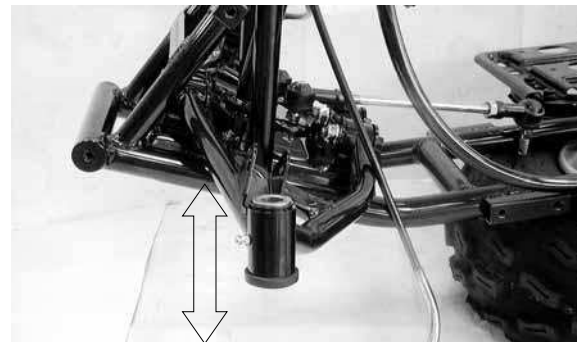

Remove the two bolts and nut attaching the front arm.

Remove the front arm.

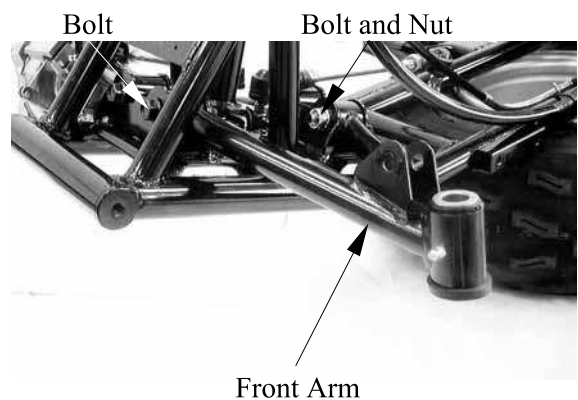

## 12. FRONT WHEEL/FRONT BRAKE/FRONT SUSPENSION/STEERING SYSTEM



Mongoose/KXR 90/50

Inspect the front arm.

Replace if cracks, bends or damage.

\*

Do not attempt to straighten a bent arm, this may dangerously weaken the arm.

Inspect bushes.

Replace if wear or damage.

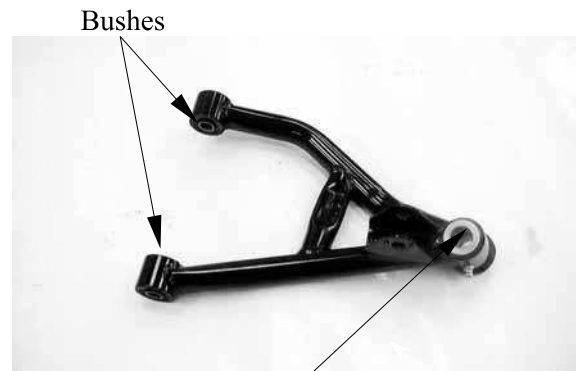

Bushes

### INSTALLATION

Reverse the "REMOVAL" procedures.

\*

Apply the grease onto the bushes.

Install the front arm onto the frame and tighten the bolts and nut.

**Torque:** 4.0~5.0kgf-m

\*

Apply the grease onto the bushes.

Install the steering knuckle into the front arm and tighten the bolt and nut.

**Torque:** 4.0~5.0kgf-m

Install the cotter pin and band ends of cotter pin.

\*

Always use a new cotter pin.

Install the tie-rod into the steering knuckle and tighten the nut.

**Torque:** 2.0~3.0kgf-m

Install the cotter pin and band ends of cotter pin.

\*

Always use a new cotter pin.

# 12. FRONT WHEEL/FRONT BRAKE/FRONT SUSPENSION/STEERING SYSTEM



Mongoose/KXR 90/50

## STEERING SYSTEM

### HANDLEBAR REMOVAL

Remove the following parts:

Handlebar and Front fender.

Refer to the “FRAME COVER” section in the CHAPTER 2

### INSPECTION

Inspect the handlebar.

Replace if cracks, bends or damage.



### INSTALLATION

Install handlebar and handlebar holder, then tighten the four bolts.

**Torque:** 1.8~2.5kgf-m

- \*
  - Align the mark on the handlebar with the lower handlebar holder surface.
  - Be sure the upper handlebar holder mark face to front.
  - First tighten the bolts on the front side of the handlebar holder, and then tighten the bolts on the rear side.



Refer to the “BRAKE FREE PLAY” section in the CHAPTER 3 to adjust front brake.

**Brake cable free play:** 10~20mm

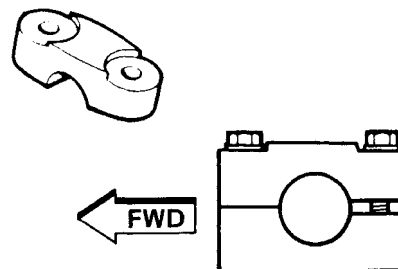

## 12. FRONT WHEEL/FRONT BRAKE/FRONT SUSPENSION/STEERING SYSTEM

### STEERING COLUMN REMOVAL

Remove handlebar. (Refer to “FRAME COVER” section in chapter 2)

Remove the cotter pins and nuts attaching the tie-rods, then remove tie-rods.

Remove the cotter pin and nut attaching the steering column, then remove steering column and collar.

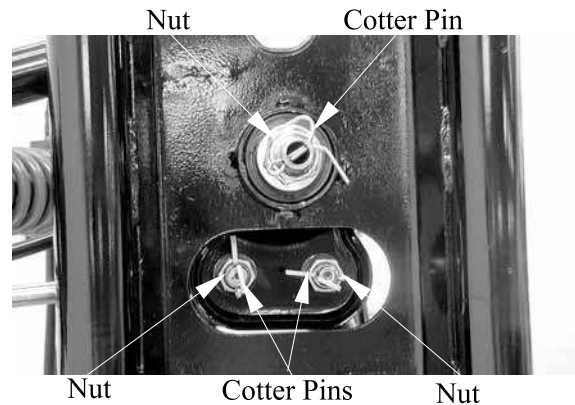

Remove the two bolts to remove the steering bracket and rubber collar.

Remove steering column and collar.

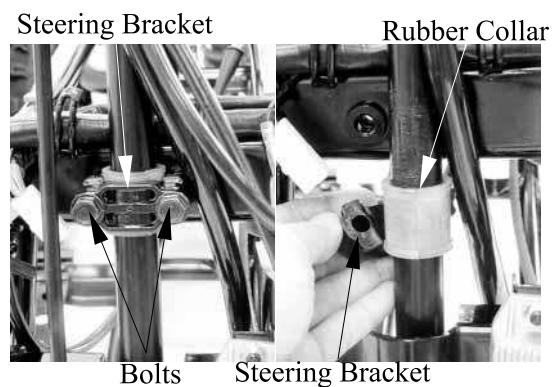

### INSPECTION

Inspect the steering column.

Replace it if bends or damage.

\* Do not attempt to straighten a bent shaft, this may dangerously weaken the shaft.

Inspect the collar.

Replace it if wear or damage.

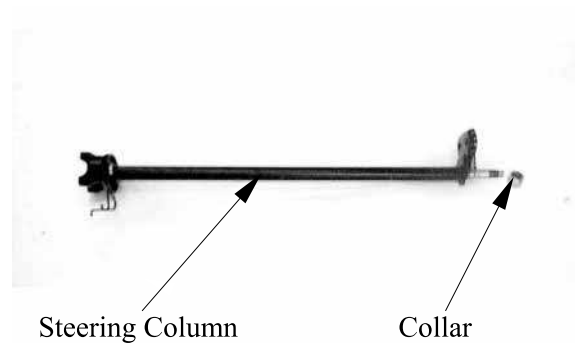

Inspect the duty seals, snap ring and bearing.

Replace them if wear or damage.



## 12. FRONT WHEEL/FRONT BRAKE/FRONT SUSPENSION/STEERING SYSTEM



Mongoose/KXR 90/50

Remove the dust seal of each frame side.

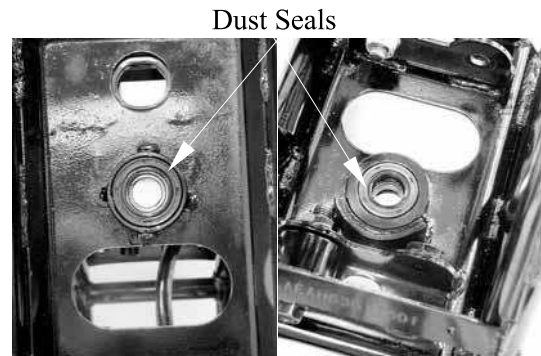

Remove the snap ring.  
Remove the bearing.



### INSTALLATION

Apply grease to a new dust seal lip and install the dust seal (under frame).

Pack bearing cavities with grease.

Drive in the bearing and install snap ring.

Apply grease to a new dust seal lip and install the dust seal.

- \* • Do not allow the bearings to tilt while driving them in.  
• Drive in the bearing squarely with the sealed end facing out.



Oil seal and bearing install E014

Apply the grease onto the bearings and oil seal lips of the frame.

Install steering column and collar, then tighten the nut.

**Torque:** 6.0~8.0kgf-m

Install cotter pins and band ends of cotter pin.

\*



## 12. FRONT WHEEL/Front BRAKE/Front SUSPENSION/STEERING SYSTEM



Mongoose/KXR 90/50

Apply the grease onto the rubber collar and then install the rubber collar.

Install the steering bracket and tighten the two bolts.

**Torque:** 1.8~2.5kgf-m

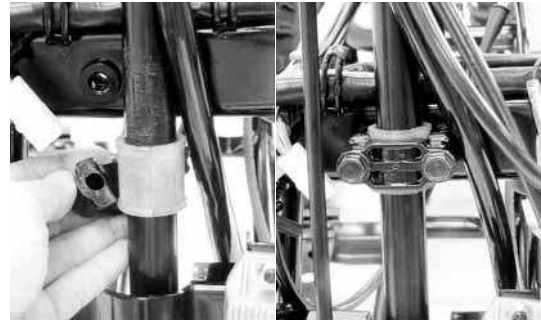

Install the tie rods and tighten the nuts.

**Torque:** 2.0~3.0kgf-m

Install the cotter pin and band ends of cotter pin.

\*

Always use a new cotter pin.



Apply the grease onto the end of the throttle cable and end of the brake cable.



# 12. FRONT WHEEL/Front BRAKE/Front SUSPENSION/STEERING SYSTEM **KYMCO** Mongoose/KXR 90/50

## TIE-ROD REMOVAL

Remove the cotter pin and nut at the steering knuckle.  
Remove the cotter pin and nut at the steering column.  
Remove the tie-rod.

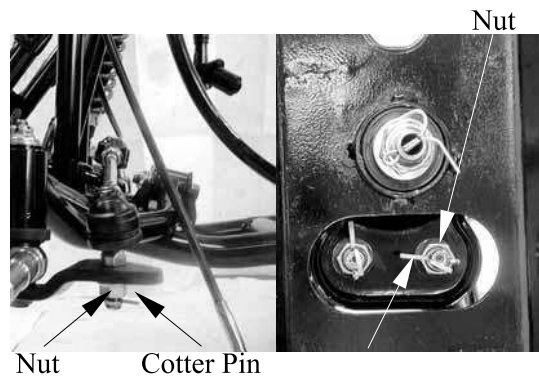

## INSPECTION

Inspect the tie-rod.  
Replace if bend or damage.

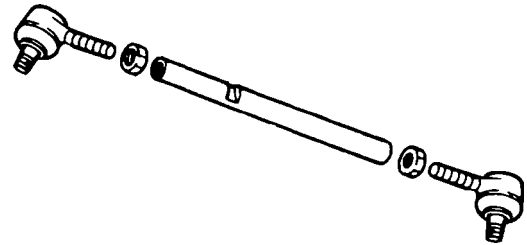

Check the tie-rod end movement.  
Replace it if the tie-rod end exists free play or turns roughly.  
Check the tapered surface of the tie-rod end.  
Replace it if pitting, wear or damage.

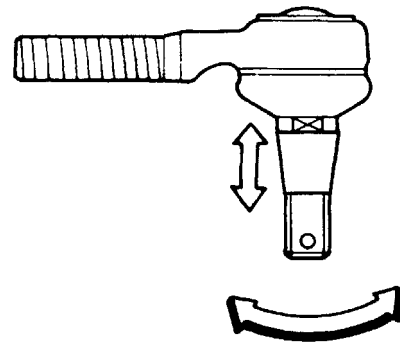

Adjust the tie-rod length.  
Adjustment steps:  
(The following procedures are done on both tie-rods, right and left.)  
Loosen the lock nuts.  
Adjust the tie-rod length by tuning both tie-rod ends.

**Tie rod length:** 254.5~255.5mm

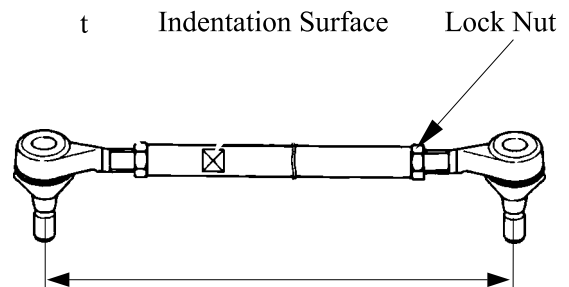

## 12. FRONT WHEEL/FRONT BRAKE/FRONT SUSPENSION/STEERING SYSTEM



Mongoose/KXR 90/50

Set the rod-end (steering column side) in an angle where the indentation surface of the tie-rod is parallel to the rod-end shaft, and then tighten the lock nut.

**Torque:** 2.0~3.0kgf-m

Set the other rod-end (knuckle arm side) in an angle as shown (right-hand tie-rod and left-hand tie-rod), and then tighten the lock nut.

Rod-end (tie rod) angle (A):  $15^{\circ} \pm 3^{\circ}$

**Torque:** 2.0~3.0kgf-m

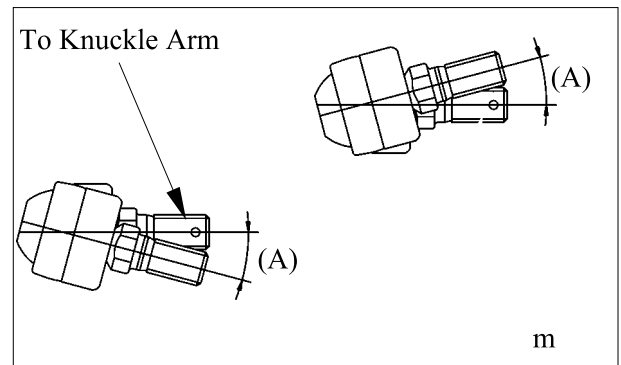

\* After making adjustment on both tie rods be sure to mark them R and L for identification.

\* The threads on both rod-end must be of the same length.

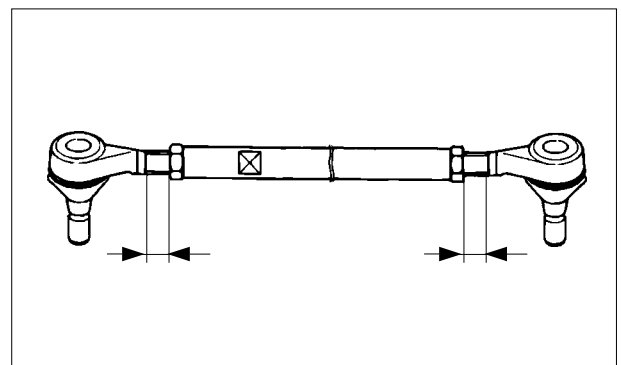

### INSTALLATION

Install the tie-rod and tighten the nuts.

**Torque:** 2.5~3.5kgf-m

\* Be sure that the rod-end on the indentation surface side is connected to the steering knuckle.

Install the cotter pins and band ends of cotter pin.

\* Always use a new cotter pin.

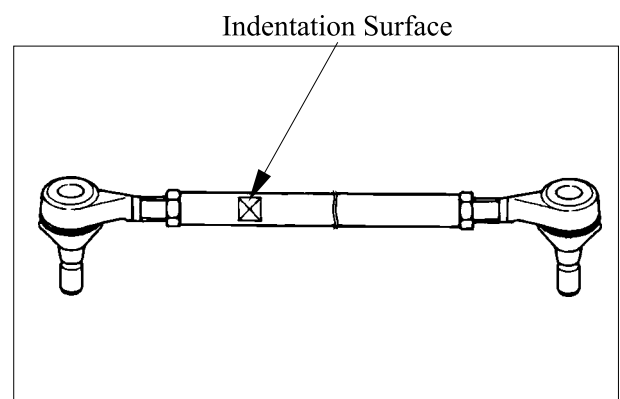

Refer to the "TOE-IN ADJUSTMENT" section in the CHAPTER 3 to adjust toe-in.

---

---

---

---

---

---

---

---

**REAR WHEEL/SWING ARM/  
HYDRAULIC BRAKE**

---

SERVICE INFORMATION-----	13- 2
REAR WHEEL-----	13- 4
REAR SWING ARM-----	13-10
HYDRAULIC BRAKE -----	13-15
BRAKE PAD/DISK -----	13-16
BRAKE MASTER CYLINDER -----	13-17
BRAKE CALIPER -----	13-20
DRUM BRAKE -----	13-22

# 13. REAR WHEEL/SWING ARM/ HYDRAULIC BRAKE

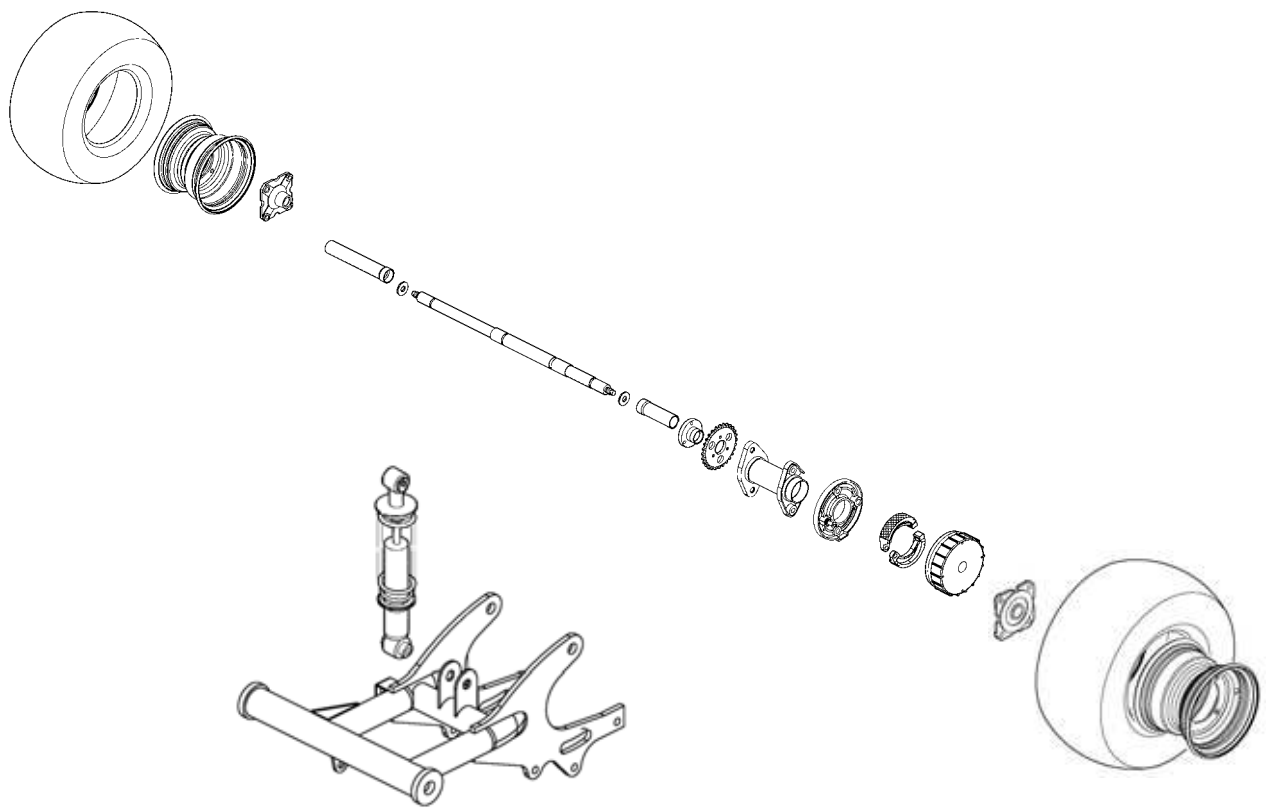

## SERVICE INFORMATION

### GENERAL INSTRUCTIONS

- During servicing, keep oil or grease off the brake drum and brake linings.
- During servicing, keep oil or grease off the brake disk and brake pads.
- Drain the brake fluid from the hydraulic brake system before disassembly.
- Contaminated brake disk or brake pads reduce stopping power. Clean the contaminated brake disk with high-performance brake degreaser and replace the brake pads.
- Do not use brake fluid for cleaning.
- Bleed air from the brake system if the brake system is removed or the brake is soft.
- Do not allow any foreign matters entering the brake reservoir when filling the brake reservoir with brake fluid.
- Brake fluid will damage painted, coated surfaces and plastic parts. When working with brake fluid, use shop towels to cover and protect painted, rubber and plastic parts. Wipe off any splash of brake fluid with a clean towel. Do not wipe the motorcycle with a towel contaminated by brake fluid.
- Make sure to use recommended brake fluid. Use of other unspecified brake fluids may cause brake failure.
- Inspect the brake operation before riding.

### SPECIFICATIONS

Item		Standard (mm)	Service Limit (mm)
Rear wheel	Rim run out	Radial	—
		Axial	—
	Rear brake drum I.D		130~130.2
Brake disk thickness (disk brake)		3.8~4.2	3.0
Brake disk runout (disk brake)		—	0.3
Rear brake lining thickness (drum brake)		4.5	2.0

### TORQUE VALUES

Rear wheel nut	4.0~5.0kgf-m
Rear shock absorber upper mount bolt	3.5~4.5kgf-m
Rear shock absorber lower mount bolt	3.5~4.5kgf-m
Rear swing arm axle	6.0~8.0kgf-m
Rear wheel hub nut	6.0~8.0kgf-m
Brake arm bolt	1.8~2.5kgf-m
Caliper holder bolt	2.9~3.5kgf-m
Brake fluid tube bolt	3.0~4.0kgf-m
Caliper bleed valve	0.4~0.7kgf-m
Master cylinder bolt	1.0~1.4kgf-m

## TROUBLESHOOTING

### Rear wheel wobbling

- Bent rim
- Faulty tire
- Axle not tightened properly

### Soft rear shock absorber

- Weak shock absorber spring
- Faulty damper

### Loose brake lever (Disk Brake)

- Air in hydraulic brake system
- Brake fluid level too low
- Hydraulic brake system leakage

### Hard braking (Disk Brake)

- Seized hydraulic brake system
- Seized piston

### Brake noise (Disk Brake)

- Contaminated brake pad surface
- Excessive brake disk run out
- Incorrectly installed caliper
- Brake disk or wheel not aligned

### Poor brake performance (Disk Brake)

- Air in brake system
- Deteriorated brake fluid
- Contaminated brake pads and brake disk
- Worn brake pads
- Worn brake master cylinder piston oil seal
- Clogged brake fluid line
- Deformed brake disk
- Unevenly worn brake caliper

### Poor brake performance (Drum Brake)

- Brake not adjusted properly
- Worn brake linings
- Worn brake shoes at cam contacting area
- Worn brake cam
- Worn brake drum

### Tight brake lever (Disk Brake)

- Seized piston
- Clogged hydraulic brake system
- Smooth or worn brake pad

### Poor brake performance (Disk Brake)

Contaminated brake pad surface

# 13. REAR WHEEL/SWING ARM/ HYDRAULIC BRAKE

## REAR WHEEL

### REAR WHEEL REMOVAL

Place the machine on a level place.  
Remove four nuts attaching the wheel.

\* Elevate the rear wheels by placing a suitable stand under the rear of frame.  
Support the machine securely so there is no danger of it falling over.

Remove wheel.



Nuts

### INSPECTION

Measure the wheel runout.

#### Service Limit:

Vertical: 2.0 mm

Lateral: 2.0mm

Replace wheel if out of specification.

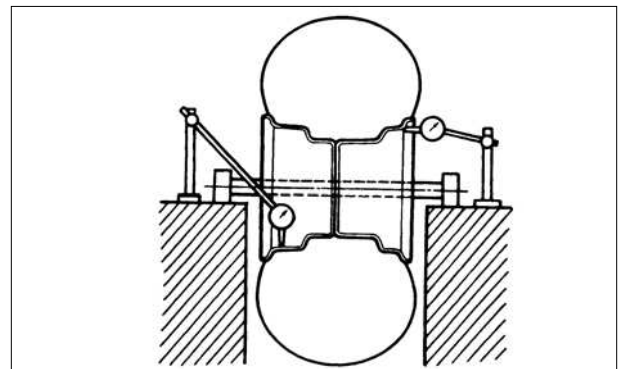

### INSTALLATION

Install the rear wheel and tighten the nuts (wheel).

**Torque: 4.0~5.0kgf-m**

# 13. REAR WHEEL/SWING ARM/ HYDRAULIC BRAKE

## REAR WHEEL HUB REMOVAL

Remove rear wheel nuts. (See page 13-4)  
Remove the wheel hub nut cover and cotter pin.  
Loosen nut attaching the wheel hub.

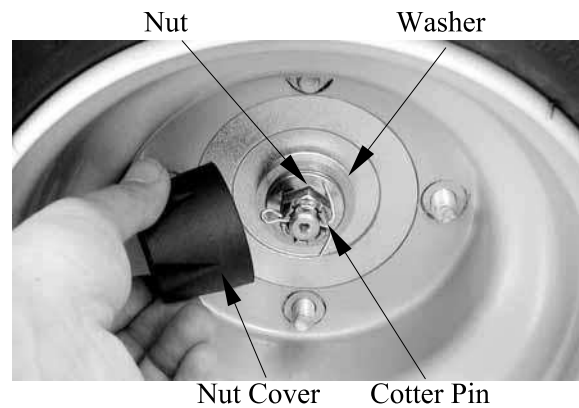

Remove rear wheel. (See page 13-4)  
Remove wheel hub nut, washer and wheel hub.

- \* Elevate the rear wheels by placing a suitable stand under the rear of frame. Support the machine securely so there is no danger of it falling over.

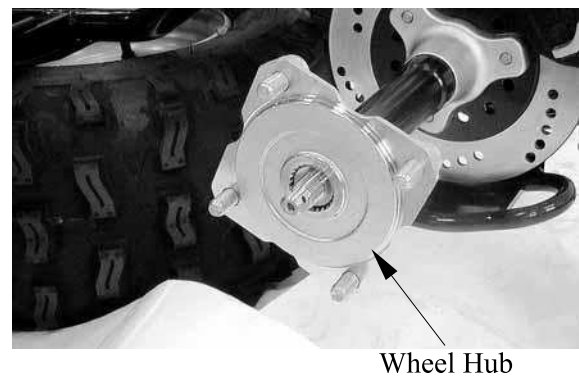

## INSPECTION

Replace it if the wheel hub is cracks or damage.

Replace it if splines of the wheel hub is wear or damage.

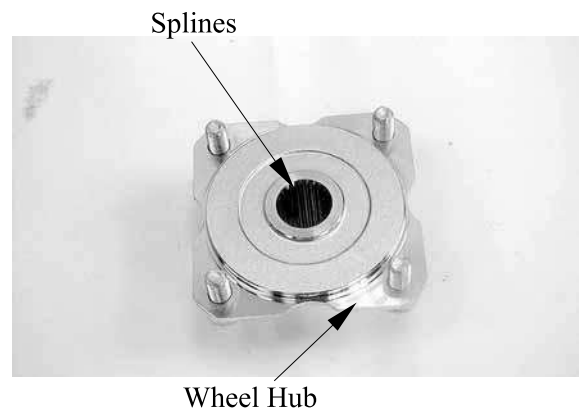

## INSTALLATION

- \* Apply grease onto the splines of the wheel hub.

Install wheel hub, washer and wheel hub nut.

**Torque:** 6.0~8.0kgf-m

Install the cotter pin and band ends of cotter pin.

- \* Do not loosen the axle nut after torque tightening. If the axle nut groove is not aligned with the cotter pin hole, align groove with the hole by tightening up on the axle nut.

- \* Always use a new cotter pin.

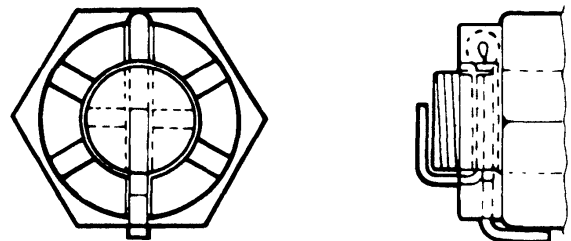



# 13. REAR WHEEL/SWING ARM/ HYDRAULIC BRAKE

## REAR AXLE REMOVAL

Remove the rear wheel hub of the both rear wheels. (See page 13-5).

Remove the collars on the rear axle right and left side.

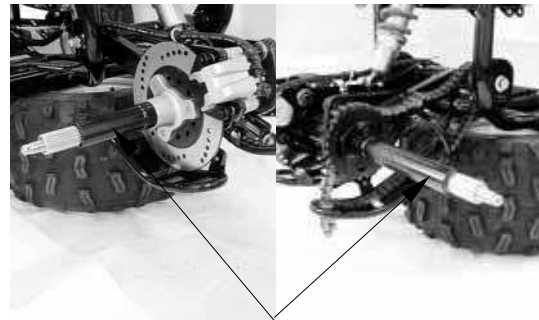

Collars

Relax the drive chain. (Refer to the “DRIVE CHAIN SLACK ADJUSTMENT” section in chapter 3.)

Remove driven sprocket.

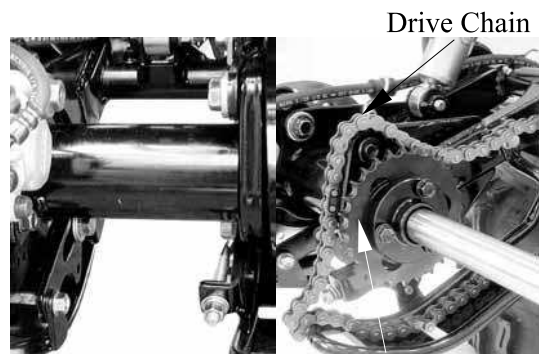

Drive Chain

Driven Sprocket

Remove the rear axle from right side.

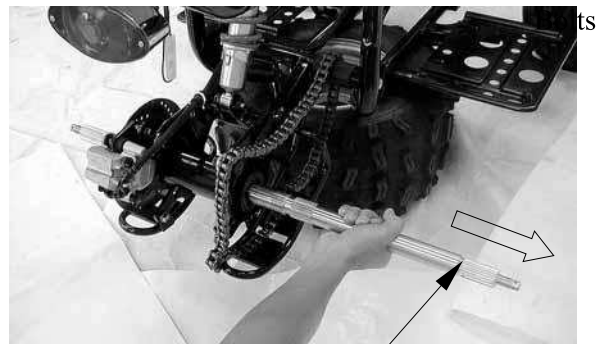

Rear Axle

Remove the two bolts and caliper and then remove brake disk.

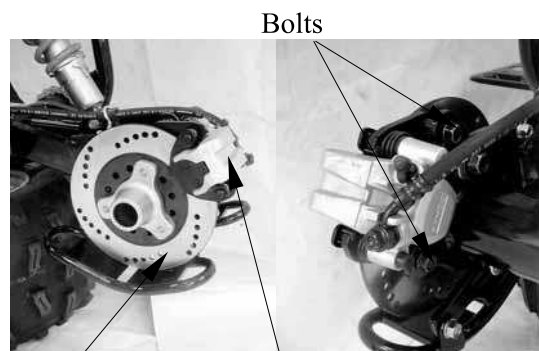

Bolts

Brake Disk

Caliper

# 13. REAR WHEEL/SWING ARM/ HYDRAULIC BRAKE

Remove the four bolts and rear axle hub.

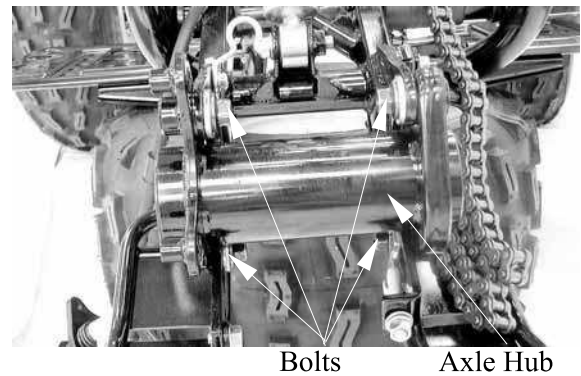

## INSPECTION

Replace it if the rear axle is scratched (excessively) or damaged.

Replace if splines and threads of the rear axle are worn or damaged.



Measure the rear axle run out.

**Service limit:** less than 1.5mm

Replace if it is out of specification.

\* Do not attempt to straighten a bent axle.



Replace it if the driven sprocket has cracks or damage.

Replace it if the splines of the driven sprocket are worn or damaged.



Splines

# 13. REAR WHEEL/SWING ARM/ HYDRAULIC BRAKE

Inspect the driven sprocket.  
Replace sprocket if more than 1/4 teeth wear or bent teeth.

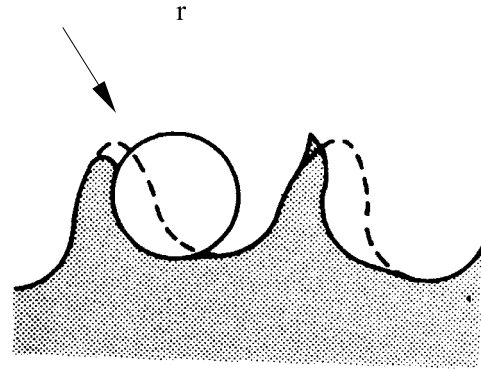

Replace it if the brake disk is cracks or damage.  
Replace it if splines of the brake disk is wear or damage.

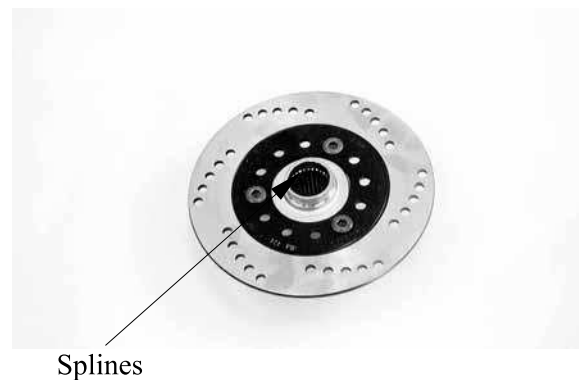

Inspect rear axle hub.  
Replace it if bearing allow play in the axle hub or the bearing turns roughly.  
Replace it if oil seal is wear or damage.  
Replace it if rear axle hub is cracks, bend or damage.  
Bearing and oil seal replacement steps:  
Clean the outside of the rear axle.  
Remove the oil seal by a flat-head screw driver.

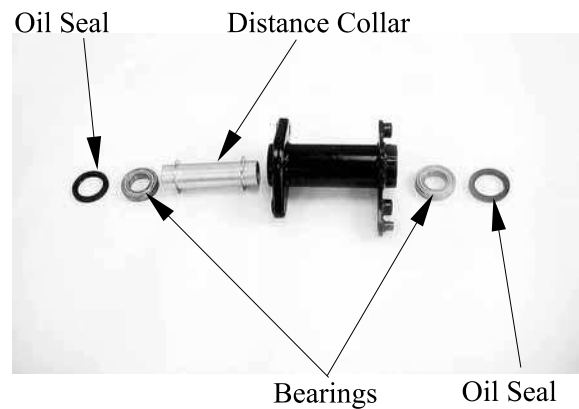

\* Place a wood block against the outer edge to protect this edge.

Remove the bearing by a general bearing puller.

Install the new bearings and oil seal by reversing the previous steps.

\* Do not strike the center race or balls of the bearing.  
Contact should be made only with the outer race.

# 13. REAR WHEEL/SWING ARM/ HYDRAULIC BRAKE

## INSTALLATION

Reverse the “REMOVAL” procedures.

Install the rear axle hub.

\*

Apply grease onto the oil seal lips,  
bearings and bushes.

\*

At this time, the rear axle hub should not  
be tightened completely.  
Final tightening is done after the chain  
slack adjustment.

Install the rear axle.

Install brake disk, driven sprocket and  
collars.

Install wheel hub (see page 13-5) and rear  
wheel (see page 13-4).

Adjust drive chain slack. (Refer to the  
“DRIVE CHAIN SLACK ADJUSTMENT”  
section in chapter 3.)

**Approximately:** 10~20 mm

# 13. REAR WHEEL/SWING ARM/ HYDRAULIC BRAKE

## REAR SWING ARM

### REMOVAL

Place the machine on a level place.

Elevate the rear wheels by placing a suitable stand under the rear of frame.

- \* Support the machine securely so there is no danger of it falling over.

Remove the rear wheels, rear hubs, rear axle and axle hub. (Refer to the “REAR WHEEL” section in chapter 13.)

Remove the lower bolt attaching the rear shock absorber.

- \* When removing the lower bolt, hold the swing arm so that it does not drop downwards when the bolt is removed.

Remove the upper bolt and then remove the shock absorber.

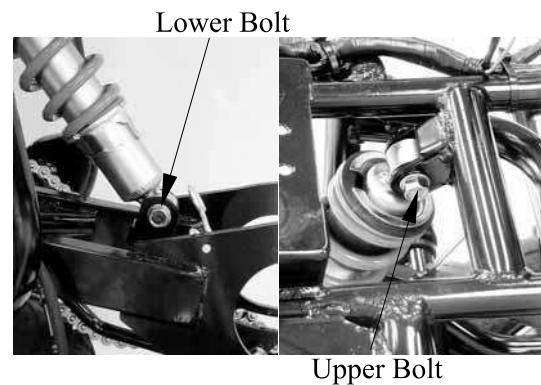

### INSPECTION

Check the tightening torque of the pivot shaft (swing arm) securing nut.

**Torque:** 6.0~8.0kgf-m



# 13. REAR WHEEL/SWING ARM/ HYDRAULIC BRAKE

Check the swing arm side play by moving it from side to side.

If side play noticeable, check the inner collar, bushing and thrust cover.

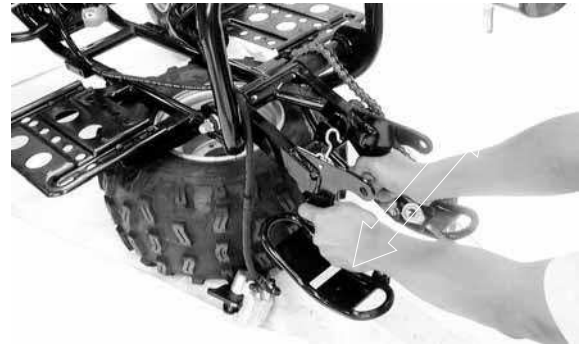

Check the swing arm vertical movement by moving it up and down.

If vertical movement is tight, binding or rough, to check the inner collar, bushing and thrust cover.



## INSPECTION

Inspect the shock absorber rod.

Replace the shock absorber assembly if bends or damage.

Inspect the shock absorber.

Replace the shock absorber assembly if oil leaks

Inspect the spring.

Replace the shock absorber assembly if fatigue.

Move the spring up and down.

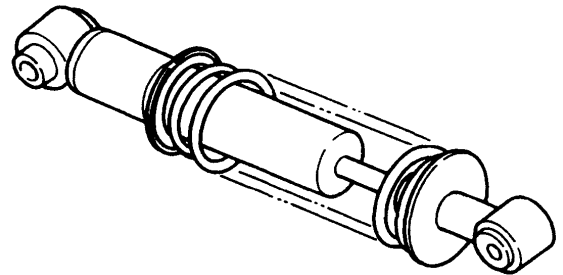

# 13. REAR WHEEL/SWING ARM/ HYDRAULIC BRAKE

## REAR SWING ARM REMOVAL

Remove the nut and pivot shaft, then remove swing arm.

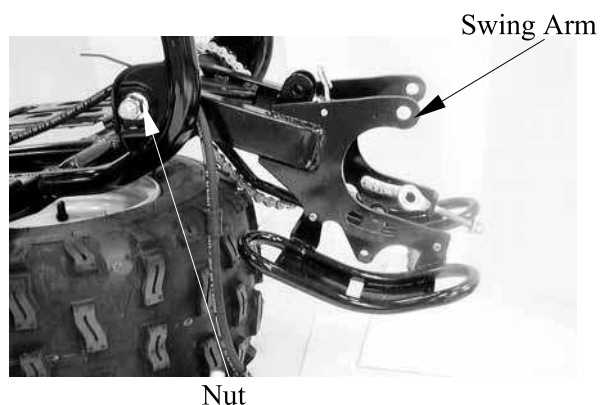

Remove the three bolts and chain guard.  
Remove the drive chain.

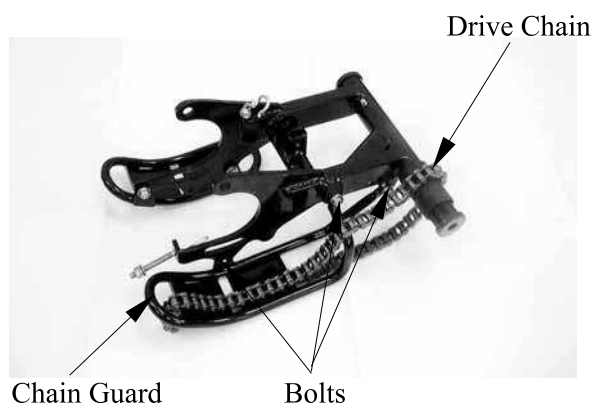

Remove thrust covers and collar.

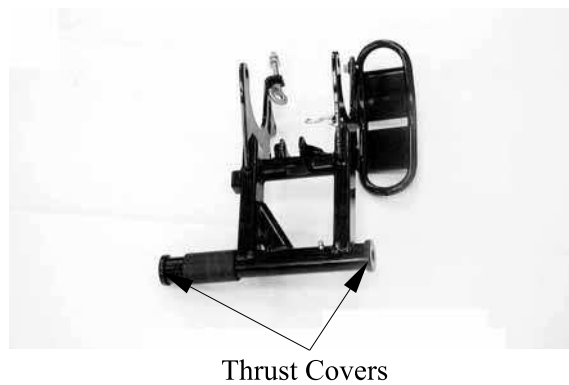

# 13. REAR WHEEL/SWING ARM/ HYDRAULIC BRAKE

### INSPECTION

Roll the axle on a flat surface to inspect the pivot shaft.

Replace it if bends.

\*

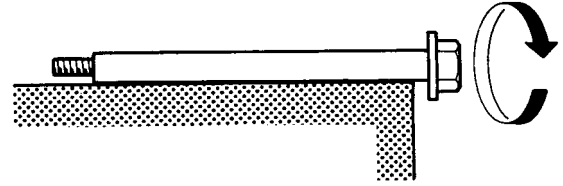

Inspect the swing arm.

Replace it if crack, bend or damage.

Inspect the thrust cover, chain guide, collar and bush.

Replace them if wear or damage.

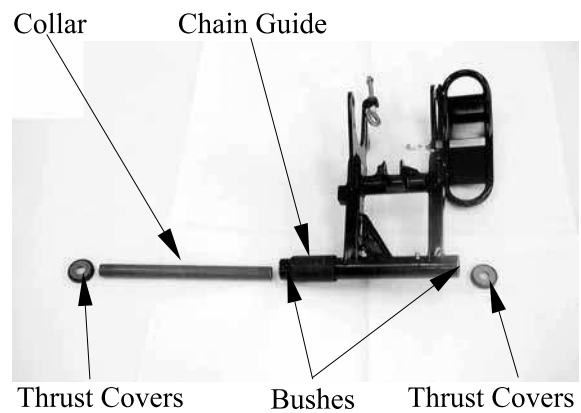

Inspect the drive chain stiffness.

Clean and lubricate or replace it if stiff.

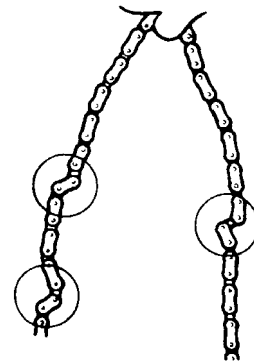

### CLEAN

Place it in kerosene, and brush off as much dirt as possible. Then remove the chain from the kerosene and dry the chain.

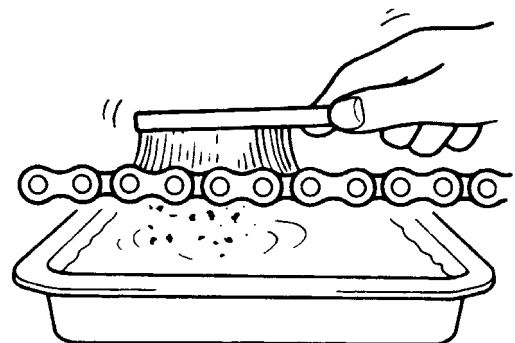



## 13. REAR WHEEL/SWING ARM/ HYDRAULIC BRAKE

 **KYMCO**  
Mongoose/KXR 90/50

\*

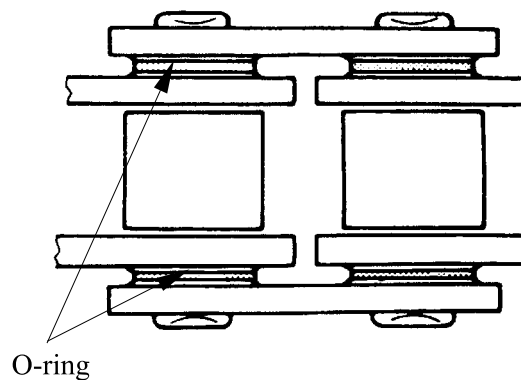

### INSTALLATION

Reverse the “REMOVAL” procedure.

Apply grease onto the collar, bush, pivot shaft and thrust cover.

Install the swing arm and tightening the nut.

**Torque:** 6.0~8.0kgf-m

Install the shock absorber and tightening the bolts.

**Torque:** 3.5~4.5kgf-m

# 13. REAR WHEEL/SWING ARM/ HYDRAULIC BRAKE

## HYDRAULIC BRAKE

### BRAKE FLUID CHANGE

Place the machine on a level place and set the handlebar upright.  
Remove the two screws attaching the brake fluid reservoir cap.

Use shop towels to cover plastic parts and coated surfaces to avoid damage caused by splash of brake fluid.



Screw

Connect a transparent hose to the brake caliper bleed valve and then loosen the bleed valve nut.  
Use a syringe to draw the brake fluid out through the hose.

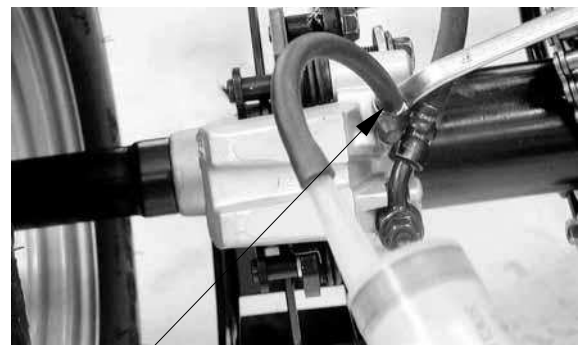

Bleed Valve

### BRAKE FLUID REFILLING

Connect a transparent hose and syringe to the brake caliper bleed valve and then loosen the bleed valve nut.  
Fill the brake reservoir with brake fluid and use the syringe to draw brake fluid into it until there is no air bubbles in the hose.  
Then, tighten the bleed valve nut.

**Torque:** 0.4~0.7kg-m

- When drawing brake fluid with the syringe, the brake fluid level should be kept over 1/2 of the brake reservoir height.
- Use only the recommended brake fluid.

Brake Reservoir

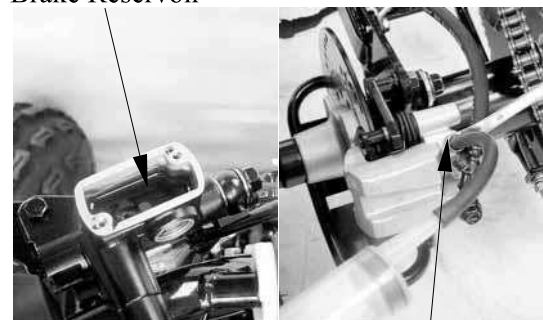

Bleed Valve

**Recommended Brake Fluid:** DOT-4

# 13. REAR WHEEL/SWING ARM/ HYDRAULIC BRAKE

## BRAKE SYSTEM BLEEDING

Connect a transparent hose to the bleed valve and fully apply the brake lever after continuously pull it several times. Then, loosen the bleed valve nut to bleed air from the brake system. Repeat these steps until the brake system is free of air.

When bleeding air from the brake system, the brake fluid level should be kept over 1/2 of the brake reservoir height.

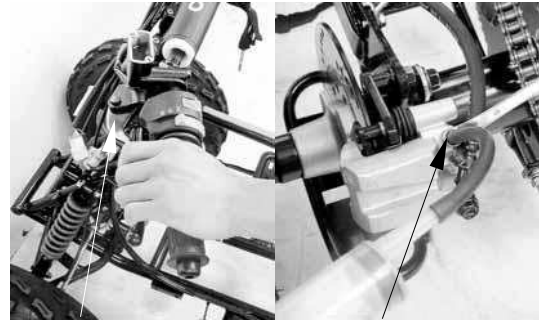

Brake Lever

Bleed Valve

## BRAKE PAD/DISK

### BRAKE PAD REPLACEMENT

Remove the two bolts attaching the brake caliper holder.

The brake pads can be replaced without removing the brake fluid tube.

Remove the brake caliper.



Bolts

Push the brake caliper holder and then remove brake pad.

Brake Caliper Holder

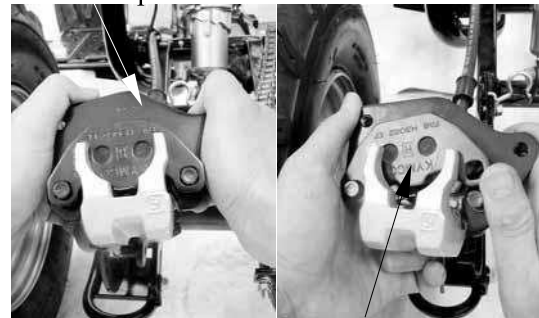

Brake Pad

Remove the other brake pad.

### ASSEMBLY

Assemble the brake pads in the reverse order of removal.

Make sure the pad spring has fitted.



Brake Pad

Pad Spring

# 13. REAR WHEEL/SWING ARM/ HYDRAULIC BRAKE

## BRAKE DISK

Measure the brake disk thickness.

**Service Limit:** 3.0mm

Measure the brake disk run out.

**Service Limit:** 0.3mm



## BRAKE MASTER CYLINDER

### REMOVAL

Drain the brake fluid from the hydraulic brake system.

Do not splash brake fluid onto any rubber, plastic and coated parts. When working with brake fluid, use shop towels to cover these parts.

Remove the two master cylinder holder bolts and remove the master cylinder.

When removing the brake fluid tube bolt, be sure to place towels under the tube and plug the tube end to avoid brake fluid leakage and contamination.

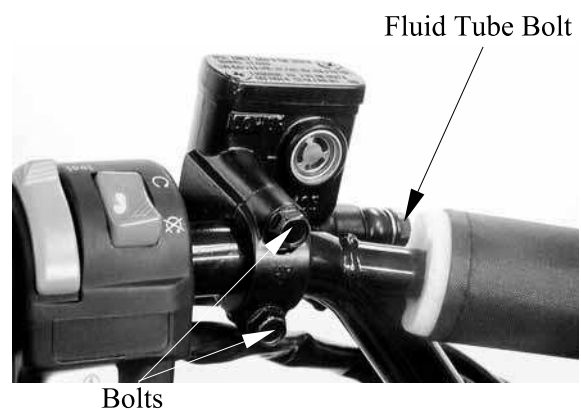

# 13. REAR WHEEL/SWING ARM/ HYDRAULIC BRAKE

## DISASSEMBLY

Remove the piston rubber cover and snap ring from the brake master cylinder.



Snap Ring Pliers

Remove the washer, main piston and spring from the brake master cylinder.  
Clean the inside of the master cylinder and brake reservoir with brake fluid.

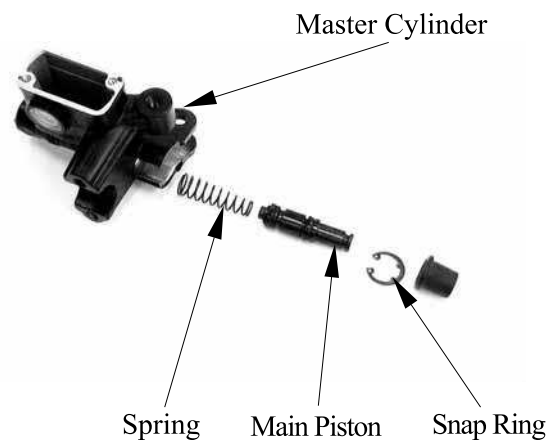

## INSPECTION

Check the cylinder inside wall, and spring for scratch, corrosion or other abnormal condition.

If any abnormal condition is found, replace the inner parts or master cylinder.



# 13. REAR WHEEL/SWING ARM/ HYDRAULIC BRAKE

## ASSEMBLY

Before assembly, apply brake fluid to all removed parts.

- \* During assembly, the main piston and spring must be installed as a unit without exchange.
- When assembling the piston, soak the cups in brake fluid for a while.
- Install the cups with the cup lips facing the correct direction.



Install the main piston and snap ring.  
Install the rubber cover.  
Install the brake lever.  
Install the brake fluid tube with the bolt and two sealing washers.  
Fill the brake reservoir with recommended brake fluid to the upper level.  
Bleed air from the hydraulic brake system.  
(See page 13-15.)



Fluid Tube Bolt      Sealing Washer

Place the brake master cylinder on the handlebar and install the master cylinder holder with the "UP" mark facing up, aligning the tab on the holder with the hole in the handlebar.  
First tighten the upper bolt and then tighten the lower bolt.

**Torque:** 1.0~1.4kg-m



"UP" Mark

# 13. REAR WHEEL/SWING ARM/ HYDRAULIC BRAKE

## BRAKE CALIPER

### DISASSEMBLY

Remove the brake caliper, brake pads and pad spring. (See page 13-16)  
Place a clean container under the brake caliper and disconnect the brake fluid tube from the brake caliper.

Be careful not to splash brake fluid on any coated surfaces.



### DISASSEMBLY

Remove the brake caliper holder from the brake caliper.

Brake Caliper Holder

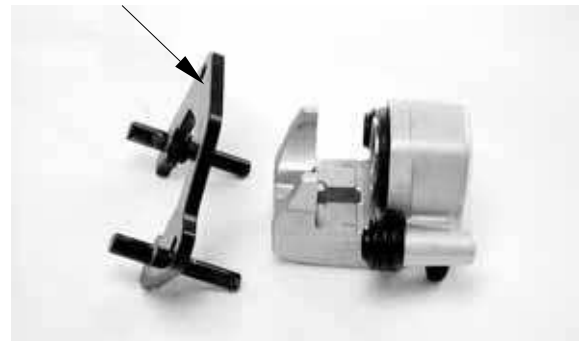

Remove the pistons from the brake caliper. Use compressed air to press out the pistons through the brake fluid inlet opening and place a shop towel under the caliper to avoid contamination caused by the removed pistons.



Push the piston oil seals inward to remove them. Clean each oil seal groove with brake fluid.

Piston Oil Seals



Be careful not to damage the piston surface.

# 13. REAR WHEEL/SWING ARM/ HYDRAULIC BRAKE

## INSPECTION

Inspect the caliper cylinder wall and piston surface for scratch, corrosion or other damages.  
If any abnormal condition is noted, replace the caliper.



## ASSEMBLY

Clean all removed parts.  
Apply silicon grease to the pistons and oil seals. Lubricate the brake caliper cylinder inside wall with brake fluid.  
Install the oil seals and then install the brake caliper pistons with the grooved side facing out.

Install the piston with its outer end protruding 3~5mm beyond the brake caliper.



Wipe off excessive brake fluid with a clean shop towel. Apply silicon grease to the brake caliper holder pin and caliper inside.  
Install the brake caliper holder.



# 13. REAR WHEEL/SWING ARM/ HYDRAULIC BRAKE

## INSTALLATION

Connect the brake fluid tube to the brake caliper, aligning the fluid tube with groove in the caliper and tighten the fluid tube bolt.

**Torque:** 3.0~4.0kg-m

Add the recommended brake fluid into the brake reservoir and bleed air from the brake system. (Refer to 13-15.)

Aligning The Fluid Tube With Groove

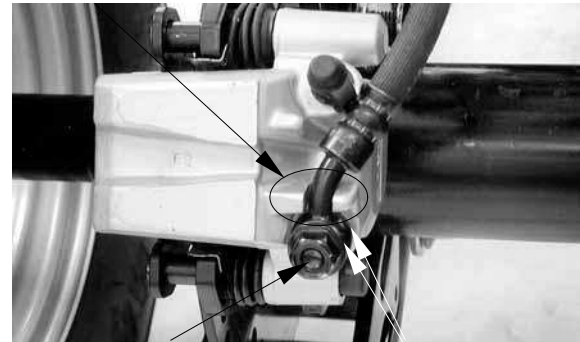

Fluid Tube Bolt

Washers

Install the brake caliper onto rear axle hub and tighten the bolts.

**Torque:** 2.9~3.5kg-m

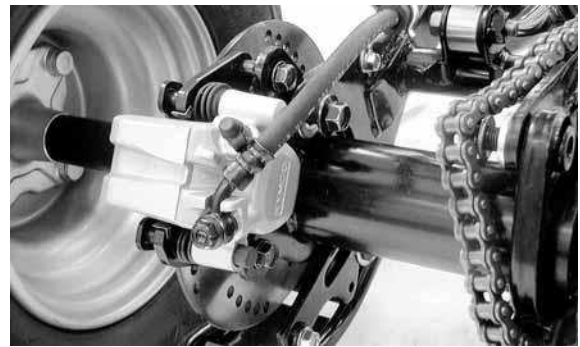

## DRUM BRAKE

### REMOVAL

Remove wheel hub and axle hub. (See page 13-5)

Remove brake drum.

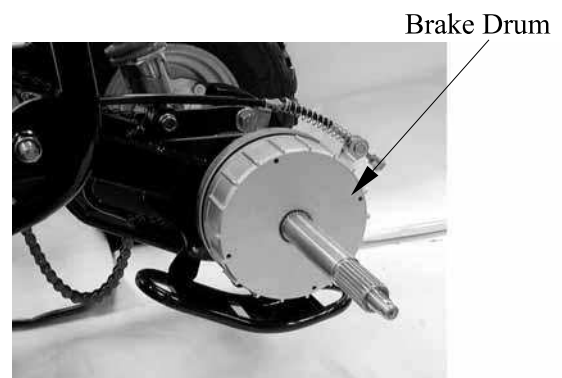

Brake Drum

Remove brake shoes.

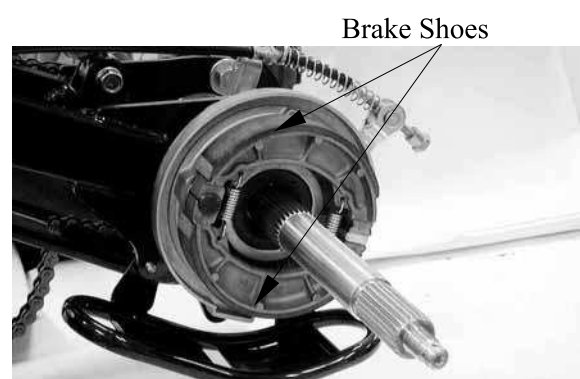

Brake Shoes

# 13. REAR WHEEL/SWING ARM/ HYDRAULIC BRAKE

## INSPECTION

Inspect the inner surface of the brake drum is scratches, polish brake drum lightly and evenly with emery cloth.

Measure the inside diameter of the brake drum.

**Service limit:** 131mm

Replace it if it is out of specification.

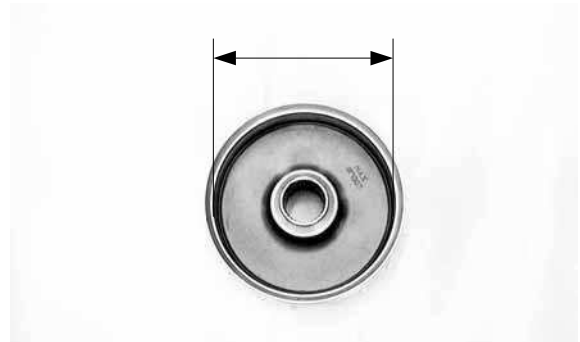

Measure the front brake lining thickness (A).

**Service limit:** 2.0mm replace it if below

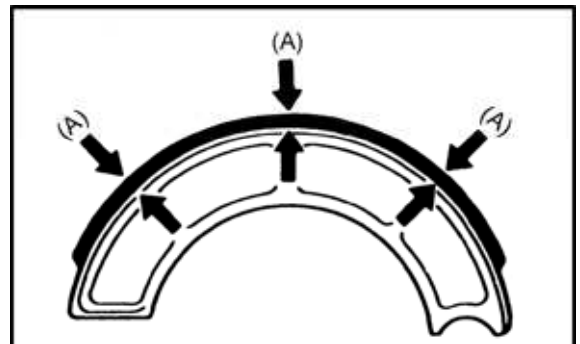

## INSTALLATION

Reverse the “REMOVE” procedures.

---

**BATTER/CHARGING SYSTEM/  
A.C. GENERATOR**

---

SERVICE INFORMATION-----	14- 2
BATTERY REMOVAL -----	14- 4
CHARGING SYSTEM -----	14- 6
REGULATOR/RECTIFIER-----	14- 7
A.C. GENERATOR CHARGING COIL -----	14- 8
A.C. GENERATOR LIGHTING COIL-----	14- 8
RESISTOR INSPECTION -----	14- 8
A.C. GENERATOR -----	14- 8

# 14. BATTERY/CHARGING SYSTEM/ A.C. GENERATOR

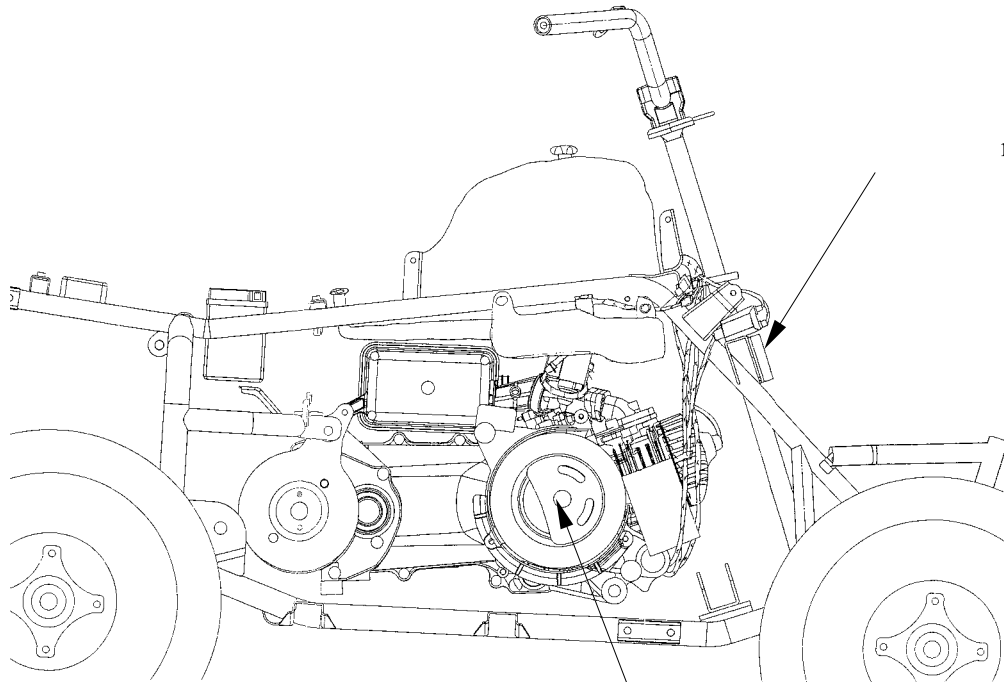

A.C. Generator

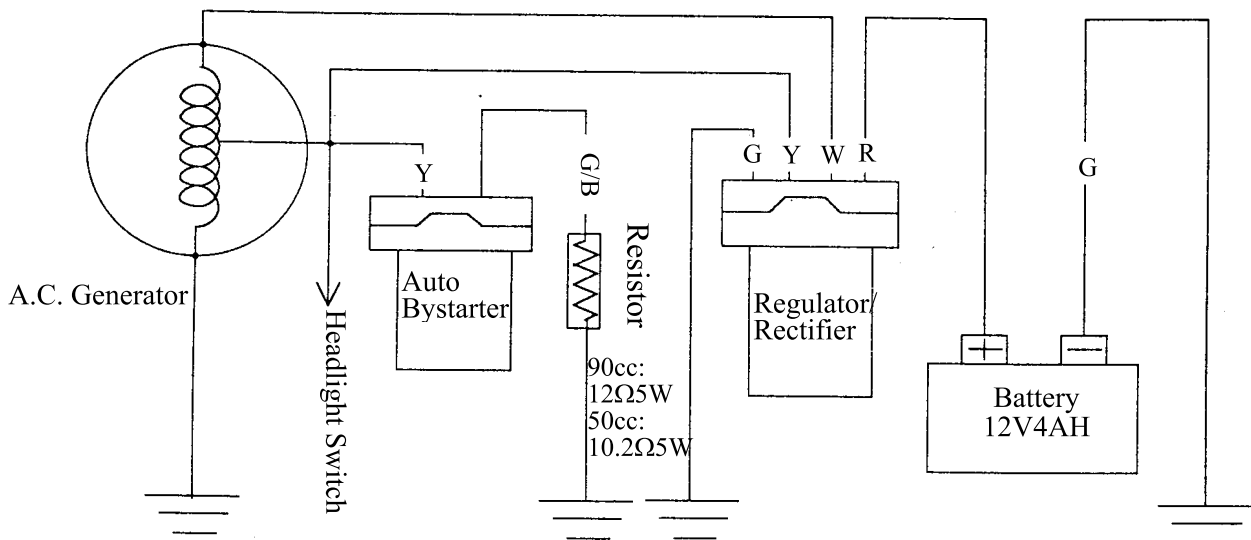

## SERVICE INFORMATION

### GENERAL INSTRUCTIONS

The battery electrolyte (sulfuric acid) is poisonous and may seriously damage the skin and eyes. Avoid contact with skin, eyes, or clothing. In case of contact, flush with water and get prompt medical attention

- The battery can be charged and discharged repeatedly. If a discharged battery is not used for a long time, its service life will be shortened. Generally, the capacity of a battery will decrease after it is used for 2~3 years. A capacity-decreased battery will resume its voltage after it is recharged but its voltage decreases suddenly and then increases when a load is added.
- When a battery is overcharged, some symptoms can be found. If there is a short circuit inside the battery, no voltage is produced on the battery terminals. If the rectifier won't operate, the voltage will become too high and shorten the battery service life.
- If a battery is not used for a long time, it will discharge by itself and should be recharged every 3 months.
- A new battery filled with electrolyte will generate voltage within a certain time and it should be recharged when the capacity is insufficient. Recharging a new battery will prolong its service life.
- Inspect the charging system according to the sequence specified in the Troubleshooting.
- Do not disconnect and soon reconnect the power of any electrical equipment because the electronic parts in the regulator/rectifier will be damaged. Turn off the ignition switch before operation.
- It is not necessary to check the MF battery electrolyte or fill with distilled water.
- Check the load of the whole charging system.
- Do not quick charge the battery. Quick charging should only be done in an emergency.
- Remove the battery from the motorcycle for charging.
- When replacing the battery, do not use a traditional battery.
- When charging, check the voltage with a voltmeter.

### SPECIFICATIONS

Item		Standard	
ATV Name & Type		Mongoose/KXR 90	Mongoose/KXR 50
Battery	Capacity/Model	12V4AH	
	Voltage (20°C)	Fully charged	13.1V
		Undercharged	12.3V
	Charging current	STD: 0.4A Quick: 4.0A	
Charging time	STD: 5~10hr Quick: 30min		
A.C. Generator	Capacity	150W	
Regulator/Rectifier	Charging	14.5±0.5V	

## TESTING INSTRUMENTS

Electric tester: YF-3051

## TROUBLESHOOTING

### No power

- Dead battery
- Disconnected battery cable
- Fuse burned out
- Faulty ignition switch

### Low power

- Weak battery
- Loose battery connection
- Charging system failure
- Faulty regulator/rectifier

### Intermittent power

- Loose battery cable connection
- Loose charging system connection
- Loose connection or short circuit in lighting system

### Charging system failure

- Loose, broken or shorted wire or connector
- Faulty regulator/rectifier
- Faulty A.C. generator

# 14. BATTERY/CHARGING SYSTEM/ A.C. GENERATOR

## BATTERY REMOVAL

Remove seat. (See page 2-3)  
Remove the battery cover, by removing the mount bolts. (Make sure the ignition switch is OFF)  
Remove the battery by removing the bolts.

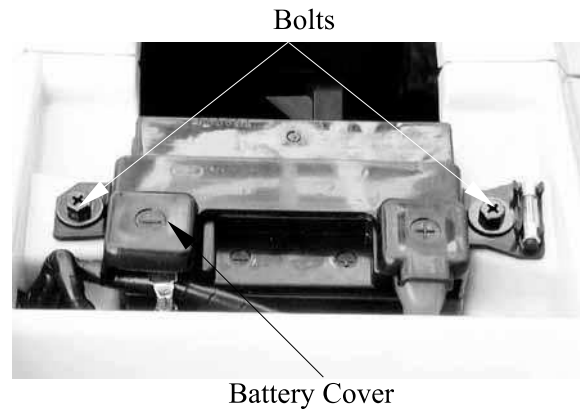

First disconnect the battery negative (-) cable and then the positive (+) cable.

 When disconnecting the battery positive (+) cable, do not touch the frame with tool; otherwise it will cause short circuit and sparks to fire the fuel.

The installation sequence is the reverse of removal.

 First connect the positive (+) cable and then negative (-) cable to avoid short circuit.

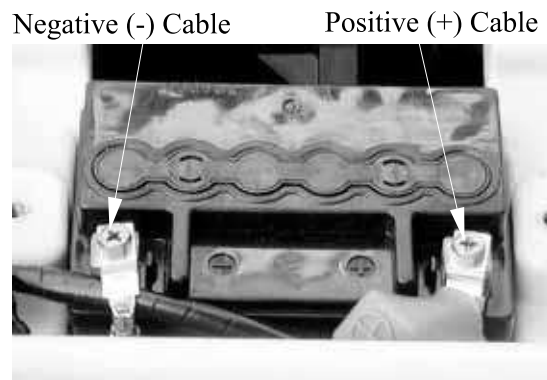

## BATTERY VOLTAGE (OPEN CIRCUIT VOLTAGE) INSPECTION

Remove the seat. (See page 2-3)  
Disconnect the battery cables.  
Measure the voltage between the battery terminals.

**Fully charged** : 13.1V  
**Undercharged** : 12.3V max

\* Battery charging inspection must be performed with a voltmeter.

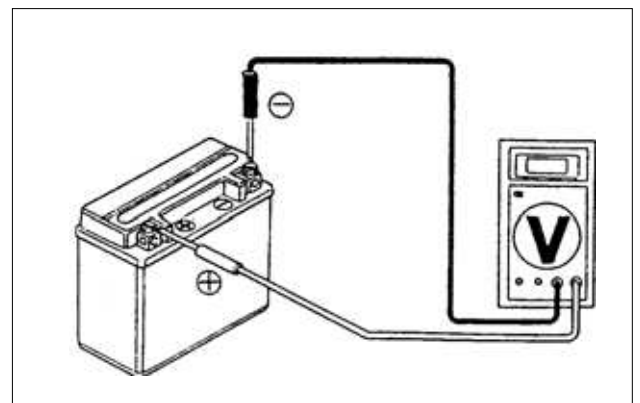

# 14. BATTERY/CHARGING SYSTEM/ A.C. GENERATOR

## CHARGING

Connect the charger positive (+) cable to the battery positive (+) terminal.  
Connect the charger negative (-) cable to the battery negative (-) terminal.



- Keep flames and sparks away from a charging battery.
- Turn power ON/OFF at the charger, not at the battery terminals to prevent sparks near the battery to avoid explosion.
- Charge the battery according to the



- \* Quick charging should only be done in an emergency.
- Measure the voltage 30 minutes after the battery is charged.

Charging current: Standard : 0.4A  
Quick : 4.0A  
Charging time : Standard : 5~10 hours  
Quick : 30 minutes  
After charging: Open circuit voltage: 12.8V min.

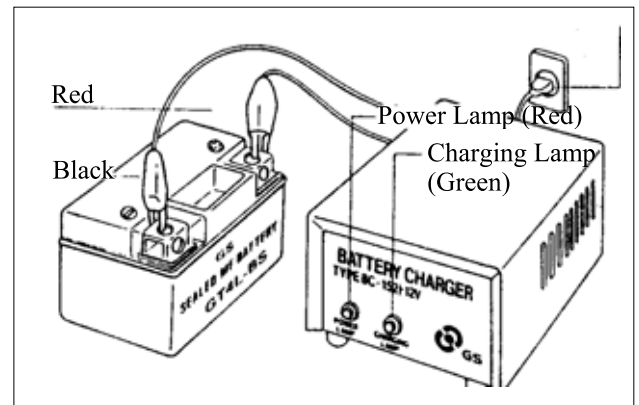



## CHARGING SYSTEM

### SHORT CIRCUIT TEST

Disconnect the ground wire from the battery and connect an ammeter across the battery negative (-) terminal and the ground wire. Turn the ignition switch OFF and check for short circuit.

\* Connect the electric tester positive (+) terminal to ground wire and the tester negative (-) terminal to the battery negative (-) terminal.

If any abnormality is found, check the ignition switch and wire harness for short circuit.

### CURRENT TEST

This inspection must be performed with an electric tester when the battery is fully charged.

Warm up the engine for inspection.

Connect the electric tester across the battery terminals. Disconnect the red wire from the fuse terminal and connect an ammeter between the red wire lead and the fuse terminal as shown.

Attach a tachometer to the engine.

Start the engine and gradually increase the engine speed to measure the limit voltage and current.

**Limit Voltage/Current:** 13.5~15.5V/0.5A  
max. (5000rpm  
max.)

If the limit voltage is not within the specified range, check the regulator/rectifier.



# 14. BATTERY/CHARGING SYSTEM/ A.C. GENERATOR

## REGULATOR/RECTIFIER

### MAIN HARNESS CIRCUIT INSPECTION

Remove the front covers. (⇒2-2)  
Remove the regulator/rectifier 4P coupler and check for continuity between the wire harness terminals according to the following :

Item (Wire Color)	Judgment
Between battery (red) and engine ground	Battery has voltage
Between ground (green) and engine ground	Continuity exists
Between lighting wire (yellow) and engine ground (Remove the resistor coupler and auto bystarter coupler and turn the lighting switch OFF for inspection)	A.C. generator stator has resistance
Between charging coil (white) and engine ground	A.C. generator stator has resistance



### REGULATOR/RECTIFIER INSPECTION

If the main harness terminals are normal, check the regulator/rectifier coupler for loose connection and measure the resistances between the regulator/rectifier terminals.

- Do not touch the tester probes with your finger because human body has resistance.
- Use the following specified testers for accurate testing. Use of an improper tester in an improper range may give false readings.  
Testing instrument  
YF-3501
- If the dry battery in the tester is weak, the readings will be incorrect. In this case, check the dry battery.

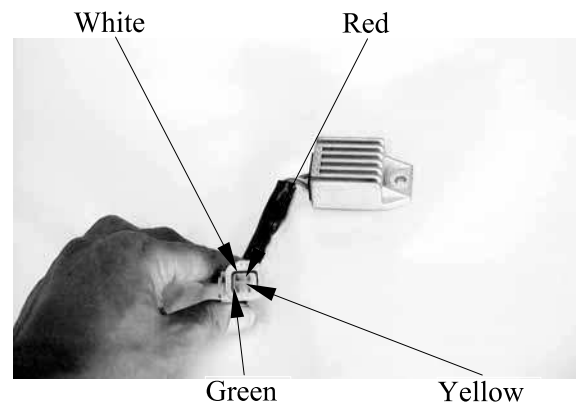

Probe⊕ Probe(-)	White	Yellow	Red	Green
White		∞	∞	∞
Yellow	∞		∞	10.75M
Red	6.62M	∞		∞
Green	∞	11.17M	∞	

Replace the regulator/rectifier if the readings are not within the specifications in the table.

## A.C. GENERATOR CHARGING COIL

The inspection of A.C. generator charging coil can be made with the engine installed.

### INSPECTION

Disconnect the A.C. generator 2P connector.

Measure the resistance between the A.C. generator white wire and engine ground with an electric tester (YF-3501 tester).

**Standard:** 2.2Ω(at 20°C)

Replace the A.C. generator charging coil if the reading is not within the specifications.

Charging Coil Wire

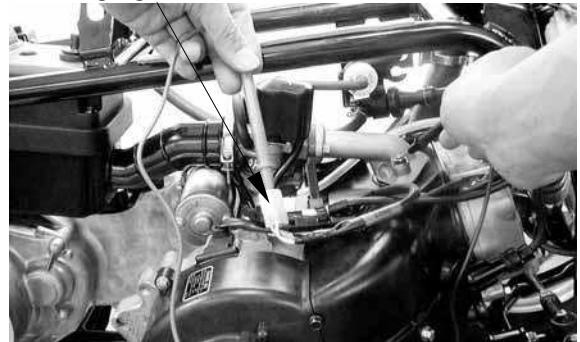

## A.C. GENERATOR LIGHTING COIL

The inspection of A.C. generator lighting coil can be made with the engine installed.

### INSPECTION

Disconnect the A.C. generator 2P connector.

Measure the resistance between the A.C. generator yellow wire and engine ground with an electric tester (YF-3501 tester).

**Standard:** 3.1Ω (20°C)

Replace the A.C. generator lighting coil if the reading is not within the specifications.

Lighting Coil Wire



## RESISTOR INSPECTION

Remove the front covers. (⇒2-2)

Measure the resistance between the resistor lead and engine ground.

### Resistances:

Mongoose/KXR 90: 5W12Ω  
30W7.5Ω

Mongoose/KXR 50: 5W10.2Ω  
30W5.9Ω

Resistor



## A.C. GENERATOR REMOVAL

Remove the four bolts attaching the cooling fan cover.

Remove the fan cover.

Fan Cover

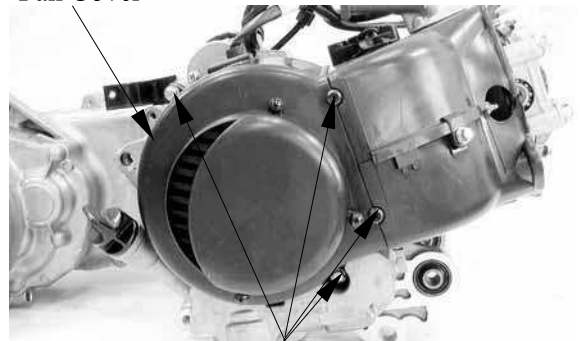

Bolts

# 14. BATTERY/CHARGING SYSTEM/ A.C. GENERATOR

Remove the cooling fan by removing the four cooling fan attaching bolts.

Cooling Fan

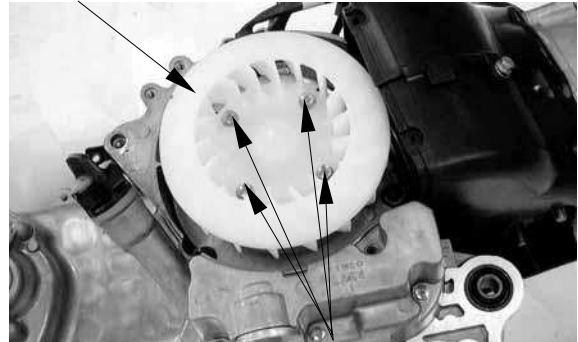

Bolts

Hold the flywheel with an universal holder.  
Remove the flywheel nut.

**Special**

Universal Holder                    E017



Universal Holder

Remove the A.C. generator flywheel using  
the flywheel puller.

**Special**

Flywheel Puller                    E001



Flywheel Puller

Remove the pulser coil bolts.  
Remove the A.C. generator wire rubber  
sleeve and pulser coil from the right  
crankcase.  
Remove the two bolts and A.C. generator  
stator.

Bolts

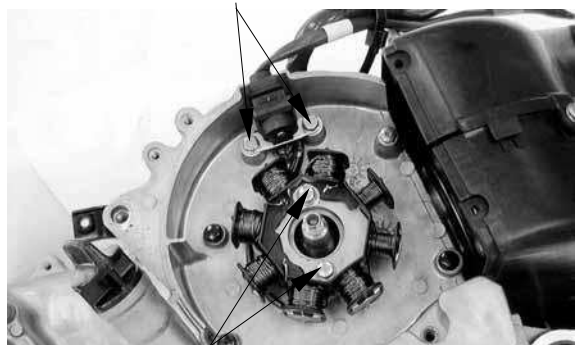

Bolts

## A.C. GENERATOR INSTALLATION

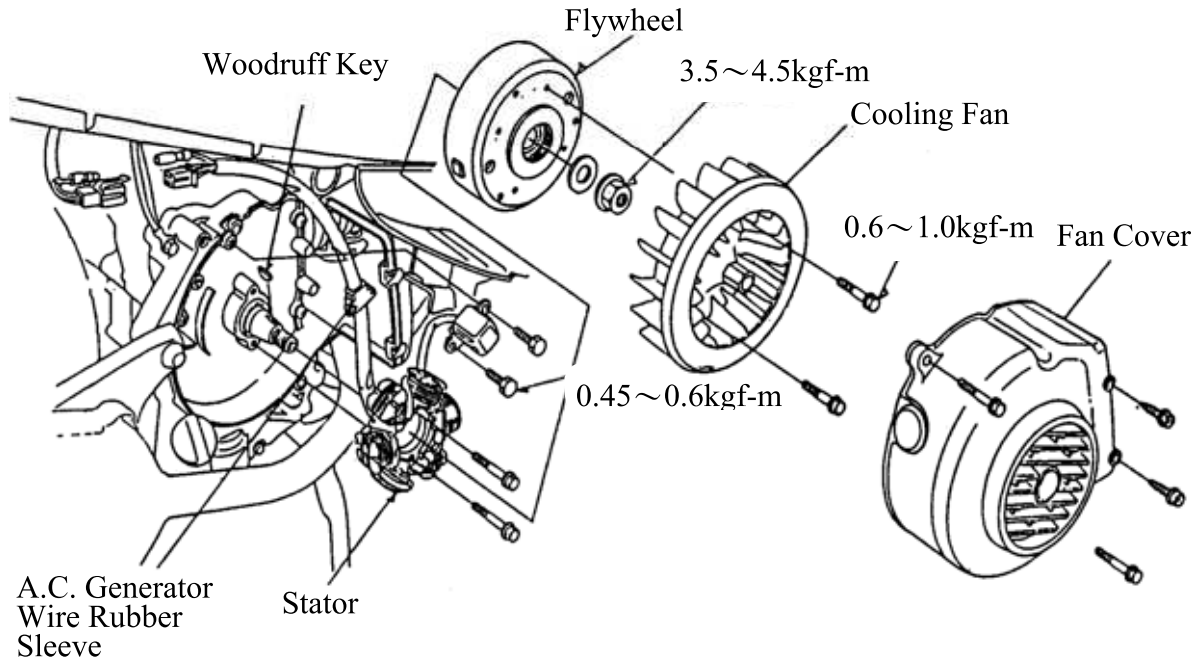

Reverse the A.C. GENERATOR  
REMOVE” procedures.

Install the A.C. generator stator and pulser  
coil onto the right crankcase.

Install the A.C. generator wire rubber  
sleeve.

Tighten the stator and pulser coil bolts.

**Torques: Pulser Coil :** 0.45~0.6kgf-m

**Stator:** 0.8~1.2kgf-m

Connect the A.C. generator wire connector.

Clean the taper hole in the flywheel off any  
burrs and dirt.

Install the woodruff key in the crankshaft  
keyway.

Install the flywheel onto the crankshaft with  
the flywheel hole aligned with the  
crankshaft woodruff key.

The inside of the flywheel is magnetic.  
Make sure that there is no bolt or nut  
before installation.



Woodruff Key

## 14. BATTERY/CHARGING SYSTEM/ A.C. GENERATOR

---

Hold the flywheel with the universal holder  
and tighten the flywheel nut.

**Torque:** 3.5~4.5kgf-m

 Special

Universal Holder            E017

Install the cooling fan.

**Torque:** 0.6~1.0kgf-m

Install the fan cover and tighten bolts.

## IGNITION SYSTEM

SERVICE INFORMATION-----	15- 3
CDI UNIT INSPECTION-----	15- 5
IGNITION COIL-----	15- 7
PULSER COIL -----	15- 8
IGNITION TIMING INSPECTION-----	15- 8

# 15. IGNITION SYSTEM

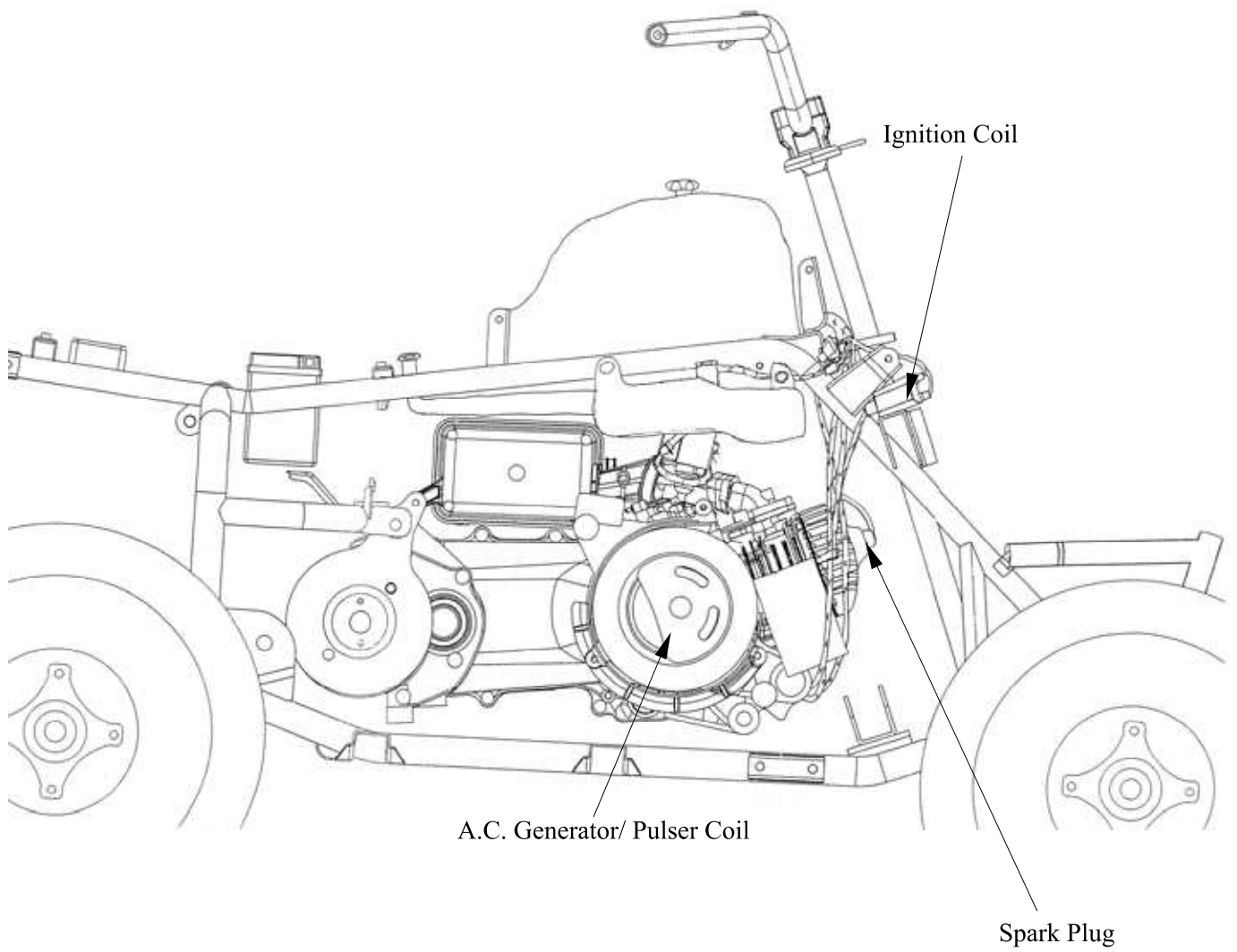



# 15. IGNITION SYSTEM

## IGNITION CIRCUIT (Mongoose/KXR 90)

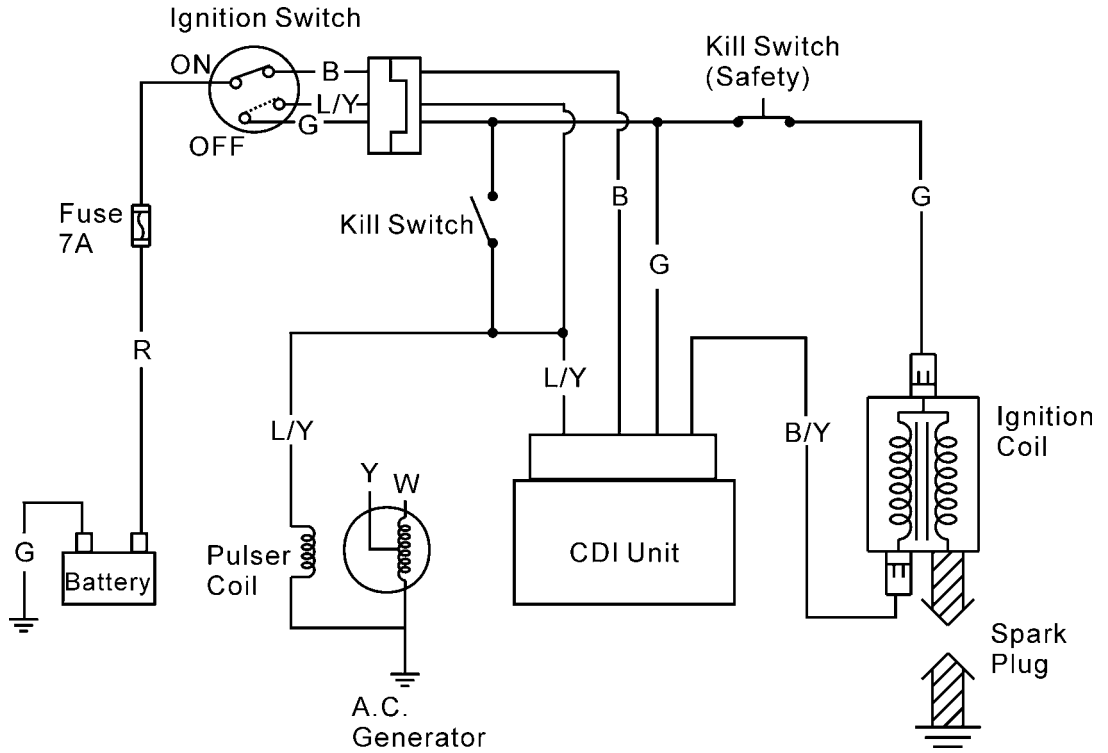

## IGNITION CIRCUIT (Mongoose/KXR 50)

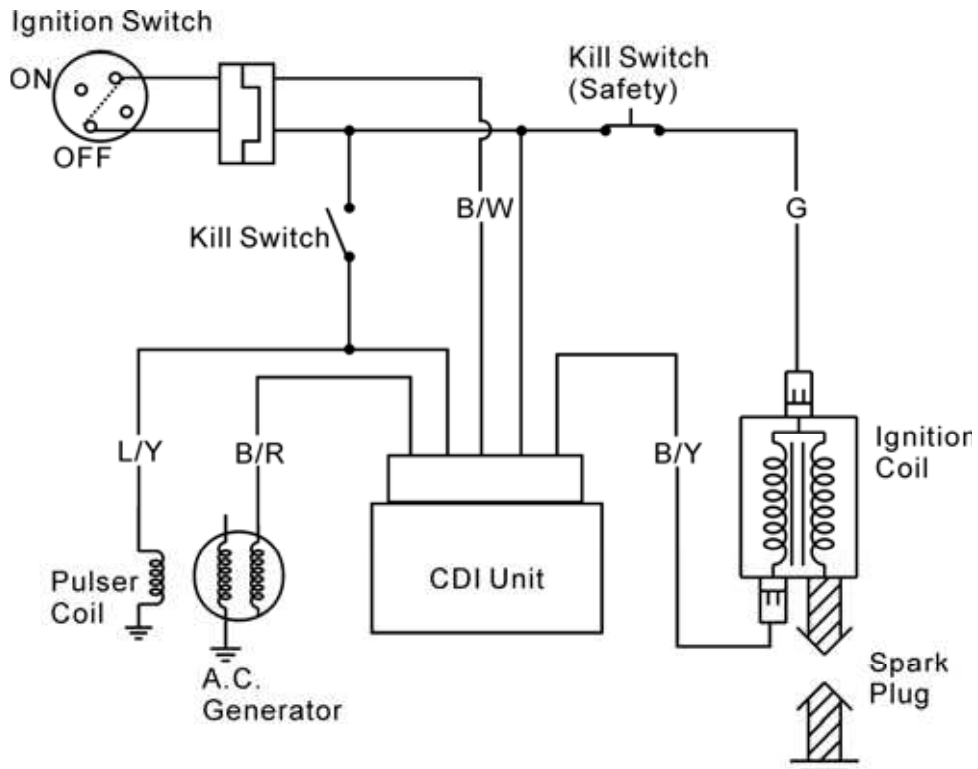

# 15. IGNITION SYSTEM

## SERVICE INFORMATION

### GENERAL INSTRUCTIONS

- Check the ignition system according to the sequence specified in the Troubleshooting.
- The ignition system adopts ignition unit, change gear control and the ignition timing cannot be adjusted.
- If the timing is incorrect, inspect the ignition unit, A.C. generator, change gear control and replace any faulty parts. Inspect the ignition unit with a ignition unit tester
- Loose connector and poor wire connection are the main causes of faulty ignition system. Check each connector before operation.
- Use of spark plug with improper heat range is the main cause of poor engine performance.
- The inspections in this section are focused on maximum voltage. The inspection of ignition coil resistance is also described in this section.
- Inspect the spark plug referring to chapter 3.

### SPECIFICATIONS (Mongoose/KXR 90)

Item		Standard	
Spark plug	Standard type	NGK-C7HSA	
Spark plug gap		0.6~0.7mm	
Ignition timing	“F” mark Full advance	28°±1°BTDC/4000RPM	
Ignition coil resistance (20°C)	Primary coil	2.2~2.6Ω	
	Secondary coil	without plug cap	3.14KΩ
		with plug cap	8.39KΩ
Pulser coil resistance (20°C)		121.1Ω	

### SPECIFICATIONS (Mongoose/KXR 50)

Item		Standard	
Spark plug	Standard type	BR8HAS	
Spark plug gap		0.6~0.7mm	
Ignition timing	“F” mark Full advance	15°BTDC/1700±100rpm	
Ignition coil resistance (20°C)	Primary coil	3.7~15.2Ω	
	Secondary coil	without plug cap	3.51KΩ
		with plug cap	8.81KΩ
Pulser coil resistance (20°C)		80~160Ω	

# 15. IGNITION SYSTEM

## TROUBLESHOOTING

### High voltage too low

- Weak battery or low engine speed
- Loose ignition system connection
- Faulty ignition unit

- Faulty ignition coil

- Faulty pulser coil

### Normal high voltage but no spark at plug

- Faulty spark plug
- Electric leakage in ignition secondary circuit
- Faulty ignition coil

### Good spark at plug but engine won't start

- Faulty ignition unit or incorrect ignition timing
- Faulty change gear control unit
- Improperly tightened A.C. generator flywheel

### No high voltage

- Faulty ignition switch
- Faulty ignition unit
- Poorly connected or broken ignition unit ground wire
- Dead battery or faulty regulator/rectifier
- Faulty ignition coil connector
- Faulty pulser coil

# 15. IGNITION SYSTEM

## CDI UNIT INSPECTION

Remove seat. (⇒2-3)

Disconnect the CDI coupler and remove the CDI unit.

Measure the resistance between the terminals using the electric tester.

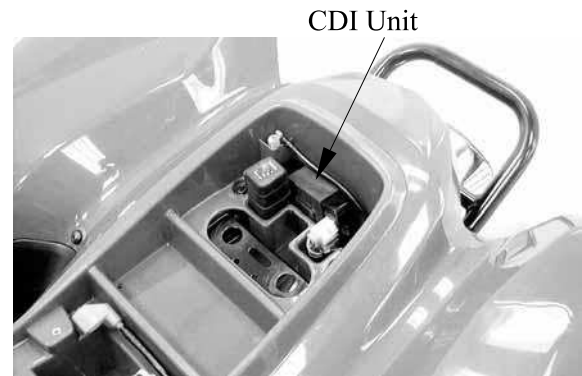

- Due to the semiconductor in circuit, it is necessary to use a specified tester for accurate testing. Use of an improper tester in an improper range may give false readings.
- Use a YF-3501 Electric Tester.
- In this table, “Needle swings then returns” indicates that there is a charging current applied to a condenser. The needle will then remain at “∞” unless the condenser is discharged.

Mongoose/KXR 90(OFF ROAD) Unit: MΩ

Probe⊕ (-)Probe	Black	Black/ Yellow	Blue/ Yellow	Green
Black		∞	∞	∞
Black/ Yellow	∞		∞	∞
Blue/ Yellow	∞	∞		∞
Green	4.9~5.5	4.9~5.5	4.9~5.5	

Note: The readings in this table are taken with a YF-3501 Tester.

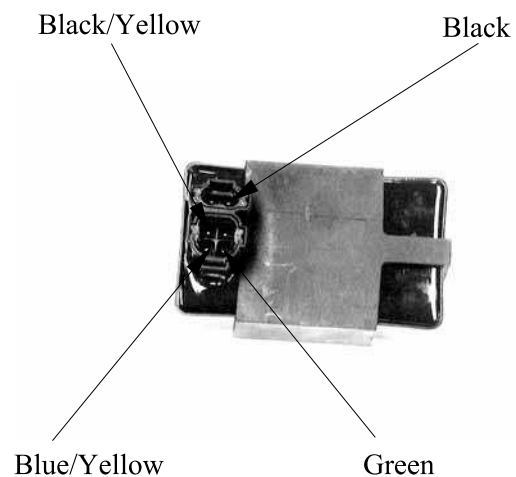

# 15. IGNITION SYSTEM

KXR 90(ON ROAD) Unit: MΩ

Probe⊕ (-)Probe	Black	Black/ Yellow	Blue/ Yellow	Green
Black		∞	∞	∞
Black/ Yellow	∞		∞	∞
Blue/ Yellow	∞	∞		∞
Green	6.1~6.8	6.1~6.8	6.1~6.8	

Note: The readings in this table are taken with a YF-3501 Tester.

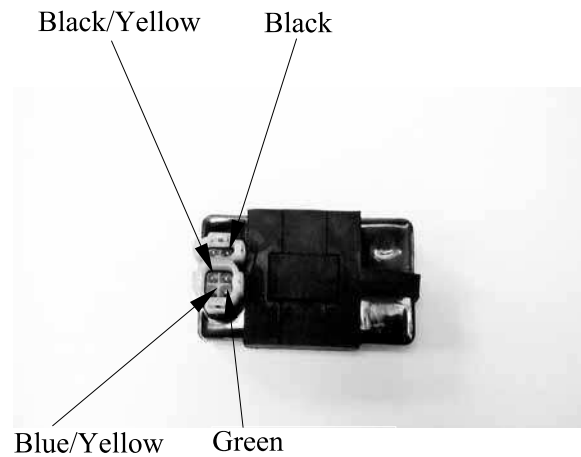

Mongoose/KXR 50(OFF ROAD) Unit: MΩ

Probe⊕ (-)Probe	Black/ Yellow	Black/ Red	Black/ White	Blue/ Yellow	Green
Black/ Yellow		∞	∞	∞	∞
Black/ Red	∞		∞	15.73	4.63
Black/ White	∞	8.52		∞	∞
Blue/ Yellow	∞	∞	∞		∞
Green	∞	∞	∞	8.07	

Note: The readings in this table are taken with a YF-3501 Tester.

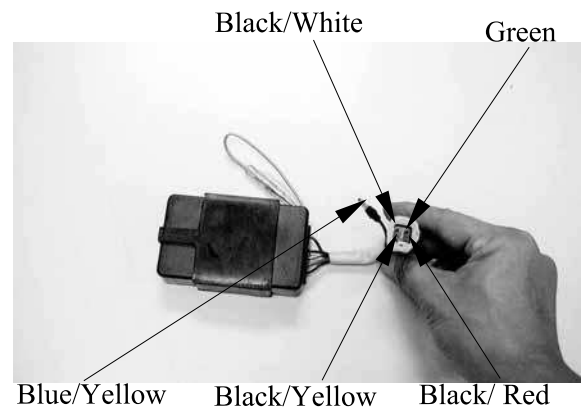

KXR 50(ON ROAD) Unit: MΩ

Probe⊕ (-)Probe	Black/ Yellow	Black/ Red	Black/ White	Blue/ Yellow	Green
Black/ Yellow		∞	∞	∞	∞
Black/ Red	∞		∞	∞	9.98
Black/ White	∞	10.2		∞	∞
Blue/ Yellow	∞	∞	∞		∞
Green	∞	∞	∞	6.91	

Note: The readings in this table are taken with a YF-3501 Tester.

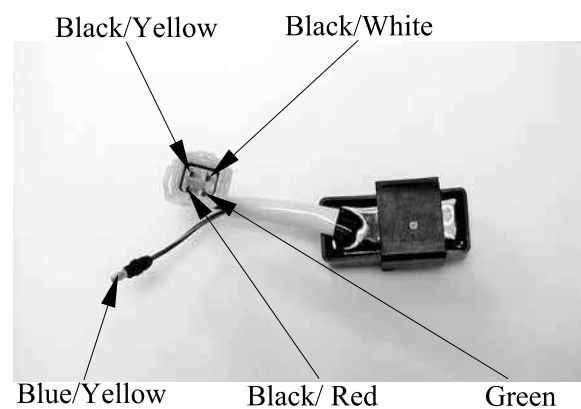

# 15. IGNITION SYSTEM

## IGNITION COIL

### REMOVAL

Remove the spark plug cap.  
 Disconnect the ignition coil wires and  
 remove the ignition coil bolt and ignition  
 coil.



Ignition Coil

### INSPECTION

#### CONTINUITY TEST

The CDI unit is not adjustable. If the timing is incorrect, inspect the CDI unit, pulser coil and A.C. generator and replace any faulty parts.

Measure the resistance between the ignition coil primary coil terminals.

#### Resistance:

**Mongoose/KXR 90) :** 2.2~2.6Ω/20°C

**Mongoose/KXR 50) :** 3.7~15.2Ω/20°C

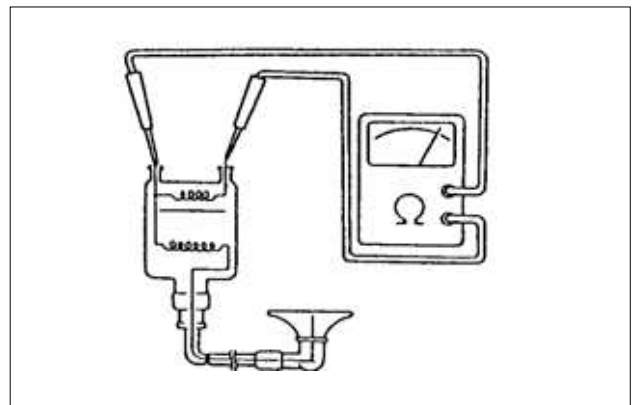

Measure the secondary coil resistances with and without the spark plug cap.

#### Resistances:

#### (Mongoose/KXR 90)

(with plug cap) : 8.39KΩ/20°C

(without plug cap) : 3.14KΩ/20°C

#### Mongoose/KXR 50)

(with plug cap) : 8.81KΩ/20°C

(without plug cap) : 3.51KΩ/20°C

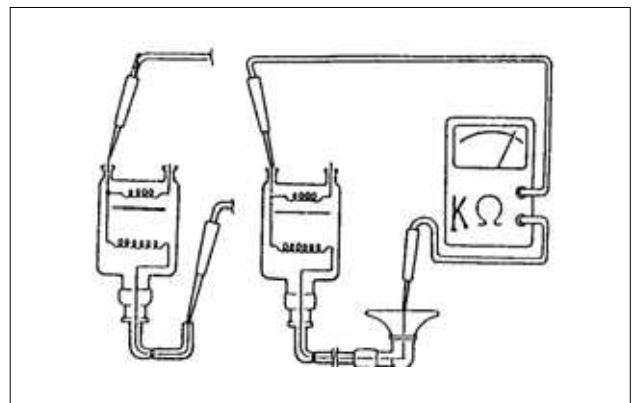

Correctly operate the tester following the manufacturer's instructions.

Note: The readings in this table are taken with a YF-3501 Tester.

## PULSER COIL INSPECTION

This test is performed with the stator installed in the engine.

Disconnect the A.C. generator connector.

Measure the pulser coil resistance between the blue/yellow and green wire terminals.

**Resistance:**

**Mongoose/KXR 90):**  $121.1\Omega/20^{\circ}\text{C}$

**Mongoose/KXR 50):**  $80\sim 160\Omega/20^{\circ}\text{C}$

Note: The readings in this table are taken with a YF-3501 Tester.

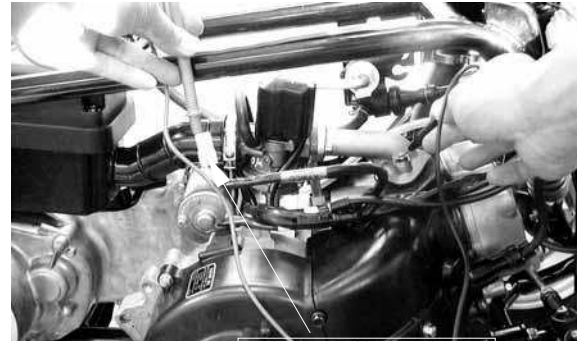

Pulser Coil Lead

## REMOVAL

Refer to chapter 14 for the A.C. generator removal.



## IGNITION TIMING INSPECTION

The CDI unit is not adjustable. If the ignition timing is incorrect, inspect the CDI unit, pulser coil and A.C. generator and replace any faulty parts.

Remove the fan cover.

Warm up the engine and check the ignition timing with a timing light.

When the engine is running at the ignition timing is correct if the "F" mark aligns with the index mark within  $\pm 2^{\circ}$ .

**Ignition Timing:**

**Mongoose/KXR 90):** BTDC $28^{\circ}/4000\text{rpm}$

**Mongoose/KXR 50):** BTDC $15^{\circ}/1700\text{rpm}$

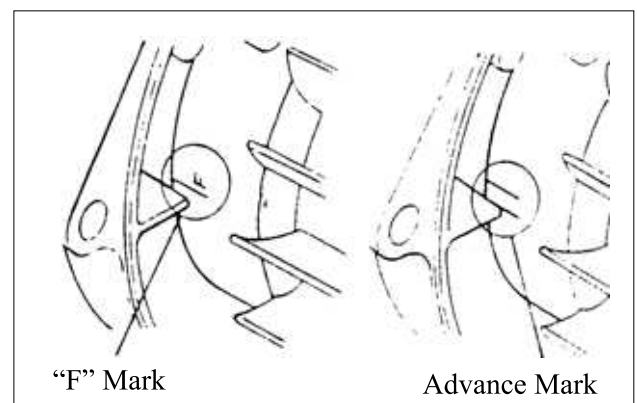

"F" Mark

Advance Mark

## STARTING SYSTEM

SERVICE INFORMATION-----	16- 2
STARTER MOTOR -----	16- 3
STARTER RELAY -----	16- 6
STARTER CLUTCH (Mongoose/KXR 90)-----	16- 7
STARTER PINION (Mongoose/KXR 50) -----	16- 9



# 16. STARTING SYSTEM

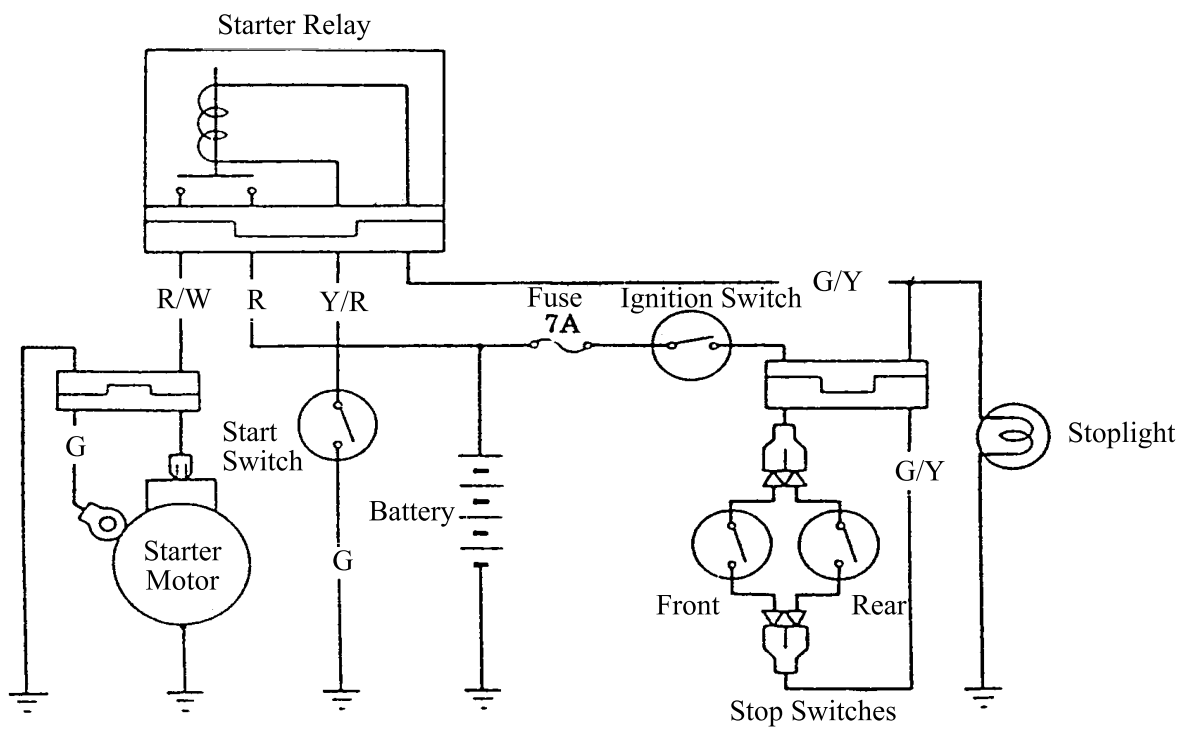
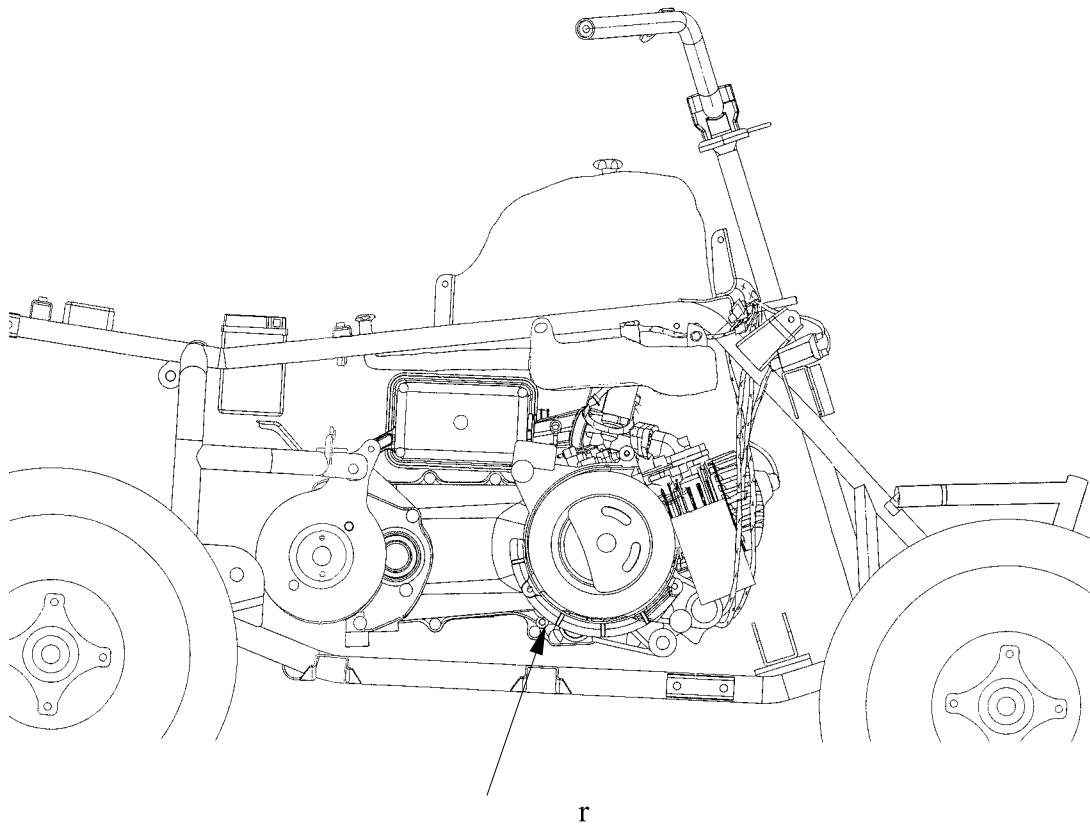

# 16. STARTING SYSTEM

## SERVICE INFORMATION

### GENERAL INSTRUCTIONS

- The removal of starter motor can be accomplished with the engine installed.

### TROUBLESHOOTING

#### **Starter motor won't turn**

- Fuse burned out
- Weak battery
- Faulty ignition switch
- Faulty starter clutch
- Faulty front or rear stop switch
- Faulty starter relay
- Poorly connected, broken or shorted wire
- Faulty starter motor
- Faulty change gear control unit

#### **Lack of power**

- Weak battery
- Loose wire or connection
- Foreign matter stuck in starter motor or gear

#### **Starter motor rotates but engine does not start**

- Faulty starter clutch
- Starter motor rotates reversely
- Weak battery

## 16. STARTING SYSTEM

### STARTER MOTOR

#### REMOVAL

- \* Before removing the starter motor, turn the ignition switch OFF and remove the battery ground. Then, turn on the ignition switch and push the starter button to see if the starter motor operates properly.

Disconnect the starter motor cable. Remove two mounting bolts at the starter motor attaching left crankcase, then remove the starter motor. (Mongoose/KXR 90's starter motor is located on the engine. Mongoose/KXR 50's starter motor is located under the engine.)

#### DISASSEMBLY

Remove the two starter motor case screws, front cover, motor case and other parts.

#### INSPECTION

Inspect the removed parts for wear, damage or discoloration and replace if necessary. Clean the commutator if there is metal powder between the segments.

Check for continuity between pairs of the commutator segments and there should be continuity. Also, make a continuity check between individual commutator segments and the armature shaft. There should be no continuity.

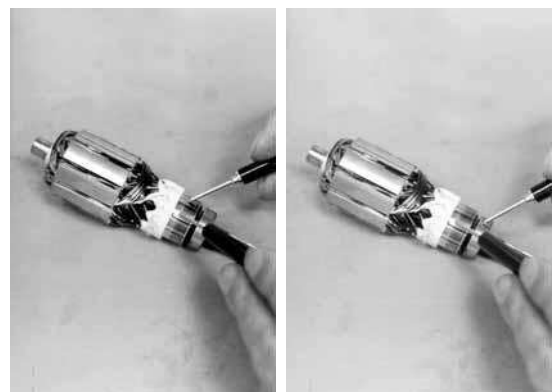
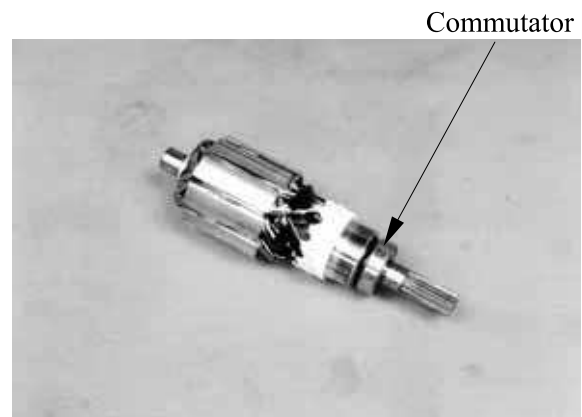
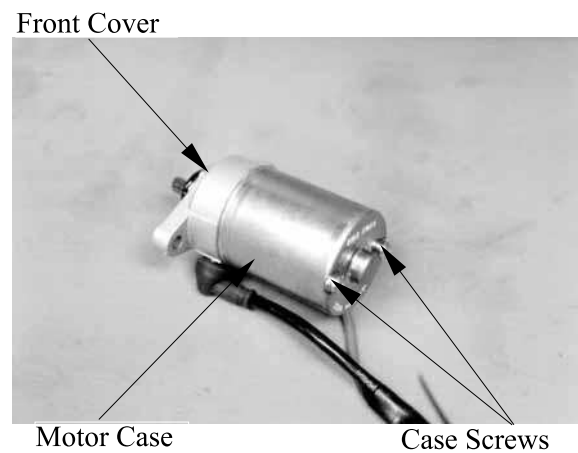
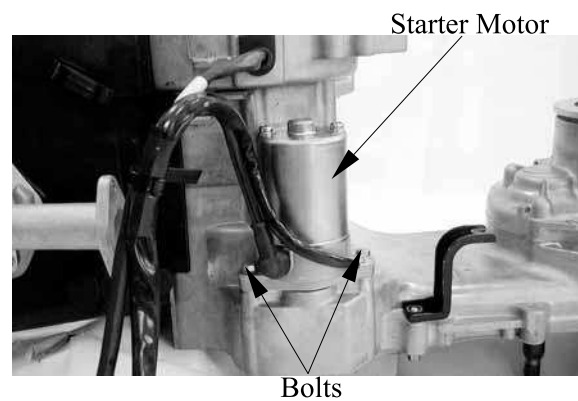

# 16. STARTING SYSTEM

## STARTER MOTOR CASE CONTINUITY CHECK

Check to confirm that there is no continuity between the starter motor wire terminal and the motor front cover.

Also check for the continuity between the wire terminal and each brush.

Replace if necessary.

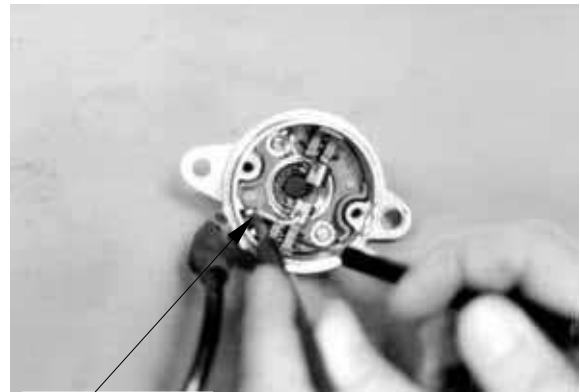

Wire Terminal

Measure the length of the brushes.

**Service Limit:** 8.5mm replace if below



Check for continuity between the brushes. If there is continuity, replace with new ones.



Check if the needle bearing in the front cover turns freely and has no excessive play.

Replace if necessary.

Check the dust seal for wear or damage.

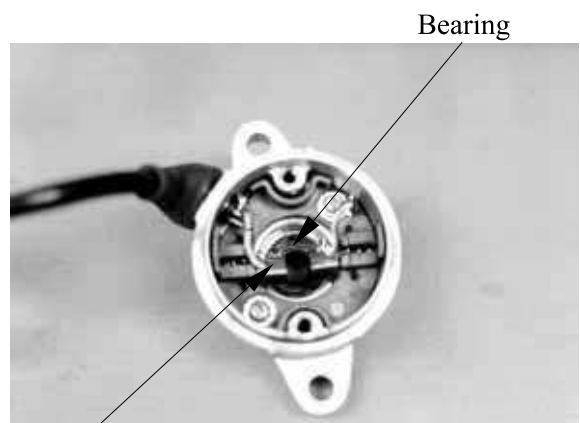

Dust Seal

# 16. STARTING SYSTEM

## ASSEMBLY

Apply grease to the dust seal in the front cover.  
Install the brushes onto the brush holders.  
Apply a thin coat of grease to the two ends of the armature shaft.  
Insert the commutator into the front cover.

\*

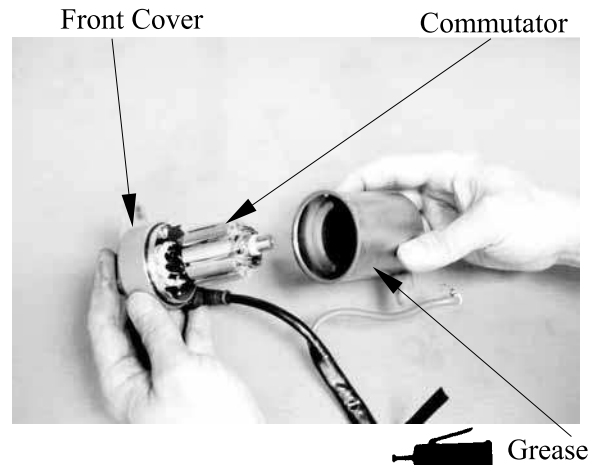

Install a new O-ring to the front cover.  
Install the starter motor case, aligning the tab on the motor case with the groove on the front cover.  
Tighten the starter motor case screws.

\*

When assembling the front cover and motor case, slightly press down the armature shaft to assemble them.

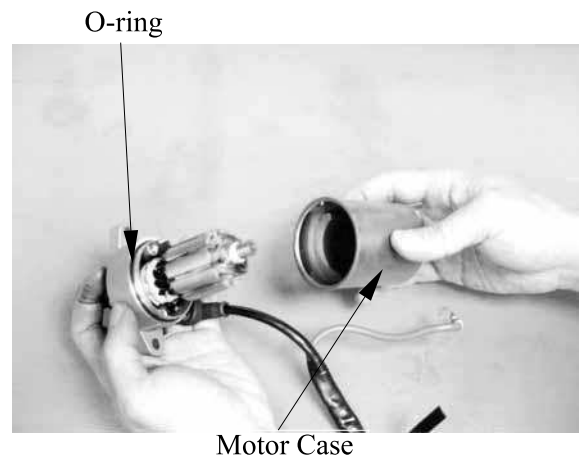

## STARTER MOTOR INSTALLATION

Connect the starter motor cable connector  
Check the O-ring for wear or damage and replace it if necessary.

Apply grease to the O-ring and install the starter motor.

Tighten the two mounting bolts.

**Torque:** 0.8~1.2kgf-m

\*

The starter motor cable connector must be installed properly.

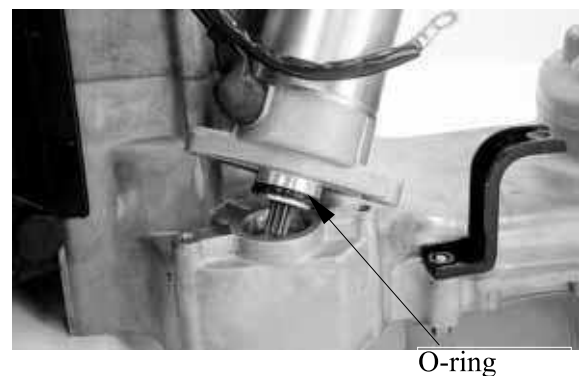

## 16. STARTING SYSTEM

### STARTER RELAY

#### INSPECTION

Remove the seat. (Refer to the chapter 2)  
Turn the ignition switch ON and the starter relay is normal if you hear a click when the starter button is depressed.

If there is no click sound:

- Inspect the starter relay voltage
- Inspect the starter relay ground circuit
- Check for continuity between the starter relay yellow/red and green/red wire terminals



#### STARTER RELAY VOLTAGE INSPECTION

Connect a 12V battery across the starter relay yellow/red and green/red wire terminals.

Connect an electric tester between the starter relay large terminals and check for continuity between the two terminals.

The relay is normal if there is continuity.  
Replace the starter relay with a new one if there is no continuity.

Starter Relay (Mongoose/KXR 90)

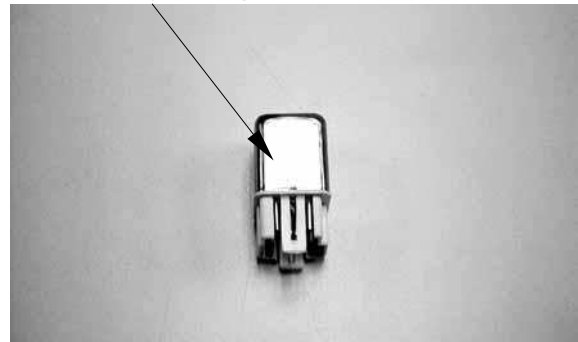

Starter Relay (Mongoose/KXR 50)



# 16. STARTING SYSTEM

## STARTER PINION (Mongoose/KXR 90)

### REMOVAL

Remove the left crankcase cover and drive pulley face. (Refer to chapter 9)  
Remove the starter one-way clutch drive nut.

Special

Lock nut socket wrench E015

Remove starter one-way clutch drive.

Special

Start clutch puller E006

Remove the reduction gear case.  
Remove the reduction gear.

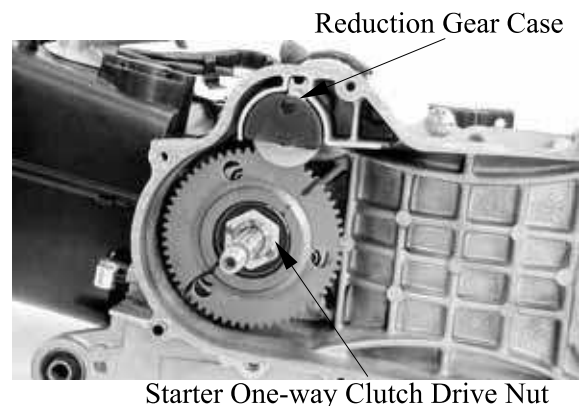

### INSTALLATION

Install each washer to the top and bottom of the reduction gear.  
Apply grease to the reduction gear shaft forcing part.  
Then, install in the reverse order of removal.

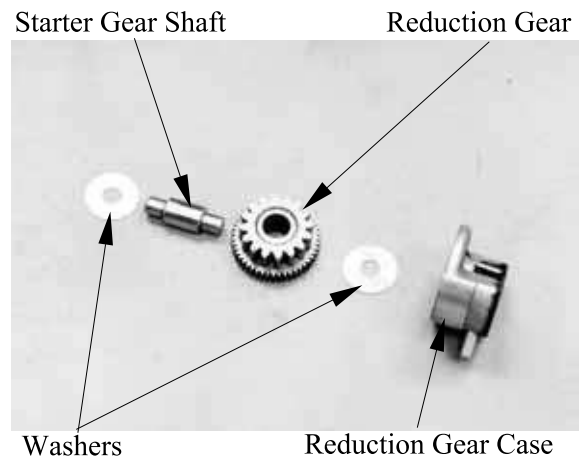

## STARTER ONE-WAY CLUTCH DISASSEMBLY

Remove the 32mm lock nut with special tool.  
Take the starter one-way clutch drive gear off.

Special

Lock nut socket wrench E015

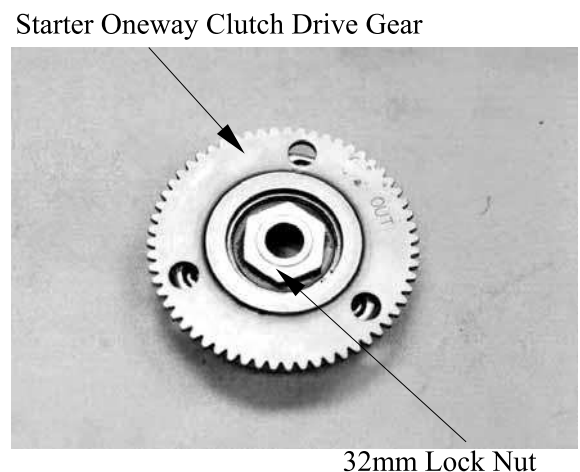

# 16. STARTING SYSTEM

## INSPECTION

Inspect the starter one-way clutch drive gear teeth for burrs/chips/roughness/wear.

Inspect the starter one-way clutch drive gear contacting surfaces for pitting/wear/damage.

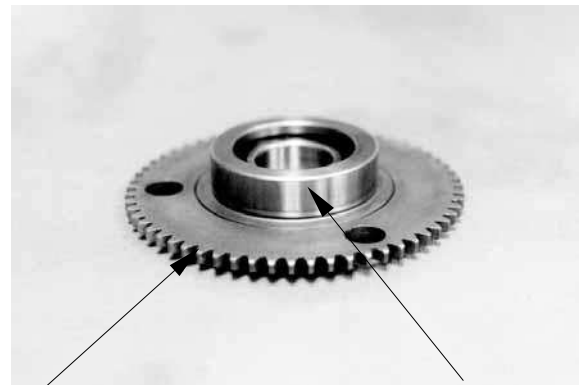

Teeth

Contacting Surfaces

Push the weight roller to arrow direction for unsmooth operation. → Replace starter clutch assembly.

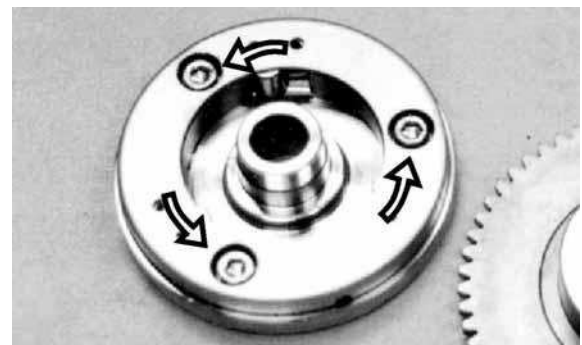

## ASSEMBLY

Install the starter one-way clutch driver gear in the reverse order of removal.

Do not reuse the starter clutch bolts that have been removed.

◆ **Torque:** 5.0~6.0kgf-m

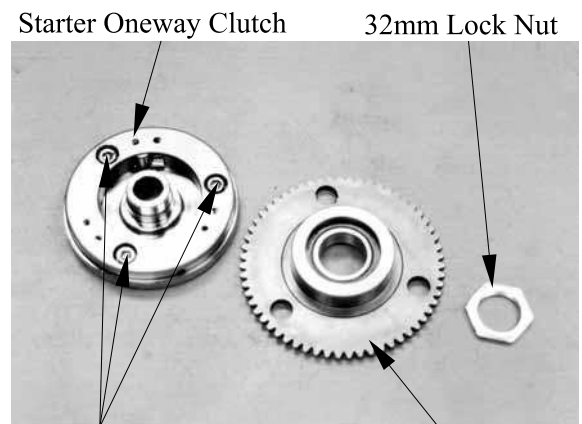

Starter Clutch Bolts

Starter Oneway Clutch Drive Gear

### Check starter clutch operation.

Clutch operation checking steps:

- ◆ Install the starter wheel gear to the starter clutch, and hold the starter clutch.
- ◆ When turning the wheel gear clockwise (1) the starter clutch and the wheel gear should be engaged. If not, the starter clutch is faulty. Replace it.
- ◆ When turning the wheel gear counterclockwise (2), the wheel gear should turn freely. If not, the starter clutch is faulty. Replace it.

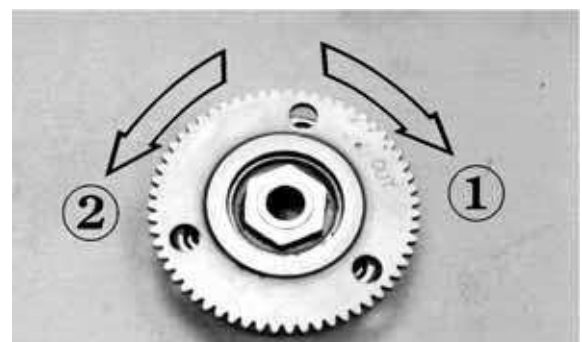



## STARTER PINION (Mongoose/KXR 50)

### REMOVAL

Remove the left crankcase cover.  
Remove the drive pulley.  
(Refer to chapter 9)

Remove the starter pinion cover.  
Remove the starter pinion.

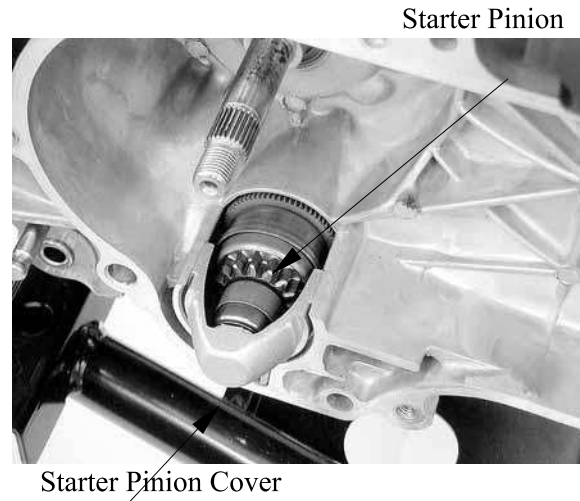

### Shaft Forcing Parts

### INSPECTION

Inspect the starter pinion seat for wear.  
Inspect the starter pinion for smooth operation.  
Inspect the starter pinion shaft forcing parts for wear and damage.

### INSTALLATION

Apply a small amount of grease to the starter pinion teeth.  
Install the starter pinion in the reverse order of removal.

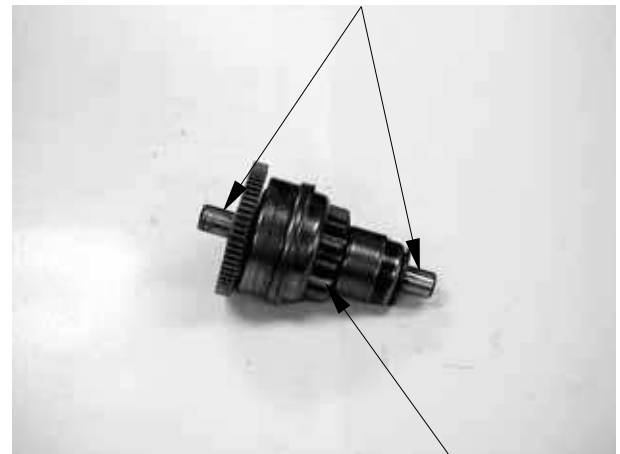

Starter Pinion

# **17. BULBS REMOVAL/INSTRUMENT/HORN** Mongoose/KXR 90/50

---

---

---

---

---

---

---

---

## **BULBS REMOVAL/INSTRUMENT/HORN**

---

BULBS REMOVAL-----	17- 1
INSTRUMENT (ON ROAD ONLY) -----	17- 4
HORN (ON ROAD ONLY)-----	17- 4

# 17. BULBS REMOVAL/INSTRUMENT/HORN Mongoose/KXR 90/50

## BULBS REMOVAL

### HEADLIGHT (ON ROAD ONLY)

Remove the front fender. (See page 2-5)

Disconnect the headlight wire coupler.

Remove the rubber boot from the bulb socket.

Relax the lock clip to remove the bulb and replace with a new one.

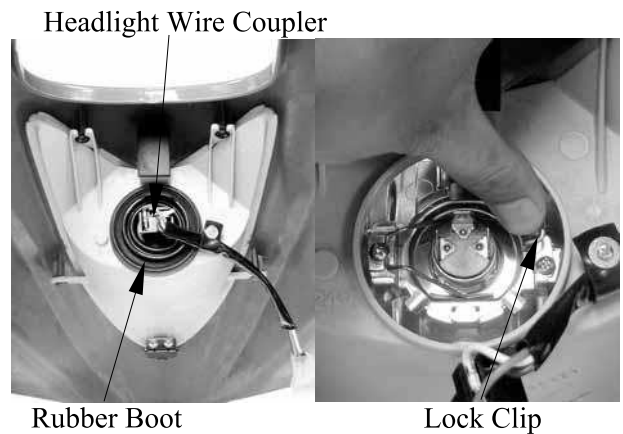

Install the bulb, aligning the bulb socket groove with the bulb tab and set the lock clip.

Install the rubber boot.

Install the front fender in the reverse order of removal.

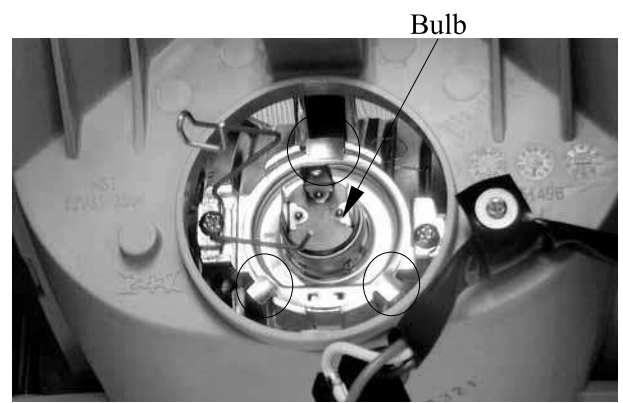

### TAIL/BRAKE LIGHT

Remove the two screws and then remove lens.

Remove the bulb by turning it counterclockwise and replace the bulb with a new one.

Installation is in the reverse order of removal.

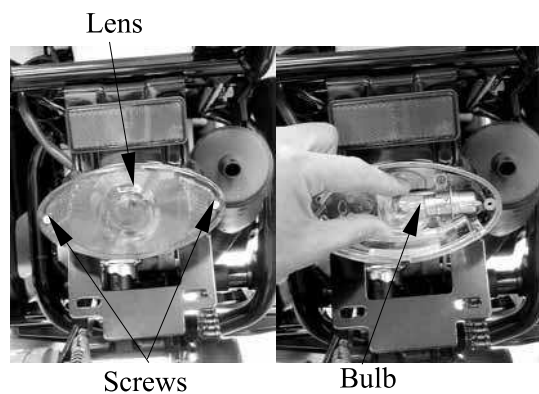

# 17. BULBS REMOVAL/INSTRUMENT/HORN Mongoose/KXR 90/50

## INDICATOR LIGHTS

Remove the handlebar cover (see page 2-3) and raise it.

Remove the bulb sockets by pulling them out.

Pull the bulb out of the socket and replace it with a new one.

Installation is in the reverse order of removal.

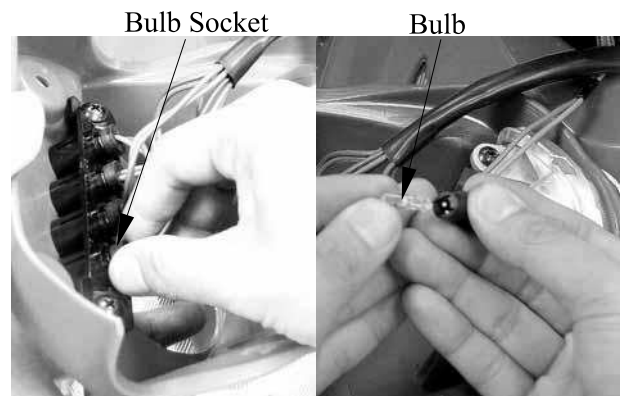

## POSITION LIGHT (ON ROAD ONLY)

Pull the bulb socket out of the position light case.

Pull the bulb out of the socket and replace it with a new one.

Installation is in the reverse order of removal.

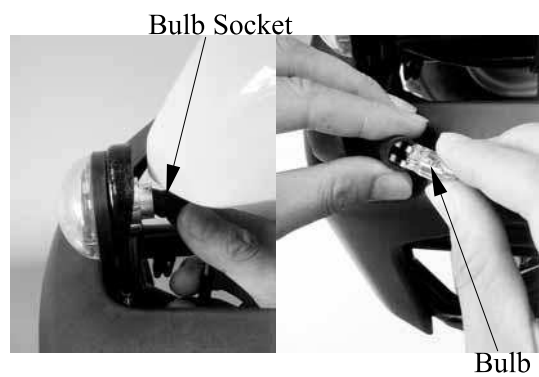

## FRONT TURN SIGNAL LIGHT (ON ROAD ONLY)

Remove the turn signal light lens by a flat screwdriver.

Pull the bulb socket out from the signal light case and remove bulb.

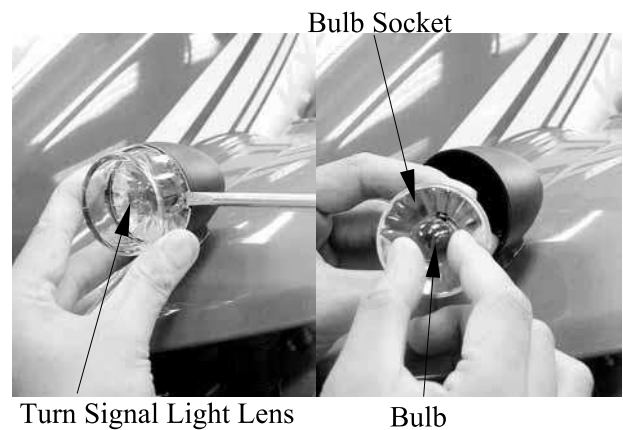

Install the bulb, aligning the bulb socket groove with the bulb tab.



# 17. BULBS REMOVAL/INSTRUMENT/HORN Mongoose/KXR 90/50

Install the bulb socket, aligning the bulb socket groove with the turn signal case tab.  
Install the turn signal lens, aligning the turn signal lens groove with the turn signal case tab.



## REAR TURN SIGNAL LIGHT (ON ROAD ONLY)

Remove the screw and remove the turn signal light lens.  
Pull the bulb socket outside from the signal light case and remove bulb.

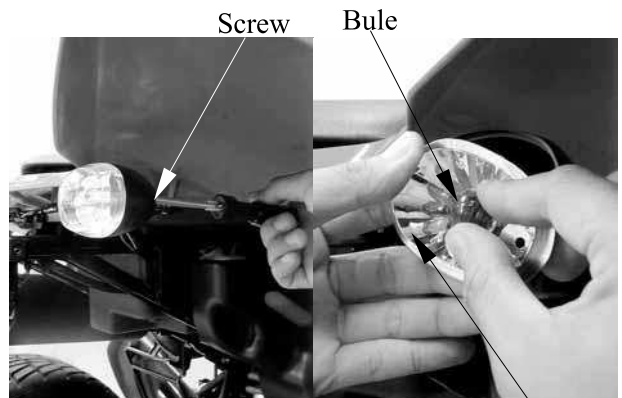

Bulb Socket

Install the bulb, aligning the bulb socket groove with the bulb tab.

Install the bulb in the reverse order of removal.



# 17. BULBS REMOVAL/INSTRUMENT/HORN Mongoose/KXR 90/50

## INSTRUMENT (ON ROAD) REMOVAL

Remove the handlebar cover. (See page 2-3)

Disconnect the meter connectors.

Remove the two screws and then remove the instrument.

Installation is in the reverse order of removal.

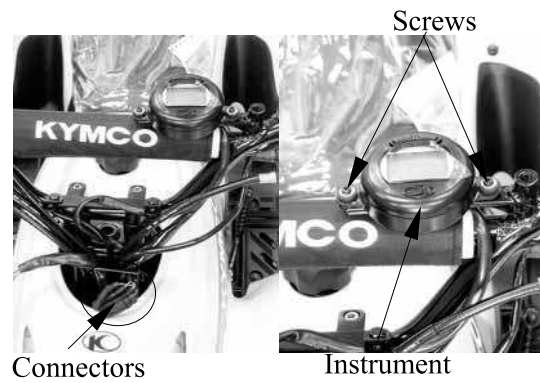

## HORN (ON ROAD)

### REMOVAL

Disconnect the horn wire connectors.

Remove the bolt and remove horn.

Installation is in the reverse order of removal.

