

**By KWANG YANG Motor Co., Ltd.
First Edition, Dec. 2008
All rights reserved. Any reproduction or
unauthorized use without the written permission of
KWANG YANG Motor Co., Ltd.
is expressly prohibited.
T100-LAA0CD-IT**

PREFACE

This Service Manual describes the technical features and servicing procedures for the **MXU 500 IRS**.

Section 1 contains the precautions for all operations stated in this manual. Read them carefully before any operation is started.

Section 2 is the removal/installation procedures for the frame covers which are subject to higher removal/installation frequency during maintenance and servicing operations.

Section 3 describes the inspection/adjustment procedures, safety rules and service information for each part, starting from periodic maintenance.

Sections 4 through 12 give instructions for disassembly, assembly and adjustment of engine parts. Section 13 through 16 is the removal/ installation of chassis. Section 17 through 21 states the testing and measuring methods of electrical equipment.

Most sections start with an assembly or system illustration and troubleshooting for the section. The subsequent pages give detailed procedures for the section.

The information and contents included in this manual may be different from the vehicle in case specifications are changed. KYMCO reserves the right to make changes at any time without notice and without incurring any obligation.

TABLE OF CONTENTS

| | | |
|-------------------------|--|----|
| | GENERAL INFORMATION | 1 |
| | FRAME COVERS /EXHAUST MUFFLER | 2 |
| | INSPECTION/ADJUSTMENT | 3 |
| ENGINE | LUBRICATION SYSTEM | 4 |
| | FUEL SYSTEM | 5 |
| | COOLING SYSTEM | 6 |
| | ENGINE REMOVAL | 7 |
| | CYLINDER HEAD/VALVES | 8 |
| | CYLINDER/PISTON | 9 |
| | DRIVE PULLEY/DRIVEN PULLEY/ CLUTCH | 10 |
| | FINAL REDUCTION/ TRANSMISSION SYSTEM | 11 |
| | LEFT CRANKCASE/CRANKSHAFT/ BALANCE SHAFT | 12 |
| CHASSIS | DRIVE TRAIN | 13 |
| | FRONT WHEEL/FRONT SUSPENSION/ STEERING SYSTEM | 14 |
| | REAR WHEEL/AXLE/SHOCK ABSORBER/SWING ARM | 15 |
| | BRAKE SYSTEM | 16 |
| ELECTRICAL EQUIPMENT | BATTERY/CHARGING SYSTEM | 17 |
| | IGNITION SYSTEM | 18 |
| | STARTER SYSTEM | 19 |
| | LIGHTS/ SWITCHES | 20 |
| | WIRING DIAGRAMS | 21 |

KWANG YANG MOTOR CO., LTD.
Quality Technology Division
Education Department

GENERAL INFORMATION

| | | |
|---------------------|-------|------|
| SERIAL NUMBER | ----- | 1- 1 |
| SPECIFICATIONS | ----- | 1- 2 |
| SERVICE PRECAUTIONS | ----- | 1- 3 |
| TORQUE VALUES | ----- | 1-11 |
| SPECIAL TOOLS | ----- | 1-15 |
| LUBRICATION POINTS | ----- | 1-19 |

1. GENERAL INFORMATION

SERIAL NUMBER



(1) Location of Frame Serial Number

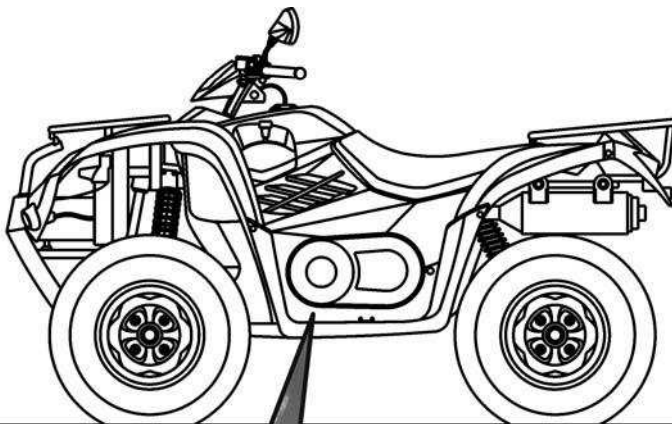

(1) Location of Engine Serial Number

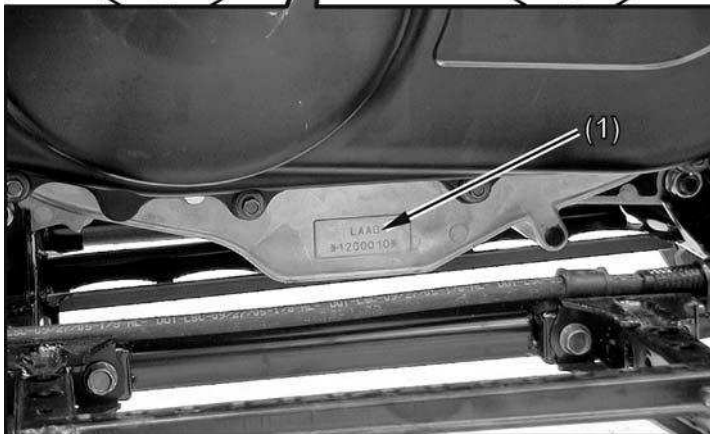

1. GENERAL INFORMATION

SPECIFICATIONS

| | | | |
|---------------------|-----------------------------|------------------------|-------------------------|
| Model No. | | LAA0CA/LAA0CD | |
| Name & Type | | MXU 500 IRS | |
| Overall length | | 2203 mm | |
| Overall width | | 1223 mm | |
| Overall height | | 1243 mm | |
| Wheel base | | 1297 mm | |
| Engine type | | D.O.H.C. | |
| Displacement | | 498.5 CC | |
| Fuel used | | 92# nonleaded gasoline | |
| Dry weight | Front wheel | 162 kg | |
| | Rear wheel | 155kg | |
| | Total | 317kg /318kg | |
| Curb weight | Front wheel | 170 kg | |
| | Rear wheel | 164 kg | |
| | Total | 334kg /335kg | |
| Tires | Front wheel | 25X8R-12 | |
| | Rear wheel | 25X10R-12 | |
| Ground clearance | | 241 mm | |
| Min. turning radius | | | |
| Engine | Starting system | | Electric/Recoil starter |
| | Type | | Gasoline, 4-stroke |
| | Cylinder arrangement | | Single cylinder |
| | Combustion chamber type | | Semi-sphere |
| | Valve arrangement | | DOHC.,chain drive |
| | Bore x stroke | | 92X75 mm |
| | Compression ratio | | 10.5:1 |
| | Compression pressure | | 15 kg/cm ² |
| | Intake valve (at 1mm lift) | Opens | 5° BTDC |
| | | Closes | 45° ABDC |
| | Exhaust valve (at 1mm lift) | Opens | 45° BBDC |
| | | Closes | 5° ATDC |
| | Valve clearance (cold) | Intake | 0.1 mm |
| | | Exhaust | 0.1 mm |
| | Idle speed (rpm) | | 1500 ±100rpm |
| | Cooling type | | Liquid cooled |

| | | | | |
|----------------------|----------------------------------|------------|--|-----------|
| Lubrication System | Lubrication type | | Forced pressure & Wet sump | |
| | Oil pump type | | Trochoid | |
| | Oil filter type | | Full-flow filtration | |
| | Oil capacity | | 3.6 L | |
| | Oil exchanging capacity | | 3.0 L | |
| | | | | |
| Fuel System | Air cleaner type & No | | Wet type element | |
| | Fuel capacity | | 17 L | |
| | Carburetor | Type | | KYMCO CVK |
| | | Main jet | ON ROAD | #128 |
| | | | OFF ROAD | #126 |
| VENTURE DIA | | 38mm | | |
| Electrical Equipment | Ignition System | | | |
| | Type | | Full transistor digital ignition | |
| | Ignition timing | | 5°/1500 rpm | |
| | Spark plug | | CR7E (NGK) | |
| | Spark plug gap | | 0.6~0.7mm | |
| Battery | Capacity | 12V18AH | | |
| Drive Train | Clutch type | | Wet, centrifugal automatic | |
| | Clutch operation system | | Automatic (V-belt) | |
| | Primary reduction system | | V-belt | |
| | Secondary reduction system | | Shaft drive | |
| | Forward drive high radio | | 8.770~30.067 | |
| | Forward drive low radio | | 16.279~55.814 | |
| | Reverse drive ratio | | 13.381~45.878 | |
| | FR/RR tire rolling circumference | | 1995/1995 mm | |
| Moving Device | Tire pressure | Front | 0.35 kgf/cm ² (35 Kpa, 5.0 psi) | |
| | | Rear | 0.32 kgf/cm ² (32Kpa, 4.5psi) | |
| | Turning angle | Left | 41° | |
| | | Right | 41° | |
| Brake system type | Front | Disk brake | | |
| | Rear | Disk brake | | |
| Suspension type | Front | Dual A-Arm | | |
| | Rear | Dual A-Arm | | |

1. GENERAL INFORMATION

SERVICE PRECAUTIONS

- Make sure to install new gaskets, O-rings, circlips, cotter pins, etc. when reassembling.

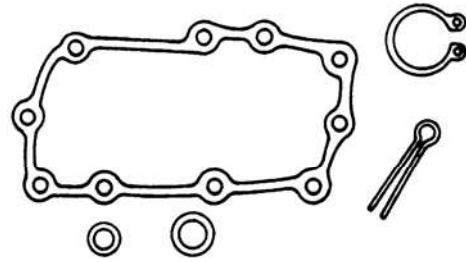

- When tightening bolts or nuts, begin with larger-diameter to smaller ones at several times, and tighten to the specified torque diagonally.

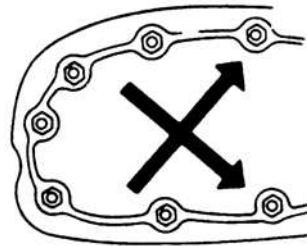

- Use genuine parts and lubricants.

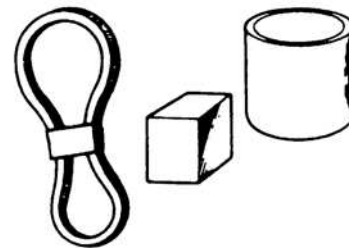

- When servicing the motorcycle, be sure to use special tools for removal and installation.



- After disassembly, clean removed parts. Lubricate sliding surfaces with engine oil before reassembly.

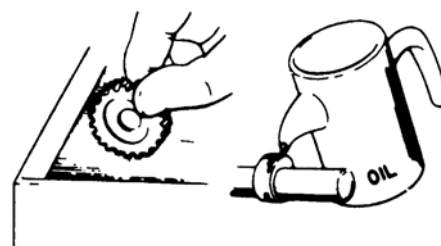

1. GENERAL INFORMATION

- Apply or add designated greases and lubricants to the specified lubrication points.

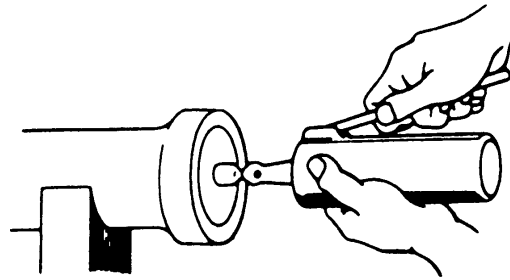

- After reassembly, check all parts for proper tightening and operation.

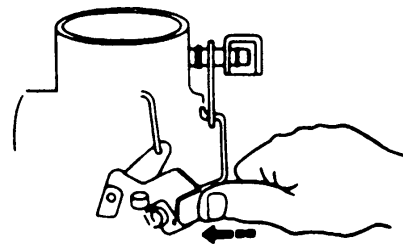

- When two persons work together, pay attention to the mutual working safety.

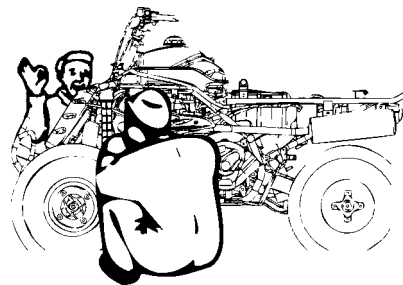

- Disconnect the battery negative (-) terminal before operation.
- When using a spanner or other tools, make sure not to damage the motorcycle surface.

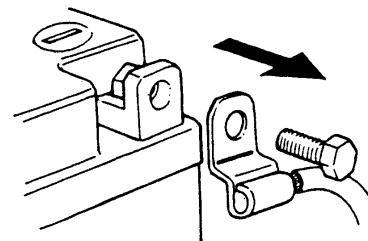

- After operation, check all connecting points, fasteners, and lines for proper connection and installation.
- When connecting the battery, the positive (+) terminal must be connected first.
- After connection, apply grease to the battery terminals.
- Terminal caps shall be installed securely.

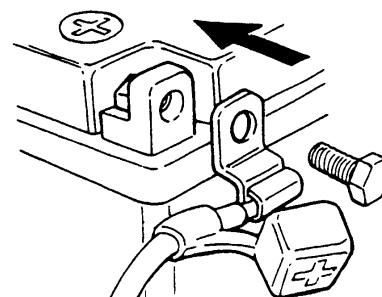

1. GENERAL INFORMATION

- If the fuse is burned out, find the cause and repair it. Replace it with a new one according to the specified capacity.

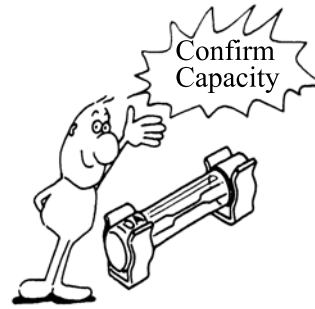

- After operation, terminal caps shall be installed securely.



- When taking out the connector, the lock on the connector shall be released before operation.

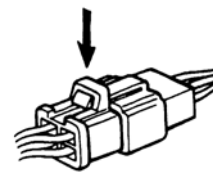

- Hold the connector body when connecting or disconnecting it.
- Do not pull the connector wire.

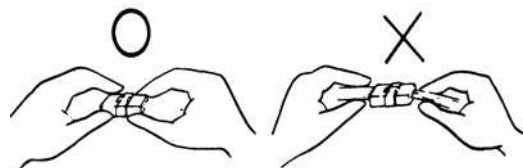

- Check if any connector terminal is bending, protruding or loose.

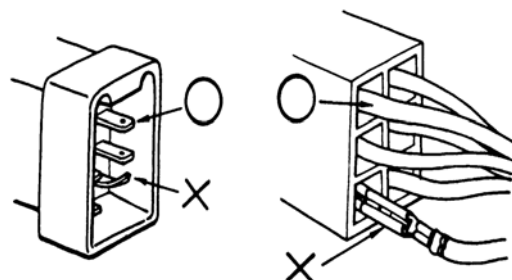

1. GENERAL INFORMATION

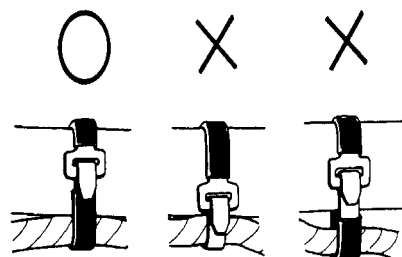
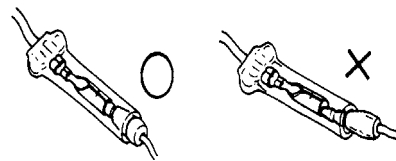
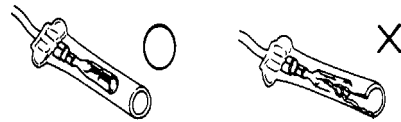
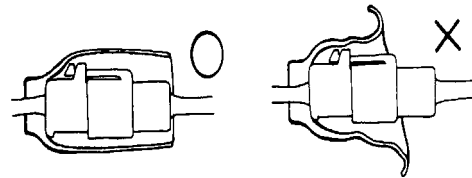
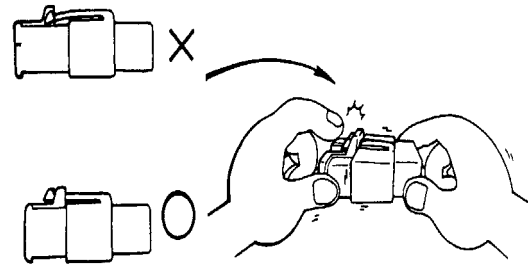

1. GENERAL INFORMATION

- After clamping, check each wire to make sure it is secure.

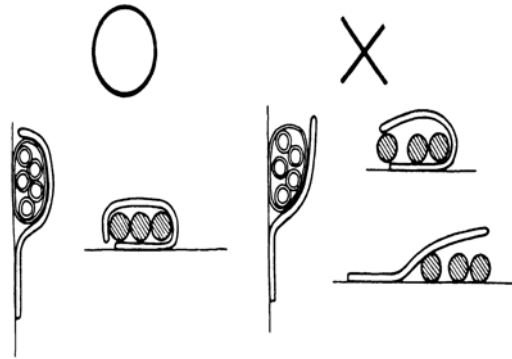

- Do not squeeze wires against the weld or its clamp.



- After clamping, check each harness to make sure that it is not interfering with any moving or sliding parts.

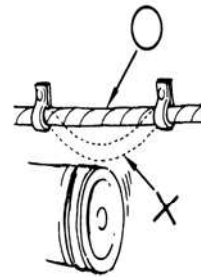

- When fixing the wire harnesses, do not make it contact the parts which will generate high heat.

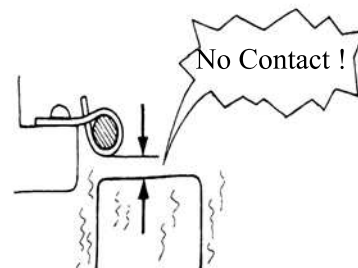

- Route wire harnesses to avoid sharp edges or corners. Avoid the projected ends of bolts and screws.
- Route wire harnesses passing through the side of bolts and screws. Avoid the projected ends of bolts and screws.

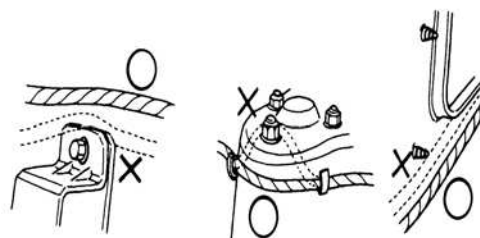

1. GENERAL INFORMATION

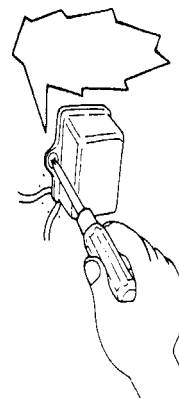
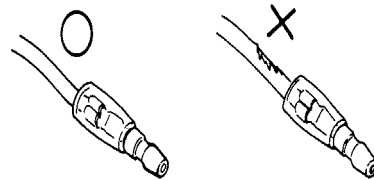
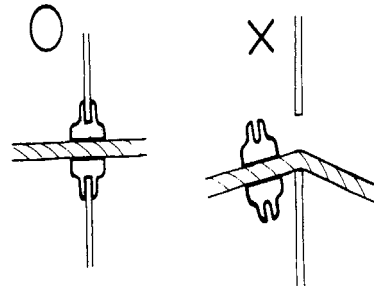
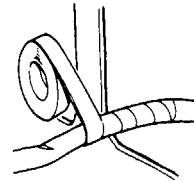
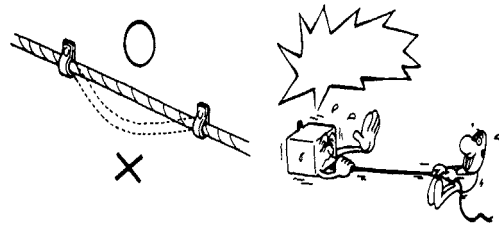

1. GENERAL INFORMATION

- After routing, check that the wire harnesses are not twisted or kinked.

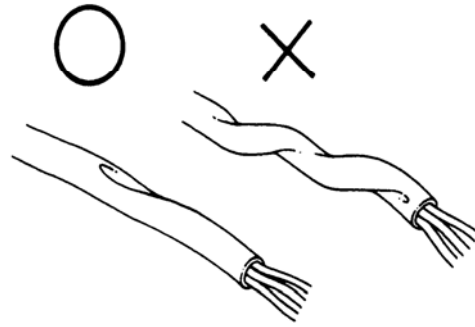

- Wire harnesses routed along with handlebar should not be pulled tight, have excessive slack or interfere with adjacent or surrounding parts in all steering positions.

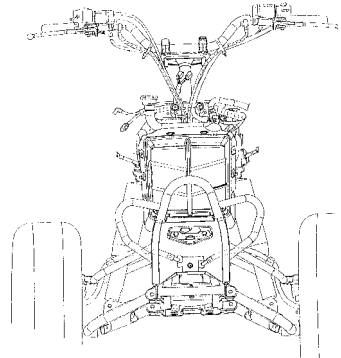

- When a testing device is used, make sure to understand the operating methods thoroughly and operate according to the operating instructions.

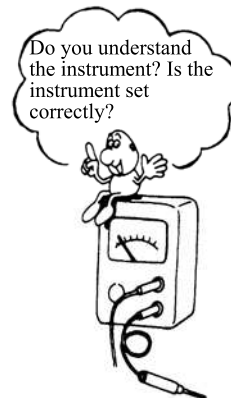

- Be careful not to drop any parts.



- When rust is found on a terminal, remove the rust with sand paper or equivalent before connecting.



1. GENERAL INFORMATION

■ Symbols:

The following symbols represent the servicing methods and cautions included in this service manual.



: Apply engine oil to the specified points. (Use designated engine oil for lubrication.)



: Apply grease for lubrication.



: Transmission Gear Oil (90#)



: Caution



: Warning

1. GENERAL INFORMATION

TORQUE VALUES ENGINE

| NO | ITEM | THREAD SIZE AND TYPE | TORQUE | | PR VALUES N.m |
|----|------------------------------|--------------------------|-----------|---------|---------------------|
| | | | N.m | kgf.m | |
| 1 | CRANKCASE SET | M6x1.0 | 11.8 | 1.2 | 11.8 |
| | | M6x1.0 | 11.8 | 1.2 | 11.8 |
| | | M6x1.0 | 11.8 | 1.2 | 11.8 |
| | | M6x1.0 | 11.8 | 1.2 | 11.8 |
| | | M6x1.0 | 11.8 | 1.2 | 11.8 |
| 2 | CYLINDER HEAD | BOLT UBS M10x210 | 47 | 4.8 | 47 |
| | | BOLT UBS M10x220 | 47 | 4.8 | 47 |
| | | SPECIAL BOLT M8x1.25 | 22.5 | 2.3 | 22.5 |
| | | SPECIAL BOLT M8x1.25 | 22.5 | 2.3 | 22.5 |
| | | SPECIAL BOLT M8x1.25 | 22.5 | 2.3 | 22.5 |
| | | SPECIAL BOLT M8x1.25 | 22.5 | 2.3 | 22.5 |
| 3 | HEAD COVER | M6x1.0 | 7.8~11.8 | 0.8~1.2 | 9.8 |
| 4 | SPARK PLUG | M10x1.0 | 9.8~13.7 | 1.0~1.4 | 11.8 |
| 5 | TAPPET ADJ. NUT | M5x0.5 | 6.9~10.8 | 0.7~1.1 | 8.9 |
| 6 | TENSIONER LIFTER | SHF M6x1.0 | 9.8~13.7 | 1.0~1.4 | 11.8 |
| 7 | SHAFT ROCKER ARM | SPECIAL SCREW M18x1.5 | 39.2~49 | 4.0~5.0 | 44.1 |
| 8 | CAM CHAIN TENSIONER PIVOT | SPECIAL BOLT M8x1.25 | 17.7~21.6 | 1.8~2.2 | 19.7 |

1. GENERAL INFORMATION

| | | | | | |
|----|---------------------------|-------------------------|-----------|---------|-------|
| 9 | ACG ONE WAY | BOLT SOCKET M8x1.25 | 17.7~21.6 | 1.8~2.2 | 19.7 |
| 10 | SPROCKET CAMSHAFT | SPECIAL BOLT M6x1.0 | 10.8~14.7 | 1.1~1.5 | 12.8 |
| 11 | ACG FLYWHEEL | N.F. M14 | 49~58.9 | 5.0~6.0 | 54 |
| 12 | OIL FILTER | M20x1.5 | 7.8~11.8 | 0.8~1.2 | 9.8 |
| 13 | HOLE CAP | M30x1.5 | 49~58.9 | 1.0~2.0 | 14.7 |
| 14 | NUT, FINAL SHAFT | M85X2.0 | 107.8 | 11 | 107.8 |
| 15 | L CASE DRAIN PLUG | M12x1.5 | 20~30 | 2~3 | 24.5 |
| 16 | WET CLUTCH | M25x1.5 | 137.2 | 14 | 137.2 |
| 17 | DRIVE FACE | M20x1.0 | 137.2 | 14 | 137.2 |
| 18 | GUIDE COMP., CAM CHAIN | SPECIAL BOLT M8x1.25 | 17.7~21.6 | 1.8~2.2 | 19.7 |
| 19 | PULLEY, DRIVEN | M16x1.5 | 98 | 10 | 98 |
| 20 | PIPE COMP., OIL | M16x1.5 | 34.3 | 3.5 | 34.3 |
| 21 | BEVEL GEAR, DRIVE | M20x1.0 | 137.2 | 14 | 137.2 |
| 22 | BEVEL GEAR., DRIVEN | M20x1.0 | 137.2 | 14 | 137.2 |
| 23 | PARK, ASSY | SPECIAL BOLT M8x1.25 | 17.7~21.6 | 1.8~2.2 | 19.7 |
| 24 | O4 BEARING | SPECIAL BOLT M8x1.25 | 27.5~31.4 | 2.8~3.2 | 30 |

| ITEM | THREAD SIZE AND TYPE | TORQUE | | PR VALUES N.m |
|--------------|-------------------------|--------|--------|---------------------|
| | | N.m | kg f.m | |
| PARKING BOLT | M12X1.25 | 29.5 | 3 | 30 |
| | M8x1.25 | 24.5 | 2.5 | 25 |

1. GENERAL INFORMATION

FRAME

| NO | ITEM | THREAD SIZE AND TYPE | TORQUE | | PR-È Kgfm |
|----|--|----------------------------|---------|---------|--------------|
| | | | Kgfm | Nm | |
| 1 | STEERING | | | | |
| | HANDLEBAR AND STEERING POST | M10X1.25 | 2.4~3.0 | 24~30 | 2.7 |
| | UPPER/LOWER HOUSING AND FRAME | M8X1.25 | 2.4~3.0 | 24~30 | 2.7 |
| | STEERING KNUCKLE AND TIE-ROD | M10X1.25 | 3.5~4.8 | 35~48 | 4.2 |
| | STEERING STEM AND TIE-ROD | M10X1.25 | 3.5~4.8 | 35~48 | 4.2 |
| | TIE-ROD LOCK NUT | M10X1.25 | 2.0~3.0 | 20~30 | 2.5 |
| | TIE-ROD LOCK NUT | M10X1.25 | 2.0~3.0 | 20~30 | 2.5 |
| | STEERING POST LOWER PIVOT | M10X1.25 | 5.0~6.1 | 50~61 | 5.5 |
| | BEARING FLANGE AND FRAME | M8X1.25 | 2.4~3.2 | 24~32 | 2.8 |
| 2 | WHEEL | | | | |
| | FRONT WHEEL AND FRONT HUB | M10X1.25 | 5.0~6.1 | 50~61 | 5.5 |
| | REAR WHEEL AND REAR HUB | M10X1.25 | 5.0~6.1 | 50~61 | 5.5 |
| | FRONT WHEEL HUB AND FRONT HALFSHAFT(CVJ) | M22X1.5 | 27~30 | 270~300 | 28 |
| | REAR WHEEL HUB AND REAR HALFSHAFT(CVJ) | M22X1.5 | 27~30 | 270~300 | 28 |
| | FRONT WHEEL HUB AND STUD AXLE(2WD ONLY) | M22X1.5 | 27~30 | 270~300 | 28 |
| 3 | FR SUSPENSION | | | | |
| | FRONT SHOCK UPPER JOINT AND FRAME | M10X1.25 | 4.1~5.6 | 41~56 | 4.8 |
| | FRONT UPPER ARM AND FRAME | M10X1.25 | 4.1~5.6 | 41~56 | 4.8 |
| | FRONT LOWER ARM AND FRAME | M10X1.25 | 4.1~5.6 | 41~56 | 4.8 |
| | FRONT SHOCK JOINT AND FRONT UPPER ARM | M10X1.25 | 4.1~5.6 | 41~56 | 4.8 |
| | FRONT KNUCKLE AND FRONT UPPER ARM | M10X1.25 | 4.1~5.6 | 41~56 | 4.8 |
| | FRONT KNUCKLE AND FRONT LOWER ARM | M10X1.25 | 4.1~5.6 | 41~56 | 4.8 |
| 4 | RR SUSPENSION | | | | |
| | REAR SHOCK UPPER JOINT AND FRAME | M10X1.25 | 4.1~5.6 | 41~56 | 4.8 |
| | REAR UPPER ARM AND FRAME | M10X1.25 | 4.1~5.6 | 41~56 | 4.8 |
| | REAR LOWER ARM AND FRAME | M10X1.25 | 4.1~5.6 | 41~56 | 4.8 |
| | REAR SHOCK JOINT AND REAR LOWER ARM | M10X1.25 | 4.1~5.6 | 41~56 | 4.8 |
| | REAR KNUCKLE AND REAR UPPER ARM | M10X1.25 | 4.1~5.6 | 41~56 | 4.8 |
| | REAR KNUCKLE AND REAR LOWER ARM | M10X1.25 | 4.1~5.6 | 41~56 | 4.8 |

(Cont'd)

1. GENERAL INFORMATION

| NO | ITEM | | TORQUE | | PR-È Kgf·m |
|----|-------------------------------------|----------|---------|---------|---------------|
| | | | Kgf·m | Nm | |
| 5 | BRAKE | | | | |
| | FRONT BRAKE DISC AND FRONT HUB | M6X1.0 | 1.7~2.5 | 17~25 | 2 |
| | REAR BRAKE DISC AND REAR HUB | M8X1.25 | 3.0~4.0 | 30~40 | 3.5 |
| | BRAKE HOSE OIL BOLT | M10X1.25 | 3.0~4.0 | 30~40 | 3.5 |
| | MASTER CYLINDER HOLDER | M6X1.0 | 1.0~1.4 | 10~14 | 1.2 |
| | SECONDARY MASTER CYLINDER AND FRAME | M6X1.0 | 1.0~1.4 | 10~14 | 1.2 |
| | FRONT CALIPER AND KNUCKLE | M8X1.25 | 2.4~3.0 | 24~30 | 2.7 |
| | REAR CALIPER AND BRACKET | M8X1.25 | 2.4~3.0 | 24~30 | 2.7 |
| | MASTER CYLINDER CAP SCREW | M4X0.7 | 0.1~0.2 | 1.0~2.0 | 0.15 |
| | BRAKE CALIPER BLEED VALVE | M8X1.25 | 0.4~0.7 | 4.0~7.0 | 0.55 |
| | BRAKE PEDAL ADJUSTING NUT | M6X1.0 | 1.0~1.4 | 10~14 | 1.2 |
| 6 | FRAME | | | | |
| | EXHAUST PIPE AND HEAD | M8X1.25 | 1.8~2.2 | 18~22 | 2.0 |
| | MUFFLER BRACKET AND FRAME | M10X1.25 | 3.2~3.8 | 32~38 | 3.5 |
| | UPPER ENGINE NUT | M10X1.25 | 5.5~6.5 | 55~65 | 6.0 |
| | FRONT AND REAR LOWER ENGINE NUT | M10X1.25 | 5.5~6.5 | 55~65 | 6.0 |
| | LOWER ENGINE HANGER | M8X1.25 | 2.4~3.0 | 24~30 | 2.7 |
| | SHIFT ROD | M8X1.25 | 2.4~3.0 | 24~30 | 2.7 |
| | FRONT GEARCASE AND FRAME | M10X1.25 | 4.5-6.1 | 45~61 | 5.3 |
| | REAR GEARCASE AND FRAME | M10X1.25 | 4.5-6.1 | 45~61 | 5.3 |
| | THERMO SWITCH ASSY | M16X1.5 | 2.0~2.5 | 20~25 | 2.2 |

* TORQUE (GENERAL)

| ITEM | TORQUE | | ITEM | TORQUE | |
|-------------------|----------|-------|---|-----------|---------|
| | Kgf·m | N·m | | Kgf·m | N·m |
| 5mm bolt and nut | 0.45~0.6 | 4.5~6 | 4 mm screw | 0.05~0.15 | 0.5~1.5 |
| 6mm bolt and nut | 0.8~1.2 | 8~12 | 4 mm screw | 0.2~0.4 | 2~4 |
| 8mm bolt and nut | 1.8~2.5 | 18~25 | 5 mm screw | 0.10~0.3 | 1~3 |
| 10mm bolt and nut | 3.0~4.0 | 30~40 | 5 mm screw | 0.35~0.5 | 3.5~5 |
| 12mm bolt and nut | 5.0~6.0 | 50~60 | 6 mm screw and flange bolt (SH TYPE) | 0.7~1.1 | 7~11 |
| 14mm bolt and nut | 6.0~8.0 | 60~80 | | | |
| | | | 6 mm flange bolt and nut | 1.0~1.4 | 10~14 |
| | | | 8 mm flange bolt and nut | 2.4~3.0 | 24~30 |
| | | | 10 mm flange bolt and nut | 3.5~4.5 | 35~45 |

1. GENERAL INFORMATION

SPECIAL TOOLS

| Tool Name | Tool No. | Illustration (Note: the special tools may differ slightly from those shown in the figure of this manual.) |
|--|------------|--|
| Oil seal and bearing installer | A120E00014 |  |
| Valve adjuster (Refer to the “VALVE CLEARANCE” section in the chapter 3.) | A120E00036 |  |
| Bearing puller | A120E00037 |  |
| Valve spring compressor (Refer to the “CYLINDER HEAD DISASSEMBLY/INSPECTION/ASSEMBLY” section in the chapter 8.) | A120E00040 |  |
| Universal holder (Refer to the “DRIVE PULLEY, DRIVE V-BELT AND DRIVEN PULLEYREMOVAL/INSPECTION/INSTALLATION” section and “CLUTCH REMOVAL/INSTALLATION” section in the chapter 10.) | A120E00056 |  |
| Drive pulley holder (Refer to the “DRIVE PULLEY, DRIVE V-BELT AND DRIVEN PULLEYREMOVAL/INSPECTION/INSTALLATION” section in the chapter 10.) | A120E00058 |  |

(Cont'd)

1. GENERAL INFORMATION

| Tool Name | Tool No. | Illustration (Note: the special tools may differ slightly from those shown in the figure of this manual.) |
|---|------------|--|
| <p>Driven pulley holder</p> <p>(Refer to the “DRIVEN PULLEY DISASSEMBLY/INSPECTION/ASSEMBLY” section in the chapter 10.)</p> | A120E00059 |  |
| <p>Flywheel puller</p> <p>(Refer to the “STARTER CLUTCH REMOVAL/INSPECTION/INSTALLATION” section in the chapter 19.)</p> | A120E00060 |  |
| <p>Oil filter cartridge wrench</p> <p>(Refer to the “(Refer to the “ENGINE OIL” section in the chapter 3.)</p> | A120E00061 |  |
| <p>Output shaft bearing nut wrench</p> <p>(Refer to the “(Refer to the “BEARING REPLACEMENT IN THE RIGHT CRANKCASE” section in the chapter 11.)</p> | A120E00066 |  |
| | | |





(Cont'd)

1. GENERAL INFORMATION

| Tool Name | Tool No. | Illustration (Note: the special tools may differ slightly from those shown in the figure of this manual.) |
|---|------------|--|
| Crankshaft bearing puller | A120E00068 |  |
| Ball joint remover (Refer to the “STEERING KNUCKLE REMOVAL/ INSPECTION/ INSTALLATION” section in the chapter 15) | A120F00012 |  |
| Left pivot lock nut wrench (Refer to the “REAR SWING ARM REMOVAL/ INSTALLATION” section in the chapter 15) | A120F00013 |  |
| Joint yoke puller (Refer to the “FRONT DRIVE DISASSEMBLY/INSPECTION/ ASSEMBLY” section in the chapter 13) | A120F00016 |  |
| Drive shaft puller (Refer to the “FRONT DRIVE SHAFT REOMVAL/ INSPECTION/ INSTALLATION” section in the chapter 13) | A120F00017 |  |
| Yoke bearing puller (Refer to the “FRONT DRIVE DISASSEMBLY/INSPECTION/ ASSEMBLY” section in the chapter 13) | A120F00018 |  |

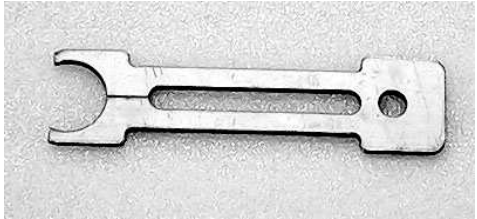
(Cont'd)

1. GENERAL INFORMATION

| Tool Name | | | Tool No. | Illustration (Note: the special tools may differ slightly from those shown in the figure of this manual.) |
|--|------|--------|--|---|
| Pinion bearing lock nut wrench (Refer to the “ REAR DRIVE DISASSEMBLY/INSPECTION / ASSEMBLY ” section in the chapter 13.) | | | A120F00020 |  |
| Pinion puller (Refer to the “ REAR DRIVE DISASSEMBLY/INSPECTION / ASSEMBLY ” section in the chapter 13.) | | | A120F00021 |  |
| C-ring remover (Refer to the “ FRONT DRIVE DISASSEMBLY/INSPECTION / ASSEMBLY ” section in the chapter 13) | | | A120F00022 |  |
| Carburetor adjustment Adjust pilot screw position | | | A120E00076 |  |
| F025 | A120 | F00025 | FRONT ASSY GEAR CASE COLLAR LOCK M54*15 WRENCH |  MXU 400 /UXV 500/MXU 500 IRS |
| F026 | A120 | F00026 | REAR ASSY GEAR CASE PINION GEAR PULLER |  UXV 500/MXU 500 IRS |
| F027 | A120 | F00027 | BEARING PULLER |  ATV /UXV 500 MODEL |

1. GENERAL INFORMATION

LUBRICATION POINTS

ENGINE

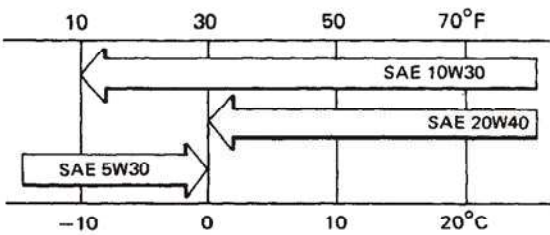
| Lubrication Points | Lubricant |
|---|--|
| Valve guide/valve stem movable part Camshaft protruding surface Valve rocker arm friction surface Camshaft drive chain Cylinder lock bolt Piston surroundings and piston ring grooves Piston pin surroundings Cylinder inside wall Connecting rod/piston pin hole Connecting rod big end Clutch Crankshaft Balance shaft Crankshaft one-way clutch movable part Recoil starter pulley Oil pump drive chain Starter reduction gear Starter one-way clutch O-ring face Oil seal lip Output shaft Bevel gear Drive shaft Countershaft Main shaft Transmission gear shaft bearing part | <ul style="list-style-type: none"> ●Genuine KYMCO Engine Oil ●API SJ Engine Oil  |
| Front drive gear and bearing part | Gear oil: SAE 80# |
| Rear drive gear and bearing part | Gear oil: SAE 80# |

2. FRAME COVERS/EXHAUST MUFFLER

2. FRAME COVERS/EXHAUST MUFFLER

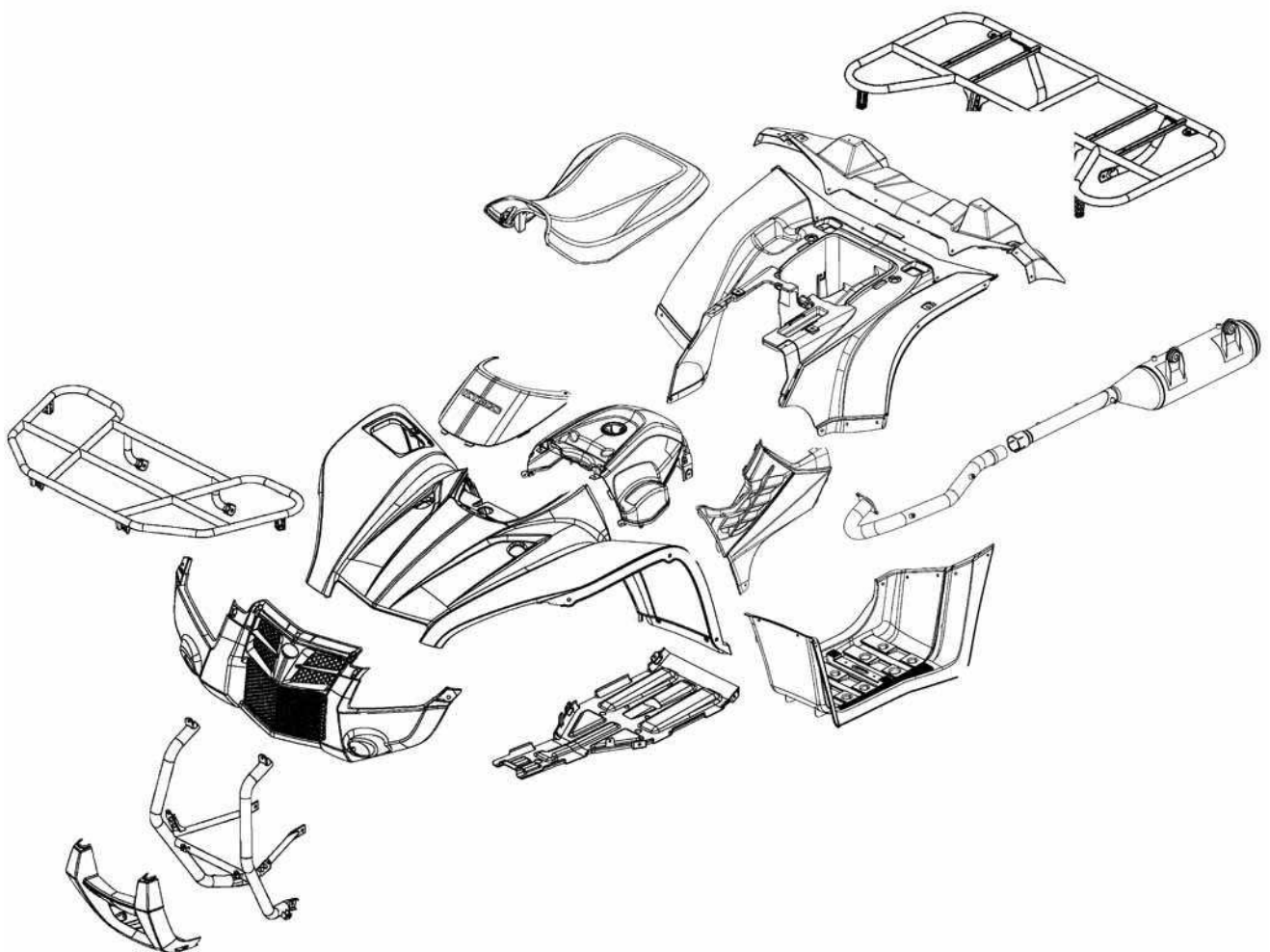

2. FRAME COVERS/EXHAUST MUFFLER

2. FRAME COVERS/EXHAUST MUFFLER

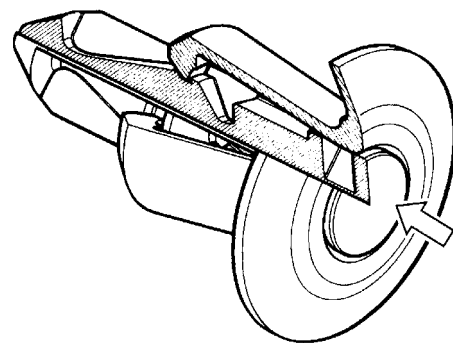
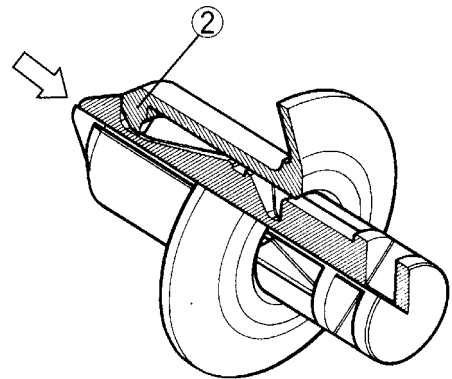
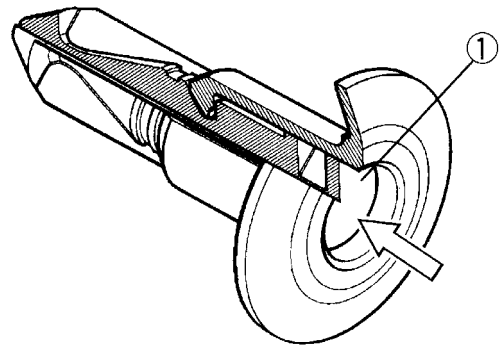

2. FRAME COVERS/EXHAUST MUFFLER

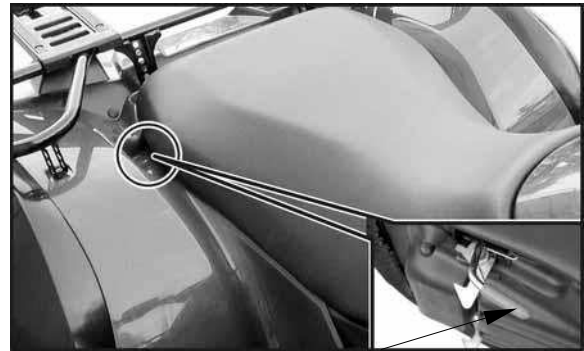

Lever

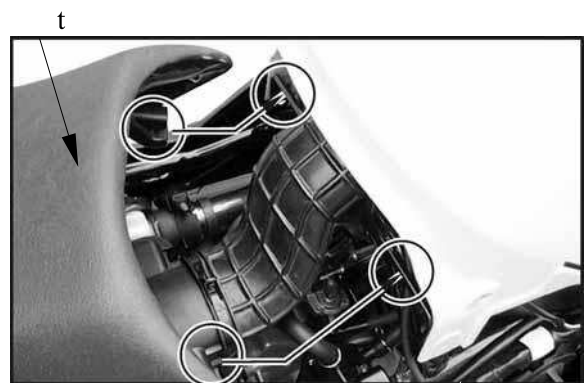

Front Cargo Rack



2. FRAME COVERS/EXHAUST MUFFLER

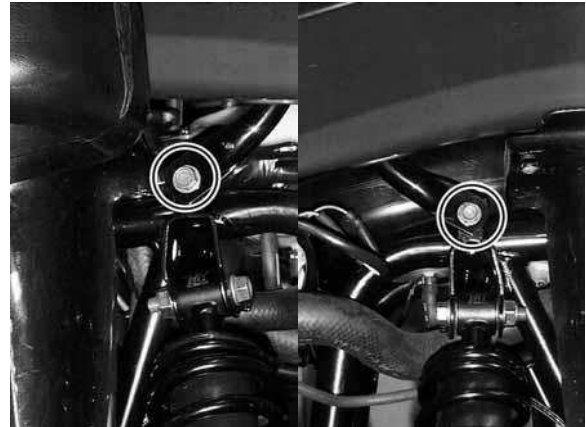

2. FRAME COVERS/EXHAUST MUFFLER

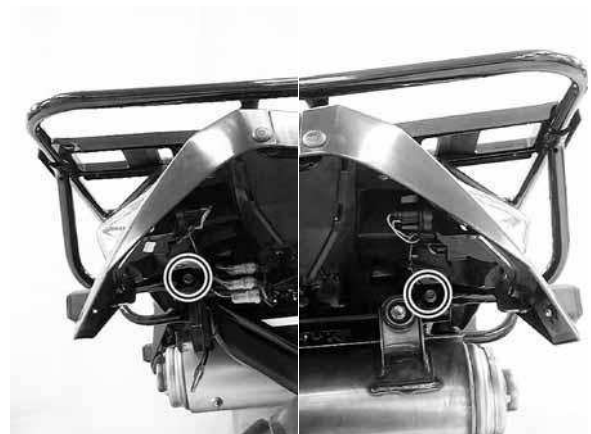

2. FRAME COVERS/EXHAUST MUFFLER

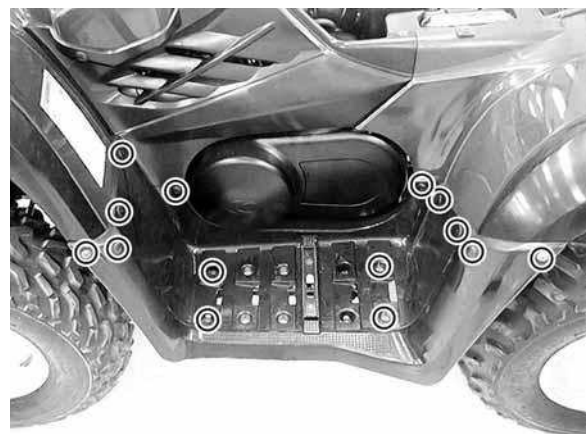
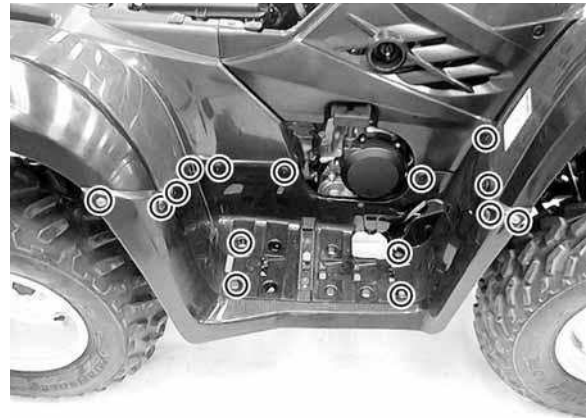
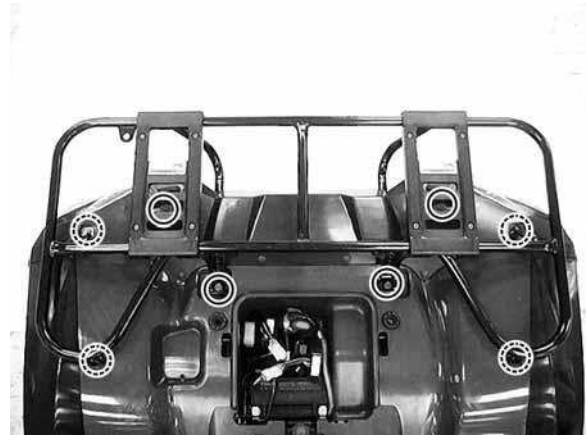

2. FRAME COVERS/EXHAUST MUFFLER

During removal, do not pull the joint claws forcedly to avoid damage.



During removal, do not pull the joint claws forcedly to avoid damage.



2. FRAME COVERS/EXHAUST MUFFLER

Instrument Connector Accessory Socket

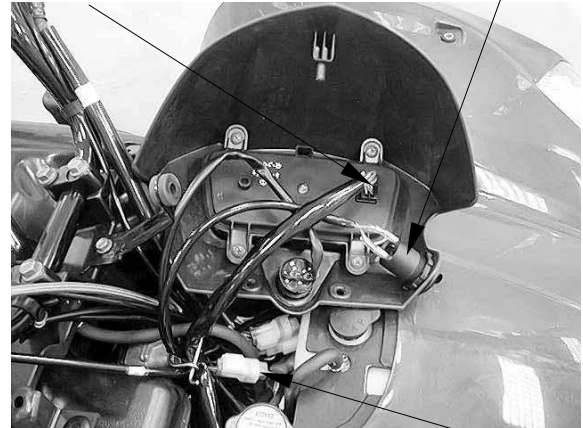

r

Drive Select Grip

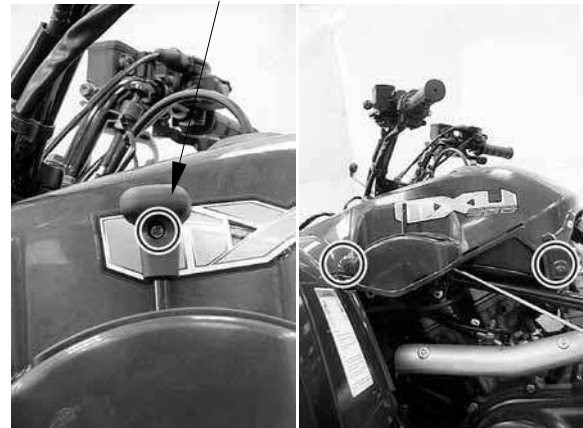

Fuel Tank Cap/Seal



Put on the fuel tank cap after removing the cover to prevent duct, mud, etc. from entering the fuel tank

2. FRAME COVERS/EXHAUST MUFFLER

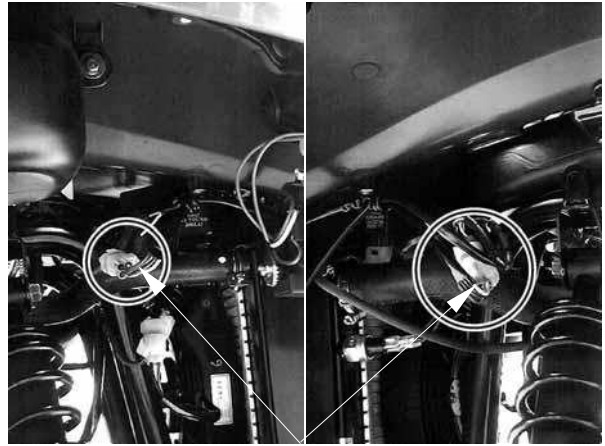

Turn Signal Lights/Headlights Connectors.

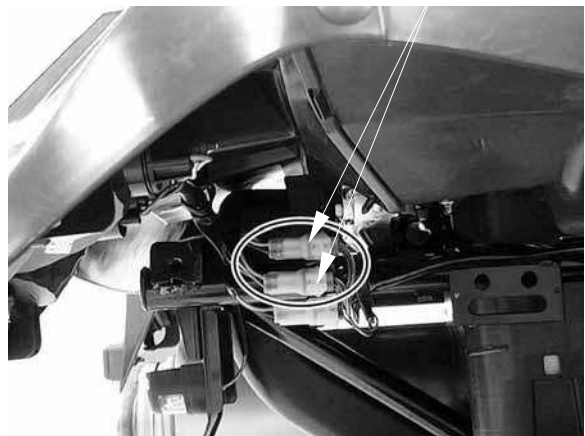
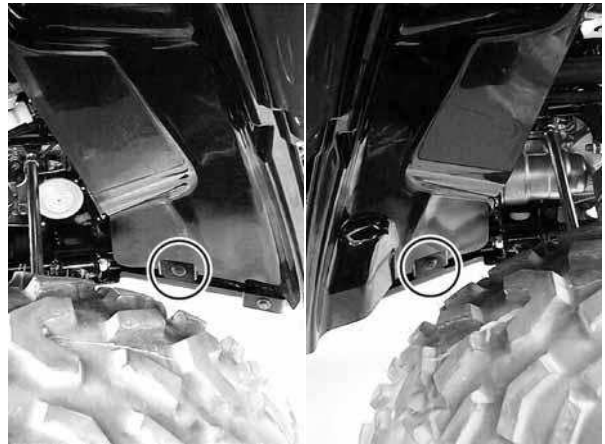

2. FRAME COVERS/EXHAUST MUFFLER

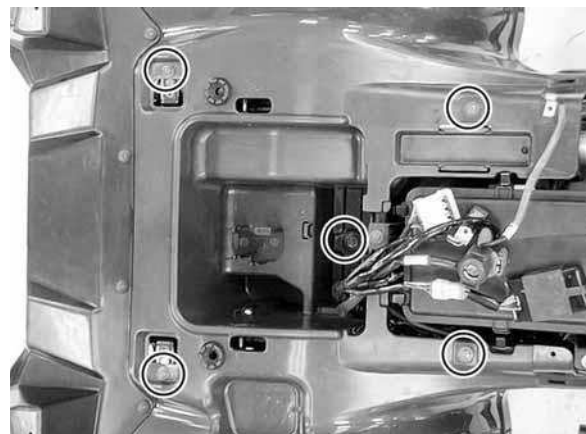
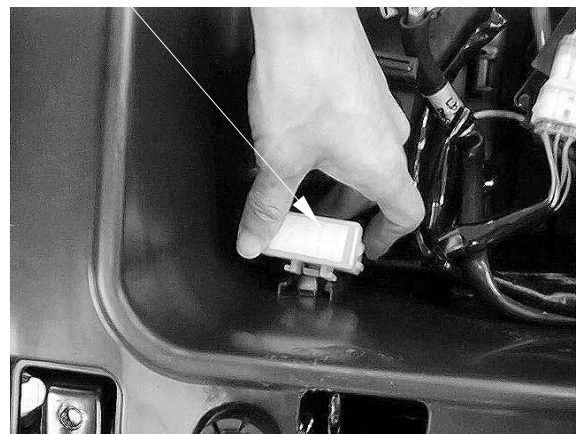
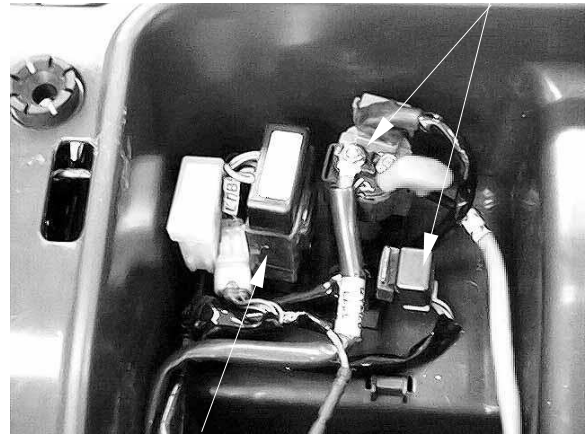

2. FRAME COVERS/EXHAUST MUFFLER

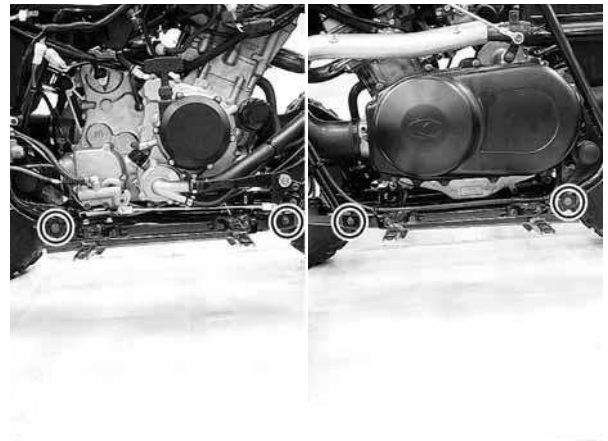
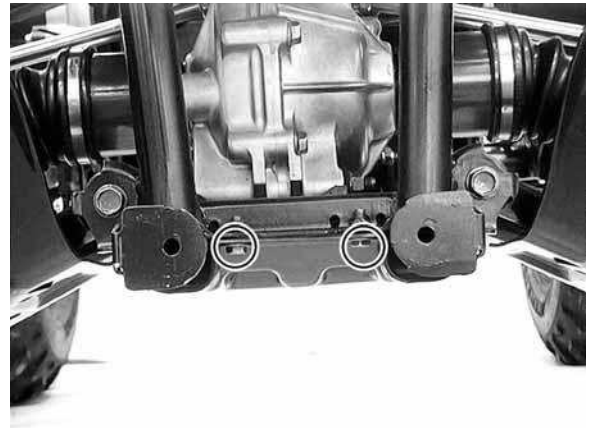

2. FRAME COVERS/EXHAUST MUFFLER

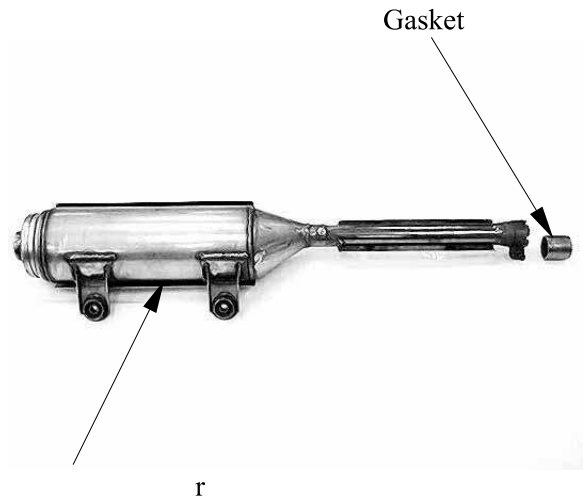
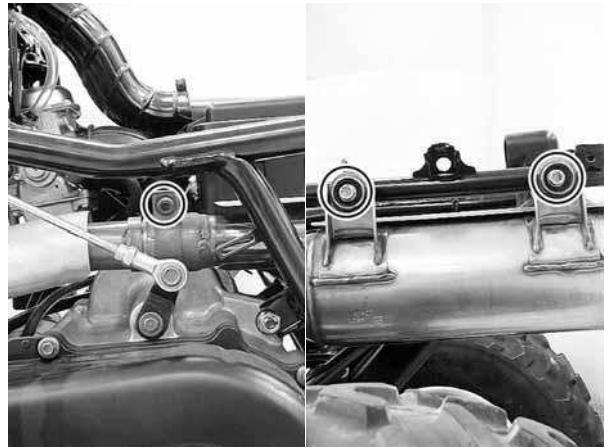

2. FRAME COVERS/EXHAUST MUFFLER

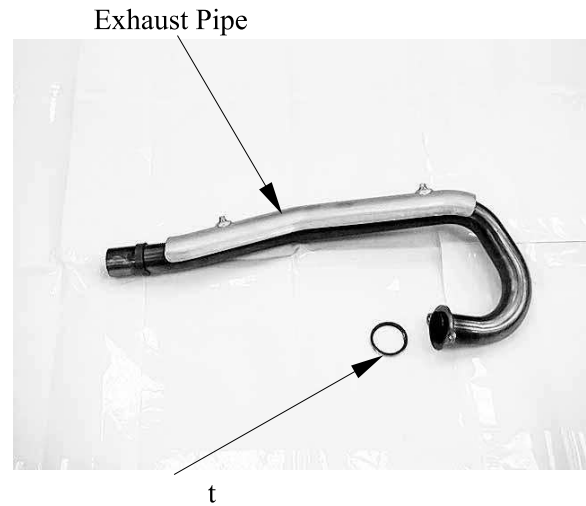

Be sure to install a new exhaust gasket.

3. INSPECTION/ADJUSTMENT

3. INSPECTION/ADJUSTMENT

3. INSPECTION/ADJUSTMENT

| | |
|---------------------|---------------------|
| Tie-rod lock nut | 2..5 kgf-m (25 N-m) |
| Front wheel hub nut | 5.5kgf-m (70 N-m) |
| Rear wheel hub nut | 5.5kgf-m (100 N-m) |

SPECIAL TOOLS

| | |
|------------------------|------------|
| Valve adjusting wrench | A120E00036 |
| Oil cartridge wrench | A120E00061 |

3. INSPECTION/ADJUSTMENT

| ITEM | WHICHEVER COMES FIRST ROUTINE | INITIAL | | | EVERY | | |
|--|--|---------|-----------------------|-----------------------|-----------------------|--|--|
| | | mi | 100 | 600 | 1200 | | |
| | | Km | 150 | 1000 | 2000 | | |
| | | MONTH | 1 | 6 | 12 | | |
| Engine oil | •Replace (Warm engine before draining). | | <input type="radio"/> | <input type="radio"/> | <input type="radio"/> | | |
| Oil strainer | •Clean. •Replace if necessary. | | <input type="radio"/> | <input type="radio"/> | <input type="radio"/> | | |
| Engine oil filter cartridge | •Replace | | <input type="radio"/> | <input type="radio"/> | <input type="radio"/> | | |
| Front drive gear oil | •Check oil level/oil leakage •Replace every 12 months. | | <input type="radio"/> | | <input type="radio"/> | | |
| Rear drive gear oil | •Check oil level/oil leakage •Replace every 12 months. | | <input type="radio"/> | | <input type="radio"/> | | |
| Air filter element (for engine and *V-belt compartment) | •Clean. (More often in wet or dusty areas.) •Replace if necessary. | | | <input type="radio"/> | <input type="radio"/> | | |
| Carburetor | •Check idle speed/starter operation. •Adjust if necessary. | | <input type="radio"/> | <input type="radio"/> | <input type="radio"/> | | |
| Cylinder head cover breather system | •Check breather hose for cracks or damage. •Replace if necessary. | | | <input type="radio"/> | <input type="radio"/> | | |
| Spark plug | •Check condition. •Adjust gap and clean. •Replace if necessary. | | <input type="radio"/> | <input type="radio"/> | <input type="radio"/> | | |
| Fuel line | •Check fuel hose for cracks or damage. •Replace if necessary. | | | <input type="radio"/> | <input type="radio"/> | | |
| Valves | •Check valve clearance. •Adjust if necessary. | | <input type="radio"/> | <input type="radio"/> | <input type="radio"/> | | |
| Brake | •Check operation and brake fluid. •Replace brake pad if necessary. | | <input type="radio"/> | <input type="radio"/> | <input type="radio"/> | | |
| Coolant | •Check coolant leakage. •Replace if necessary. •Replace coolant every 24 months. | | <input type="radio"/> | <input type="radio"/> | <input type="radio"/> | | |
| V-belt | •Check operation. •Replace if damage or excessive wear. | | <input type="radio"/> | | <input type="radio"/> | | |
| Exhaust system | •Check leakage. •Retighten if necessary. •Replace gasket if necessary. | | | <input type="radio"/> | <input type="radio"/> | | |
| Spark arrester | •Clean | | | <input type="radio"/> | <input type="radio"/> | | |
| Wheels | •Check balance/damage/runout. •Replace if necessary. | | <input type="radio"/> | <input type="radio"/> | <input type="radio"/> | | |
| Wheel bearings | •Check bearing assembly for looseness/damage. •Replace if damaged. | | <input type="radio"/> | <input type="radio"/> | <input type="radio"/> | | |
| Steering system | •Check operation. •Replace if damaged. •Check toe-in. •Adjust if necessary. | | <input type="radio"/> | <input type="radio"/> | <input type="radio"/> | | |
| Drive shaft boots | •Check operation. •Replace if damaged. | | | <input type="radio"/> | <input type="radio"/> | | |
| Suspension | •Check operation. •Correct if necessary. | | | <input type="radio"/> | <input type="radio"/> | | |
| Knuckle shafts/ Steering shaft | •Lubricate every 6 months. | | | <input type="radio"/> | <input type="radio"/> | | |
| Fittings and Fasteners | •Check all chassis fittings and fasteners. •Correct if necessary. | | <input type="radio"/> | <input type="radio"/> | <input type="radio"/> | | |

3. INSPECTION/ADJUSTMENT

* Do not smoke or allow flames or sparks in your working area.

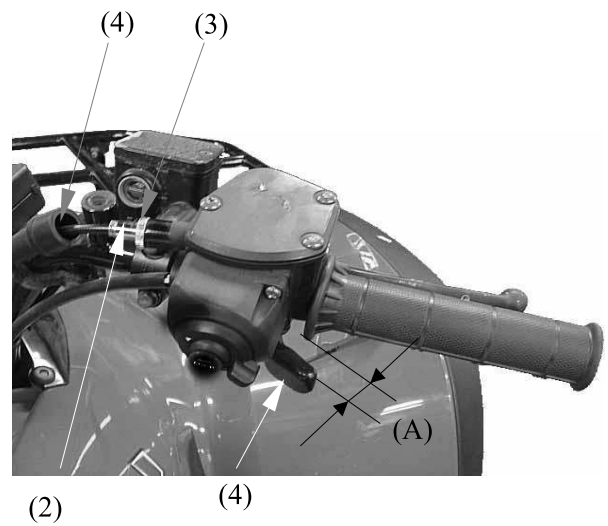
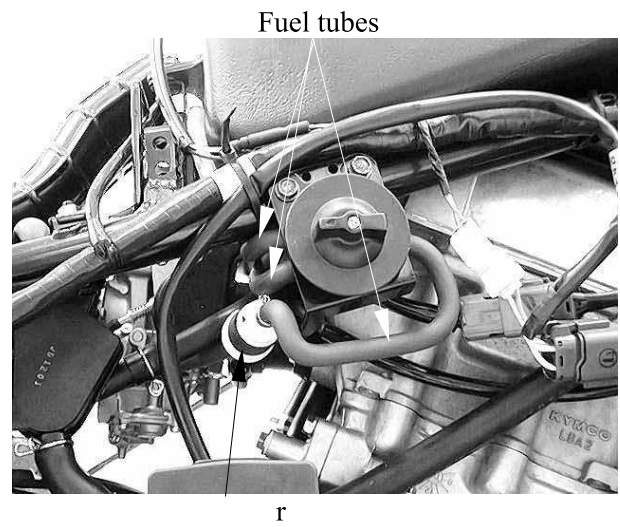

3. INSPECTION/ADJUSTMENT

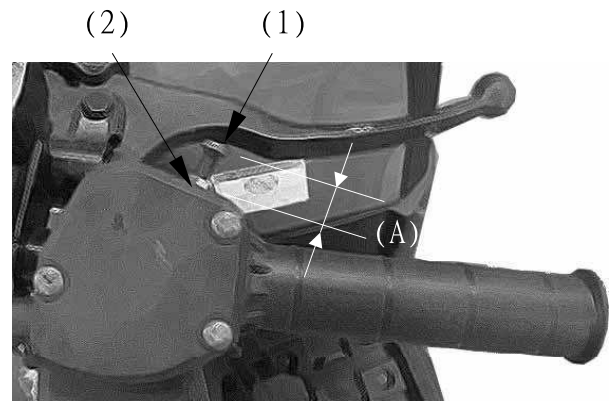

|  WARNING |
|---|
| <p>POTENTIAL HAZARD Improper adjustment of the speed limiter and throttle.</p> |
| <p>WHAT CAN HAPPEN The throttle cable could be damaged. Improper throttle operation could result. You could lose control, have an accident or be injured.</p> |
| <p>HOW TO AVOID THE HAZARD Do not turn the speed adjuster out more than 13 mm (0.52 in). Always make sure the throttle lever free play is adjusted to 1.0~4.0 mm (0.04~0.16 in).</p> |

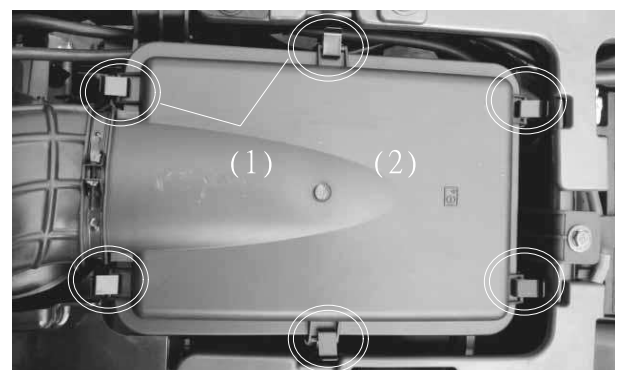

3. INSPECTION/ADJUSTMENT

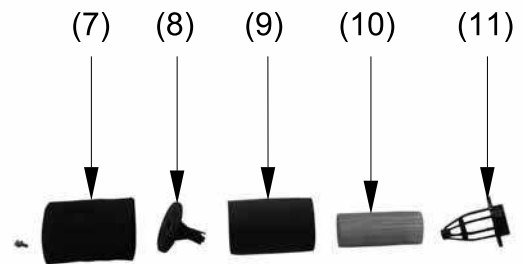
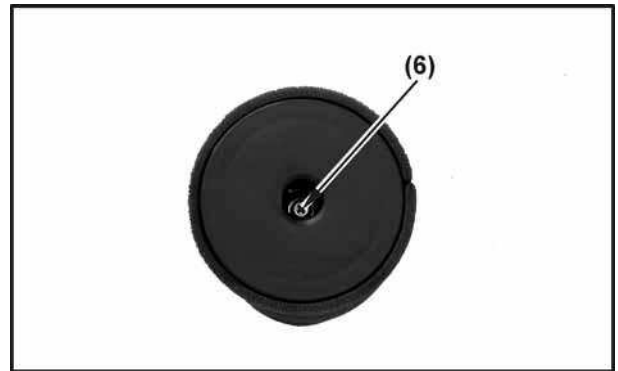

* Use parts cleaning solvent only. Never use gasoline or low flash point solvents which may lead to a fire or explosion.

* Do not twist or wring out the foam element. This could damage the foam material.

* The element should be wet but not dripping.

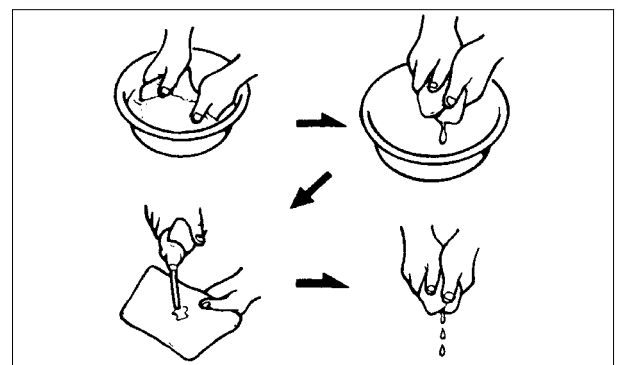

3. INSPECTION/ADJUSTMENT

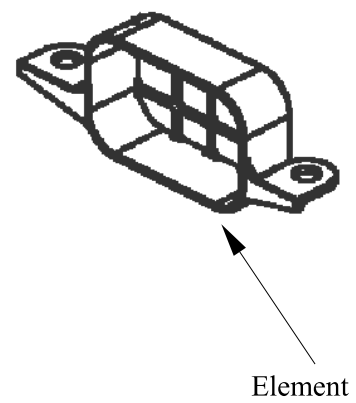
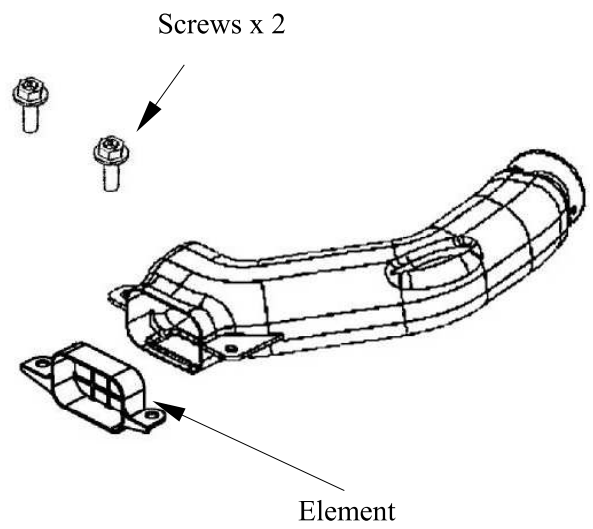
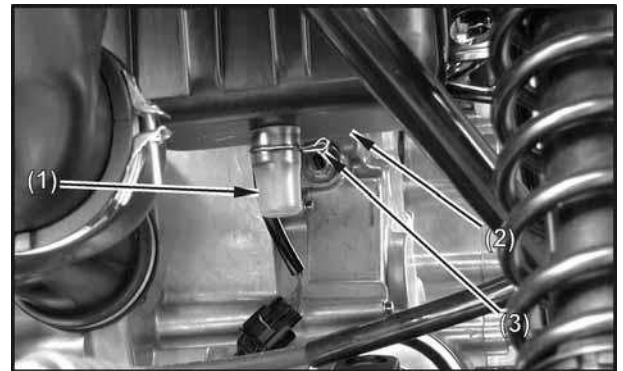

3. INSPECTION/ADJUSTMENT

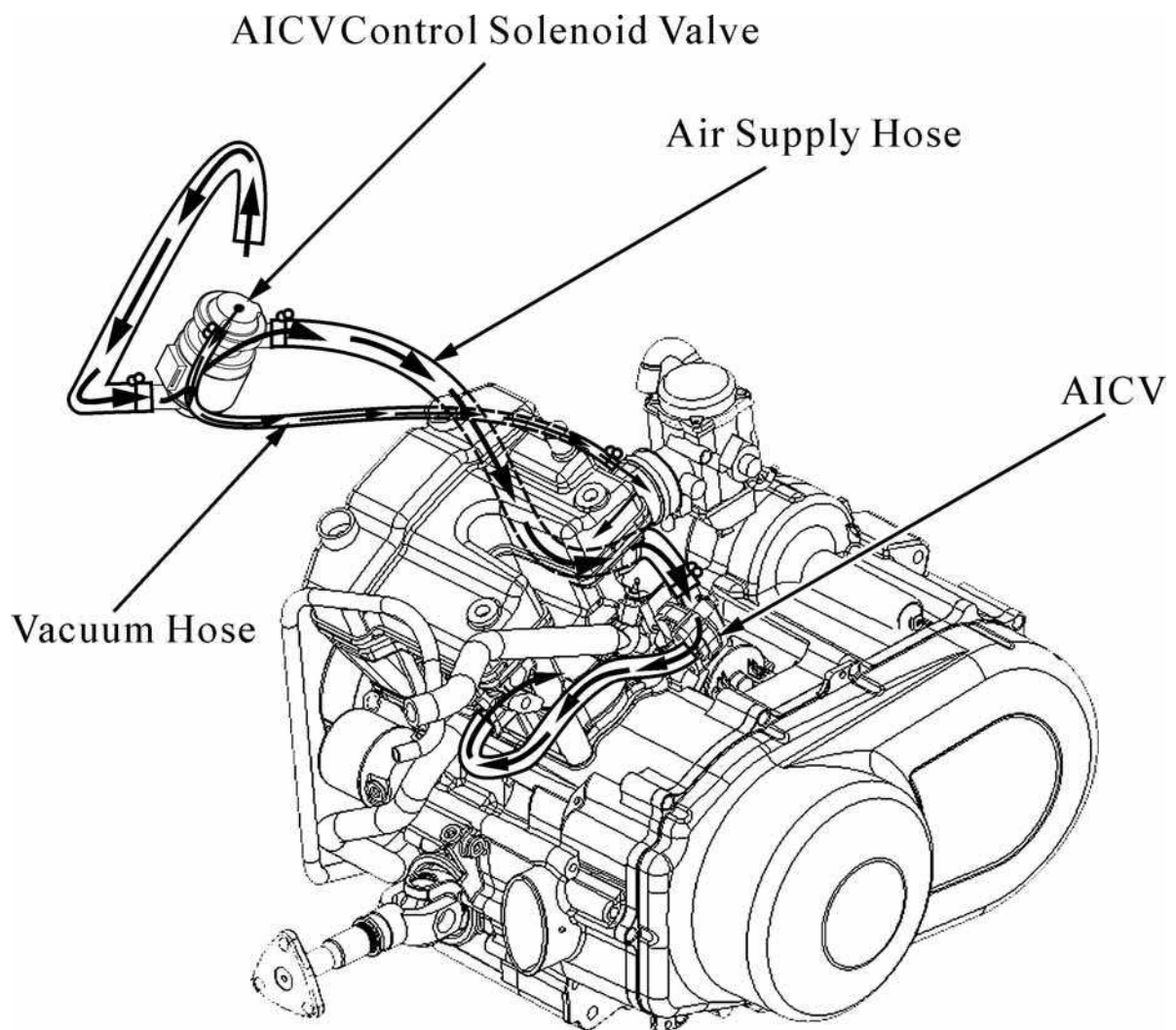

3. INSPECTION/ADJUSTMENT

*

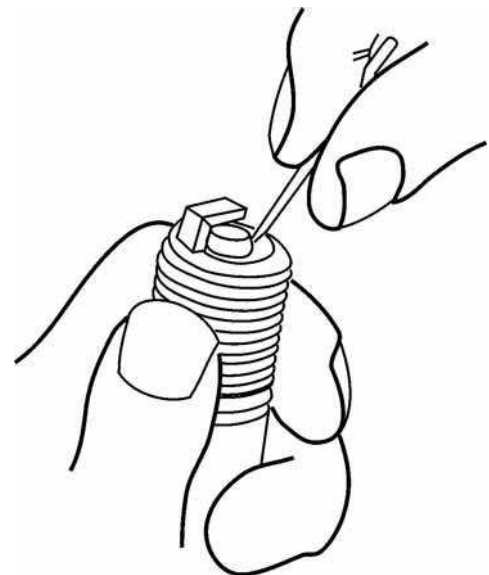
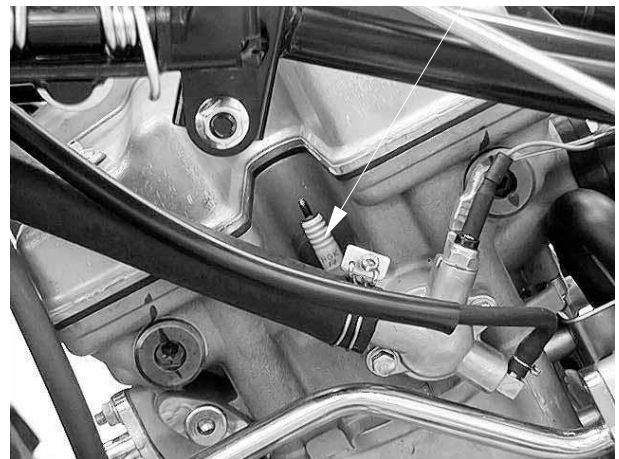

3. INSPECTION/ADJUSTMENT

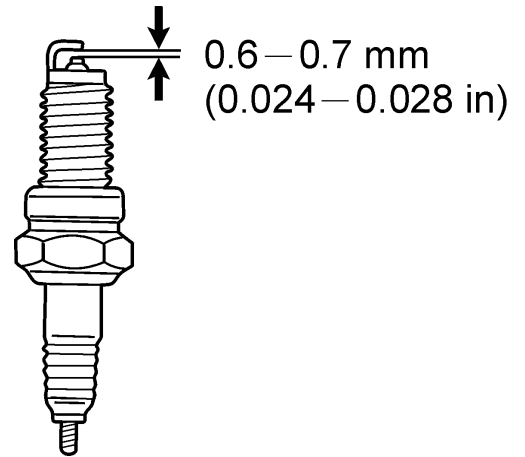

3. INSPECTION/ADJUSTMENT

*

Timing Hole Cap/O-ring

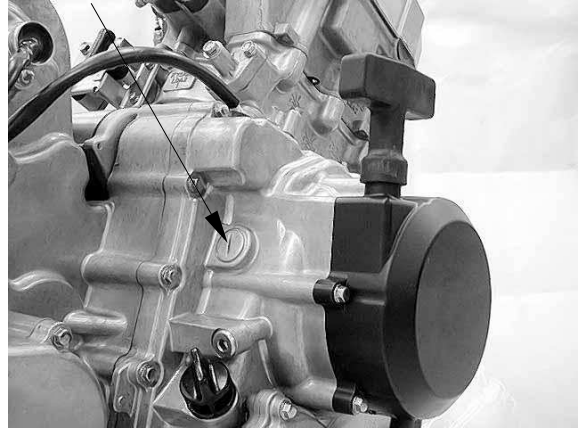

Index Mark

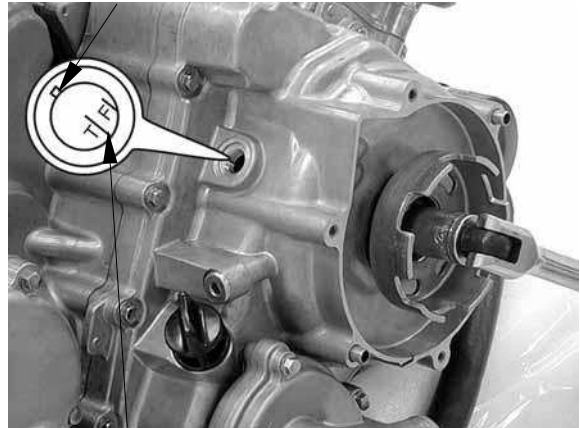

"T" Mark

Punch Marks



3. INSPECTION/ADJUSTMENT

Wrench Thickness Gauge Valve Adjusting

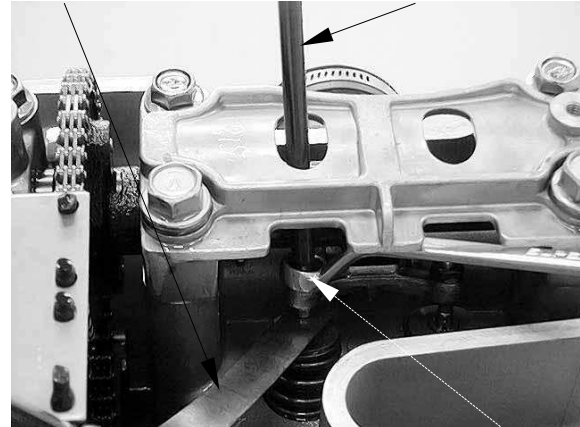

Lock Nut

* The engine must be warm for accurate idle speed inspection and adjustment.

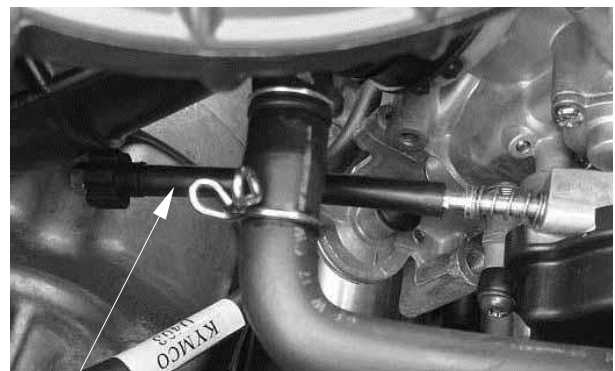

Throttle Stop Screw

3. INSPECTION/ADJUSTMENT

Compression Gauge

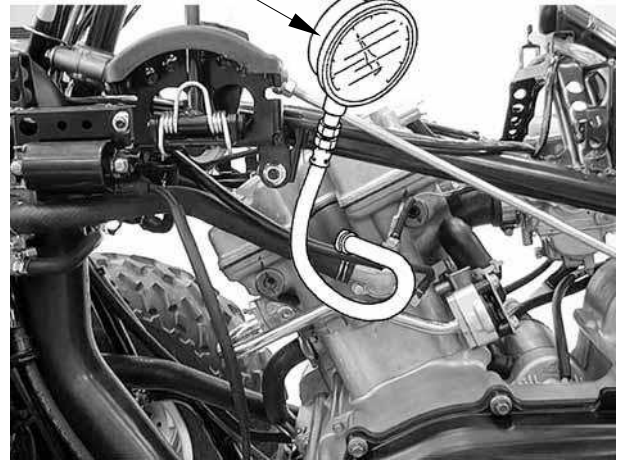

Upper Level

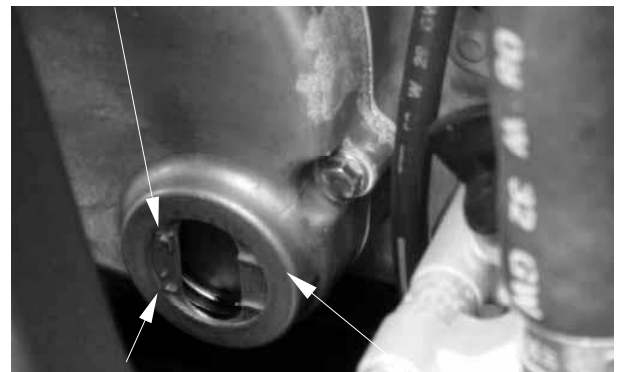

Lower Level

Inspection Window

* Run the engine for 2~3 minutes and check the oil level after the engine is stopped for 2~3 minutes.

* Other viscosities shown in the chart may be used when the average temperature in your riding area is within the indicated range.

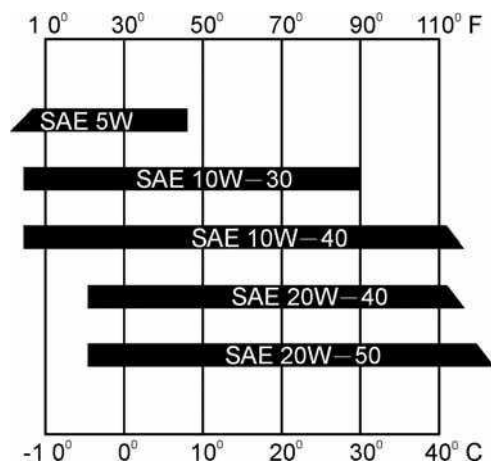

3. INSPECTION/ADJUSTMENT

* Be sure no foreign material enters the crankcase.

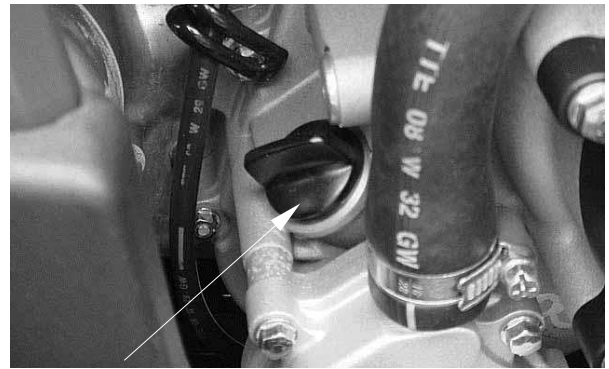

(1)

* The engine oil will drain more easily while the engine is warm.

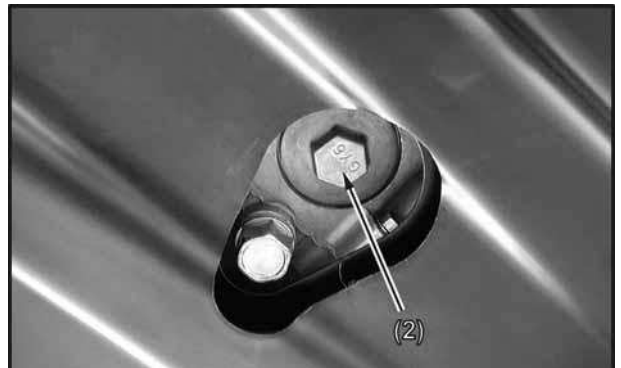

r

Oil Filter Cap

3. INSPECTION/ADJUSTMENT

*

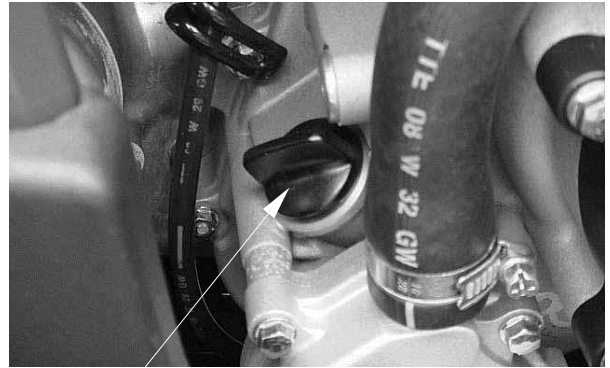

(1)

* The engine oil will drain more easily while the engine is warm.



* Skip steps 6 to 10 if the oil filter cartridge is not being replaced.

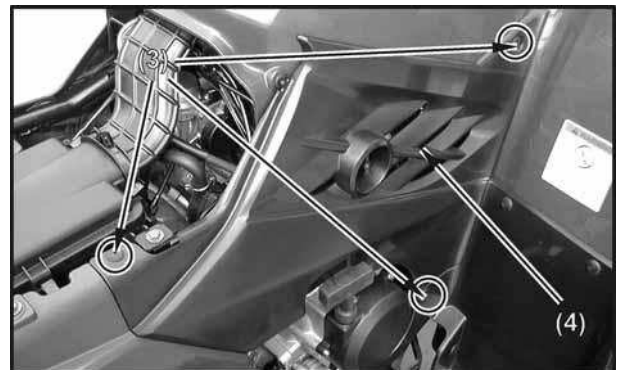

3. INSPECTION/ADJUSTMENT

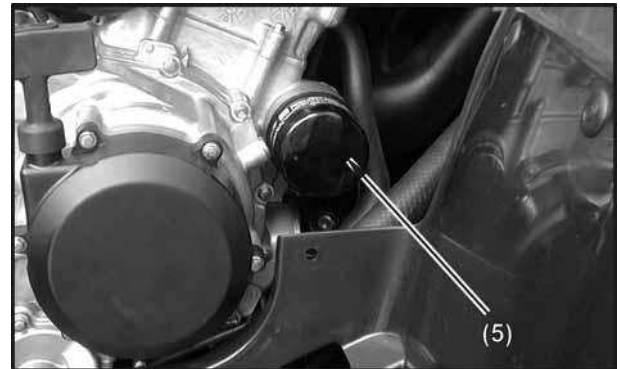

*

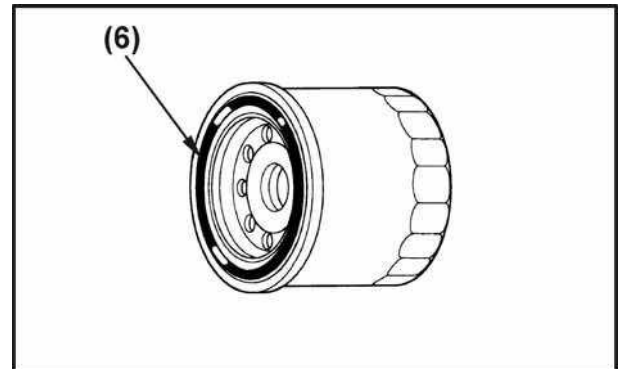

* Be sure no foreign material enters the crankcase.

3. INSPECTION/ADJUSTMENT

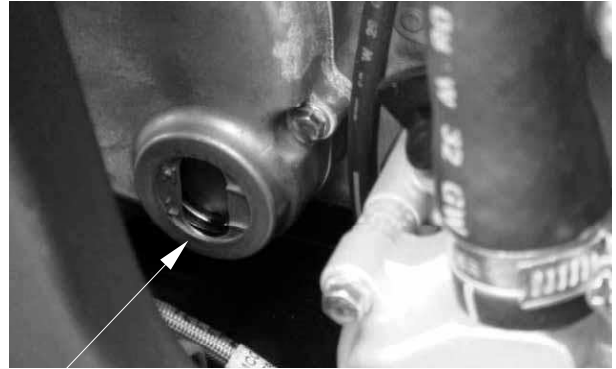

(7)

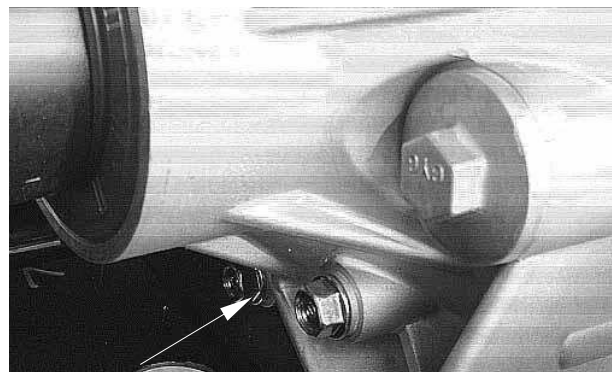

(4)

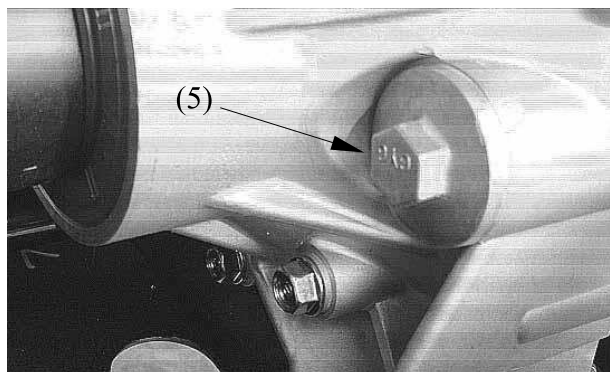

(5)

3. INSPECTION/ADJUSTMENT

* Be sure no foreign material enters the crankcase.

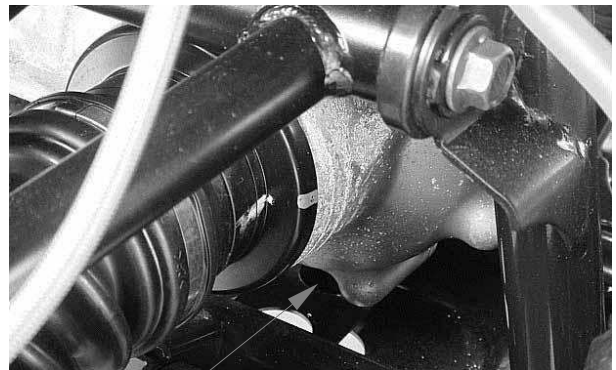

(1)

(2)



3. INSPECTION/ADJUSTMENT



(3)

* Be sure no foreign material enters the crankcase.

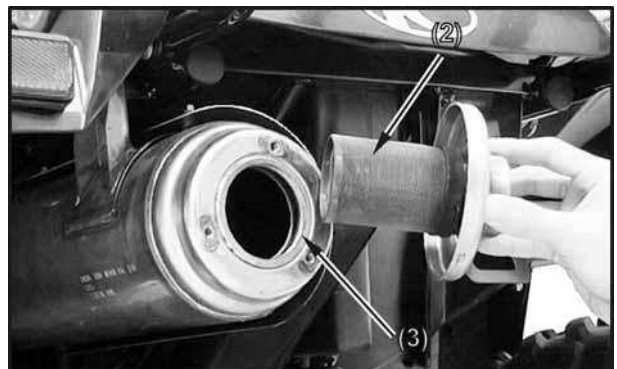
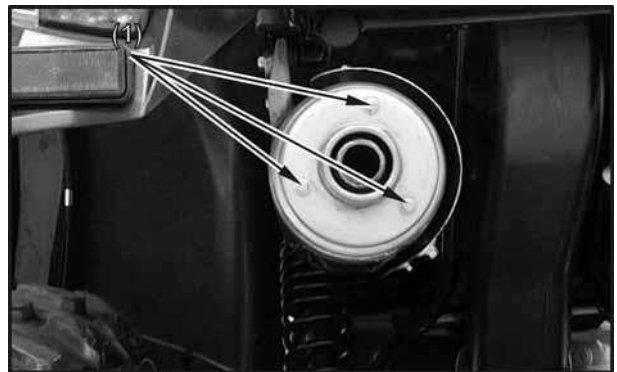

3. INSPECTION/ADJUSTMENT

⚠ WARNING

POTENTIAL HAZARD

Improper cleaning of the spark arrester.
Hot exhaust system.

WHAT CAN HAPPEN

Could injure the eyes.
Could cause burns.
Could cause carbon monoxide poisoning,
possibly leading to death.
Could start a fire

HOW TO AVOID THE HAZARD

When cleaning the spark arrester:
Always let the exhaust system cool prior to
touching exhaust components
Do not start the engine when cleaning the
exhaust system.

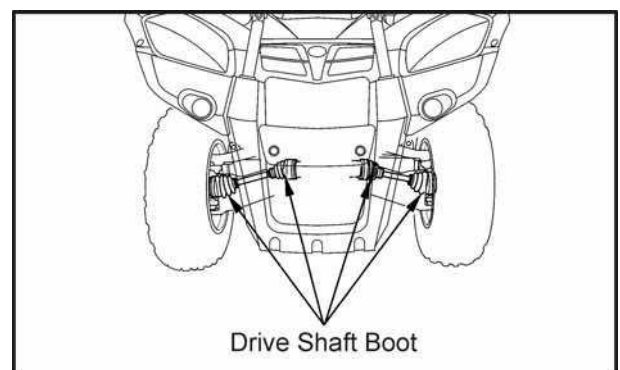
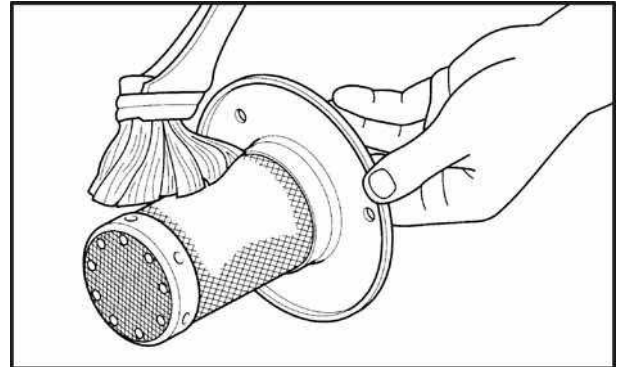

3. INSPECTION/ADJUSTMENT

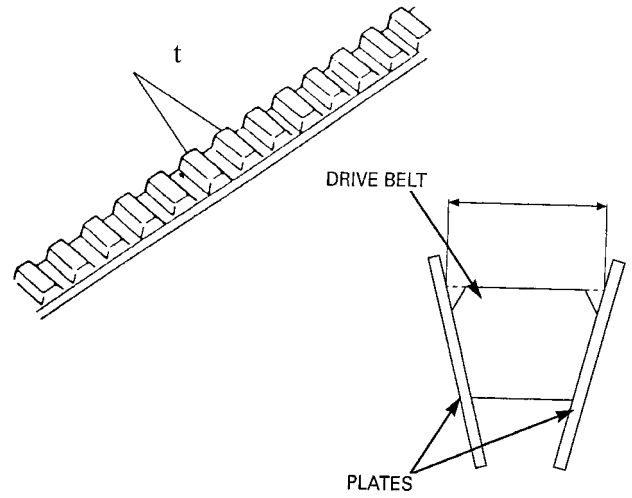

3. INSPECTION/ADJUSTMENT

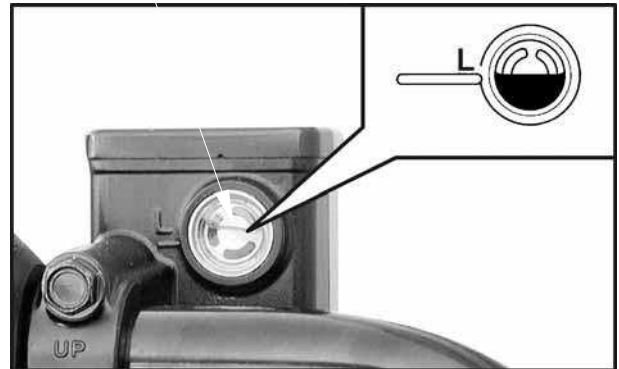

Inspection Window (Rear Brake Pedal)

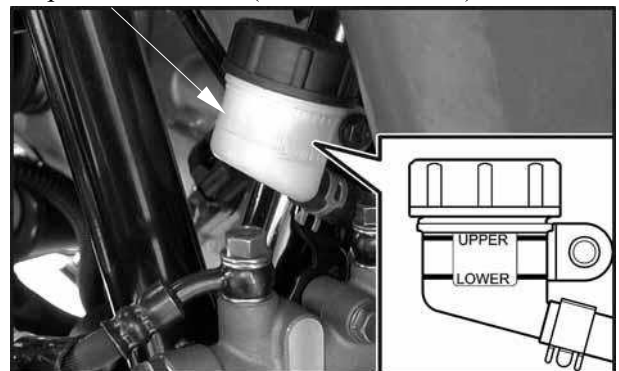

Adjust Screws

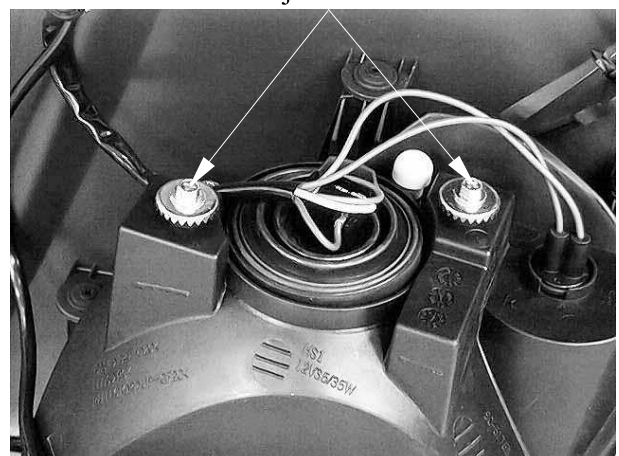

3. INSPECTION/ADJUSTMENT

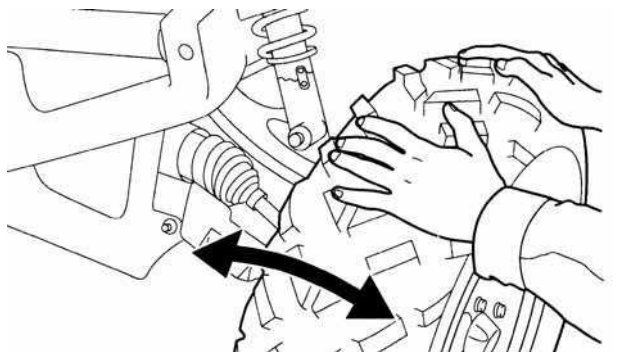
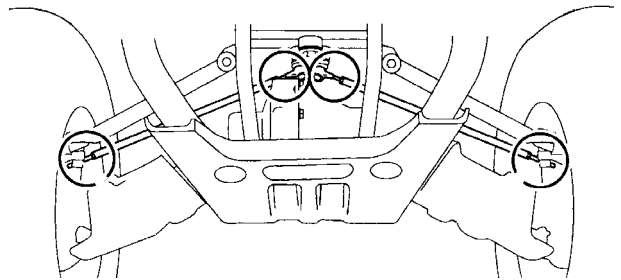
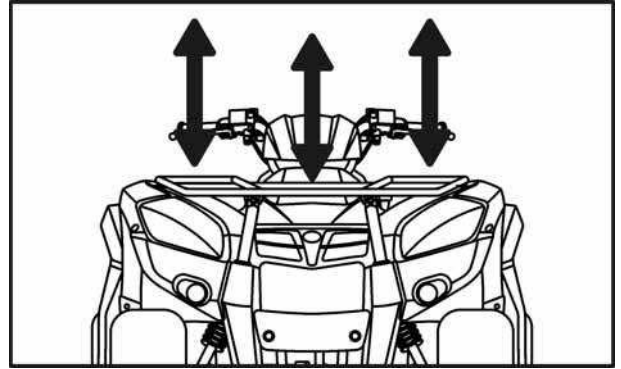

3. INSPECTION/ADJUSTMENT

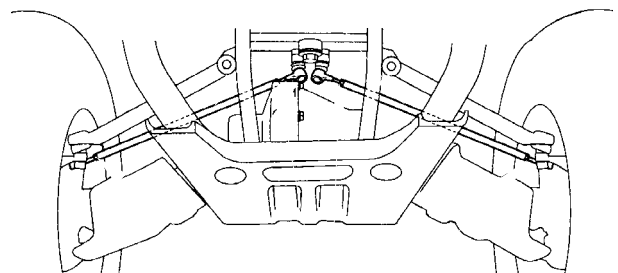
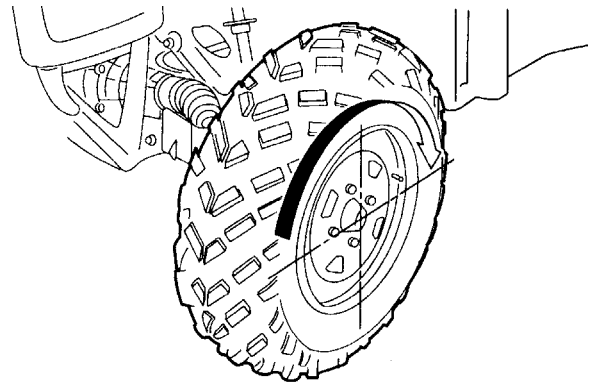
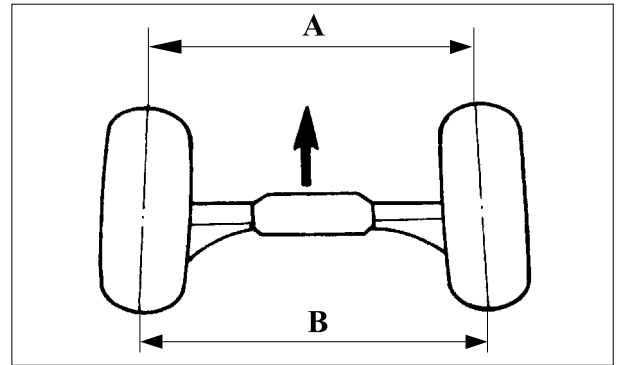

*

3. INSPECTION/ADJUSTMENT

* The threads on both rod-end must be of the same length.

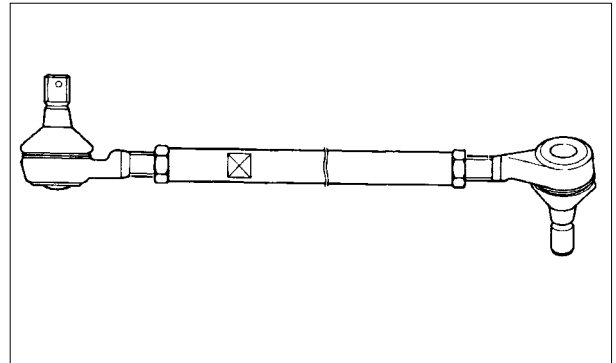

* Tire pressure should be checked when tires are cold.

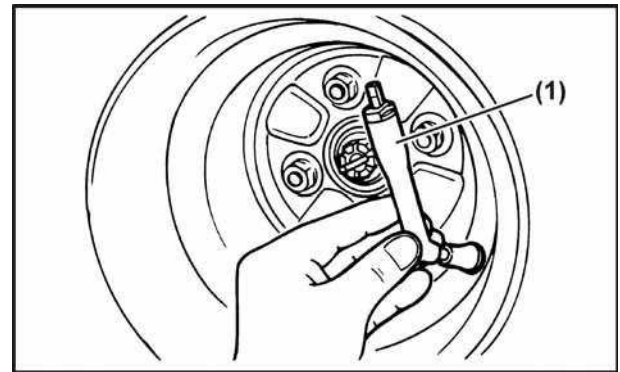

t



3. INSPECTION/ADJUSTMENT



Rear Axle Nut

* It is dangerous to ride with a worn out tire. When a tire wear is out of specification, replace the tire immediately.

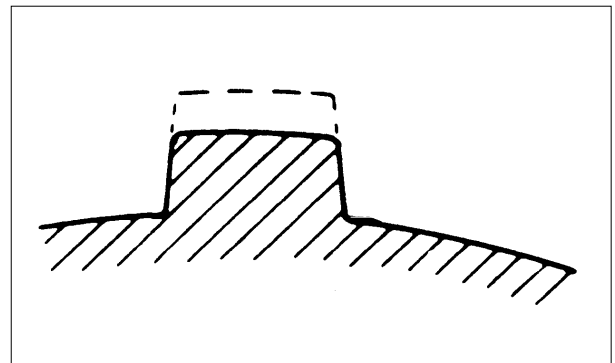

*

- Never attempt even small repairs to the wheel.
- Ride conservatively after installing a tire to allow it to seat itself properly on the rim.

3. INSPECTION/ADJUSTMENT

*

spring preload to the same setting.
Uneven adjustment can cause poor handling and loss of stability.

r

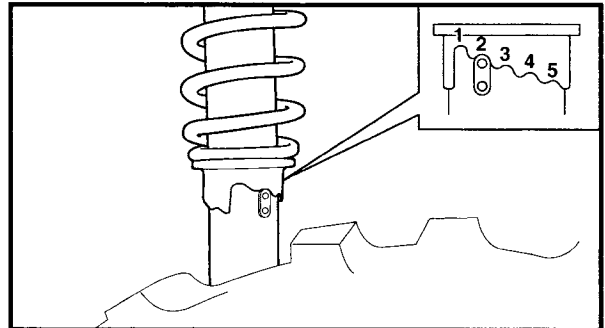

*

spring preload to the same setting.
Uneven adjustment can cause poor handling and loss of stability.

r

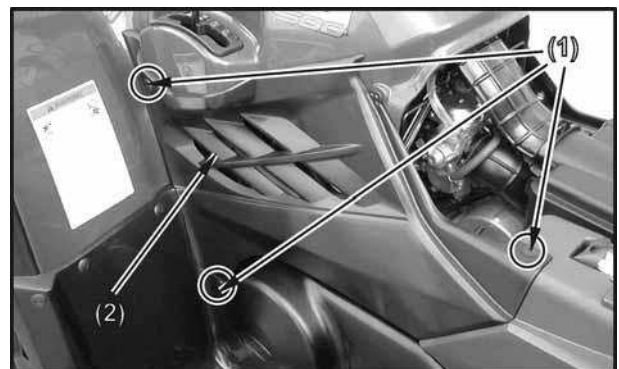
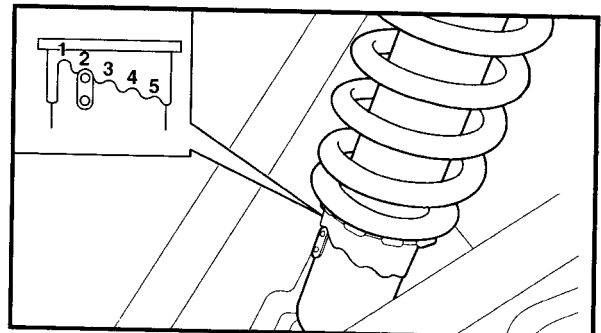

3. INSPECTION/ADJUSTMENT

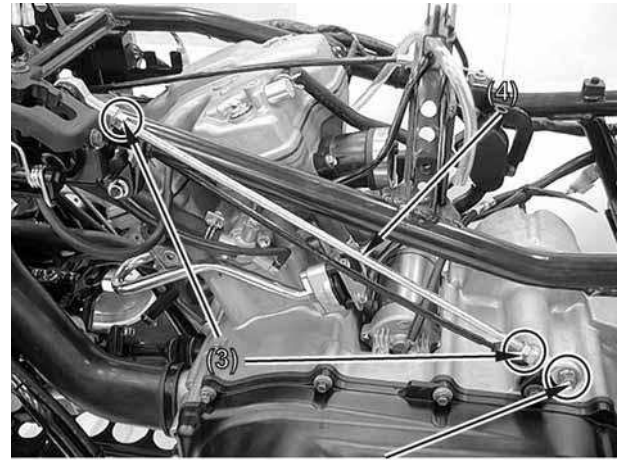

t

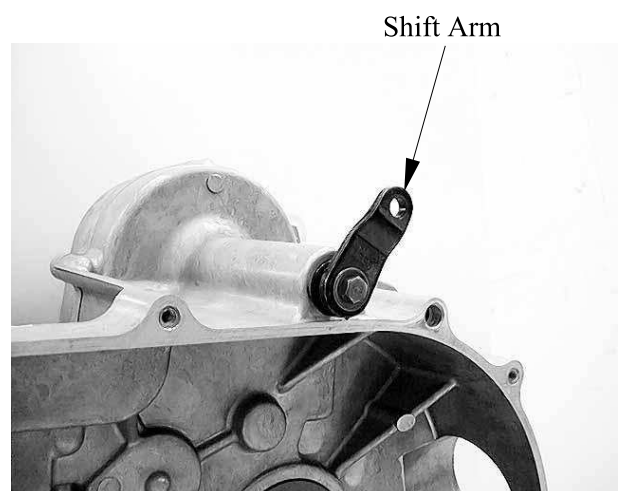
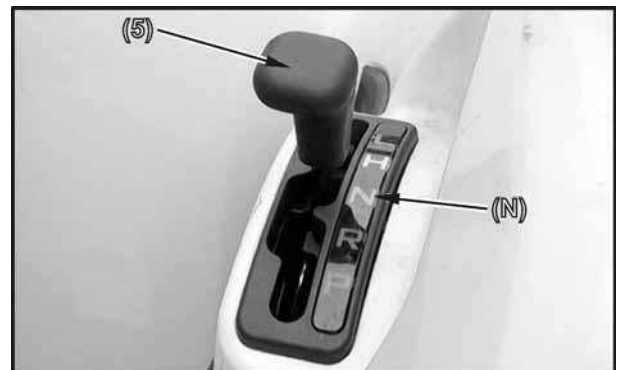

3. INSPECTION/ADJUSTMENT

- * When align the joint ball in the rod with the hole on the shift arm. Always keep the joint ball original position, do not turn the joint ball.

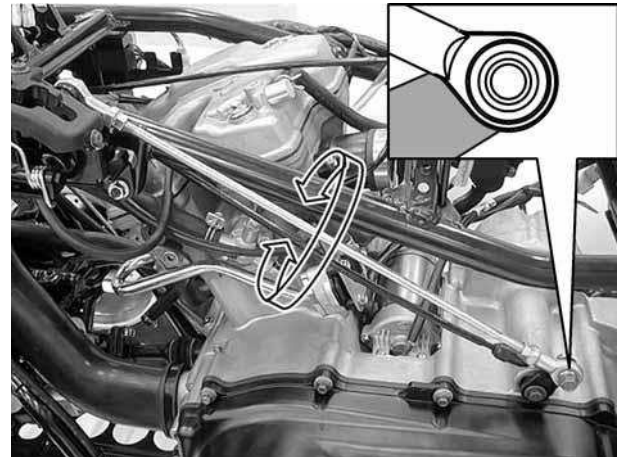

- * Damaged cable sheath may cause corrosion and interfere with the cable movement. An unsafe condition may result so replace such cable as soon as possible.

- * Hold cable end high and apply several drops of lubricant to cable.

Lock Nut

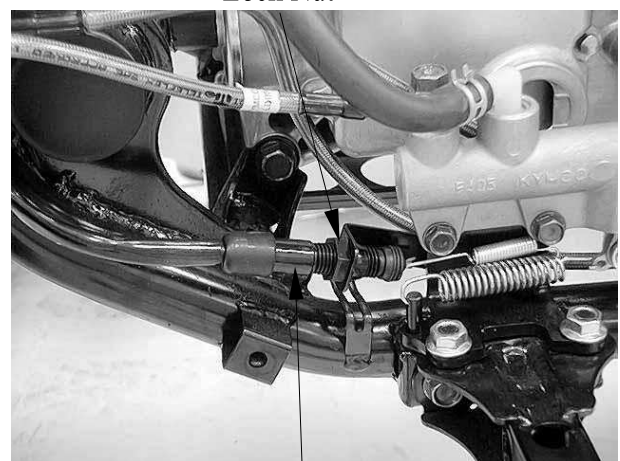

r

3. INSPECTION/ADJUSTMENT

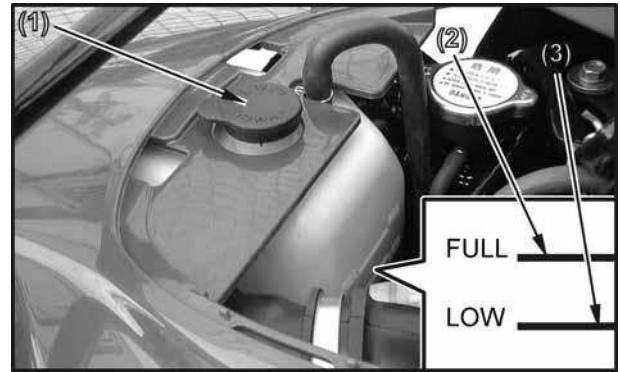

*

3. INSPECTION/ADJUSTMENT

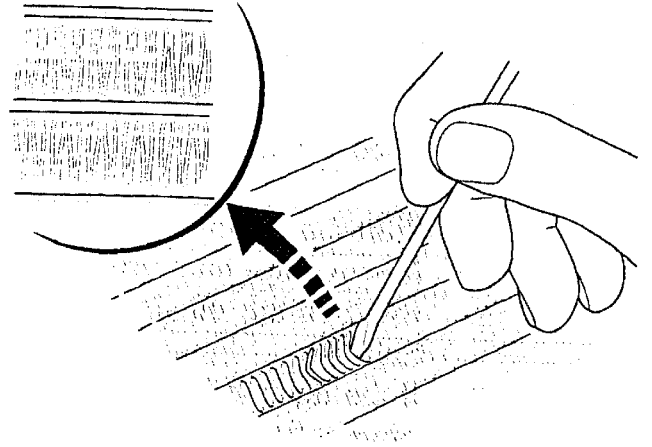

3. INSPECTION/ADJUSTMENT

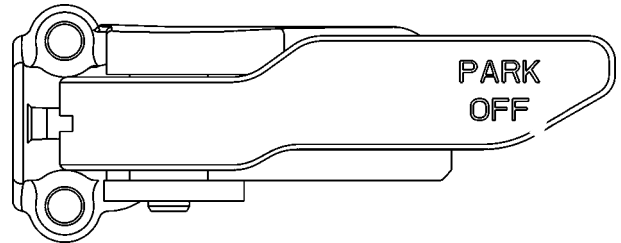

r

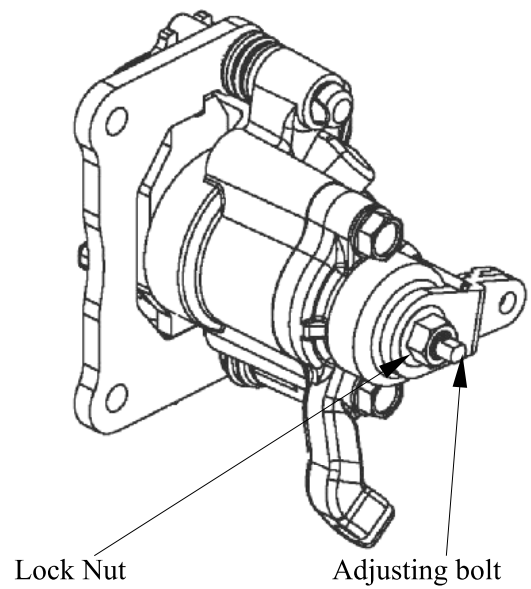

3. INSPECTION/ADJUSTMENT

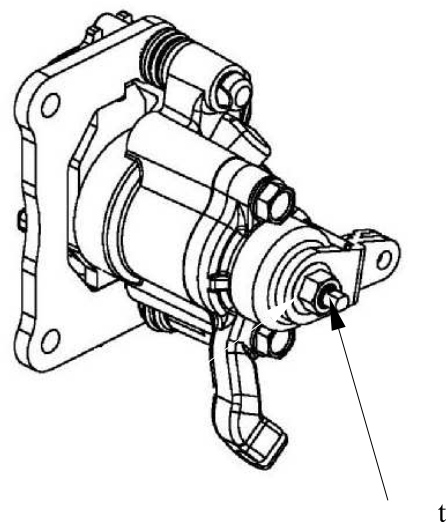
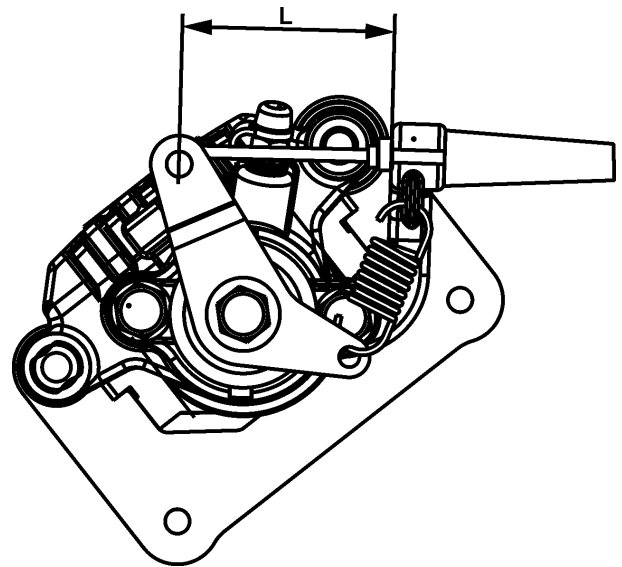

3. INSPECTION/ADJUSTMENT

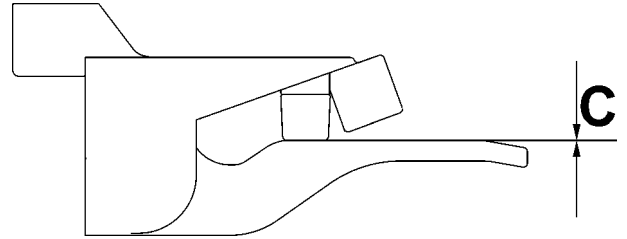

r

4. LUBRICATION SYSTEM

LUBRICATION SYSTEM DIAGRAM

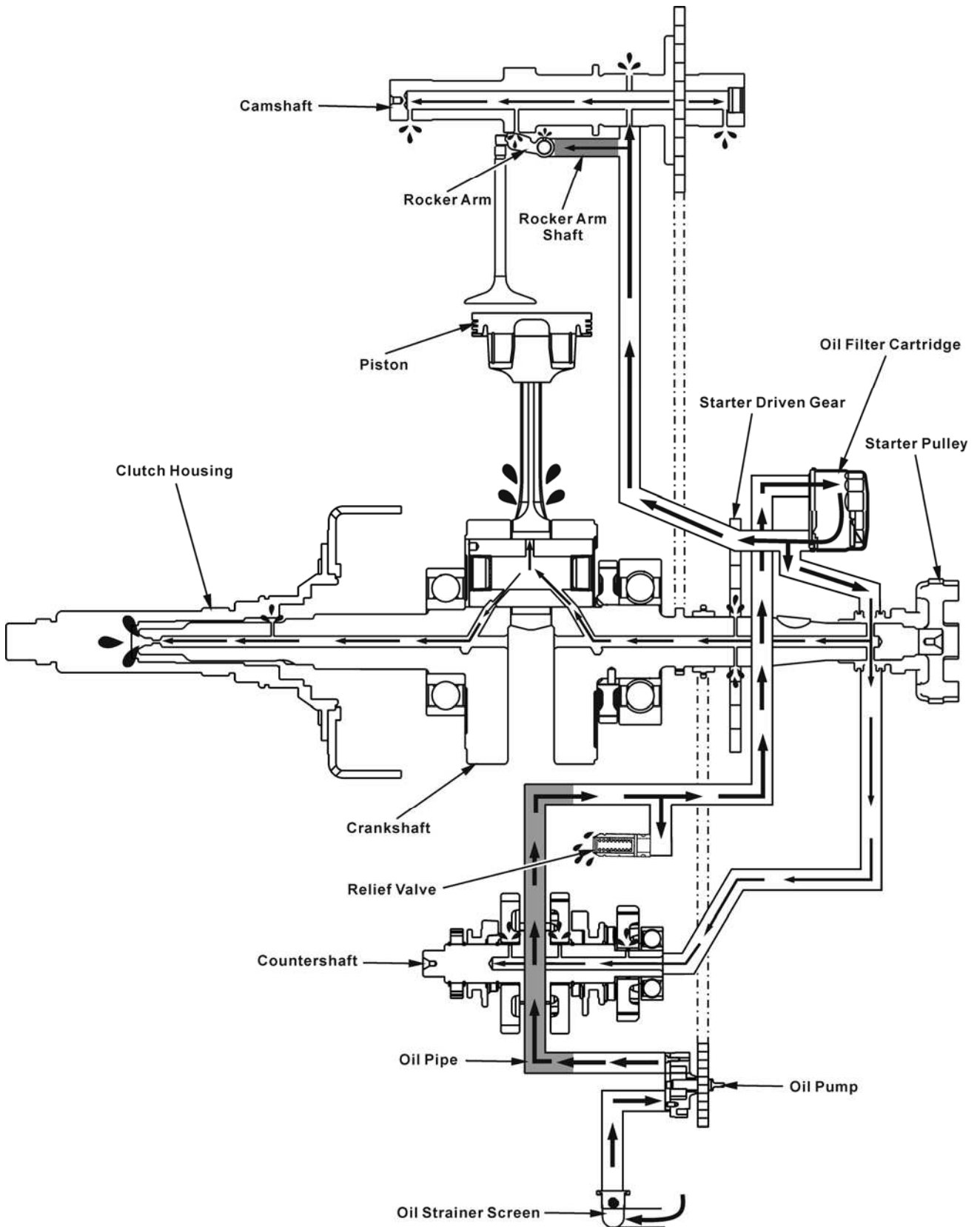

4. LUBRICATION SYSTEM

SERVICE INFORMATION

GENERAL INSTRUCTIONS

- The oil pump service may be done with the engine installed in the frame.
- When removing and installing the oil pump use care not to allow dust or dirt to enter the engine.
- If any portion of the oil pump is worn beyond the specified service limits, replace the oil pump as an assembly.
- After the engine has been installed check that there are no oil leaks and that oil pressure is correct.

SPECIFICATIONS

Unit: mm

| ITEM | | STANDARD | SERVICE LIMIT |
|------------------------|----------------|---|---------------|
| Engine oil capacity | At draining | 3 liter | — |
| | At disassembly | 3.6 liter | — |
| | | | — |
| Recommended engine oil | | KYMCO 4-stroke oil or equivalent motor oil API service classification SJ Viscosity: SAE 5W-50 | — |
| Oil pump rotor | Tip clearance | 0.15 max | 0.2 |
| | Body clearance | 0.15 – 0.2 | 0.25 |
| | Side clearance | 0.04 – 0.09 | 0.12 |

TORQUE VALUES

| | | |
|-------------------------|--------------------|---|
| Oil pump screw | 0.3 kgf-m (3 N-m) | |
| Oil strainer screen cap | 1.5 kgf-m (15 N-m) | Apply oil to the threads and seating surface. |
| Oil filter cartridge | 1 kgf-m (10 N-m) | Apply oil to the threads and seating surface. |
| Oil pipe bolt | 3.5 kgf-m (35 N-m) | Apply oil to the threads and seating surface. |

Special tool:

Oil seal & bearing drive A120E00014

4. LUBRICATION SYSTEM

TROUBLESHOOTING

Oil level low

- Oil consumption
- External oil leak
- Worn piston ring
- Incorrect piston ring installation
- Worn valve guide or seal

Oil contamination (White appearance)

- From coolant mixing with oil
 - Faulty water pump mechanical seal
 - Faulty head gasket
 - Water leak in crankcase

No oil pressure

- Oil level too low

- Oil pump drive chain broken
- Oil pump drive sprocket broken
- Oil pump damaged (pump shaft)
- Internal oil leak

Low oil pressure

- Pressure relief valve stuck open
- Clogged oil filter and strainer screen
- Oil pump worn or damaged
- Internal oil leak
- Incorrect oil being used
- Oil level too low

High oil pressure

- Pressure relief valve stuck closed
- Plugged oil filter, gallery, or metering orifice
- Faulty oil pump

Seized engine

- No or low oil pressure
- Clogged oil orifice/passage
- Internal oil leak
- Non-recommended oil used

Oil contamination

- Deteriorated oil
- Faulty oil filter
- Worn piston ring (White appearance with water or moisture)
 - Damaged water pump mechanical seal
 - Damaged head gasket
 - Oil relief not frequent enough

4. LUBRICATION SYSTEM

LUBRICATION CHECK HOLE

Remove the check hole plug/O-ring.
Start the engine.
Check the oil gushed from the hole. If not,
stop the engine immediately and determine
the cause.

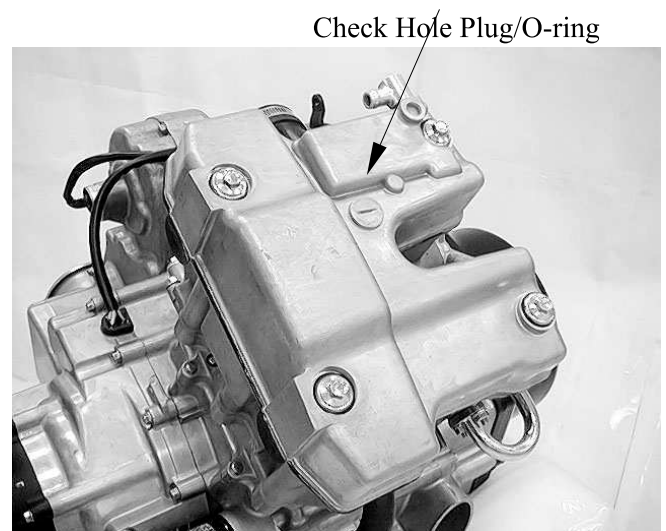

4. LUBRICATION SYSTEM

OIL PUMP REMOVAL/INSPECTION/ INSTALLATION

REMOVAL

Remove the flywheel and driven gear (refer to the “**STARTER CLUTCH REMOVAL/INSPECTION/INSTALLATION**” section in the chapter 19).

Remove the two bolts and oil pump drive chain guide.

Remove the two bolts and oil separator cover.

* When removing and installing the oil pump, use care not to allow dust or dirt to enter the engine..

Remove snap ring.

Remove the oil pump driven gear, then remove the oil pump drive chain.

Oil Pump Drive Chain Guide

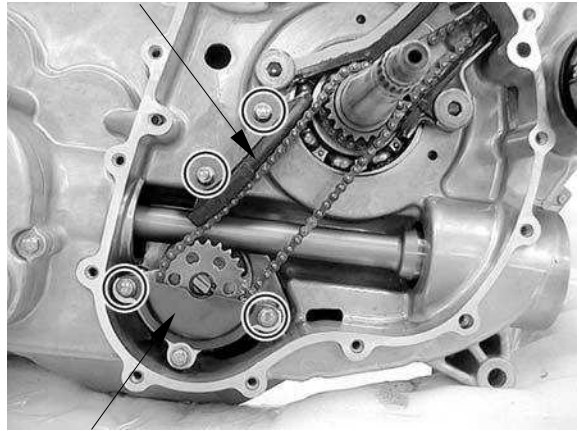

Oil Separator Cover

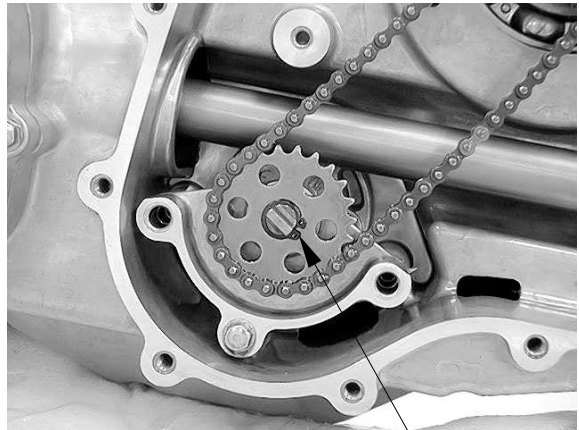

Snap Ring

Drive Chain

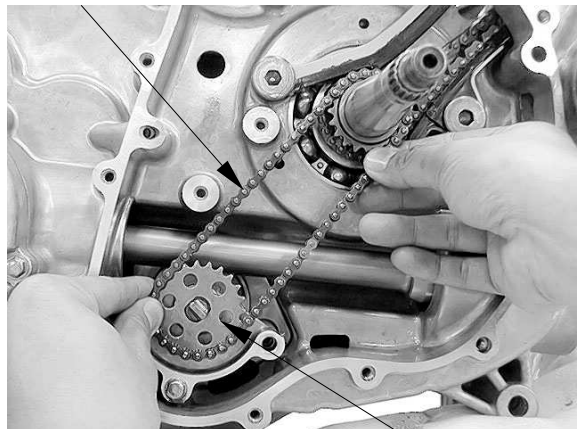

Driven Gear

4. LUBRICATION SYSTEM

Remove a bolt and then remove the oil pump holder.

Remove the two dowel pins.

Remove the two bolts and then remove the oil pump.

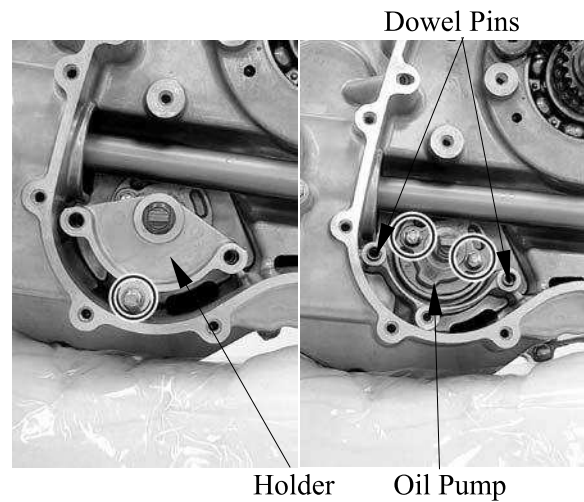

INSPECTION

Oil pump drive chain guide

Inspect the drive chain slipper surface of the drive chain guide for wear or damage.



INSTALLATION

Install the oil pump.

* Make sure the pump shaft rotates freely and arrow on the oil pump is upside.

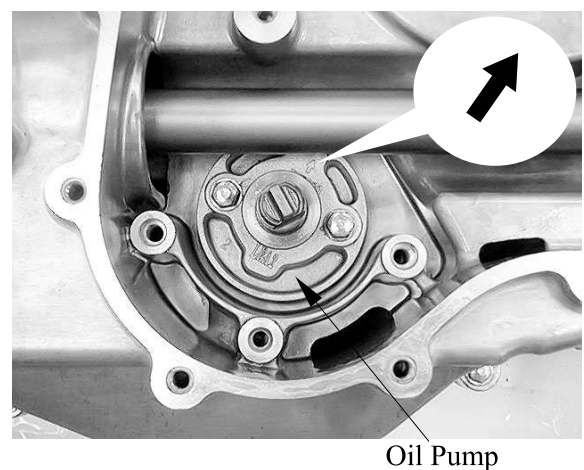

4. LUBRICATION SYSTEM

Install and tighten the two bolts securely.
Install two dowel pins

Install the holder, then install a bolt but do not tighten.

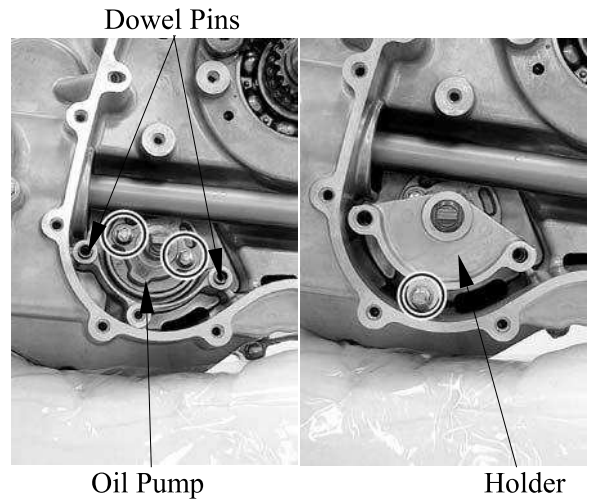

Install the driven gear and drive chain.

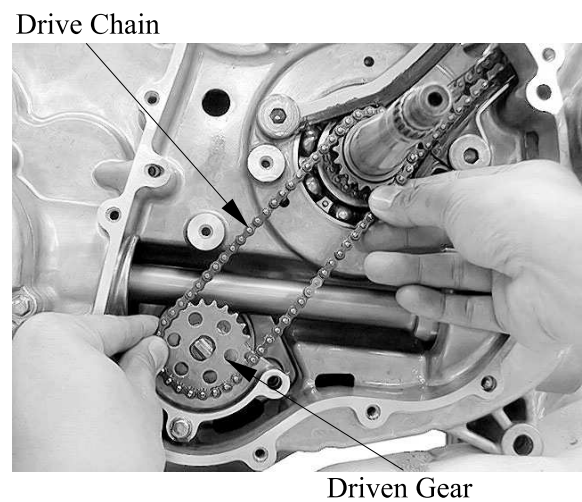

Install the snap ring.

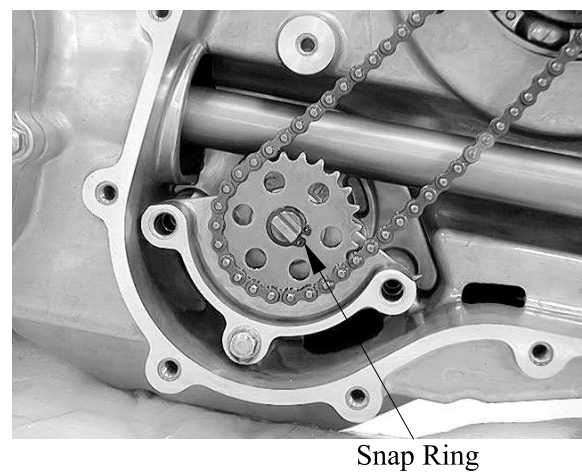

4. LUBRICATION SYSTEM

Install the chain guide, then install and tighten the two bolts securely.

Install the oil separator cover, then install and tighten the three bolts in a crisscross pattern in 2 or 3 steps.

Oil Pump Drive Chain Guide

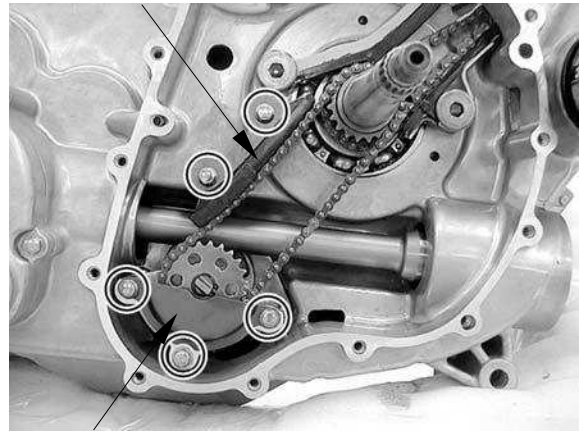

Oil Separator Cover

4. LUBRICATION SYSTEM

OIL PUMP DISASSEMBLY/INSPECTION/ ASSEMBLY

DISASSEMBLY

Remove the oil pump shaft.



Remove the screw and oil pump cover.

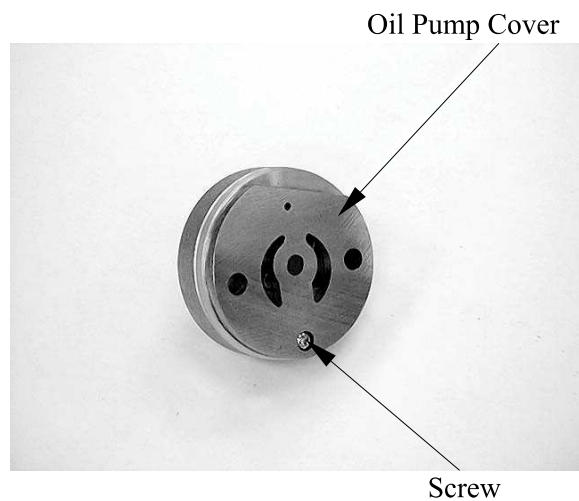

Remove the dowel pin, oil pump outer rotor and inner rotor.

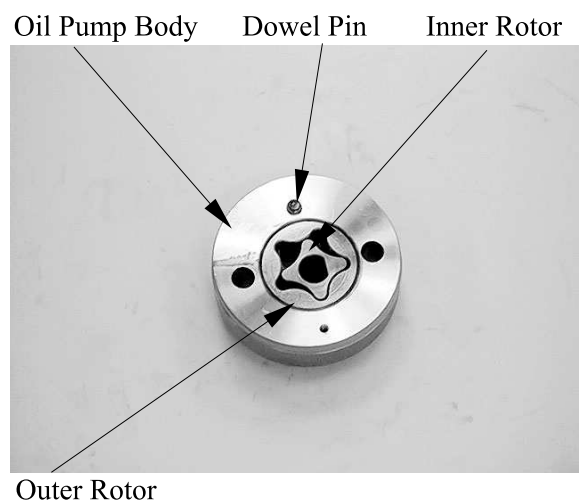

4. LUBRICATION SYSTEM

INSPECTION

Temporarily install the oil pump shaft.
Install the outer and inner rotors into the oil pump body.

Measure the tip clearance.

Service limit: 0.2 mm (0.008 in)

* Measure at several points and use the largest reading to compare the service limit.

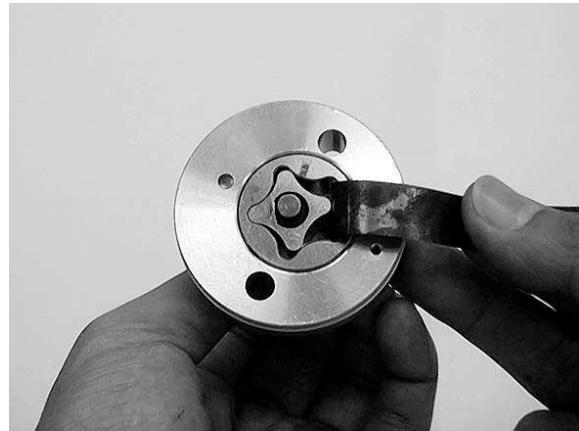

Measure the pump body clearance.

Service limit: 0.25 mm (0.01 in)

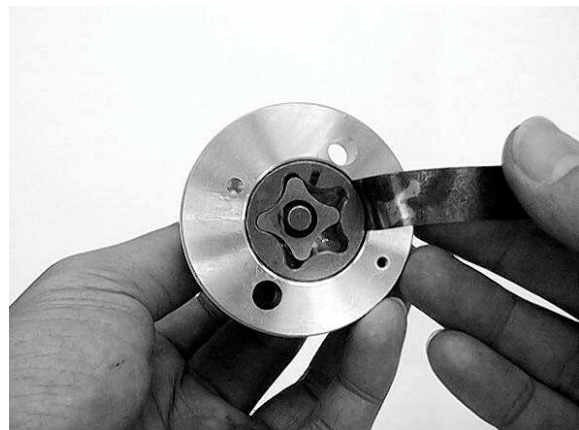

Measure the side clearance with the straight edge and feeler gauge.

Service limit: 0.12 mm (0.0048 in)

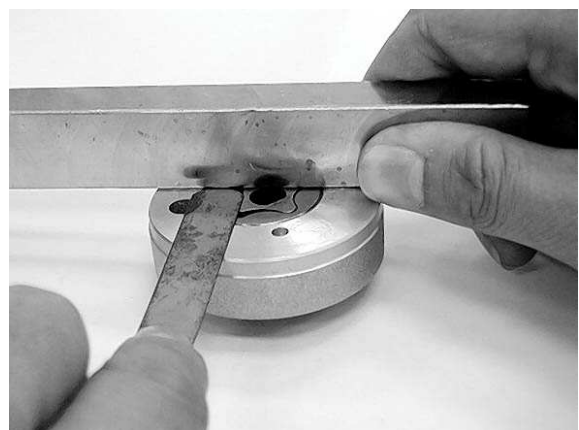

4. LUBRICATION SYSTEM

ASSEMBLY

Dip all parts in clean engine oil.

Install the outer rotor into the oil pump body.

Install the inner rotor into the outer rotor.

Install the oil pump shaft.

Install the dowel pin onto the oil pump body.

Install the oil pump cover onto the oil pump body by aligning the dowel pin.

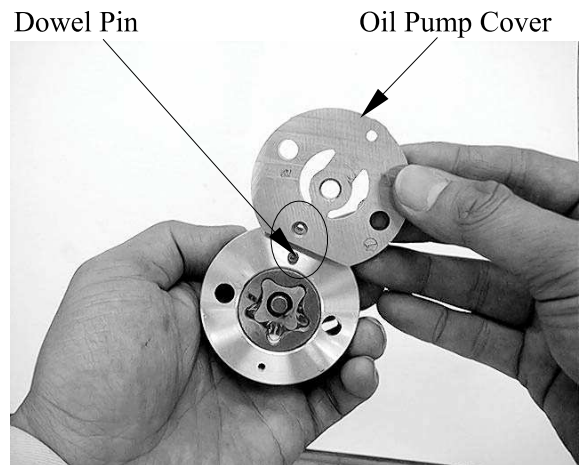

Install and tighten the screw to the specified torque.

Torqur: 3 N•m (0.3kgf•m, 2 lbf•ft)

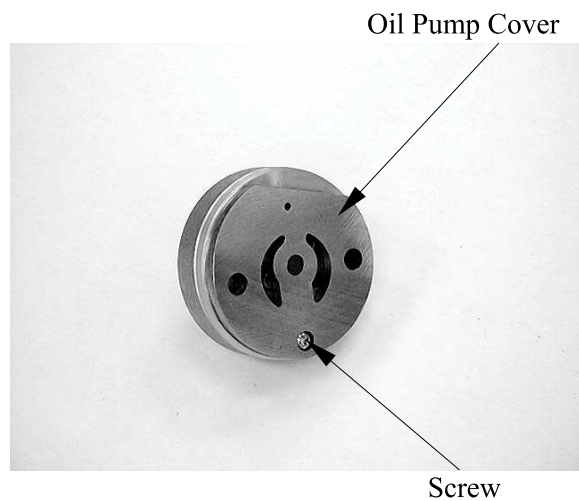

4. LUBRICATION SYSTEM

RIGHT CRANKCASE COVER DISASSEMBLY/ASSEMBLY

DISASSEMBLY

Remove the right crankcase cover (refer to the “ALTERNATOR STATOR REMOVAL/INSPECTION/INSTALLATION” in the chapter 17)

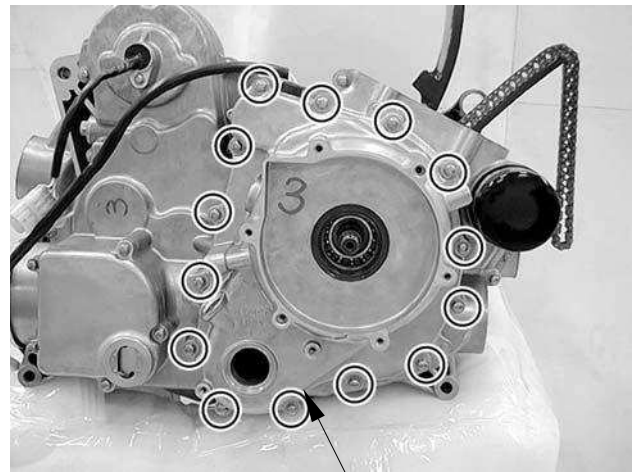

Right Crankcase Cover

Remove the oil seal.



Oil Seal

Remove the snap ring.

Remove the bearing by using the special tool.

Special tool:

Oil seal & bearing drive A120E00014

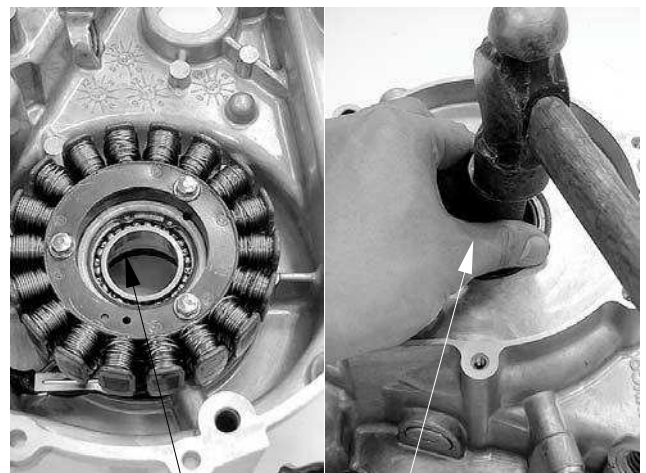

Snap Ring

Bearing Drive

4. LUBRICATION SYSTEM

ASSEMBLY

Install a new bearing by using the special tool.

Special tool:

Oil seal & bearing drive A120E00014

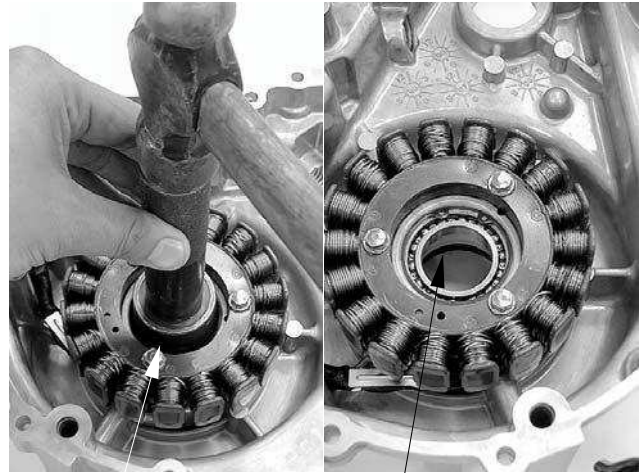

Bearing Drive

Snap Ring

Install a new oil seal.



Oil Seal

4. LUBRICATION SYSTEM

OIL PRESSURE RELIEF VALVE

REMOVAL

Remove the right crankcase (refer to the “**RIGHT CRANKCASE REMOVAL/INSTALLATION**” section in the chapter 11).

Remove the pressure relief valve and O-ring from the right crankcase.

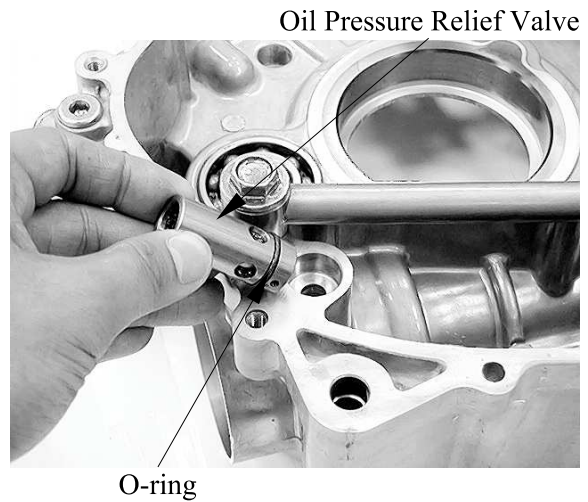

INSPECTION

Check the operation of the pressure relief valve by pushing on the piston.

INSTALLATION

Apply oil to a new O-ring and install the pressure relief valve groove, and install the relief valve to the right crankcase.

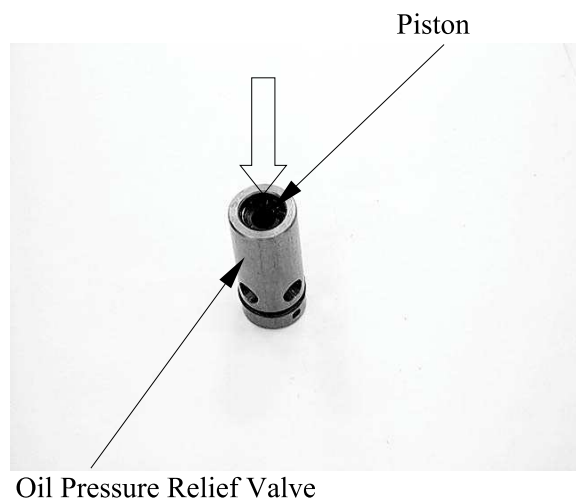

4. LUBRICATION SYSTEM

OIL PIPE REMOVAL/INSTALLATION

REMOVAL

Remove the two bolts, washers (on the oil pipe), oil pipe and washers (under oil pipe).

Bolts/Washers (on the oil pipe)

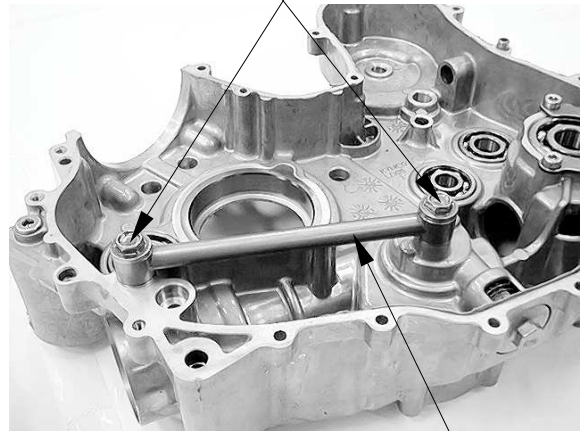

Oil Pipe/Washer (under oil pipe)

INSTALLATION

Install the inner washers on the right crankcase.

Washers



Install the oil pipe with the thick side face upward.

Thick Side

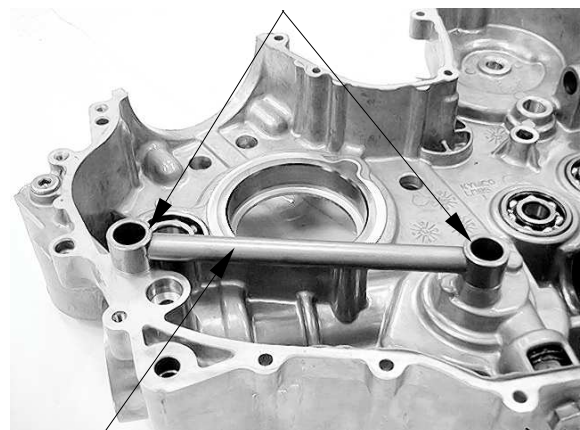

Oil Pipe

4. LUBRICATION SYSTEM

Apply clean engine oil to the bolts, then install the outer washers and two bolts. Tighten the two bolts to the specified torque.

Torque: 3.5 kgf-m (35 N-m, 25.2 lbf•ft)

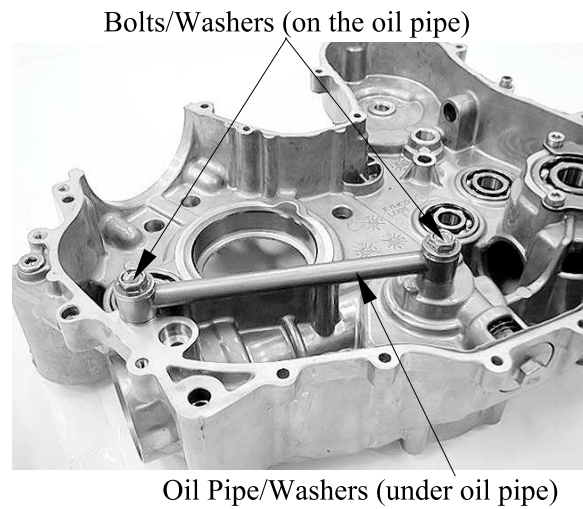

4. LUBRICATION SYSTEM

5. FUEL SYSTEM

5

FUEL SYSTEM

| | |
|--|------|
| SERVICE INFORMATION----- | 5- 2 |
| TROUBLESHOOTING----- | 5- 3 |
| FUEL TANK ----- | 5- 4 |
| FUEL VALVE ----- | 5- 4 |
| CARBURETOR REMOVAL/CHOKE INSPECTION/INSTALLATION-- | 5- 7 |
| CARBURETOR DISASSEMBLY/INSPECTION/ASSEMBLY ----- | 5- 9 |
| AIR CLEANER HOUSING----- | 5-19 |
| PAIR SOLENOID VALVE ----- | 5-20 |

5. FUEL SYSTEM

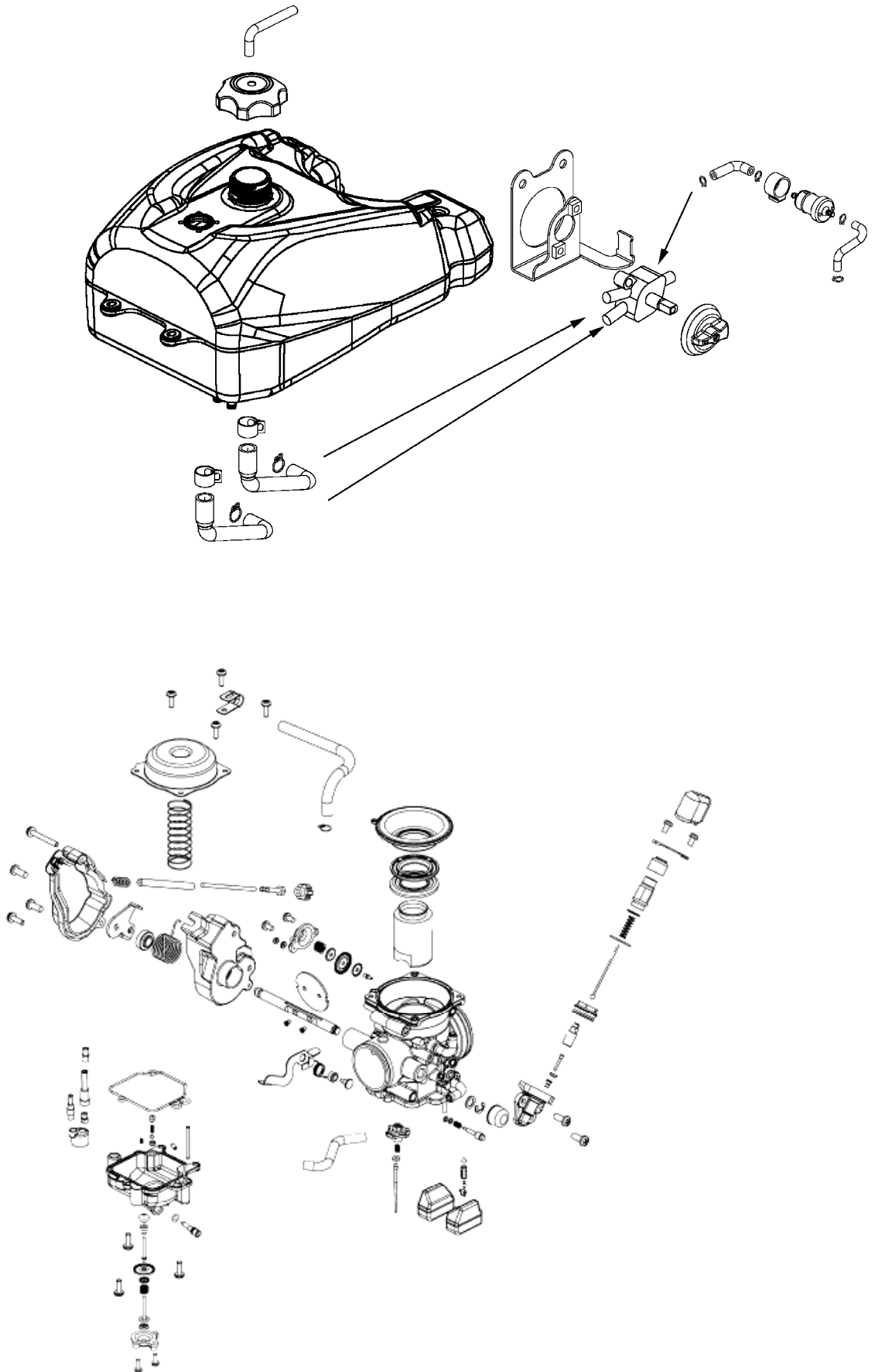

5. FUEL SYSTEM

SERVICE INFORMATION

GENERAL INSTRUCTIONS



Gasoline is very dangerous. When working with gasoline, keep sparks and flames away from the working area.
Gasoline is extremely flammable and is explosive under certain conditions. Be sure to work in a well-ventilated area.

- Do not bend or twist control cables. Damaged control cables will not operate smoothly.
- When disassembling fuel system parts, note the locations of O-rings. Replace them with new ones during reassembly.
- Before float chamber disassembly, loosen the drain screw to drain the residual gasoline into a clean container.
- After the carburetor is removed, plug the intake manifold side with a clean shop towel to prevent foreign matters from entering.
- When cleaning the carburetor air and fuel jets, the O-rings and diaphragm must be removed first to avoid damage. Then, clean with compressed air.
- When the machine is not used for over one month, drain the residual gasoline from the float chamber to avoid erratic idling and clogged slow jet due to deteriorated fuel.

SPECIFICATIONS

| Item | | Standard |
|-------------------------|----------|--|
| Type | | KYMCO CVK |
| Mark | | LFE9-IT (ON ROAD) LFE9-US(OFF ROAD) |
| Bore size | | φ38 mm |
| Float level | | 38cc |
| Main jet No. | ON ROAD | #128 |
| | OFF ROAD | #126 |
| Slow jet No. | | #40 |
| BY-ST jet No. | | #55 |
| Idle speed | | 1500±100 rpm |
| Throttle grip free play | | 3~5 mm |
| Pilot screw opening | | 2±1/2 |

5. FUEL SYSTEM

TROUBLESHOOTING

Engine cranks but won't start

- No fuel in tank
- No fuel to carburetor
- Cylinder flooded with fuel
- No spark at plug
- Clogged air cleaner
- Intake air leak
- Improper throttle operation

Engine idles roughly, stalls or runs poorly

- Excessively used choke
- Ignition malfunction
- Faulty carburetor
- Poor quality fuel
- Lean or rich mixture
- Incorrect idle speed

Misfiring during acceleration

- Faulty ignition system
- Faulty carburetor

Backfiring at deceleration

- Float level too low
- Incorrectly adjusted carburetor
- Faulty exhaust muffler

Engine lacks power

- Clogged air cleaner
- Faulty carburetor
- Faulty ignition system

Lean mixture

- Clogged carburetor fuel jets
- Float level too low
- Intake air leak
- Clogged fuel tank cap breather hole
- Kinked or restricted fuel line

Rich mixture

- Float level too high
- Clogged air jets
- Clogged air cleaner

5. FUEL SYSTEM

FUEL TANK

REMOVAL



Remove the seat, right and left side frame cover and fuel tank cover (refer to the “**FRAME COVERS**” section in the chapter 2).

Switch the fuel valve “OFF”.
Remove the 2 mounting bolts.
Disconnect the fuel tube from carburetor.

Disconnect the fuel unit connectors.
Remove the two bolts and two nuts from the fuel tank, then remove the fuel tank.

INSTALLATION

Fuel tank installation is in the reverse order of removal.

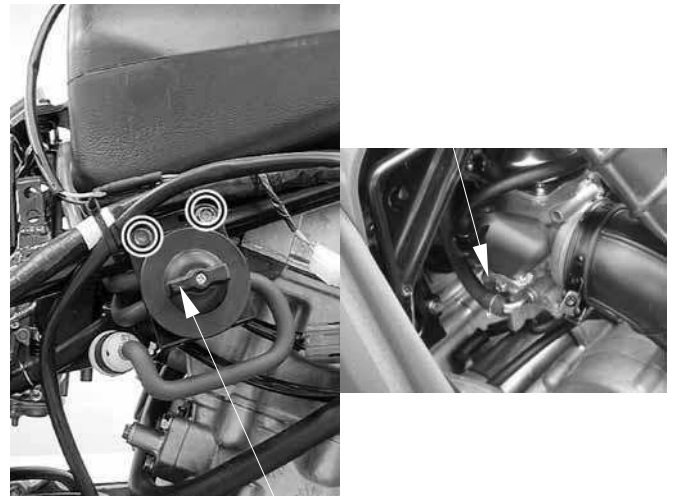

Fuel Valve

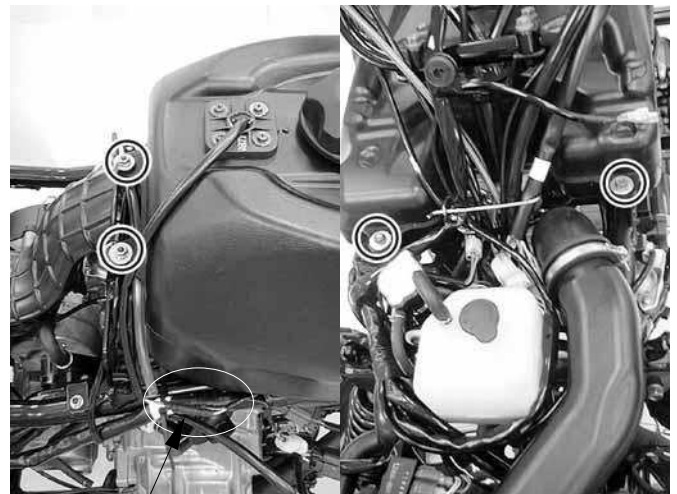

Fuel Unit Connectors

FUEL VALVE

REMOVAL

- *
 - Keep sparks and flames away from the work area.
 - Drain gasoline into a clean container.

Remove the screw and then remove control switch.
Disconnect all fuel tubes and remove the two screws, then remove fuel valve.



5. FUEL SYSTEM

DISASSEMBLY

Remove the two screws on the retaining ring and then remove retaining ring.
Remove the washer and control shaft.

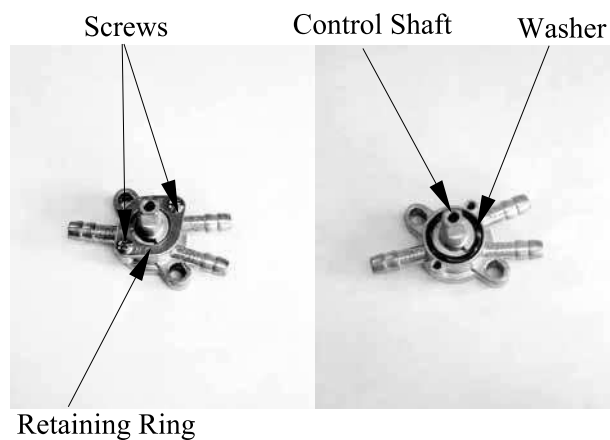

Remove the rubber gasket from the fuel valve body.

INSPECTION

Inspect the fuel valve body for dirt and clog.
Clean if necessary.

Replace the rubber gasket with new ones if they are damaged or deteriorated.

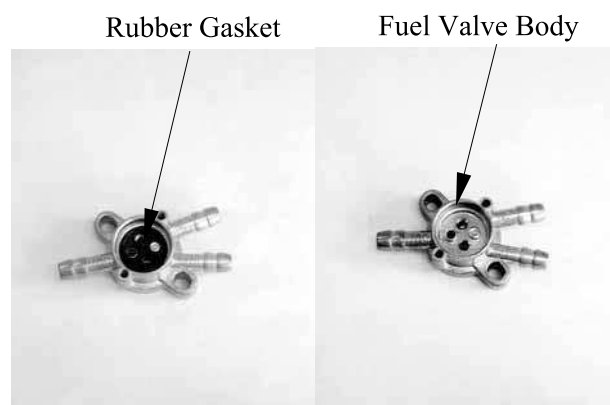

Replace the O-ring with a new one if they are damaged or deteriorated.

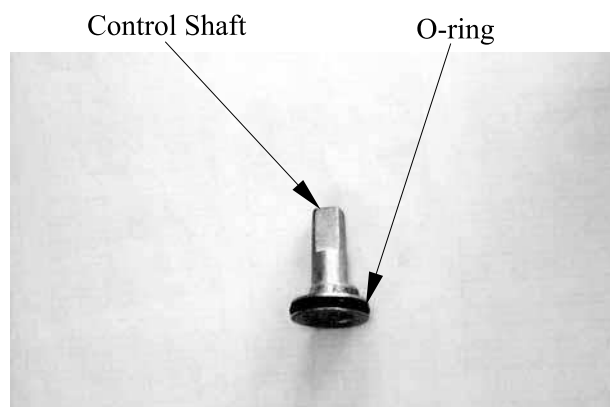

5. FUEL SYSTEM

ASSEMBLY

Reverse the “DISASSEMBLY” procedures. Install rubber gasket, control shaft, washer and retaining ring.

- * Aligning the tab on the control shaft with the outlet duct in the fuel valve body.
- * Aligning the tab on the retaining ring with the outlet duct in the fuel valve body.

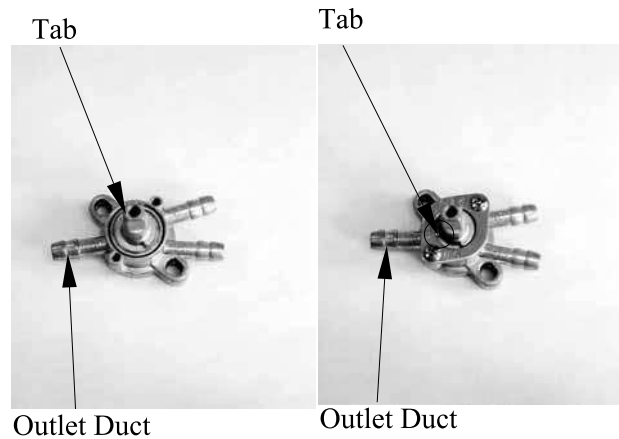

INSTALLATION

Reverse the “REMOVEAL” procedures. Connect all fuel tube.

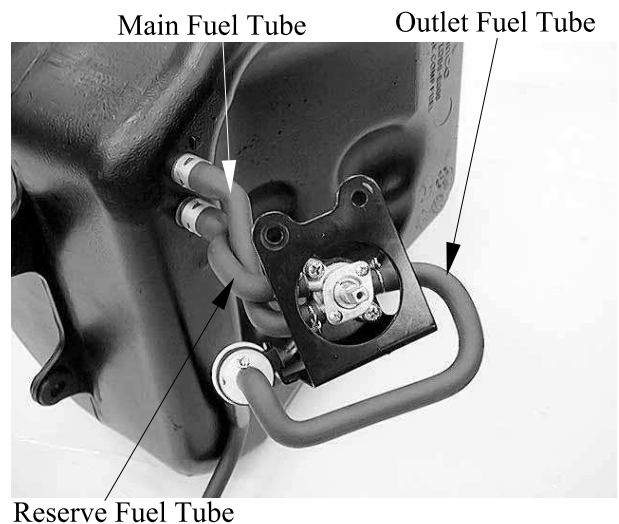

Install the fuel filter with the arrow mark facing forward.

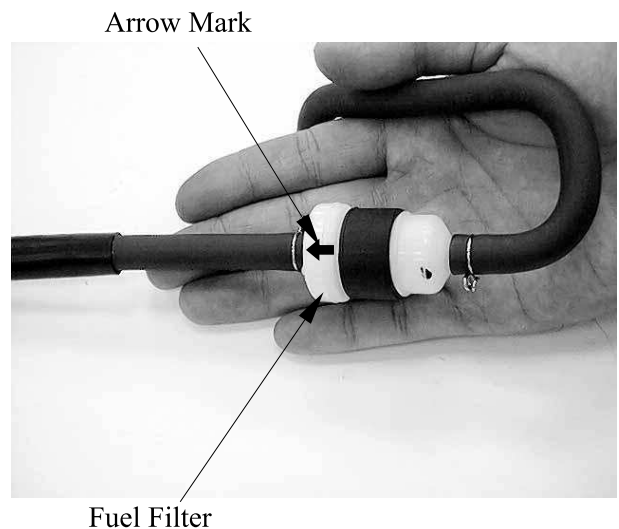

5. FUEL SYSTEM

CARBURETOR REMOVAL/CHOKE INSPECTION/INSTALLATION

REMOVAL

Remove the fuel tank (refer to the “**FUEL TANK**” section in this chapter).
Remove the air cleaner housing (refer to the “**AIR CLEANER HOUSING**” section in this chapter).

Disconnect the over flow hose.
Loosen the carburetor clamp screw, then remove carburetor from intake pipe.

Remove two screws, then remove the throttle valve cover.

Disconnect the throttle cable from carburetor.

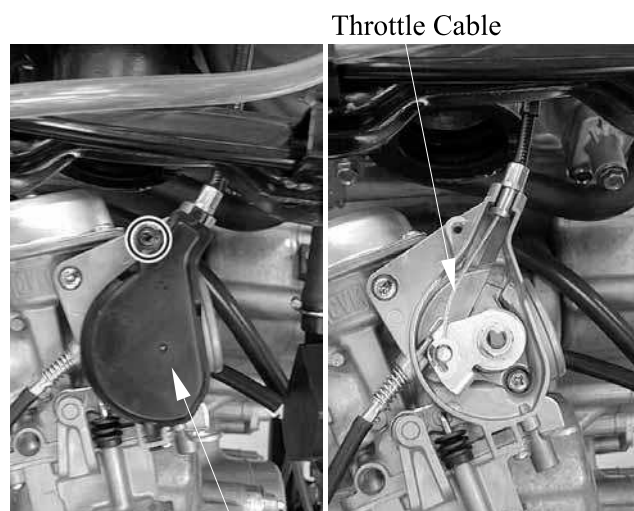

Throttle Valve Cover

Remove the auto choke connector from carburetor, then remove the carburetor.

5. FUEL SYSTEM

CHOKE INSPECTION

Inspection the choke plunger, spring and O-ring for bends, wear or damage.

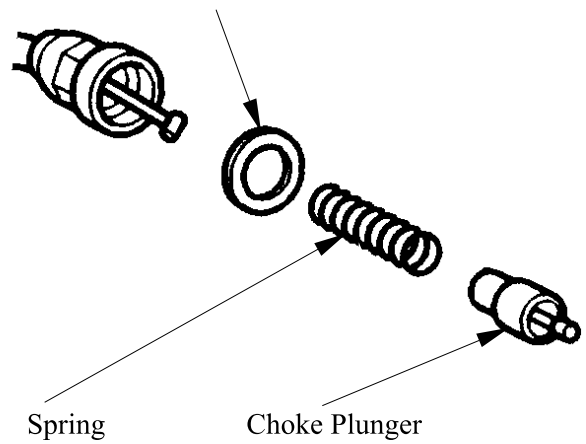

INSTALLATION

Installation is in the reverse order of removal.

- * Make sure the lug on the carburetor into the cutout on the intake pipe.

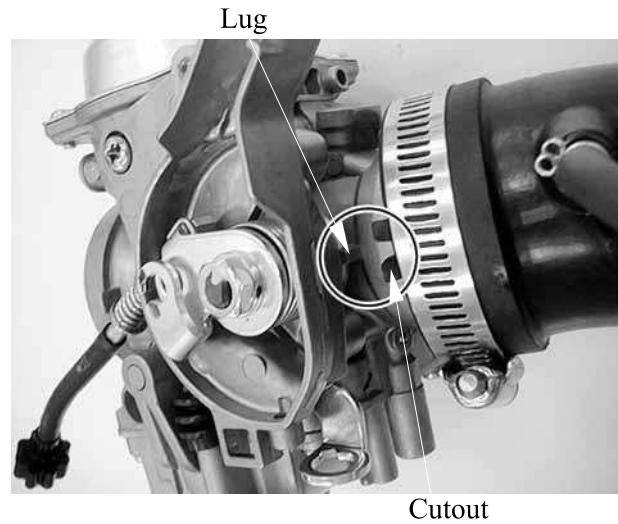

- * Make sure the lug on the carburetor into the cutout on the air cleaner hose.

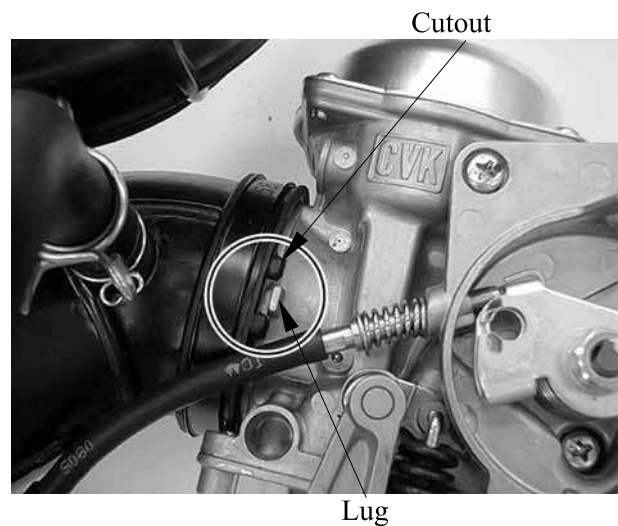

5. FUEL SYSTEM

CARBURETOR DISASSEMBLY/INSPECTION/ ASSEMBLY

DISASSEMBLY

Remove the carburetor (refer to the "CARBURETOR REMOVAL/CHOKE INSPECTION/INSTALLATION" section in this chapter).

Loosen the drain screw to drain the gasoline from the float chamber.

- *
 - Keep sparks and flames away from the work area.
 - Drain gasoline into a clean container.
 - Do not loosen or tighten the painted bolts and screws of the carburetor. Loosening or tightening them can cause throttle and piston valve synchronization failure.

Remove the four screws and top cap

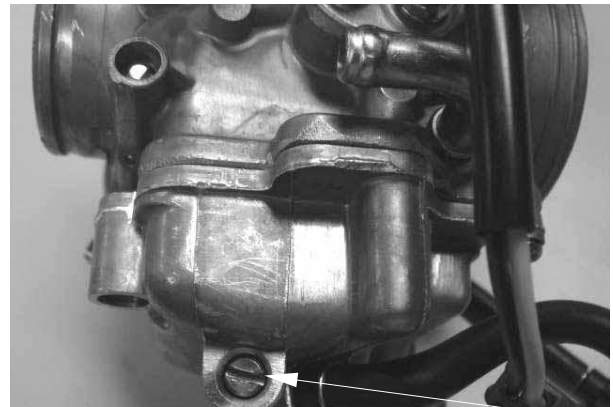

Fuel Drain Plug



Top Cap

Remove the spring and piston valve.

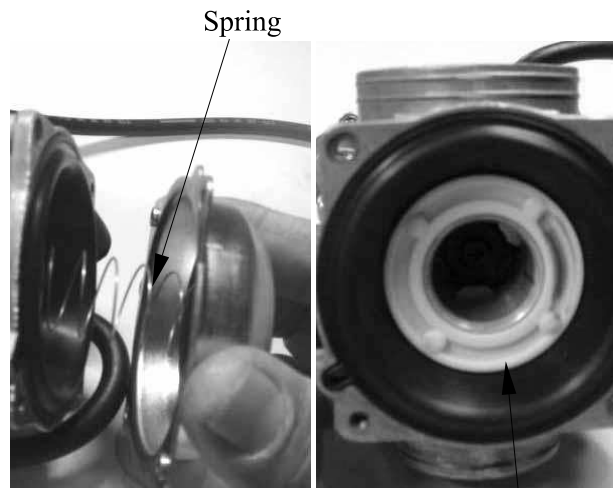

Spring

Piston Valve

5. FUEL SYSTEM

Remove the spring retainer, jet needle.

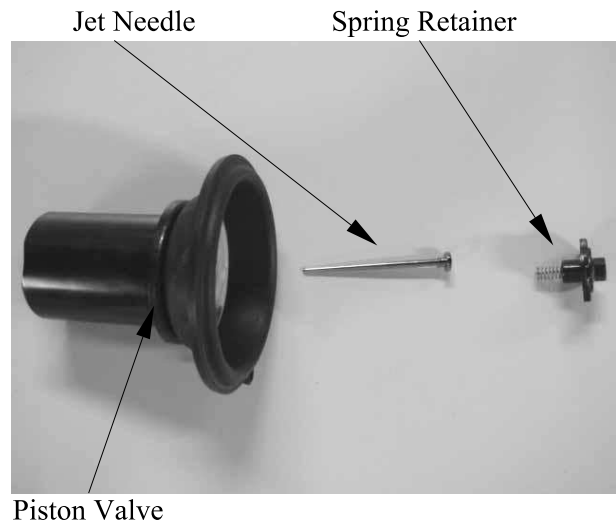

5. FUEL SYSTEM

Remove the four screws and float chamber.

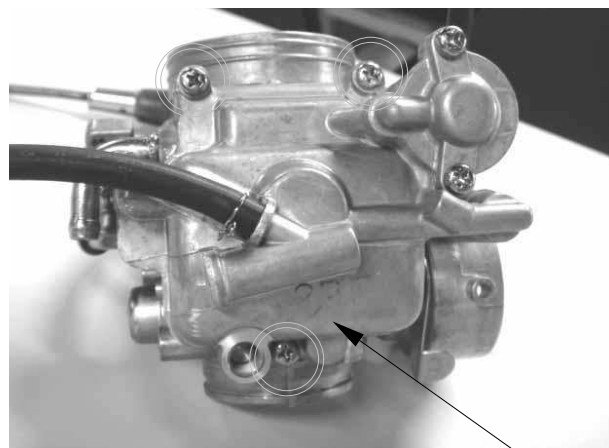

Float Chamber

Pull float pin outs, then remove the float and float valve.

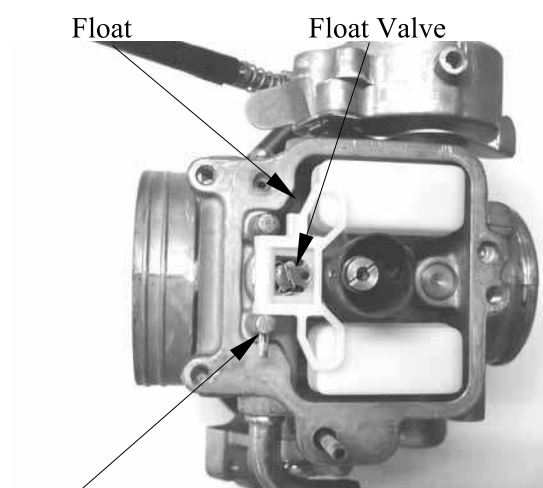

Float Valve

Remove the slow jet.

Remove main jet.

Remove the needle jet holder.

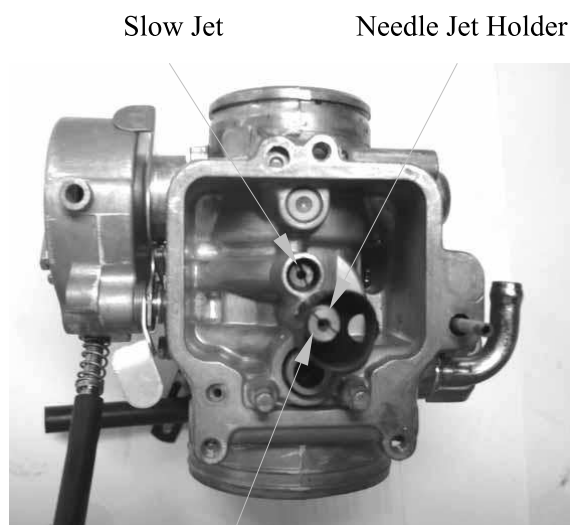

Main Jet

5. FUEL SYSTEM

Remove the needle jet.

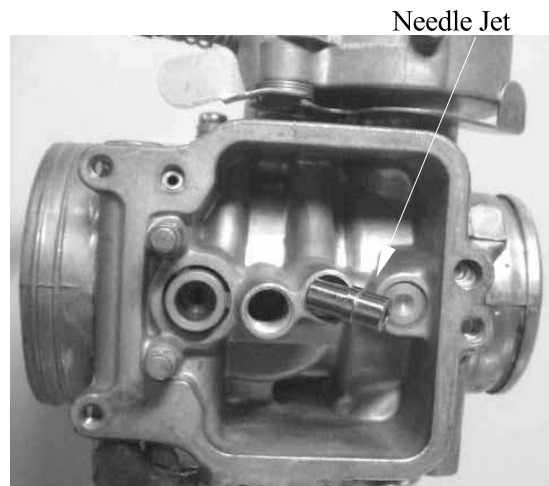

Remove the pilot screw, spring, washer and O-ring.

* Before pilot screw removal, slowly turn the pilot screw clockwise and count the number of turns until the screw is lightly seated. Make a note of how many turns were made so the screw can be reset correctly.

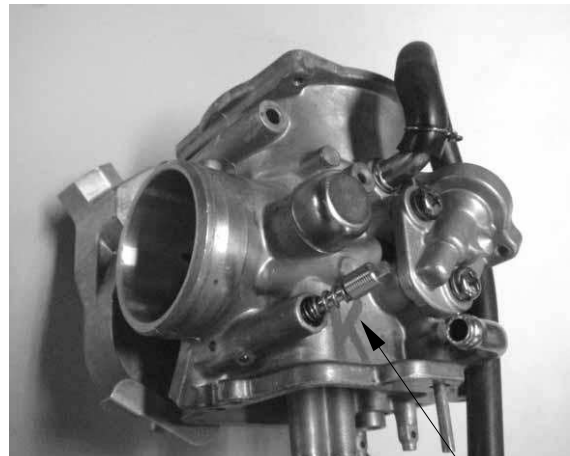

5. FUEL SYSTEM

INSPECTION

CARBURETOR BODY/JETS CLEANING

Check carburetor body and each jet for wear or damage.

Clean all jets with a spray-type carburetor cleaner and dry them using compressed air.

Clean all circuits of the carburetor thoroughly-not just the perceived problem area.

Clean the circuits in the carburetor body with a spray-type cleaner and allow each circuit to soak, if necessary, to loosen dirt and varnish. Blow the body dry using compressed air.

*

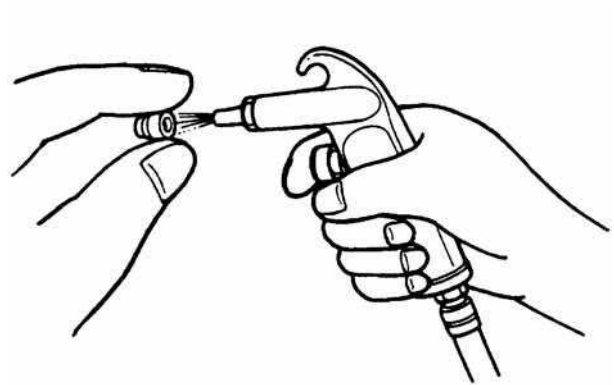
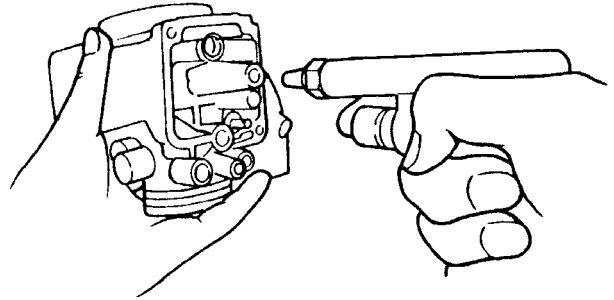

After cleaning, reassemble the carburetor with new seals.

5. FUEL SYSTEM

Check the float and float tang for deformation or damage.

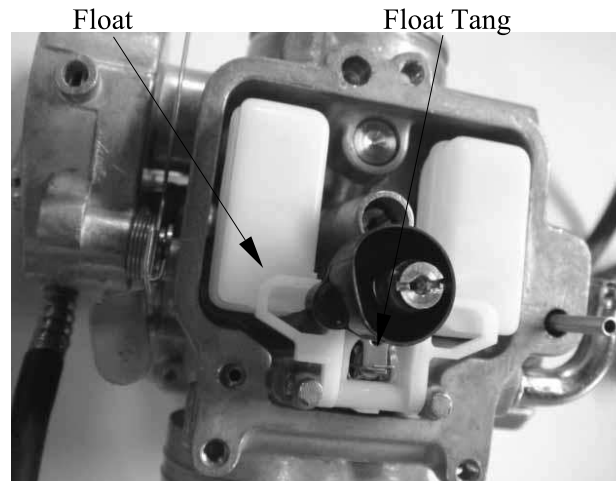

Check the float valve and valve seat for foreign substance, clogging or damage.

Check the tip of the float valve, where it contacts the valve seat, for stepped wear or contamination.

Check the operation of the float valve.

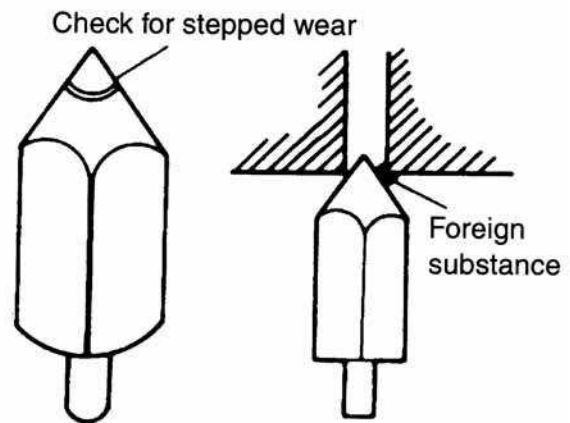

Check the piston valve for scratches, wear and damage.

Check the rubber diaphragm for tears.

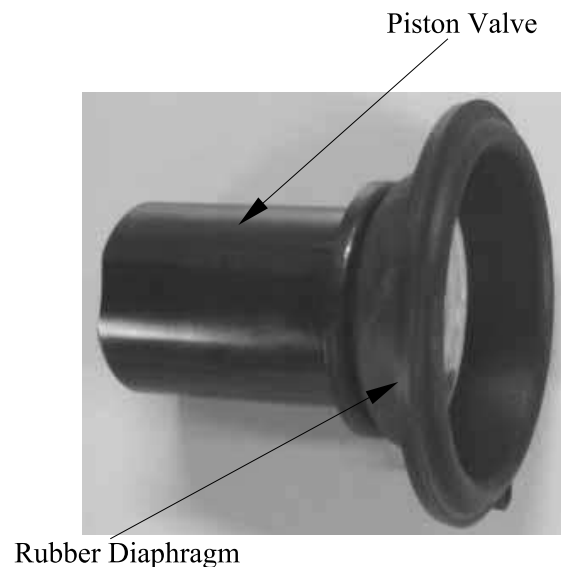

5. FUEL SYSTEM

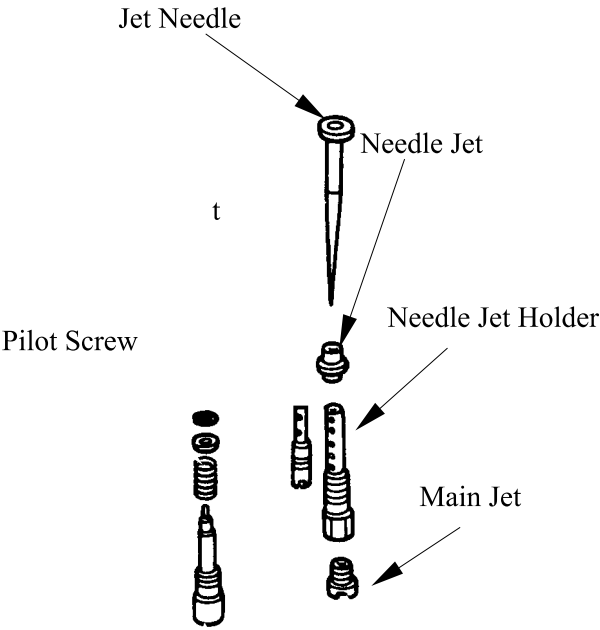
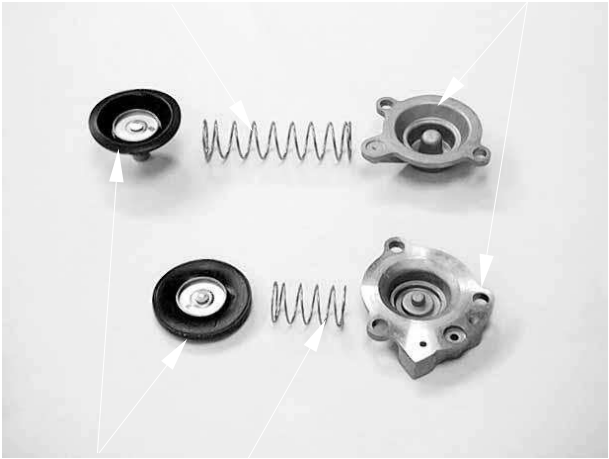
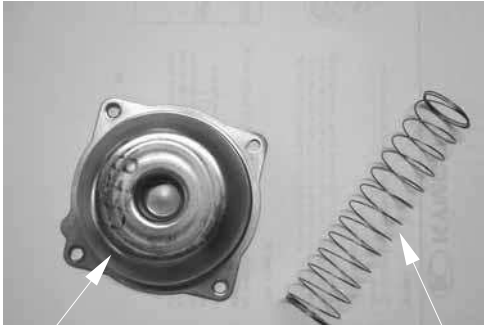

5. FUEL SYSTEM

Insert the piston valve into the carburetor body, and check for free movement. If stick is found, replace the part with a new one.

Check throttle valve for free movement.
If stick is found, replace the part with a new carburetor.

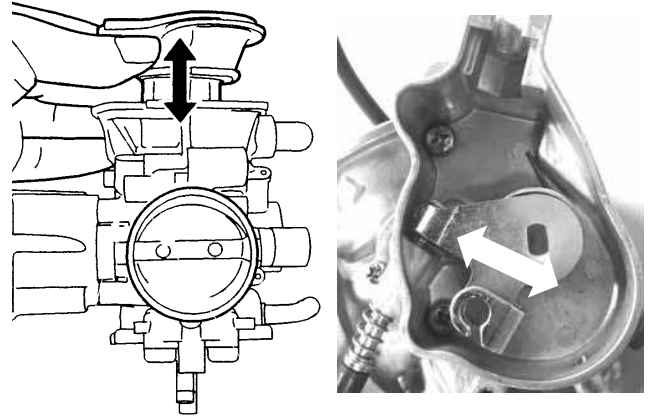

Check the float level after checking the float valve, valve seat and float.

Set the carburetor so that the float valve end just contacts the float arm lip. Make sure the float valve tip is securely in contact with the valve seat.
Measure the float level with the float level gauge.

Float level (A): 17 mm

Bend the tongue as necessary to bring the float height (A) to the specified level.

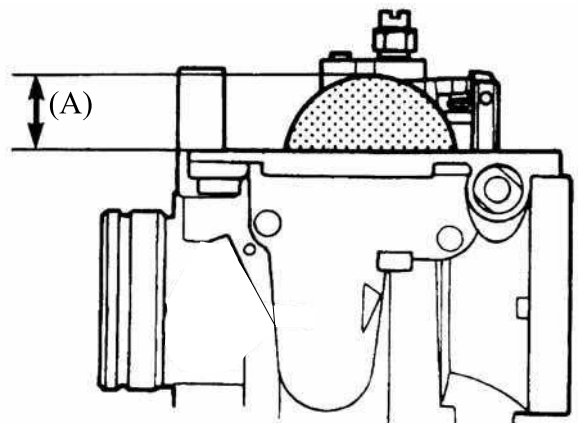

5. FUEL SYSTEM

ASSEMBLY

Carburetor reassembly can be performed in the reverse order of disassembly. When reassembling, carefully observe the following instructions.

*

- Assemble the parts taking consideration of their function.
- Before assembling, wash all of the parts in a clean petroleum based solvent.
- Replace O-rings and seals with new ones.
- After cleaning, reinstall the pilot screw to the original setting by turn the screw in until it lightly seats, and then backing it out the same number of turns counted during disassembly.

- (1) Spring
- (2) Retainer
- (3) Jet needle
- (4) Piston valve
- (5) Cover
- (6) Spring
- (7) Casting enrichment valve
- (8) Choke air in
- (9) Main jet
- (10) Needle jet holder
- (11) Needle jet
- (12) Slow jet
- (13) Float valve
- (14) Float
- (15) Float pin
- (16) Pilot screw
- (17) Cap
- (18) Cover
- (19) Float Chamber

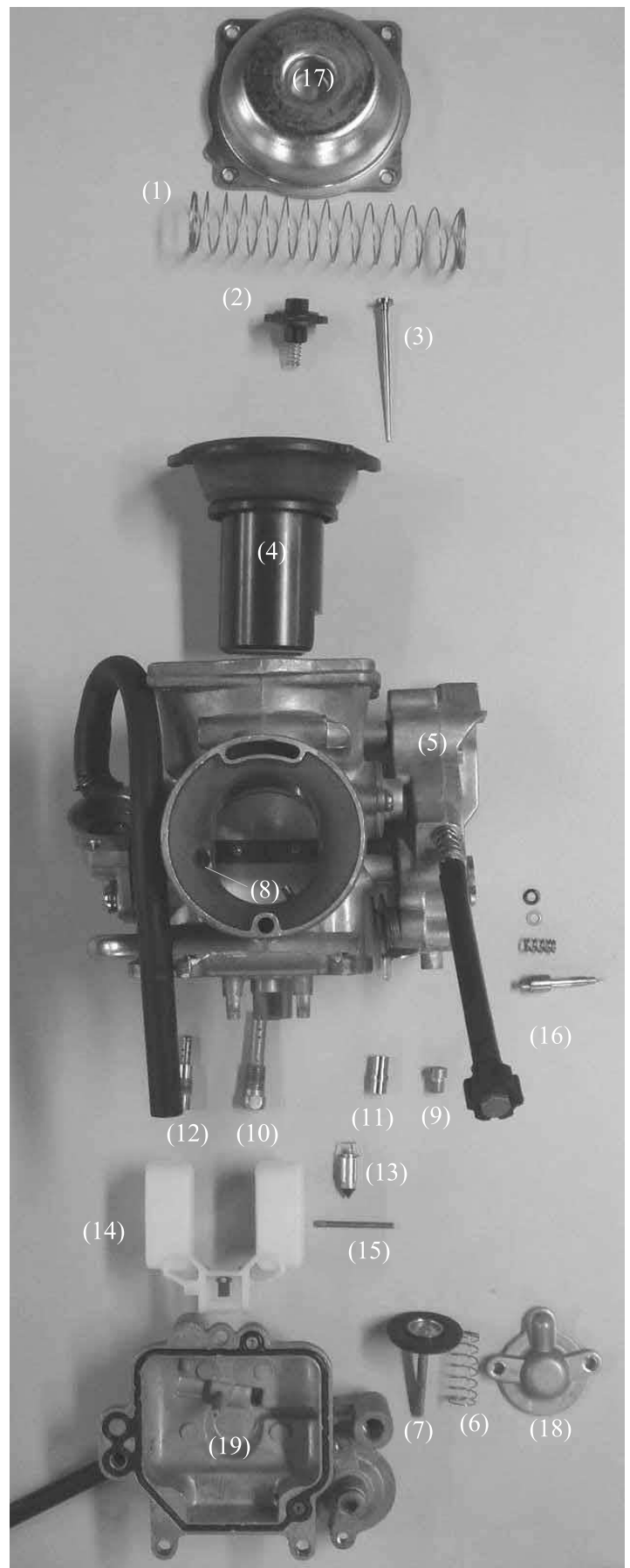

5. FUEL SYSTEM

Fit a new O-ring in to the float chamber groove securely.

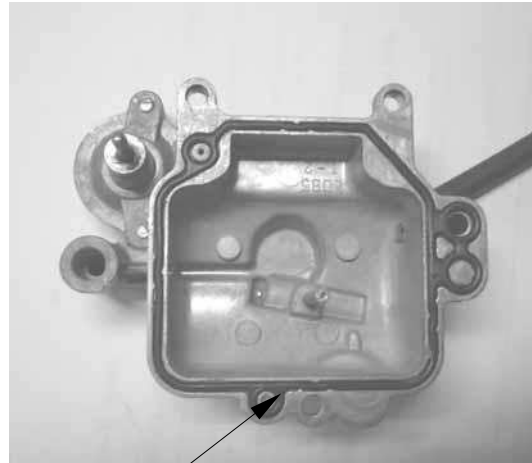

O-ring

Assemble the accelerating pump diaphragm and new O-ring.

* Install the accelerating pump diaphragm with the small convex facing up.

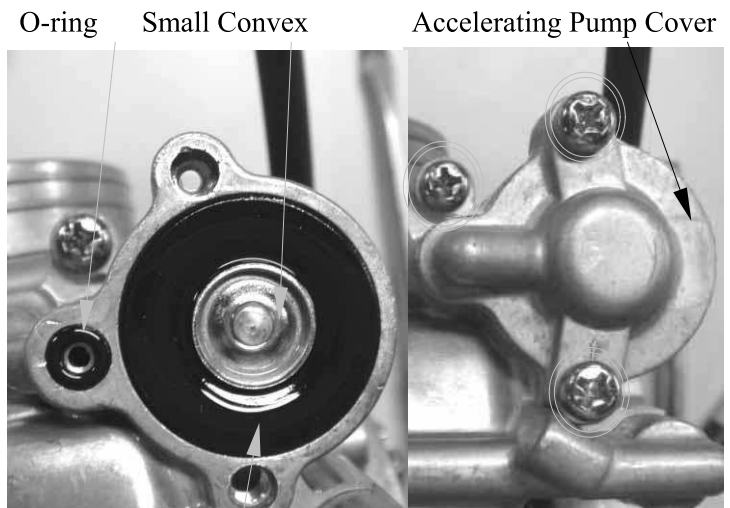

Accelerating Pump Diaphragm

5. FUEL SYSTEM

AIR CLEANER HOUSING

REMOVAL/INSTALLATION

Remove the seat and side covers (refer to the “**FRAME COVERS**” section in the chapter 2).

Loosen the carburetor-to-air cleaner connecting tube band screw.



Remove the clip and disconnect the crankcase breather hose from the crankcase. Remove the mounting bolts and then remove the air cleaner housing from the carburetor and the intake duct.

Installation is in the reverse order of removal.

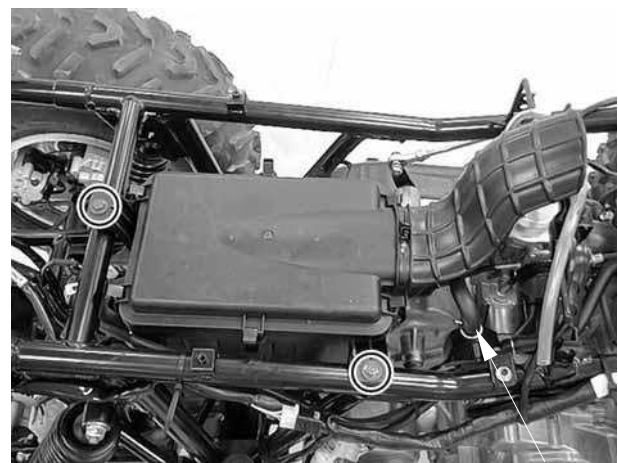

5. FUEL SYSTEM

PAIR SOLENOID VALVE

REMOVAL/INSTALLATION

Disconnect air supply hose and vacuum hose from the air solenoid valve, then remove the air solenoid valve from frame.

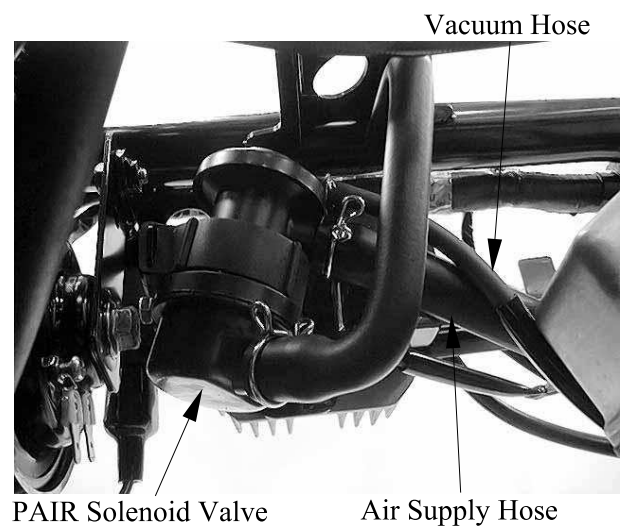

Installation is in the reverse order of removal.



6. COOLING SYSTEM

COOLING SYSTEM

6

| | |
|--------------------------------|------|
| SYSTEM FLOW PATTERN----- | 6- 1 |
| SERVICE INFORMATION----- | 6- 2 |
| TROUBLESHOOTING----- | 6- 4 |
| COOLING SYSTEM TESTING----- | 6- 5 |
| COOLANT REPLACEMENT ----- | 6- 5 |
| THERMOSTAT----- | 6- 8 |
| WATER PUMP ----- | 6-11 |
| RADIATOR ----- | 6-14 |
| FAN MOTOR SWITCH ----- | 6-15 |
| FAN MOTOR ----- | 6-16 |
| WATER TEMPERATURE SENSOR ----- | 6-17 |
| RAIDATOR RESERVE TANK ----- | 6-18 |

6. COOLING SYSTEM

SYSTEM FLOW PATTERN

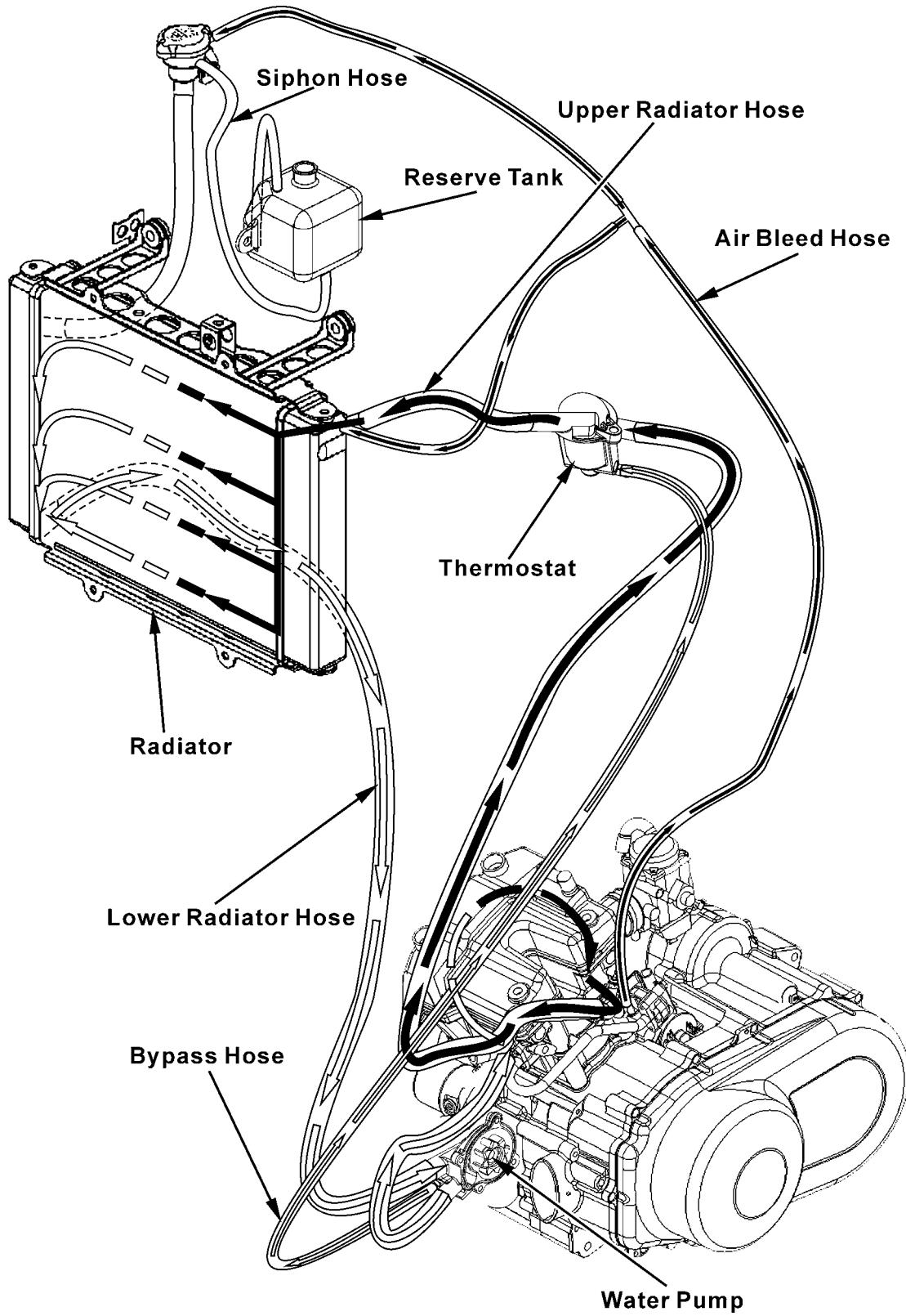

6. COOLING SYSTEM

SERVICE INFORMATION

GENERAL INSTRUCTIONS

WARNING:

Removing the radiator cap while the engine is hot can allow the coolant to spray out, seriously scalding you. Always let the engine and radiator cool down before removing the radiator cap.

CAUTION:

Radiator coolant is toxic. Keep it away from eyes, mouth, skin and clothes.

- If any coolant gets in your eyes, rinse them with water and consult a physician immediately.
- If any coolant is swallowed, induce vomiting, gargle and consult a physician immediately.
- If any coolant gets on your skin or clothes, rinse thoroughly with plenty of water.

NOTE:

Use coolant with silicate inhibitors may cause premature wear of water pump seals or blockage of radiator passages. Using tap water may cause engine damage.

- This section covers service of the cooling system.
- Add coolant at the reserve tank. Do not remove the radiator cap except to refill or drain the system.
- All cooling system services can be done with the engine in the frame.
- Avoid spilling coolant on painted surfaces.
- After servicing the system, check for leaks with a cooling system tester.

SPECIFICATIONS

| ITEM | | SPECIFICATIONS |
|--------------------------------|---------------------|---|
| Coolant capacity | Radiator and engine | 2 liter (2.1 US qt, 1.76 Imp qt) |
| | Reserve tank | 0.45 liter (0.47 US qt, 0.39 Imp qt) |
| Radiator cap relief pressure | | 90 kPa (0.9 kgf/cm ² , 12.8 psi) |
| Thermostat | Begin to open | 80 - 84°C (176 - 183°F) |
| | Fully open | 95°C (203°F) |
| | Valve lift | 8 mm (0.3 in) minimum |
| Standard coolant concentration | | 1:1 mixture with soft water |

6. COOLING SYSTEM

COOLANT GRAVITY CHART

| Temp. Coolant concentration | 0 | 5 | 10 | 15 | 20 | 25 | 30 | 35 | 40 | 45 | 50 |
|--------------------------------|-------|-------|-------|-------|-------|-------|-------|-------|-------|-------|-------|
| 5% | 1.009 | 1.009 | 1.008 | 1.008 | 1.007 | 1.006 | 1.005 | 1.003 | 1.001 | 0.009 | 0.997 |
| 10% | 1.018 | 1.107 | 1.017 | 1.016 | 1.015 | 1.014 | 0.013 | 1.011 | 1.009 | 1.007 | 1.005 |
| 15% | 1.028 | 1.027 | 1.026 | 1.025 | 1.024 | 1.022 | 1.020 | 1.018 | 1.016 | 1.014 | 1.012 |
| 20% | 1.036 | 1.035 | 1.034 | 1.033 | 1.031 | 1.029 | 1.027 | 1.025 | 1.023 | 1.021 | 1.019 |
| 25% | 1.045 | 1.044 | 1.043 | 1.042 | 1.040 | 1.038 | 1.036 | 1.034 | 1.031 | 1.028 | 1.025 |
| 30% | 1.053 | 1.051 | 1.051 | 1.049 | 1.047 | 1.045 | 1.043 | 1.041 | 1.038 | 1.035 | 1.032 |
| 35% | 1.063 | 1.062 | 1.060 | 1.058 | 1.056 | 1.054 | 1.052 | 1.049 | 1.046 | 1.043 | 1.040 |
| 40% | 1.072 | 1.070 | 1.068 | 1.066 | 1.064 | 1.062 | 1.059 | 1.056 | 1.053 | 1.050 | 1.047 |
| 45% | 1.080 | 1.078 | 1.076 | 1.074 | 1.072 | 1.069 | 1.056 | 1.063 | 1.062 | 1.057 | 1.054 |
| 50% | 1.086 | 1.084 | 1.082 | 1.080 | 1.077 | 1.074 | 1.071 | 1.068 | 1.065 | 1.062 | 1.059 |
| 55% | 1.095 | 1.093 | 1.091 | 1.088 | 1.085 | 1.082 | 1.079 | 1.076 | 1.073 | 1.070 | 1.067 |
| 60% | 1.100 | 1.098 | 1.095 | 1.092 | 1.089 | 1.086 | 1.083 | 1.080 | 1.077 | 1.074 | 1.071 |

COOLANT MIXTURE (WITH ANTI-RUST AND ANTI-FREEZING EFFECTS)

| Freezing Point | Mixing Rate | KYMCO SIGMA Coolant Concentrate | Distilled Water |
|----------------|-------------|---------------------------------|-----------------|
| -9 | 20% | | |
| -15 | 30% | 425cc | 975cc |
| -25 | 40% | | |
| -37 | 50% | | |
| -44.5 | 55% | | |

Cautions for Using Coolant:

- Use coolant of specified mixing rate. (The mixing rate of 425cc KYMCO SIGMA coolant concentrate + 975cc distilled water is 30%.)
- Do not mix coolant concentrate of different brands.
- Do not drink the coolant which is poisonous.
- The freezing point of coolant mixture shall be 5 ° lower than the freezing point of the riding area.

6. COOLING SYSTEM

TORQUE VALUES

| | |
|-----------------------|--------------------------------|
| Water pump cover bolt | 1.3 kgf-m (13 N-m, 9 lbf-ft) |
| Fan motor bolt | 0.53 kgf-m (5 N-m, 3.8 lbf-ft) |
| Fan motor switch | 1.8 kgf-m (17 N-m, 13 lbf-ft) |

TROUBLESHOOTING

Engine temperature too high

- Faulty radiator cap
- Faulty temperature gauge or thermosensor
- Air in system
- Thermostat stuck closed
- Insufficient coolant
- Passages blocked in radiator, hoses or water jacket
- Faulty cooling fan motor
- Faulty fan motor switch
- Faulty water pump

Engine temperature too low

- Faulty temperature gauge or thermosensor
- Thermostat stuck open
- Faulty fan motor switch

Coolant leak

- Faulty water pump mechanical seal
- Deteriorated O-rings
- Faulty radiator cap
- Damaged or deteriorated cylinder head gasket
- Loose hose connection or clamp
- Damaged or deteriorated hoses

6. COOLING SYSTEM

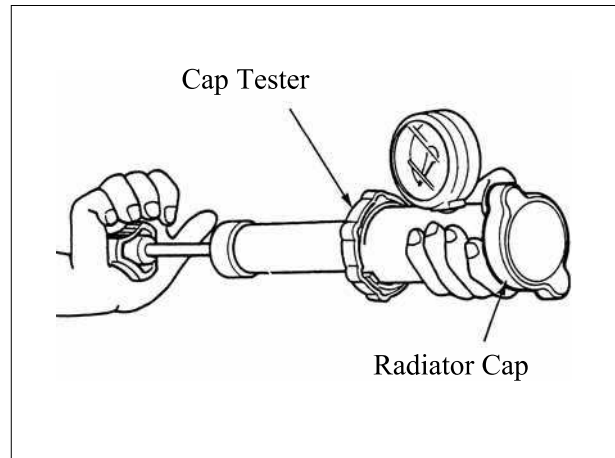

Before installing the cap in the tester, wet the sealing surface.

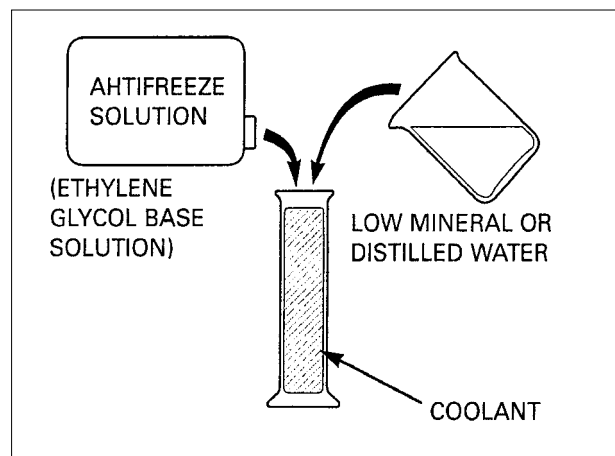
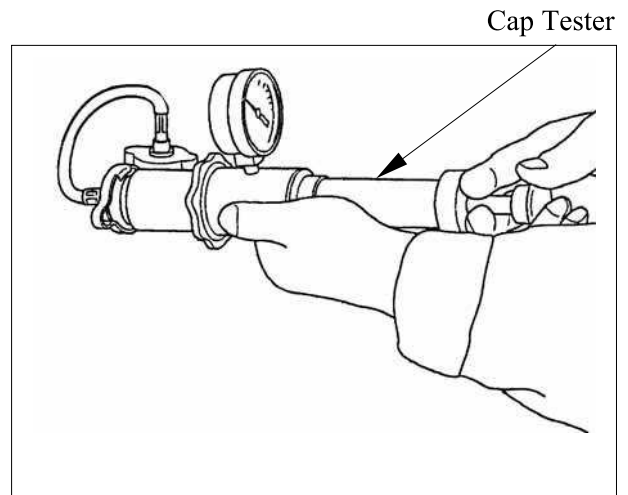

6. COOLING SYSTEM

REPLACEMENT/AIR BLEEDING

Remove the front center cover and right footboard (refer to the “**FRAME COVERS**” section in the chapter 2).

When filling the system or reserve tank with coolant (checking the coolant level), place the machine in a vertical position on a flat, level surface.

Remove the radiator cap.

Radiator Cap



Loosen the hose band

Disconnect the bypass hose from water pump or remove the drain plug and drain the coolant from the system.

Bypass Hose

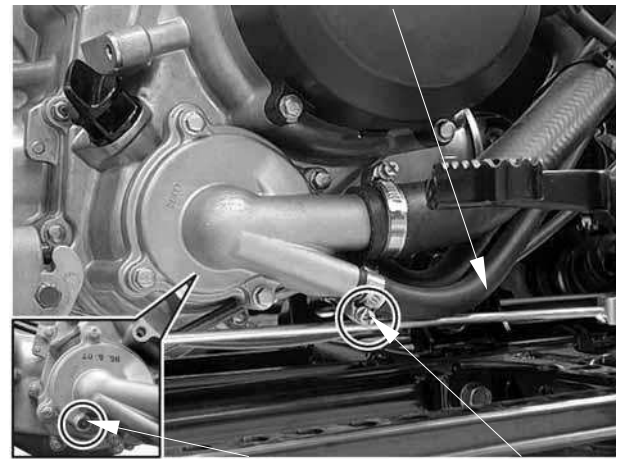

Drain Plug

Band

Remove the reserve tank cap and drain the coolant from the reserve tank.

Reconnect the bypass hose securely.

Reserve Tank Cap

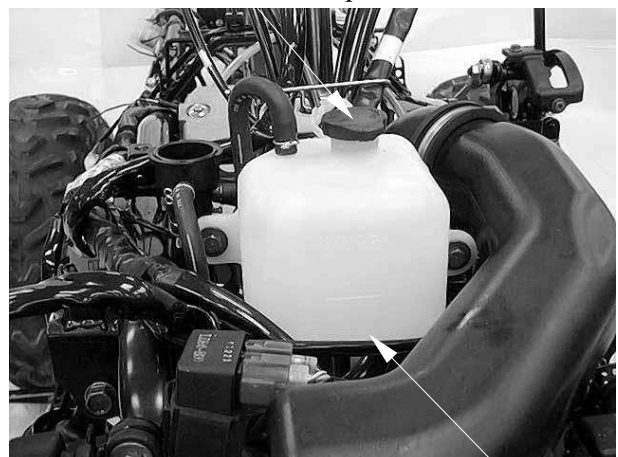

Reserve Tank

6. COOLING SYSTEM

Place the machine on a flat, level surface.
Fill the reserve tank to the upper level
(FULL) line.

Reserve Tank Cap



Fill the system with the recommended
coolant through the filler opening up to the
filler neck.

Filler Neck

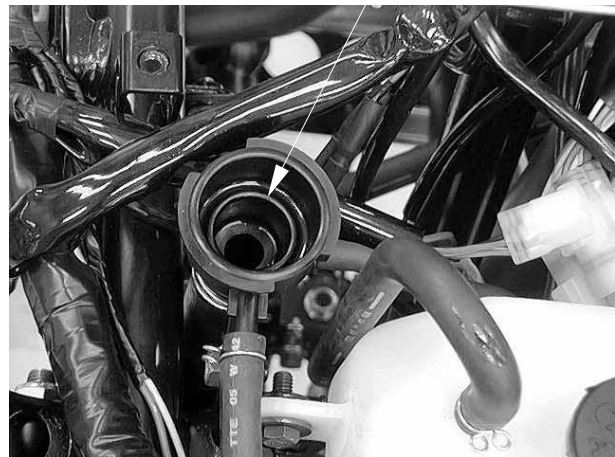

Bleed air from the system as follow:

1. Start the engine and let it idle for 2–3 minutes.
2. Snap the throttle three to four times to bleed air from the system.
3. Stop the engine and add coolant to the proper level if necessary. Reinstall the radiator cap.
4. Check the level of coolant in the reserve tank and fill to the upper level if it is low.

6. COOLING SYSTEM

THERMOSTAT

REMOVAL

Remove the nut and thermostat housing stay from the frame.

Remove the bolts, housing stay and thermostat housing cover.

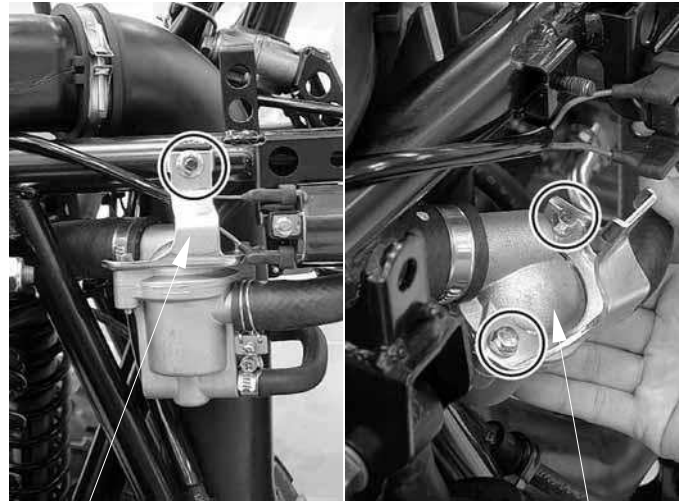

Housing stay

Thermostat Housing Cover

Remove the O-ring from the housing cover.
Remove the thermostat.

Thermostat



O-ring

Thermostat

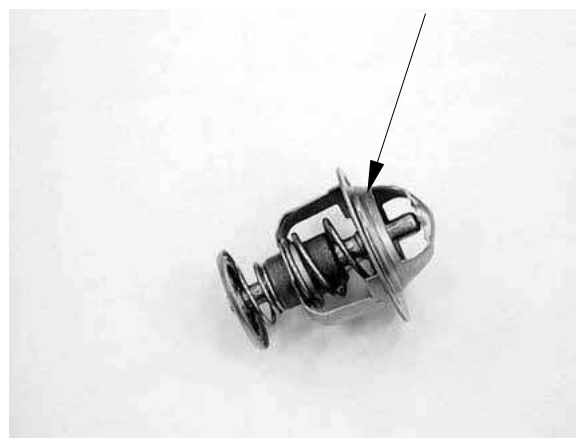

6. COOLING SYSTEM

INSPECTION

Visually inspect the thermostat for damage.

Heat the water with an electric heating element to operating temperature for five minutes.

Suspend the thermostat in heated water to check its operation.

- Keep flammable materials away from the electric heating element.
- Do not let the thermostat or thermometer touch the pan, or you will get false readings.

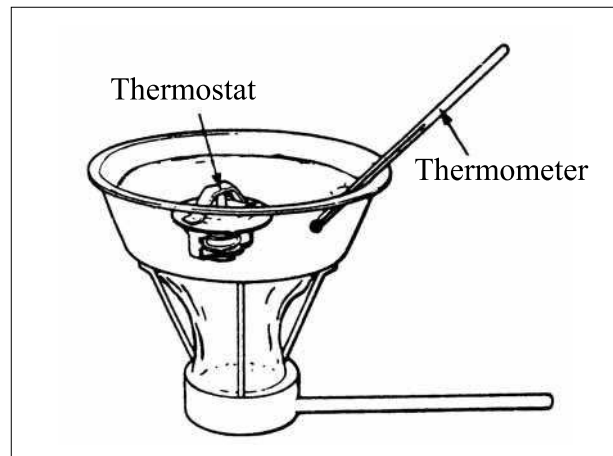

Replace the thermostat if the valve stays open at room temperature, or if it respond at temperatures other than those specified.

Thermostat begin to open:
80–84°C (176–183°F)

Valve lift:
8 mm (0.3 in) minimum at 95°C (203°F)

INSTALLATION

Install the thermostat into the housing with its air bleed hole facing up and aligning bleed hole with the tab in the housing.

Air Bleed Hole

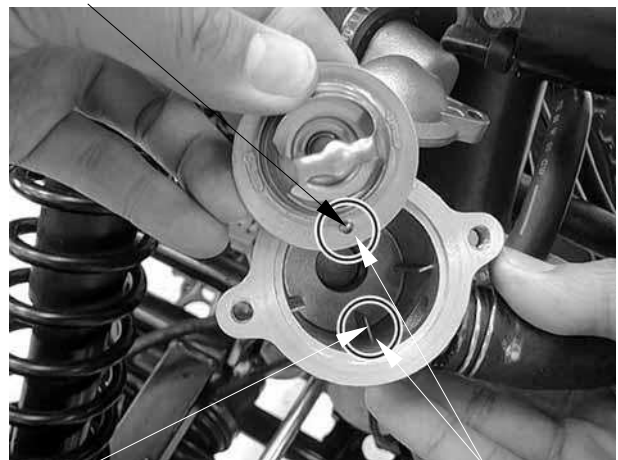

Tab

Align

6. COOLING SYSTEM

Install a new O-ring into the housing cover groove.

Install the housing cover and housing stay to the housing.
Tighten the bolts securely.

Install the housing stay to the frame.
Tighten the nut securely.

Fill the system with recommended coolant and bleed the air (refer to the “**COOLANT REPLACEMENT**” section in this chapter).



6. COOLING SYSTEM

WATER PUMP

MECHANICAL SEAL INSPECTION

Inspect the coolant leakage.

If there is leakage, the mechanical seal is defective, and water pump body should be replaced.

REMOVAL

Drain the coolant (refer to the “**COOLANT REPLACEMENT**” section in this chapter).

Loosen the hose bands and disconnect the lower radiator hoses and bypass hose from the water pump.

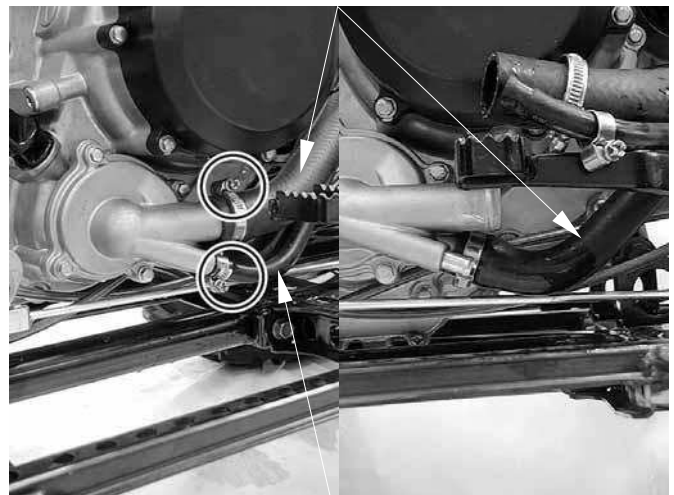

Bypass Hose

Remove the four bolts and water pump cover and O-ring.

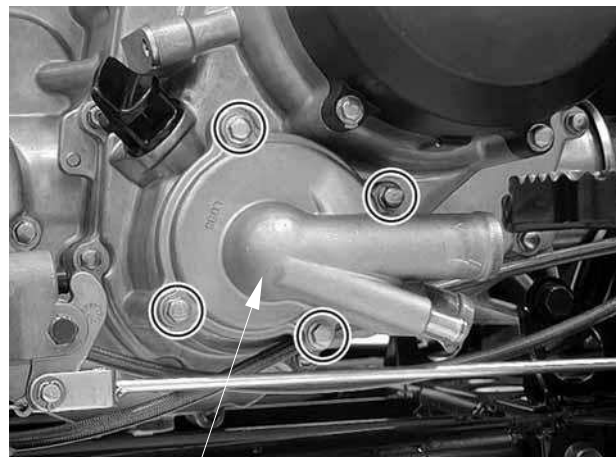

Water Pump Cover/O-ring

6. COOLING SYSTEM

Remove the water pump body from the crankcase.

Water Pump Body

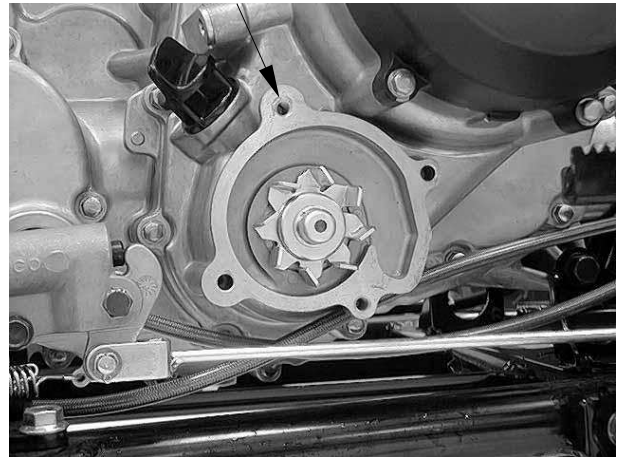

INSTALLATION

Apply engine oil to a new O-ring and install it onto the stepped portion of the water pump.

Install the water pump into the crankcase while aligning the water pump shaft groove with oil pump shaft end.

Align

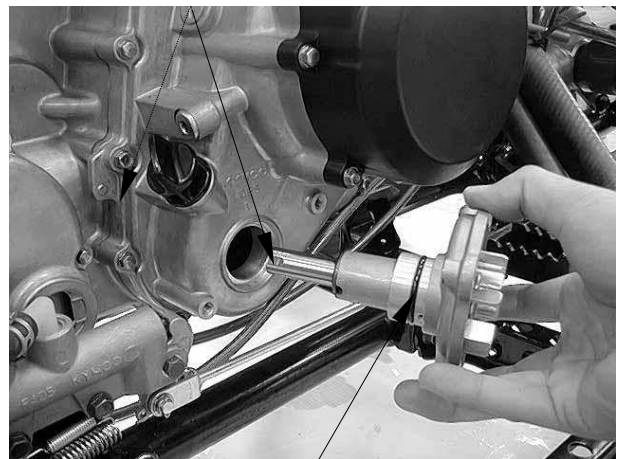

O-ring

Align the mounting bolt holes in the water pump and crankcase and make sure the water pump is securely installed.

Install a new O-ring into the groove in the water pump cover.

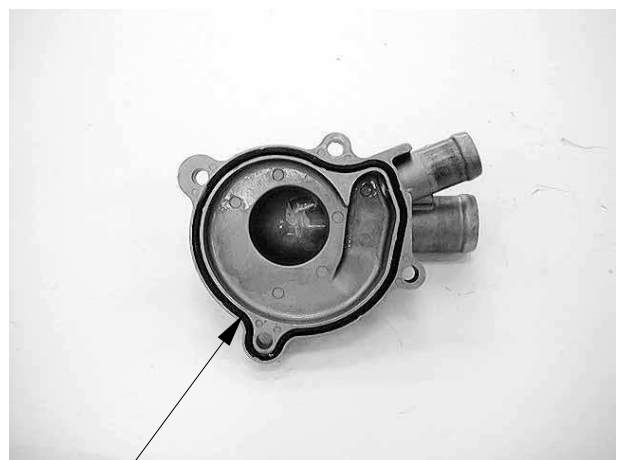

O-ring

6. COOLING SYSTEM

Install the water pump cover and tighten the bolts to the specified torque.

Torque: 1.3 kgf-m (13 N-m, 9 lbf-ft)

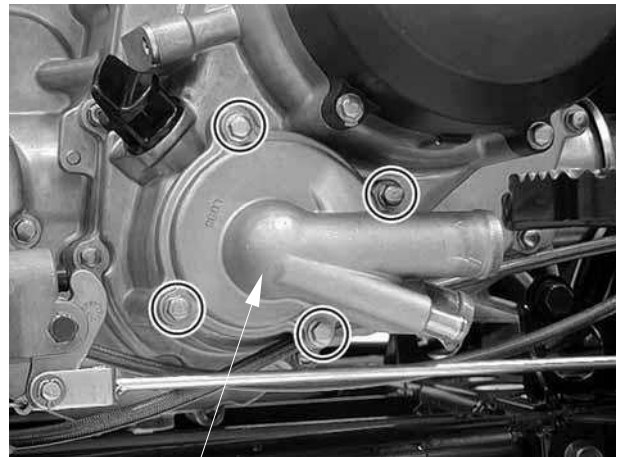

Water Pump Cover/O-ring

Connect the water hoses and bypass hose, then tighten the hose bands.

Fill the system with recommended coolant and bleed the air (refer to the “**COOLANT REPLACEMENT**” section in this chapter).

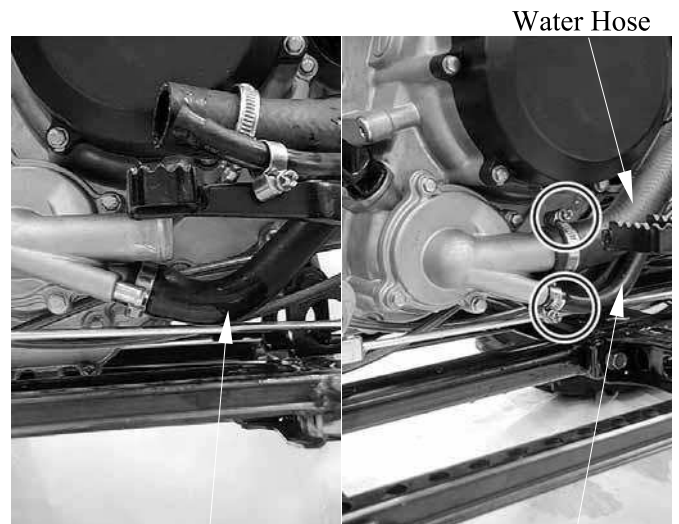

Water Hose

Bypass Hose

6. COOLING SYSTEM

RADIATOR

REMOVAL

Drain the coolant (refer to the “**COOLANT REPLACEMENT**” section in this chapter).

Remove the front fender (refer to the “**FRAME COVERS**” section in the chapter 2).

Remove the four mounting bolt from fan guide and then remove fan guide.

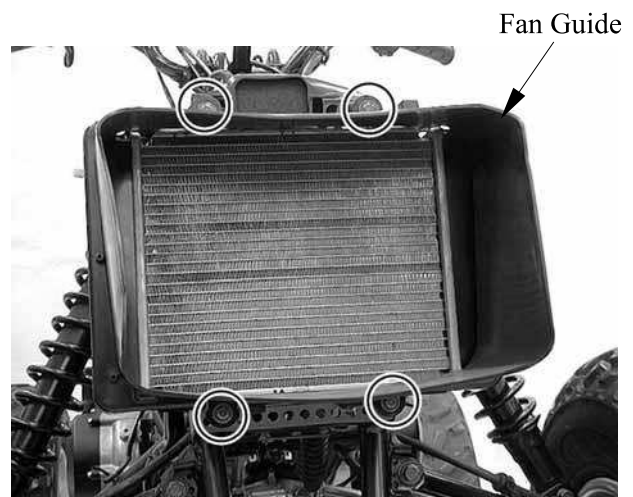

Loosen the hose bands and disconnect the radiator lower water hose, water filler hose, bleed hose and upper water hose from the radiator.

Disconnect the fan switch connectors.

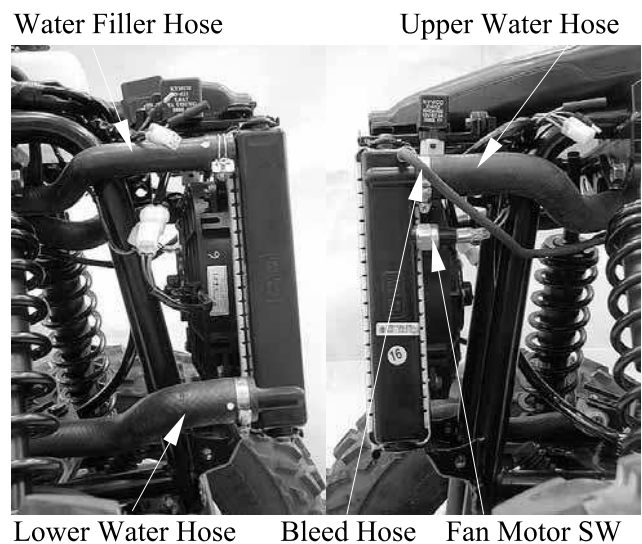

Remove the two mounting bolts under radiator and two mounting bolts on the radiator, then remove radiator.

Be careful not to damage the radiator core.

INSTALLATION

Installation is in the reverse order of removal.

Fill the system with recommended coolant and bleed the air (refer to the “**COOLANT REPLACEMENT**” section in this chapter).

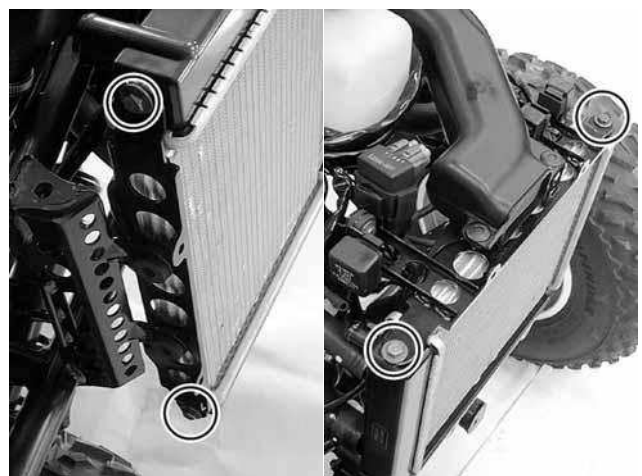

6. COOLING SYSTEM

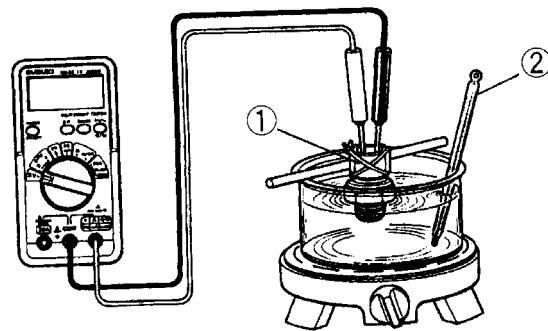
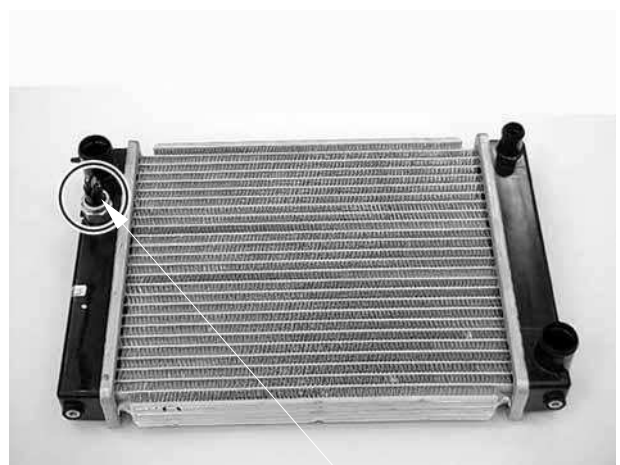

- Replace the O-ring a new one.
- Do not coat grease to the O-ring.

6. COOLING SYSTEM

FAN MOTOR

REMOVAL

Remove the front fender (refer to the “**FRAME COVERS**” section in the chapter 2)

Disconnect the fan motor connector. Remove the four mounting bolts and then remove the fan motor

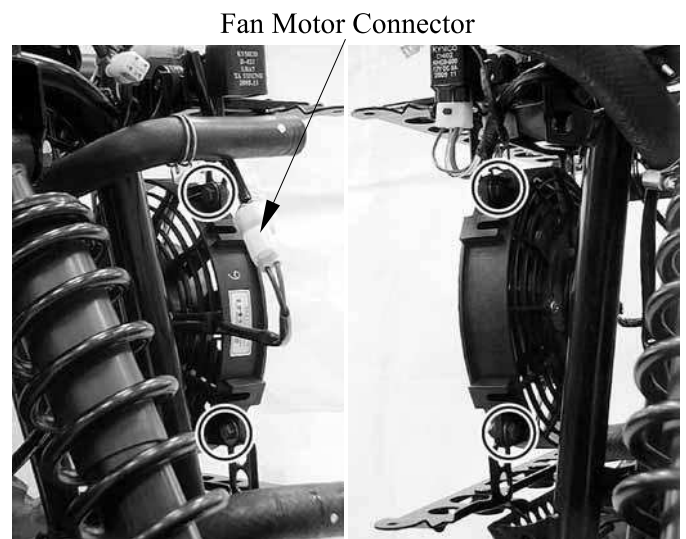

INSPECTION

Check the fan motor to operate using an available battery.

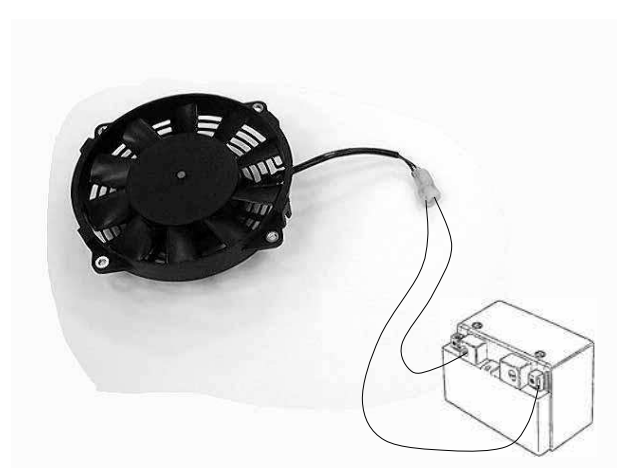

INSTALLATION

Installation is in the reverse order of removal.

6. COOLING SYSTEM

WATER TEMPERATURE SENSOR

Remove the right side body cover and right footboard (refer to the “**FRAME COVERS**” section in the chapter 2).

Disconnect the water temperature sensor connector.

Remove the water temperature sensor from the water joint.

Water Temperature Sensor

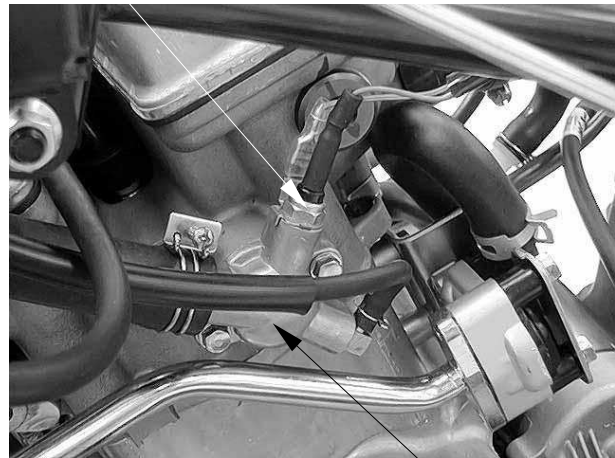

Water joint

INSPECTION

Connect the water temperature sensor to the ohmmeter and dip it in oil contained in a pan which is placed on an electric heater.

Gradually raise oil temperature while reading the thermometer in the pan and the ohmmeter connected. If the resistance measured is out of specification, replace the temperature gauge with a new one.

| Temperature | Standard resistance |
|-------------|---------------------|
| 50°C | 123.9– 478.9 Ω |
| 100°C | 26– 29.3 Ω |

- Handle the water temperature sensor carefully as it is vulnerable to impact.
- Do not allow the water temperature sensor and the thermometer to come in contact with the bottom of the pan.

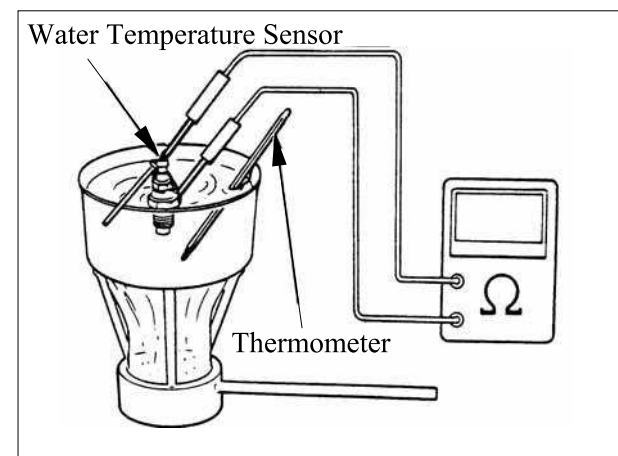

After the water temperature sensor has been installed, fill coolant and perform air bleeding (refer to the “**COOLANT REPLACEMENT**” section in this chapter).

INSTALLATION

With thread lock applied to the threaded part, tighten the water temperature sensor.

Torque: 0.8 kgf-m (8 N-m, 5.8 lbf-ft)

6. COOLING SYSTEM

RADIATOR RESERVE TANK

REMOVAL

Remove the front fender (refer to the “**FRAME COVERS**” section in the chapter 2).

Remove the two mounting bolts and then remove the radiator reserve tank from frame.

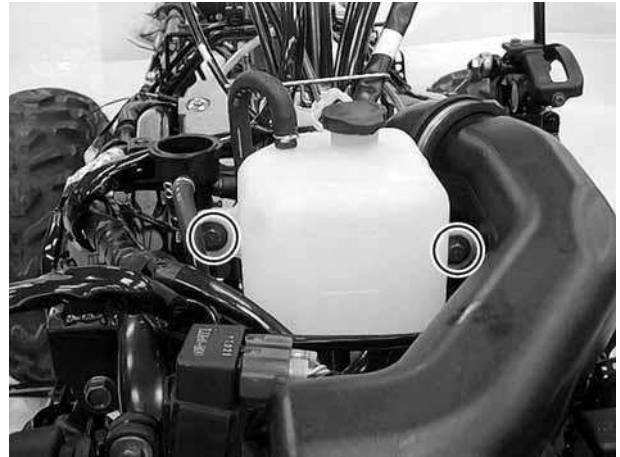

Open the reserve tank cap and drain the coolant from the reserve tank.

Disconnect the siphon hose.

INSTALLATION

Installation is in the reverse order of removal.

Pour the recommended coolant to the upper level line with the center stand applied



Siphon Hose

7. ENGINE REMOVAL/INSTALLATION

ENGINE REMOVAL

SERVICE INFORMATION----- 7- 1
ENGINE REMOVAL ----- 7- 2
ENGINE INSTALLATION ----- 7- 8



7. ENGINE REMOVAL/INSTALLATION

SERVICE INFORMATION

GENERAL INSTRUCTIONS

- A floor jack or other adjustable support is required to support and maneuver the engine.
Be careful not to damage the machine body, cables and wires during engine removal.
- Use shop towels to protect the machine body during engine removal.
- The following components require engine removal for serviced with the engine installed in the frame.
 - Oil pump (Chapter 4)
 - Water pump (Chapter 6)
 - Cylinder head (Chapter 8)
 - Cylinder/Piston (Chapter 9)
 - Drive and driven pulleys/clutch (Chapter 10)
 - Alternator/Starter clutch (Chapter 17 and 19)
- The following components require engine removal for service.
 - Transmission (Chapter 11)
 - Crankshaft/Crankcase/Balance shaft (Chapter 12)

TORQUE VALUES

| | |
|--------------------------|-------------------------------|
| Engine mounting bolt/nut | 6 kgf-m (60 N-m, 43.5 lbf-ft) |
| Engine hanger nut | 3.5 kgf-m (35 N-m, 25 lbf-ft) |

7. ENGINE REMOVAL/INSTALLATION

ENGINE REMOVAL

Drain engine oil (refer to the “ENGINE OIL” section in the chapter 3).
 Remove frame covers and exhaust pipe (refer to the “FRAME COVERS” section in the chapter 2).

Drain the engine coolant (refer to the “COOLANT REPLACEMENT” section in this chapter).

Remove the air cleaner housing and carburetor (refer to the “CARBURETOR REMOVAL/CHOKE INSPECTION/INSTALLATION” and “AIR CLEANER HOUSING” sections in the chapter 5).

Disconnect the lower water hose and bypass hose from water pump cover.
 Cut the rubber band off on the water hose.

Loosen the band screw and remove the two mounting bolts from the rear cooling duct, then remove the rear cooling duct.

Loosen the band screw and remove the fastener from the front cooling duct, then remove the front cooling duct.

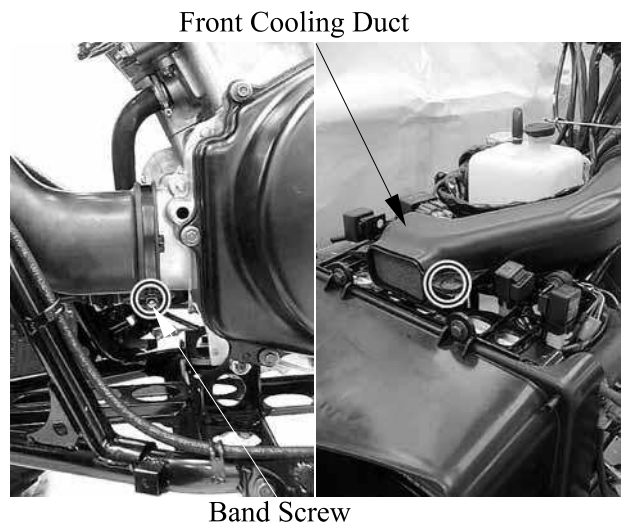
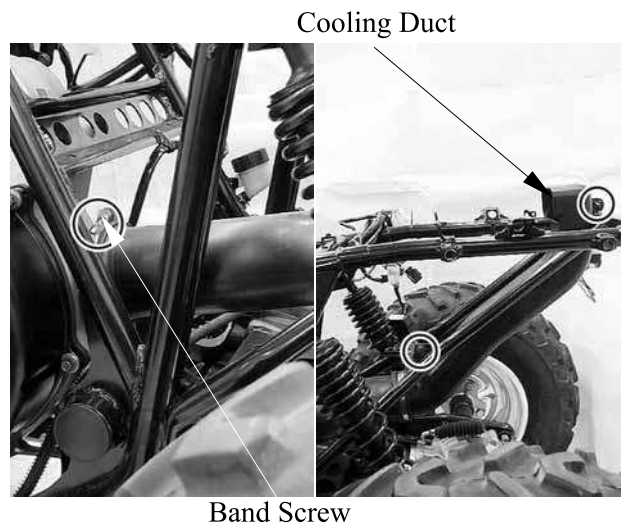
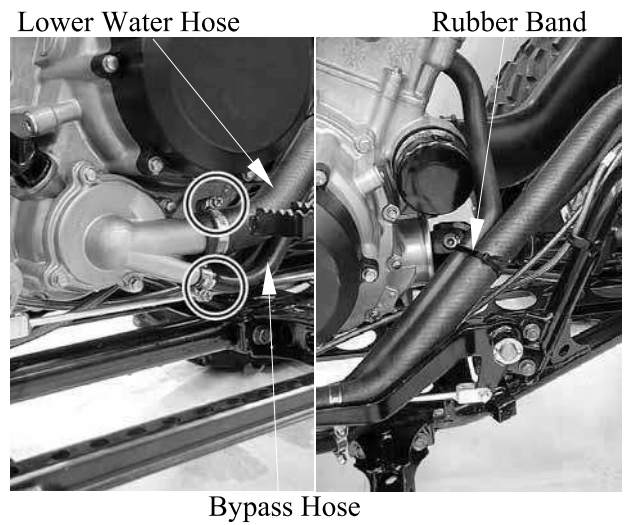

7. ENGINE REMOVAL/INSTALLATION

Disconnect the water hose, bleed hose and water temperature sensor connectors from water joint.

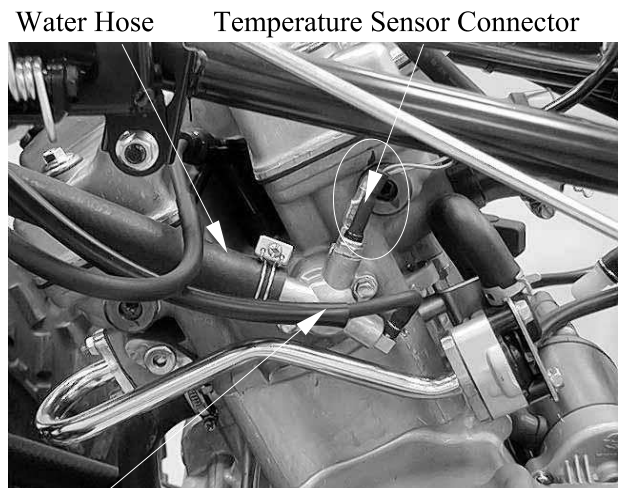

Bleed Hose

Remove the spark plug cap and disconnect the AICV air supply hose from cylinder head.



AICV Air Supply Hose

Remove the bolt/nut from drive select rod. Remove the mounting nuts from the drive select lever guide, then remove the guide and rod.



7. ENGINE REMOVAL/INSTALLATION

Disconnect the breather hose from cylinder head cover and remove the mounting nut from breather housing holder, then remove the breather housing.

Breather Hose



Disconnect the vacuum hose from intake pipe.
Slide the rubber sleeve back to expose the starter motor wire nut.
Remove the starter motor cable nut for disconnect the starter motor cable.
Remove the bolt and then disconnect the engine ground cable from starter motor.

Vacuum Hose Starter Cable

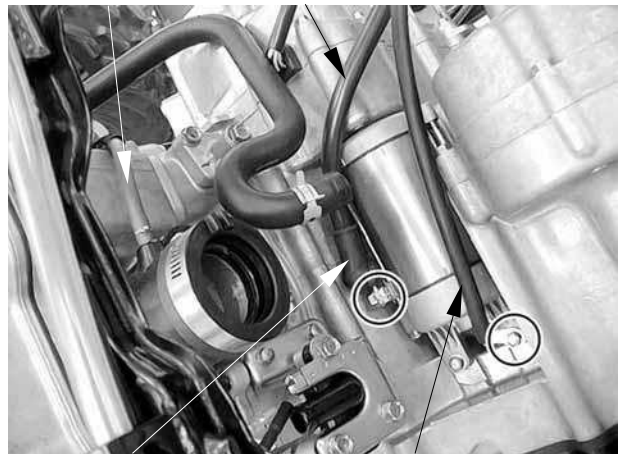

Rubber Sleeve

Engine Ground Cable

Remove the A.C. Generator and ignition pulse generator connectors.

Ignition Pulse Generator



A.C. Generator Connector

7. ENGINE REMOVAL/INSTALLATION

Disconnect the gear indicator light switch connector.

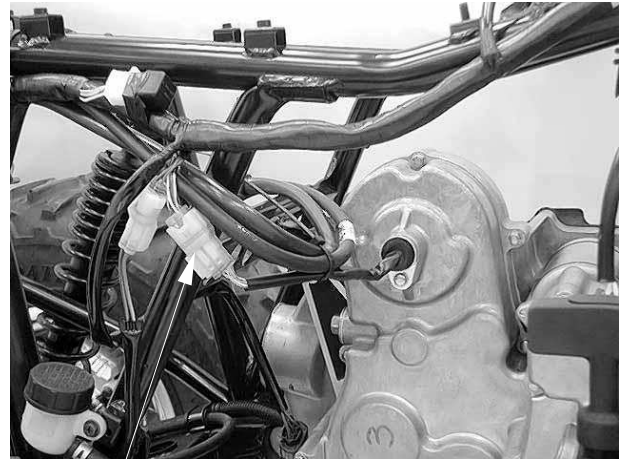

Gear Indicator Light Switch Connector

Disconnect the speed sensor connector.

Speed Sensor Connector

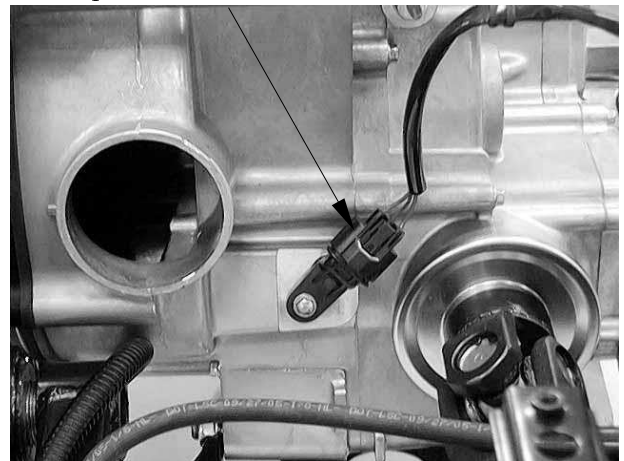

Remove the bolts and then remove the front propeller shaft from the engine assembly.

7. ENGINE REMOVAL/INSTALLATION

Remove the front lower engine mounting bolt/nut.

Remove the four nuts under right and left engine hangers, then remove the engine hangers.

Remove the rear lower engine mounting bolt/nut.

Lower Engine Mounting Bolt/Nut

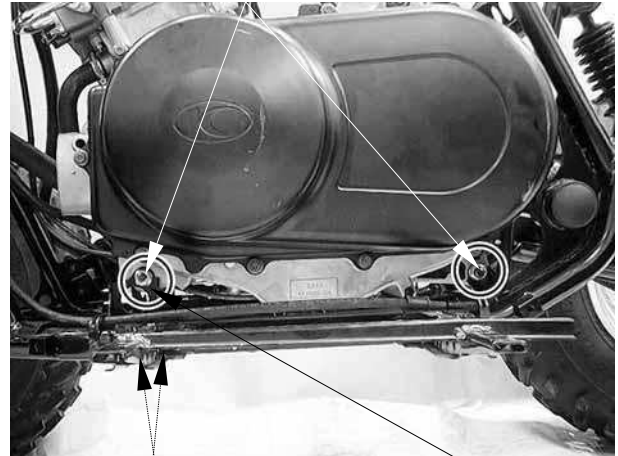

Engine Hanger Nuts

Engine Hanger

Remove the upper engine mounting bolt/nut.



Rise the engine front side and move the engine forward, then remove the engine from the frame by disengaging the rear drive gear case.

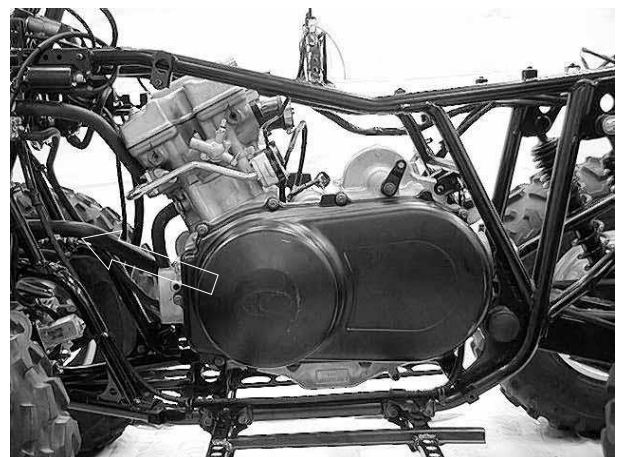

7. ENGINE REMOVAL/INSTALLATION

Tap the rear propeller shaft with rubber hammer and remove the rear propeller shaft from the engine assembly.

Take care not to lose the compression spring in the rear drive gear case end.

Lower the cylinder head and rise the engine rear side, then move the engine from the frame left side.

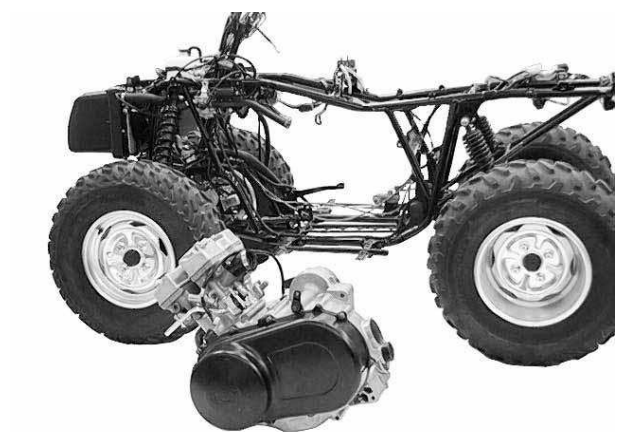

7. ENGINE REMOVAL/INSTALLATION

ENGINE INSTALLATION

Install the engine assembly into the frame.

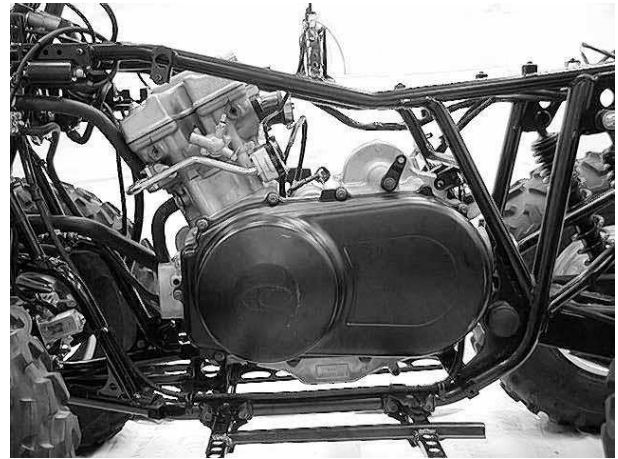

Apply lightweight lithium-soap base grease to the rear propeller shaft splines.

Install the rear propeller shaft into the engine assembly.

Apply lightweight lithium-soap base grease to the rear output shaft splines.

7. ENGINE REMOVAL/INSTALLATION

Install the compression spring into the pinion gear.

Apply lightweight lithium-soap base grease to the pinion gear splines.

Move the engine rearward and engage the rear propeller shaft into the pinion gear.

Install the joint boot securely.

Install the upper engine mounting bolt and nut loosely.



Lower Engine Mounting Bolt/Nut

Install the rear lower engine mounting bolt and nut loosely.

Install the engine hangers and four engine hanger nuts loosely.

Install the front lower engine mounting bolt and nut loosely.

Tighten the four engine hanger nuts to the specified torque.

Torque: 3.5 kgf-m (35 N-m, 25 lbf-ft)

Tighten the all engine mounting bolts and nuts to the specified torque.

Torque: 6 kgf-m (60 N-m, 43.5 lbf-ft)

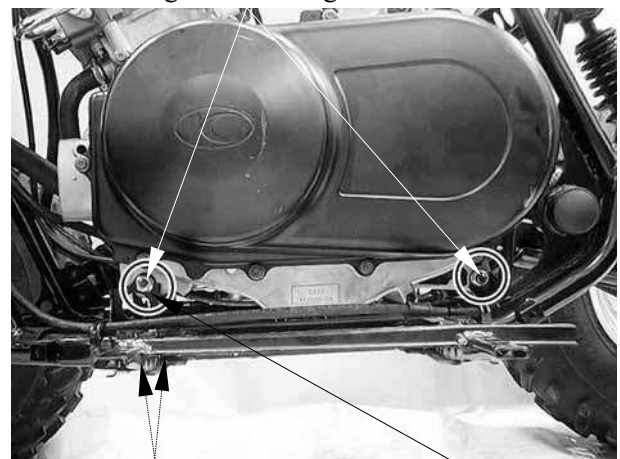

Engine Hanger Nuts

Engine Hanger

7. ENGINE REMOVAL/INSTALLATION

Apply lightweight lithium-soap base grease to the front propeller shaft splines and front output splines.

Install the front propeller shaft into the engine assembly.

Always install the bolts with the new ones.

Install the front cooling duct.

Make sure the lug on the left crankshaft case into the cutout on the front cooling duct.



7. ENGINE REMOVAL/INSTALLATION

Install the rear cooling duct.

Make sure the lug on the left crankshaft case into the cutout on the rear cooling duct.

Install the removed parts in the reverse order of removal.

Route the water hoses, wire and cable properly (refer to the “**CABLE & HARNESS ROUTING**” section in the chapter 1).

Adjusting the following items:

- Engine oil (refer to the “**ENGINE OIL**” section in the chapter 3).
- Engine coolant (refer to the “**COOLANT REPLACEMENT**” section in this chapter).



8. CYLINDER HEAD/VALVES

CYLINDER HEAD/VALVES

| | |
|--|------|
| SCHEMATIC DRAWING | 8- 1 |
| SERVICE INFORMATION..... | 8- 2 |
| TROUBLESHOOTING..... | 8- 3 |
| CYLINDER COMPRESSION TEST | 8- 4 |
| CYLINDER HEAD COVER REMOVAL/INSTALLATION..... | 8- 5 |
| CYLINDER HEAD COVER DISASSEMBLY/ASSEMBLY..... | 8- 6 |
| CAMSHAFT REMOVAL/INSPECTION/INSTALLATION | 8- 7 |
| ROCKER ARMS REMOVAL/INSPECTION/INSTALLATION ---- | 8-15 |
| CYLINDER HEAD REMOVAL/INSTALLATION..... | 8-17 |
| CYLINDER HEAD DISASSEMBLY/INSPECTION/ASSEMBLY - | 8-24 |
| CAM CHAIN REMOVAL/INSPECTION/INSTALLATION | 8-28 |

8. CYLINDER HEAD/VALVES

SCHEMATIC DRAWING

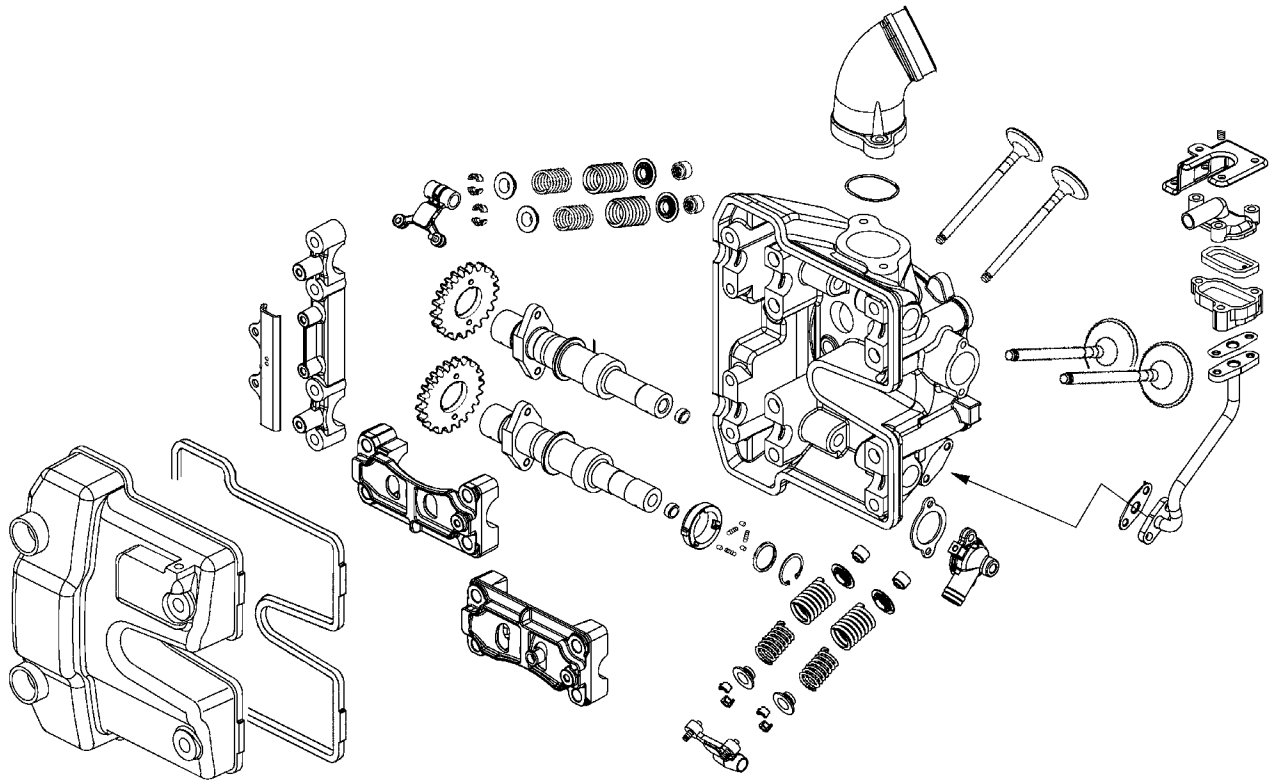

8. CYLINDER HEAD/VALVES

SERVICE INFORMATION

GENERAL INSTRUCTIONS

- The cylinder head can be serviced with the engine installed in the frame. Coolant in the radiator and water jacket must be drained first.
- When assembling, apply molybdenum disulfide grease or engine oil to the valve guide movable parts and valve arm sliding surfaces for initial lubrication.
- The valve rocker arms are lubricated by engine oil through the cylinder head engine oil passages. Clean and unclog the oil passages before assembling the cylinder head.
- After disassembly, clean the removed parts and dry them with compressed air before inspection.
- After removal, mark and arrange the removed parts in order. When assembling, install them in the reverse order of removal.

SPECIFICATIONS

Unit: mm

| Item | | Standard | Service Limit |
|------------------------------------|----|-----------------------------|---------------|
| Valve clearance (cold) | IN | 0.1 mm | — |
| | EX | 0.1 mm | — |
| Cylinder head compression pressure | | 15 kg/cm² | — |
| Cylinder head warpage | | — | 0.05 |
| Camshaft runout | | — | 0.05 |
| Camshaft cam height | IN | 37.2614 | 37.11 |
| | EX | 37.0084 | 36.86 |
| Valve rocker arm I.D. | IN | 10 ~ 10.015 | 10.1 |
| | EX | 10 ~ 10.015 | 10.1 |
| Valve rocker arm shaft O.D. | IN | 9.975 ~ 9.99 | 9.9 |
| | EX | 9.975 ~ 9.99 | 9.9 |
| Rocker arm to shaft clearance | | 0.009 ~ 0.042 | 0.1 |
| Valve stem O.D. | IN | 4.975 ~ 4.99 | 4.925 |
| | EX | 4.955 ~ 4.97 | 4.915 |
| Valve guide I.D. | IN | 5 ~ 5.015 | 5.03 |
| | EX | 5 ~ 5.015 | 5.03 |
| Valve stem-to-guide clearance | IN | 0.01 ~ 0.037 | 0.08 |
| | EX | 0.03 ~ 0.057 | 0.1 |

8. CYLINDER HEAD/VALVES

TORQUE VALUES

| | | |
|-----------------------------|--------------------|-----------------------------|
| Cylinder head bolt (1 – 4) | 4.8 kgf-m (48 N-m) | Apply engine oil to threads |
| Cylinder head bolt (5 – 13) | 2.3 kgf-m (23 N-m) | Apply engine oil to threads |
| Cylinder head nut | 1 kgf-m (10 N-m) | |
| Cylinder head cover bolt | 1 kgf-m (10 N-m) | |
| Breather separator bolt | 1.3 kgf-m (13 N-m) | |
| Cam chain tensioner bolt | 1.2 kgf-m (12 N-m) | |
| Tensioner sealing bolt | 1 kgf-m (10 N-m) | |
| Rocker arm shaft | 4.5 kgf-m (45 N-m) | |
| Cam chain guide pivot bolt | 2 kgf-m (20 N-m) | |
| Water joint bolt | 1.2 kgf-m (12 N-m) | |

SPECIAL TOOLS

| | |
|-------------------------|------------|
| Valve spring compressor | A120E00040 |
|-------------------------|------------|

TROUBLESHOOTING

- The poor cylinder head operation can be diagnosed by a compression test or by tracing engine top-end noises.

Poor performance at idle speed

- Compression too low

Compression too low

- Incorrect valve clearance adjustment
- Burned or bent valves
- Incorrect valve timing
- Broken valve spring
- Poor valve and seat contact
- Leaking cylinder head gasket
- Warped or cracked cylinder head
- Poorly installed spark plug

Compression too high

- Excessive carbon build-up in combustion chamber

White smoke from exhaust muffler

- Worn valve stem or valve guide
- Damaged valve stem oil seal

Abnormal noise

- Incorrect valve clearance adjustment
- Sticking valve or broken valve spring
- Damaged or worn camshaft
- Worn cam chain tensioner
- Worn camshaft and rocker arm

8. CYLINDER HEAD/VALVES

CYLINDER COMPRESSION TEST

Warm up the engine to normal operating temperature.
Stop the engine and remove the spark plug cap and remove the spark plug (refer to the “SPARK PLUG” section in the chapter 3).

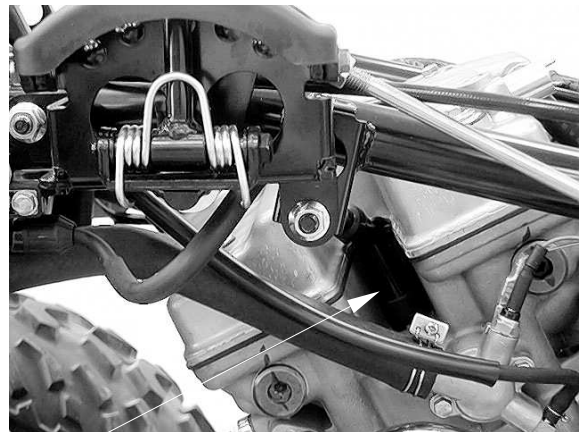

Park Plug Cap

Install a compression gauge into the spark plug hole.

Open the throttle all the way and crank the engine with the starter motor until the gauge reading stops rising.

The maximum reading is usually reached 4 – 7 seconds.

* To avoid discharging the battery, do not operate the starter motor for more than seven seconds.

Compression Gauge

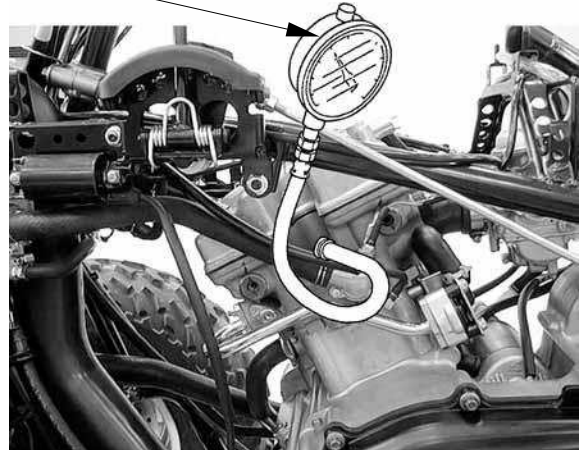

Compression pressure:

15 kg/cm² (1500 kPa, 213 psi)

Low compression can be caused by:

- ♦ Blown cylinder head gasket
- ♦ Improper valve adjustment
- ♦ Valve leakage
- ♦ Worn piston ring or cylinder

High compression can be caused by:

- ♦ Carbon deposits in combustion chamber or on piston head

8. CYLINDER HEAD/VALVES

CYLINDER HEAD COVER REMOVAL/INSTALLATION

REMOVAL

Disconnect the crankcase breather hose from the cylinder head cover (refer to the “ENGINE REMOVAL” section in the chapter 7).

Remove the four bolts/rubber washers and cylinder head cover.

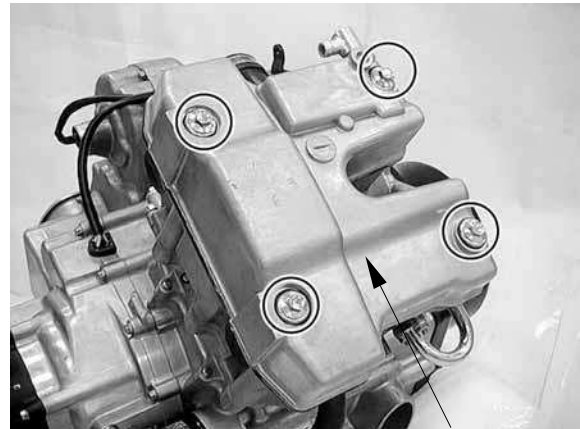

Cylinder Head Cover

Remove the cylinder head cover packing.

INSTALLATION

Apply fluid gasket (threebond: 1215) to the mating surface of the cylinder head cover, then install the packing.

Cylinder Head Cover Packing



Install the cylinder head cover.
Install and tighten the four bolts/rubber washers to the specified torque in a crisscross pattern.

Torque: 1 kgf-m (10 N-m)

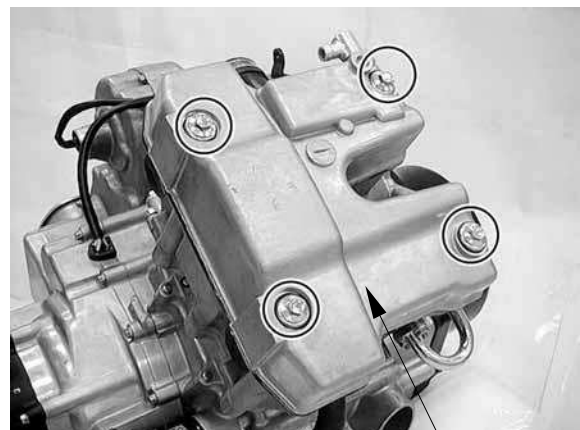

Cylinder Head Cover

8. CYLINDER HEAD/VALVES

CYLINDER HEAD COVER DISASSEMBLY/ASSEMBLY

DISASSEMBLY

Remove the three bolts and breather separator.



Remove the gasket.

ASSEMBLY

Assembly is in the reverse order of disassembly.

Torque:

Breather separator bolt:

1.3 kgf-m (13 N-m,)



8. CYLINDER HEAD/VALVES

CAMSHAFT REMOVAL/INSPECTION/ INSTALLATION

REMOVAL

Remove the cylinder head cover (refer to the “**CYLINDER HEAD COVER REMOVAL/INSTALLATION**” section in this chapter).

Turn the crankshaft clockwise and align the “T” mark on the flywheel with the index mark on the right crankcase cover (refer to the “**VALVE CLEARANCE**” section in the chapter 3).

Remove the cam chain tensioner lifter sealing bolt, spring and sealing washer.

Remove the two bolts, cam chain tensioner and gasket.

Remove the two bolts and cam chain guide.

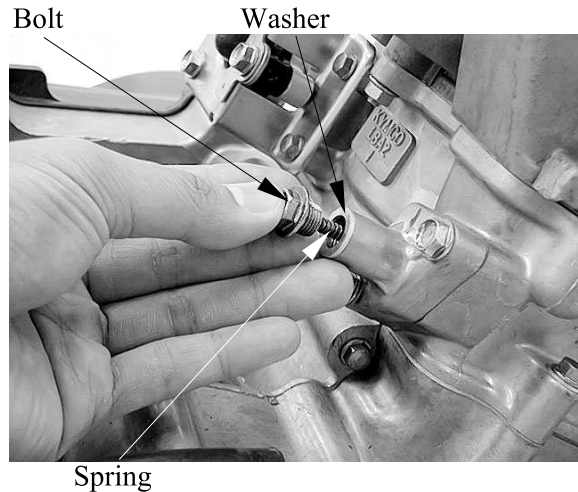

Cam Chain Tensioner/Gasket



Cam Chain Guide

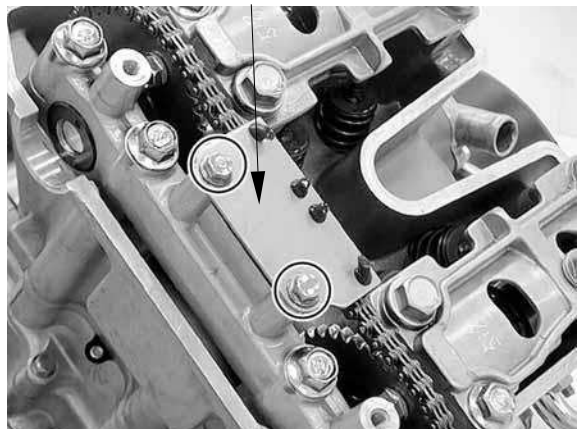

8. CYLINDER HEAD/VALVES

Loosen and remove the eight camshaft holder bolts in a crisscross pattern in several steps.

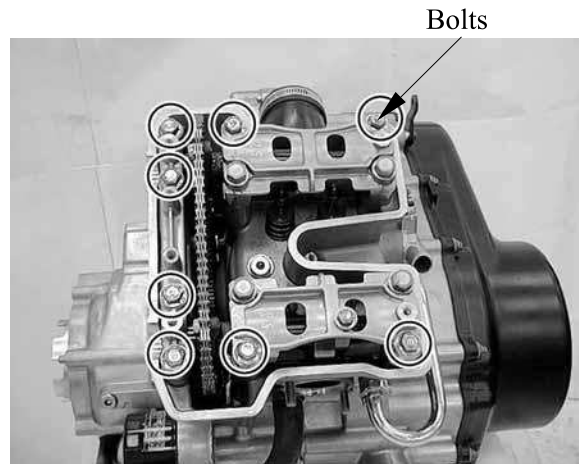

Loosen and remove the four camshaft holder bolts/washers in a crisscross pattern in several steps, then remove the camshaft holders.

* Suspend the cam chain with a piece of wire to prevent the chain from falling into the crankcase.

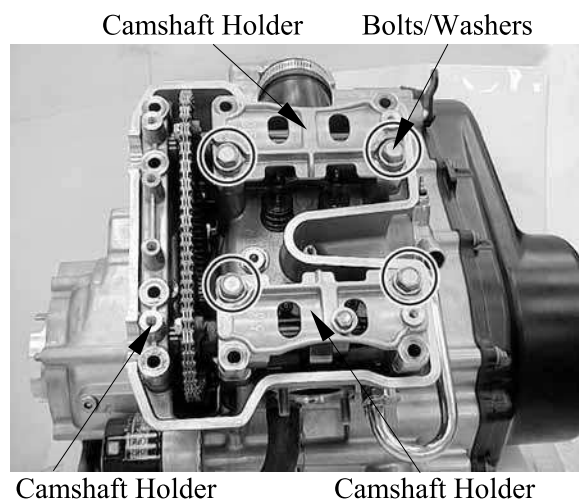

Remove the camshafts.

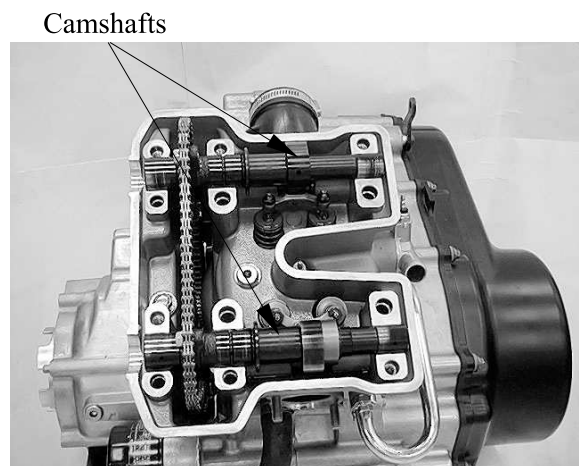

8. CYLINDER HEAD/VALVES

INSPECTION

Cam chain guide

Inspect the cam chain slipper surface of the cam chain guide for wear or damage.

Cam Chain Slipper



Camshaft holder

* Always replace the camshaft holder and cylinder head in pairs

Inspect the camshaft surface of each camshaft holder for scoring, scratches, or evidence of insufficient lubrication.

Camshaft Holders

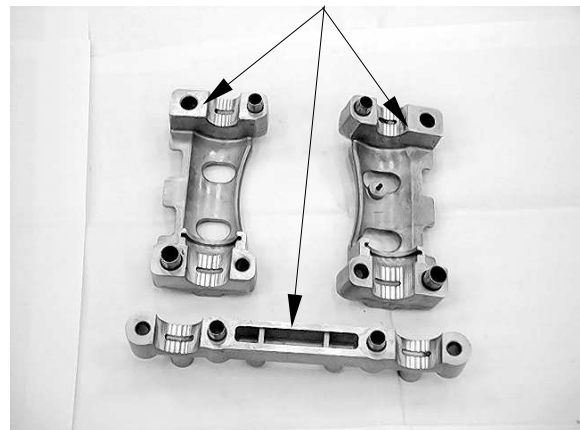

Check the stop pin spring on the exhaust camshaft holder for damage.

Replace the stop pin assembly with a new one if the spring is damaged.

Stop Pin

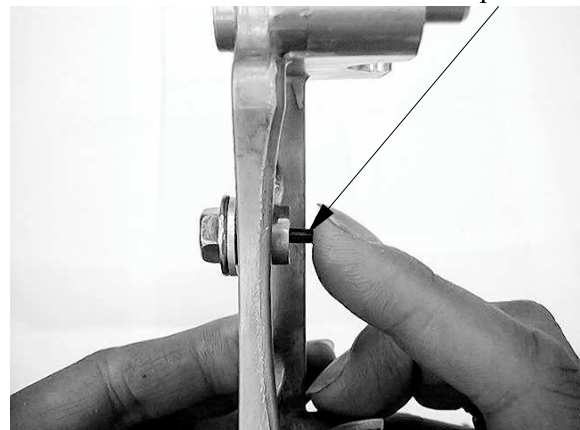

8. CYLINDER HEAD/VALVES

Camshaft

Support both ends of the camshaft with V-blocks and check the camshaft runout with a dial gauge.

Service limit: 0.05 mm

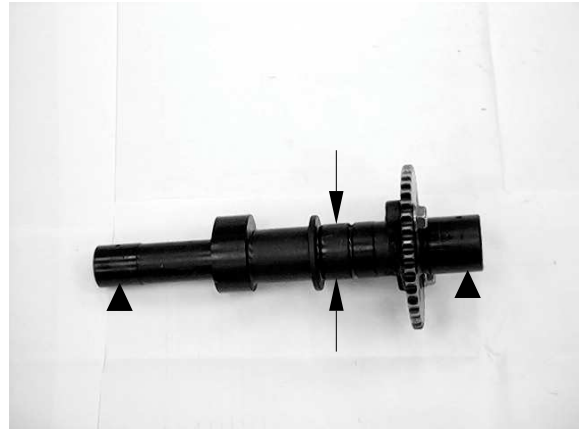

Inspect camshaft lobes for pitting/scratches/blue discoloration.

Measure the cam lobe height.

Service Limits: IN : 37.11 mm
EX: 36.86 mm

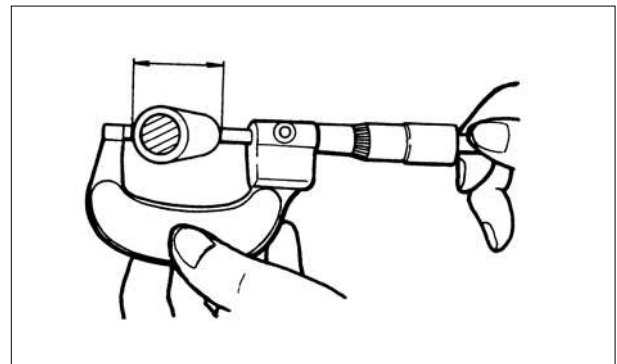

If any defects are found, replace the camshaft with a new one, then inspect lubrication system.

Check the decompression system by turning the decompressor cam on the exhaust camshaft. You should be able to turn the decompressor cam clockwise smoothly, but the decompressor should not turn counterclockwise.



8. CYLINDER HEAD/VALVES

Cam chain tensioner

Check the one-way cam operation (tensioner)
Unsmooth operation → Replace.

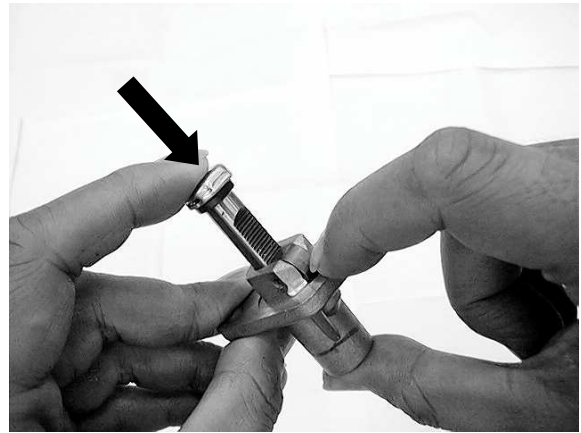

INSTALLATION

Turn the crankshaft clockwise, align the “T” mark on the flywheel with the index mark on the right crankcase cover (refer to the “VALVE CLEARANCE” in chapter 3).

Apply molybdenum disulfide oil to the camshaft journals of the camshaft holder.

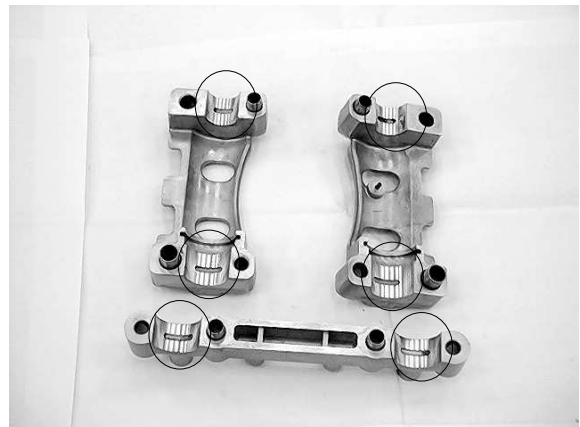

Apply molybdenum disulfide oil to the camshaft journals of the cylinder head.

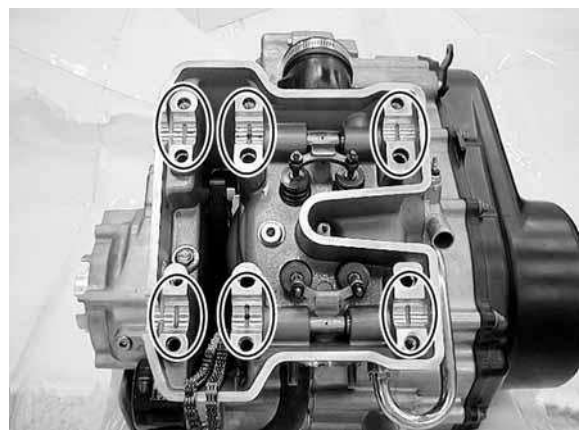

8. CYLINDER HEAD/VALVES

Install the cam chain over the cam sprockets and then install the intake and exhaust camshafts.

*

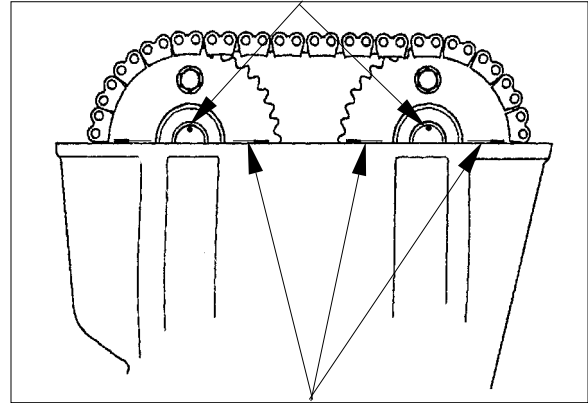

Install intake and exhaust camshaft holders to the correct locations.

*

Install each camshaft holders to the correct locations.
“IN”: no stop pin.
“EX”: has a stop pin.

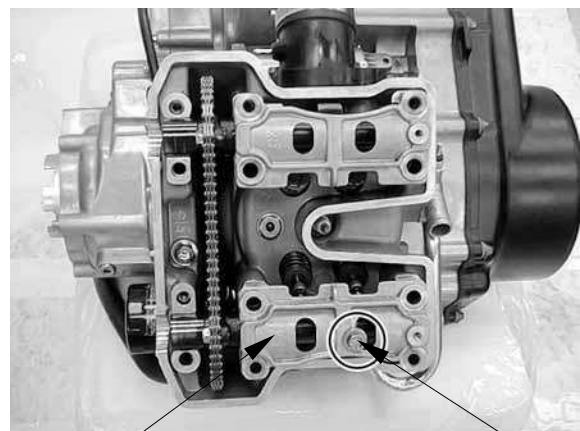

Exhaust Camshaft Holder

Stop Pin

8. CYLINDER HEAD/VALVES

Apply engine oil to cylinder head bolt (No. 1 – 8) threads.

Install the four bolts (No. 5 – 8).

Install the four bolts/washers (No. 1 – 4).

Tighten the holder bolts (No. 1 – 8) in a crisscross pattern in five steps to the specified torque as follow diagram.

| Tighten the bolts to the specified torque in sequence | | | | | | | | | |
|---|--------------|-----|-----|-----|--------------|-----|-----|-----|--|
| kgf-m (N-m, lbf-ft) | | | | | | | | | |
| | (1) | (2) | (3) | (4) | (5) | (6) | (7) | (8) | |
| Step 1 | 2.4 (24, 17) | ← | ← | ← | 1.2 (12, 9) | ← | ← | ← | |
| Step 2 | 3.8 (38, 27) | ← | ← | ← | 2.3 (23, 17) | ← | ← | ← | |
| Step 3 | 4.8 (48, 35) | ← | ← | ← | | | | | |

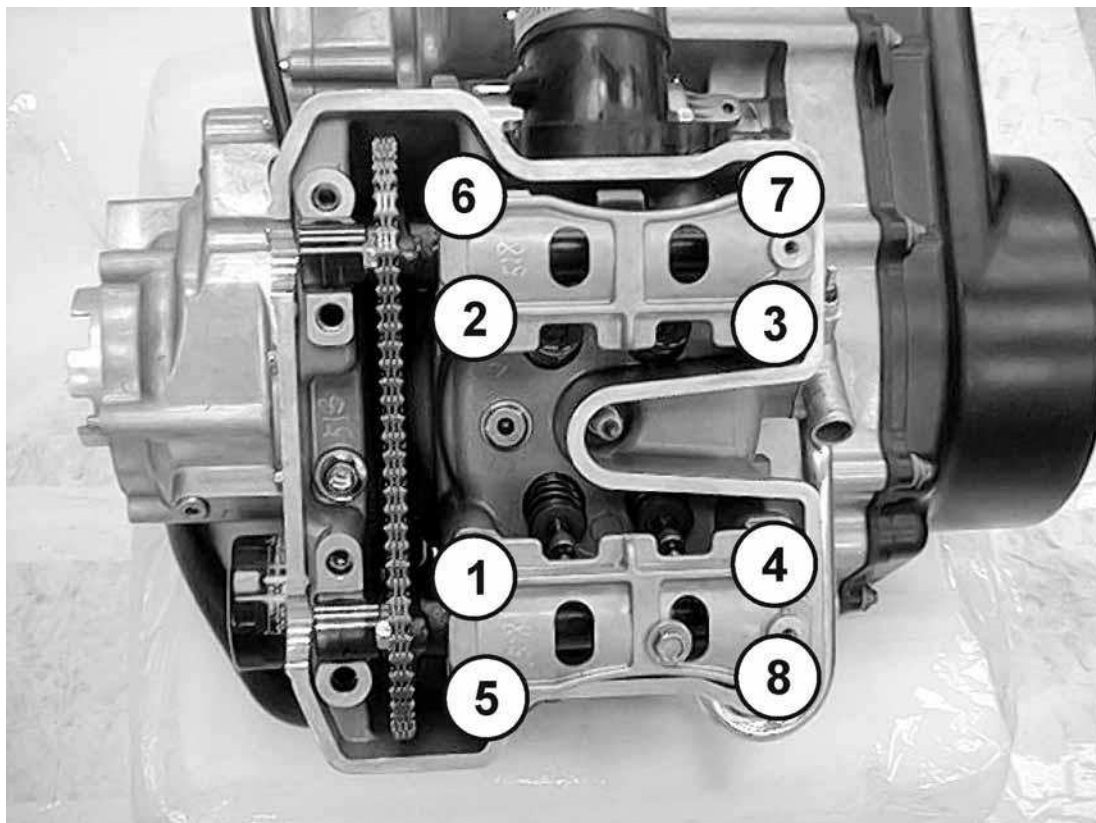

8. CYLINDER HEAD/VALVES

Apply engine oil to cylinder head bolt (No. 10 – 13) threads.

Install the common camshaft holder by arrow mark facing outside.

Install and tighten the holder bolts (No. 10 – 13) in a crisscross pattern in five steps to the specified torque as follow diagram.

| Tighten the bolts to the specified torque in sequence | | | | | | | | |
|---|----------|------|------|------|--|--|--|--|
| kgf-m (N-m) | | | | | | | | |
| | (10) | (11) | (12) | (13) | | | | |
| Step 4 | 1.2 (12) | ← | ← | ← | | | | |
| Step 5 | 2.3 (23) | ← | ← | ← | | | | |

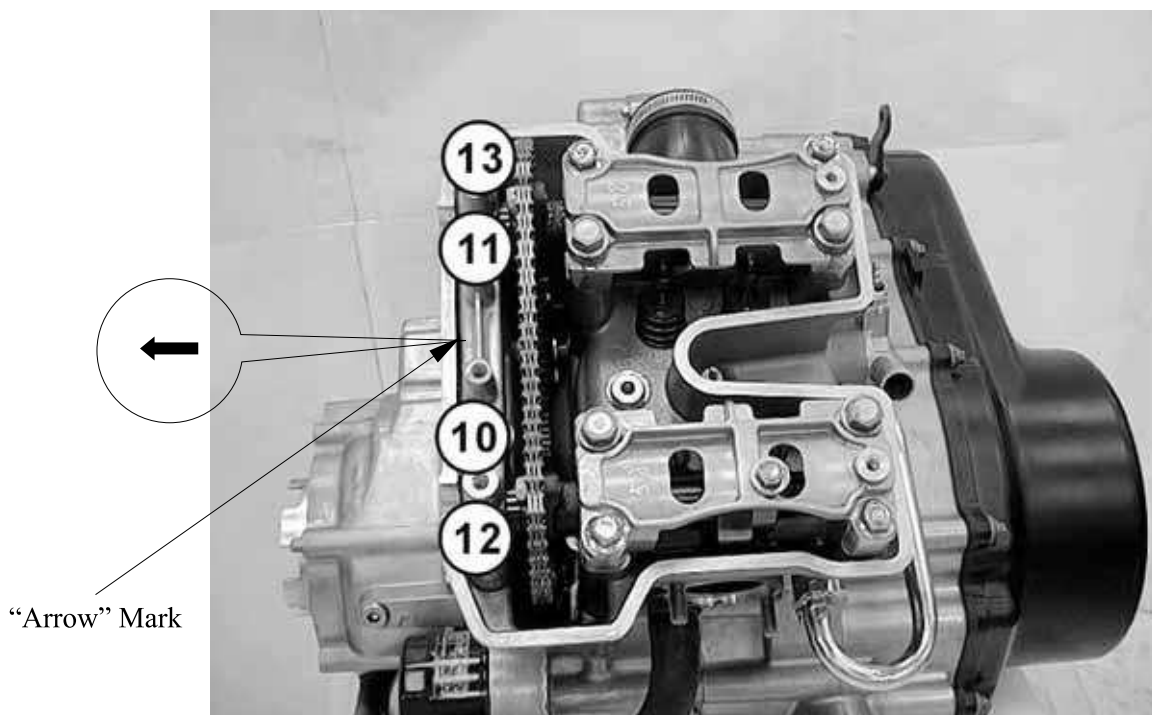

8. CYLINDER HEAD/VALVES

ROCKER ARMS REMOVAL/INSPECTION/ INSTALLATION

REMOVAL

Remove the camshafts (refer to the “CAMSHAFT REMOVAL/INSPECTION/INSTALLATION” section in this chapter).

Remove the rocker arm shafts and washers, then remove the rocker arms.

Rocker Arms

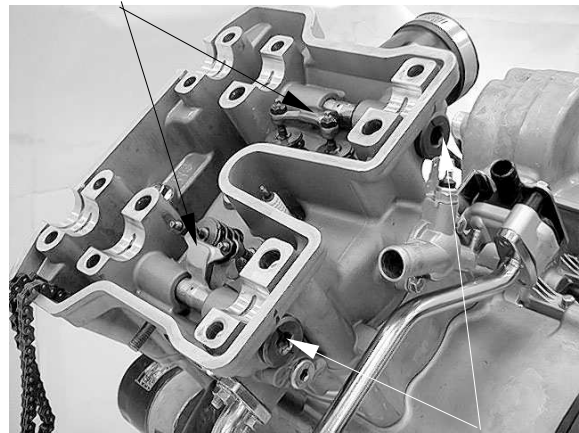

Rocker Arm Shafts/Washers

INSPECTION

Rocker arm shaft

Inspect the rocker arm shaft for blue discoloration or grooves.

If any defects are found, replace the rocker arm shaft with a new one, then inspect lubrication system.

Measure each rocker arm shaft O.D.

Measure the I.D. of each rocker arm.

Measure arm to shaft clearance.

Replace as a set if out of specification.

Service limits: 0.1 mm

Inspect the rocker arm bore, cam lobe contact surface and adjuster surface for wear/pitting/scratches/blue discoloration.

If any defects are found, replace the rocker arm shaft with a new one, then inspect lubrication system.

Measure each rocker arm shaft O.D.

Measure the I.D. of each rocker arm.

Measure arm to shaft clearance.

Replace as a set if out of specification.

Service limits: 0.1 mm

Rocker Arm Shaft



Rock Arm

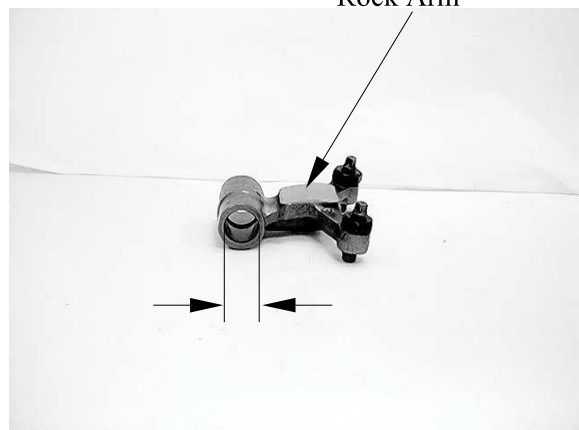

8. CYLINDER HEAD/VALVES

INSTALLATION

Apply engine oil to the rocker arms and rocker arm shafts

Install the rocker arms, rocker arm shafts and washers.
Tighten the rocker arm shaft to the specified torque.

Torque: 4.5 kgf-m (45 N-m, 32 lbf-ft)

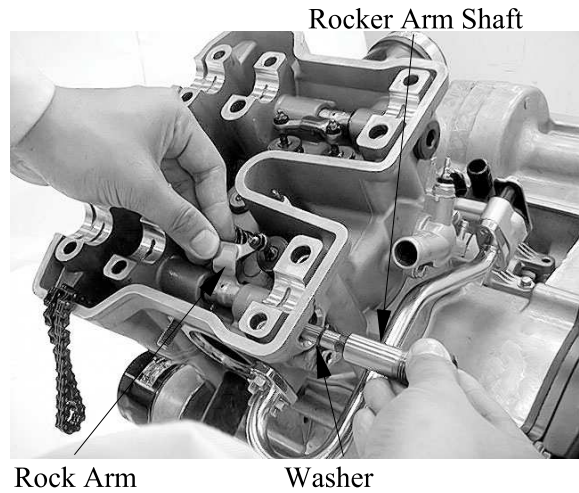

8. CYLINDER HEAD/VALVES

CYLINDER HEAD REMOVAL/INSTALLATION

* Always replace the camshaft holder and cylinder head in pairs

Remove the camshafts (refer to the “CAMSHAFT REMOVAL/INSPECTION/INSTALLATION” section in this chapter)

Remove the two bolts and intake pipe.

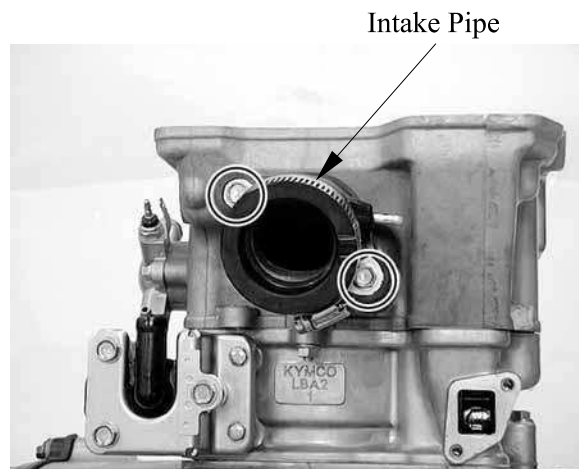

Remove the five bolts, then remove the pair reed valve cover and holder.

Remove the two nuts, then remove the pair reed valve and gasket.

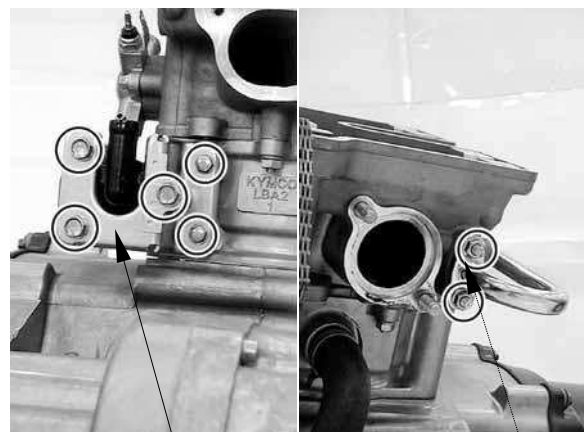

Pair Reed Valve Cover/Holder

Gasket

Remove the two bolts, water joint, gasket and water stop collar.



Water Joint/Gasket/Water Stop Collar

8. CYLINDER HEAD/VALVES

Remove the two nuts under the cylinder head.

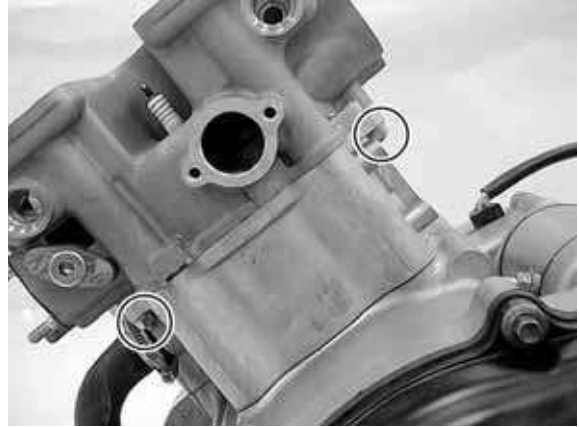

Remove the bolt and then remove the cylinder head.

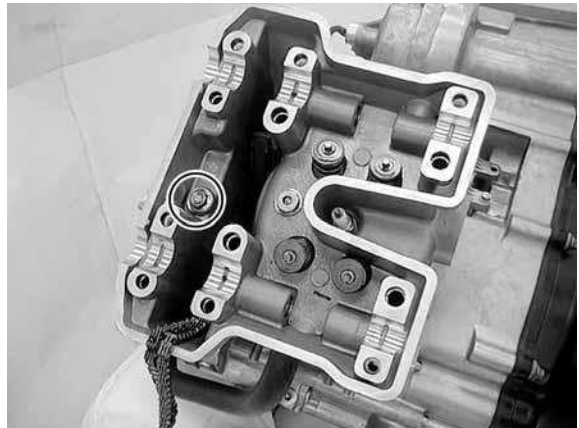

Remove the dowel pins and gasket.

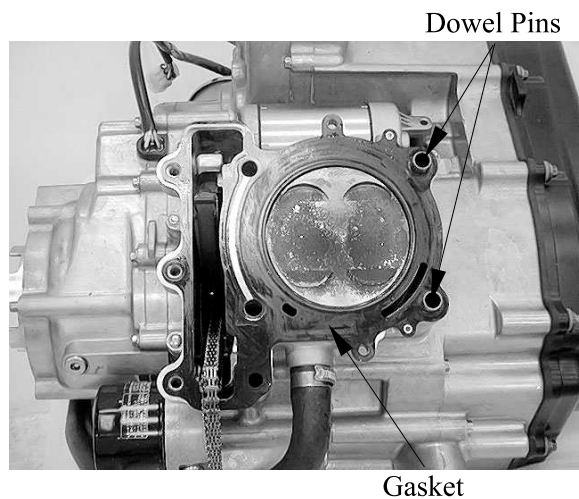

8. CYLINDER HEAD/VALVES

INSTALLATION

Install the dowel pins and new gasket as shown.

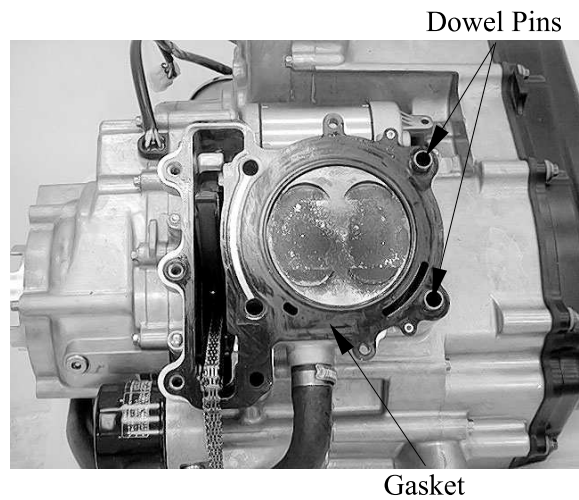

Install the cylinder head.

Apply engine oil to the cylinder head bolt (9) threads.

Install the bolt (9) but do not tighten it.



Install the camshafts, intake camshaft holder and exhaust camshaft holder (refer to the “CAMSHAFT REMOVAL/INSPECTION/INSTALLATION” section in this chapter).

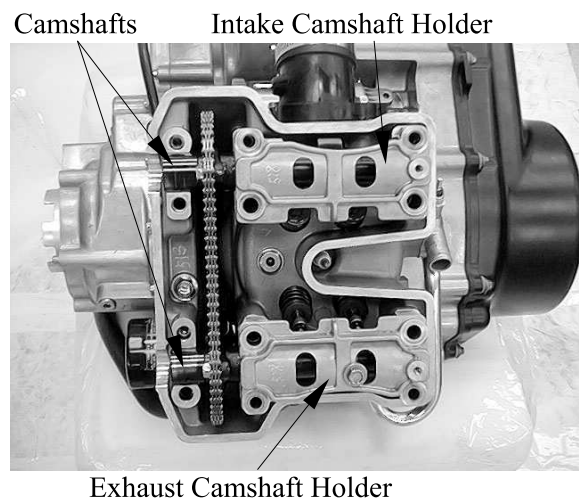

8. CYLINDER HEAD/VALVES

Apply engine oil to cylinder head bolt (No. 1 – 8) threads.

Install the four bolts (No. 5 – 8).

Install the four bolts/washers (No. 1 – 4).

Tighten the holder bolts (No. 1 – 9) in a crisscross pattern in five steps to the specified torque as follow diagram.

| Tighten the bolts to the specified torque in sequence | | | | | | | | | |
|---|----------|-----|-----|-----|----------|-----|-----|-----|-----|
| kgf-m (N-m) | | | | | | | | | |
| | (1) | (2) | (3) | (4) | (5) | (6) | (7) | (8) | (9) |
| Step 1 | 2.4 (24) | ← | ← | ← | 1.2 (12) | ← | ← | ← | ← |
| Step 2 | 3.8 (38) | ← | ← | ← | 2.3 (23) | ← | ← | ← | ← |
| Step 3 | 4.8 (48) | ← | ← | ← | | | | | |

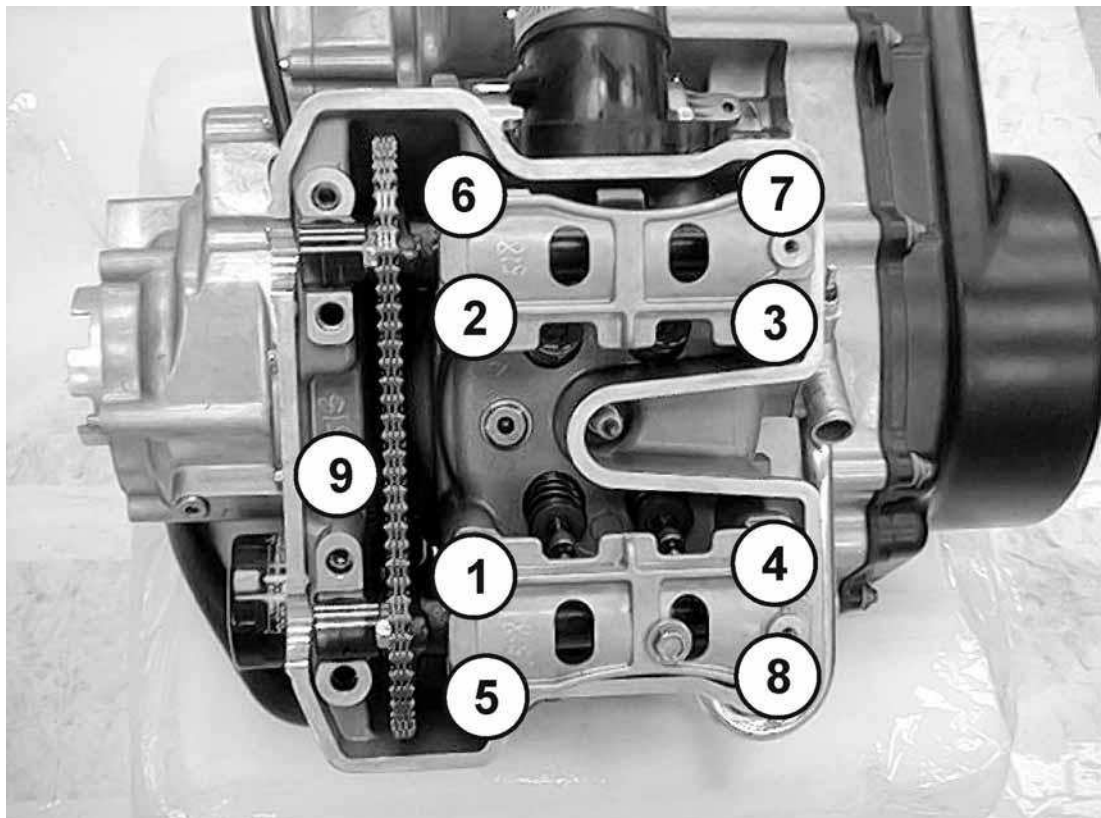

8. CYLINDER HEAD/VALVES

Apply engine oil to cylinder head bolt (No. 10 – 13) threads.

Install the common camshaft holder by arrow mark facing outside.

Install and tighten the holder bolts (No. 10 – 13) in a crisscross pattern in five steps to the specified torque as follow diagram.

| Tighten the bolts to the specified torque in sequence | | | | | | | | |
|---|--------------|------|------|------|--|--|--|--|
| kgf-m (N-m, lbf-ft) | | | | | | | | |
| | (10) | (11) | (12) | (13) | | | | |
| Step 4 | 1.2 (12, 9) | ← | ← | ← | | | | |
| Step 5 | 2.3 (23, 17) | ← | ← | ← | | | | |

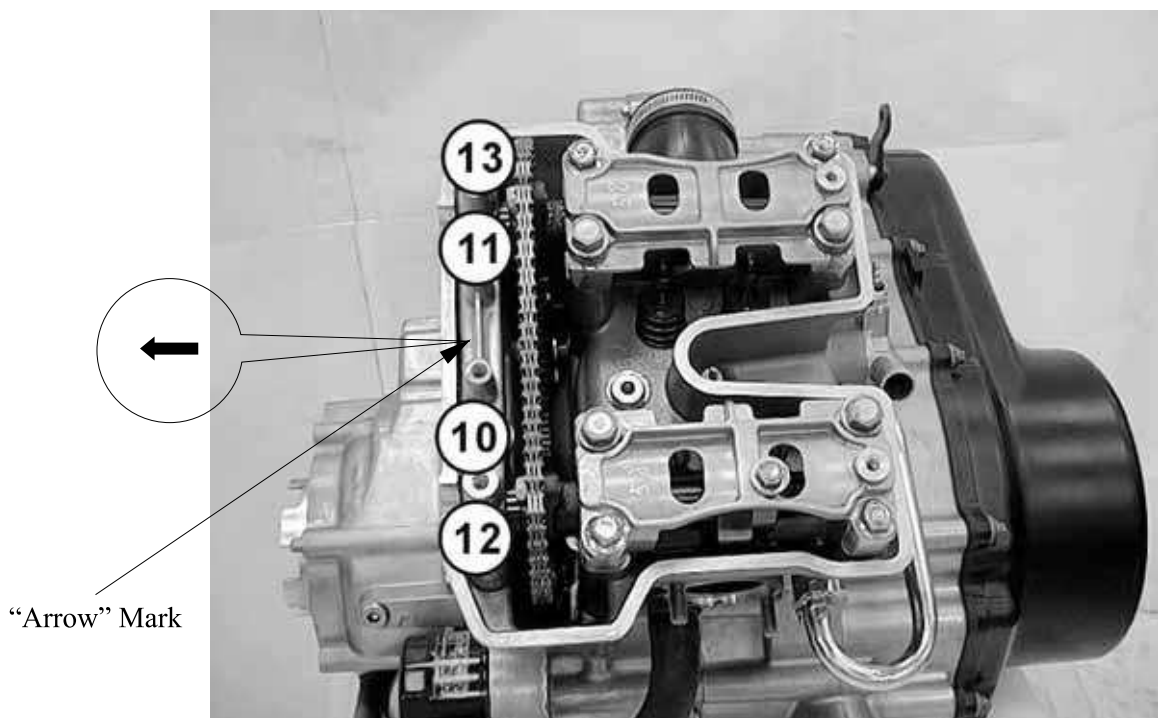

8. CYLINDER HEAD/VALVES

Install and tighten the two nuts under the cylinder head to the specified torque.

Torque: 1 kgf-m (10 N-m)

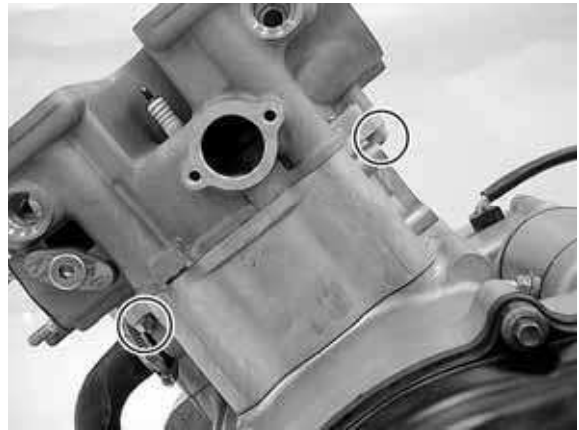

Install the water stop collar, gasket and water joint.
Install and tighten the two bolts to the specified torque.

Torque: 1.2 kgf-m (12 N-m)

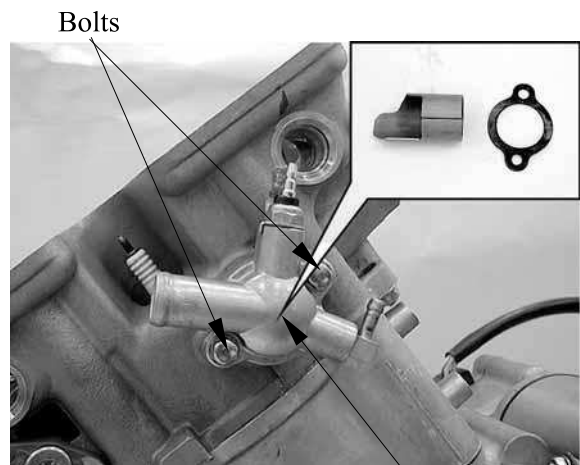

Water Joint/Gasket/Water Stop Collar

Install gasket and pair reed valve.
Install and tighten the five bolts and two nut securely.

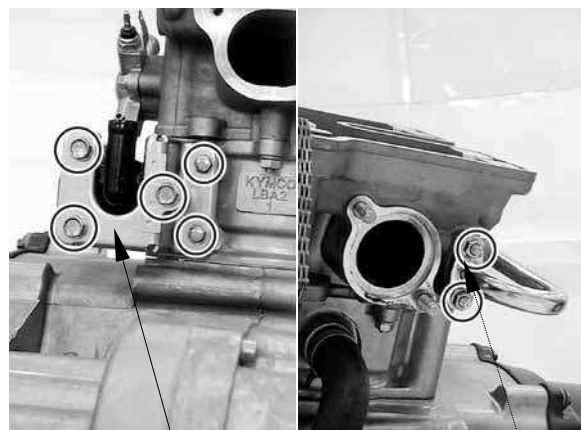

Pair Reed Valve Cover/Holder

Gasket

8. CYLINDER HEAD/VALVES

Install the new O-ring onto the intake pipe.



Install the intake pipe and tighten the two bolts securely.

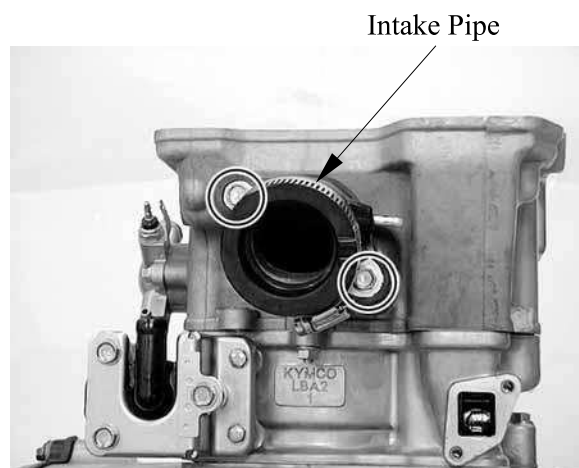

8. CYLINDER HEAD/VALVES

CYLINDER HEAD DISASSEMBLY/INSPECTION/ ASSEMBLY

Remove the cylinder head (refer to the “**CYLINDER HEAD REMOVAL/INSTALLATION**” section in this chapter).

Remove the valve spring cotters, retainers, springs, spring seats, oil seals and valves using a valve spring compressor.

*

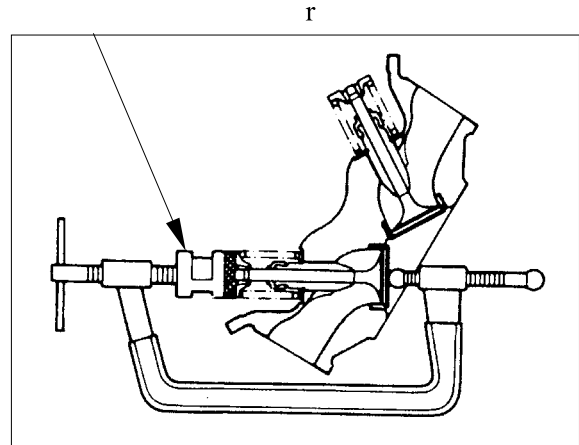

Special tool:

Valve Spring Compressor A120E00040

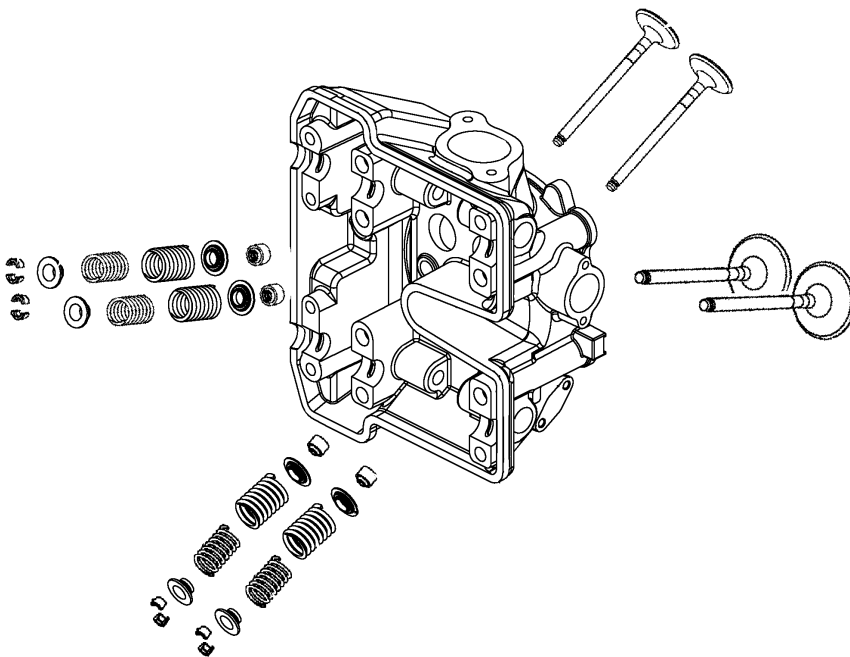

8. CYLINDER HEAD/VALVES

INSPECTION

Valve /Valve guide

Inspect each valve for bending, burning, scratches or abnormal stem wear.
If any defects are found, replace the valve with a new one.

Check valve movement in the guide.

Measure each valve stem O.D.

Measure each valve guide I.D.

Subtract each valve stem O.D. from the corresponding guide I.D. to obtain the stem-to-guide clearance.

Service limits:

IN: 0.08 mm

EX: 0.1 mm

* If the stem-to-guide clearance exceeds the service limits, replace the cylinder head is necessary.

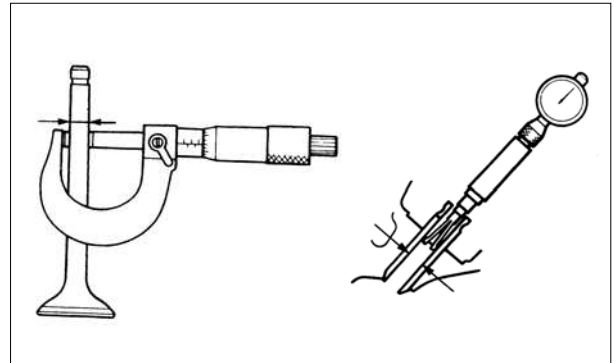

Cylinder head

Check the spark plug hole and valve areas for cracks.

Check the cylinder head for warpage with a straight edge and feeler gauge.

Service Limit: 0.05 mm (0.002 in)

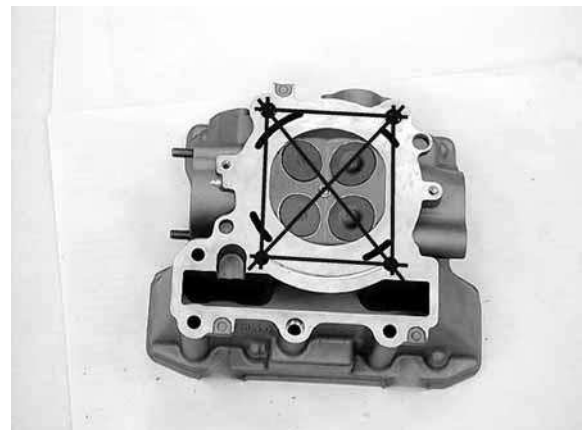

Valve spring

Measure the free length of the inner and outer valve springs.

Service Limit:

Inner: 33.4 mm

Outer: 38 mm

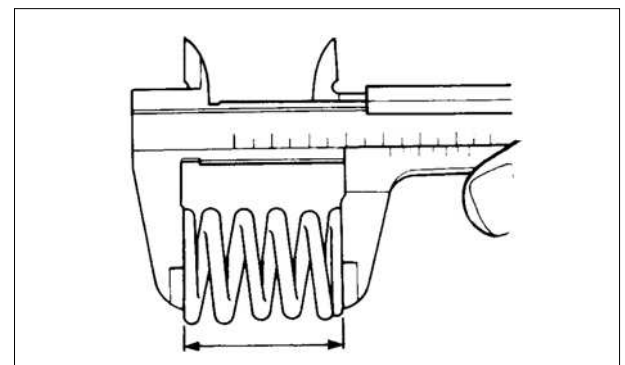

8. CYLINDER HEAD/VALVES

Measure compressed force (valve spring) and installed length.

Replace if out of specification.

Standard:

Inner: 3.5 kg (at 28.7 mm)

Outer: 13 kg (at 31.43 mm)

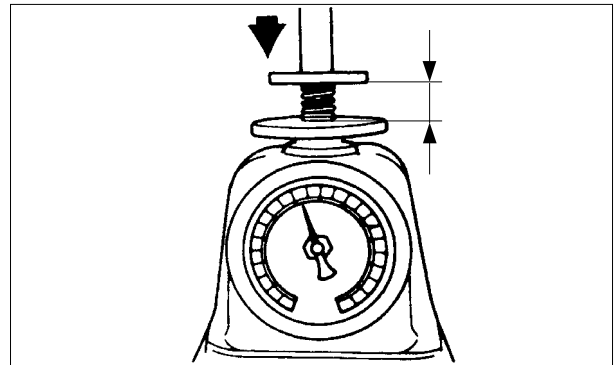

Measure the spring tilt.

Replace if out of specification.

Standard:

Inner: 1.2 mm

Outer: 1.2 mm

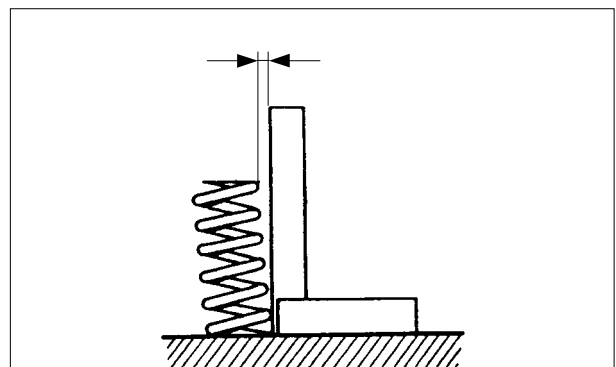

ASSEMBLY

Install the valve spring seats and oil seal.

* Be sure to install new oil seal.

Lubricate each valve with engine oil and insert the valves into the valve guides.
Install the valve springs and retainers.
Compress the valve springs using the valve spring compressor, then install the valve cotters.

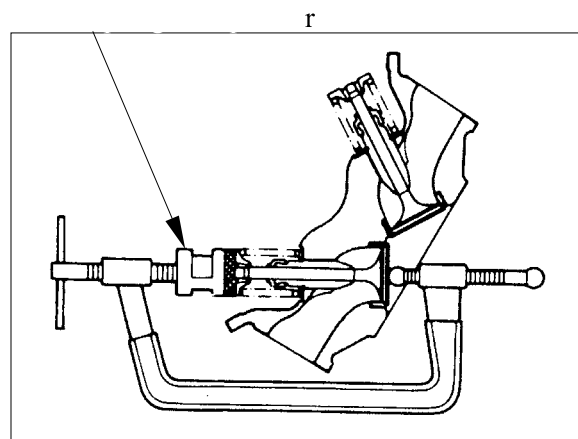

- * • When assembling, a valve spring compressor must be used.
• Install the cotters with the pointed ends facing down from the upper side of the cylinder head.

Special tool:

Valve Spring Compressor A120E00040

8. CYLINDER HEAD/VALVES

Tap the valve stems gently with a plastic hammer for 2~3 times to firmly seat the cotters.

* Be careful not to damage the valves.

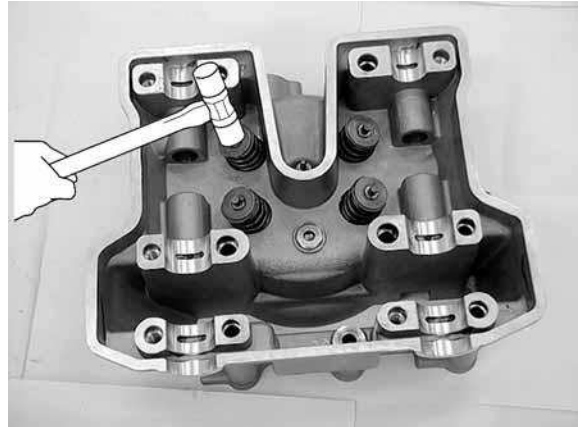

8. CYLINDER HEAD/VALVES

CAM CHAIN REMOVAL/INSPECTION/ INSTALLATION

REMOVAL

Remove the cylinder (refer to the “CYLINDER AND PISTON REMOVAL/INSPECTION/INSTALLATION” section in the chapter 9). Remove the oil pump drive chain (refer to “OIL PUMP REMOVAL/INSTALLATION” section in the chapter 4).

Remove the cam chain from the right crankcase.

Remove the two bolts and cam chain guides.

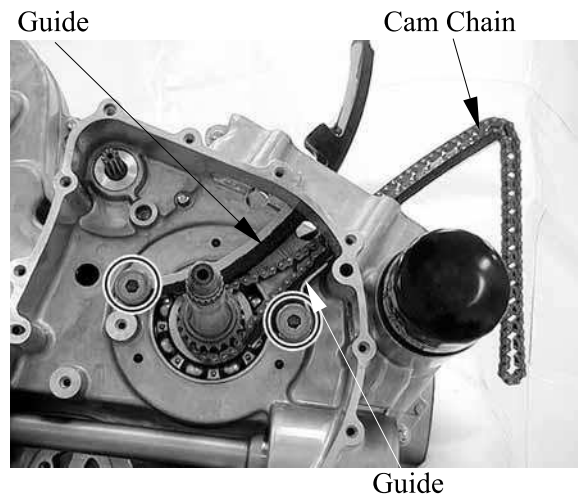

INSPECTION

Cam chain guide

Inspect the cam chain slipper surface of the cam chain guide for wear or damage.



Cam chain

Inspect the cam chain for cracks or stiff.

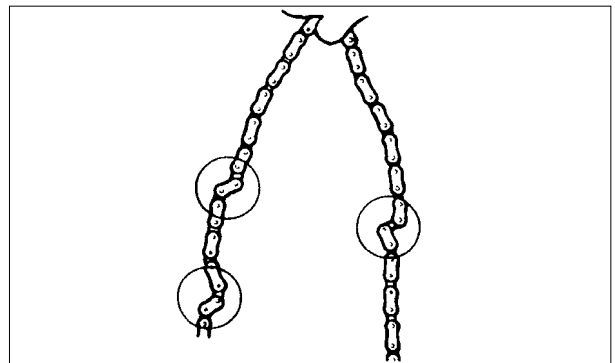

8. CYLINDER HEAD/VALVES

INSTALLATION

Installation is in the reverse order of removal.

Install the cam chain guides to the right crankcase and tighten the bolts to the specified torque.

Torque: 2 kgf-m (20 N-m)

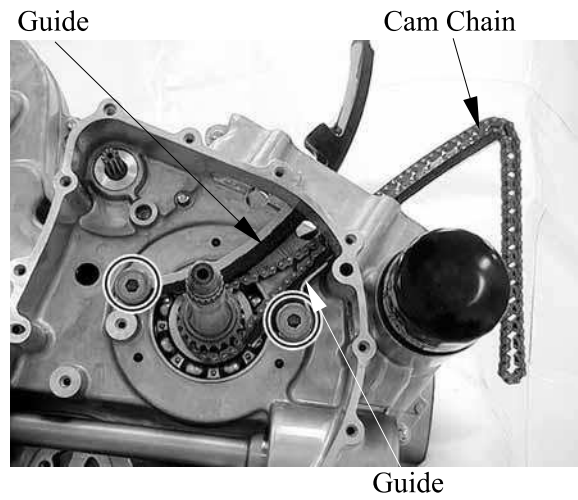

9. CYLINDER/PISTON

CYLINDER/PISTON

| | |
|---|-----|
| SCHEMATIC DRAWING ----- | 9-1 |
| SERVICE INFORMATION----- | 9-2 |
| TROUBLESHOOTING----- | 9-2 |
| CYLINDER AND PISTON REMOVAL/INSPECTION/ INSTALLATION ----- | 9-3 |

9. CYLINDER/PISTON

SCHEMATIC DRAWING

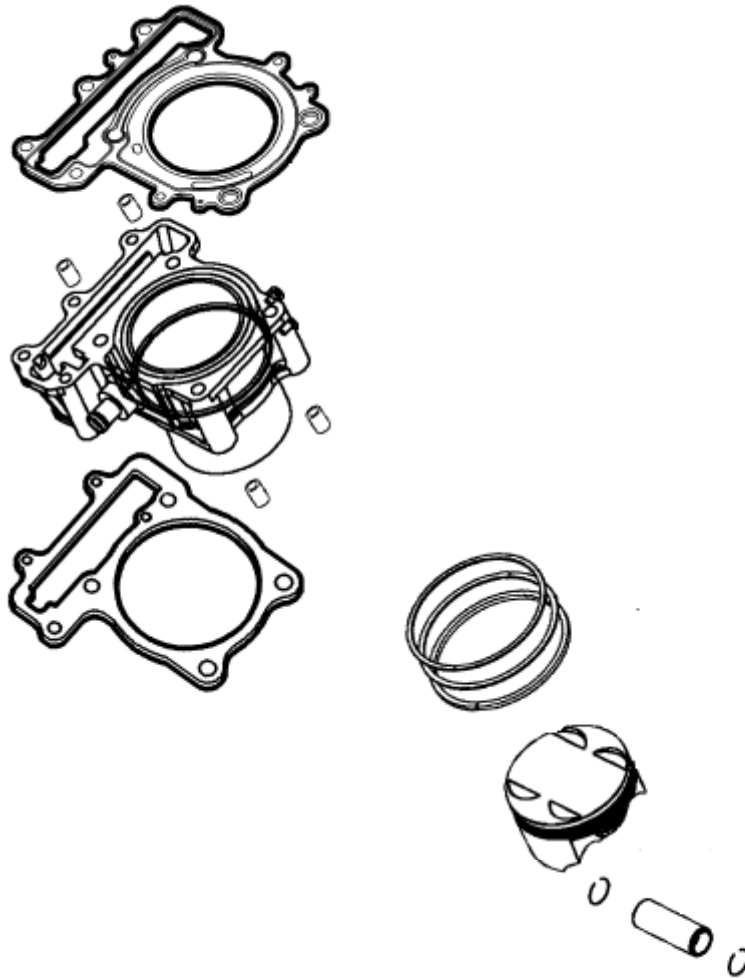

9. CYLINDER/PISTON

SERVICE INFORMATION

GENERAL INSTRUCTIONS

- The cylinder and piston can be serviced with the engine installed in the frame.
- When installing the cylinder, use a new cylinder gasket and make sure that the dowel pins are correctly installed.
- After disassembly, clean the removed parts and dry them with compressed air before inspection.

SPECIFICATIONS

Unit: mm (in)

| Item | | Standard | Service Limit | |
|------------------------------------|---------------------------------|---------------------------------|------------------------------|----------------|
| Cylinder | I.D. | 92.005 (3.6802)~92.015 (3.6806) | 92.1 (3.684) | |
| | Warpage | 0.01 (0.0004) | 0.05 (0.002) | |
| | Cylindricity | 0.01 (0.0004) | 0.1 (0.004) | |
| | True roundness | 0.01 (0.0004) | 0.1 (0.004) | |
| Piston, piston ring | Ring-to-groove clearance | top | 0.03 (0.0012)~0.065 (0.0026) | 0.08 (0.003) |
| | | Second | 0.015 (0.0006)~0.05 (0.002) | 0.065 (0.0026) |
| | Ring end gap | top | 0.15 (0.006)~0.3 (0.012) | 0.5 (0.02) |
| | | Second | 0.03 (0.012)~0.45 (0.018) | 0.65 (0.026) |
| | | Oil side rail | 0.2 (0.008)~0.7 (0.028) | 1 (0.04) |
| | Piston O.D. | 91.96 (3.6784)~91.98 (3.6793) | 91.9 (3.676) | |
| | Piston O.D. measuring position | 10 mm from bottom of skirt | — | |
| | Piston-to-cylinder clearance | 0.01 (0.0004)~0.045 (0.0018) | 0.1 (0.004) | |
| Piston pin hole I.D. | 22.002 (0.8801)~22.008 (0.8803) | 22.04 (0.8816) | | |
| Piston pin O.D | | 21.994 (0.8798)~22 (0.88) | 21.96 (0.8784) | |
| Piston-to-piston pin clearance | | 0.002 (0.0001)~0.014 (0.0006) | 0.02 (0.001) | |
| Connecting rod small end I.D. bore | | 22.016 (0.8806)~22.034 (0.8814) | 22.06 (0.8824) | |

TORQUE VALUES

Cylinder bolt 1 kgf-m (10 N-m, 7.2 lbf-ft)

TROUBLESHOOTING

- When hard starting or poor performance at low speed occurs, check the crankcase breather for white smoke. If white smoke is found, it means that the piston rings are worn, stuck or broken.

Compression too low or uneven compression

- Worn or damaged cylinder and piston rings
- Worn, stuck or broken piston rings

Compression too high

- Excessive carbon build-up in combustion chamber or on piston head

Excessive smoke from exhaust muffler

- Worn or damaged piston rings
- Worn or damaged cylinder and piston

Abnormal noisy piston

- Worn cylinder, piston and piston rings
- Worn piston pin hole and piston pin
- Incorrectly installed piston

9. CYLINDER/PISTON

CYLINDER AND PISTON REMOVAL/INSPECTION/ INSTALLATION

REMOVAL

Remove the cylinder head (refer to “**CYLINDER HEAD REMOVAL/INSTALLATION**” section in the chapter 8).

Take the block pin out.
Remove the water hose from the cylinder.
Remove the two cylinder bolts/washers.
Remove the cylinder.

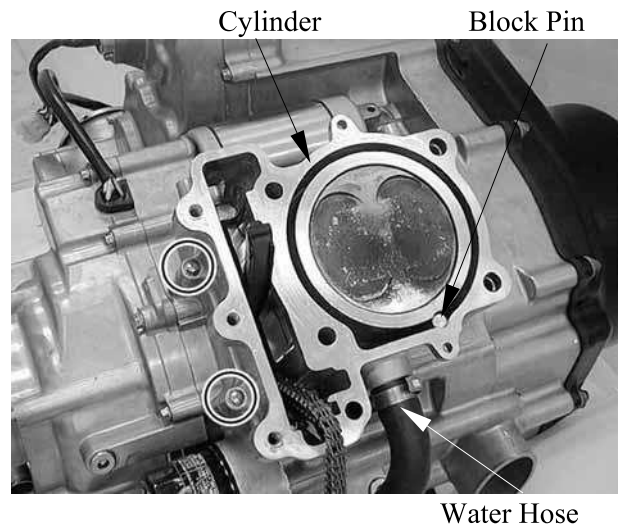

Remove the dowel pins and gasket.

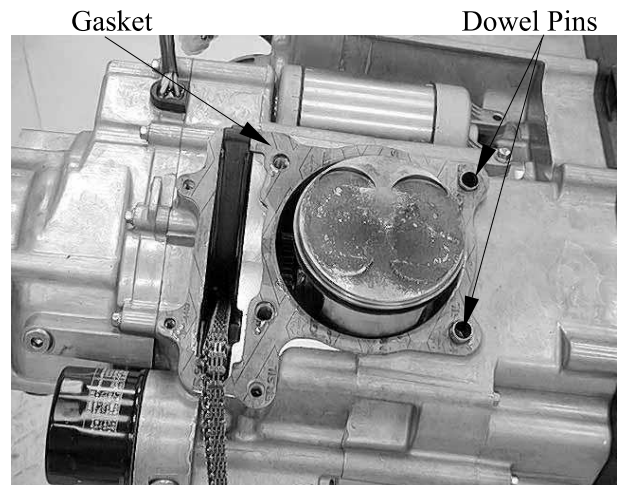

Remove the piston pin clip.

* Place a clean shop towel in the crankcase to keep the piston pin clip from falling into the crankcase.

Press the piston pin out of the piston and remove the piston.

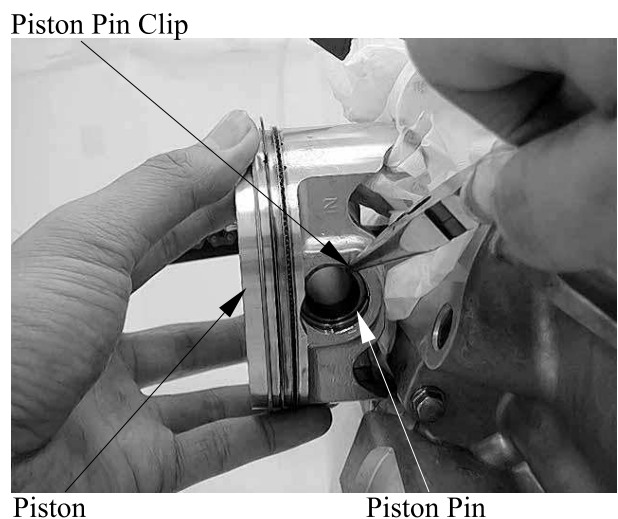

9. CYLINDER/PISTON

Spread each piston ring and remove it by lifting up at a point opposite the gap

- * Do not damage the piston ring by spreading the ends too far.

Clean carbon deposits from the piston ring grooves.

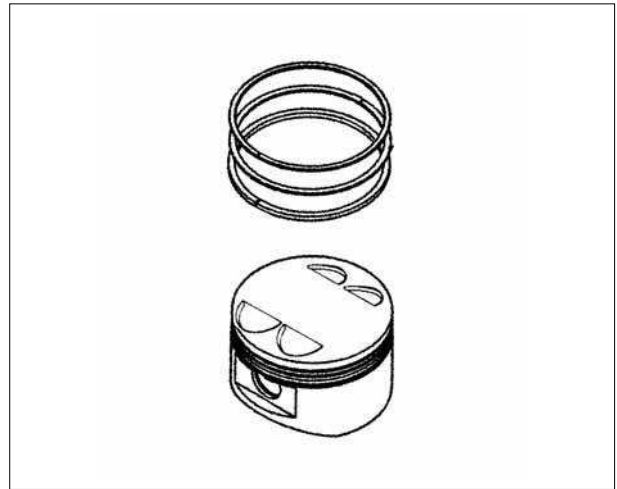

INSPECTION

Piston ring

Inspect the piston rings for movement by rotating the rings. The rings should be able to move in their grooves without catching.

Push the ring until the outer surface of the piston ring is nearly flush with the piston and measure the ring-to-groove clearance.

Service Limits:

Top: 0.08 mm (0.003 in)
2nd: 0.065 mm (0.0026 in)

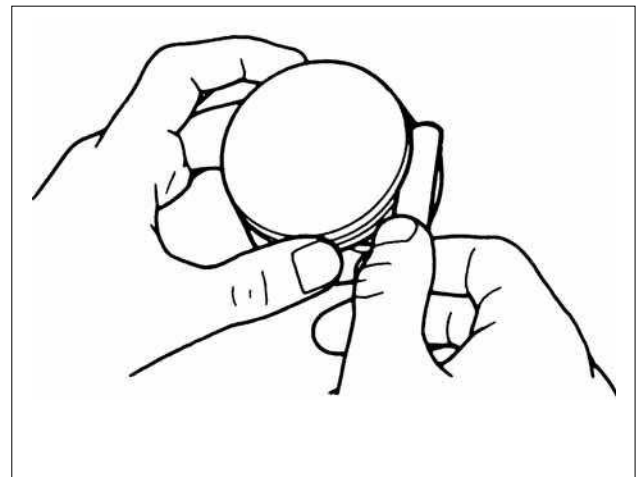

Insert each piston ring into the bottom of the cylinder squarely.

- * Use the piston head to push each piston ring into the cylinder.

Measure the piston ring end gap.

Service Limit:

Top: 0.5 mm (0.02 in)
2nd: 0.65 mm (0.026 in)
Oil ring: 1 mm (0.04 in)

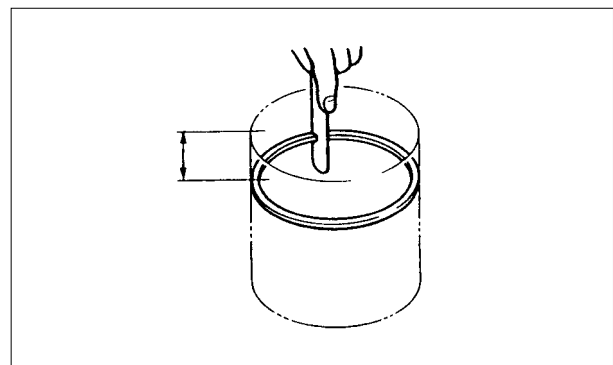

9. CYLINDER/PISTON

Piston/Piston pin

Measure the piston O.D. at the point (A) from the bottom and 90° to the piston pin hole.

Service Limit:

91.9 mm (3.676 in) at (A): 10 mm

Calculate the cylinder-to-piston clearance.

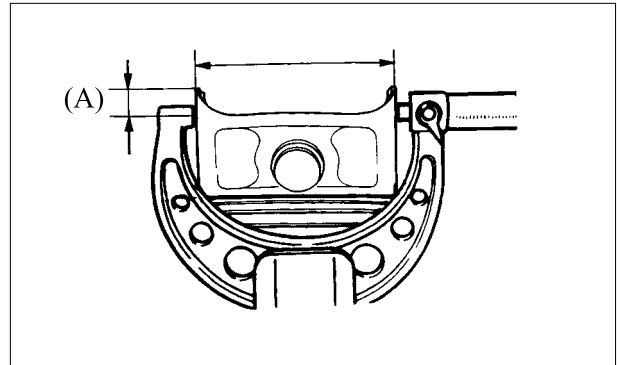

Measure the piston pin hole. Take the maximum reading to determine the I.D..

Service Limit: 22.04 mm (0.8816 in)

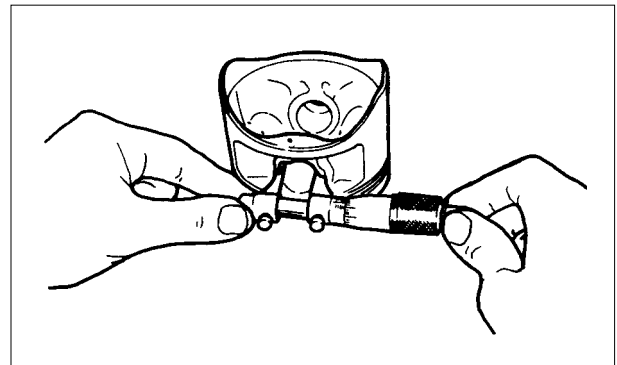

Measure the piston pin O.D. at piston and connecting rod sliding areas.

Service Limit: 21.96 mm (0.8784 in)

Measure the piston-to-piston pin clearance.

Service Limit: 0.02 mm (0.001 in)

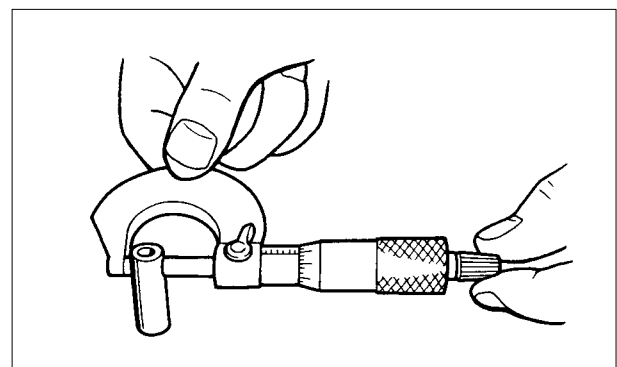

9. CYLINDER/PISTON

Cylinder

Check the cylinder for warpage with a straight edge and feeler gauge in the directions shown.

Service Limit: 0.05 mm (0.002 in)

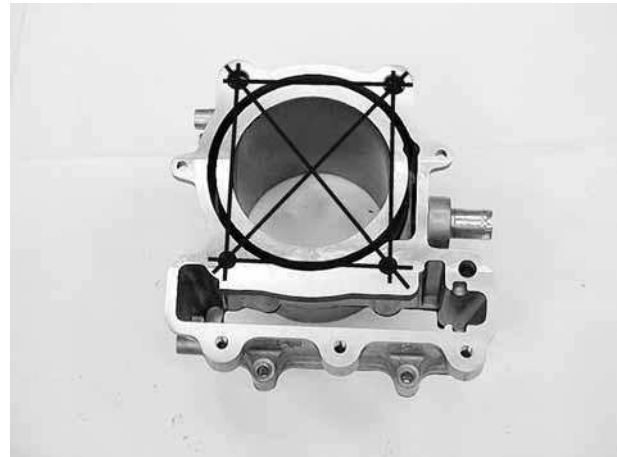

Check the cylinder wall for wear or damage. Measure and record the cylinder I.D. at three levels in an X and Y axis. Take the maximum reading to determine the cylinder wear.

Service Limit: 92.1 mm (3.684 in)

Calculate the piston-to-cylinder clearance. Take a maximum reading to determine the clearance.

Service Limit: 0.1 mm (0.004 in)

Calculate the taper and out-of-round at three levels in an X and Y axis. Take the maximum reading to determine them.

Service Limit:

Taper: 0.1 mm (0.004 in)

Out-of-round: 0.1 mm (0.004 in)

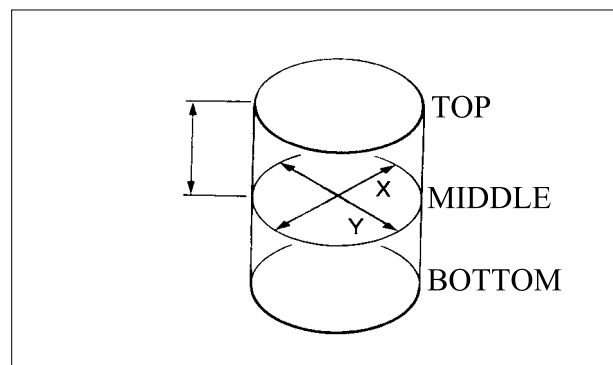

9. CYLINDER/PISTON

Measure the connecting rod small end I.D..

Service Limit: 22.06 mm (0.8824 in)

Calculate the connecting rod-to-piston pin clearance.

Service Limit: 0.06 mm (0.002 in)

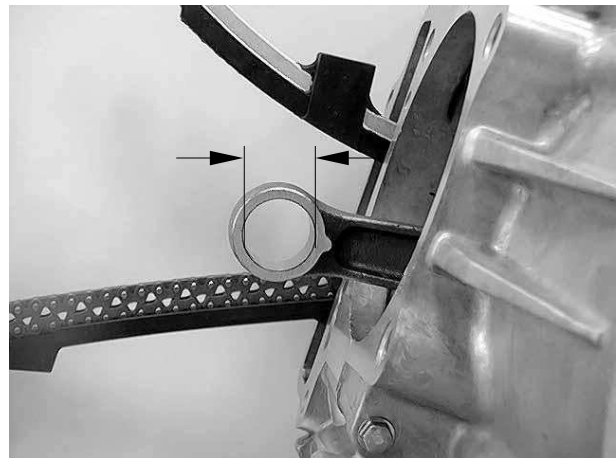

INSTALLATION

Piston ring

Carefully install the piston rings into the piston ring grooves with the markings facing up.

* Be careful not to damage the piston and rings.

- ◆ Do not confuse the top and second rings.
- ◆ To install the oil ring, install the oil ring, then install the side rails.

Stagger the piston ring end gaps 120° degrees apart from each other.

Stagger the side rail end gaps as shown.

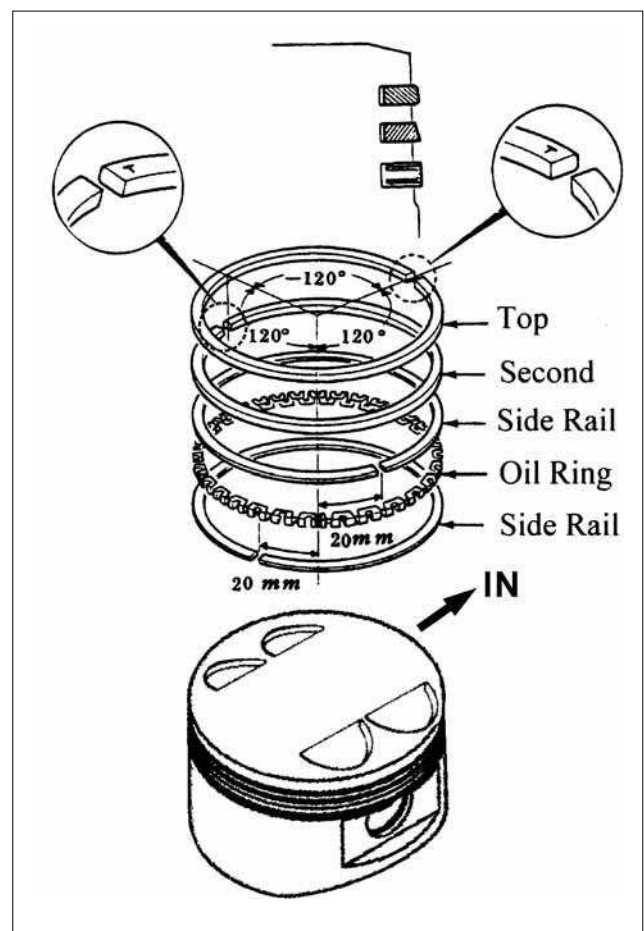

9. CYLINDER/PISTON

Cylinder/Piston

Clean any gasket material from the cylinder mating surfaces of the crankcase and oil passage.

Apply engine oil to the piston pin.

Apply engine oil to the connecting rod small end and piston pin hole.

Install the piston with the “IN” mark face intake side and piston pin.

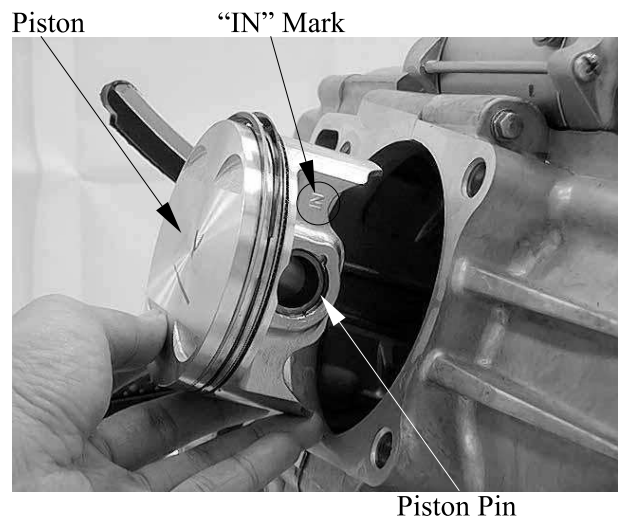

Place a clean shop towel over the crankcase prevent the clip from falling into the crankcase.

Install the new pin clip.

- * ♦Make sure that the piston pin clips are seated securely.
♦Do not align the piston pin clip end gap with the piston cut-out

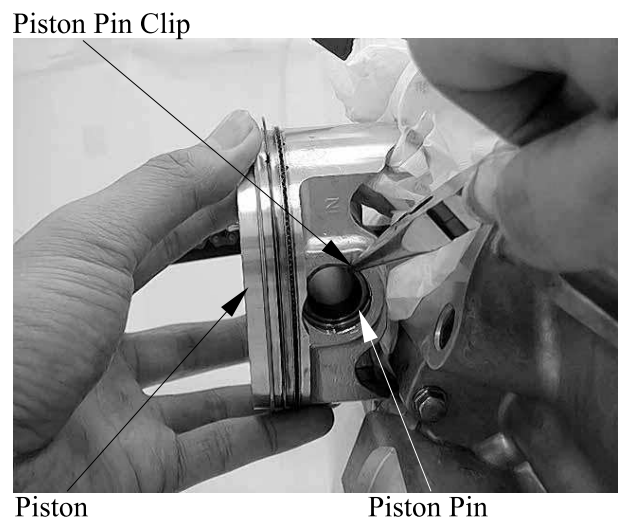

Install the dowel pins and gasket.

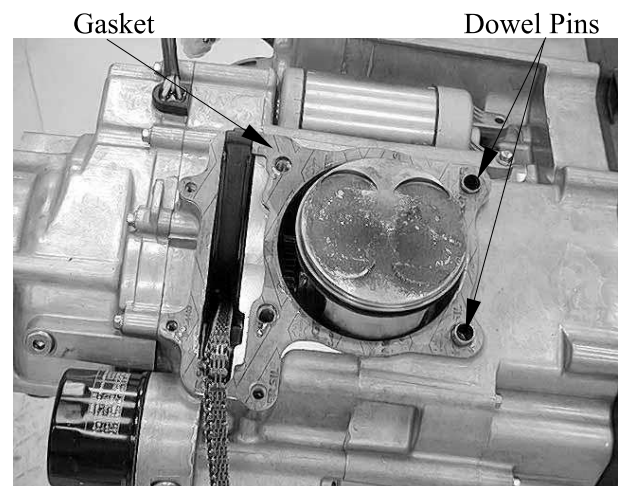

9. CYLINDER/PISTON

Apply engine oil to the cylinder wall, piston and piston ring outer surfaces.

Pass the cam chain through the cylinder and install the cylinder over the piston.

* Be careful not to damage the piston rings and cylinder walls.

Install the two cylinder bolts/washers and after the cylinder head and holders has installed (refer to the “**CYLINDER HEAD REMOVAL/INSTALLATION**” section in the chapter 8), then tighten the two cylinder bolts to specified torque.

Torque: 10 N•m (1 kgf•m, 7 lbf•ft)

Install the block pin.

Connect the water hose.

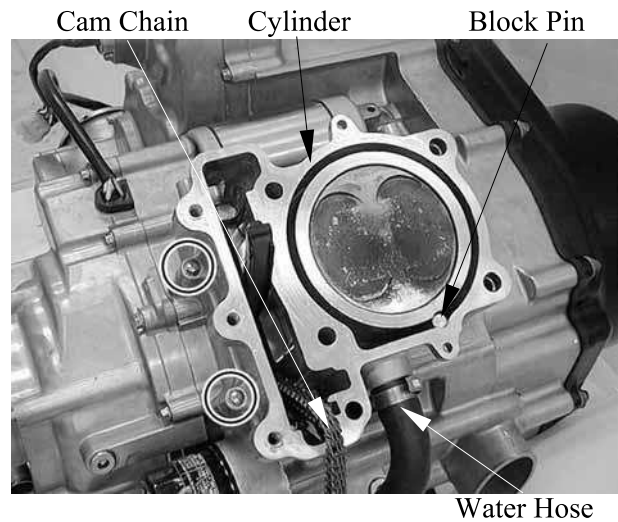

10. DRIVE PULLEY/DRIVEN PULLEY/CLUTCH

10. DRIVE PULLEY/DRIVEN PULLEY/CLUTCH

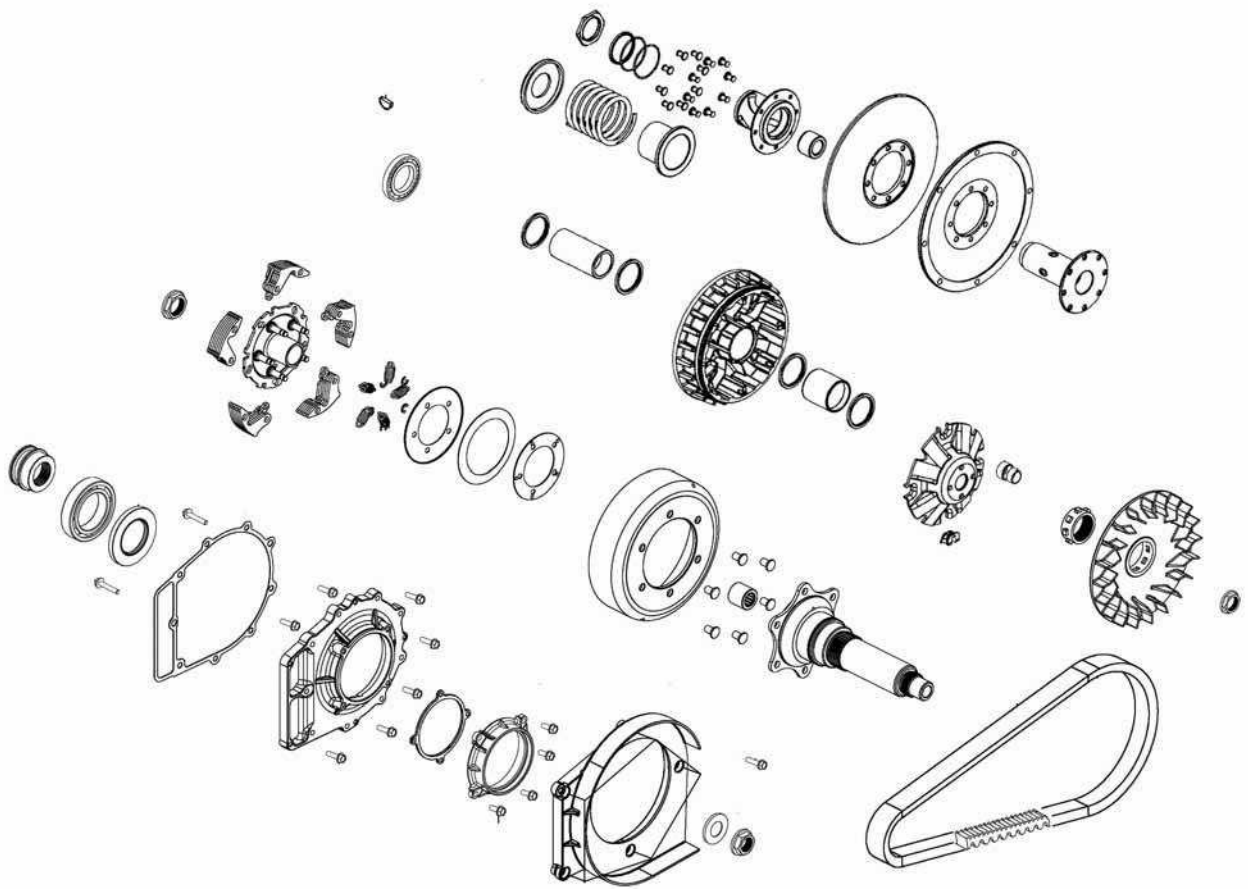

10. DRIVE PULLEY/DRIVEN PULLEY/CLUTCH

| m | Standard | Service Limit |
|-----------------------|---------------------------|---------------|
| Drive belt width | 34.1 (1.364) | 30.8 (1.232) |
| Clutch shoe thickness | 1.5 (0.06) | 1 (0.04) |
| Driven pulley spring | 124.3 (4.972) | 121.3 (4.852) |
| Weight roller O.D. | 29.9 (1.196)~30.1 (1.204) | 29.5 (1.18) |

TORQUE VALUES

| | | |
|----------------------------------|----------------------------------|--------------------------|
| Drive pulley nut | 14 kgf-m (140 N-m, 100.8 lbf-ft) | Apply oil to the threads |
| Clutch nut | 14 kgf-m (140 N-m, 100.8 lbf-ft) | |
| Driven pulley nut | 10 kgf-m (100 N-m, 72 lbf-ft) | Apply oil to the threads |
| Driven pulley assembly plate nut | 7.5 kgf-m (75 N-m, 54 lbf-ft) | |

SPECIAL TOOLS

| | |
|---------------------------------|------------|
| Oil seal & bearing install | A120E00014 |
| Bearing puller | A120E00037 |
| Y-type holder | A120E00056 |
| Drive pulley holder | A120E00058 |
| Driven pulley spring compressor | A120E00059 |
| Lock nut wrench | A120E00079 |

TROUBLESHOOTING

Engine starts but ATV won't move

- Worn drive belt
- Broken ramp plate
- Worn or damaged clutch lining
- Broken driven face spring

Engine stalls or ATV creeps

- Broken clutch weight spring

Lack of power

- Worn drive belt
- Weak driven face spring
- Worn weight roller
- Faulty driven face

10. DRIVE PULLEY/DRIVEN PULLEY/CLUTCH

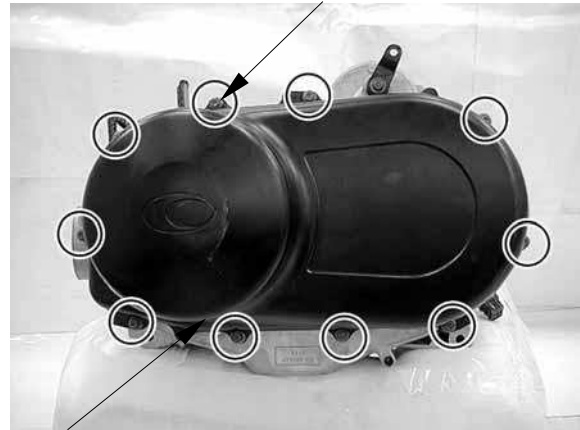

Dowel Pins

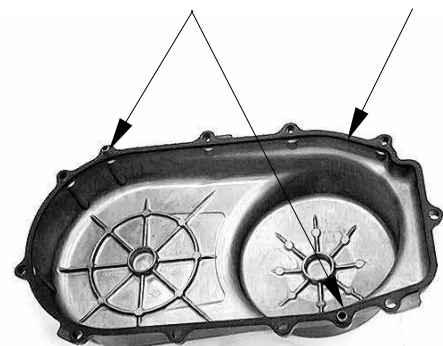
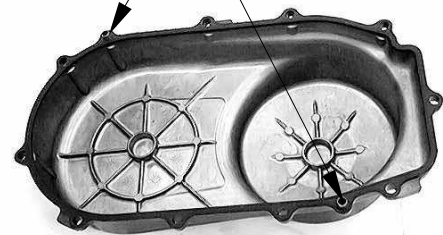

t

10. DRIVE PULLEY/DRIVEN PULLEY/CLUTCH



10. DRIVE PULLEY/DRIVEN PULLEY/CLUTCH

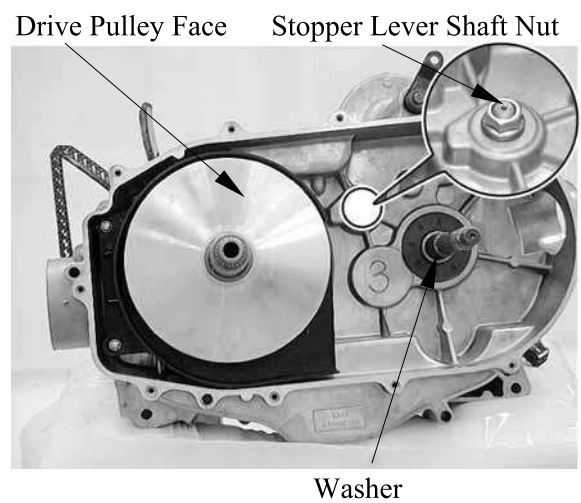
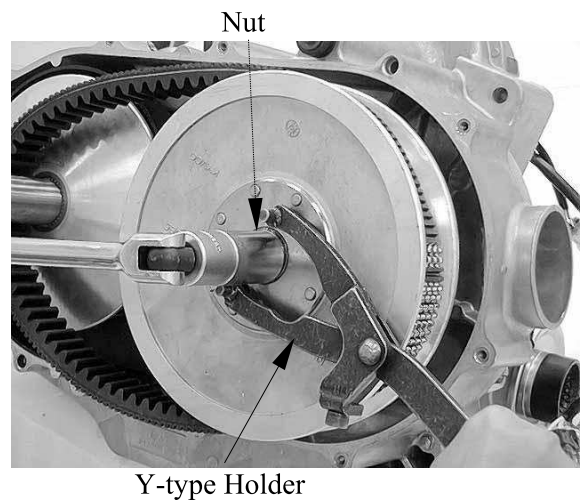
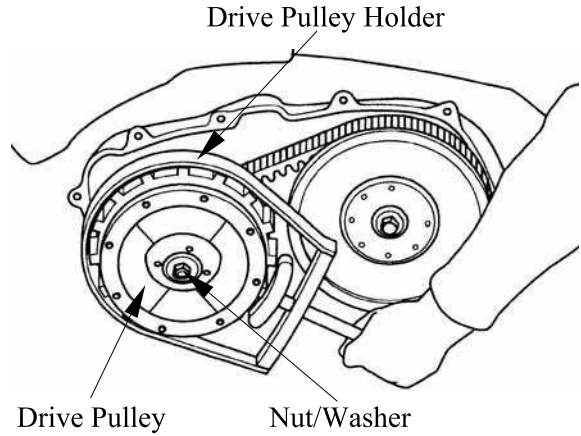

* Do not loosen the stopper lever shaft nut, it may cause stopper lever bolt loosen. To tighten the stopper lever bolt must remove the crankcase (refer to the **“TRANSMISSION REMOVAL/INSPECTION/INSTALLATION”** section in the chapter 11).

10. DRIVE PULLEY/DRIVEN PULLEY/CLUTCH

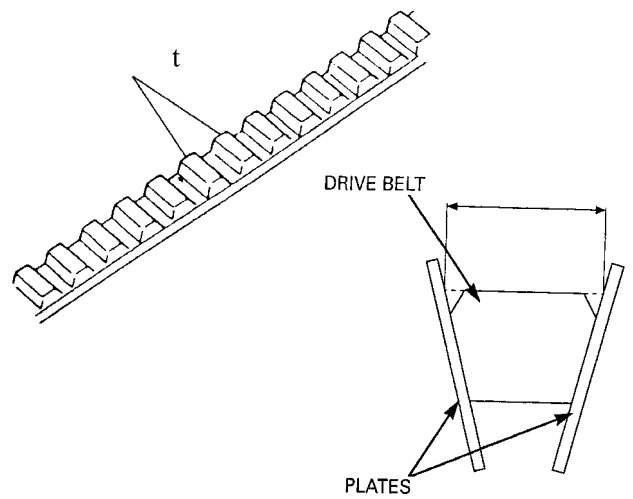
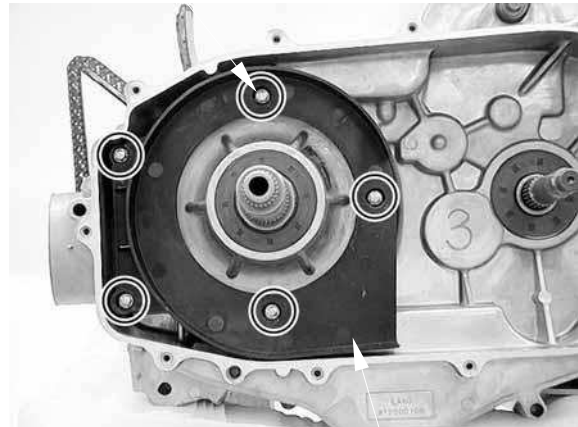

Drive Pulley Face

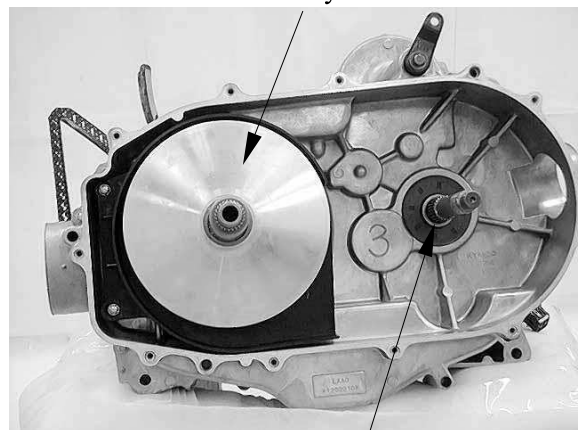

r

10. DRIVE PULLEY/DRIVEN PULLEY/CLUTCH

*

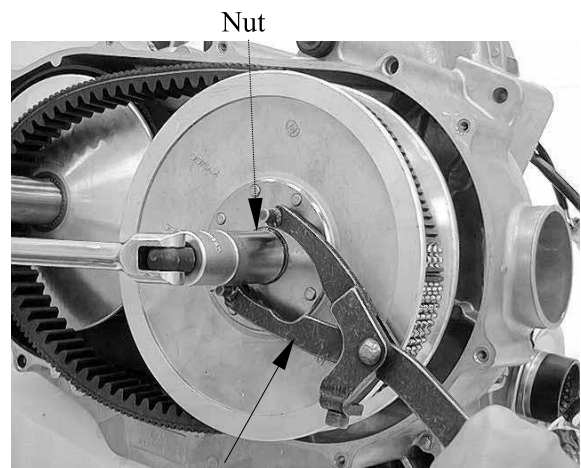

Y-type Holder



Drive Face Boss

10. DRIVE PULLEY/DRIVEN PULLEY/CLUTCH

*

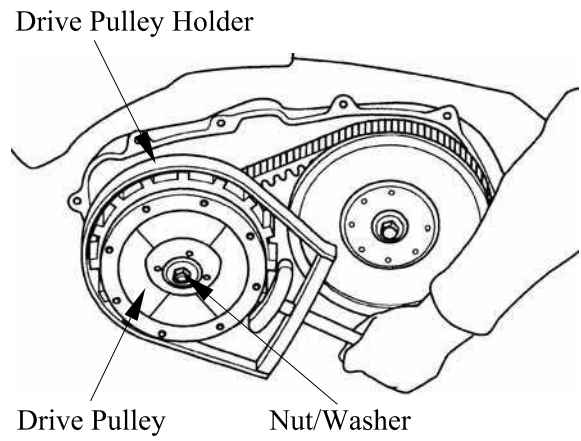

10. DRIVE PULLEY/DRIVEN PULLEY/CLUTCH

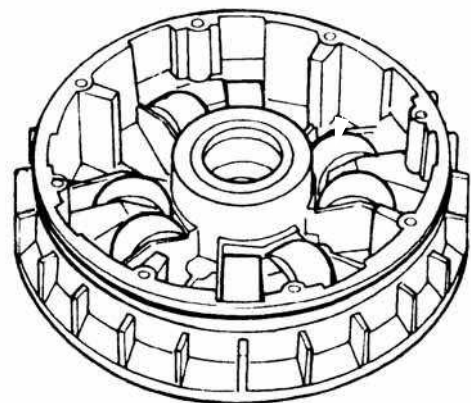
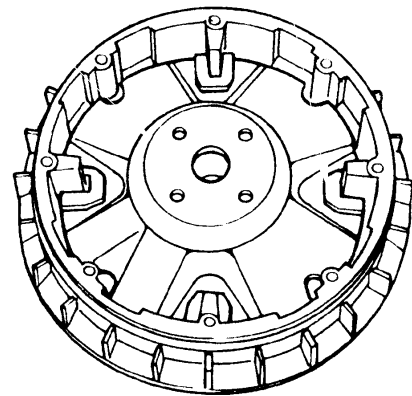

10. DRIVE PULLEY/DRIVEN PULLEY/CLUTCH

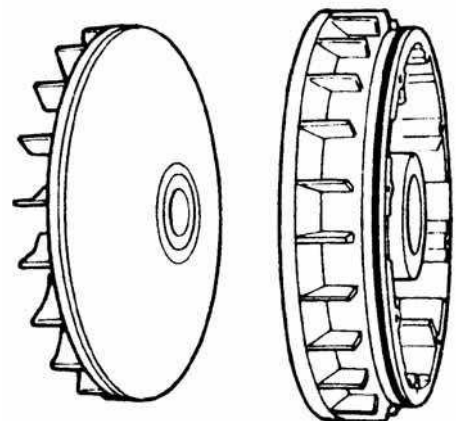
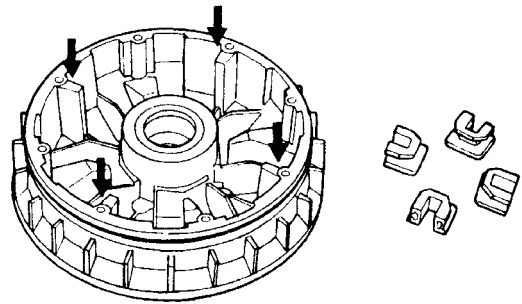
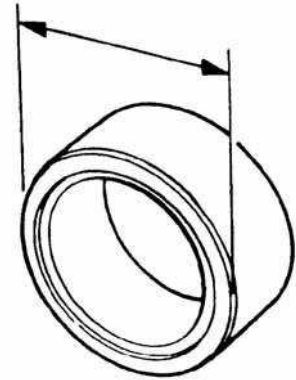

10. DRIVE PULLEY/DRIVEN PULLEY/CLUTCH



*

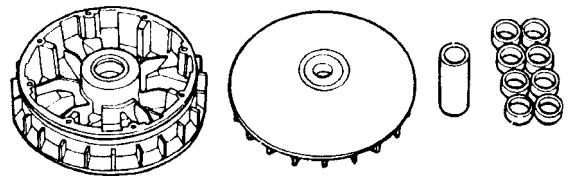

* The direction of all weight rollers is the same. The thin side is towards to counterclockwise.

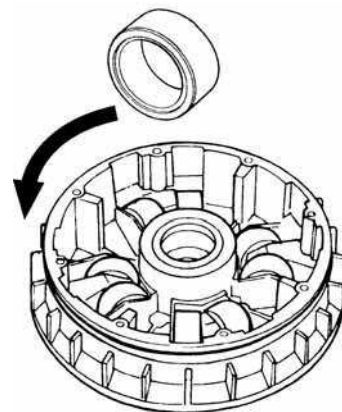

10. DRIVE PULLEY/DRIVEN PULLEY/CLUTCH

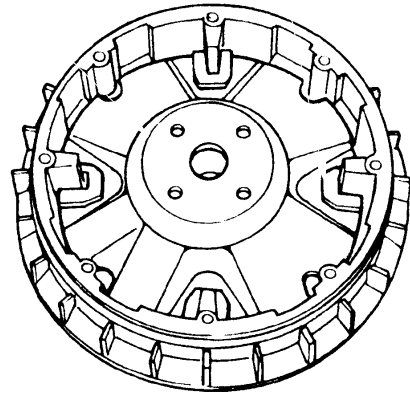

Drive Face Boss



10. DRIVE PULLEY/DRIVEN PULLEY/CLUTCH

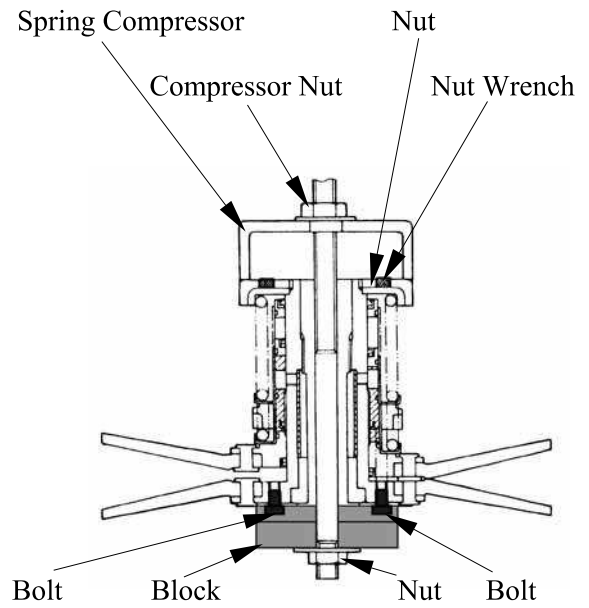

*

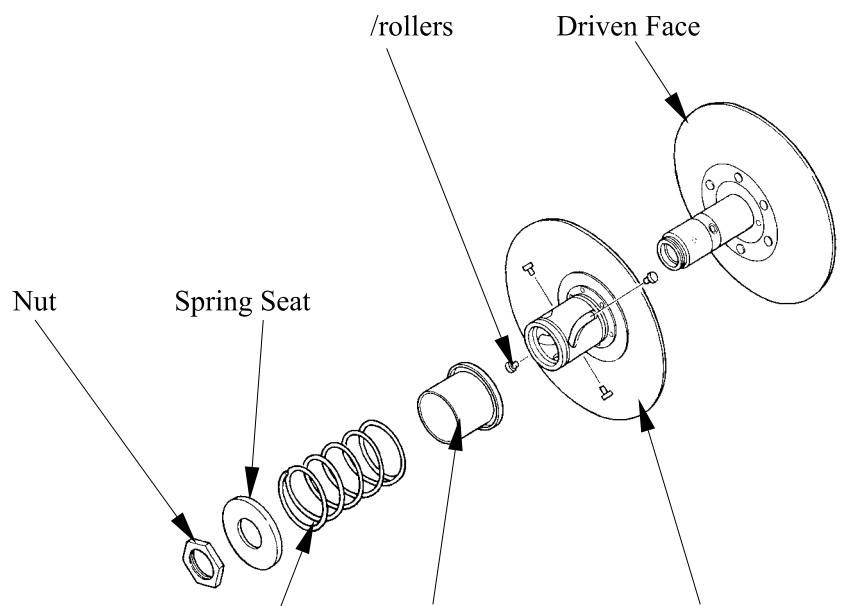
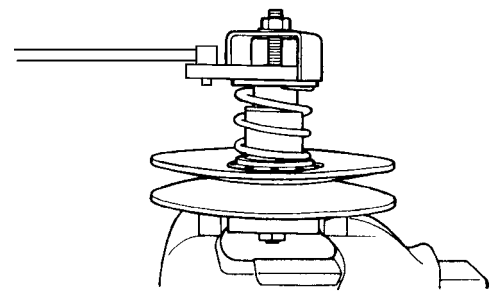

10. DRIVE PULLEY/DRIVEN PULLEY/CLUTCH

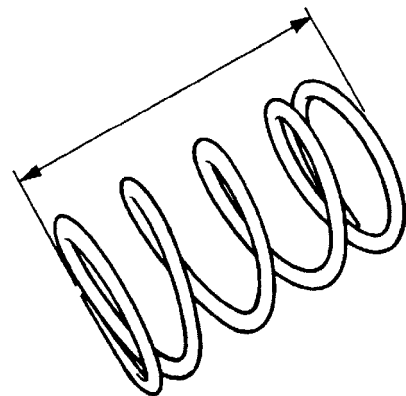
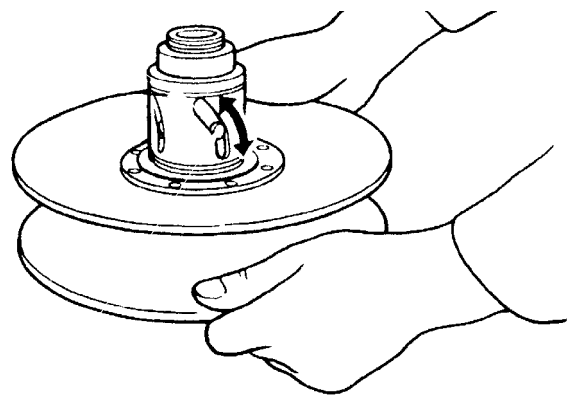

10. DRIVE PULLEY/DRIVEN PULLEY/CLUTCH

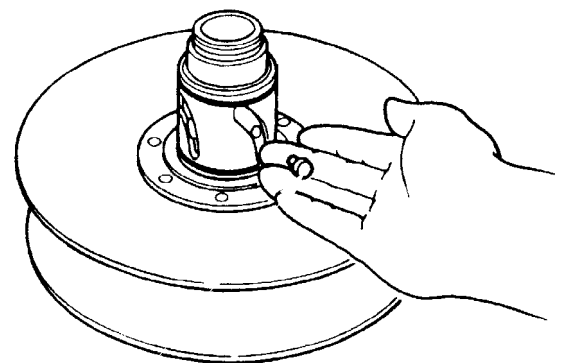
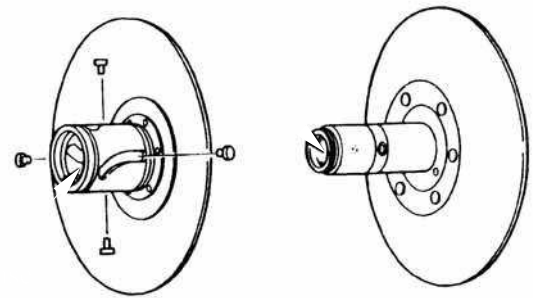

10. DRIVE PULLEY/DRIVEN PULLEY/CLUTCH

- * d
- spring compressor to the driven pulley assembly.
- Place the block in a vise and secure it.
 - Tighten the spring compressor nut and compress the spring.
 - Install the nut and tighten it to the specified torque with the nut wrench.
 - Remove the spring compressor and nut wrench.

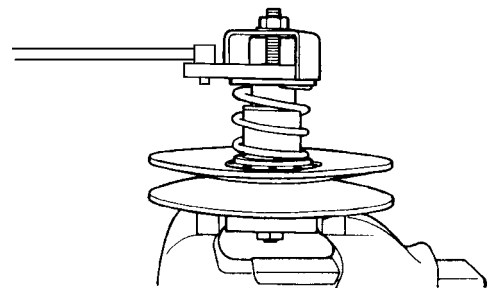
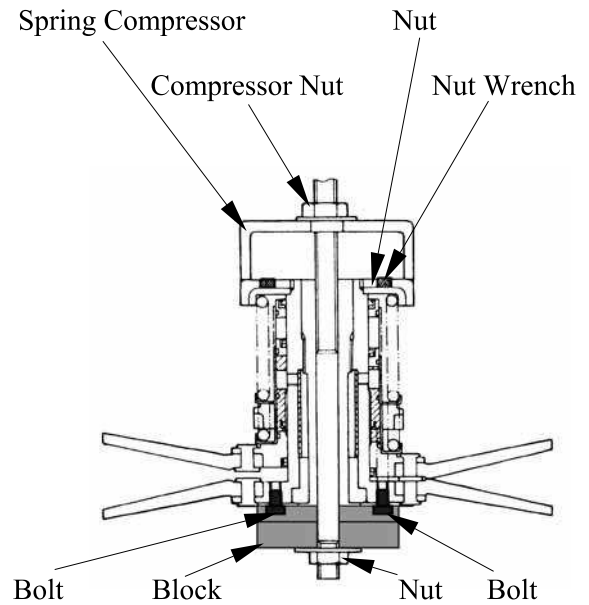

10. DRIVE PULLEY/DRIVEN PULLEY/CLUTCH

One-way Clutch Bearing

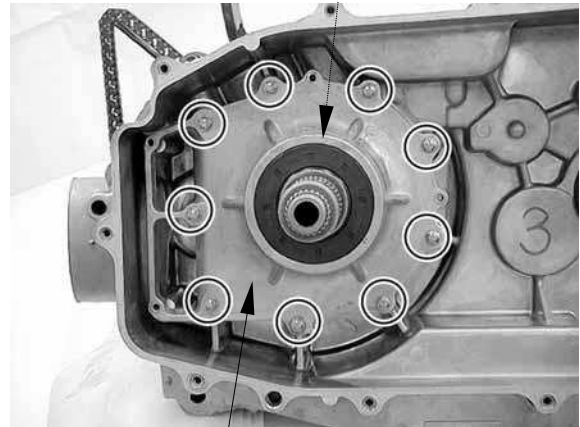

Clutch Housing Assembly

*

Dowel Pins

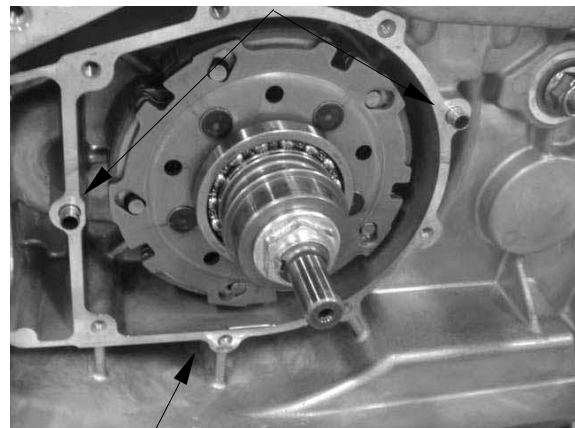

Gasket

Nut

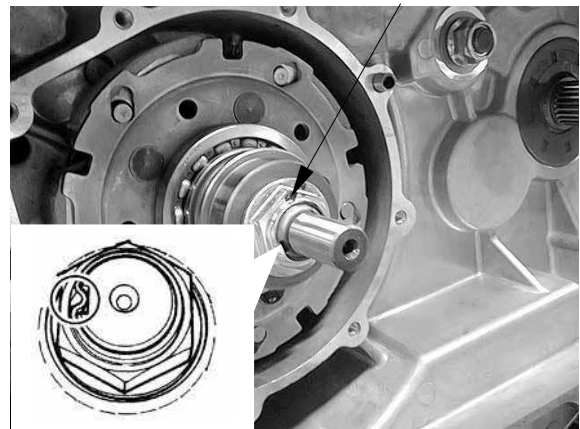

10. DRIVE PULLEY/DRIVEN PULLEY/CLUTCH

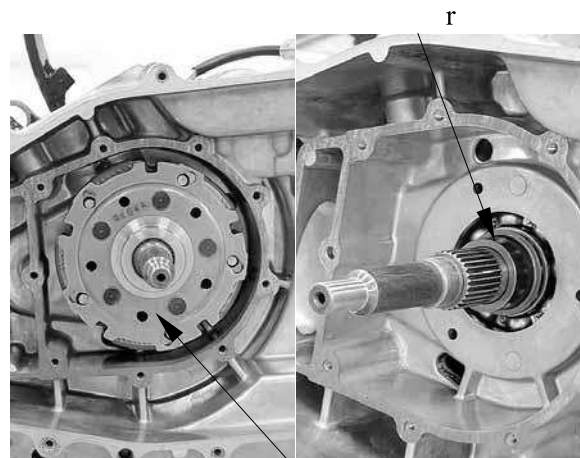
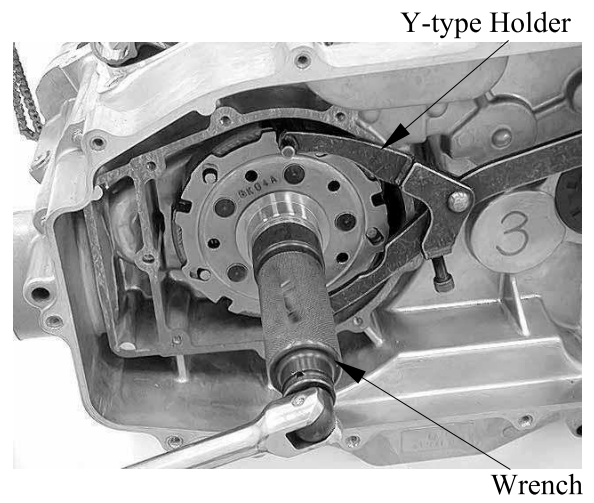

10. DRIVE PULLEY/DRIVEN PULLEY/CLUTCH

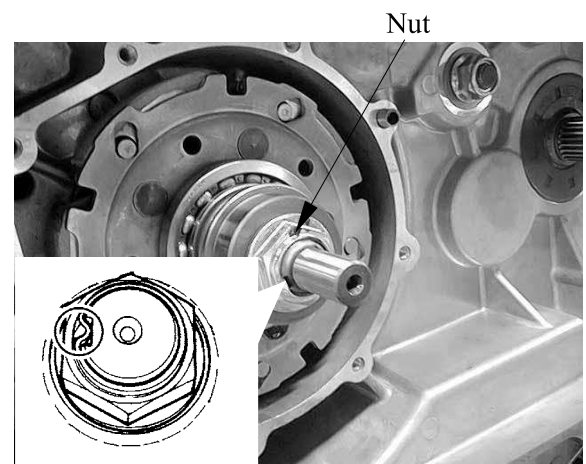
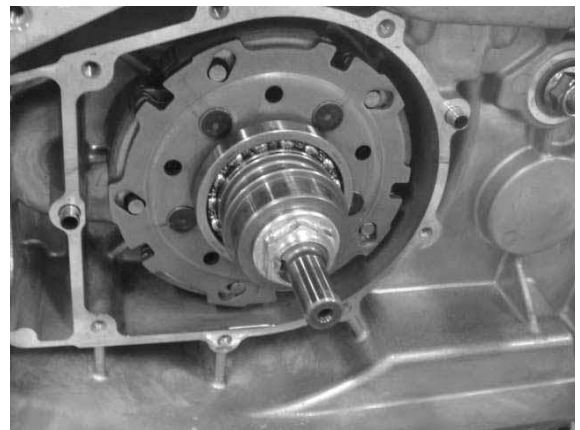
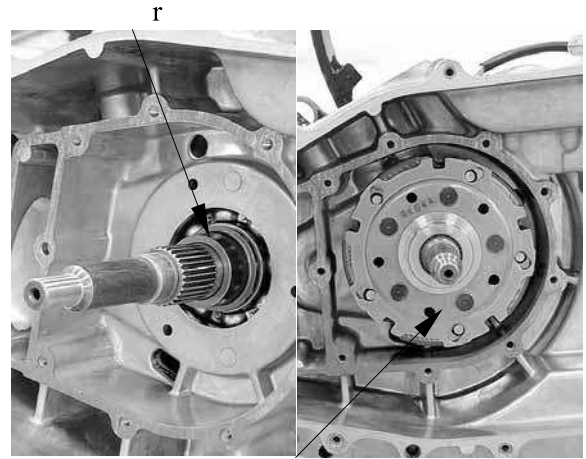

10. DRIVE PULLEY/DRIVEN PULLEY/CLUTCH

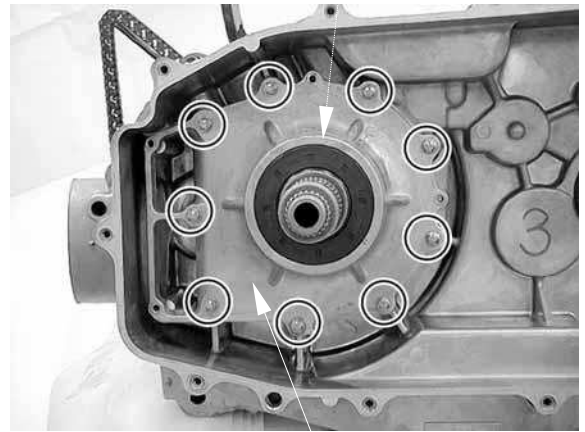
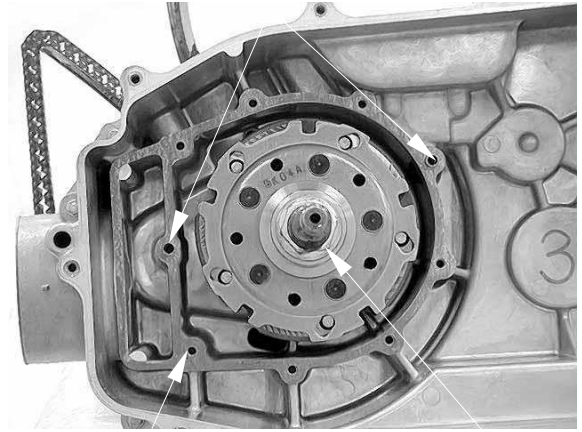

10. DRIVE PULLEY/DRIVEN PULLEY/CLUTCH

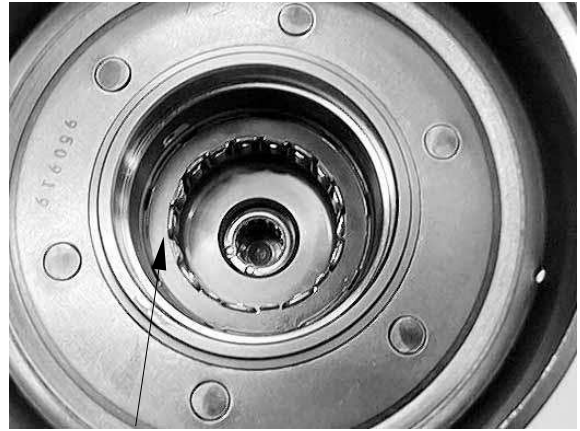

One-way Clutch Bearing

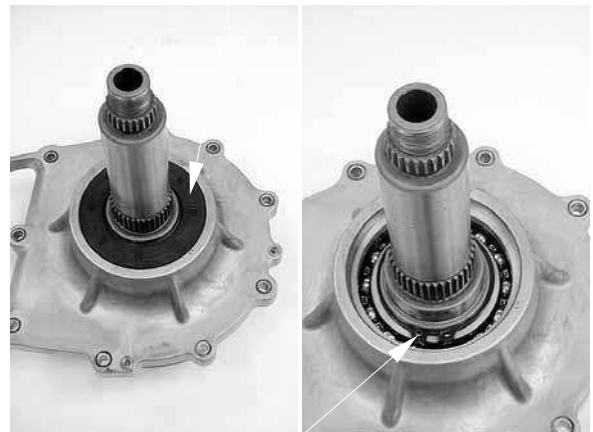

Snap Ring

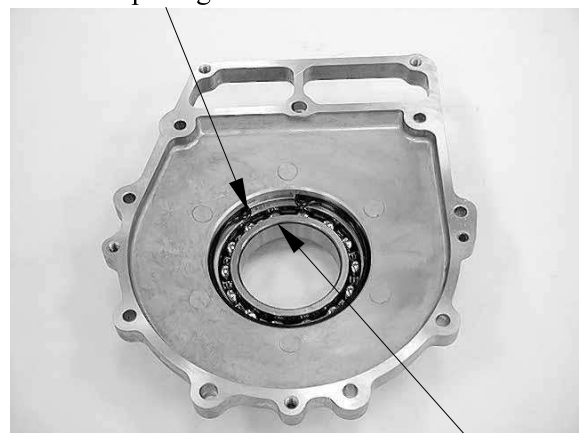

Bearing

10. DRIVE PULLEY/DRIVEN PULLEY/CLUTCH

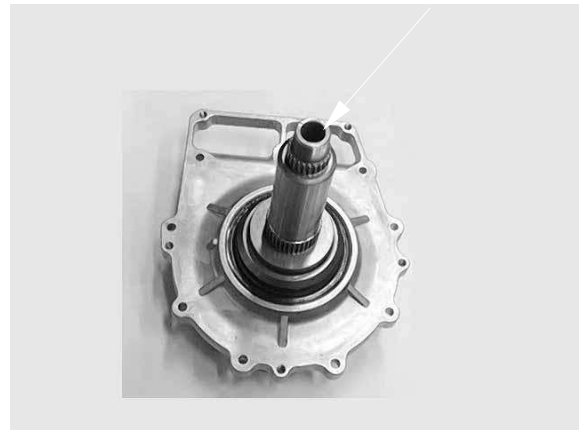

10. DRIVE PULLEY/DRIVEN PULLEY/CLUTCH

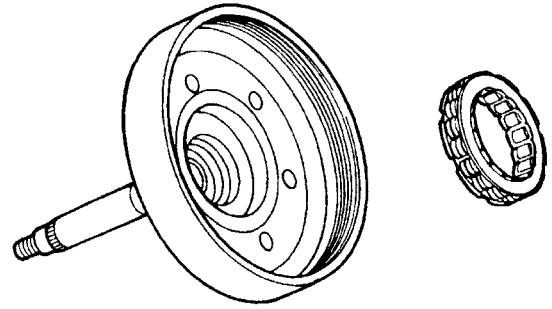

*

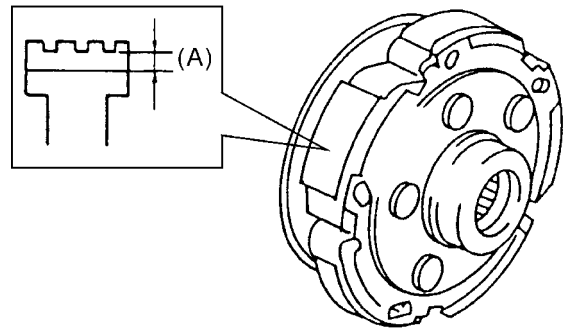

10. DRIVE PULLEY/DRIVEN PULLEY/CLUTCH

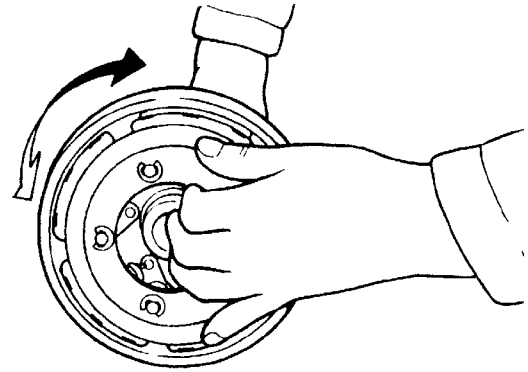

Needle Bearing

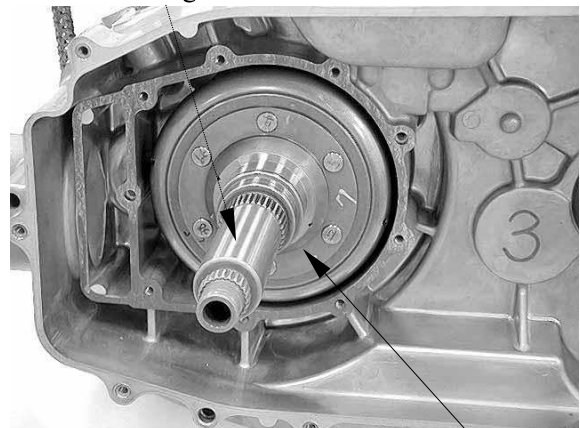

10. DRIVE PULLEY/DRIVEN PULLEY/CLUTCH

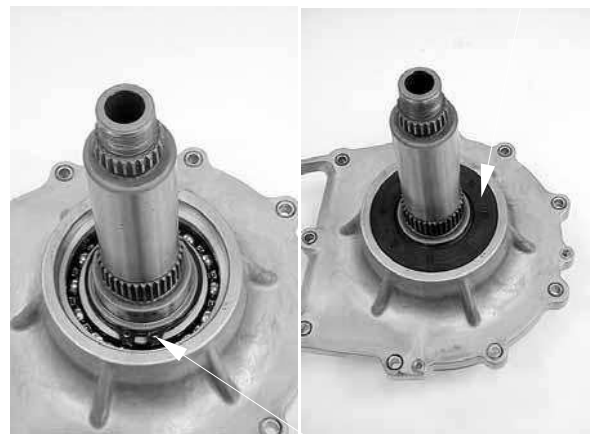

10. DRIVE PULLEY/DRIVEN PULLEY/CLUTCH

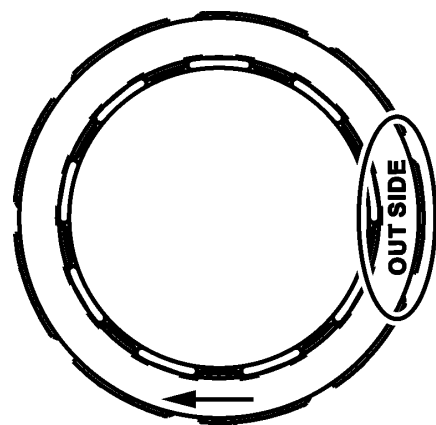
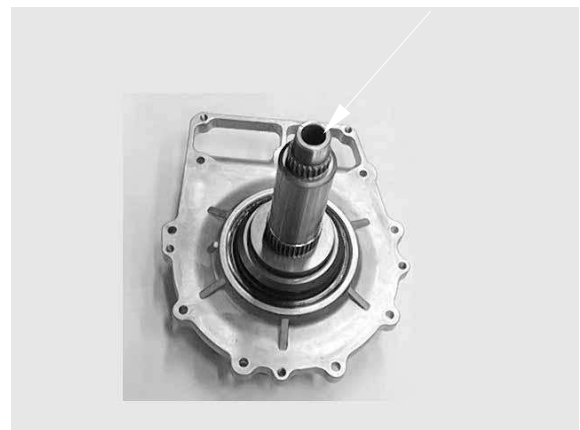
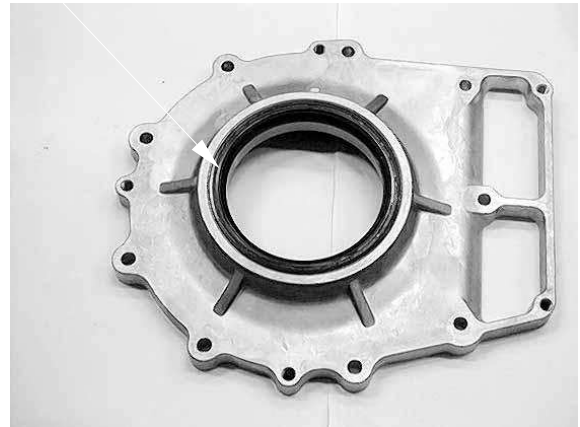

*

FINAL REDUCTION/TRANSMISSION SYSTEM

SERVICE INFORMATION----- 11- 2
TROUBLESHOOTING----- 11- 2
SECONDARY DRIVE/DRIVEN BEVEL GEAR
REMOVAL/INSPECTION/INSTALLATION ----- 11- 3
SECONDARY GEAR SHIMS ADJUSTMENT ----- 11- 8
RIGHT CRANKCASE REMOVAL/INSTALLATION----- 11-10
BEARING REPLACEMENT IN THE RIGHT CRANKCASE ----- 11-12
TRANSMISSION REMOVAL/INSPECTION/INSTALLATION --- 11-17
UPPER SHIFT FORK DISASSEMBLY/ASSEMBLY ----- 11-25
DRIVE SHAFT DISASSEMBLY/ASSEMBLY/INSPECTION ----- 11-26
COUNTERSHAFT DISASSEMBLY/ASSEMBLY/INSPECTION-- 11-27



11.FINAL REDUCTION/ TRANSMISSION SYSTEM



MXU 500 IRS

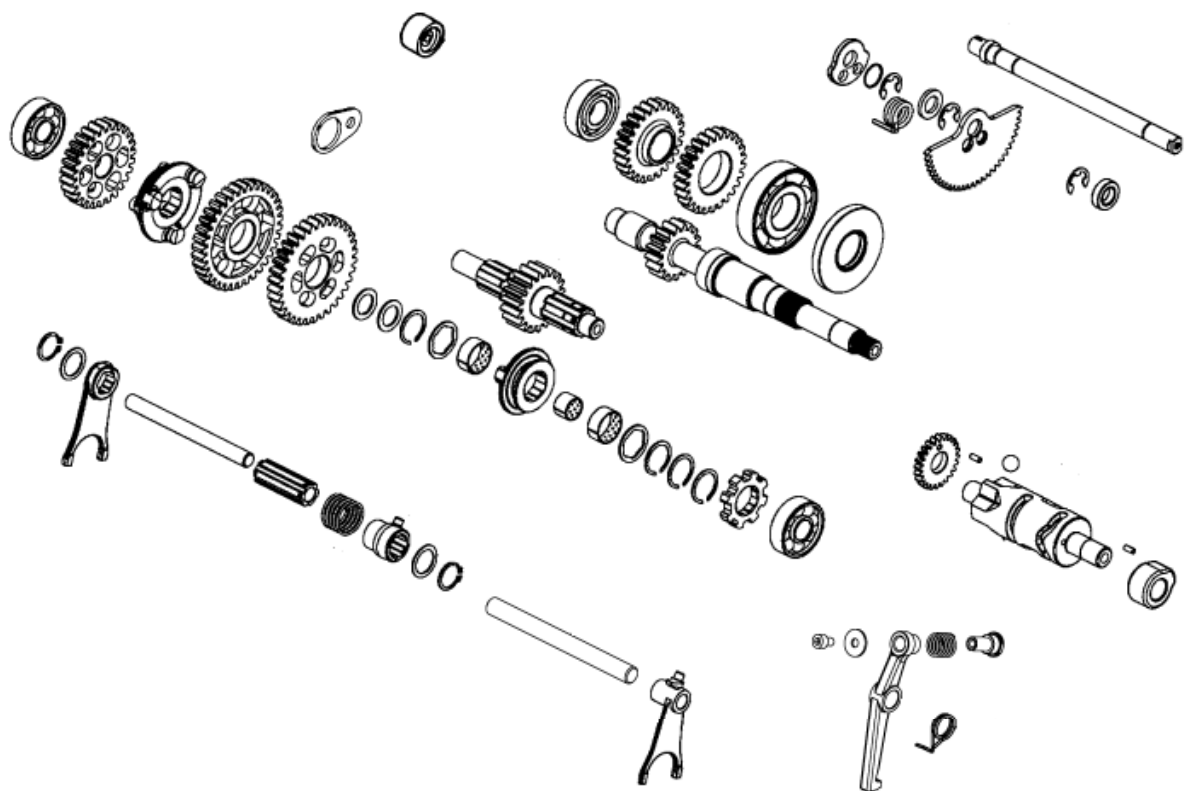

11.FINAL REDUCTION/ TRANSMISSION SYSTEM

SERVICE INFORMATION

GENERAL INSTRUCTIONS

- The bevel gear and output shaft can be serviced with the engine installed in the frame.

SPECIAL TOOL

| | |
|----------------|------------|
| Y-type holder | A120E00056 |
| Bearing puller | A120E00037 |
| Bearing drive | A120E00014 |
| Nut wrench | A120E00066 |

TORQUE VALUES

| | | |
|--------------------------|--------------------|------------------|
| Crankcase bolt | 1.2 kgf-m (12 N-m) | Apply engine oil |
| Drive bevel gear nut | 14 kgf-m (140 N-m) | Apply engine oil |
| Driven bevel gear nut | 14 kgf-m (140 N-m) | Apply engine oil |
| Stopper lever boss nut | 3 kgf-m (30 N-m) | |
| Stopper lever bolt | 2.5 kgf-m (25 N-m) | |
| Shift cam stopper plug | 4.8 kgf-m (48 N-m) | |
| Output shaft bearing nut | 11 kgf-m (110 N-m) | Apply engine oil |

TROUBLESHOOTING

Engine starts but motorcycle won't move

- Damaged transmission
- Seized or burnt transmission

Oil leaks

- Oil too rich
- Worn or damaged oil seal

11.FINAL REDUCTION/ TRANSMISSION SYSTEM



MXU 500 IRS

SECONDARY DRIVE/DRIVEN BEVEL GEAR REMOVAL/INSPECTION/INSTAL LATION

REMOVAL

Drain engine oil into a clean container. (Refer to the “ENGINE OIL” section in the chapter 3).

Move the engine assembly forward (refer to the “ENGINE REMOVAL” section in the chapter 6) or remove the rear propeller (refer to the “REAR PROPELLER SHAFT DISASSEMBLY/INSPECTION/ASSEMBLY” section in the chapter 13).

Remove the five bolts, then remove the bevel gear case cover.

Remove the two dowel pins and gasket.

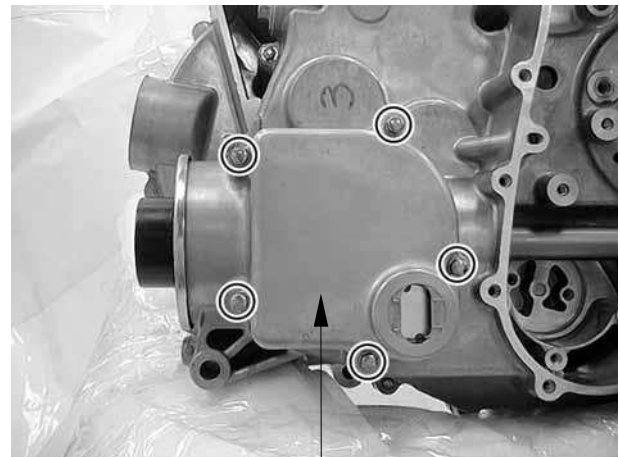

Bevel Gear Case Cover

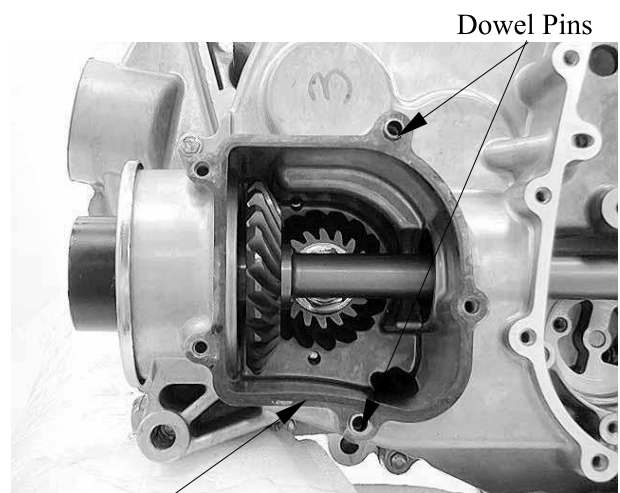

Gasket

Rear Middle Joint

Using a chisel, unlock the nut in the rear middle joint.

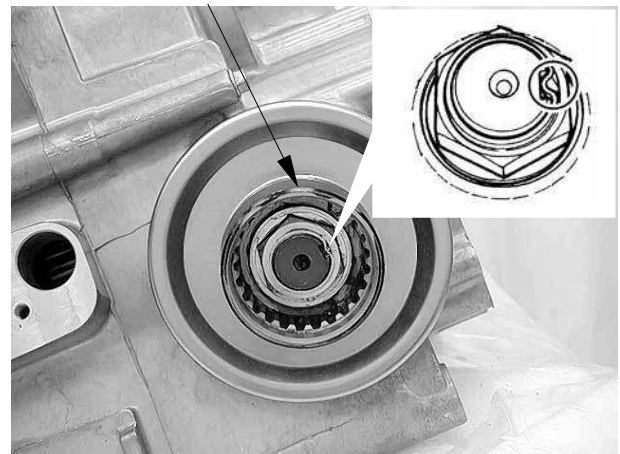

11.FINAL REDUCTION/ TRANSMISSION SYSTEM

Install the front drive shaft.
Hold universal joint nut by using a suitable bar, then remove the rear propeller shaft nut.

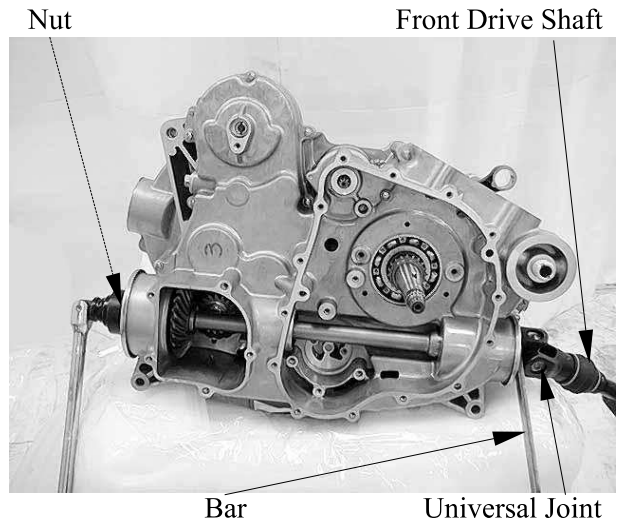

Remove the rear middle joint.

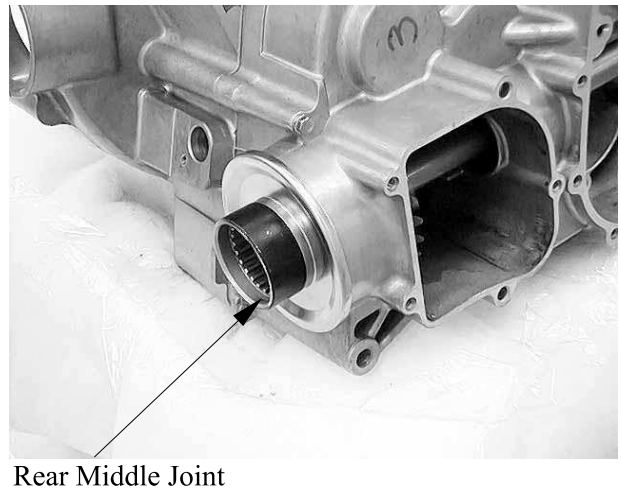

Tap the output shaft by using a rubber hammer, then remove the output shaft, secondary driven bevel gear and shim.

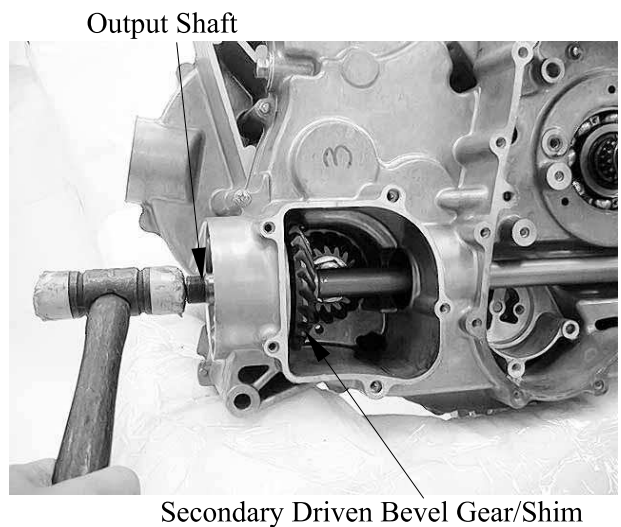

11.FINAL REDUCTION/ TRANSMISSION SYSTEM

Using a chisel, unlock the nut.

Hold the driven pulley by using the special tool (refer to the “DRIVE PULLEY, DRIVE V-BELT AND DRIVEN PULLEY REMOVAL/INSPECTION/INSTALLATION” section in the chapter 10), then remove the nut.

Special tool:

Y-type holder A120E00056

Remove the secondary drive bevel gear.

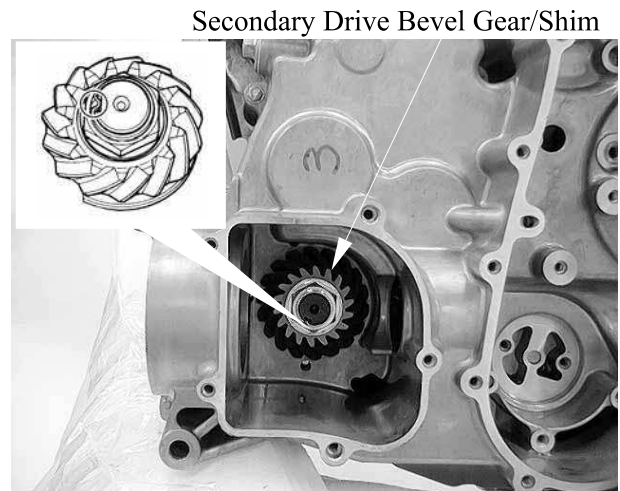

Remove the shim.

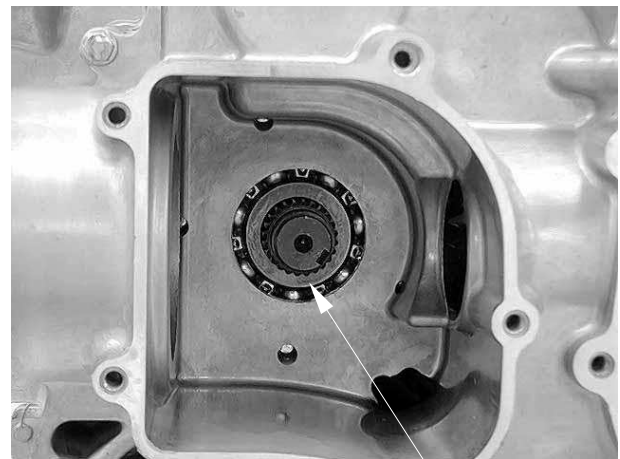

INSPECTION

Check the drive/driven bevel gear teeth for pitting, galling and wear.



11.FINAL REDUCTION/ TRANSMISSION SYSTEM

Inspect the rear middle joint splines for wear or damage.



Inspect the output shaft splines for wear or damage.



INSTALLATION

Install the shim and secondary drive bevel gear.

Holder the driven pulley by using the special tool, then install and tighten the nut to the specified torque.

Torque:

14 kgf-m (140 N-m,) Apply oil

Special tool:

Y-type holder A120E00056

Stake the nut with a center punch.

Secondary Drive Bevel Gear/Shim

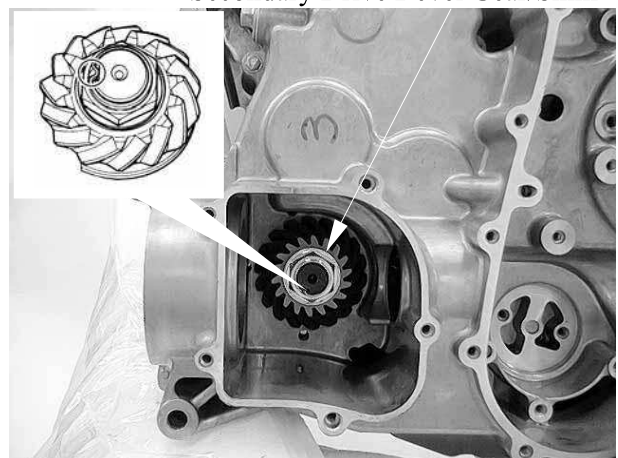

11.FINAL REDUCTION/ TRANSMISSION SYSTEM



MXU 500 IRS

Install the output shaft, secondary driven bevel gear and shim

Install the rear middle joint.

Install the front drive shaft.

Hold universal joint nut by using a suitable bar, then install and tighten the rear middle joint nut to the specified torque.

Torque:

14 kgf-m (140 N-m,) Apply oil

Remove the front drive shaft.

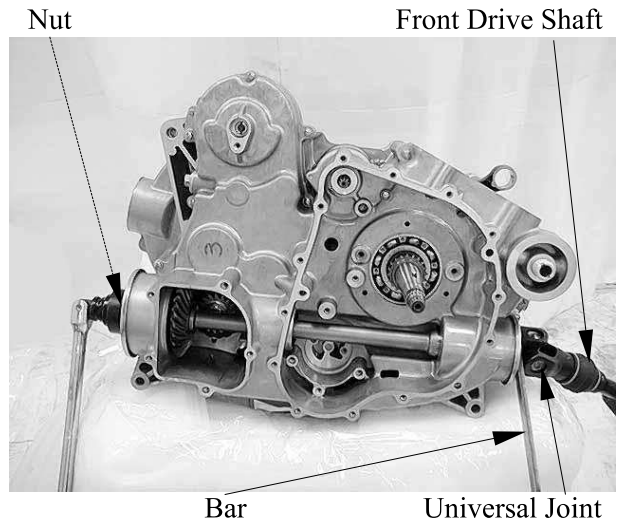

11.FINAL REDUCTION/ TRANSMISSION SYSTEM

SECONDARY GEAR SHIMS ADJUSTMENT

Set a dial gauge on the driven bevel gear as shown.

Measure the backlash by turning the rear propeller shaft in each direction, reading the total backlash on the dial gauge. If the backlash is not within specification, the shim must be changed and the backlash should be rechecked until correct. Refer to the chart for appropriate shim thickness.

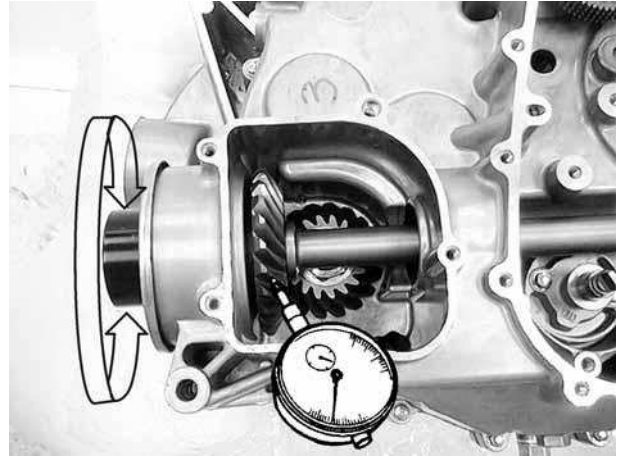

Bevel gear backlash

Standard: 0.03 - 0.15 mm

Adjust the backlash by referring to the chart at the right and using the thickness of the removed shims as a guide.

| Backlash | Shim adjustment |
|----------------|-------------------------|
| Under 0.03 mm | Decrease shim thickness |
| 0.03 – 0.15 mm | Correct |
| Over 0.15 mm | Increase shim thickness |

Drive/Driven bevel gear shims:

- A: 0.6 mm**
- B: 0.65 mm**
- C: 0.7 mm**
- D: 0.75 mm**
- E: 0.8 mm**
- F: 0.85 mm**
- G: 0.9 mm**
- H: 0.95 mm)**
- I: 1 mm**
- J: 1.05 mm**
- K: 1.1 mm**
- L: 1.15 mm**

Secondary Driven Bevel Gear Shim

Secondary Drive Bevel Gear Shim

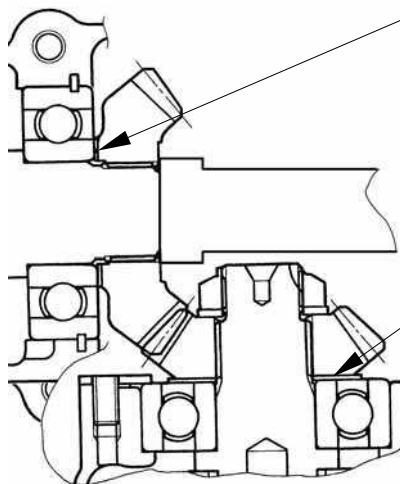

11.FINAL REDUCTION/ TRANSMISSION SYSTEM

TOOTH CONTACT

After backlash adjustment is carried out, the tooth contact must be checked. Pay attention to the following procedures:

- Remove the driven bevel gear.
- Clean and degrease several teeth of the drive and driven bevel gears.
Apply a coating of machinist's layout dye or paste to several teeth of the driven bevel gear.
- Install the driven bevel gear.
- Rotate the rear propeller shaft several turns in both directions.
- Remove the driven bevel gear and inspect the coated teeth of the drive bevel gear. The tooth contact pattern should be as shown in (1), (2) and (3).
- If tooth contact is found to be correct (example (2)), then to complete installation.

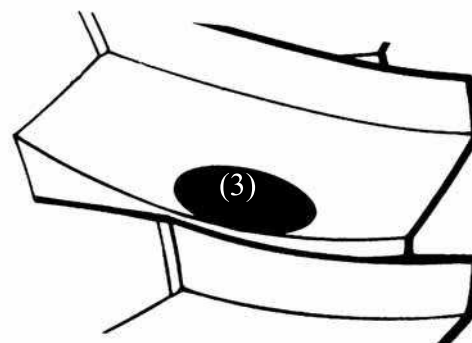
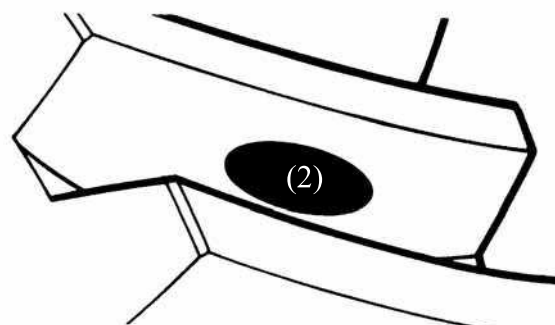
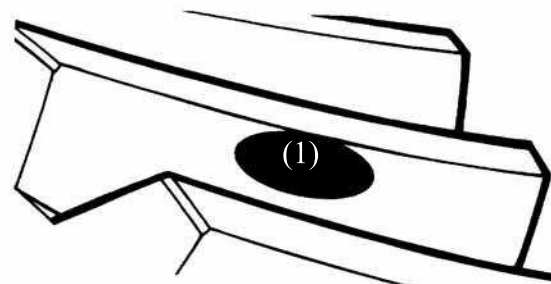

(1): Incorrect (contact at tooth top)

(2): Correct

(3): Incorrect (contact at tooth root)

- If tooth contact is found to be incorrect (examples (1) and (3)), the shim thickness between the drive bevel gear and driven bevel gear must be changed and the tooth contact rechecked until correct.

Make sure to check the backlash after the tooth contact has been adjusted, since it may have changed. Adjust the tooth contact and backlash until they are both within specification. If the correct tooth contact cannot be maintained when adjusting the backlash, replace the drive and driven bevel gears.

| Tooth contact | Drive bevel gear shim adjustment | Driven bevel gear shim adjustment |
|-----------------------|----------------------------------|-----------------------------------|
| Contact at tooth top | Increase shim thickness | Increase shim thickness |
| Contact at tooth root | Decrease shim thickness | Decrease shim thickness |

11.FINAL REDUCTION/ TRANSMISSION SYSTEM

RIGHT CRANKCASE REMOVAL/INSTALLATION

REMOVAL

Remove the cam chain (refer to the “**CAM CHAIN REMOVAL/INSPECTION/INSTALLATION**” section in the chapter 8)
Remove the secondary drive and driven bevel gear (refer to the “**SECONDARY DRIVE/DRIVEN BEVEL GEAR REMOVAL/INSPECTION/INSTALLATION**” section in this chapter).

Remove the stopper plug and washer.



Stopper Plug

Remove the spring and shift cam stopper.



Spring

Remove the four bolts from left crankcase.

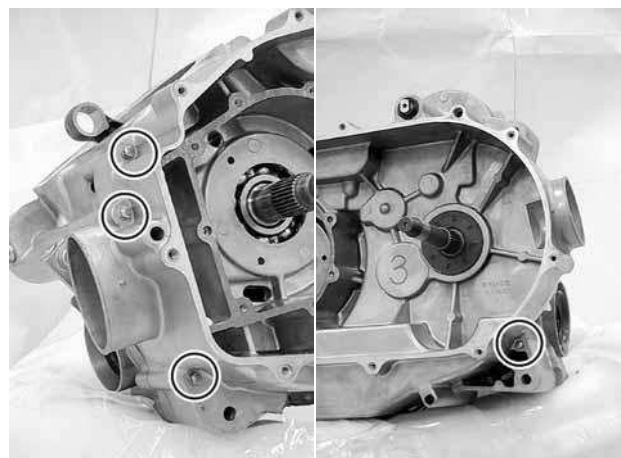

11.FINAL REDUCTION/ TRANSMISSION SYSTEM



MXU 500 IRS

Remove the fifteen bolts from right crankcase.

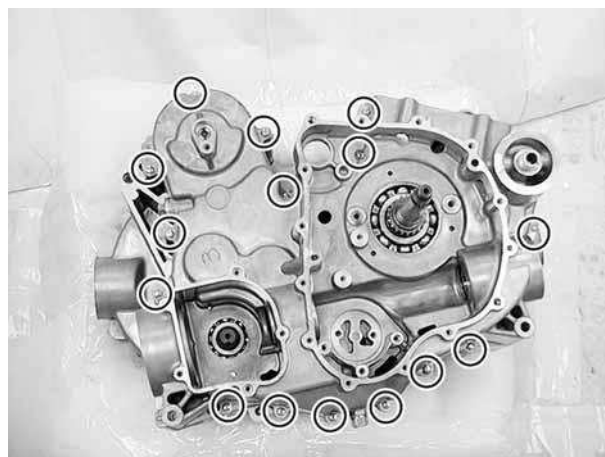

Remove the two dowel pins.

INSTALLATION

Apply a light but through coating of liquid gasket (Threebond 1215 or equivalent) to all crankcase mating surfaces except the oil passage area.

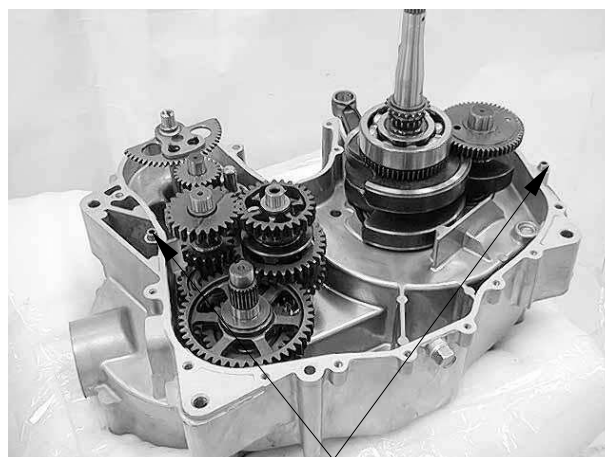

Dowel Pins

Install the right crankcase and tighten the bolts in a crisscross pattern in 2 or 3 steps.

Torque:

1.2 kgf-m (12 N-m, 8.6 lbf-ft) Apply oil

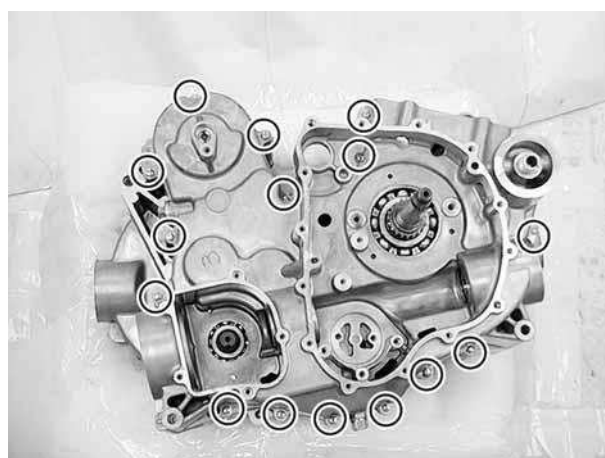

11.FINAL REDUCTION/ TRANSMISSION SYSTEM

Install and tighten the bolts in a crisscross pattern in 2 or 3 steps

Torque:

1.2 kgf-m (12 N-m,) Apply oil

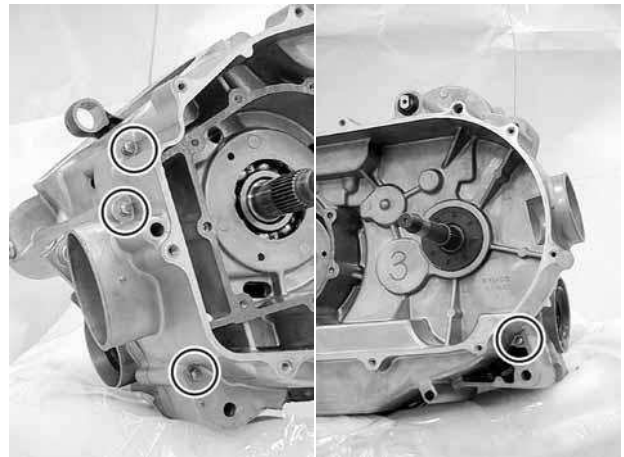

Install the stopper, spring, washer and plug.
Tighten the stopper plug to the specified torque.

Torque: 4.8 kgf-m (48 N-m)

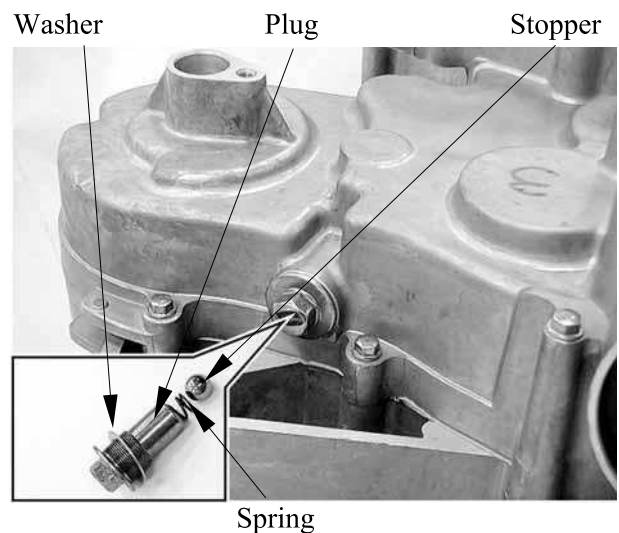

BEARING REPLACEMENT IN THE RIGHT CRANKCASE

BALANCE SHAFT/COUNTERSHAFT/ PRIMARY DRIVE SHAFT BEARING REPLACEMENT

Remove the balance
shaft/countershaft/primary drive shaft bearing
by using the special tool.

Special tool:

Bearing puller

A120E00037

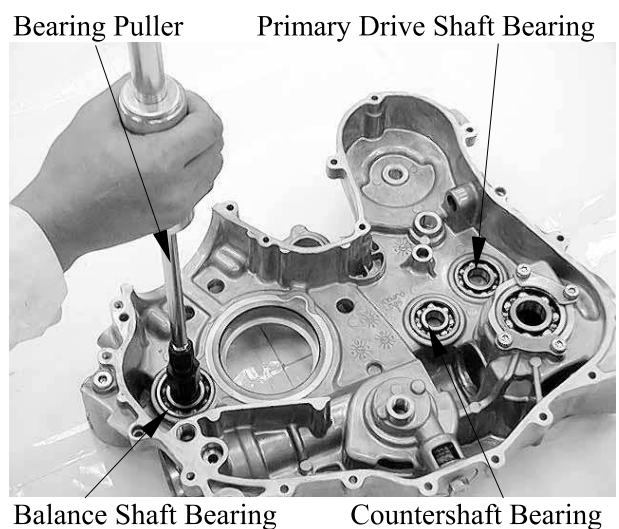

11.FINAL REDUCTION/ TRANSMISSION SYSTEM

Install the new balance shaft/countershaft/primary drive shaft bearing by using the special tool.

Special tool:

Bearing driver A120E00014

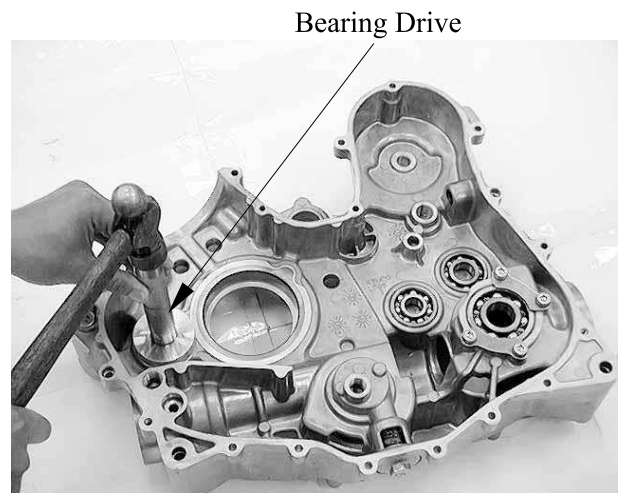

DRIVE SHAFT BEARING REPLACEMENT

Remove the four bolts and two set plates.

Remove the bearing.

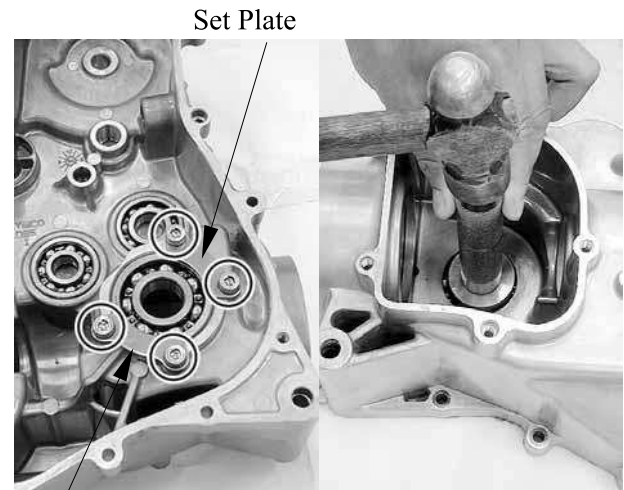

Set Plate

Install the new bearing by using the special tool.

Special tool:

Bearing driver A120E00014

Install the set plates and tighten the new bolts.

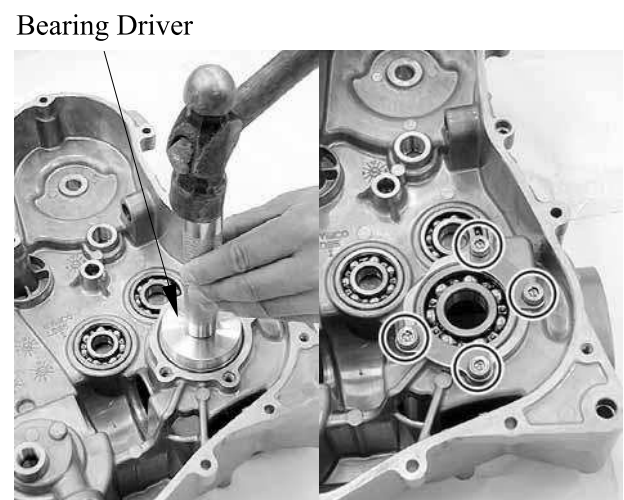

11.FINAL REDUCTION/ TRANSMISSION SYSTEM

OUTPUT SHAFT FRONT/REAR BEARING REPLACEMENT

The output shaft bearings can be replaced when the crankcase is assembly.

Rear Side Bearing

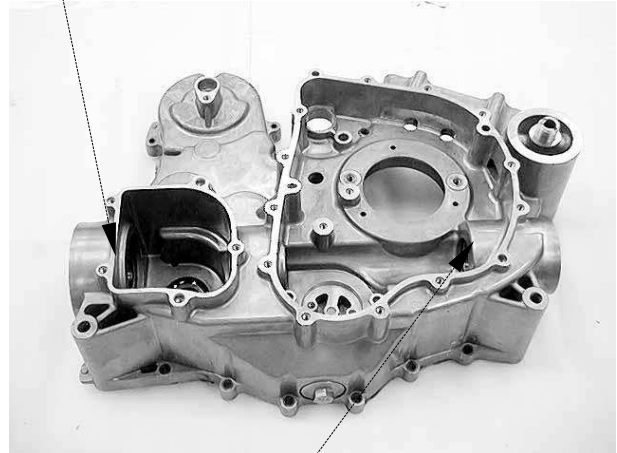

Front Side Bearing

REAR SIDE BEARING

Remove the oil seal.

Remove the nut by using the special tool.

Special tool:

Nut wrench

A120E00066

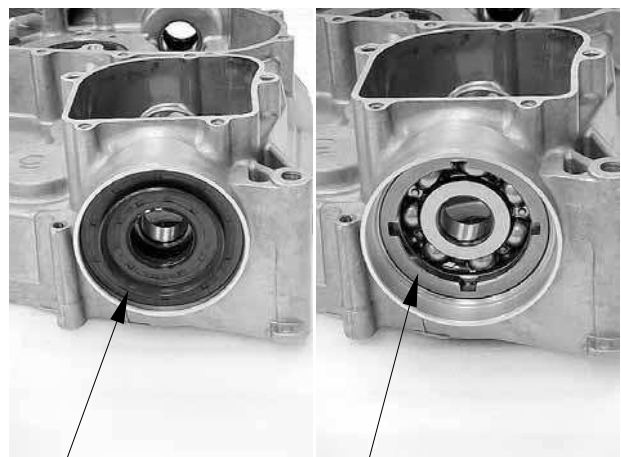

Oil Seal

Nut

Remove the bearing by using the special tool.

Special tool:

Bearing Puller

A120E00037

Install the new bearing.

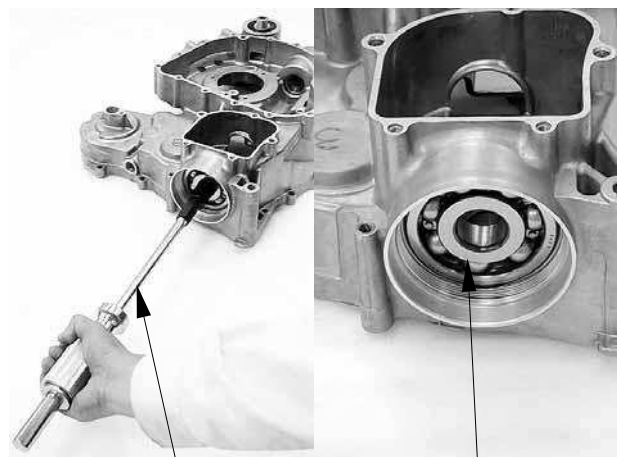

Bearing Puller

Bearing

11.FINAL REDUCTION/ TRANSMISSION SYSTEM

Install and tighten the nut to the specified torque by using the special tool.

Torque: 11 kgf-m (110 N-m)

Special tool:

Nut wrench A120E00066

Apply clean engine oil to the new oil seal lip then install the oil seal.

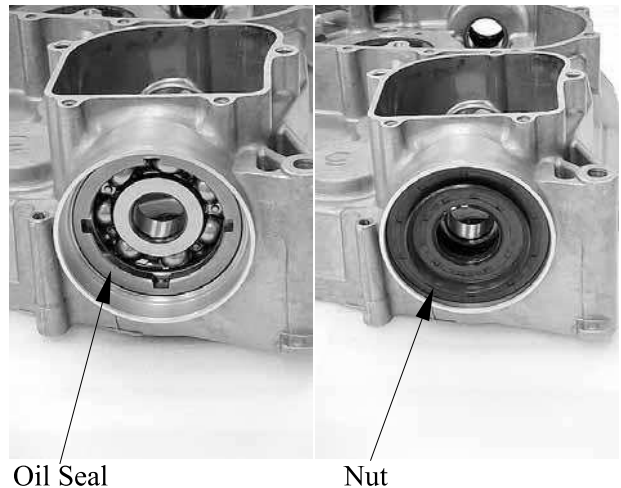

FRONT SIDE BEARING

Remove the oil seal.

Remove the snap ring.

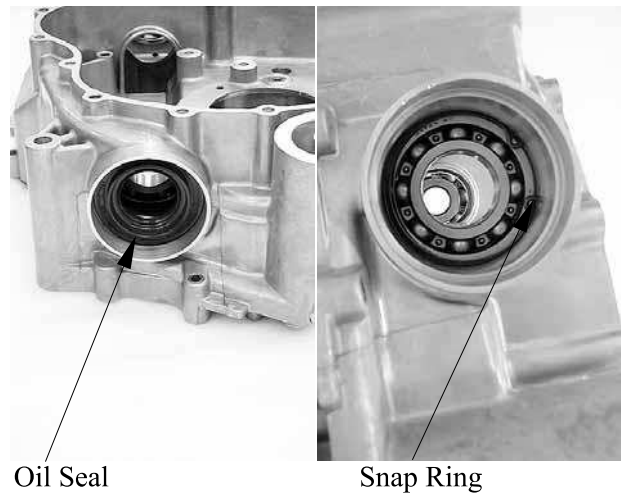

Remove the bearing by using the special tool.

Special tool:

Bearing Puller A120E00037

Install the new bearing by using the special tool.

Special tool:

Bearing driver A120E00014

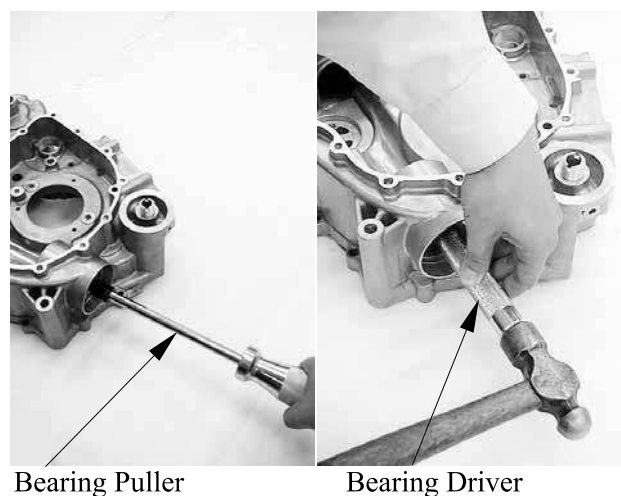

11.FINAL REDUCTION/ TRANSMISSION SYSTEM

Install the snap ring.

Apply clean engine oil to the new oil seal lip
then install the new seal.

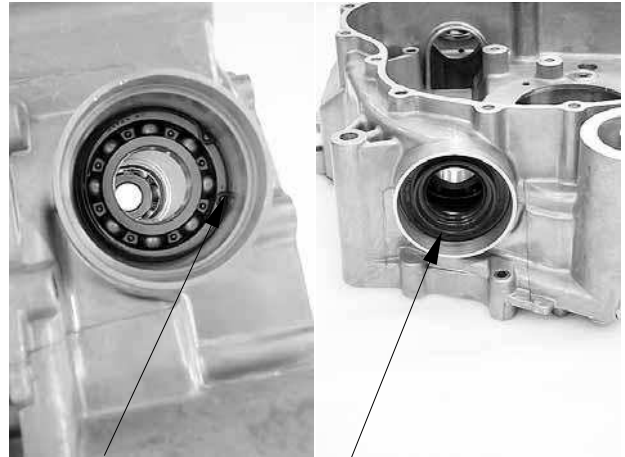

Snap Ring

Oil Seal

11.FINAL REDUCTION/ TRANSMISSION SYSTEM



MXU 500 IRS

TRANSMISSION REMOVAL/INSPECTION/ INSTALLATION

REMOVAL

Remove the bolt and then remove the shift arm.

Remove the right crankcase (refer to the “**RIGHT CRANKCASE REMOVAL/INSTALLATION**” section in this chapter)

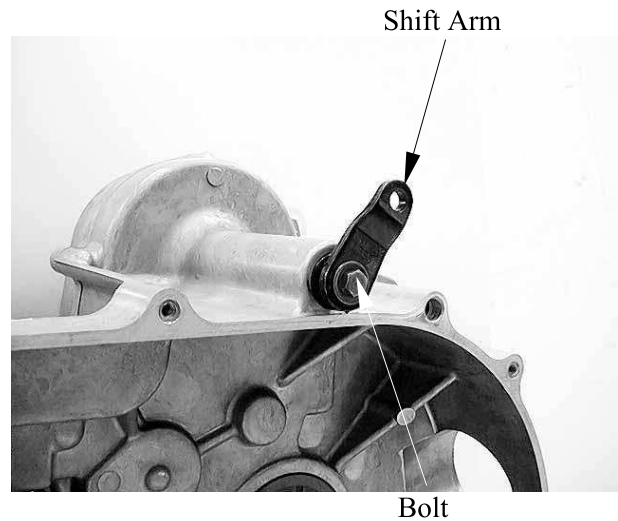

Remove the shift shaft.

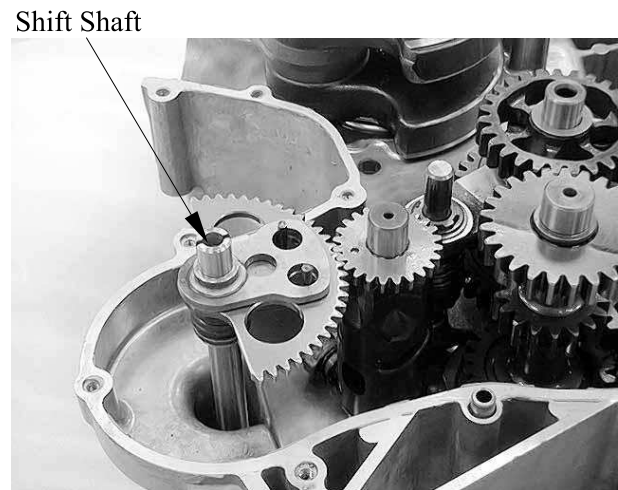

Remove the transmission guide bar.



11.FINAL REDUCTION/ TRANSMISSION SYSTEM

Remove the upper shift fork.
Remove the lower shift fork.

Upper Shift Fork



Lower Shift Fork



Remove the shift cam.

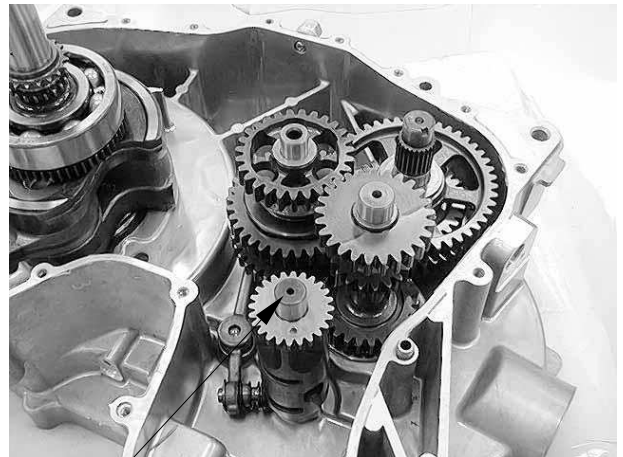

Shift Cam

Remove the countershaft and driveshaft as an assembly.

Disassemble the countershaft and the driveshaft.

Keep track of the disassembled parts (gears, washer and clip) by stacking them on a tool or slipping them onto a piece of wire.

Countershaft Assembly

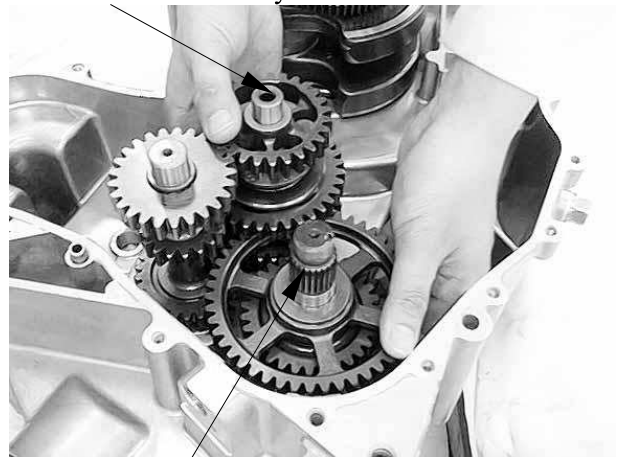

Driveshaft Assembly

11.FINAL REDUCTION/ TRANSMISSION SYSTEM

Remove the primary drive shaft.

Primary Drive Shaft

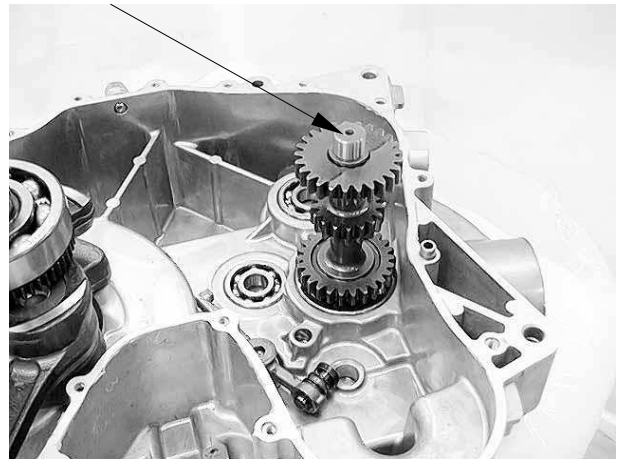

Remove the bolt/washer, then remove the stopper lever and spring.

Spring

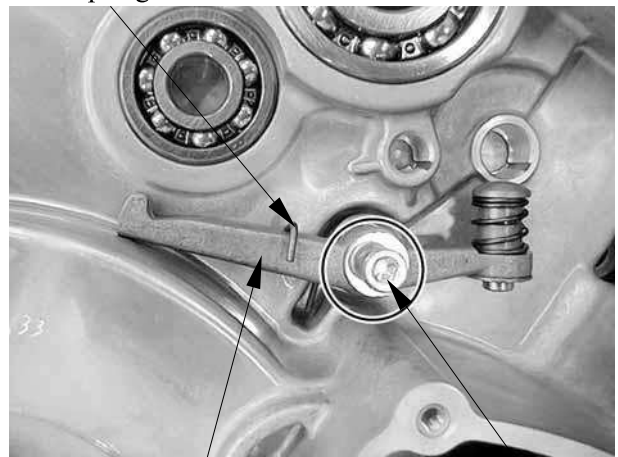

Stopper Lever

Bolt/Washer

INSPECTION

Guide bar

Measure the guide bar runout.
Out of specification → Replace.

Service Limit:

Less than 0.03 mm (0.0012 in)

Do not attempt to straighten a bent guide bar.

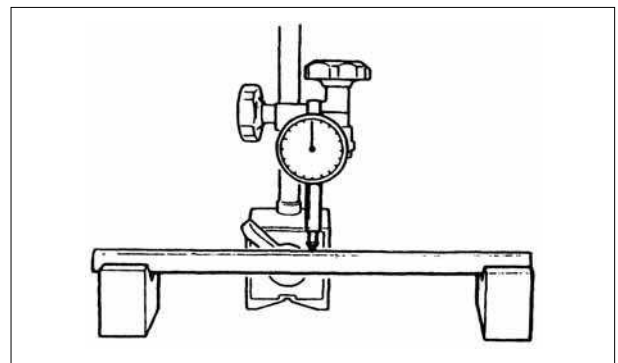

11.FINAL REDUCTION/ TRANSMISSION SYSTEM

Upper shift fork

Inspect the shift fork cam follower and shift fork pawl.
Scoring/beads/wear → Replace a set.

Inspection the spring.
Cracks or damage → Replace a set..

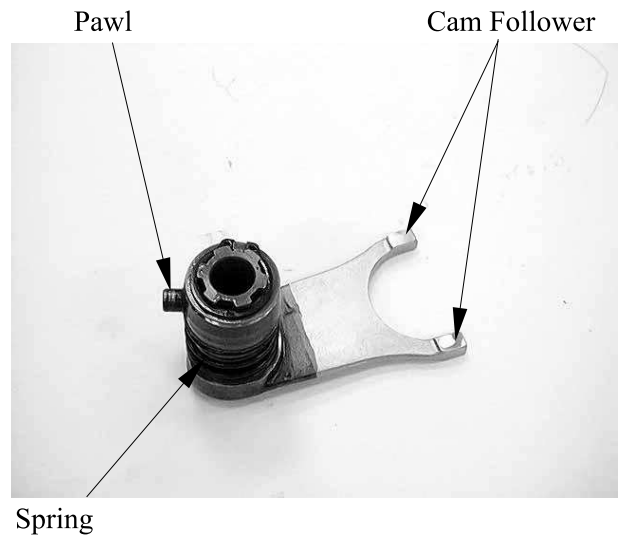

Lower shift fork

Inspect the shift fork cam follower and shift fork pawl.
Scoring/beads/wear → Replace.

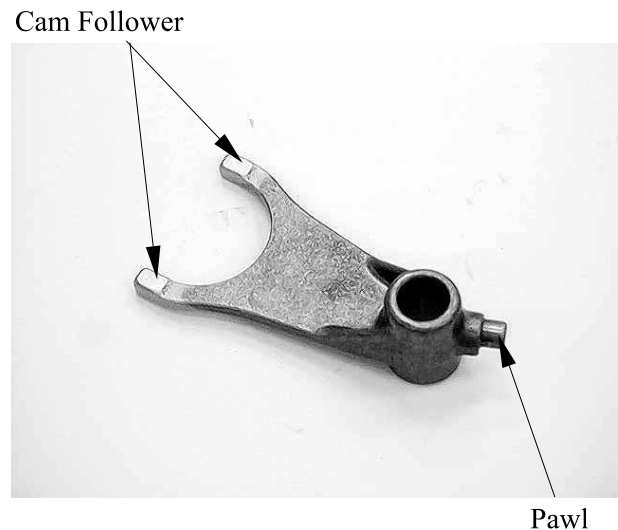

Primary drive shaft

Check the gear teeth for blue discoloration, pitting or wear.



11.FINAL REDUCTION/ TRANSMISSION SYSTEM

Stopper lever

Check the stopper lever pawl for bends, damage or wear.

Inspect the spring for cracks or damage.



Check the shift cam groove and shift cam gear.

Wear or damage → Replace.



Inspect shift shaft gear.

Damage → Replace.

Inspect shift shaft.

Damage/bends/wear → Replace.

Check the return spring for fatigue or damage.



11.FINAL REDUCTION/ TRANSMISSION SYSTEM

INSTALLATION

Make sure the shaft nut specified torque in the V-belt compartment while holds the stopper lever shaft.

Torque: 3 kgf-m (30 N-m, 21.6 lbf-ft)

Stopper Lever Shaft

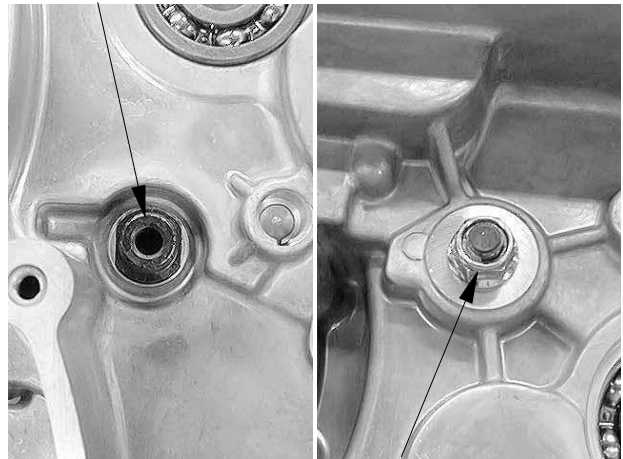

Nut

Hook the spring onto the hook part of the stopper lever, squeeze the spring in to the groove of the left crankcase.

Stopper Lever

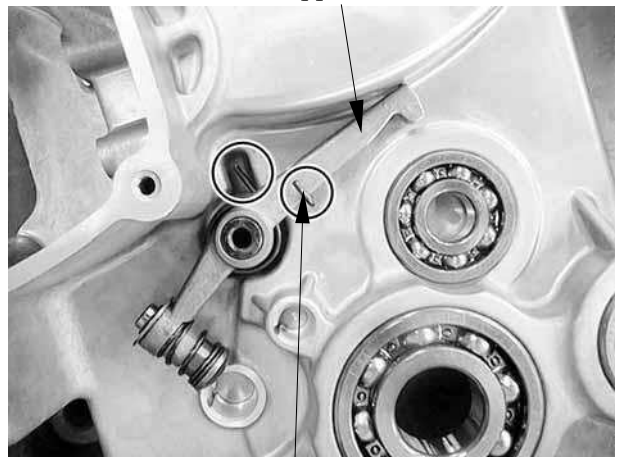

Spring

Install the washer and a new bolt.
Tighten the bolt to the specified torque while holds the shaft nut in the drive V-belt compartment.

Torque: 2.5 kgf-m (25 N-m, 18 lbf-ft)

Bolt/Washer

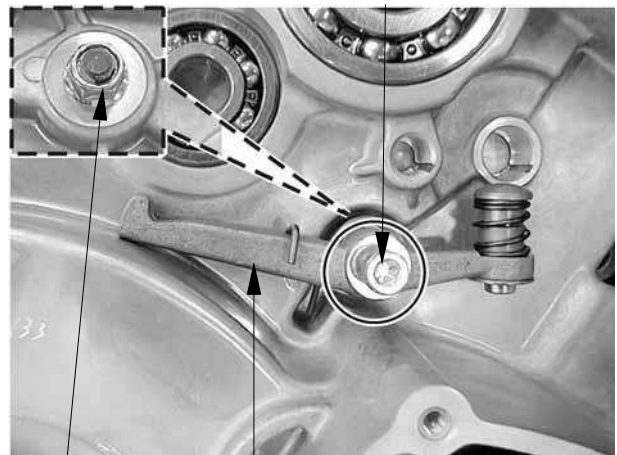

Shaft Nut

Stopper Lever

11.FINAL REDUCTION/ TRANSMISSION SYSTEM

Apply clean engine oil to the countershaft assembly, driveshaft assembly and primary drive shaft.

Install the primary drive shaft.
Install the countershaft and drive shaft assemblies as a set into the left crankcase.

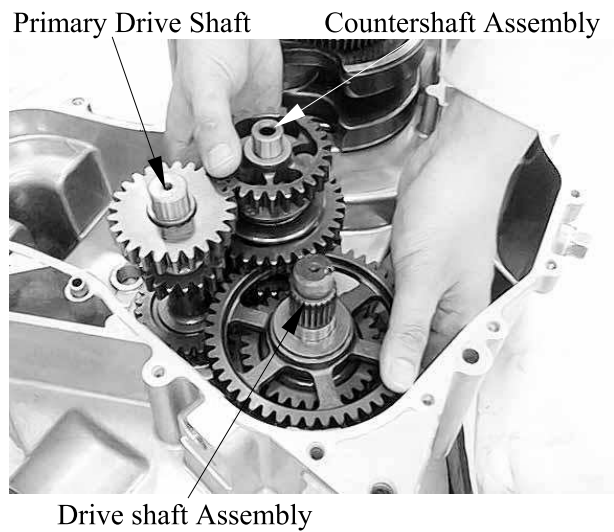

Apply clean engine oil to the shift cam, then install the shift cam.

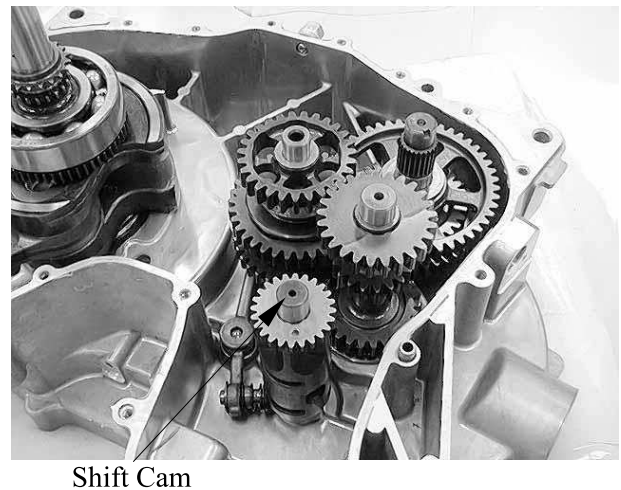

Apply clean engine oil to the gearshift fork, sliding surface and gearshift fork pawl.

Install the lower gearshift fork into the clutch dog (countershaft) and shift cam grooves with its "LDB5" mark facing down.

Install the upper gearshift fork into the clutch dog (countershaft) and shift cam grooves with its "LDB5" mark facing up.

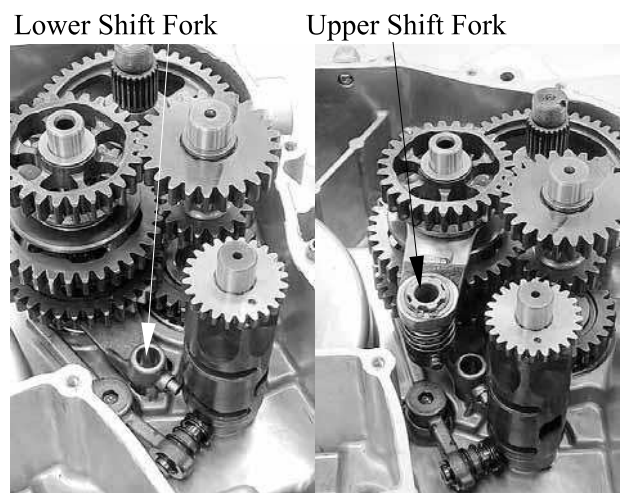

11.FINAL REDUCTION/ TRANSMISSION SYSTEM

Apply clean engine oil to the guide bar,
install the guide bar.

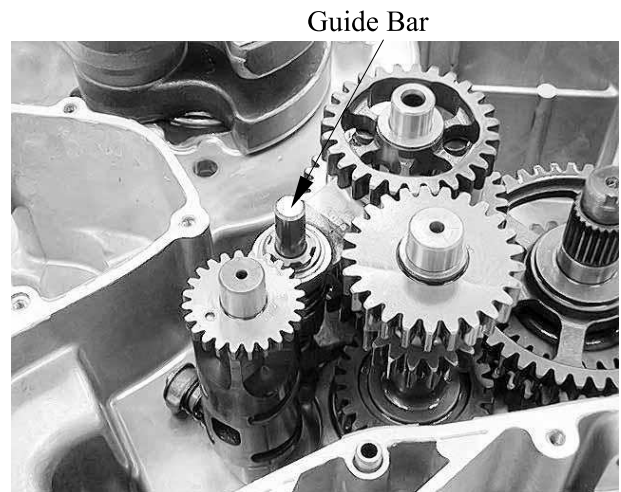

Install the shift shaft.

Align the mark on the shift shaft gear
with the mark on the shift cam gear.

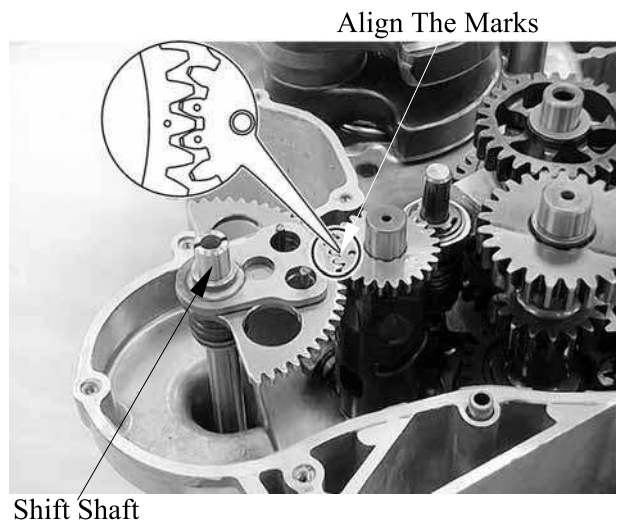

Check the transmission operation.
Unsmooth operation → Repair.



11.FINAL REDUCTION/ TRANSMISSION SYSTEM

UPPER SHIFT FORK DISASSEMBLY/ASSEMBLY

DISASSEMBLY

Remove the upper shift fork (refer to the “TRANSMISSION REMOVAL/INSPECTION/ INSTALLATION” section in this chapter)

Remove the snap ring, washer and fork.

Remove the spring, cam pawl and washer.

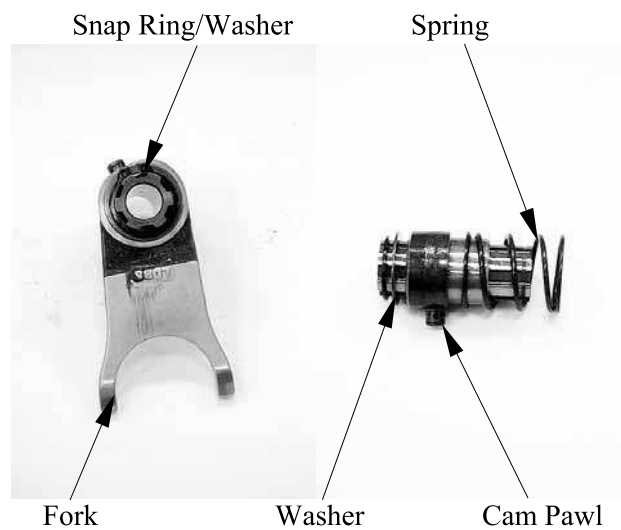

ASSEMBLY

Install the washer and cam pawl.

Align the mark on the cam pawl with the mark on the shaft.

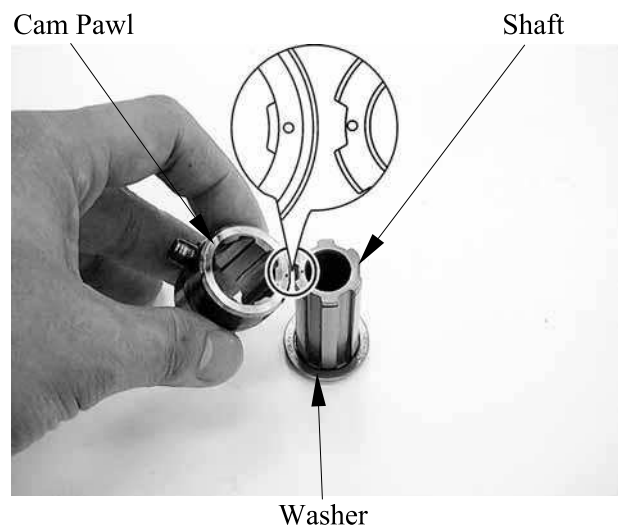

Install the spring.

Install the fork.

Align the mark on the fork with the mark on the shaft.

Install the washer and snap ring.

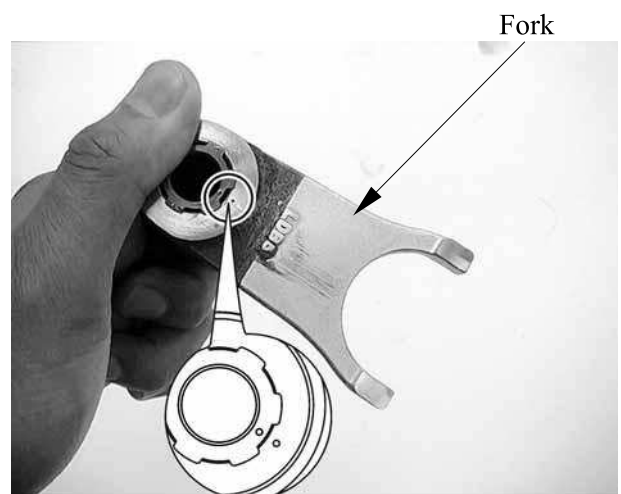

11.FINAL REDUCTION/ TRANSMISSION SYSTEM

DRIVE SHAFT DISASSEMBLY/ASSEMBLY/ INSPECTION

DISASSEMBLY

Remove the drive shaft assembly (refer to the “TRANSMISSION REMOVAL/INSPECTION/ INSTALLATION” section in this chapter).

Remove the washer (thick) and reverse gear.

Remove the washer (thin).

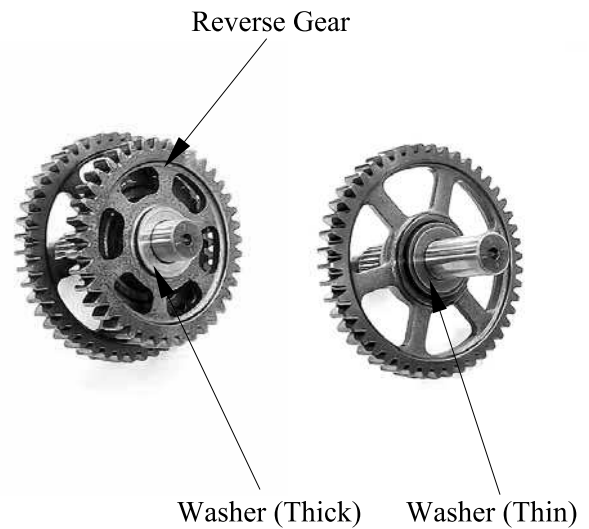

ASSEMBLY/INSPECTION

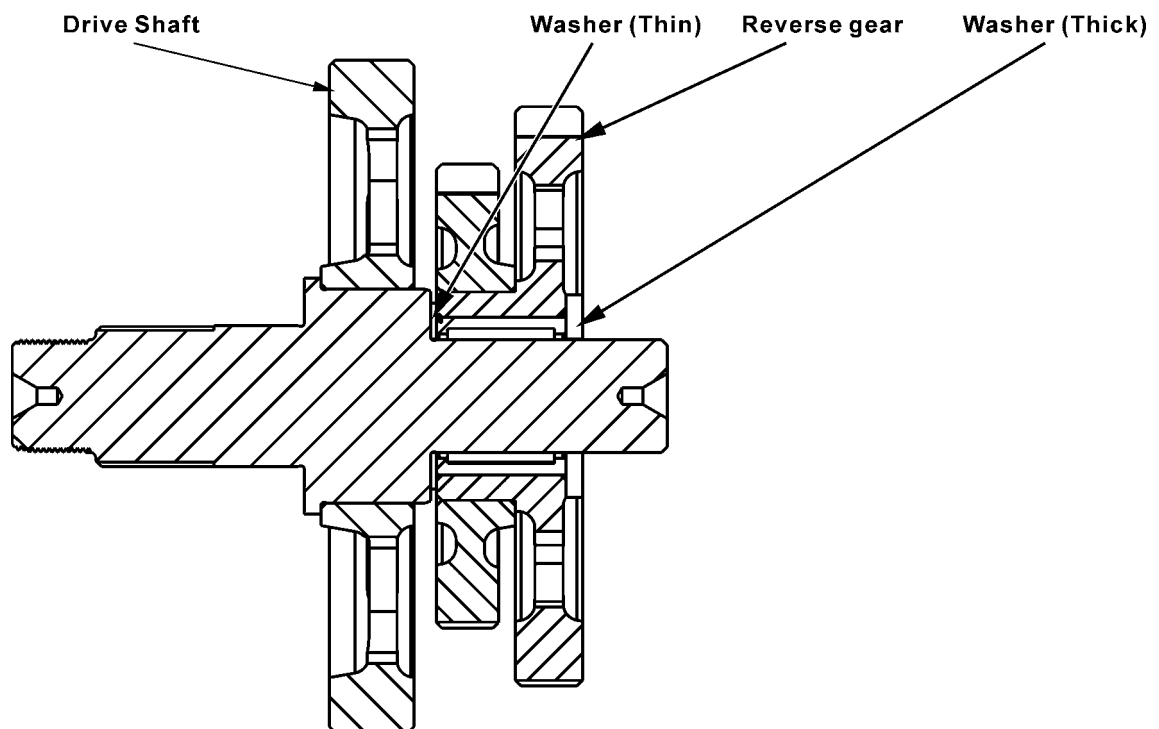

Inspect the gear teeth.
Blue discoloration/pitting/wear → Replace.

Inspect the needle bearing in the reverse gear.
Wear/damage → Replace.

11.FINAL REDUCTION/ TRANSMISSION SYSTEM

COUNTERSHAFT DISASSEMBLY/ASSEMBLY/ INSPECTION

DISASSEMBLY

Remove the countershaft assembly (refer to the “TRANSMISSION REMOVAL/INSPECTION/ INSTALLATION” section in this chapter).

Remove the washer and high drive gear.

Remove the high/low gear clutch dog

Remove the clip, then remove the washer and low drive gear.

Remove the clip, then remove the stopper wheel.

Remove the clip, then remove reverse gear clutch dog.

Remove the clip, then remove the washer and reverse drive gear.

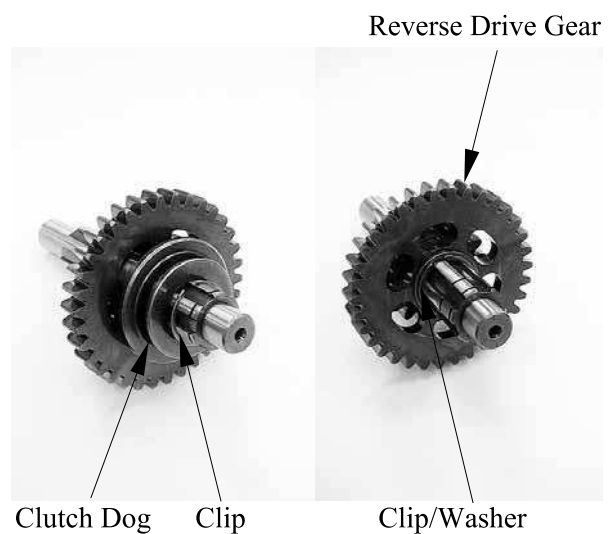
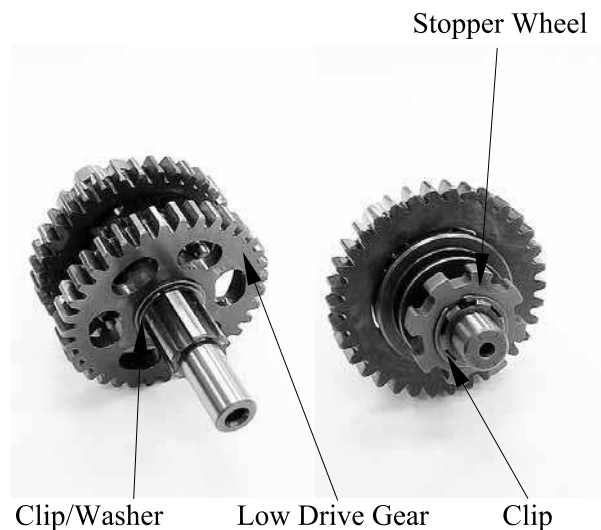
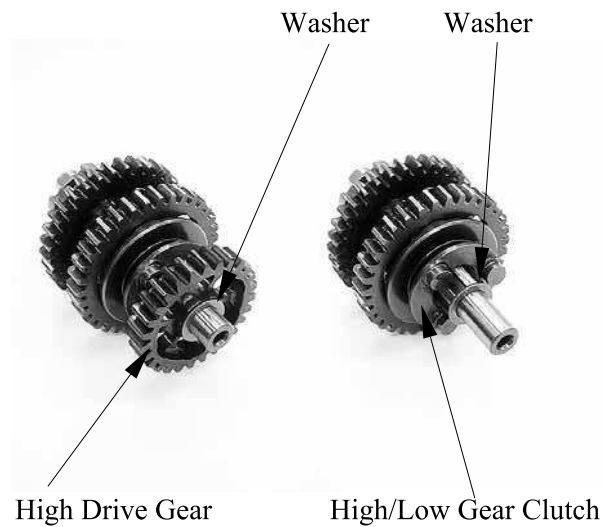

11.FINAL REDUCTION/ TRANSMISSION SYSTEM

ASSEMBLY/INSPECTION

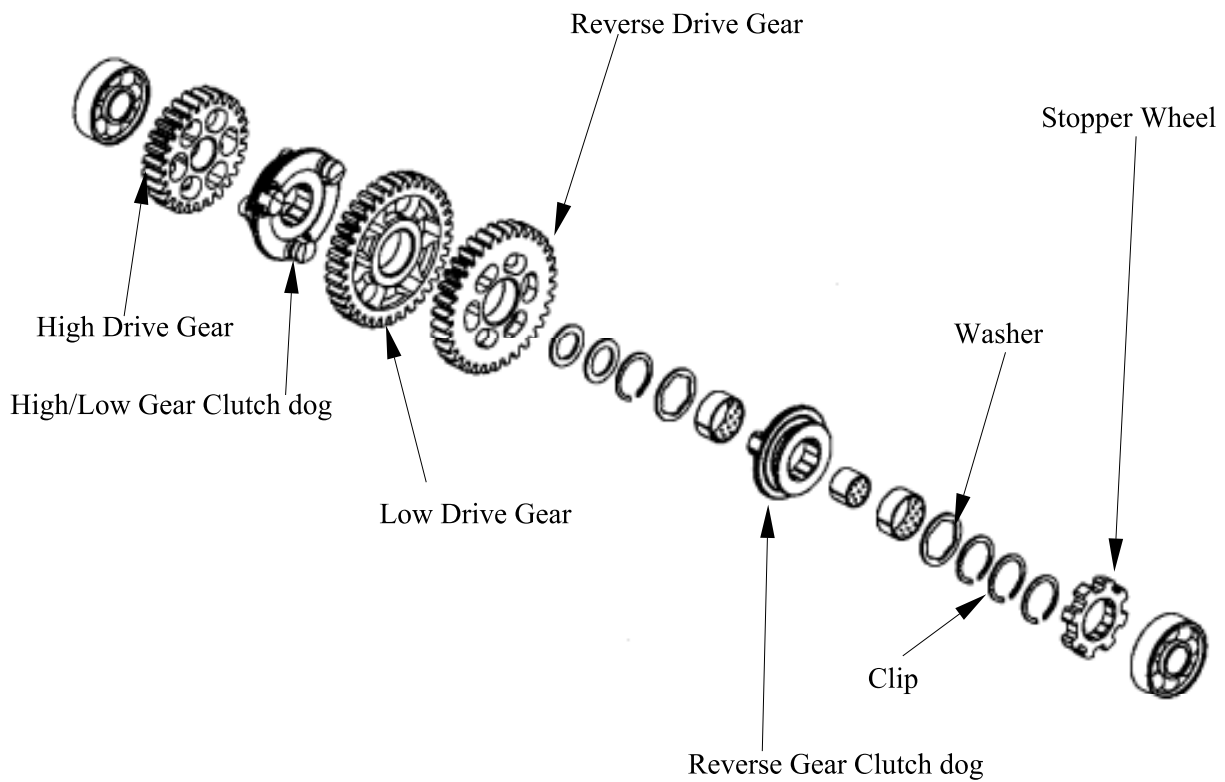

Inspect the gear teeth.
Blue discoloration/pitting/wear → Replace.

Inspect the mated dogs.
Rounded edges/cracks/missing portions
→ Replace.

**12.LEFT CRANKSCASE/CRANKSHAFT/
BALANCE SHAFT**

MXU 500 IRS

**LEFT CRANKCASE/CRANKSHAFT/
SHAFT**

BALANCE

SERVICE INFORMATION----- 12- 2
TROUBLESHOOTING----- 12- 2
CRANK SHAFT AND BALANCE SHAFT
REMOVAL/INSPECTION/INSTALLATION ----- 12- 3
BEARING/OIL SEAL REPLACEMENT IN THE LEFT
CRANKCASE----- 12- 6

**12.LEFT CRANKCASE/CRANKSHAFT/
BALANCE SHAFT**

MXU 500 IRS

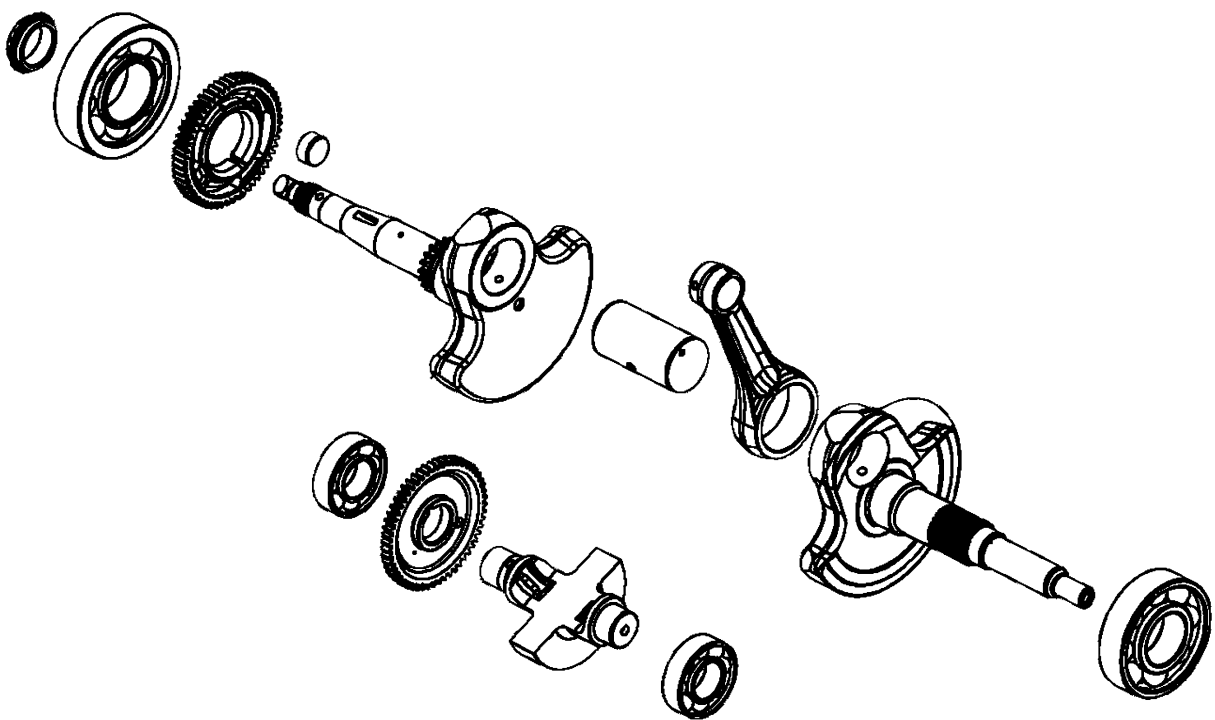

12.LEFT CRANKSCASE/CRANKSHAFT/ BALANCE SHAFT

MXU 500 IRS

SERVICE INFORMATION

GENERAL INSTRUCTIONS

- This section covers crankcase separation to service the crankshaft. The engine must be removed for this operation.
- The following parts must be removed before separating the crankcase.
 - Cylinder head (⇒Chapter 8)
 - Cylinder/piston (⇒Chapter 9)
 - Drive and driven pulleys (⇒Chapter 10)
 - A.C. generator (⇒Chapter 17)
 - Starter clutch (⇒Chapter 19)
 - Oil pump (⇒Chapter 4)

SPECIFICATIONS

Unit: mm (in)

| | Item | | Standard | Service Limit |
|------------|---|--------------|----------------------------|---------------|
| Crankshaft | Connecting rod big end side clearance | Not USA type | 0.01 ~ 0.4 (0.002 ~ 0.016) | 0.6 (0.024) |
| | | USA type | 0.3 ~ 0.6 (0.012 ~ 0.024) | 0.8 (0.032) |
| | Connecting rod big end radial clearance | | 0 ~ 0.008 (0 ~ 0.00032) | 0.05 (0.002) |
| | Run out | | — | 0.1 (0.004) |

TROUBLESHOOTING

Excessive engine noise

Excessive bearing play

12.LEFT CRANKCASE/CRANKSHAFT/ BALANCE SHAFT

MXU 500 IRS

CRANKSHAFT AND BALANCE SHAFT REMOVAL/INSPECTION/ INSTALLATION

REMOVAL

Remove the right crankcase (refer to the “**RIGHT CRANKCASE REMOVAL/INSTALLATION**” section in the chapter 11).

Remove the crankshaft and balance shaft together.

INSPECTION

Balance shaft

Inspect the balance shaft gear teeth.
Burr/chips/roughness/wear → Replace.

Crankshaft inspection

Inspect the crankshaft gear teeth.
Burr/chips/roughness/wear → Replace.

Measure the connecting rod small end I.D.

Service Limit (replace if over):
22.06 mm (0.8824 in)

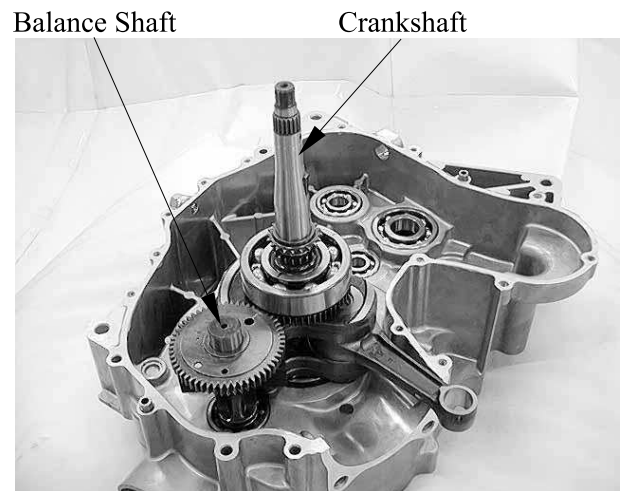

12.LEFT CRANKSCASE/CRANKSHAFT/ BALANCE SHAFT

MXU 500 IRS

Measure the connecting rod small end free play (A).

Out of specification:

0.8 ~ 1 mm (0.032 ~ 0.04 in)

→ Replace the crankshaft.

Measure the crankshaft run out (B).

Service Limit (replace if over):

0.1 mm (0.004 in)

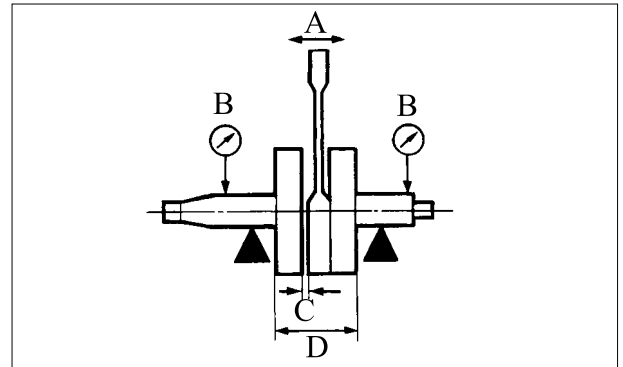

Measure the connecting rod big end side clearance (C).

Service Limit (replace if over):

Not USA type: 0.6 mm (0.024 in)

USA type : 0.8 mm (0.032 in)

Measure the crank width (D).

Out of specification:

72 ~ 72.05 mm (2.88 ~ 2.882 in)

→ Replace the crankshaft.

Turn the crankshaft bearings and check for excessive play.

Measure the crankshaft bearing play.

Service Limit (replace if over):

Axial : 0.2 mm (0.008 in)

Radial : 0.05 mm (0.002 in)

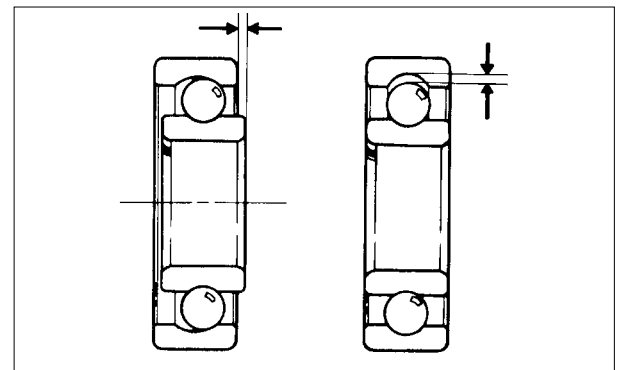

12.LEFT CRANKCASE/CRANKSHAFT/ BALANCE SHAFT

MXU 500 IRS

INSTALLATION

Install the balance shaft and crankshaft into the left crankcase.

- * Align the mark on the balance shaft with the mark on the crankshaft.

Mark (on the Balance Shaft)

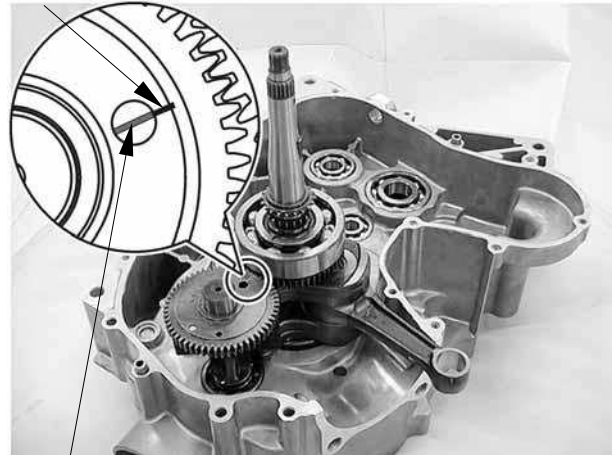

Mark (on the Crankshaft)

12.LEFT CRANKSCASE/CRANKSHAFT/ BALANCE SHAFT

MXU 500 IRS

BEARING/OIL SEAL REPLACEMENT IN THE LEFT CRANKCASE

BALANCE SHAFT/COUNTERSHAFT/ PRIMARY DRIVE SHAFT/BALANCE SHAFT BEARING REPLACEMENT

Remove the balance shaft/countershaft/primary drive shaft /drive shaft bearing by using the special tool.

Special tool:

Bearing puller A120E00037

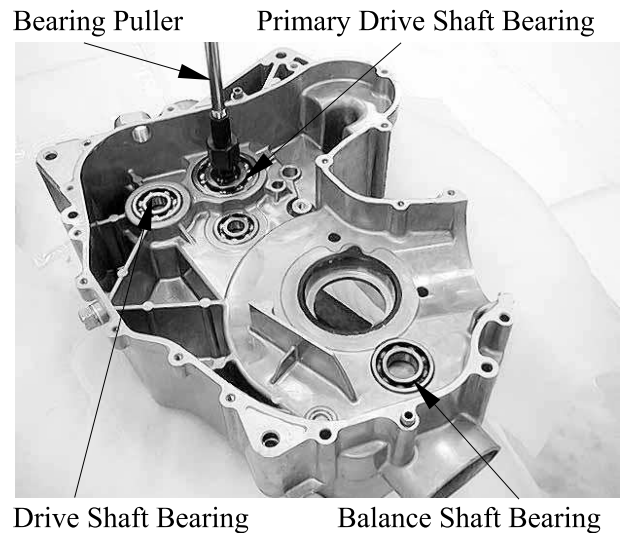

Install the new bearing by using the special tool.

Special tool:

Bearing driver A120E00014



Check the oil seals
Wear or damage → replace

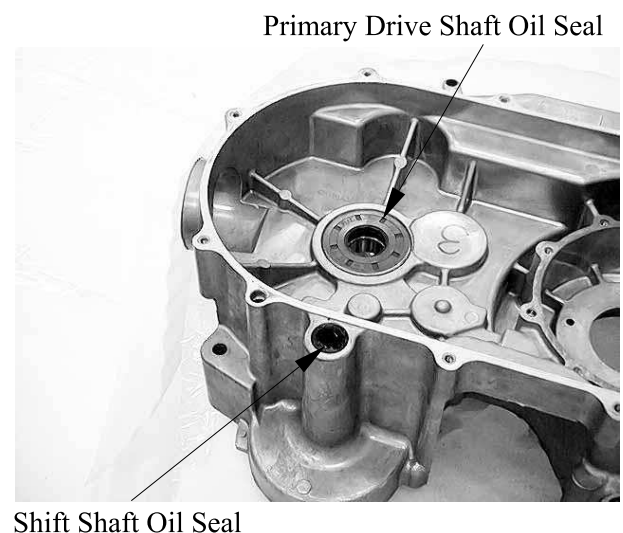

DRIVE TRAIN

| | |
|---|-------|
| SERVICE INFORMATION----- | 13- 2 |
| TROUBLESHOOTING----- | 13- 2 |
| FRONT ASSY CVJ REMOVAL/INSPECTION/ INSTALLATION ----- | 13- 3 |
| FRONT ASSY CVJ DISASSEMBLY/INSPECTION/ ASSEMBLY ----- | 13- 5 |
| FRONT GEAR CASE REMOVAL/INSPECTION/INSTALLATION - | 13-11 |
| FRONT GEAR CASE DISASSEMBLY/INSPECTION/ASSEMBLY | 13-14 |
| REAR ASSY GEAR CASE REMOVAL/INSPECTION/ INSTALLATION ----- | 13-19 |

13. DRIVE TRAIN

FRONT DRIVE

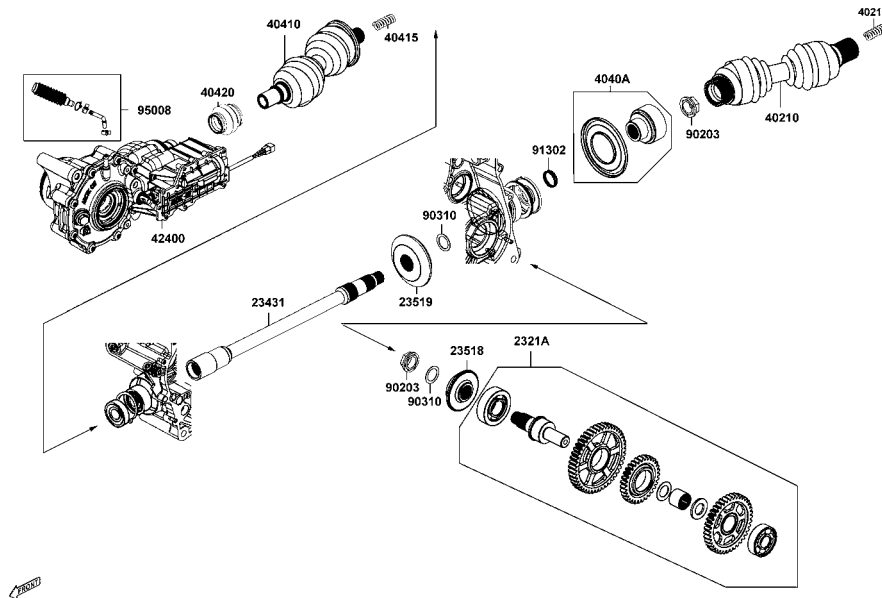

REAR DRIVE

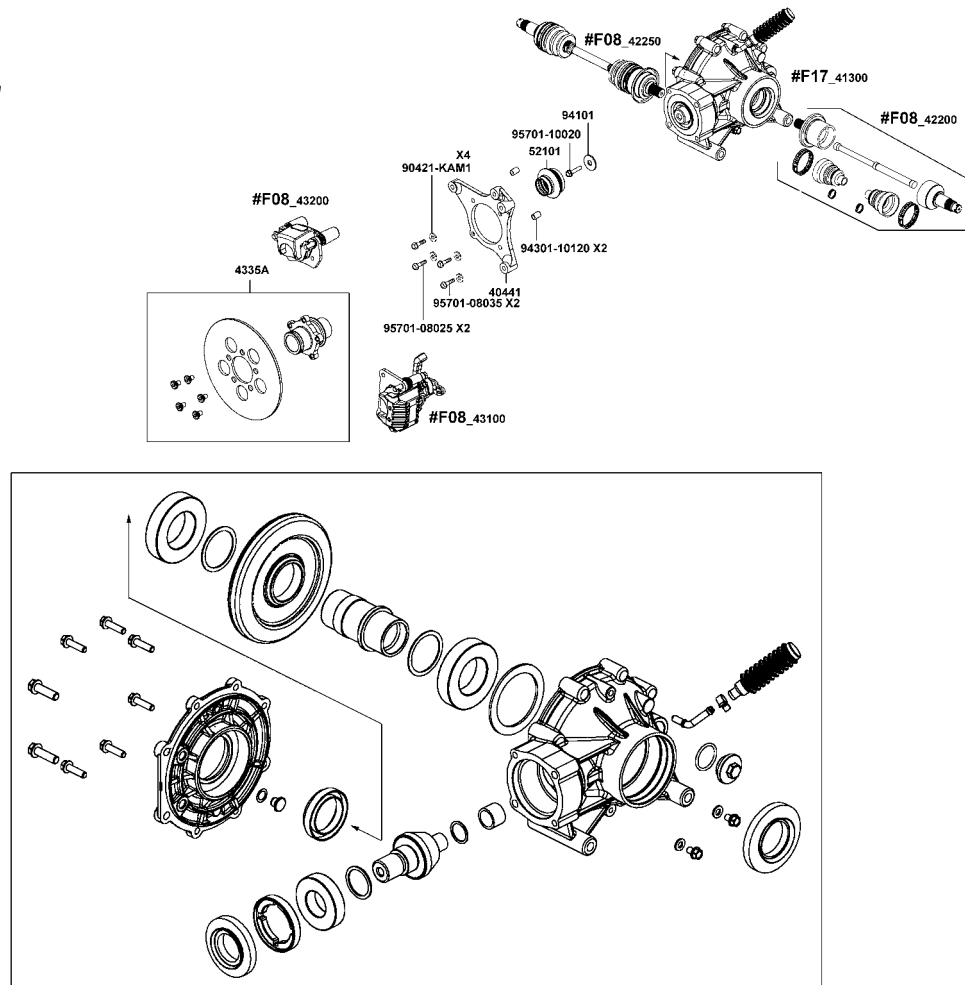

41300

13. DRIVE TRAIN

SERVICE INFORMATION

GENERAL INSTRUCTIONS

- Too little backlash is extremely destructive to the gear teeth. If a test ride following reassembly indicates this condition, stop riding immediately to minimize gear damage.
- Stop riding immediately if broken gear teeth are suspected. This condition could result in the shaft drive assembly locking up, causing loss of control of the machine and possible injury to the rider.
- An apparent oil leak on a new or nearly new machine may be the result of a rust-preventative coating or excessive seal lubrication.
- Always clean the machine and recheck the suspected location of an apparent leakage.

TORQUE VALUES

| | |
|--|---|
| Front drive gear case mounting bolt | 4 kgf-m (40 Nm, 29 lbf-ft) |
| Front propeller shaft bolt | 4.5 kgf-m (45 N-m, 32.4 lbf-ft) |
| Shifting fork shaft plug | 1.5 kgf-m (15 N-m, 11 lbf-ft) Apply threebond: 1215 |
| Front drive gear case bolt | 2.3 kgf-m (23 N-m, 16.5 lbf-ft) Apply threebond: 1215 |
| 2WD/4WD shift motor mounting bolt (M8) | 2.3 kgf-m (23 N-m, 16.5 lbf-ft) Apply threebond: 1215 |
| 2WD/4WD shift motor mounting bolt (M6) | 1.2 kgf-m (12 N-m, 8.5 lbf-ft) |
| Rear drive gear case mounting nut | 5.5 kgf-m (55 Nm, 40 lbf-ft) |
| Rear drive gear case bolt (M10) | 5 kgf-m (49 N-m, 36 lbf-ft) Apply threebond: 1215 |
| Rear drive gear case bolt (M8) | 2.5 kgf-m (25 N-m, 19 lbf-ft) Apply threebond: 1215 |

SPECIAL TOOLS

| | |
|-------------------------|---------------|
| A120E00014 | |
| Bearing puller | A120E00037 |
| Joint yoke remover | A120F00016 |
| Yoke bearing puller | A120F00018 |
| Pinion gear puller | A120F00026 |
| Bearing lock nut wrench | A120F00020/25 |

TROUBLESHOOTING

- 1. A pronounced hesitation movement during acceleration, deceleration, or sustained speed. (This must not be confused with engine surging or transmission characteristics.)**
- 2. A “rolling rumble” noticeable at low speed; a high-pitched whine from front drive component or area.**
- 3. A locked-up condition of the shaft drive train mechanism, no power transmitted from the engine to the front and /or rear wheel.**
 - Bearing damage
 - Improper backlash
 - Gear tooth damage
 - Broken propeller shaft
 - Broken gear teeth
 - Seizure due to lack of lubrication
 - Small foreign objects lodged between the moving parts.

FRONT DRIVE SHAFT REOMVAL/INSPECTION/ INSTALLATION

REMOVAL

Remove the steering knuckle (refer to the “**STEERING KNUCKLE REMOVAL/INSPECTION/INSTALLATION**” section in the chapter 14).

Remove the front CVJ ASSY from front ASSY gear case.

SIEP 1:Drain gear oil

SIEP 2:Pushing and pulling the front ASSY CVJ from front ASSY gear case .

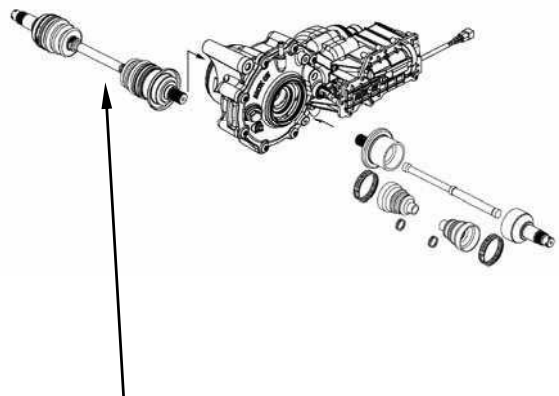

Front CVJ ASSY

INSPECTION

Inspect the boots, circlip and boot bands for wear or damage.

If any damages are found, replace them with new ones.

Inspect the double off-set joint spline for wear or damage.

If any damages are found, replace them with new ones.

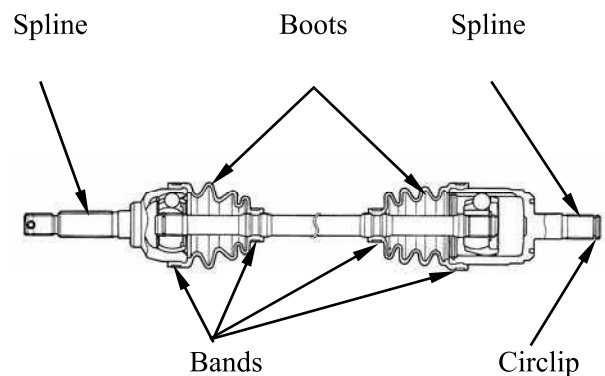

Inspect the free play by using a push-and-pull motion (thrust movement). Excessive play → Replace the joint assembly.

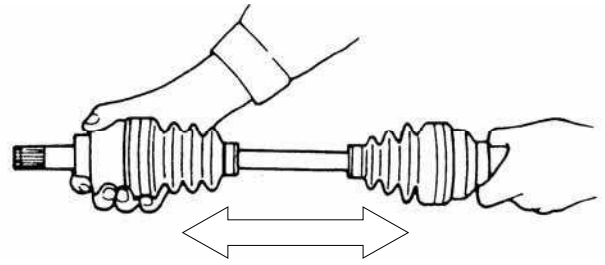

INSTALLATION

Install a new circlip into its groove in the splines.

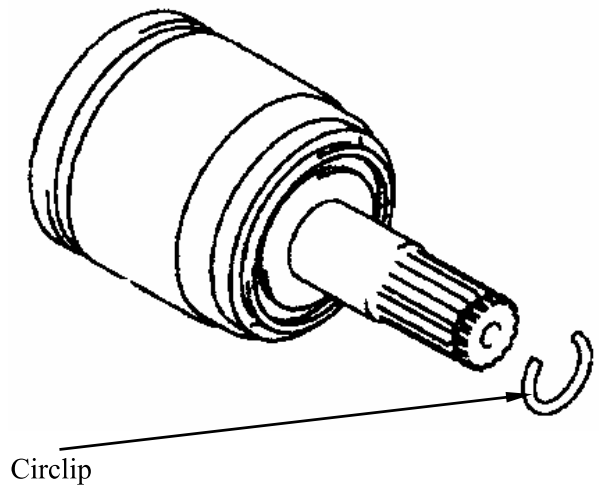

Apply lightweight lithium-soap base grease to the splines of the drive shafts and install the cvj to the front assy gear case.

- Be careful not to damage the oil seal in the front assy gear case.
- After installing cvj, check the circlip is seated properly by pulling the case side joint lightly.



Case Side Joint

13. DRIVE TRAIN

FRONT DRIVE SHAFT DISASSEMBLY/INSPECTION/ ASSEMBLY

DISASSEMBLY

Remove the front drive shaft (refer to the “**FRONT DRIVE SHAFT REMOVAL/INSPECTION/INSTALLATION**” section in this chapter)

Remove the boot band of the case side joint.

Slide the boot toward the center of the front cvj assy and remove the circlip from the case side joint.

Separate the case side joint from the front cvj assy

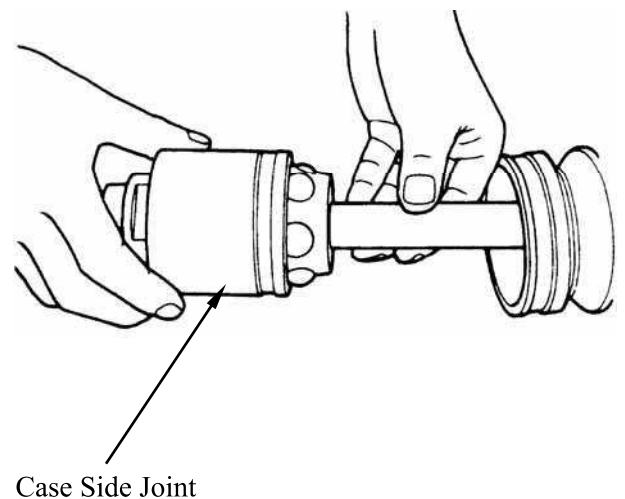
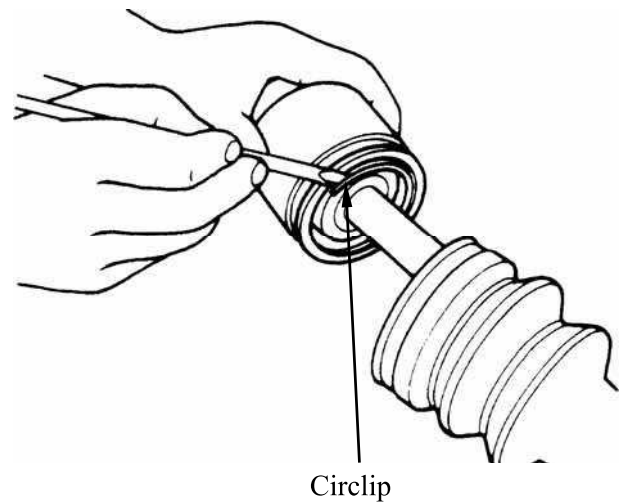
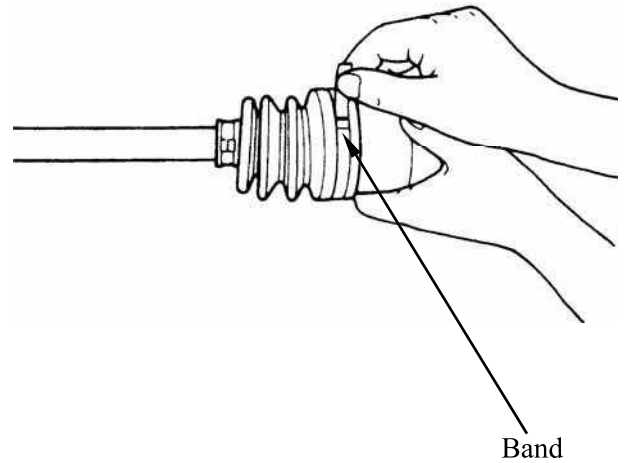

13. DRIVE TRAIN

Wipe off any grease and remove the snap ring from the groove on the front drive shaft.

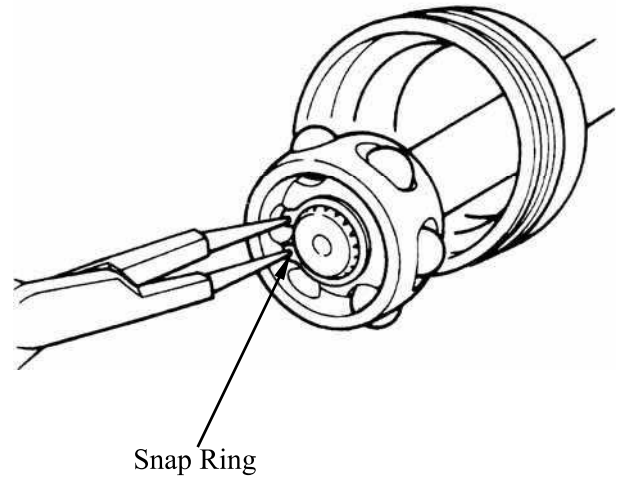

Remove the cage and boot from the front drive shaft.

Do not disassemble the wheel side joint. If any damages are found, replace the wheel side joint with a new one.

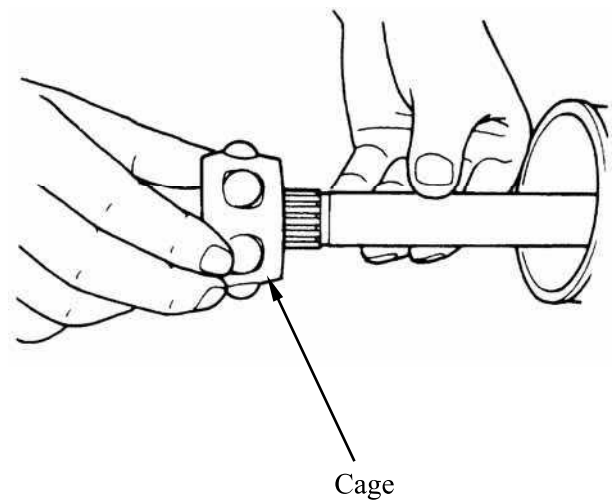

INSPECTION

Inspect the circlip and snap ring for wear or damage.

If any damages are found, replace them with new ones.

Inspect the cage and inner surface of case side joint for pitting, wear or damage.

If any damages are found, replace them with new ones.

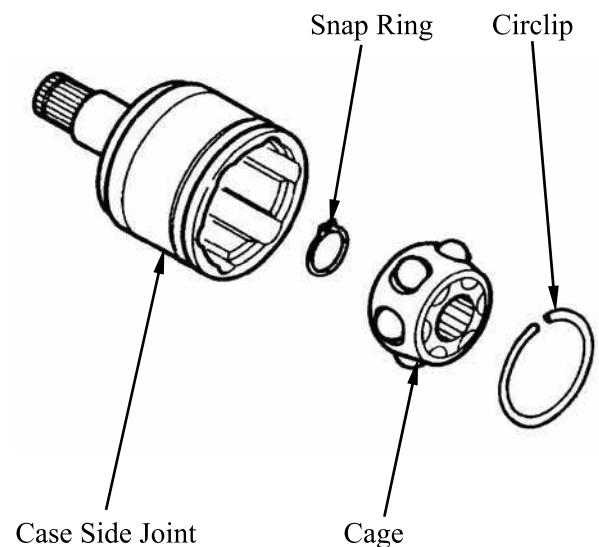

13. DRIVE TRAIN

Inspect the front drive shaft spline for wear or damage.

If any damages are found, replace them with a new one.

Inspect the front drive shaft for bends.

If any damages are found, replace them with a new one.

Do not attempt to straighten a bent shaft; this may dangerously weaken the shaft.

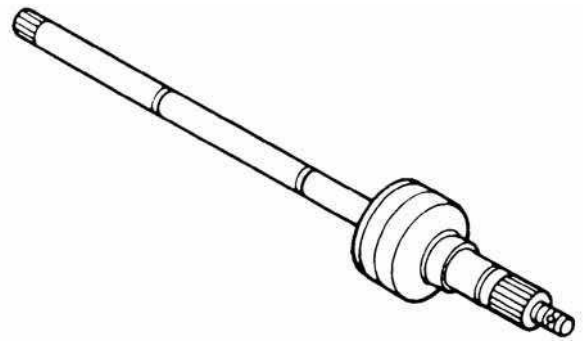

ASSEMBLY

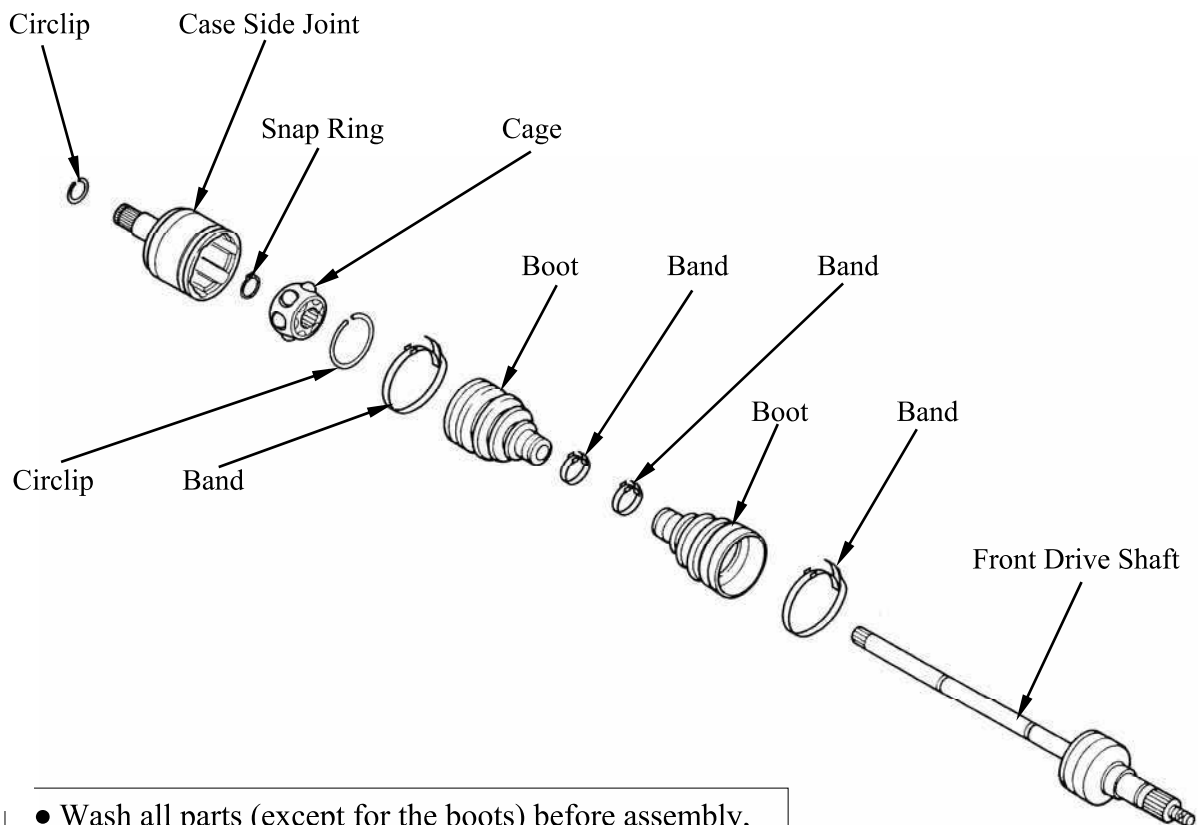

- Wash all parts (except for the boots) before assembly, clean the inside and outside of the boot with a cloth.
- Do not wash the boots in any commercially available degreaser, such as gasoline or kerosene. Washing in a degreaser causes deterioration of the boot.

13. DRIVE TRAIN

Fit a boot on the drive shaft end, fitting the small diameter side of the boot to the shaft groove, fix its end with a new band.

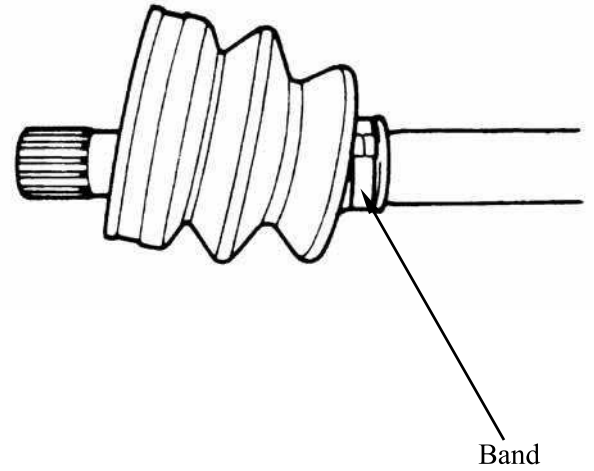

Install the cage on the shaft.

Install the cage with the large diameter side facing the shaft end.

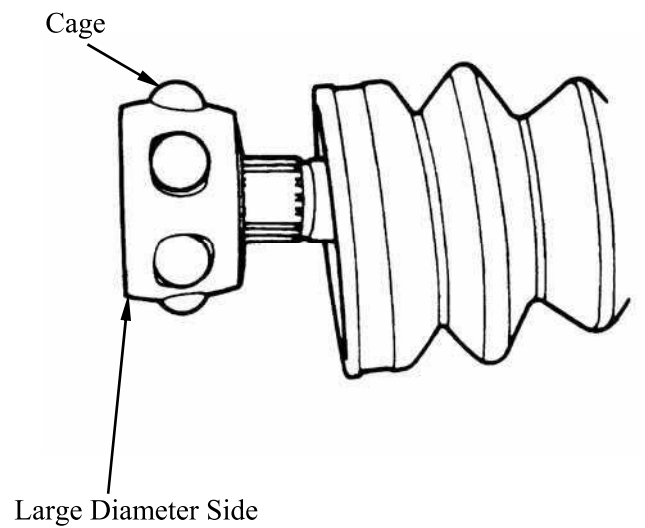

Install the snap ring to the groove on the drive shaft.

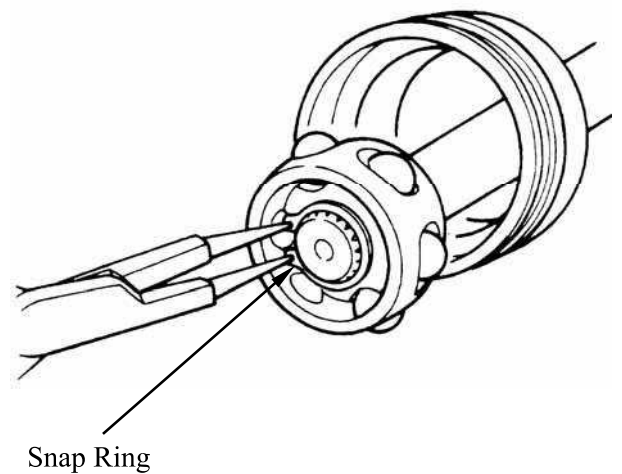

13. DRIVE TRAIN

Apply molybdenum disulfide grease to the entire surface of the cage and the inside of the case side joint/wheel side joint.

| Position Grease | Case side joint | Wheel side joint |
|--------------------|-----------------|------------------|
| Quantity | 85 g (2.8 oz) | 45 g (1.5 oz) |

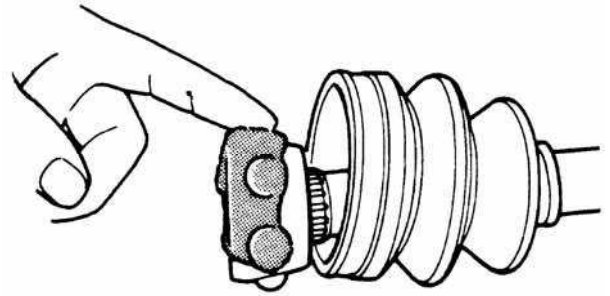

The tube of joint molybdenum disulfide grease is included in the wheel side boot set or wheel side joint assembly of spare parts.

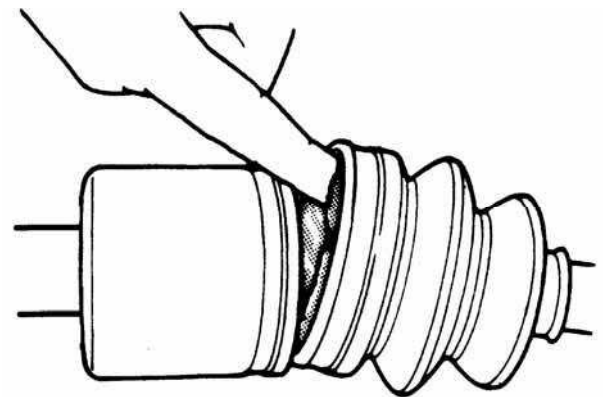

Insert the cage into the case side joint and fit a circlip in the groove of the case side joint.

Locate the opening of the circlip so that the opening is not lined up with a ball.

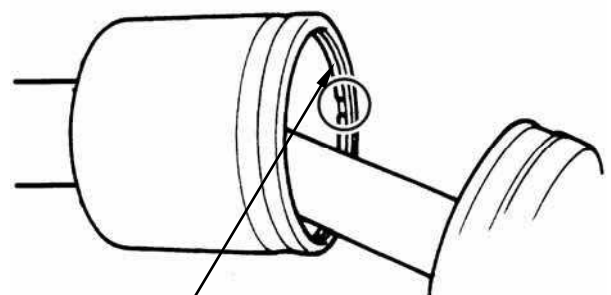

Circlip

13. DRIVE TRAIN

After fitting the boot on the case side joint, insert a screw driver into the boot on the case side joint and allow air to enter the boot so that the air pressure in the boot becomes the same as the atmospheric pressure.

Fix the boot on the case side joint with a new boot band, taking care not to distort the boot.

The dust boots should be fastened with the boot bands at the grooves in the drive shaft.

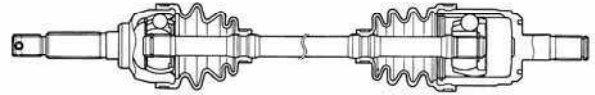

13. DRIVE TRAIN

FRONT ASSY GEARCASE REMOVAL/INSPECTION/ INSTALLATION

REMOVAL

Drain the front assy gear case oil (refer to the “**FRONT DRIVE GEAR OIL**” in the chapter 3).

Remove the steering knuckle (refer to the “**STEERING KNUCKLE REMOVAL/INSPECTION/INSTALLATION**” section in the chapter 14).

Remove the front upper arms and front lower arms (refer to the “**FRONT ARMS INSPECTION/REMOVAL/INSTALLATION**” section in the chapter 14).

Remove the drive shafts (refer to the “**FRONT DRIVE SHAFT REOMVAL/INSPECTION/INSTALLATION**” section in this chapter).

Disconnect the following wire connectors



13. DRIVE TRAIN

Remove the shaft input from front propeller shaft.

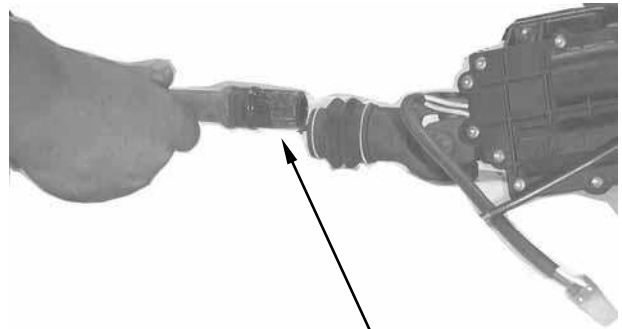

Front Propeller Shaft

Remove 2 front gear case mounting bolts/nuts from frame, then remove the case out of the frame.

INSPECTION

Check the breather rubber case for wear or damage. Also, check that the joint of the rubber case fits tightly.



13. DRIVE TRAIN

INSTALLATION

Install the front drive case into the frame.

Install and tighten the two mounting bolts/nuts to the specified torque.

Torque: 4 kgf-m (40 N-m, 29 lbf-ft)

Install the front propeller shaft.

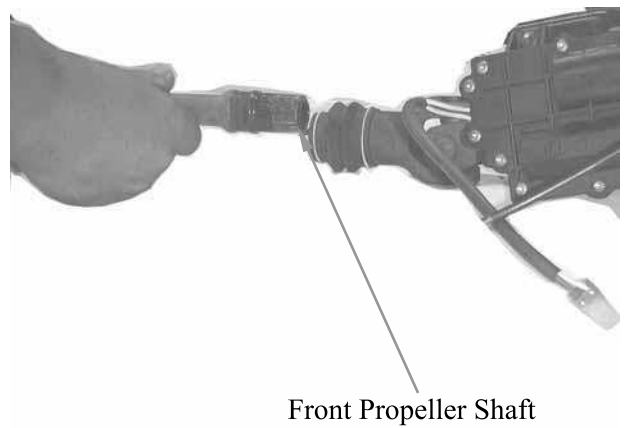

Connect all wire connectors and then install.



13. DRIVE TRAIN

FRONT ASSY GEAR CASE DISASSEMBLY/INSPECTION/ ASSEMBLY

Remove the front drive case assembly (refer to the “**FRONT DRIVE REMOVAL/INSPECTION/INSTALLATION**” section in this chapter).

Remove the 3 bolts and then remove the 2WD/4WD shifting motor assembly.

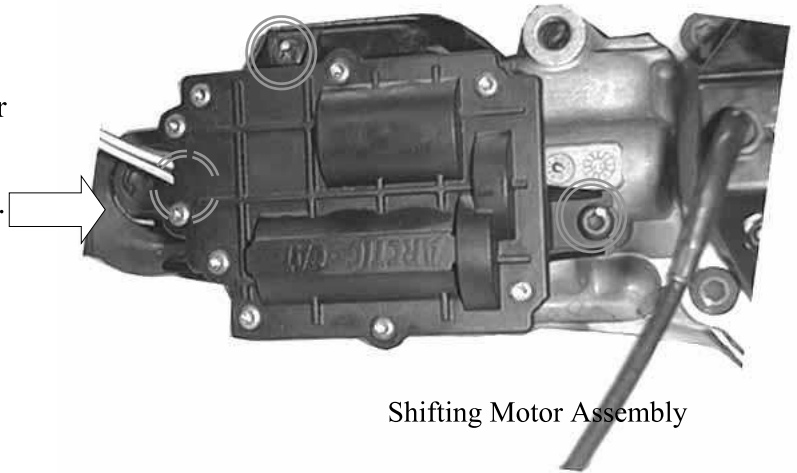

Shifting Motor Assembly

Remove the differential lock lever wire.
From front gear case.

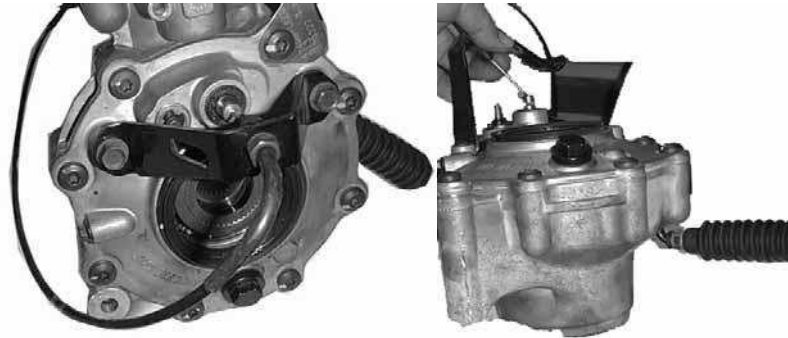

Remove the 3 bolts from housing pinion
Disconnect the housing pinion



13. DRIVE TRAIN

Remove the clip from shaft input
Disconnect the shaft input

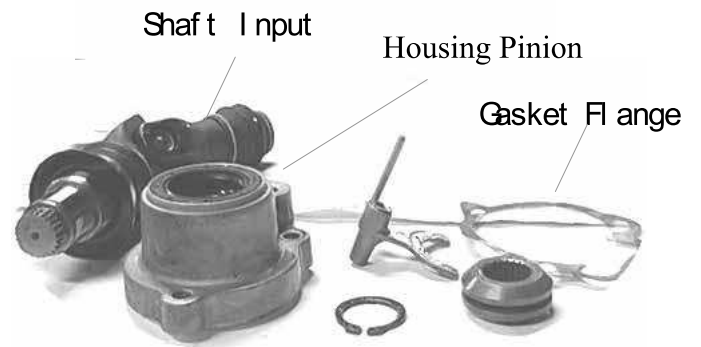
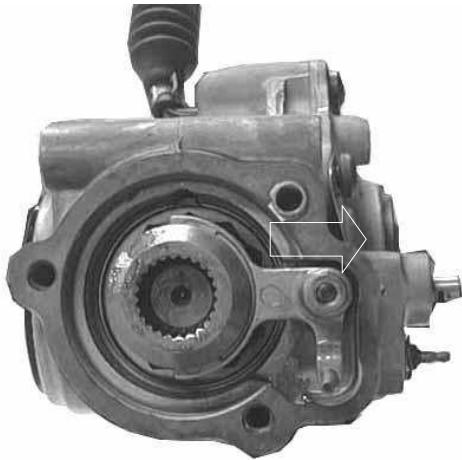

Remove the 8 bolts from the front assy
Gear case .
Disconnect the cover machined



13. DRIVE TRAIN

Remove front gear ring from gear case

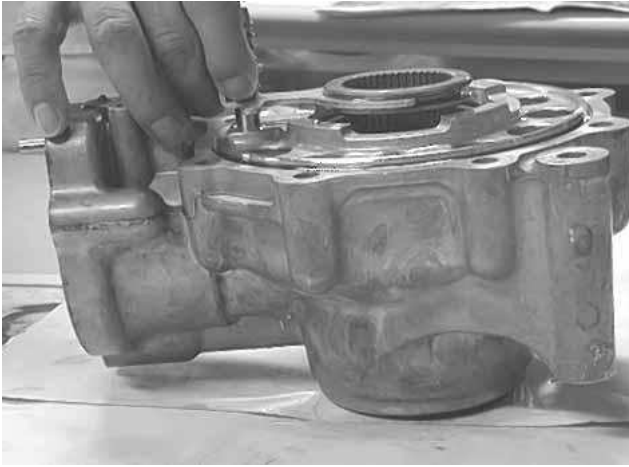

Using the 48mm internal Hex Socket
Into the housing gear case
Disconnect the front gear ring

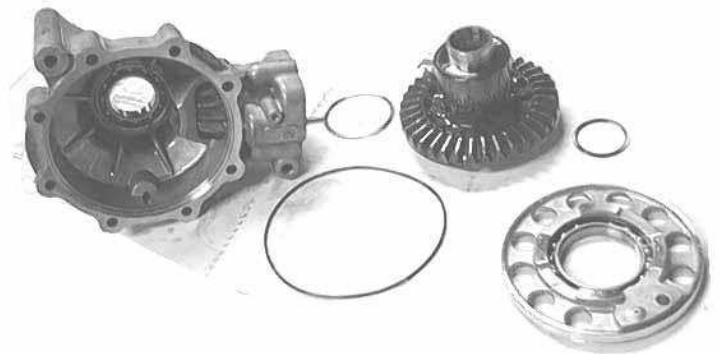

13. DRIVE TRAIN

Using the **SPECIAL TOOL:A120F00025**
And hammer./screwdriver Remove the
pinion gear from the gear case housing.

Tighten to 125 ft-lb



SPECIAL TOOL:A120F00025

SPECIAL TOOL:A120F00025

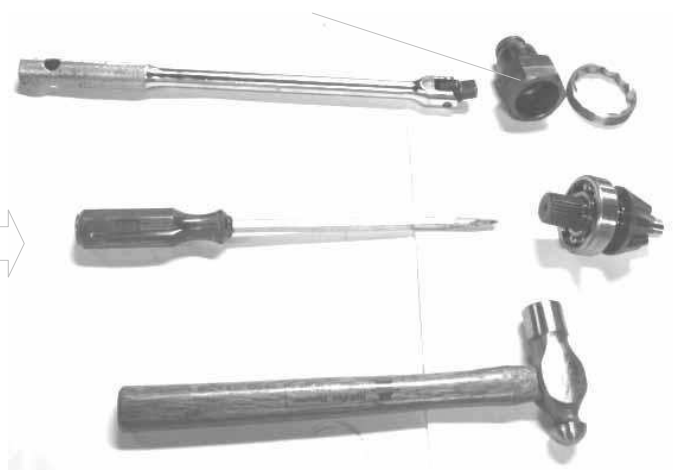
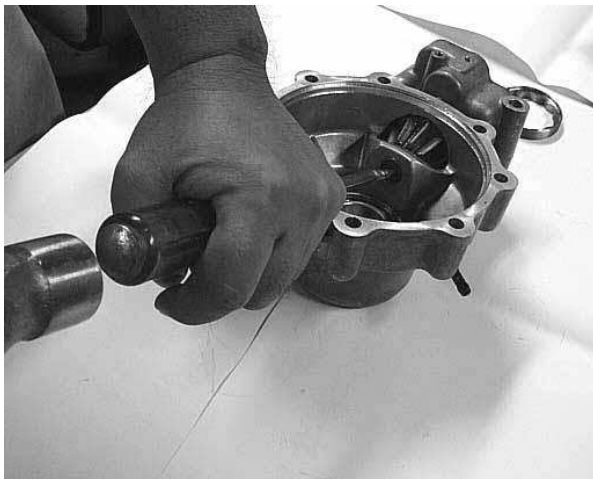

Secure the pinion gear in a bearing puller.
Then remove the pinion bearing using a
press. Account for a collar and a bearing.



13. DRIVE TRAIN

Remove Needle Bearing

Using the hammer./screwdriver Remove the Needle bearing.

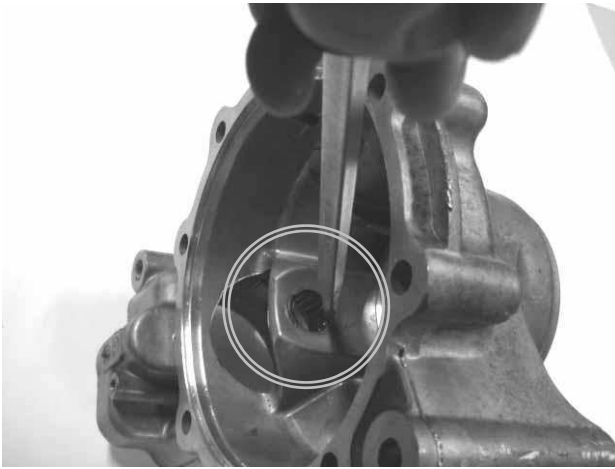

Remove and Installing Axle Bearing

Using a hammer./tool Remove the bearing.



Using a hammer./tool installing new bearing. Into the housing.

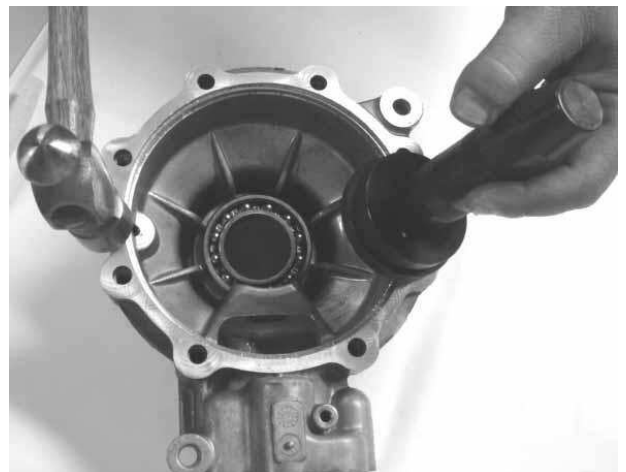

13. DRIVE TRAIN

REAR ASSY GEAR CASE REMOVAL/INSPECTION/ INSTALLATION

REMOVAL

Remove the left rear axle housing (refer to the “**REAR AXLE HOUSING REMOVAL/INSPECTION/INSTALLATION**” section in the chapter 15).

Remove the cvj assy right rear using Suitable tools.

Using hammer remove the cvj assy l e f t r e a r



13. DRIVE TRAIN

Remove 2 rear gear case mounting bolts/nuts from frame, then remove the case out of the frame.

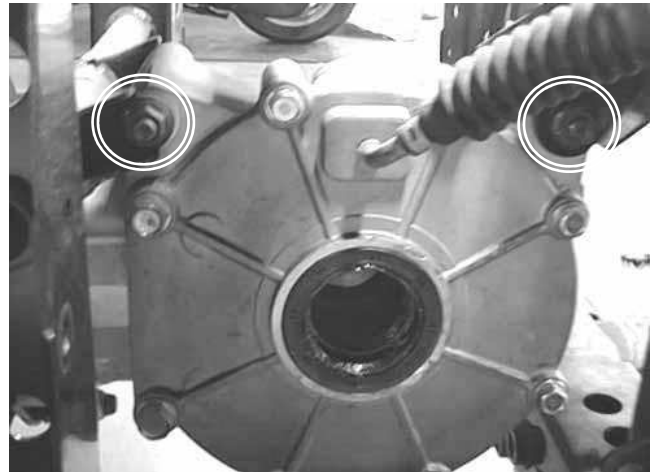

Remove 1 bolt from holder disc rear brake, then remove the holder disc rear brake

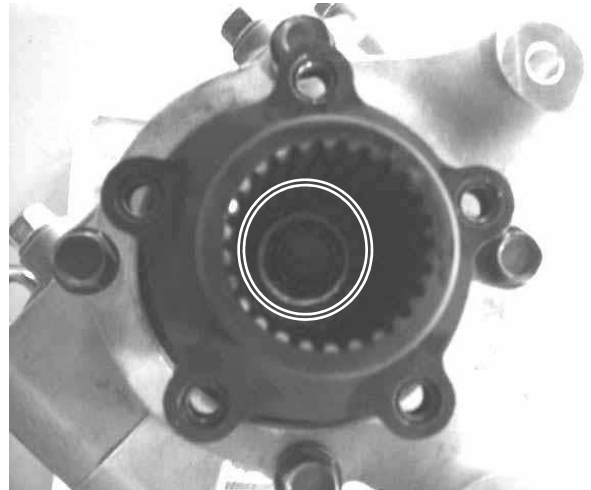

Remove 4 bolts from bracket caliper, then remove the bracket caliper

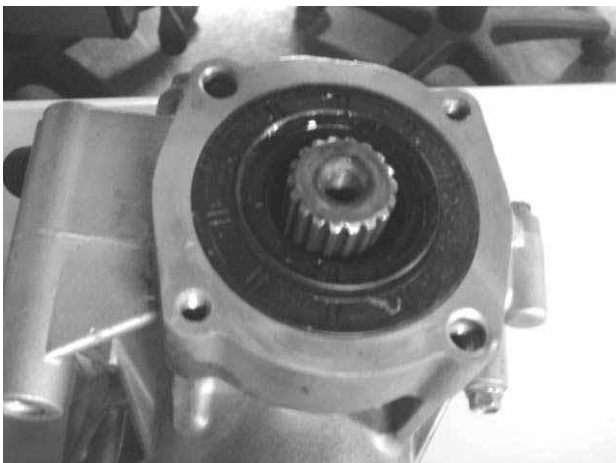

13. DRIVE TRAIN

Remove 7 bolts from R side case rear final, then remove R side case rear final



L side case rear

Gear Ring

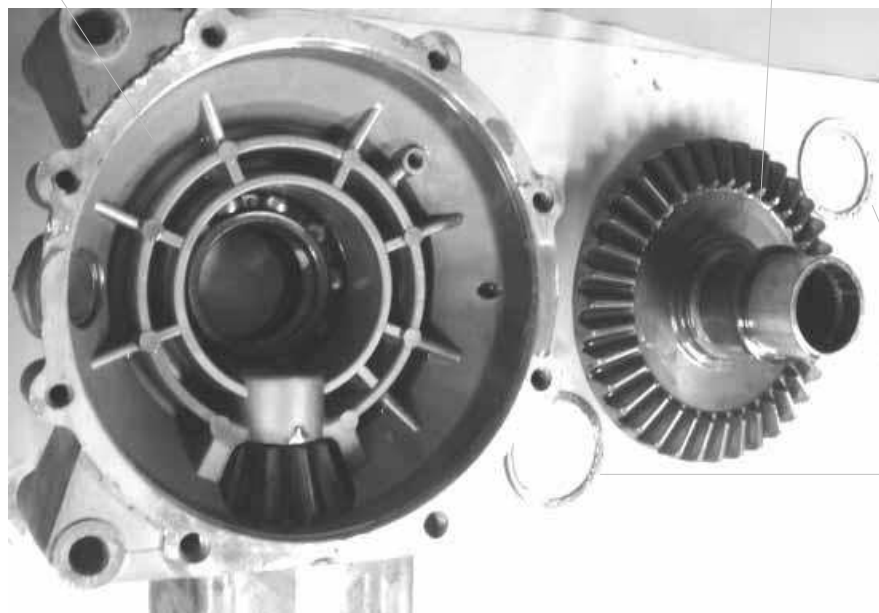

Shim Ring
Gear

13. DRIVE TRAIN

Remove the bearing lock nut by using special tool.

Special tool:

Bearing lock nut wrench A120F00020



Using the **SPECIAL TOOL:A120F00026**

Remove the pinion gear from the gear case housing.

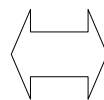
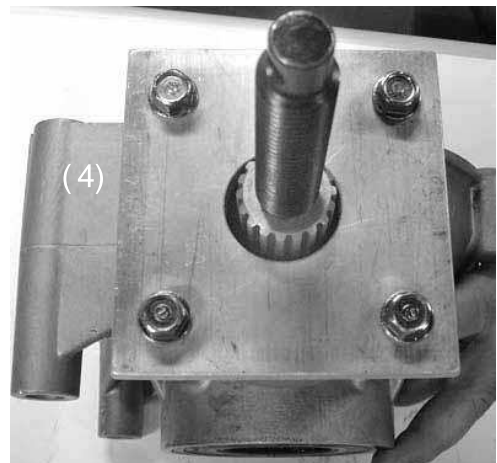
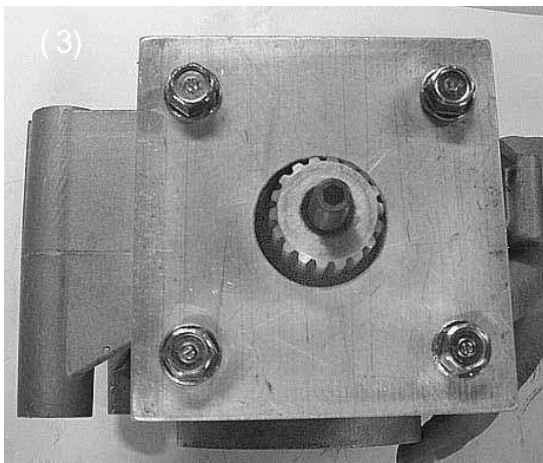
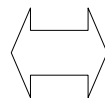
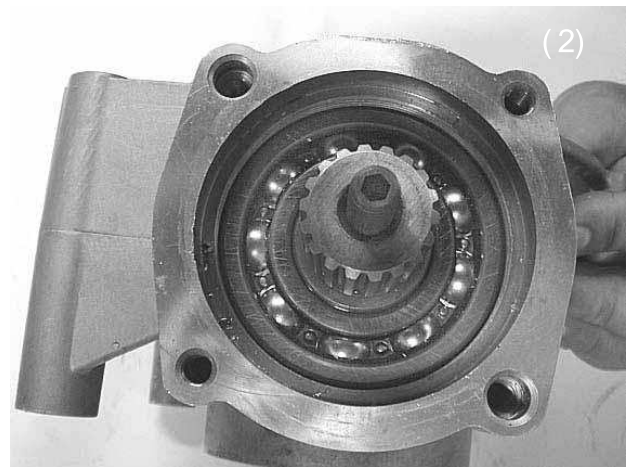
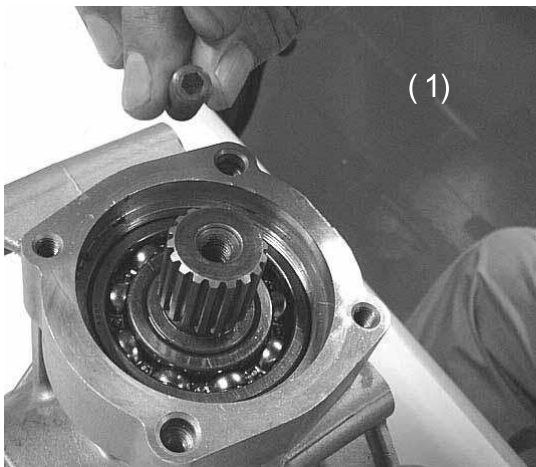

13. DRIVE TRAIN

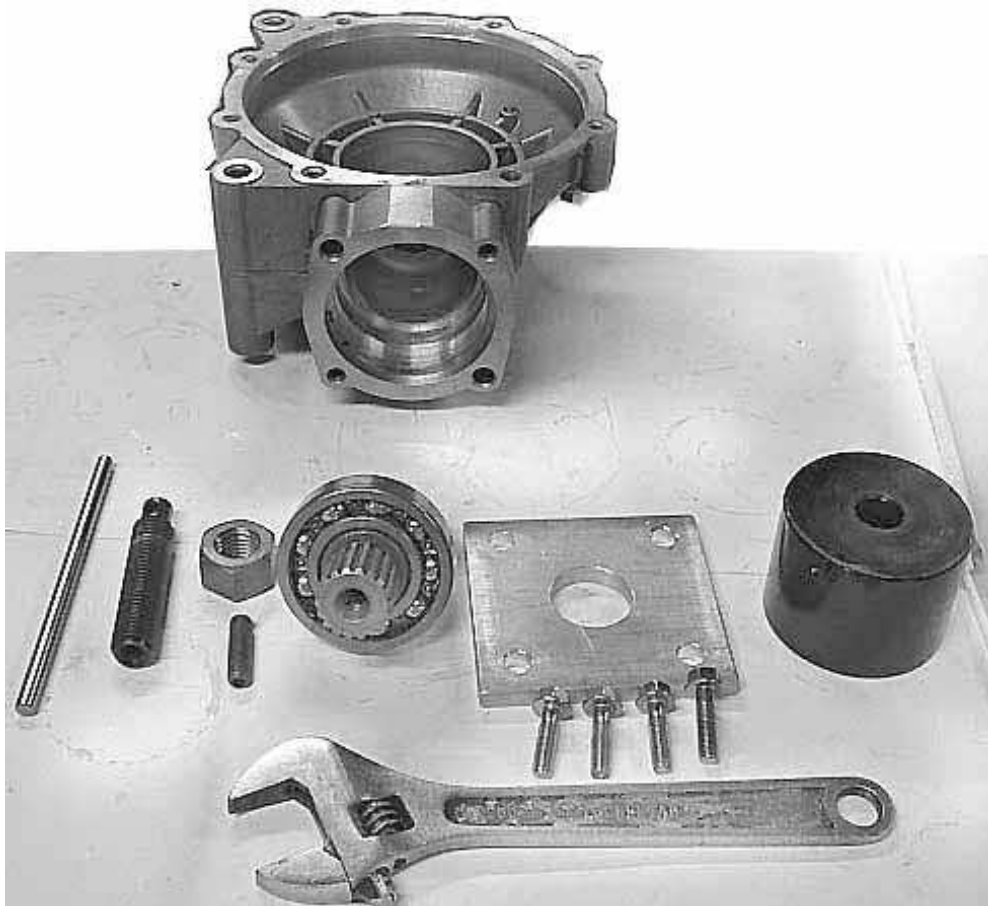
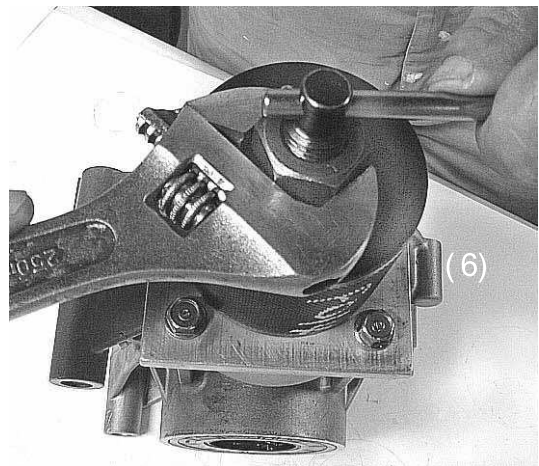
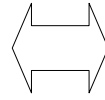
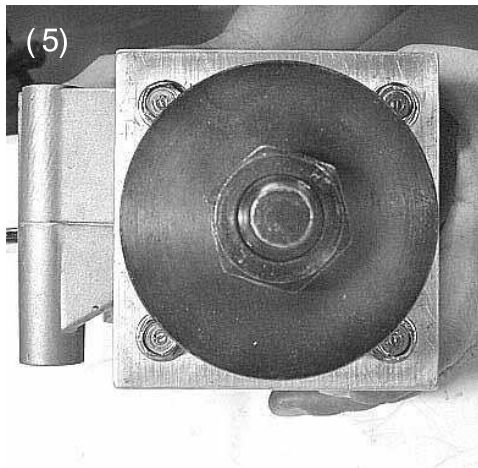

SPECIAL TOOL:A120F00026

13. DRIVE TRAIN

Secure the pinion gear in a bearing puller.
Then remove the pinion bearing using a press. Account for a collar and a bearing.

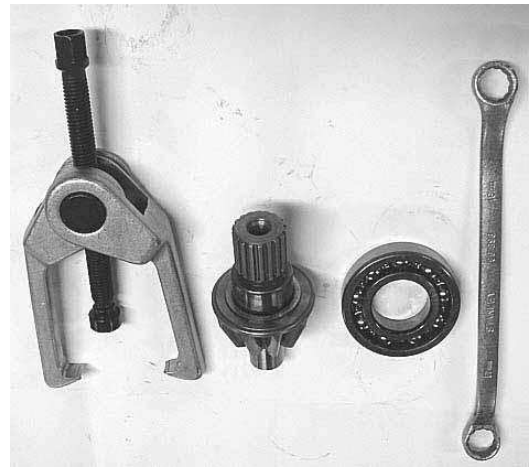
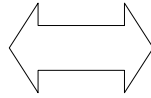
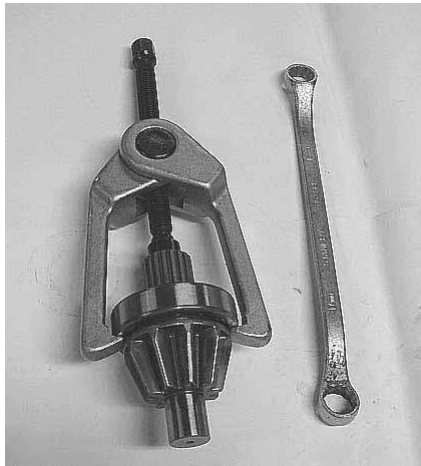

Remove the needle bearing.
by using the special tools.

Special tool:

Bearing puller A120E00037

Needle Bearing

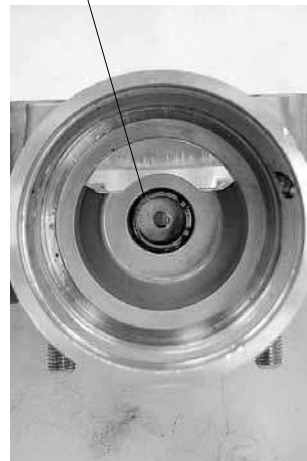

**FRONT WHEEL/FRONT SUSPENSION STEERING
SYSTEM**

| | | |
|--|-----|----|
| SERVICE INFORMATION----- | 14- | 2 |
| TROUBLESHOOTING----- | 14- | 3 |
| FRONT WHEEL REMOVAL/INSPECTION/INSTALLATION ---- | 14- | 4 |
| FRONT WHEEL HUB REMOVAL/INSPECTION/ INSTALLATION ----- | 14- | 5 |
| FRONT SHOCK ABSORBER REMOVAL/INSPECTION/ INSTALLATION ----- | 14- | 7 |
| STEERING KNUCKLE REMOVAL/INSPECTION/ INSTALLATION ----- | 14- | 8 |
| HANDLEBAR REMOVAL/INSPECTION/INSTALLATION ----- | 14- | 15 |
| STEERING COLUMN REMOVAL/INSPECTION/INSTALLATION ----- | 14- | 19 |

14. FRONT WHEEL/FRONT SUSPENSION STEERING SYSTEM

KYMCO
MXU 500 IRS

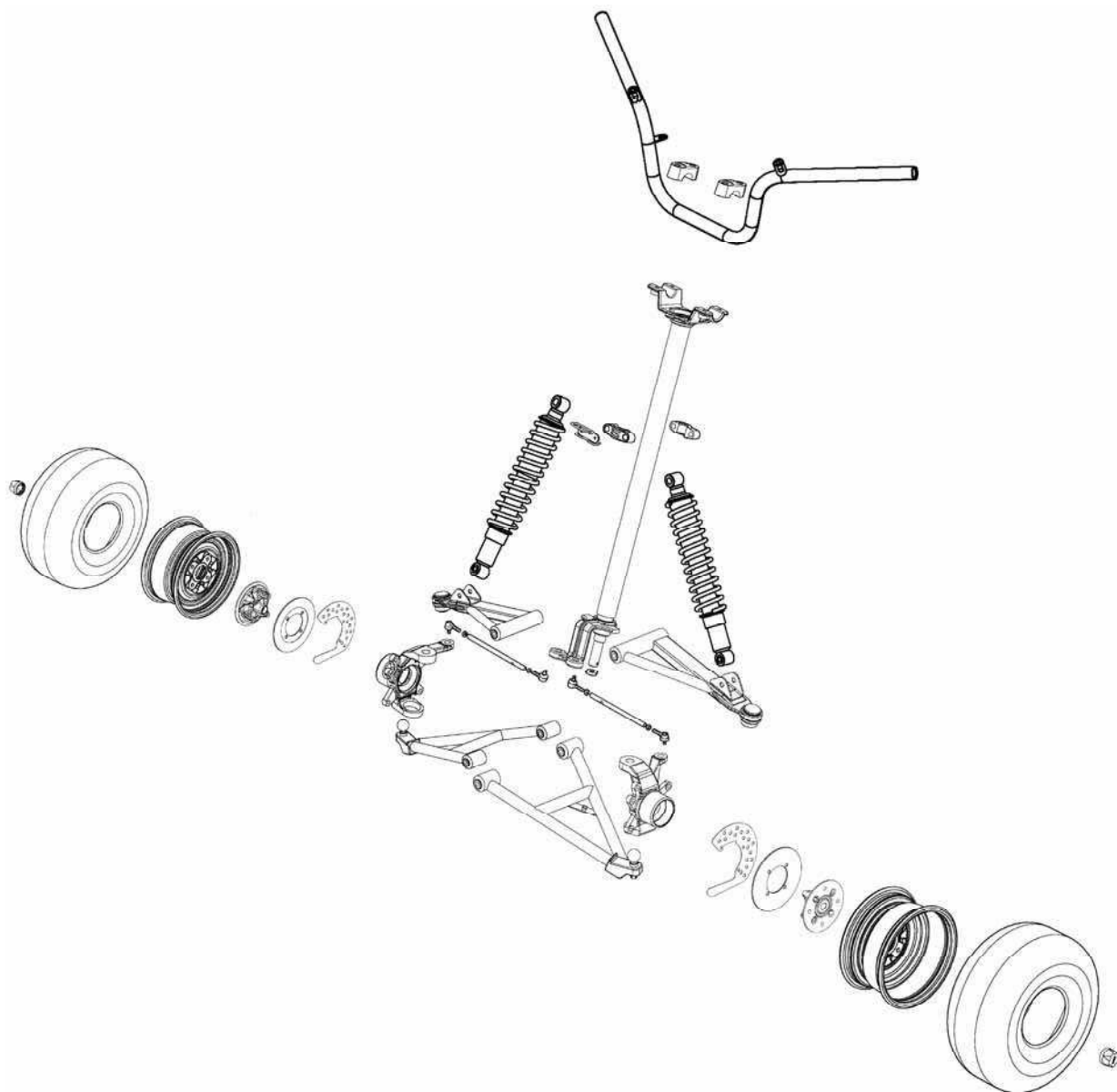

14. FRONT WHEEL/FRONT SUSPENSION/ STEERING SYSTEM



SERVICE INFORMATION

GENERAL INSTRUCTIONS

- Jack the machine front wheel off the ground and be careful to prevent the machine from falling down.
- During servicing, keep oil or grease off the brake disk
- Inspect the brake system before riding.

SPECIFICATIONS

Unit: mm (in)

| Item | | Standard | Service Limit |
|-------------------------|--------|--------------------------|---------------|
| Front wheel rim run out | Radial | — | 2 (0.08) |
| | Axial | — | 2 (0.08) |
| Tie rod length | | 379.75±0.25 (15.19±0.01) | — |
| Rod-end (tie rod) angle | | 180° | — |

TORQUE VALUES

| | |
|---------------------------------|--|
| Steering column nut | 7 kgf-m (70 N-m, 50 lbf-ft) |
| Front swing arm nut | 4.8 kgf-m (48 N-m, 35 lbf-ft) |
| Front wheel nut | 5.5 kgf-m (55 N-m, 40lbf-ft) |
| Front wheel hub nut | 20 kgf-m (200 N-m, 145 lbf-ft) Castle nut |
| Tie-rod ball joint nut | 3.5 kgf-m (35 N-m, 25.5 lbf-ft) Castle nut |
| Tie-rod adjusting nut | 4.0 kgf-m (40 N-m, 29 lbf-ft) |
| Front shock absorber mount bolt | 4.5 kgf-m (45 N-m, 32 lbf-ft) |
| Handlebar holder bolt | 2.5 kgf-m (25 N-m, 18 lbf-ft) |
| Steering bracket | 2.2 kgf-m (22 N-m, 16 lbf-ft) |

SPECIAL TOOLS

| | |
|-----------------------------|------------|
| Oil seal and bearing driver | A120E00014 |
|-----------------------------|------------|

14. FRONT WHEEL/FRONT SUSPENSION STEERING SYSTEM



TROUBLESHOOTING

Hard steering (heavy)

- Insufficient tire pressure

Steers to one side or does not track straight

- Uneven front shock absorbers
- Bent front arm
- Bent steering knuckle

Front shock absorber noise

- Slider bending
- Loose arm fasteners
- Lack of lubrication

Front wheel wobbling

- Bent rim
- Excessive wheel bearing play
- Bent spoke plate
- Faulty tire
- Improperly tightened axle nut

Soft front shock absorber

- Weak shock springs
- Insufficient damper oil

14. FRONT WHEEL/FRONT SUSPENSION/ STEERING SYSTEM

FRONT WHEEL REMOVAL/INSPECTION/ INSTALLATION

REMOVAL

Place the machine on a level place.
Remove four nuts from front wheel.

Elevate the front wheels by placing a suitable stand under the frame.

Support the machine securely so there is no danger of it falling over.

Remove the wheel and wheel hub nut cap together.



Wheel Hub Nut Cap

INSPECTION

Measure the wheel run out.
Replace wheel or check bearing play if out of specification

Rim run out limits:

Vertical: 2 mm (0.08 in)

Lateral: 2 mm (0.08 in)

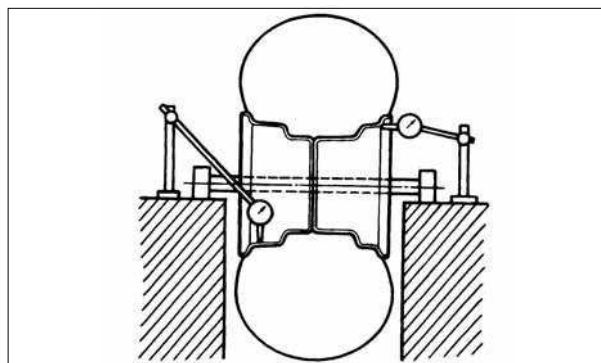

INSTALLATION

When reinstalling a wheel, tighten the wheel nuts in a crisscross (rather than a circular) pattern.

Torque: 5.5 kgf-m (55 N-m)

Be sure the tapered side of the wheel nuts face the wheel rim.

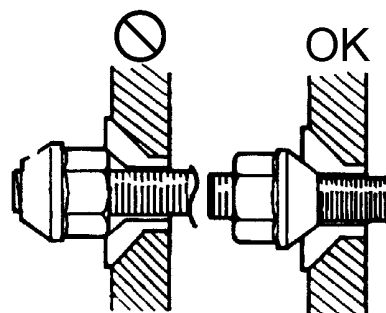

14. FRONT WHEEL/FRONT SUSPENSION STEERING SYSTEM

FRONT WHEEL HUB REMOVAL/INSPECTION/ INSTALLATION

REMOVAL

Place the machine on a level place.
Remove the front wheel (refer to the
“FRONT WHEEL
REMOVAL/INSPECTION/
INSTALLATION” section in this chapter)
Elevate the front wheels by placing a
suitable stand under the frame.

**Support the machine securely so there
is no danger of it falling over.**

Remove the cotter pin.

Apply the front brake and then remove nut,
washer and front wheel hub.

INSPECTION

Check the wheel hub for cracks or deamage.
Check the wheel hub splines for wear or
damage.

Nut/Washer

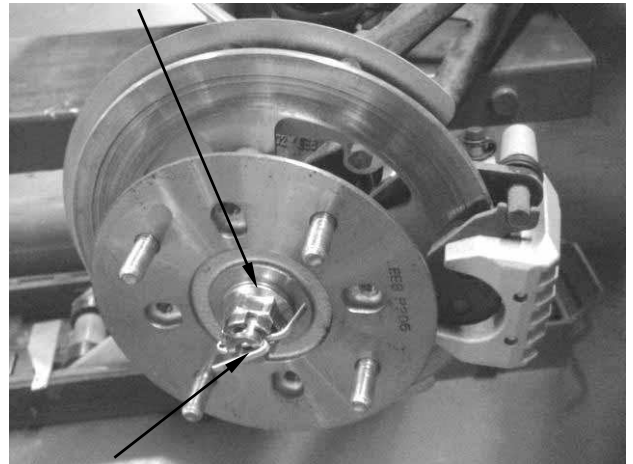

Cotter Pin

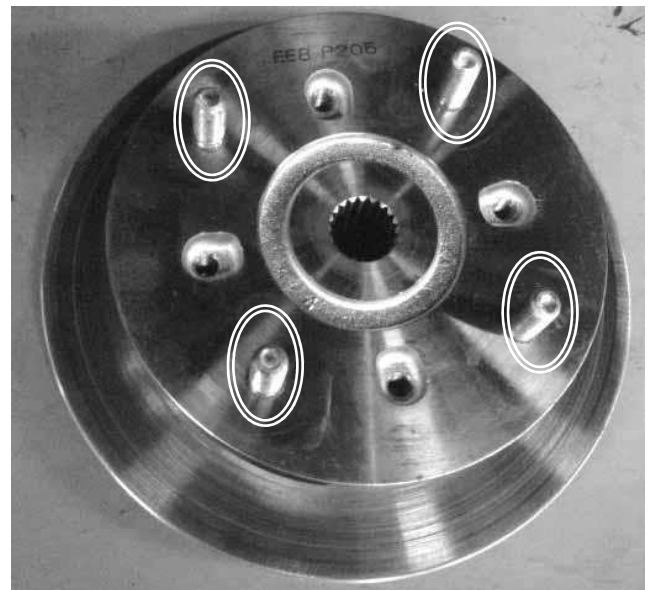

14. FRONT WHEEL/FRONT SUSPENSION/ STEERING SYSTEM

INSTALLATION

Install the wheel hub, washer and nut.

Apply grease onto the wheel hub splines.

Apply the front brake and then tighten the nut to the specified torque.

Torque: 7 kgf-m (70 N-m, 50 lbf-ft)

Install the cotter pin and band ends of cotter pin.

Nut/Washer

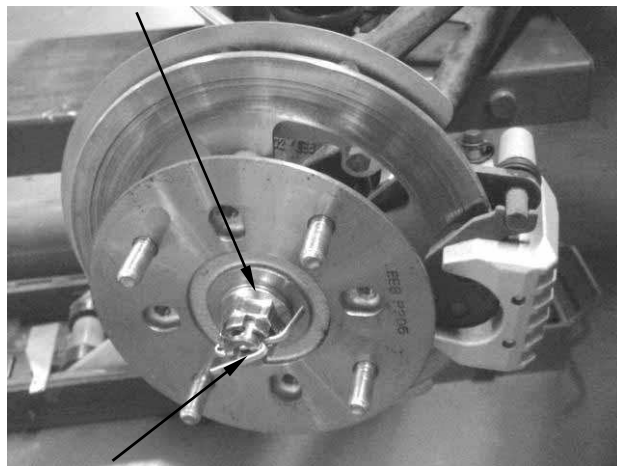

Cotter Pin

- Do not apply oil to the seat of the nut.
- Do not loosen the wheel hub nut after torque tightening. If the wheel hub nut groove is not aligned with the cotter pin hole, align groove with the hole by tightening up on the wheel hub nut.

Always use a new cotter pin.

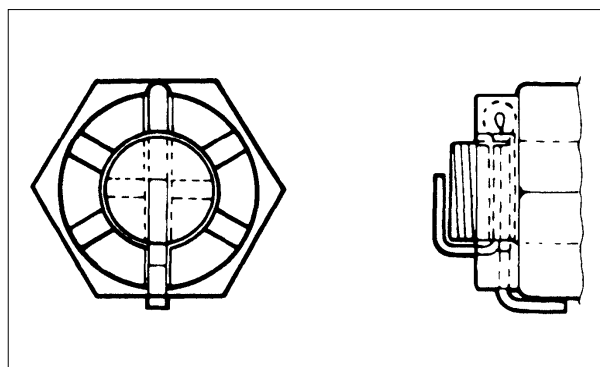

14. FRONT WHEEL/FRONT SUSPENSION STEERING SYSTEM

FRONT SHOCK ABSORBER REMOVAL/INSPECTION/ INSTALLATION

REMOVAL

Remove the front shock absorber upper mount and lower mount bolts/nuts, then remove the front shock absorber.

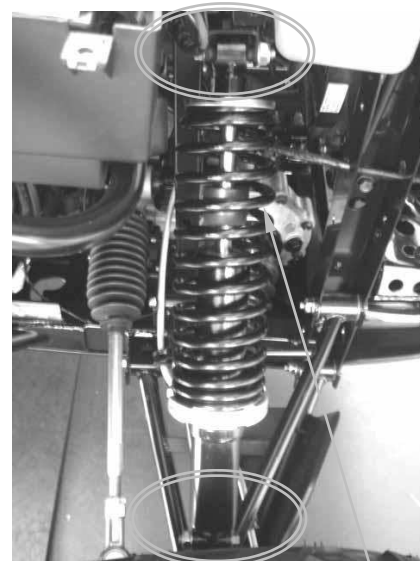

Shock Absorber

INSPECTION

Inspect the shock absorber rod.
Bends/damage → Replace the shock absorber assembly.
Inspect the shock absorber.
Oil leaks → Replace the shock absorber assembly.
Inspect the spring of the shock absorber by move the spring up and down.
Fatigue → Replace the shock absorber assembly.
Inspect bushes, collar and dust seals.
Wear/damage → Replace.

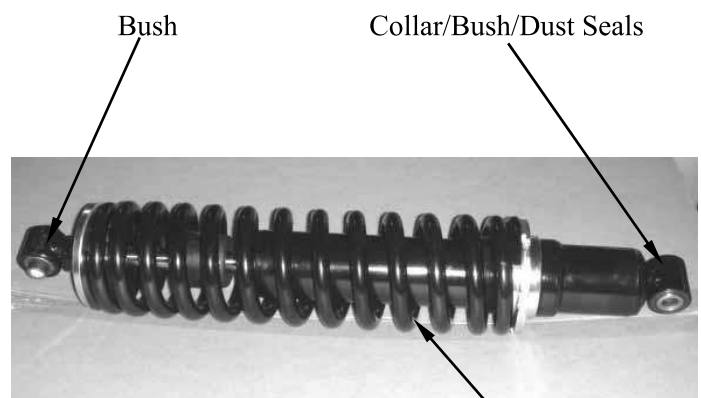

Shock Absorber

INSTALLATION

Apply the grease onto the bushes, then install the shock absorber and tighten the upper mount and lower mount bolts/nuts to the specified torque.

Torque: 4.5 kgf-m (45 N-m, 32 lbf-ft)

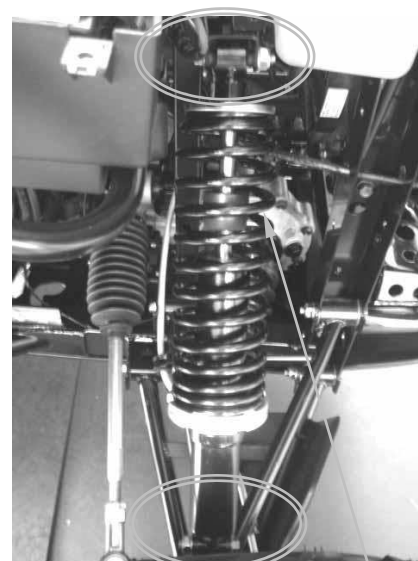

Shock Absorber

14. FRONT WHEEL/FRONT SUSPENSION/ STEERING SYSTEM

STEERING KNUCKLE REMOVAL/INSPECTION/ INSTALLATION

REMOVAL

Elevate the front wheels by placing a suitable stand under the frame.

Support the machine securely so there is no danger of it falling over.

Remove the front wheel hub

Remove the three bolts and brake disc protection plate.

Remove the cotter pin and nut from the tie-rod end.

Remove the 2 bolts

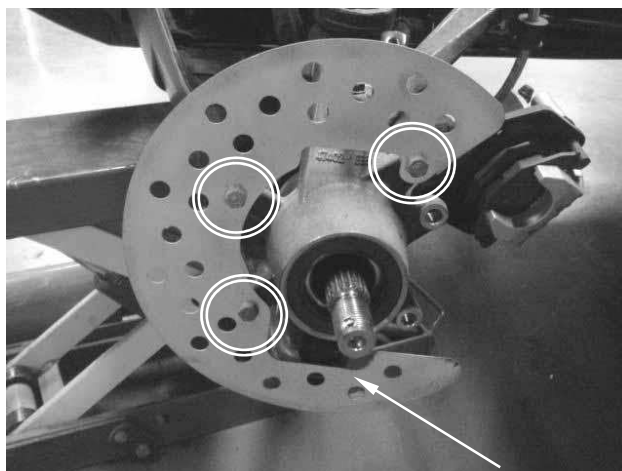

Plate

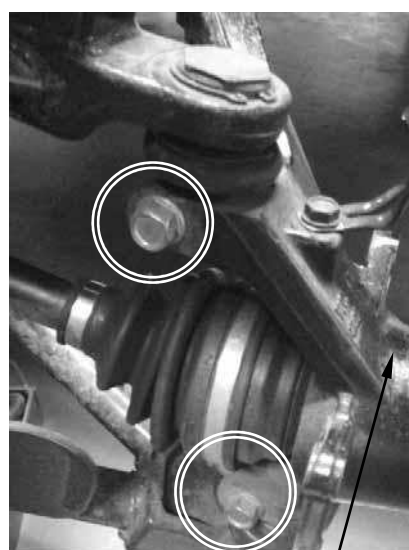

Steering Knuckle

14. FRONT WHEEL/FRONT SUSPENSION STEERING SYSTEM

Release the tie-rod ball joint/upper arm ball joint off the knuckle.

Apply grease to the ball joint remover at the point shown.

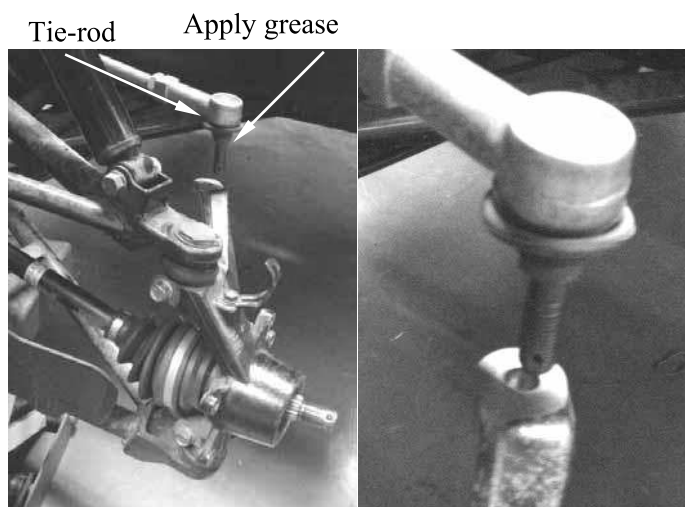

Remove the knuckle from the upper and lower arms



14. FRONT WHEEL/FRONT SUSPENSION/ STEERING SYSTEM



INSPECTION

Inspect the knuckle end boot for wear or damage.

If any damages are found, replace the knuckle end with a new one.

Inspect the dust seal lips for wear or damage.

If any damages are found, replace the dust seal with a new one.

Inspect the brake disc protection plate for damage.

If any damages are found, replace the brake disc protection plate with a new one.

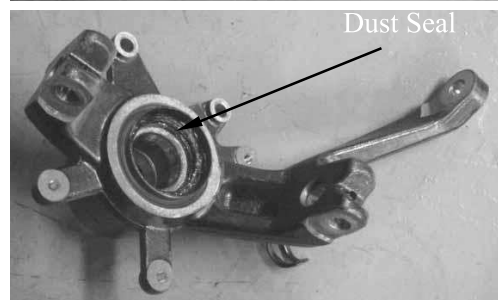
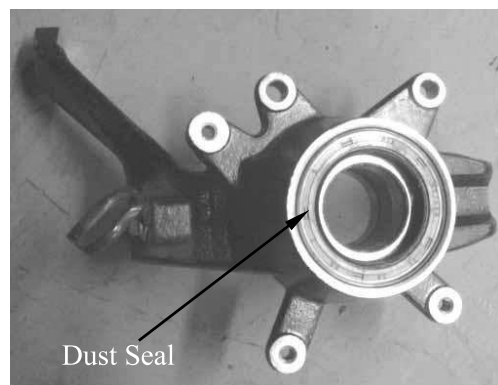

14. FRONT WHEEL/FRONT SUSPENSION STEERING SYSTEM

INSTALLATION

Apply lightweight lithium-soap base grease to the bearings of the steering knuckle and lips of the dust seal before install the steering knuckle.

Install the steering knuckle onto the upper and lower front arms and tighten the nuts to the specified torque.

Torque: 3.5 kgf-m (35 N-m, 25 lbf-ft)

Install the cotter pins and band ends of cotter pins.

Always use a new cotter pin.

Install the tie-rod onto the steering knuckle and tighten the nut to the specified torque.

Torque: 4.8kgf-m (48 N-m, 34 lbf-ft)

Install the lock 2 bolts

Always use a new cotter pin.

- Do not apply oil to the seat of the nuts.
- Do not loosen the nuts after torque tightening. If the nuts groove is not aligned with the cotter pins hole, align groove with the hole by tightening up on the nuts.

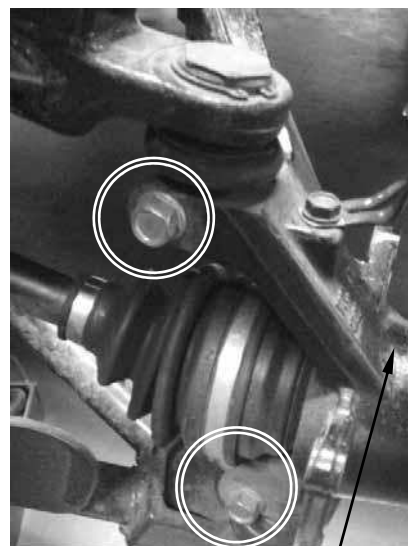

Steering Knuckle

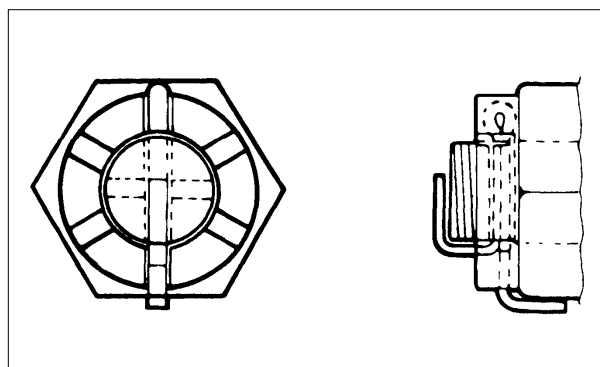

14. FRONT WHEEL/FRONT SUSPENSION/ STEERING SYSTEM

KYMCO
MXU 500IRS

Install the brake disc protection plate and then tighten the three bolts securely.

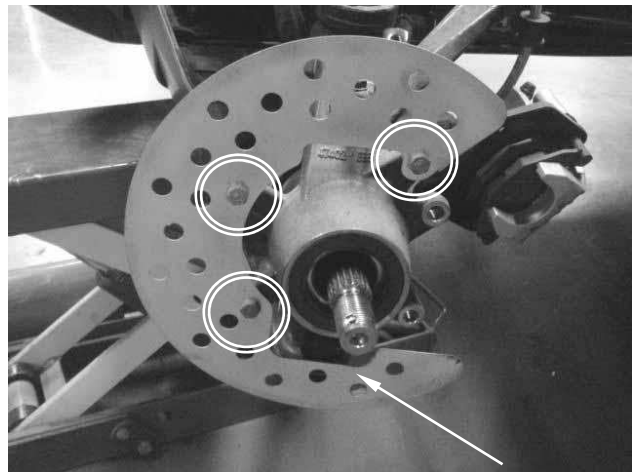

Plate

14. FRONT WHEEL/FRONT SUSPENSION STEERING SYSTEM

STEERING KNUCKLE DISASSEMBLY/ASSEMBLY

DISASSEMBLY

Remove the dust seals.

Inspect the inner race play of the bearing by hand while it is in the steering knuckle. Rotate the inner race by hand to inspect for abnormal noise and smooth rotation. If there is anything unusual, replace the bearing with a new one.

Make sure to check bearing in the same manner.

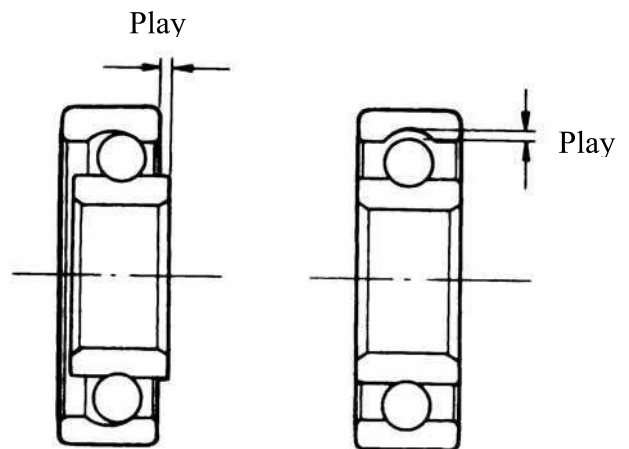
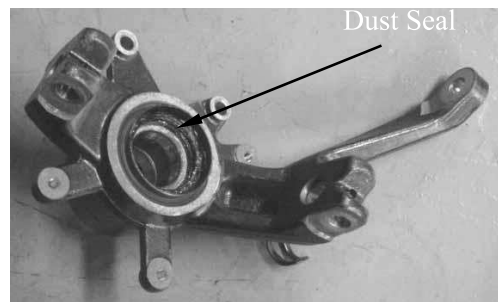
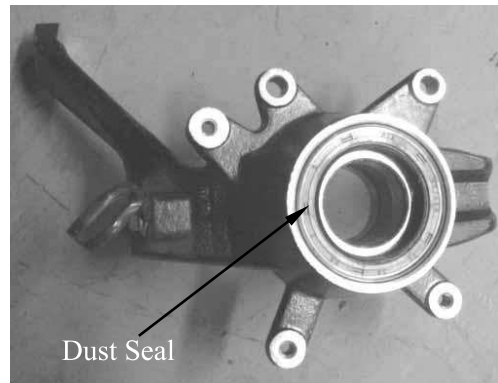

Remove the bearings using the appropriate bar, then remove the spacer.



14. FRONT WHEEL/FRONT SUSPENSION/ STEERING SYSTEM

ASSEMBLY

Apply lightweight lithium-soap base grease to the new bearings of the steering knuckle and lips of the new dust seal before install them.



Install the new inner bearing by using the special tool.

Special tool:
Oil seal and bearing driver A120E00014

Install the spacer into the steering knuckle.

Make sure the long side of the spacer faces the outer bearing



Bearing Driver

Install the new outer bearing by using the special tool.

Special tool:
Oil seal and bearing driver A120E00014



Bearing Driver

Install the new dust seals by using the special tool.

Special tool:
Oil seal and bearing driver A120E00014



14. FRONT WHEEL/FRONT SUSPENSION STEERING SYSTEM

HANDLEBAR REMOVAL/INSPECTION/ INSTALLATION

REMOVAL

Remove the frame cover (refer to the “FRAME COVERS” section in the chapter 2).

Remove the two bolts and then remove left master cylinder from the handlebar. Remove the band and then remove the brake light switch wire from the handlebar.

Remove the two screws and then remove the left handlebar switch from the handlebar.

Remove the two screws and then remove the throttle lever assembly.

Remove the nut then remove the choke knob from the handlebar.

Remove the band and then remove the brake light wire and 2WD/4WD select switch wire from the handlebar.

Remove the two bolts and then remove the master right cylinder from the handlebar.

Master Cylinder

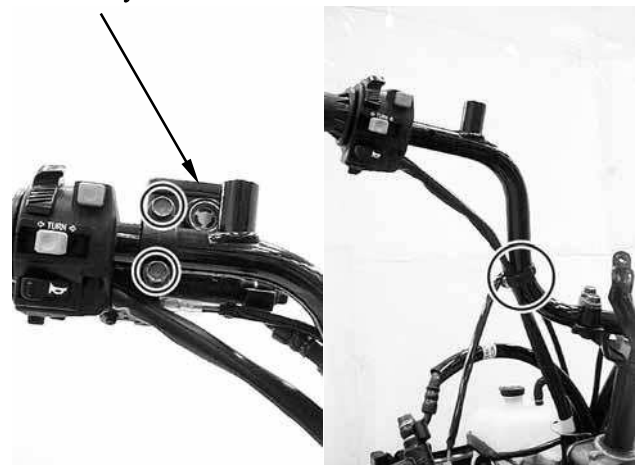

Throttle Lever Assembly

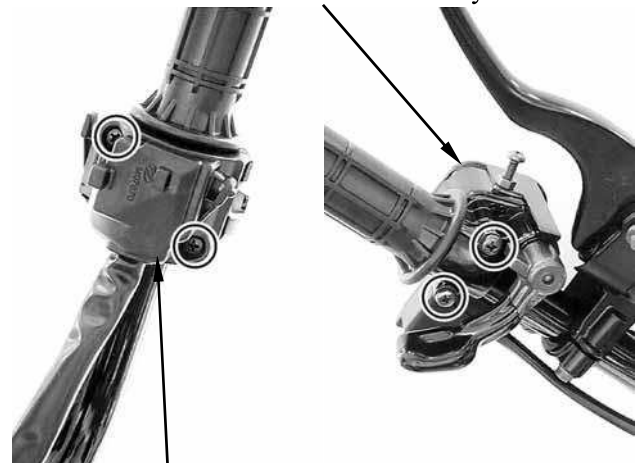

Left Handlebar Switch

Choke Knob



Master Cylinder



14. FRONT WHEEL/FRONT SUSPENSION/ STEERING SYSTEM

Remove the four bolts, then remove the handlebar holders



Handlebar Holders

INSPECTION

Inspect the handlebar.
Cracks/bends/damage → Replace.



INSTALLATION

Install handlebar and handlebar holder, then tighten the four bolts.

Torque: 2.5 kgf-m (25 N-m, 18 lbf-ft)

Align the mark on the handlebar with the lower handlebar holder surface.

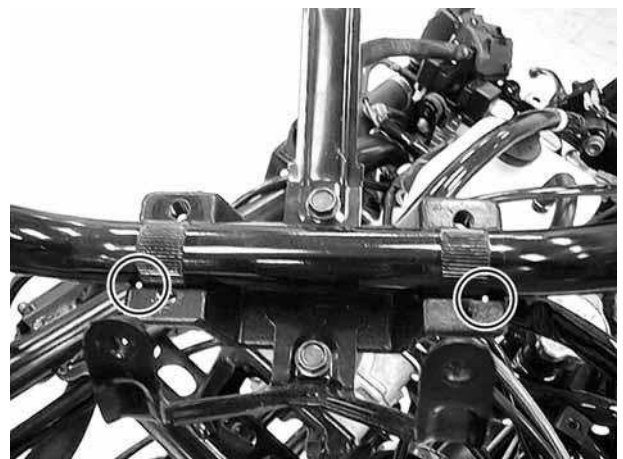

14. FRONT WHEEL/FRONT SUSPENSION STEERING SYSTEM

KYMCO
MXU 500 IRS

- Be sure the handlebar holder mark face to front.
- First tighten the bolts on the front side of the handlebar holder, and then tighten the bolts on the rear side.

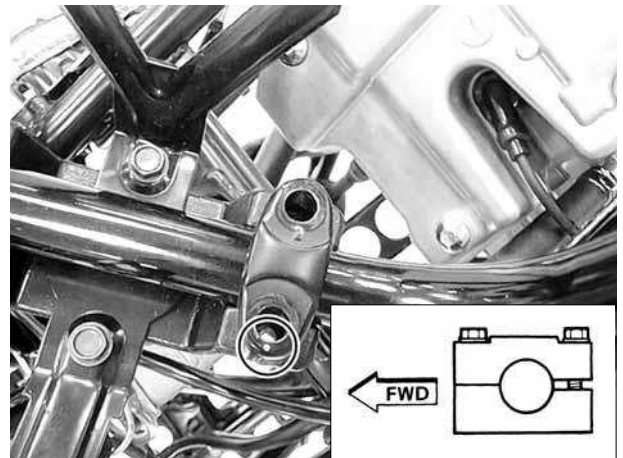

Install the handlebar switch by aligning the pin on the handlebar switch with the hole in the handlebar and then tighten the two screws securely.



Place the right and left brake master cylinder on the handlebar and install the master cylinder holder with the “UP” mark facing up, aligning the punch mark on the handlebar with the holder joint seam. First tighten the upper bolt and then tighten the lower blot.

Torque: 1.2 kgf-m (12 N-m, 8.6 lbf-ft)



14. FRONT WHEEL/FRONT SUSPENSION/ STEERING SYSTEM

KYMCO
MXU 500IRS

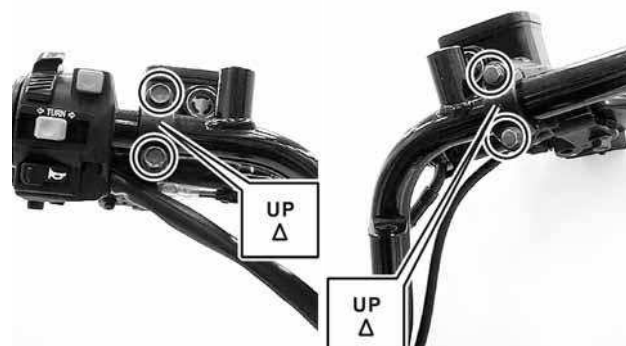

Install the throttle assembly by aligning the upper holder lip with the mark in the handlebar and then install the lower holder and tighten the two screws securely.



14. FRONT WHEEL/FRONT SUSPENSION STEERING SYSTEM

STEERING COLUMN REMOVAL/INSPECTION/ INSTALLATION

REMOVAL

Remove frame covers (refer to the “**FRAME COVERS**” section in the chapter 2).

Remove the tie-rods (refer to the “**TIE-ROD REMOVAL/INSPECTION/INSTALLATION**” section in this chapter).

Remove the handlebar (refer to the “**HANDLEBAR REMOVAL/INSPECTION/INSTALLATION**” section in this chapter).

Remove the two bolts and remove the cable holder.

Remove the steering brackets and dust seal.

Cable Holder



Steering Bracket

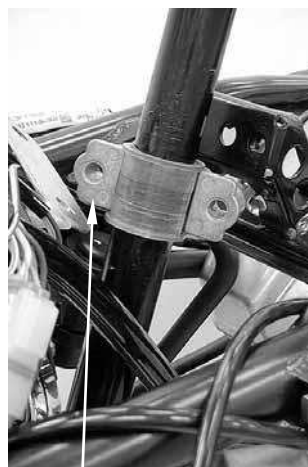

Steering Bracket

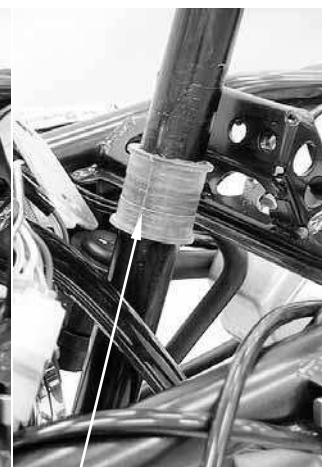

Dust Seal

14. FRONT WHEEL/FRONT SUSPENSION/ STEERING SYSTEM

Remove the cotter pin and nut from the steering column under the frame body, then remove steering column.



Remove the collar and dust seal.

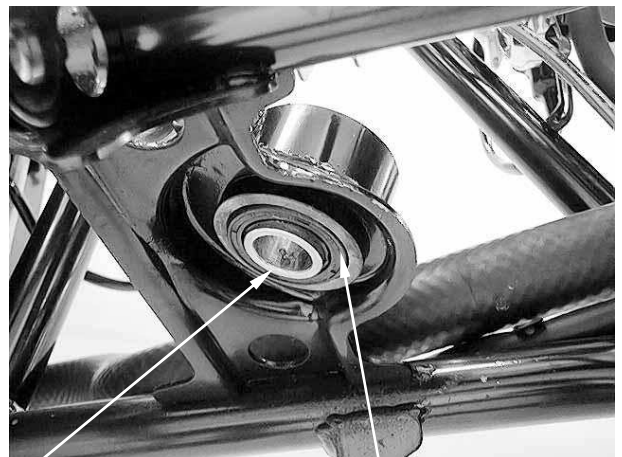

Collar

Dust Seal

Remove the dust seal.
Remove the snap ring.

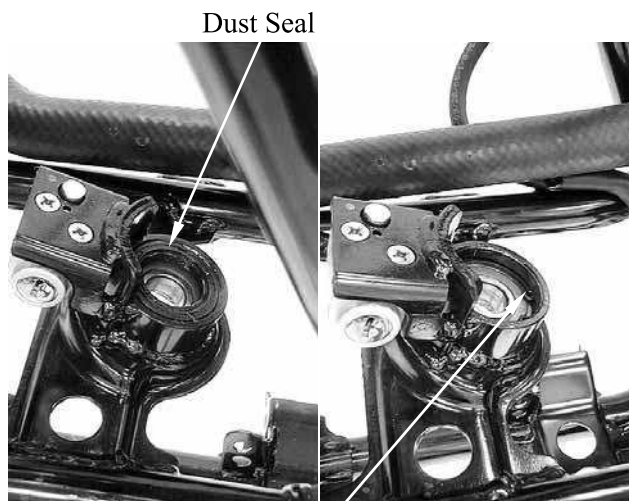

Dust Seal

Snap Ring

14. FRONT WHEEL/FRONT SUSPENSION STEERING SYSTEM

Replace the bearing by using the special tool.

Special tool:

Oil seal and bearing driver A120E00014



INSPECTION

Inspect the steering column.
Bends/damage →Replace.

Do not attempt to straighten a bent steering column, this may dangerously weaken the steering column.



Inspect the steering brackets and oil seal.
Wear damage →Replace.

INSTALLATION

Apply the grease onto the collar, dust seals, and bearing.

Install the steering column and collar, then tighten the nut under the frame body.

Torque: 7 kgf-m (70 N-m, 50 lbf-ft)

Install the cotter pin and band ends of cotter pin.

Always use a new cotter pin.



14. FRONT WHEEL/FRONT SUSPENSION/ STEERING SYSTEM

KYMCO
MXU 500IRS

Install the dust seal, steering brackets and cable holder.

Install and tighten the two bolts to the specified torque.

Torque: 2.2 kgf-m (22 N-m, 16 lbf-ft)

Steering Bracket



Cable Holder



REAR WHEEL/AXLE/SHOCK ABSORBER/SWING ARM

| | |
|---|-------|
| SERVICE INFORMATION----- | 15- 2 |
| TROUBLESHOOTING----- | 15- 2 |
| REAR WHEEL REMOVAL/INSPECTION/INSTALLATION ----- | 15- 3 |
| REAR WHEEL HUB REMOVAL/INSPECTION/ INSTALLATION ----- | 15- 4 |
| REAR SHOCK ABSORBER REMOVAL/INSPECTION/ INSTALLATION ----- | 15- 6 |
| STEERING KNUCKLE REMOVAL/INSPECTION/ INSTALLATION ----- | 15- 7 |

15. REAR WHEEL/AXLE/SHOCK ABSORBER/SWING ARM

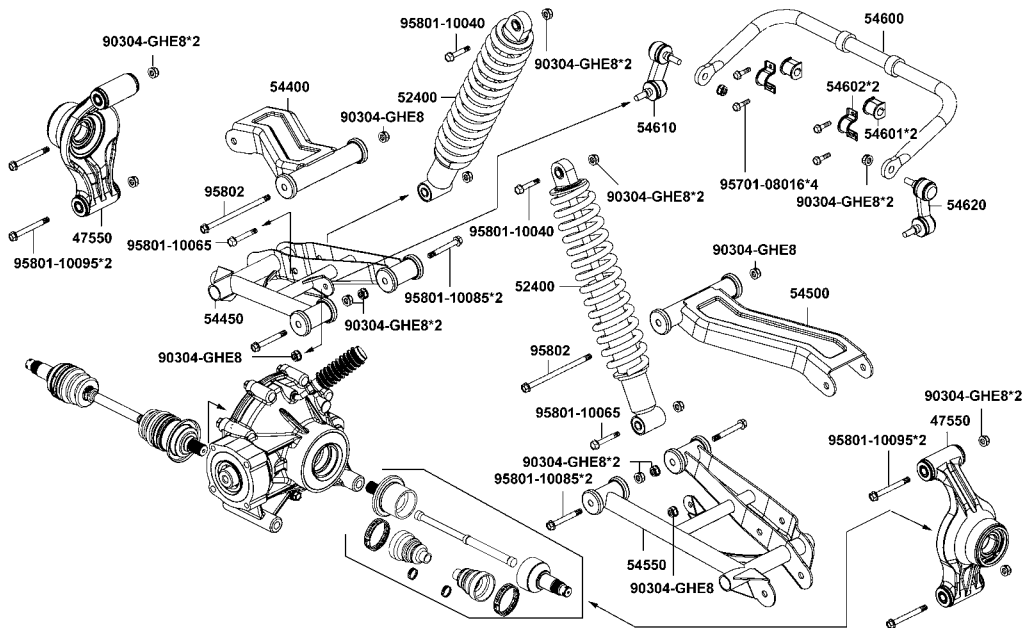
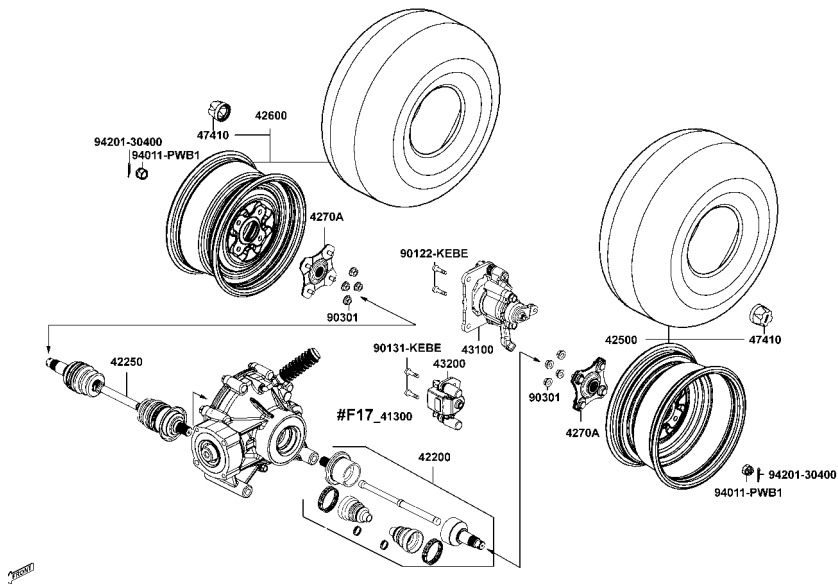

15. REAR WHEEL/AXLE/SHOCK ABSORBER/SWING ARM



SERVICE INFORMATION

GENERAL INSTRUCTIONS

- Jack the machine front wheel off the ground and be careful to prevent the machine from falling down.
- During servicing, keep oil or grease off the brake disk
- Inspect the brake system before riding.

SPECIFICATIONS

Unit: mm (in)

| Item | | Standard | Service Limit | |
|------------|-------------|----------|---------------|----------|
| Rear wheel | Rim run out | Radial | — | 2 (0.08) |
| | | Axial | — | 2 (0.08) |

TORQUE VALUES

| | |
|--------------------------------------|--------------------------------|
| Rear wheel nut | 5.5 kgf-m (55 N-m, 40 lbf-ft) |
| Rear shock absorber upper mount bolt | 4 .5kgf-m (45N-m, 32 lbf-ft) |
| Rear shock absorber lower mount bolt | 4 .5kgf-m (45 N-m, 32 lbf-ft) |
| Rear wheel hub nut | 20 kgf-m (200 N-m, 145 lbf-ft) |

SPECIAL TOOLS

| | |
|---------------------------|------------|
| Oil seal & bearing driver | A120E00014 |
|---------------------------|------------|

TROUBLESHOOTING

Rear wheel wobbling

- Bent rim
- Faulty tire
- Axle not tightened properly

Soft rear shock absorber

- Weak shock absorber spring
- Faulty damper

15. REAR WHEEL/AXLE/SHOCK ABSORBER/SWING ARM

REAR WHEEL REMOVAL/INSPECTION/ INSTALLATION

REMOVAL

Place the machine on a level place.
Remove four nuts from rear wheel.

Elevate the rear wheels by placing a suitable stand under the frame.

Support the machine securely so there is no danger of it falling over.

Remove the rear wheel and wheel hub nut cap together.



INSPECTION

Measure the wheel run out.
Replace wheel or check bearing play if out of specification

Rim run out limits:

Vertical: 2 mm (0.08 in)

Lateral: 2 mm (0.08 in)

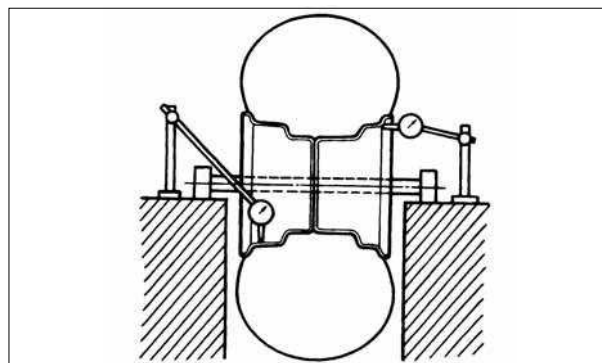

INSTALLATION

When reinstalling a wheel, tighten the wheel nuts in a crisscross (rather than a circular) pattern.

Torque: 5.5 kgf-m (55 N-m, 40 lbf-ft)

Be sure the tapered side of the wheel nuts face the wheel rim.

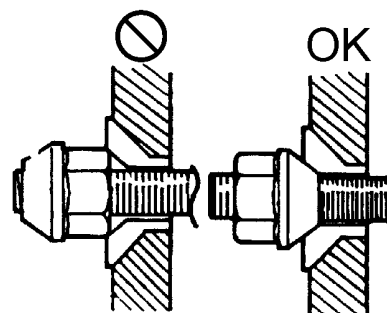

15. REAR WHEEL/AXLE/SHOCK ABSORBER/SWING ARM

REAR WHEEL HUB REMOVAL/INSPECTION/ INSTALLATION

REMOVAL

Place the machine on a level place.
Remove the rear wheel (refer to the “**REAR WHEEL REMOVAL/INSPECTION/INSTALLATION**” section in this chapter)
Elevate the rear wheels by placing a suitable stand under the frame.

Support the machine securely so there is no danger of it falling over.

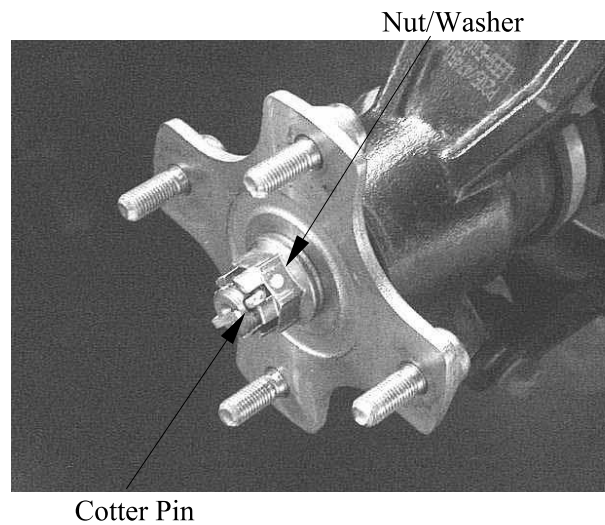

Remove the cotter pin.

Apply the rear brake and then remove nut and rear wheel hub.

INSPECTION

Check the wheel hub for cracks or deamage.
Check the wheel hub splines for wear or damage.

Apply grease

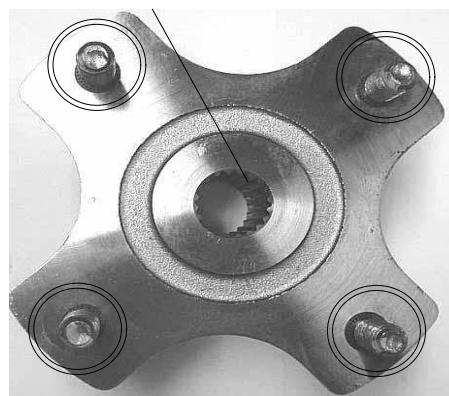

15. REAR WHEEL/AXLE/SHOCK ABSORBER/SWING ARM

INSTALLATION

Install the wheel hub and nut.

Apply lightweight lithium-soap base grease onto the wheel hub splines, rear axle splines and dust seal lips of the axle housing.

Apply grease

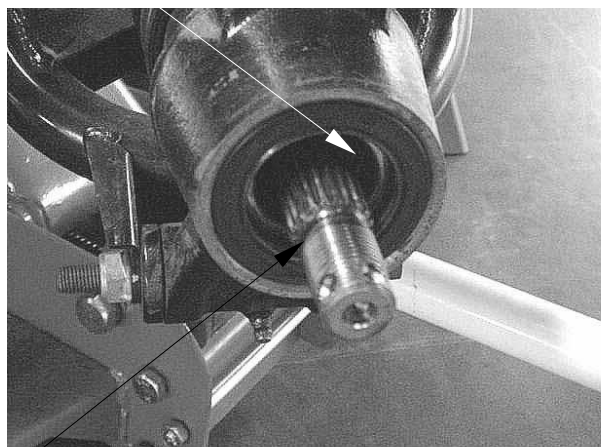

Apply grease

Apply the front brake and then tighten the nut to the specified torque.

Torque: 20 kgf-m (200 N-m, 145 lbf-ft)

Install the cotter pin and band ends of cotter pin.

Nut /Washer

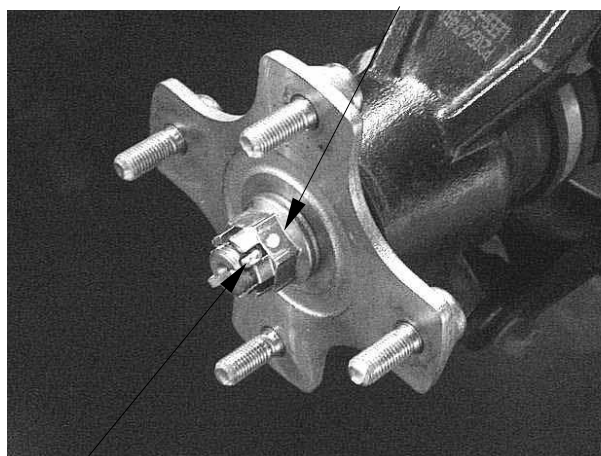

Cotter Pin

- Do not apply oil to the seat of the nut.
- Do not loosen the wheel hub nut after torque tightening. If the wheel hub nut groove is not aligned with the cotter pin hole, align groove with the hole by tightening up on the wheel hub nut.

Always use a new cotter pin.

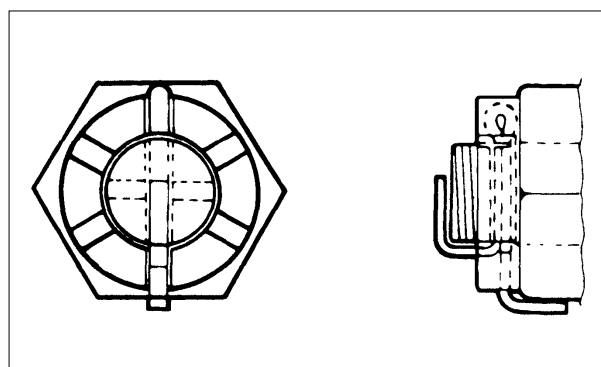

15. REAR WHEEL/AXLE/SHOCK ABSORBER/SWING ARM

REAR SHOCK ABSORBER REMOVAL/INSPECTION/ INSTALLATION

REMOVAL

Remove the rear shock absorber upper mount nut and washer.

Remove the lower mount bolt/nut, then remove the rear shock absorber.



INSPECTION

Inspect the shock absorber rod.

Bends/damage → Replace the shock absorber assembly.

Inspect the shock absorber.

Oil leaks → Replace the shock absorber assembly.

Inspect the spring of the shock absorber by move the spring up and down.

Fatigue → Replace the shock absorber assembly.

Inspect bushes, collar and dust seals.

Wear/damage → Replace.

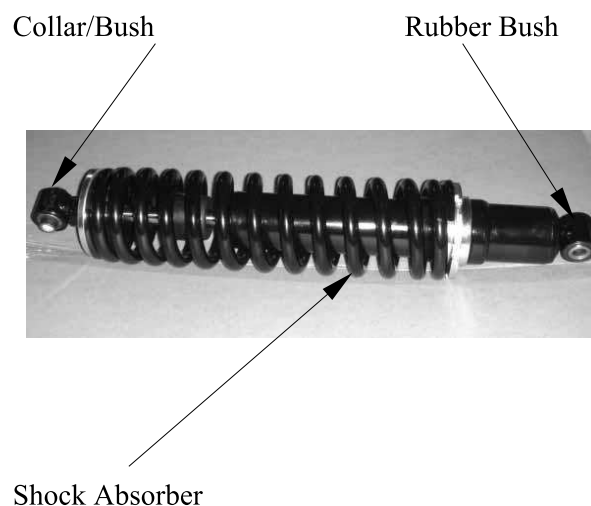

INSTALLATION

Apply the grease onto the bushes then install the shock absorber and tighten the lower mount bolt/nut to the specified torque.

Torque: 4.5 kgf-m (45 N-m, 32 lbf-ft)

Install and tighten the upper mounting nut to the specified torque.

Torque: 4.5 kgf-m (45 N-m, 32 lbf-ft)



15. REAR WHEEL/AXLE/SHOCK ABSORBER/SWING ARM

STEERING KNUCKLE REMOVAL/INSPECTION/ INSTALLATION

REMOVAL

Elevate the rear wheels by placing a suitable stand under the frame.

Support the machine securely so there is no danger of it falling over.

Remove the rear wheel hub

Remove the cotter pin and nut from the tie-rod end.

Remove the 2 bolts

Remove the knuckle from the upper and lower arms

Apply grease

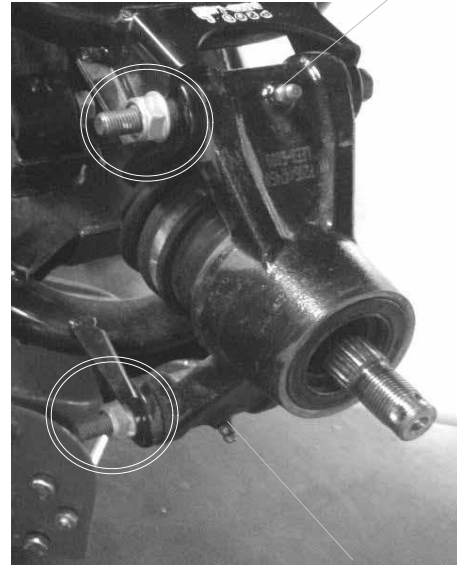

Apply grease

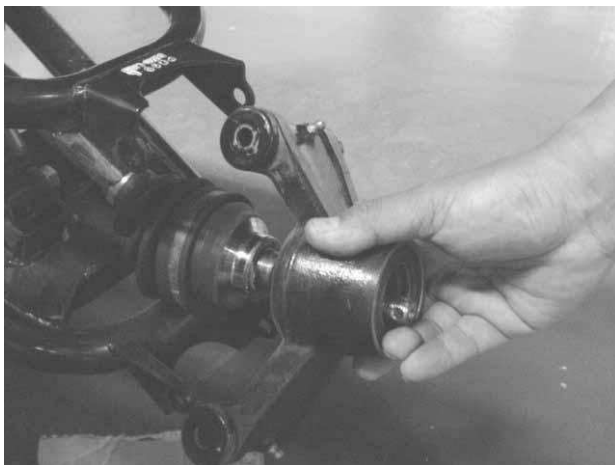
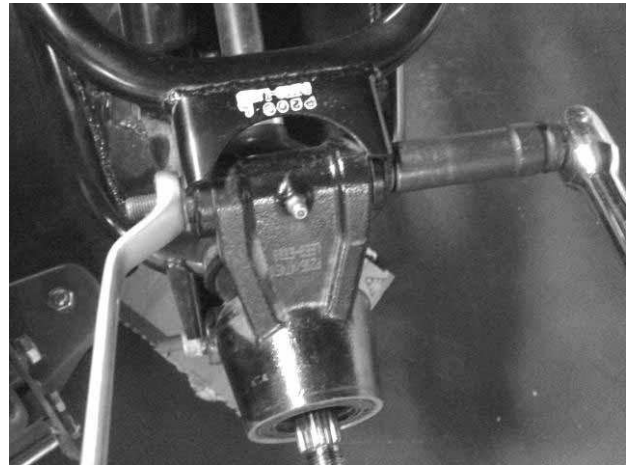

15. REAR WHEEL/AXLE/SHOCK ABSORBER/SWING ARM

INSPECTION

Inspect the knuckle end boot for wear or damage.

If any damages are found, replace the knuckle end with a new one.

Knuckle End Boot



Dust Seal

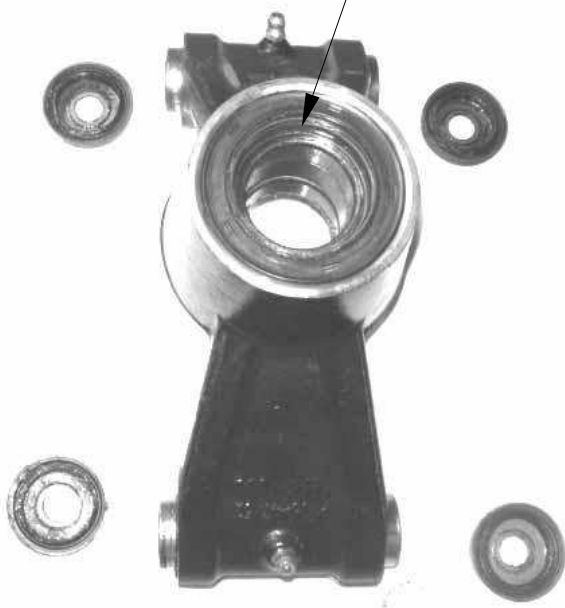

Dust Seal



15. REAR WHEEL/AXLE/SHOCK ABSORBER/SWING ARM

INSTALLATION

Install the tie-rod onto the steering knuckle and tighten the nut to the specified torque.

Torque: 4.8 kgf - m (48 N·m, 34 lbf - ft)

Install the lock 2 bolts

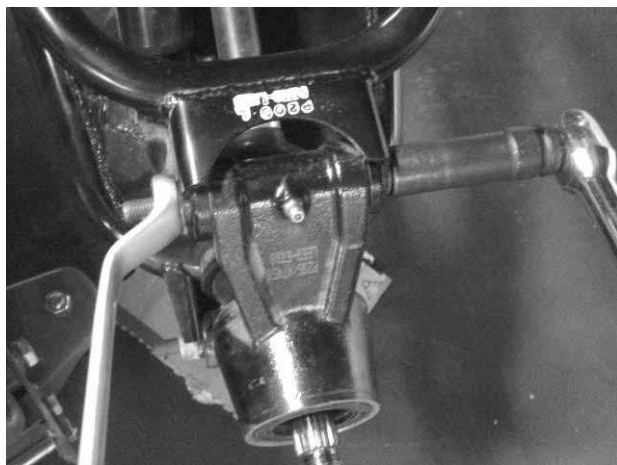

- Do not apply oil to the seat of the nuts.
- Do not loosen the nuts after torque tightening. If the nuts groove is not aligned with the cotter pins hole, align groove with the hole by tightening up on the nuts.

Apply grease

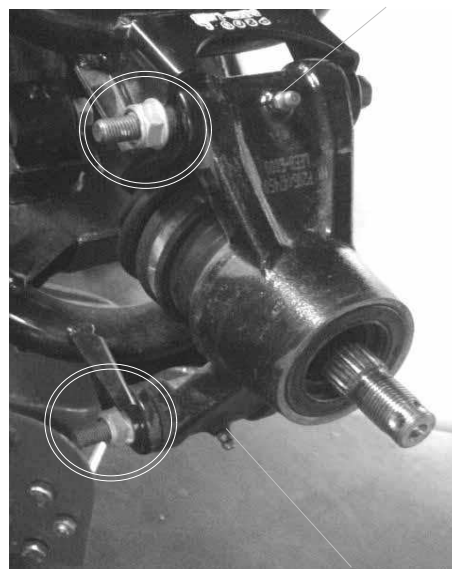

Apply grease

15. REAR WHEEL/AXLE/SHOCK ABSORBER/SWING ARM

STEERING KNUCKLE DISASSEMBLY/ASSEMBLY

DISASSEMBLY

Remove the dust seals.

Inspect the inner race play of the bearing by hand while it is in the steering knuckle.

Rotate the inner race by hand to inspect for abnormal noise and smooth rotation.

If there is anything unusual, replace the bearing with a new one.

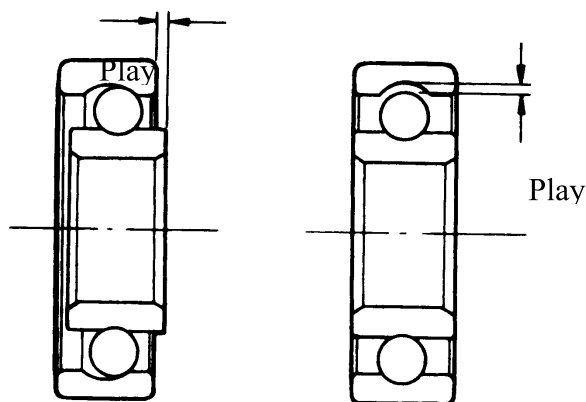
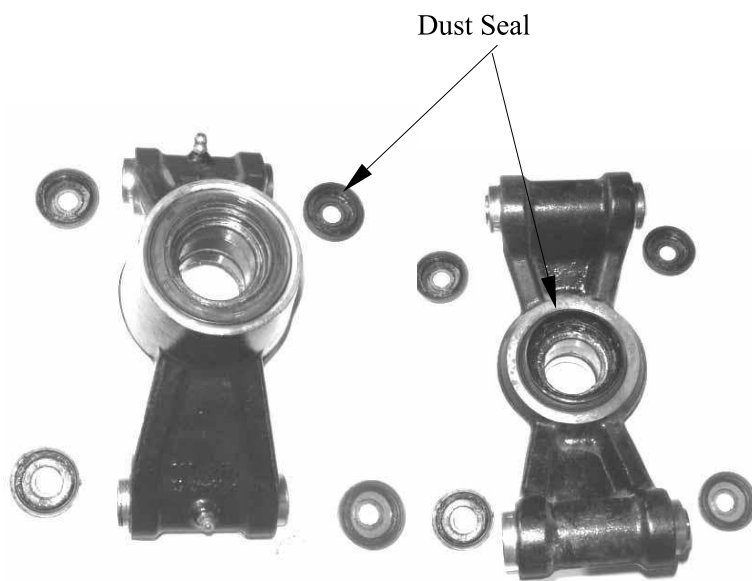

Remove the bearings using the appropriate bar, then remove the spacer.



15. REAR WHEEL/AXLE/SHOCK ABSORBER/SWING ARM

ASSEMBLY

Apply lightweight lithium-soap base grease to the new bearings of the steering knuckle and lips of the new dust seal before install them.



Install the new inner bearing by using the special tool.

Special tool:
Oil seal and bearing driver A120E00014

Install the spacer into the steering knuckle.

Make sure the long side of the spacer faces the outer bearing



Bearing Driver

Duct Seal

Install the new outer bearing by using the special tool.

Special tool:
Oil seal and bearing driver A120E00014



Bearing Driver



Install the new dust seals by using the special tool.

Special tool:
Oil seal and bearing driver A120E00014

BRAKE SYSTEM

| | |
|---|-------|
| SERVICE INFORMATION----- | 16- 2 |
| TROUBLESHOOTING----- | 16- 3 |
| BRAKE PADS REPLACEMENT----- | 16- 4 |
| FRONT BRAKE DISCS REMOVAL/INSPECTION/ INSTALLATION----- | 16- 9 |
| REAR BRAKE DISC REMOVAL/INSPECTION/ INSTALLATION----- | 16-10 |
| FRONT BRAKE FLUID CHANGE/AIR BLEED----- | 16-11 |
| REAR BRAKE FLUID CHANG/AIR BLEED----- | 16-14 |
| COMBINATION BRAKE FLUID CHANG/ AIR BLEED----- | 16-17 |
| BRAKE MASTER CYLINDERS REMOVAL/INSPECTION/ INSTALLATION ----- | 16-23 |
| BRAKE MASTER CYLINDER DISASSEMBLY/INSPECTION/ ASSEMBLY----- | 16-28 |
| DELAY VALVE REMOVAL/DISASSEMBLY/INSPECTION/ ASSEMBLY/INSTALLATION----- | 16-31 |
| FRONT BRAKE CALIPERS REMOVAL/INSPECTION/ INSTALLATION----- | 16-34 |
| REAR BRAKE CALIPERS REMOVAL/INSPECTION/ INSTALLATION----- | 16-35 |
| REAR BRAKE/PARKING BRAKE CALIPER REMOVAL/ INSPECTION/INSTALLATION----- | 16-36 |
| BRAKE CALIPER DISASSEMBLY/INSPECTION/ASSEMBLY-- | 16-37 |
| REAR BRAKE/PARKING BRAKE CALIPER DISASSEMBLY/INSPECTION/ASSEMBLY----- | 16-40 |

16. BRAKE SYSTEM

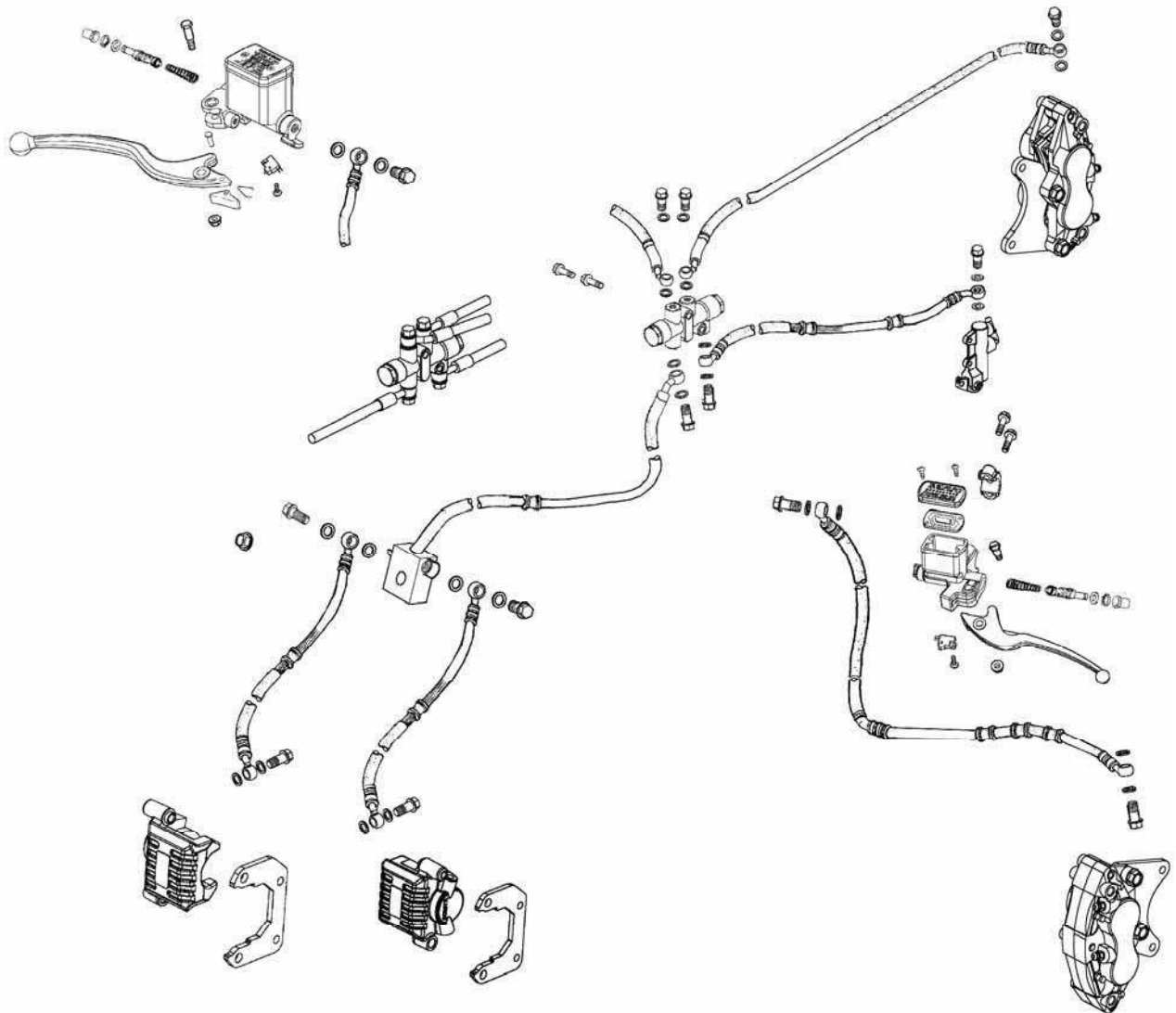

SERVICE INFORMATION

GENERAL INSTRUCTIONS

- During servicing, keep oil or grease off the brake pads and brake disk.
- Drain the brake fluid from the hydraulic brake system before disassembly.
- Contaminated brake disk or brake pads reduce stopping power. Clean the contaminated brake disk with high-performance brake degreaser and replace the brake pads.
- Do not use brake fluid for cleaning.
- Bleed air from the brake system if the brake system is removed or the brake is soft.
- Do not allow any foreign matters entering the brake reservoir when filling the brake reservoir with brake fluid.
- Brake fluid will damage painted, coated surfaces and plastic parts. When working with brake fluid, use shop towels to cover and protect painted, rubber and plastic parts. Wipe off any splash of brake fluid with a clean towel. Do not wipe the machine with a towel contaminated by brake fluid.
- Make sure to use recommended brake fluid. Use of other unspecified brake fluids may cause brake failure.
- Inspect the brake operation before riding.

SPECIFICATIONS

Unit: mm (in)

| Item | Standard | Service Limit |
|----------------------|-----------------------------|------------------------|
| Brake disk thickness | FR:4.0(0.156) RR:5.0(0.195) | FR:3 (0.12)RR:4(0.156) |
| Brake disk runout | — | 0.3 (0.012) |

TORQUE VALUES

| | |
|-------------------------------|---------------------------------|
| Caliper mounting bolt | 2.7 kgf-m (27N-m, 19.5 lbf-ft) |
| Brake pad mounting bolt | 1.8 kgf-m (18 N-m, 13 lbf-ft) |
| Brake disc bolt | 3.5 kgf-m (35 N-m, 25.2 lbf-ft) |
| Bleed valve nut | 0.6 kgf-m (6 N-m, 4.32 lbf-ft) |
| Brake hose bolt | 3.5 kgf-m (35 N-m, 35 lbf-ft) |
| Master cylinder mounting bolt | 1.2 kgf-m (12 N-m, 8.6 lbf-ft) |
| Delay valve mounting bolt | 1.2 kgf-m (12 N-m, 8.6 lbf-ft) |
| Delay valve plug | 5 kgf-m (50 N-m, 36 lbf-ft) |

TROUBLESHOOTING

Loose brake lever

- Air in hydraulic brake system
- Brake fluid level too low
- Hydraulic brake system leakage

Poor brake performance

- Air in brake system
- Deteriorated brake fluid
- Contaminated brake pads and brake disk
- Worn brake pads
- Worn brake master cylinder piston oil seal
- Clogged brake fluid line
- Deformed brake disk
- Unevenly worn brake caliper

Tight brake lever

- Seized piston
- Clogged hydraulic brake system
- Smooth or worn brake pad

Brake noise

- Contaminated brake pad surface
- Excessive brake disk run out
- Incorrectly installed caliper
- Brake disk or wheel not aligned

Hard braking

- Seized hydraulic brake system
- Seized piston

BRAKE PADS REPLACEMENT

FRONT BRAKE PADS

Remove the front wheel. (refer to the “**FRONT WHEEL REMOVAL/INSPECTION/INSTALLATION**” section in the chapter 14).

Remove the two brake pad pins from the brake caliper.

Remove the two mounting bolts from brake caliper and then remove brake caliper.

- Do not operate the brake lever during or after brake pad removal.
- Replace the brake pads as a set, otherwise braking performance will be adversely affected.

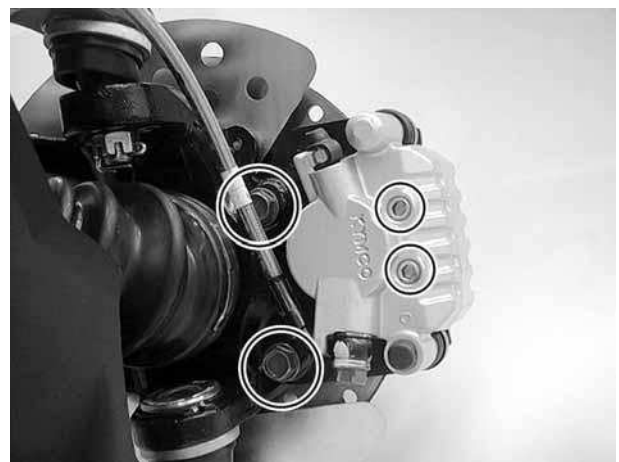

Compress the brake caliper holder and remove brake pads.



16. BRAKE SYSTEM

A wear indicator is provided on each brake. The indicators allows checking of brake pads wear. Check the position of the indicator.

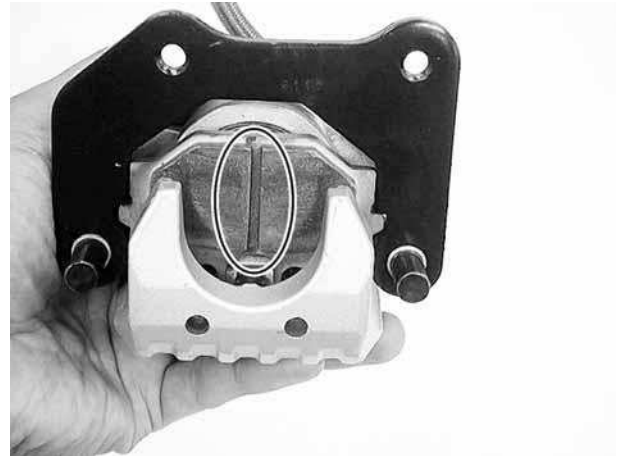

Install the new brake pads.

Install the brake pad mounting pins.
Install the brake caliper mounting bolts to the specified torque.

Torque: 2.7 kgf-m (27 Nm, 19.5 lbf-ft)

Tighten the brake pad mounting pins.

Torque: 1.8 kgf-m (18 Nm, 13 lbf-ft)



REAR BRAKE PADS

The replacement of rear brake and front brake pads are the same.



REAR BRAKE PADS

Rear brake



The replacement of rear brake and front brake pads are the same.

Rear brake (combined)

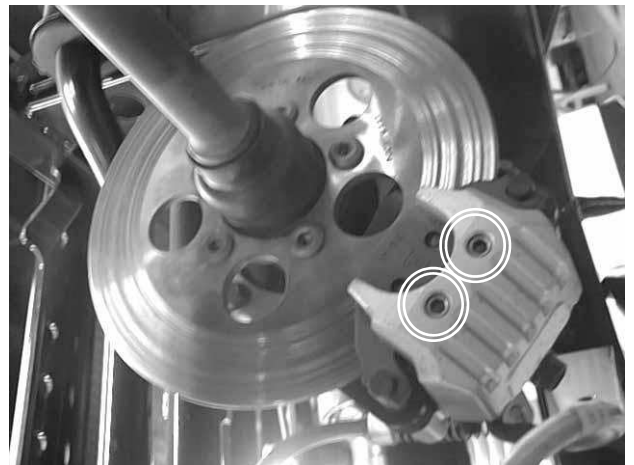

Remove the two brake pad pins from the brake caliper.

Remove the two mounting bolts from brake caliper and then remove brake caliper.

- Do not operate the brake lever during or after brake pad removal.
- Replace the brake pads as a set, otherwise braking performance will be adversely affected.



16. BRAKE SYSTEM

Compress the brake caliper holder and remove brake pads.



A wear indicator is provided on each brake. The indicators allows checking of brake pads wear. Check the position of the indicator.

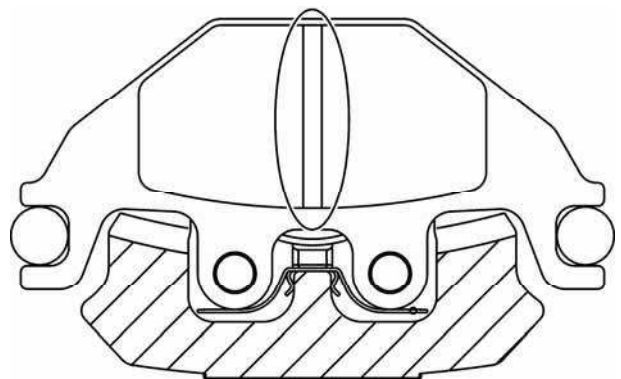

Install the new brake pads.
Install the brake pad mounting pins.



16. BRAKE SYSTEM

Install the brake caliper mounting bolts to the specified torque.

Torque: 2.7 kgf-m (27 Nm, 19.5lbf-ft)

Tighten the brake pad mounting pins.

Torque: 1.8 kgf-m (18 Nm, 13 lbf-ft)



FRONT BRAKE DISCS REMOVAL/INSPECTION/ INSTALLATION

REMOVAL

Remove the front wheel hub (refer to the “**FRONT WHEEL HUB REMOVAL/INSPECTION/INSTALLATION**” section in the chapter 14).

Remove the four bolts and then remove the brake disc.

INSPECTION

Measure the brake disc thickness.

Service Limit: 3 mm (0.12 in)

Measure the brake disk run out.

Service Limit: 0.3 mm (0.012 in)

INSTALLATION

Install the brake disc onto the wheel hub.
Install and tighten the new four bolts to the specified torque.

Torque: 3.5 kgf-m (35 Nm, 25.2 lbf-ft)



Brake Disc

REAR BRAKE DISC REMOVAL/INSPECTION/ INSTALLATION

REMOVAL

- Remove the rear wheel hub
- Remove the rear wheels.
- Remove the rear drive bolts.
- Disconnect the rear drive and shaft
- Rear propeller connect position(holder disk rear brake).
- Remove the rear drive
- Remove the 5 bolts and then remove the brake disc.(Use the impact driver remove it)

INSPECTION

Measure the brake disc thickness.

Service Limit: 4 mm (0.16 in)

Measure the brake disk run out.

Service Limit: 0.3 mm (0.012 in)

INSTALLATION

- Install the brake disc onto the wheel hub.
- Install and tighten the new four bolts to the specified torque.

Torque: 3.5 kgf-m (35 Nm, 25.2 lbf-ft)

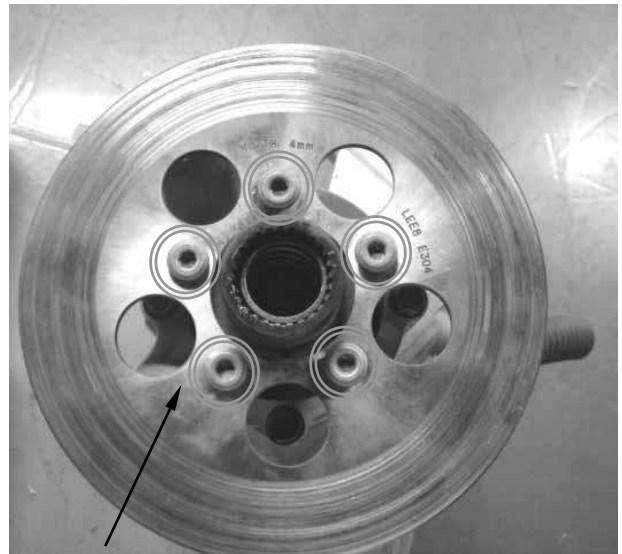

Brake Disc



Impact Driver



FRONT BRAKE FLUID CHANGE/AIR BLEED (OFF ROAD)

BRAKE FLUID CHANGE

Place the machine on the level ground and set the handlebar upright.
Remove the two screws from the brake fluid reservoir cap.

Use shop towels to cover plastic parts and coated surfaces to avoid damage caused by splash of brake fluid.

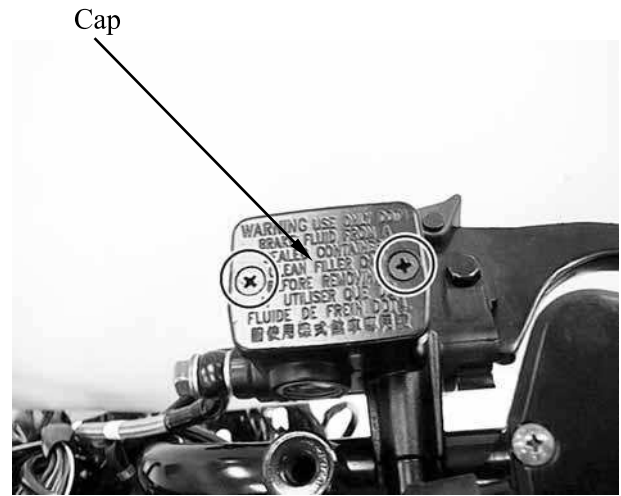

Connect a transparent hose to the brake caliper bleed valve (right and calipers) and then loosen the bleed valve nuts.
Use a syringe to draw the brake fluid out through the hose. Then, tighten the bleed valve nuts.

Torque: 0.6 kgf-m (6 Nm, 4.32 lbf-ft)

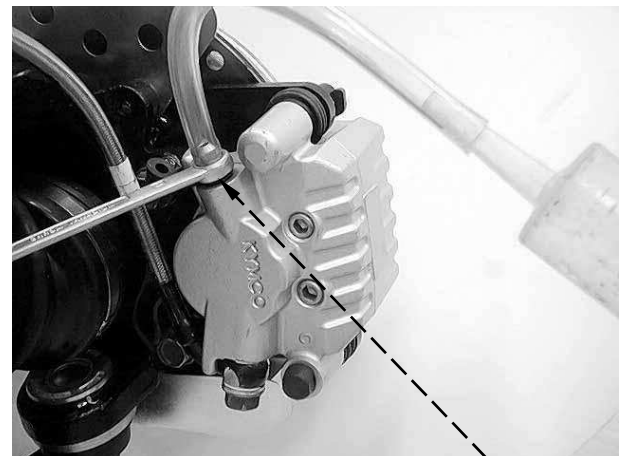

Bleed Valve Nut

Fill the brake reservoir with brake fluid.

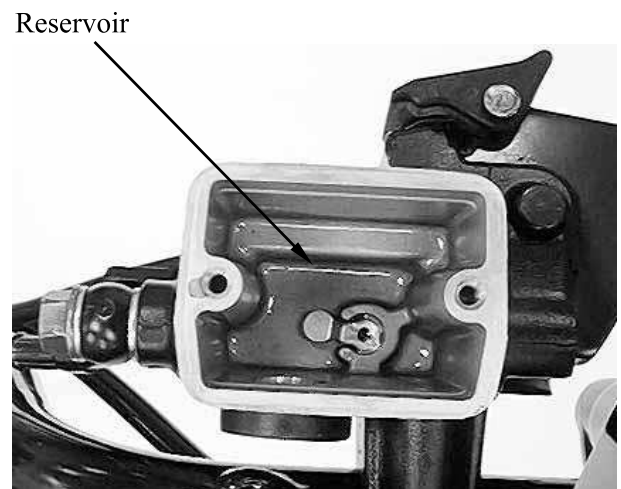

Connect a transparent hose to the right caliper bleed valve and then loosen the bleed valve nuts.

Use the syringe to draw brake fluid into it until there is no air bubbles in the transparent hose.

Then, tighten the bleed valve nut.

Torque: 0.6 kgf-m (6 Nm, 4.32 lbf-ft)

Connect a transparent hose to the left caliper bleed valve and then loosen the bleed valve nuts.

Use the syringe to draw brake fluid into it until there is no air bubbles in the transparent hose.

Then, tighten the bleed valve nut.

Torque: 0.6 kgf-m (6 Nm, 4.32 lbf-ft)

- When drawing brake fluid with the syringe, the brake fluid level should be kept over 1/2 of the brake reservoir height.
- Use only the recommended brake fluid.

Recommended Brake Fluid: DOT-4

BRAKE SYSTEM BLEEDING

1. Connect a transparent hose to the bleed valves (right and left caliper).
2. Fully apply the brake lever after continuously pull it several times. Then, loosen the right caliper bleed valve nut to bleed air from the brake system.
3. Fully apply the brake lever after continuously pull it several times. Then, loosen the left caliper bleed valve nut to bleed air from the brake system.
4. Repeat these steps until the brake system is free of air.

When bleeding air from the brake system, the brake fluid level should be kept over 1/2 of the brake reservoir height.

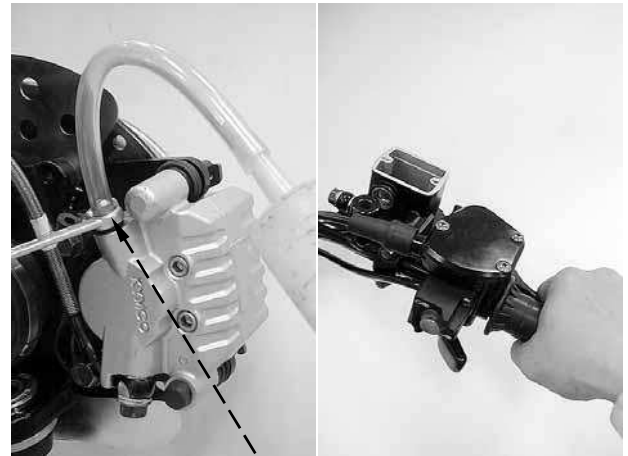

Bleed Valve

REAR BRAKE FLUID CHANGE/AIR BLEED

BRAKE LEVER

Brake fluid change

Place the machine on the level ground and set the handlebar upright.

Remove the brake fluid reservoir cap.

Use shop towels to cover plastic parts and coated surfaces to avoid damage caused by splash of brake fluid.



Reservoir Cap

Connect a transparent hose to the brake caliper bleed valve and then loosen the bleed valve nut.

Use a syringe to draw the brake fluid out through the hose.

Fill the brake reservoir with brake fluid and use the syringe to draw brake fluid into it until there is no air bubbles in the transparent hose.

Then, tighten the bleed valve nut.

Torque: 0.6 kgf-m (6 Nm, 4.32 lbf-ft)

- When drawing brake fluid with the syringe, the brake fluid level should be kept over 1/2 of the brake reservoir height.
- Use only the recommended brake fluid.

Recommended Brake Fluid: DOT-4

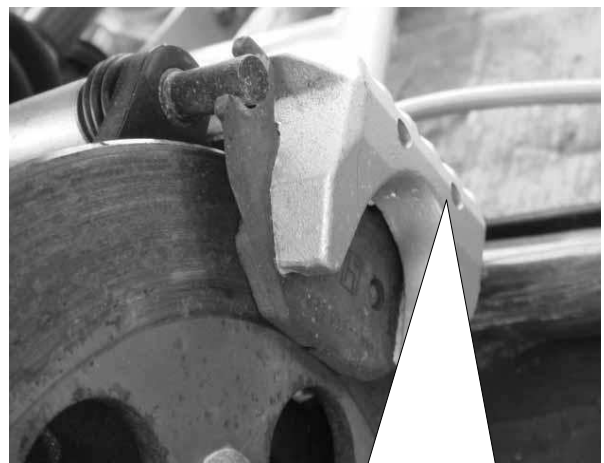

Bleed Valve

Brake system bleeding

1. Connect a transparent hose to the bleed valve.
2. Fully apply the brake lever after continuously pull it several times. Then, loosen the caliper bleed valve nut to bleed air from the brake system.
3. Repeat these steps until the brake system is free of air.

When bleeding air from the brake system, the brake fluid level should be kept over 1/2 of the brake reservoir height.

Bleed Valve

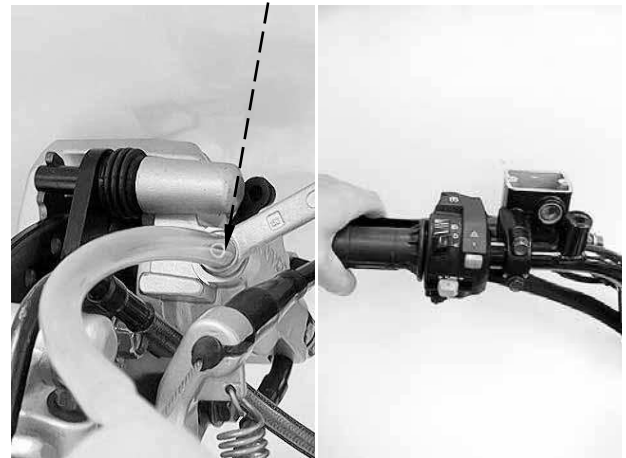

BRAKE PEDAL

Brake fluid change

Place the machine on the level ground and set the handlebar upright.

Remove the brake fluid reservoir cap.

Use shop towels to cover plastic parts and coated surfaces to avoid damage caused by splash of brake fluid.

Cap

Reservoir



16. BRAKE SYSTEM

Connect a transparent hose to the brake caliper bleed valve and then loosen the bleed valve nut. Use a syringe to draw the brake fluid out through the hose.

Fill the brake reservoir with brake fluid and use the syringe to draw brake fluid into it until there is no air bubbles in the transparent hose. Then, tighten the bleed valve nut.

Torque: 0.6 kgf-m (6 Nm, 4.32 lbf-ft)

- When drawing brake fluid with the syringe, the brake fluid level should be kept over 1/2 of the brake reservoir height.
- Use only the recommended brake fluid.

Recommended Brake Fluid: DOT-4

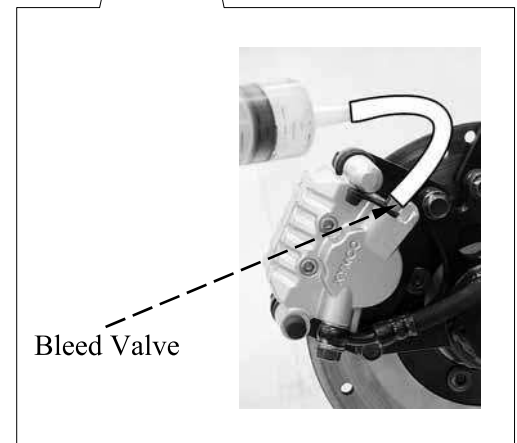
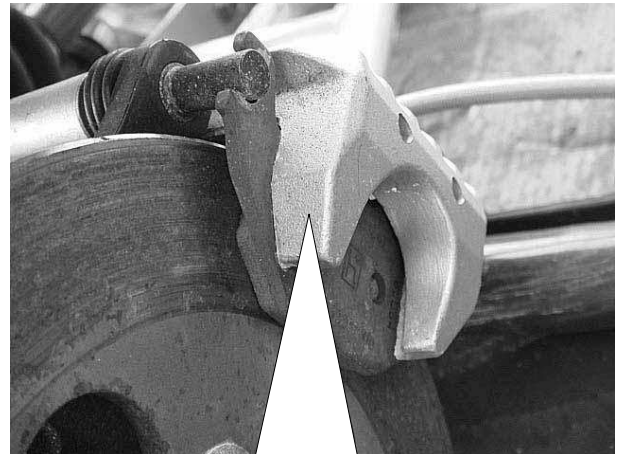

Brake system bleeding

1. Connect a transparent hose to the bleed valve.
2. Fully apply the brake pedal after continuously depress it several times. Then, loosen the caliper bleed valve nut to bleed air from the brake system.
3. Repeat these steps until the brake system is free of air.

When bleeding air from the brake system, the brake fluid level should be kept over 1/2 of the brake reservoir height.

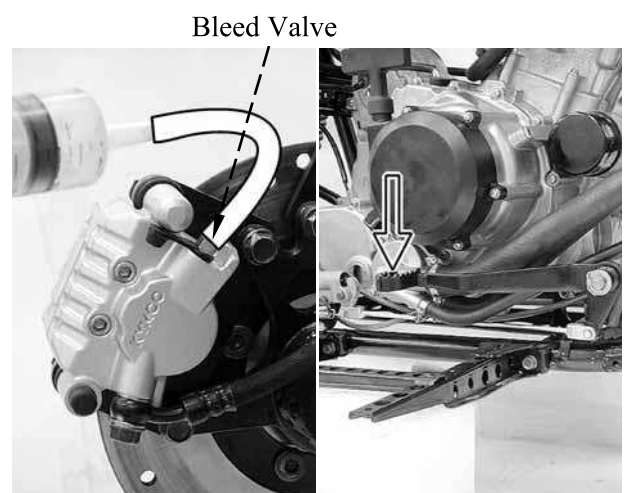

COMBINATION BRAKE FLUID CHANGE/AIR BLEED

BRAKE FLUID CHANGE

Place the machine on the level ground and set the handlebar upright.

1. Remove the two screws from the brake fluid reservoir cap.
2. Remove the brake fluid reservoir cap (front brake lever).

Use shop towels to cover plastic parts and coated surfaces to avoid damage caused by splash of brake fluid.

Cap



3. Connect a transparent hose to the delay valve bleed valve and then loosen the bleed valve nut. Use a syringe to draw the brake fluid out through the hose. Then tighten the bleed valve nut.

Torque: 0.6 kgf-m (6 Nm, 4.32 lbf-ft)

Bleed Valve



16. BRAKE SYSTEM

4. Remove the brake fluid reservoir cap (brake pedal).

Use shop towels to cover plastic parts and coated surfaces to avoid damage caused by splash of brake fluid.

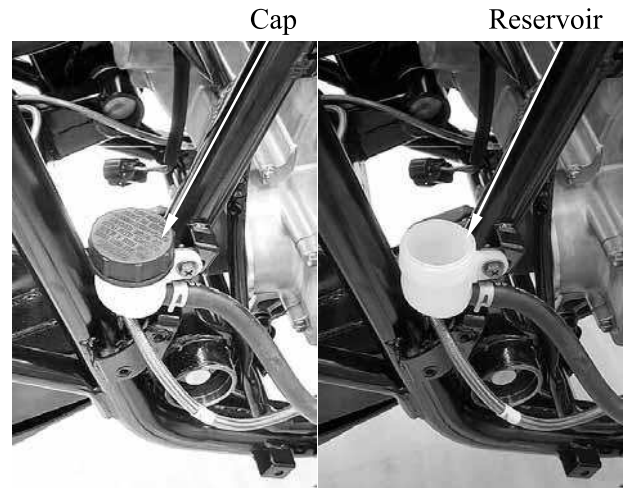

5. Connect a transparent hose to the front brake caliper bleed valve (front right and left calipers) and then loosen the bleed valve nut. Use a syringe to draw the brake fluid out through the hose. Then tighten the bleed valve nuts.

Torque: 0.6 kgf-m (6 Nm, 4.32 lbf-ft)

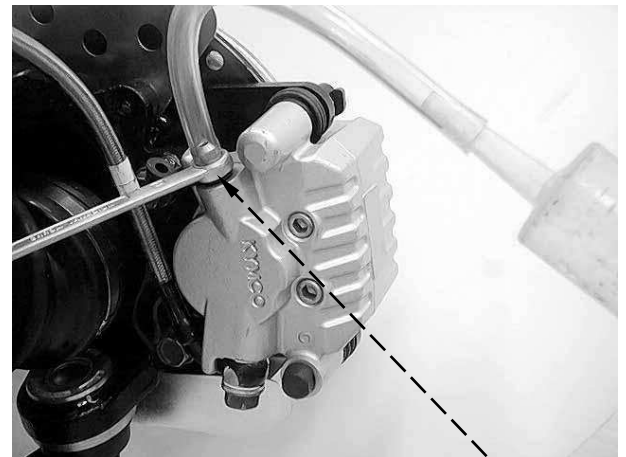

Bleed Valve Nut

6. Connect a transparent hose to the rear brake caliper bleed valve (combined) and then loosen the bleed valve nut. Use a syringe to draw the brake fluid out through the hose. Then tighten the bleed valve nut.

Torque: 0.6 kgf-m (6 Nm, 4.32 lbf-ft)

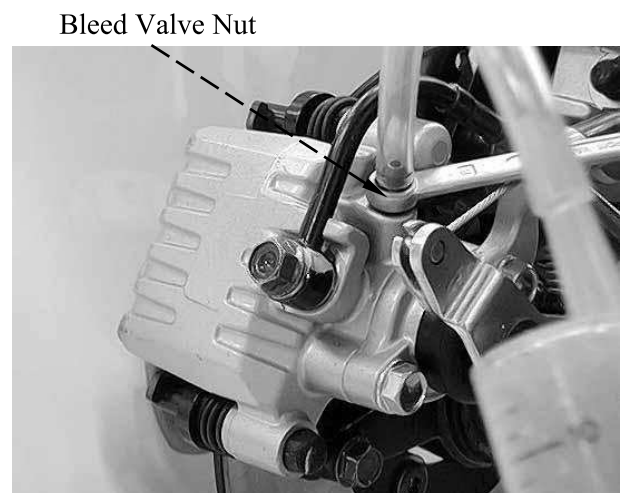

Bleed Valve Nut

16. BRAKE SYSTEM

7. Fill the brake reservoir (front brake lever) with brake fluid.

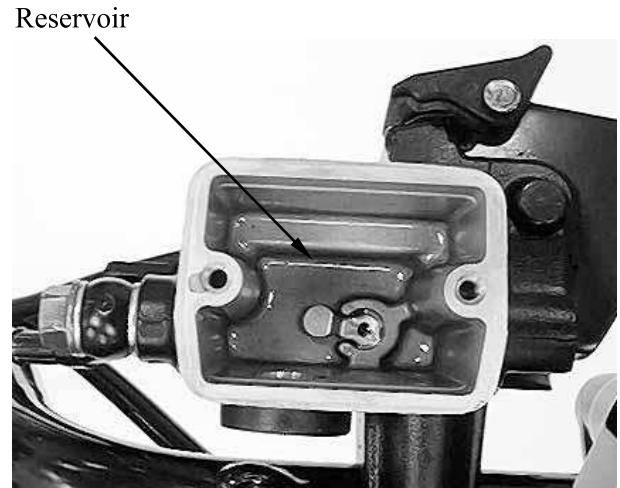

8. Loosen the delay valve bleed valve nut. Connect the transparent hose to the bleed valve. Use the syringe to draw brake fluid into it until there is no air bubbles in the transparent hose. Then, tighten the bleed valve nut.

Torque: 0.6 kgf-m (6 Nm, 4.32 lbf-ft)

- When drawing brake fluid with the syringe, the brake fluid level should be kept over 1/2 of the brake reservoir height (front brake lever).
- Use only the recommended brake fluid.

Recommended Brake Fluid: DOT-4

9. Fill the brake reservoir (brake pedal) with brake fluid.



16. BRAKE SYSTEM

10. Connect a transparent hose to the right caliper bleed valve and then loosen the bleed valve nuts.
Use the syringe to draw brake fluid into it until there is no air bubbles in the transparent hose.
Then, tighten the bleed valve nut.

Torque: 0.6 kgf-m (6 Nm, 4.32 lbf-ft)

Connect a transparent hose to the left caliper bleed valve and then loosen the bleed valve nuts.
Use the syringe to draw brake fluid into it until there is no air bubbles in the transparent hose.
Then, tighten the bleed valve nut.

Torque: 0.6 kgf-m (6 Nm, 4.32 lbf-ft)

- When drawing brake fluid with the syringe, the brake fluid level should be kept over 1/2 of the brake reservoir height (brake pedal).
- Use only the recommended brake fluid.

Recommended Brake Fluid: DOT-4

11. Loosen the rear caliper (combined) bleed valve nut. Connect the transparent hose to the bleed valve.
Use the syringe to draw brake fluid into it until there is no air bubbles in the transparent hose.
Then, tighten the bleed valve nut.

Torque: 0.6 kgf-m (6 Nm, 4.32 lbf-ft)

- When drawing brake fluid with the syringe, the brake fluid level should be kept over 1/2 of the brake reservoir height (brake pedal).
- Use only the recommended brake fluid.

Recommended Brake Fluid: DOT-4

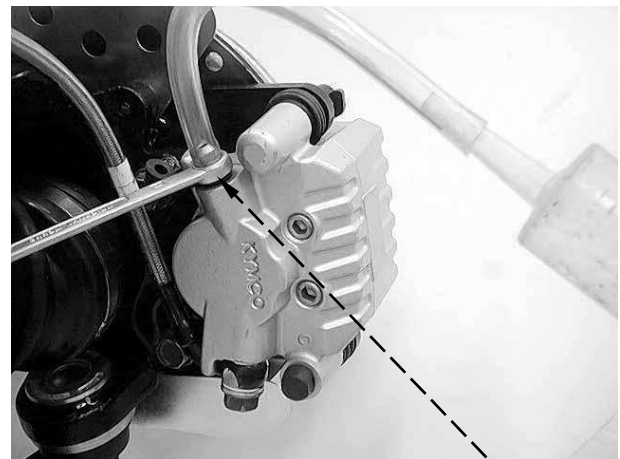

Bleed Valve Nut

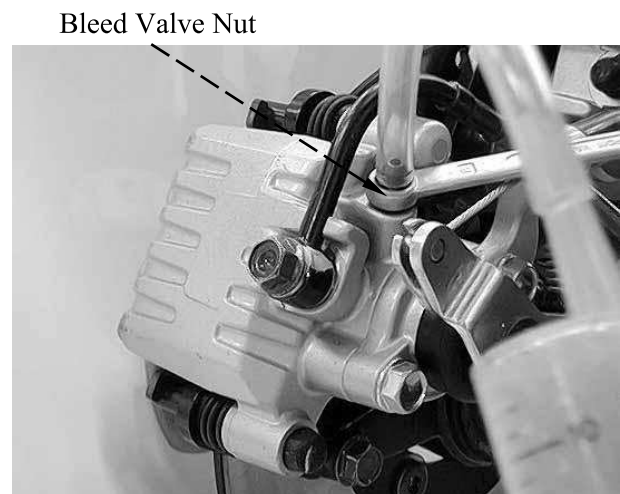

Bleed Valve Nut

16. BRAKE SYSTEM

DELAY VALVE BLEEDING

1. Connect a transparent hose to the bleed valve (delay valve).
2. Fully apply the front brake lever after continuously pull it several times. Then, loosen the bleed valve nut (delay valve) to bleed air between the front brake master cylinder and the delay valve.
3. Repeat these steps until between the front brake master cylinder and the delay valve is free of air. Then tighten the bleed valve nut.

Bleed Valve



Torque: 0.6 kgf-m (6 Nm, 4.32 lbf-ft)

When bleeding air from the brake system, the brake fluid level should be kept over 1/2 of the brake reservoir height (front brake lever).

COMBINATION BRAKE SYSTEM AIR BLEEDING

1. To finish delay valve bleeding (refer to above).
2. Connect a transparent hose to the rear caliper (combined) and front calipers bleed valves.
3. Fully apply the brake pedal after continuously depress it several times and fully apply the front brake lever after continuously pull it several times. Then, loosen the rear caliper bleed valve nut to bleed air from the brake system.
4. Fully apply the brake pedal after continuously depress it several times and fully apply the front brake lever after continuously pull it several times. Then, loosen the front right caliper bleed valve nut to bleed air from the brake system.
5. Fully apply the brake pedal after continuously depress it several times and fully apply the front brake lever after continuously pull it several times. Then, loosen the front left caliper bleed valve nut to bleed air from the brake system.



16. BRAKE SYSTEM

- Repeat these steps until the brake system is free of air. Then tighten the bleed valve nuts.

Torque: 0.6 kgf-m (6 Nm, 4.32 lbf-ft)

When bleeding air from the brake system, the brake fluid level should be kept over 1/2 of the brake reservoir height (brake pedal).

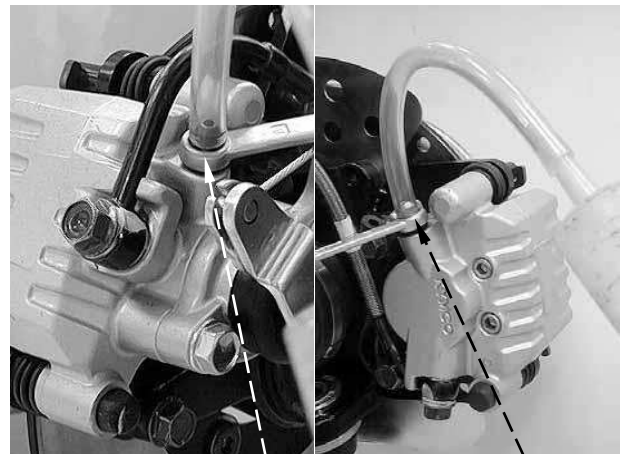

Bleed Valve

Bleed Valve

BRAKE MASTER CYLINDERS REMOVAL/INSPECTION/ INSTALLATION

REMOVAL

Front/rear master cylinder

Remove the brake reservoir cap and drain the brake fluid from the hydraulic brake system (refer to the “**FRONT BRAKE FLUID CHANGE/AIR BLEED (OFF ROAD)**” section or “**REAR BRAKE FLUID CHANGE/AIR BLEED**” section or “**COMBINATION BRAKE FLUID CHANGE/AIR BLEED (ON ROAD)**” in this chapter).

Do not splash brake fluid onto any rubber, plastic and coated parts. When working with brake fluid, use shop towels to cover these parts.

Remove the bolt/nut and then remove the brake lever.

Remove fluid hose bolt/two washers and then disconnect the fluid hose.

When removing the brake fluid hose bolt, be sure to place towels under the hose and plug the hose end to avoid brake fluid leakage and contamination.

Remove the two master cylinder holder bolts and remove the master cylinder.

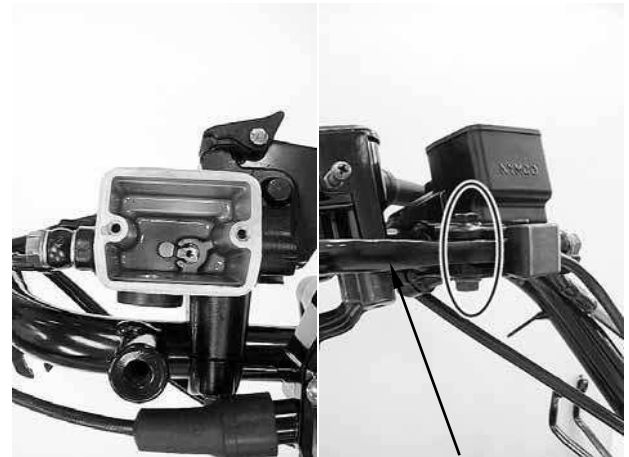

Brake Lever



16. BRAKE SYSTEM

Push the hole under the front brake master cylinder and then remove the brake light switch.

Remove the screw and then remove the brake light switch from the rear brake master cylinder.

Rear Brake Master Cylinder



Front Brake Master Cylinder

Brake pedal master cylinder

Remove the brake reservoir cap and drain the brake fluid from the hydraulic brake system (refer to the “**REAR BRAKE FLUID CHANGE/AIR BLEED**” section or “**COMBINATION BRAKE FLUID CHANGE/AIR BLEED (ON ROAD)**” section in this chapter).

Do not splash brake fluid onto any rubber, plastic and coated parts. When working with brake fluid, use shop towels to cover these parts.

Remove the joint then disconnect the fluid hose from the master cylinder.

Remove the bolt/nut then remove the brake arm from the master cylinder.

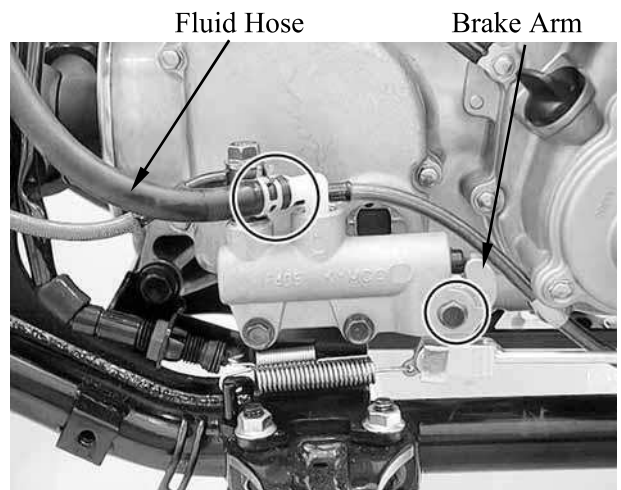

16. BRAKE SYSTEM

Remove fluid hose bolt/two washers and then disconnect the fluid hose.

When removing the brake fluid hose bolt, be sure to place towels under the hose and plug the hose end to avoid brake fluid leakage and contamination.

Remove the two mounting bolts and remove the master cylinder.

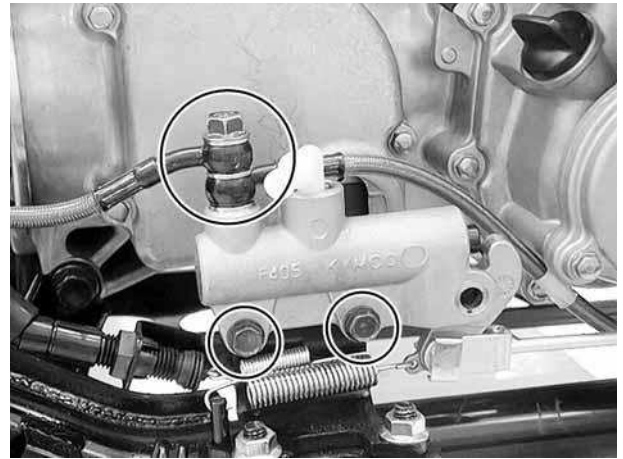

INSPECTION

Check the diaphragm to cracks or damage. If any damages are found, replace the diaphragm with a new one.



INSTALLATION

Front/rear master cylinder

Install the brake light switch.

Place the right and left brake master cylinder on the handlebar and install the master cylinder holder with the "UP" mark facing up, aligning the punch mark on the handlebar with the holder joint seam. First tighten the upper bolt and then tighten the lower blot.

Torque: 1.2 kg-m (12 Nm, 8.6 lbf-ft)



16. BRAKE SYSTEM

Refer to the “**REAR PARKING SYSTEM**” section in this chapter to install the left master cylinder holder.

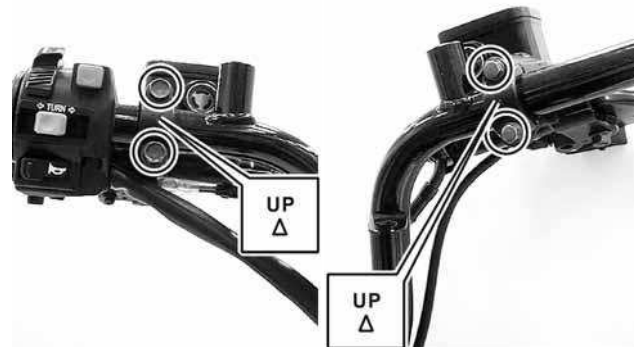

Install the brake fluid hose with the attaching bolt and two new sealing washers, then tighten the bolt to the specified torque.

Torque: 3.5 kgf-m (35 Nm, 25 lbf-ft)

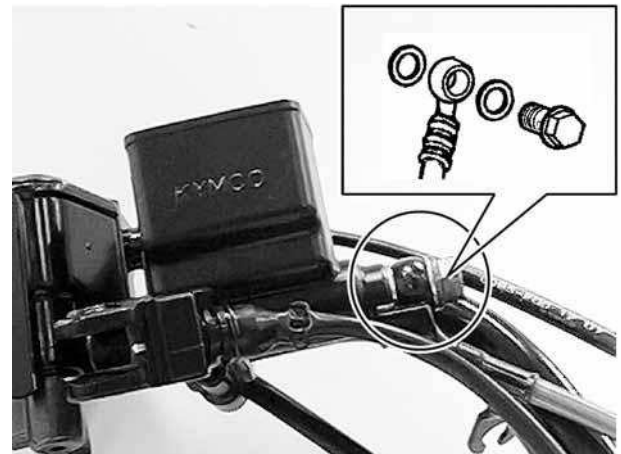

Apply lightweight lithium-soap base grease to the dust boot in the master cylinder, then install the brake lever.

Apply lightweight lithium-soap base grease to the bolt, then install and tighten the bolt and nut securely.

Fill the brake reservoir with the specified brake fluid and bleed air from the brake system (refer to the “**FRONT BRAKE FLUID CHANGE/AIR BLEED**” section or “**REAR BRAKE FLUID CHANGE/AIR BLEED**” section or “**COMBINATION BRAKE FLUID CHANGE/AIR BLEED**” section in this chapter).



Apply grease to the dust boot

Install the brake reservoir cap.

16. BRAKE SYSTEM

Brake pedal master cylinder

Install and tighten the two mounting bolts to the specified torque.

Torque: 1.2 kg-m (12 Nm, 8.6 lbf-ft)

Install the brake fluid hose (ON ROAD: two brake fluid hose) with the attaching bolt and two (ON ROAD: three) new sealing washers, then tighten the bolt to the specified torque.

Torque: 3.5 kgf-m (35 Nm, 25 lbf-ft)

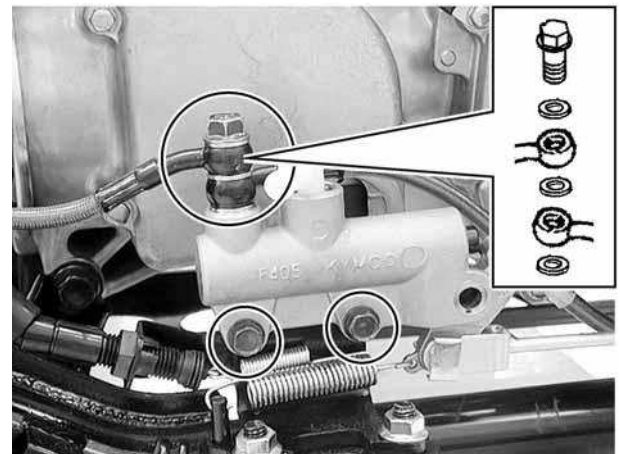

Apply lightweight lithium-soap base grease to the dust boot in the master cylinder, then install the brake arm.

Apply lightweight lithium-soap base grease to the bolt, then install and tighten the bolt and nut securely.

Connect the fluid hose to the master cylinder, then fix the joint.

Fill the brake reservoir with the specified brake fluid and bleed air from the brake system (refer to the “**COMBINATION BRAKE FLUID CHANGE/AIR BLEED**” section in this chapter).

Install the brake reservoir cap.

Apply grease to dust boot

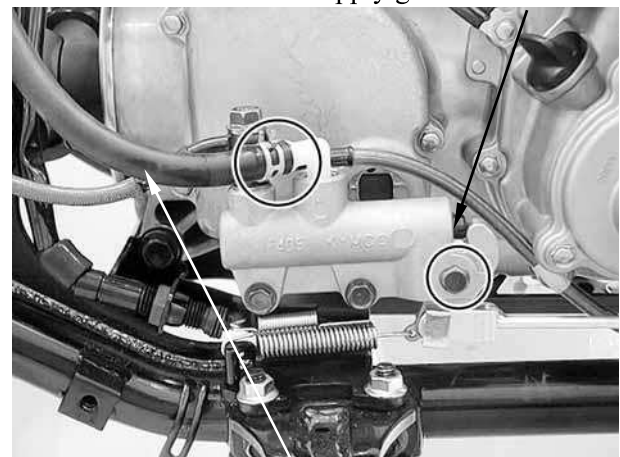

Fluid Hose

16. BRAKE SYSTEM

BRAKE MASTER CYLINDER DISASSEMBLY/INSPECTION/ ASSEMBLY

DISASSEMBLY

Front/rear brake master cylinder

Remove the brake master cylinder (refer to the “**BRAKE MASTER CYLINDERS REMOVAL/INSTALLATION**” section in this chapter).

Remove the piston dust boot and snap ring from the brake master cylinder.

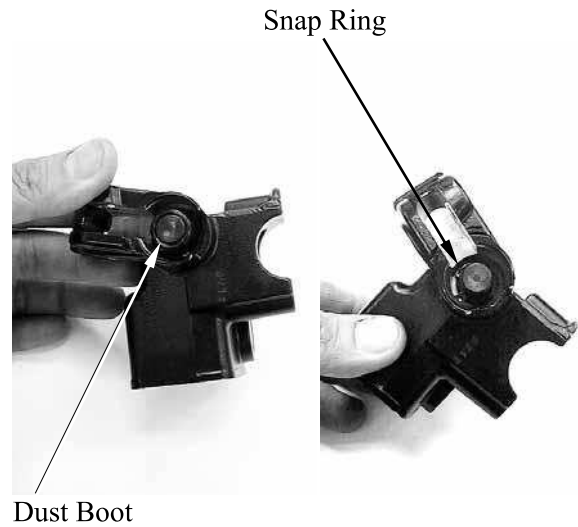

Remove the spring and piston together.

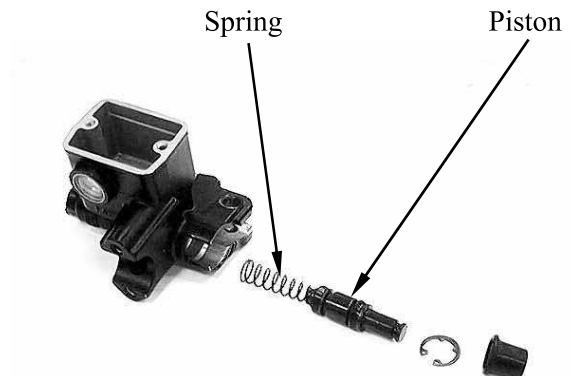

Brake pedal master cylinder

Remove the brake master cylinder (refer to the “**BRAKE MASTER CYLINDERS REMOVAL/INSTALLATION**” section in this chapter).

Remove the snap ring then remove the fluid duct and O-ring.

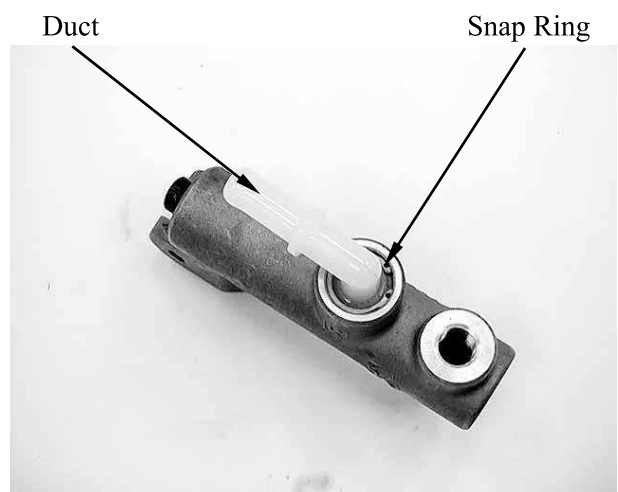

16. BRAKE SYSTEM

Remove the dust boot.
Remove the snap ring, then remove the piston and spring together.

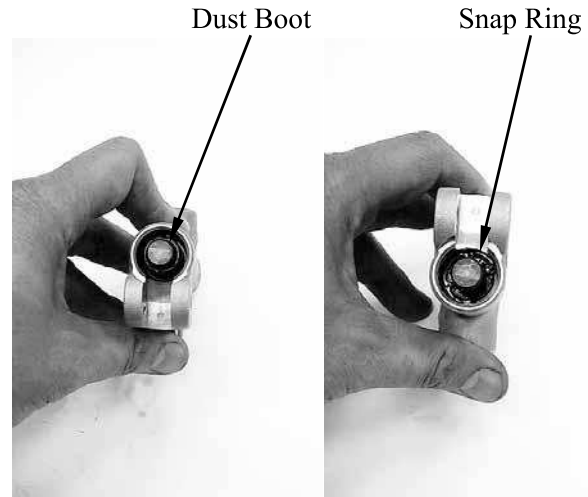

INSPECTION

Check the cylinder inside wall for scratch, corrosion or other abnormal condition.

If any abnormal condition is found, replace the master cylinder.

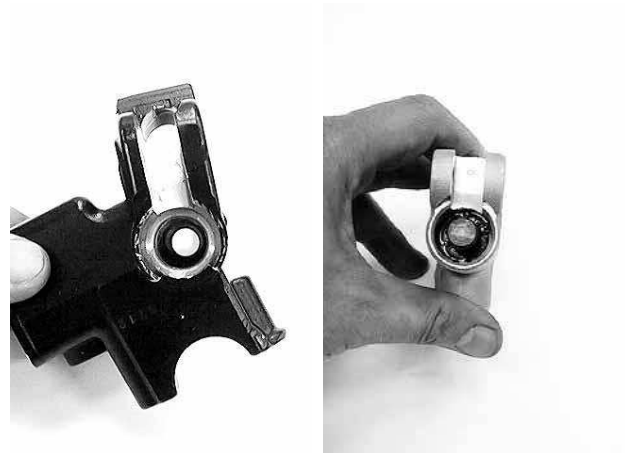

Check the spring and piston for scratch, corrosion or other abnormal condition.

If any abnormal condition is found, replace the parts.



ASSEMBLY

- Wash the master cylinder components with new brake fluid before reassembly.
- Do not wipe the brake fluid off with a rag after washing the components.
- When washing the components, use the specified brake fluid (DOT 4). Never use different types of fluid or cleaning solvents such as gasoline, kerosine, etc.
- Apply brake fluid to the master cylinder bore and all the component to be inserted to the bore.

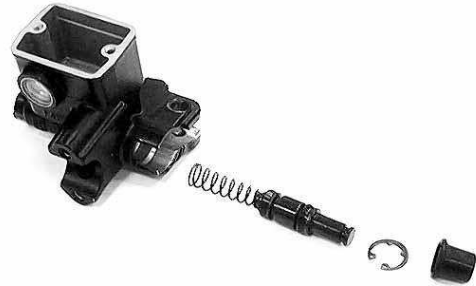

Front/rear brake master cylinder

Install the spring/piston.
Install the snap ring.
Install a new dust boot.

Brake pedal master cylinder

Install the spring/piston.
Install the snap ring.
Install a new dust boot.

Install a new O-ring.
Install the fluid duct.
Install the snap ring.

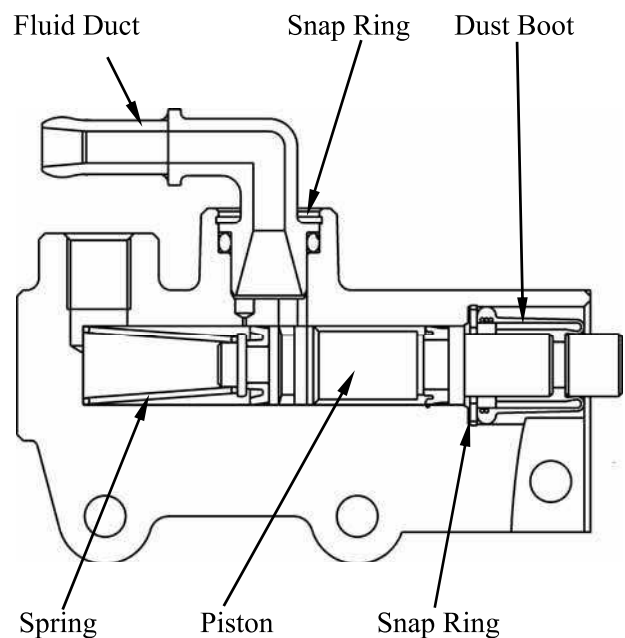

16. BRAKE SYSTEM

RELAY VALVE REMOVAL/DISASSEMBLY/INSPECTION/ASSEMBLY/ INSTALLATION (ON ROAD)

REMOVAL

Drain brake fluid (refer to the “**COMBINATION BRAKE FLUID CHANGE/AIR BLEED (ON ROAD)**” section in this chapter).

Do not splash brake fluid onto any rubber, plastic and coated parts. When working with brake fluid, use shop towels to cover these parts.

Remove all fluid hoses bolts/washers and then disconnect the all fluid hoses.

When removing the brake fluid hose bolt, be sure to place towels under the hose and plug the hose end to avoid brake fluid leakage and contamination.

Remove the two mounting bolts and remove the relay valve.



DISASSEMBLY

Remove the bolt.

Remove the spring.

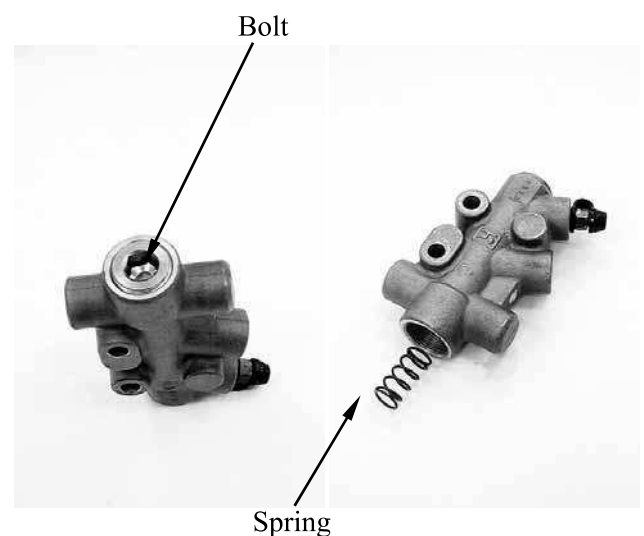

16. BRAKE SYSTEM

Push the piston out with a screwdriver.

INSPECTION

Check the delay valve body inside wall for scratch, corrosion or other abnormal condition.

If any abnormal condition is found, replace the delay valve.

Check the spring and piston for scratch, corrosion or other abnormal condition.

If any abnormal condition is found, replace the parts.

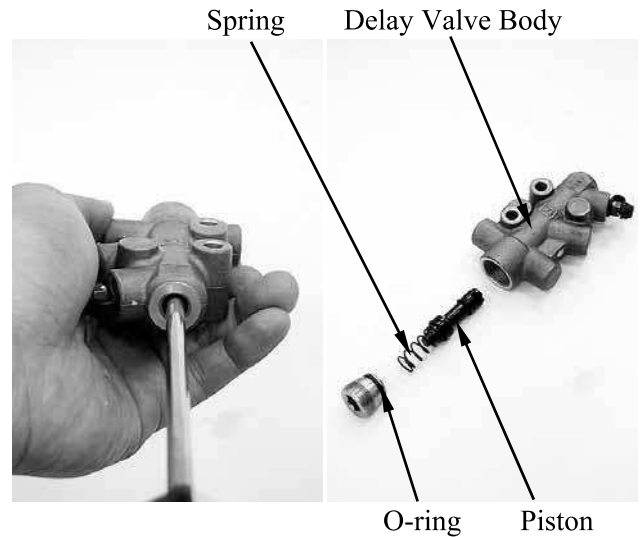

ASSEMBLY

- Wash the delay valve components with new brake fluid before reassembly.
- Do not wipe the brake fluid off with a rag after washing the components.
- When washing the components, use the specified brake fluid (DOT 4). Never use different types of fluid or cleaning solvents such as gasoline, kerosine, etc.
- Apply brake fluid to the delay valve bore and all the component to be inserted to be inserted to the bore.

Install the piston.

Install the spring.

Replace a new O-ring then install and tighten the bolt to the specified torque.

Torque: 5 kgf-m (50 N-m, 36 lbf-ft)

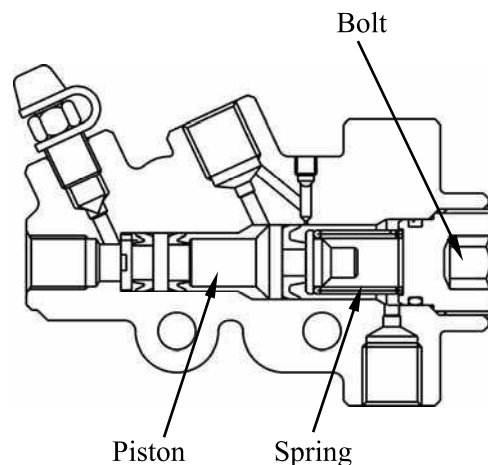

16. BRAKE SYSTEM

INSTALLATION

Install and tighten the mounting bolts to the specified torque.

Torque: 1.2 kgf-m (12 Nm, 8.6 lbf-ft)

Install the all brake fluid hoses with the attaching bolts and new sealing washers, then tighten the bolts to the specified torque.

Torque: 3.5 kgf-m (35 Nm, 25 lbf-ft)

Fill the specified brake fluid and bleed air from the brake system (refer to the **“COMBINATION BRAKE FLUID CHANGE/AIR BLEED”** section in this chapter).

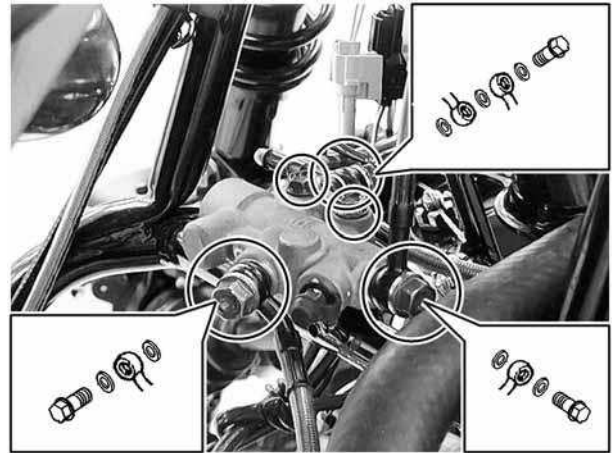

16. BRAKE SYSTEM

FRONT BRAKE CALIPERS REMOVAL/INSTALLATION

REMOVAL

Drain the brake fluid from the hydraulic brake system (refer to the “**FRONT BRAKE FLUID CHANGE/AIR BLEED (OFF ROAD)**” section or “**COMBINATION BRAKE FLUID CHANGE/AIR BLEED (ON ROAD)**” section in this chapter).

Remove the brake fluid hose bolt and two washers from the caliper.

Remove the brake pads (refer to the “**BRAKE PADS REPLACEMENT**” section in this chapter).

Remove the brake caliper.

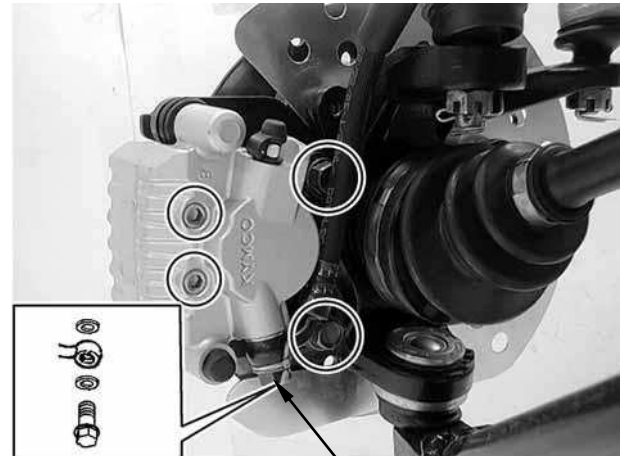

Fluid Hose Bolt/Washers

INSTALLATION

Install the brake fluid hose with the attaching bolt and two new sealing washers, then tighten the bolt to the specified torque.

Torque: 3.5 kgf-m (35 Nm, 25 lbf-ft)

Fill the specified brake fluid and bleed air from the brake system (refer to the “**FRONT BRAKE FLUID CHANGE/AIR BLEED**” section or “**COMBINATION BRAKE FLUID CHANGE/AIR BLEED**” section in this chapter).

16. BRAKE SYSTEM

REAR BRAKE CALIPERS REMOVAL/INSTALLATION

Drain the brake fluid from the hydraulic brake system (refer to the “**REAR BRAKE FLUID CHANGE/AIR BLEED**” section in this chapter).

Remove the brake fluid hose bolt and two washers from the caliper.

Remove the brake pads (refer to the “**BRAKE PADS REPLACEMENT**” section in this chapter).

Remove the brake caliper.



INSTALLATION

Install the brake fluid hose with the attaching bolt and two new sealing washers, then tighten the bolt to the specified torque.

Torque: 3.5 kgf-m (35 Nm, 25 lbf-ft)

Fill the specified brake fluid and bleed air from the brake system (refer to the “**REAR BRAKE FLUID CHANGE/AIR BLEED**” section in this chapter).



16. BRAKE SYSTEM

REAR BRAKE/PARKING BRAKE CALIPER REMOVAL/INSTALLATION

Drain the brake fluid from the hydraulic brake system (refer to the “**COMBINATION BRAKE FLUID CHANGE/AIR BLEED**” section in this chapter).

Disconnect the parking brake cable from the caliper.

Remove the brake fluid hose bolt and two washers from the caliper.

Remove the brake pads (refer to the “**BRAKE PADS REPLACEMENT**” section in this chapter).

Remove the brake caliper.

INSTALLATION

Install the brake fluid hose with the attaching bolt and two new sealing washers, then tighten the bolt to the specified torque.

Torque: 3.5 kgf-m (35 Nm, 25 lbf-ft)

Connect the parking brake cable.

Fill the specified brake fluid and bleed air from the brake system (refer to the “**COMBINATION BRAKE FLUID CHANGE/AIR BLEED**” section in this chapter).

Adjust the parking brake lever (refer to the “**PARKING BRAKE ADJUSTMENT**” section in the chapter 3).

Parking Brake Cable

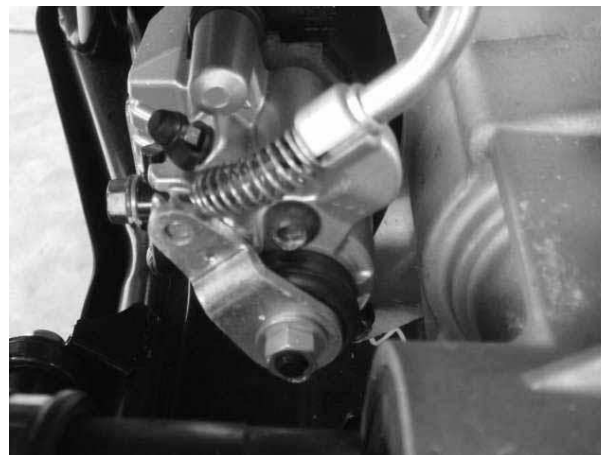
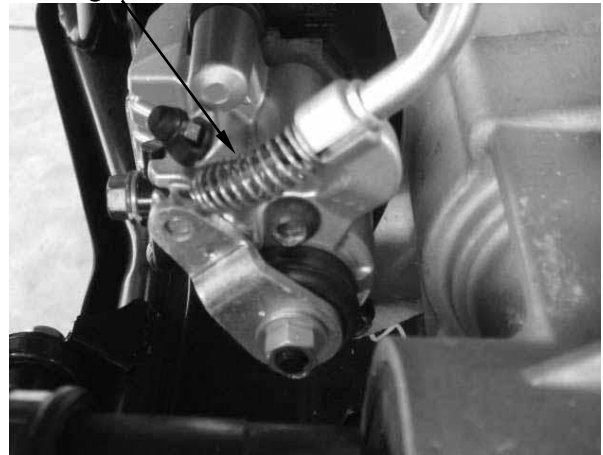

16. BRAKE SYSTEM

BRAKE CALIPER DISASSEMBLY/INSPECTION/ ASSEMBLY

DISASSEMBLY

Remove the front or rear brake caliper (refer to the “**FRONT BRAKE CALIPERS REMOVAL/INSTALLATION**” section or “**REAR BRAKE CALIPERS REMOVAL/INSTALLATION**” section in this chapter).

Remove the brake pad spring plate.

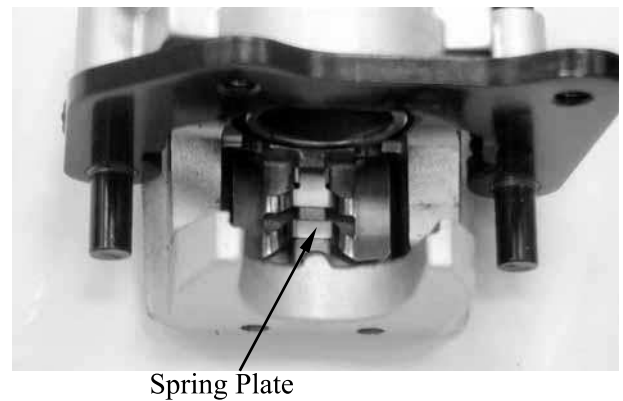

Remove the piston from the brake caliper. If necessary, use compressed air to squeeze out the piston through the brake fluid inlet opening and place a shop towel under the caliper to avoid contamination caused by the removed piston.



16. BRAKE SYSTEM

Push the piston dust seal inward to remove.

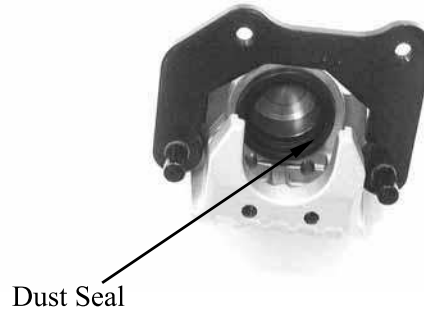

Pushing the piston oil seal outward to remove it.

Clean the seals groove with brake fluid.

Be careful not to damage the piston surface.

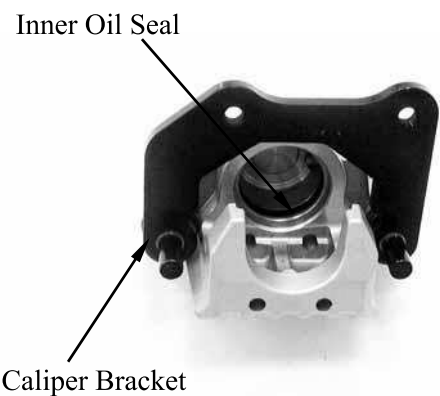

Remove the caliper bracket.

INSPECTION

Inspect the caliper cylinder wall and piston surface for scratch, corrosion or other damages.

If any abnormal condition is noted, replace the caliper.

Inspect the dust boots for deterioration or damage.

If any damages are found, replace them with a new ones.



ASSEMBLY

- Wash the brake caliper components with new brake fluid before reassembly.
- Do not wipe the brake fluid off with a rag after washing the components.
- When washing the components, use the specified brake fluid (DOT 4). Never use different types of fluid or cleaning solvents such as gasoline, kerosine, etc.
- Apply brake fluid to all of the seals, brake caliper bore and piston before reassembly.



Apply silicone grease to the caliper bracket pins.

16. BRAKE SYSTEM

REAR BRAKE/PARKING BRAKE CALIPER DISASSEMBLY/INSPECTION/ ASSEMBLY

DISASSEMBLY/INSPECTION

Remove parking brake caliper (refer to the “**REAR BRAKE/PARKING BRAKE CALIPER EMOVAL/INSTALLATION**” section in this chapter).

Remove the brake pad spring plate.

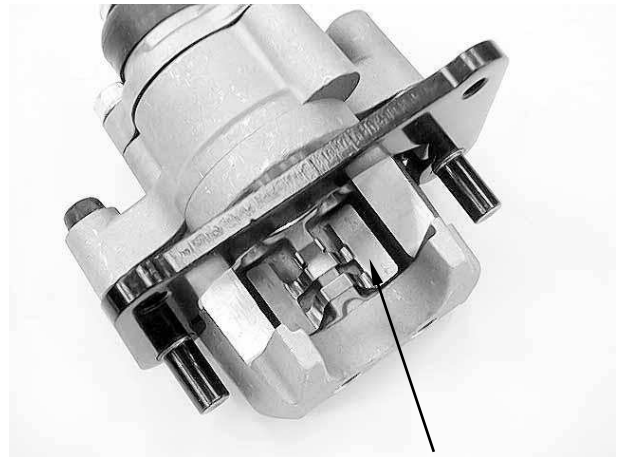

Spring Plate

Remove the piston from the brake caliper. If necessary, use compressed air to squeeze out the piston through the brake fluid inlet opening and place a shop towel under the caliper to avoid contamination caused by the removed piston.

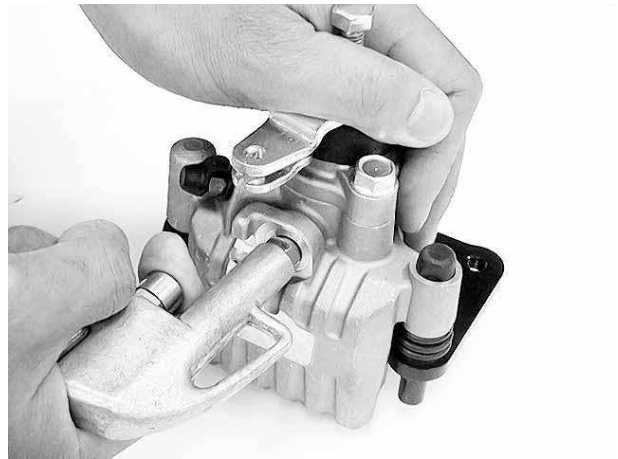

Inspect the caliper cylinder wall and piston surface for scratch, corrosion or other damages. If any abnormal condition is noted, replace the caliper.

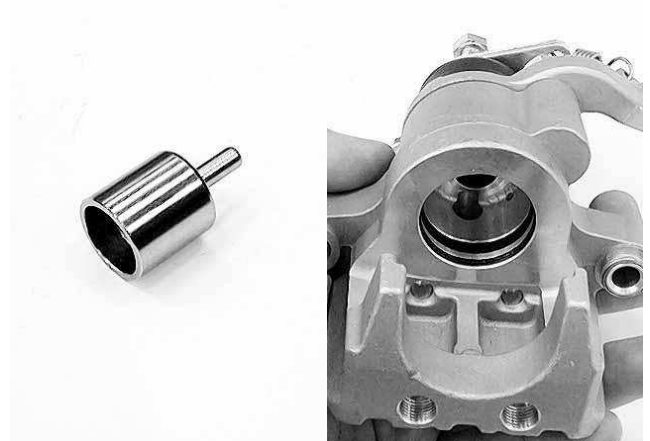

16. BRAKE SYSTEM

Inspect the dust boots for deterioration or damage.
If any damages are found, replace them with a new ones.

Remove the caliper bracket.
Remove the dust boot.

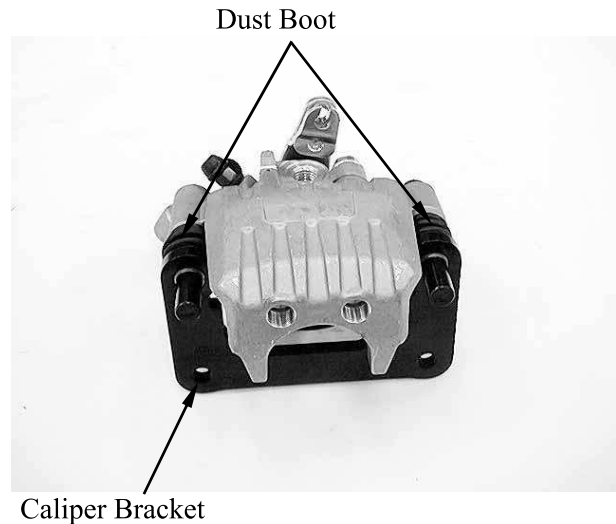

Remove the dust seal and piston seal.

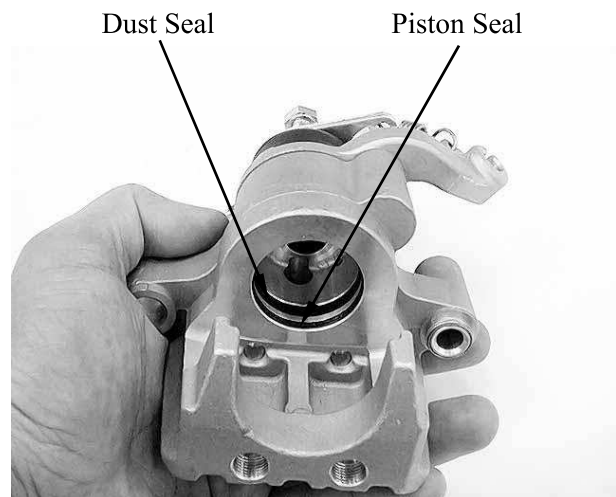

Loosen the lock nut while hold the adjusting bolt.
Remove the adjusting bolt.
Remove the parking brake arm and spring.

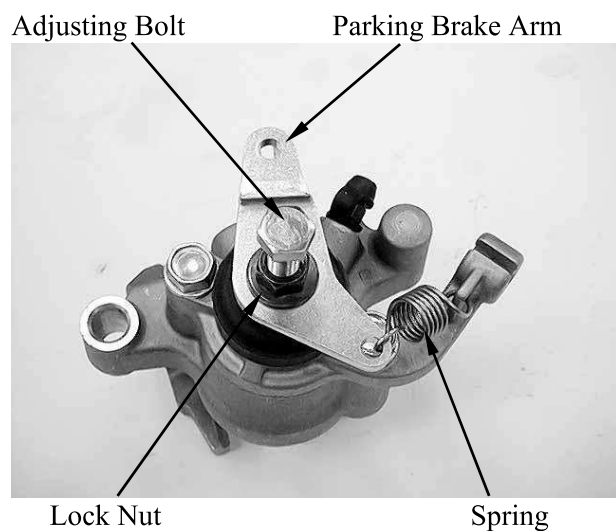

16. BRAKE SYSTEM

Inspect the dust boot for deterioration or damage.

If any damage is found, replace it with a new one.

Remove the drive bolt and dust boot.

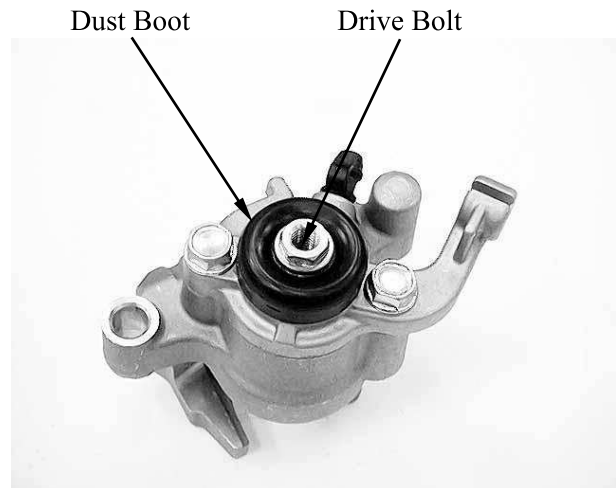

Inspect the drive shaft and shaft guide for wear or damage.

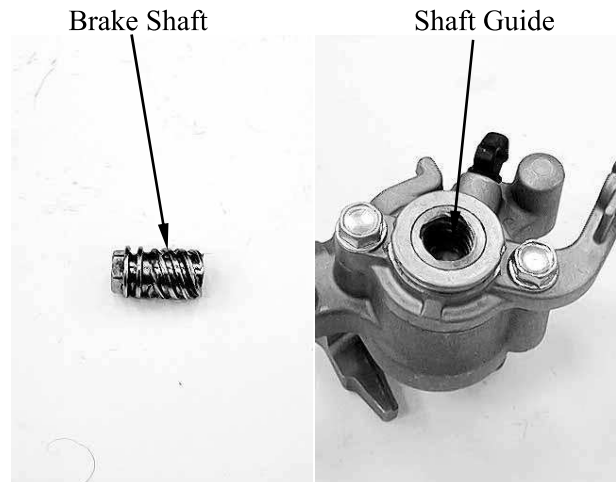

Remove the two bolts and parking brake case.



16. BRAKE SYSTEM

Remove the O-ring.

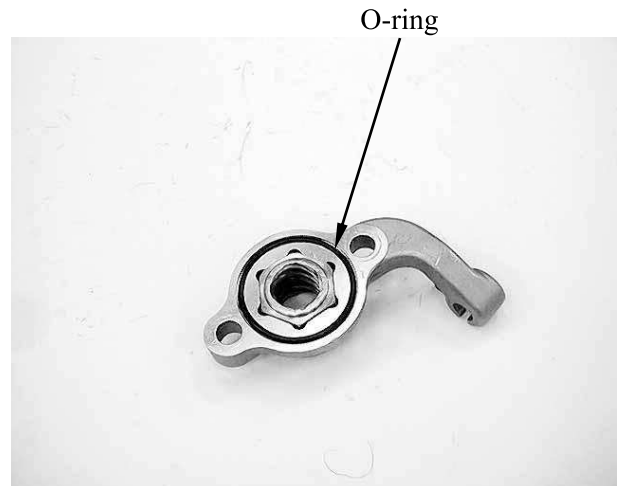

Inspect the O-ring for wear or damage.
If any damages are found, replace it with a new one.

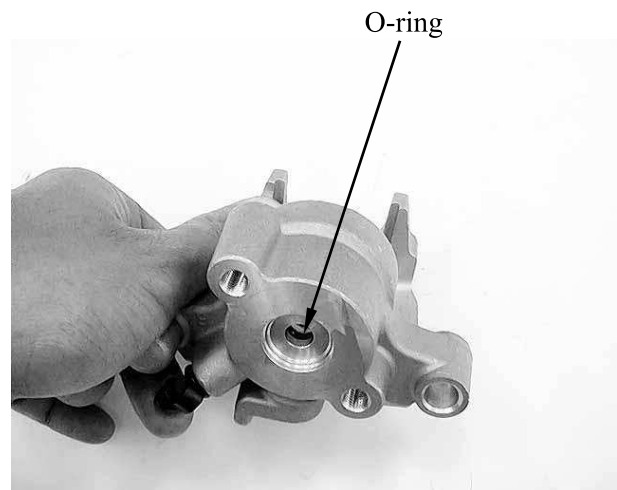

INSTALLATION

Apply silicone grease to the new O-ring, then install the new O-ring.

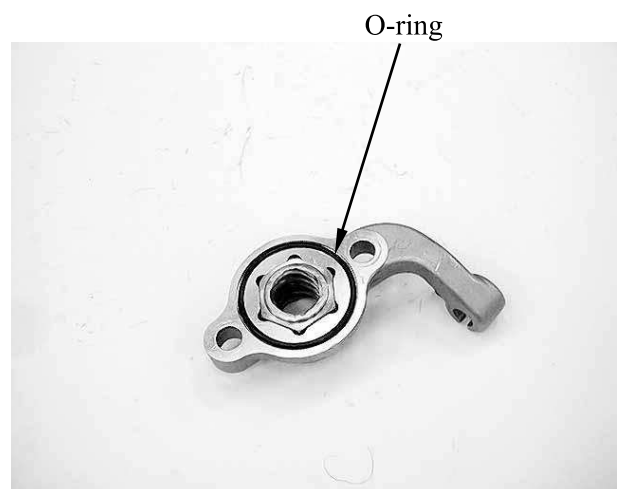

16. BRAKE SYSTEM

Install the parking brake case and two bolts.
Tighten the bolts securely.

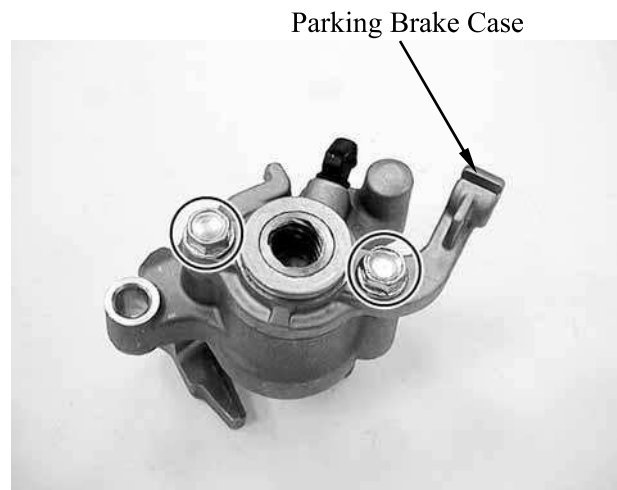

Apply silicone grease to the new piston seal
and new dust seal, then install them.

Install the piston.

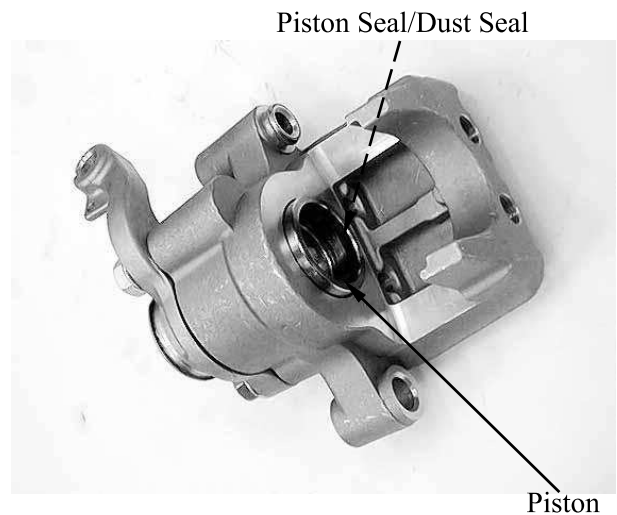

Apply silicone grease to the brake shaft, then
install it.

Apply silicone grease to the dust boot, then
install it.

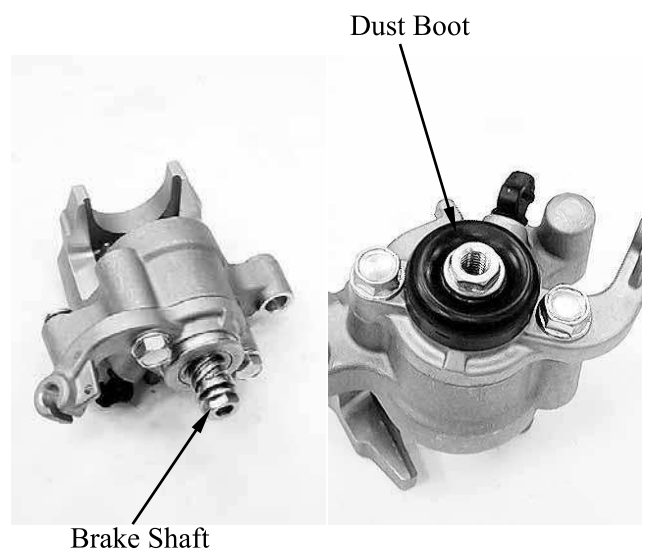

16. BRAKE SYSTEM

Press the piston and turn the brake shaft counterclockwise to expand boot, then the brake shaft does not touch piston.

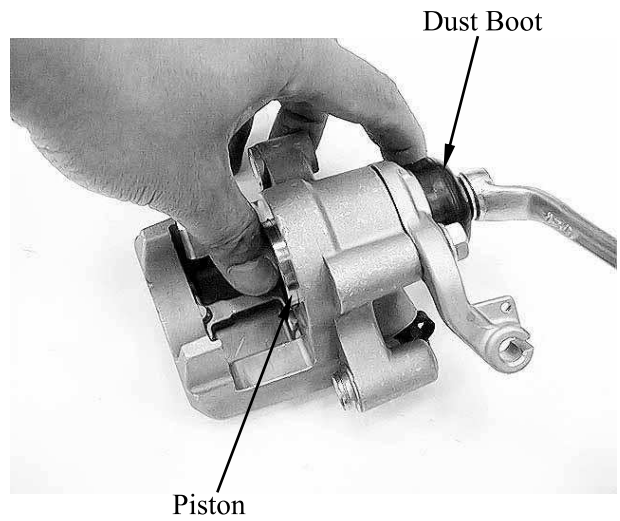

Install the parking brake arm and spring.

Align the parking brake arm with the brake fluid inlet hole as shown.

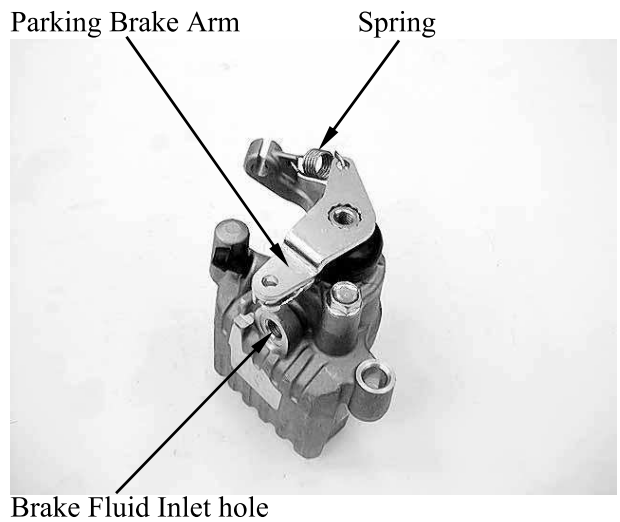

Install the adjusting bolt and lock nut.

Do not turn in the adjusting too much and do not tighten the lock nut.

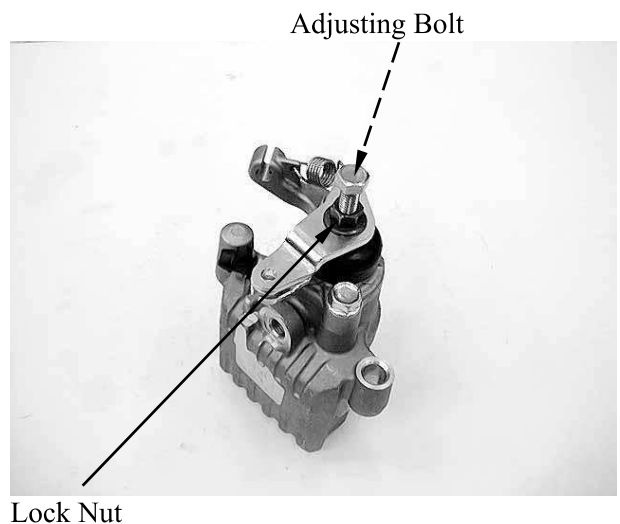

16. BRAKE SYSTEM

Install the dust boots.

Apply silicone grease to caliper bracket, then install it.

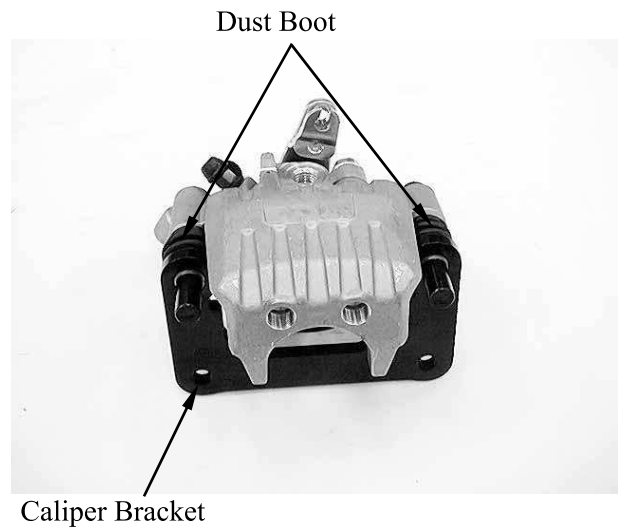

Install the spring plate.

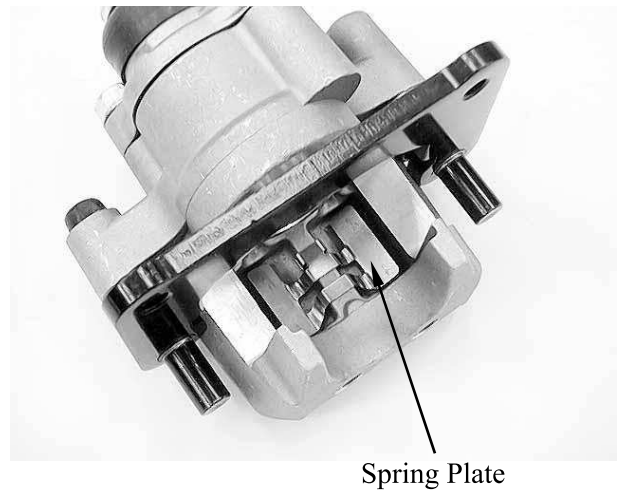

Install the parking brake caliper (refer to the **“REAR BRAKE/PARKING BRAKE CALIPER REMOVAL/INSTALLATION”** section in this chapter).

Adjust the parking brake (refer to the **“PARKING BRAKE ADJUSTMENT”** section in the chapter 3).

17. BATTERY/CHARGING SYSTEM

17

BATTERY/CHARGING SYSTEM

| | |
|---|-------|
| CHARGING SYSTEM LAYOUT/CHARGING CIRCUIT ----- | 17- 1 |
| SERVICE INFORMATION----- | 17- 2 |
| TROUBLESHOOTING----- | 17- 4 |
| BATTERY ----- | 17- 5 |
| CHARGING SYSTEM INSPECTION ----- | 17- 6 |
| ALTERNATOR CHARGING COIL----- | 17- 7 |
| REGULATOR/RECTIFIER----- | 17- 8 |
| ALTERNATOR STATOR REMOVAL/INSPECTION/ INSTALLATION ----- | 17-11 |

17. BATTERY/CHARGING SYSTEM

CHARGING SYSTEM LAYOUT

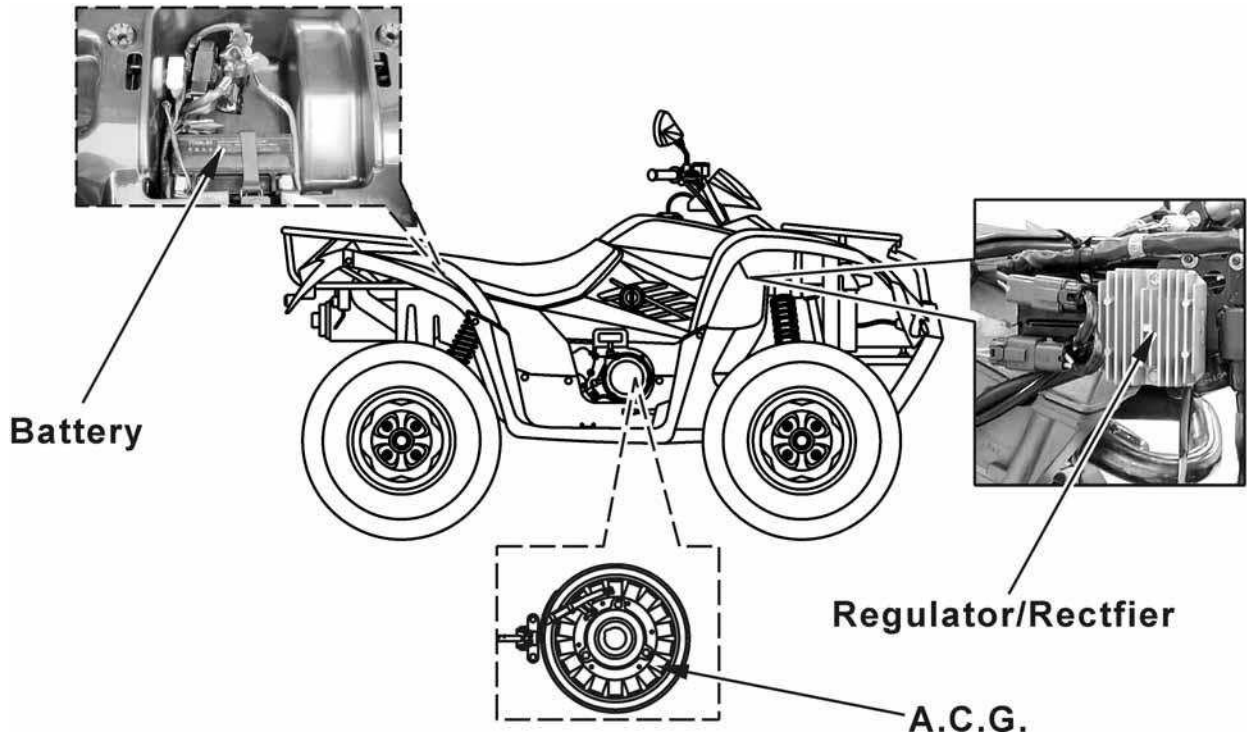

CHARGING CIRCUIT

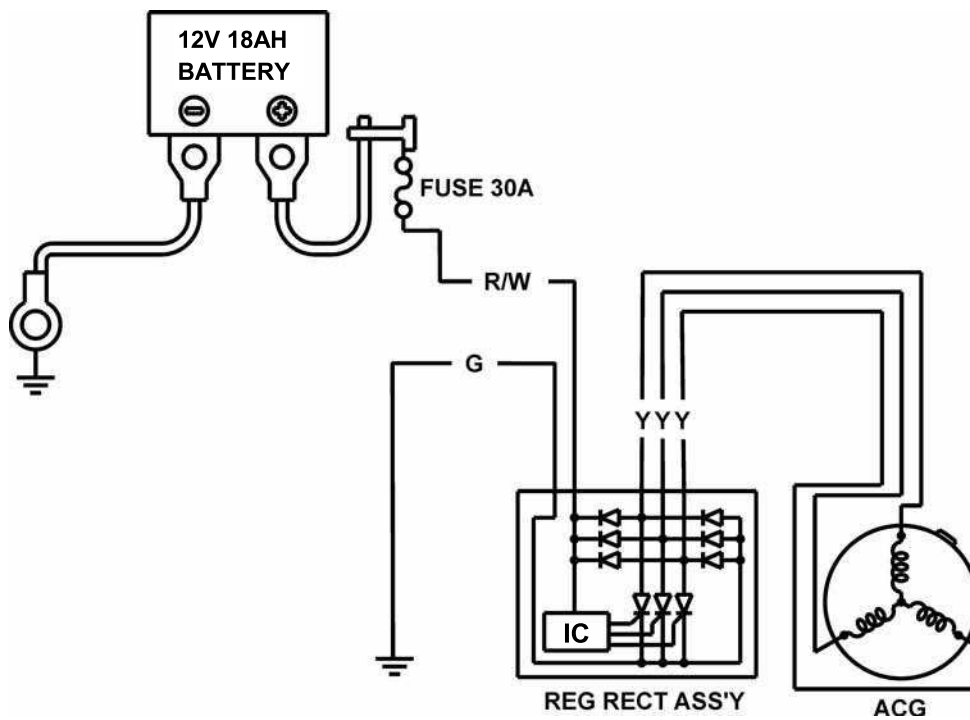

17. BATTERY/CHARGING SYSTEM

SERVICE INFORMATION

GENERAL

CAUTION

- The battery gives off explosive gases; keep sparks, flames and cigarettes away. Provide adequate ventilation when charging.
- The battery contains sulfuric acid (electrolyte). Contact with skin or eyes may cause severe burns. Wear protective clothing and a face shield.
 - If electrolyte gets on your skin, flush with water.
 - If electrolyte gets in your eyes, flush with water for at least 15 minutes and call a physician immediately.
- Electrolyte is poisonous.
 - If swallowed, drink large quantities of water or milk and call your local Poison Control Center or physician immediately, **KEEP OUT OF REACH OF CHILDREN.**

- Always turn off the ignition switch before disconnecting any electrical component.
- Some electrical components may be damaged if terminals or connectors are connected or disconnected while the ignition switch is turned to “ON” and current is present.
- For extended storage, remove the battery, give it a full charge, and store it in a cool, dry place.
- For a battery remaining in a shorted vehicle, disconnect the negative battery cable from the battery.
- The battery caps should not be removed. Attempting to remove the sealing caps from the cells may damage the battery.
- The maintenance free battery must be replaced when it reaches the end of its service life.
- The battery can be damaged if overcharged or undercharged, or if left to discharge for long period. These same conditions contribute to shortening the “life span” of the battery. Even under normal use, the performance of the battery deteriorates after 2-3 years.
- Battery voltage may recover after battery charging, but under heavy load, the battery voltage will drop quickly and eventually die out. For this reason, the charging system is often suspected as the problem. Battery overcharge often results from problems in the battery itself, which may appear to be an overcharging symptom. If one of the battery cells is shorted and battery voltage does not increase, the regulator/rectifier supplies excess voltage to the battery. Under these conditions, the electrolyte level goes down quickly.
- Before troubleshooting the charging system, check for proper use and maintenance of the battery. Check if the battery is frequently under heavy load, such as having the headlight and taillight on for long periods of time without riding the vehicle.
- The battery self-discharge when the vehicle is not in use, for this reason, charge the battery every 2 weeks to prevent sulfate from occurring.
- Filling a new battery with electrolyte will produce some voltage, but in order to achieve its maximum performance, always charge the battery. Also, the battery life is lengthened when it is initially charged.
- When checking the charging system, always follow the steps in the troubleshooting flow chart (page 17-4)

17. BATTERY/CHARGING SYSTEM

BATTERY CHARGING

- This model comes with a maintenance free (MF) battery. Remember the following about MF batteries.
 - Use only the electrolyte that comes with the battery.
 - Use all of the electrolyte
 - Seal the battery properly
 - Never open the seals again
- For battery charging, do not exceed the charging current and time specified on the battery. Using excessive current or extending the charging time may damage the battery.

SPECIFICATIONS

| ITEM | | SPECIFICATIONS | |
|------------|--------------------------------------|----------------------|----------------|
| Battery | Capacity | 12V – 18 Ah | |
| | Current leakage | 0.5 Ma max. | |
| | Voltage (20°C/68°F) | Full charged | 13.0 – 13.2 V |
| | | Needs charging | Below 12.3 V |
| | Charging current | Normal | 1.8 A/5 – 10 h |
| Quick | | 9 A/1 h | |
| Alternator | Capacity | 310 – 400 W/5000 rpm | |
| | Charging coil resistance (20°C/68°F) | 0.1 – 0.3 Ω | |

17. BATTERY/CHARGING SYSTEM

TROUBLESHOOTING

Battery is damaged or weak

Remove the battery.
Check the battery condition.

Correct



Install the battery.
Check the battery current leakage.

Specified current leakage: 0.5 Ma max

Correct



Check the alternator charging coil.

Standard: 0.1 – 0.3 Ω (20°C/68°F)

Correct



Measure and record the battery voltage using a digital multimeter.
Start the engine.
Measure the charging voltage.
Compare the measurements to result of the following calculation.

Measured voltage < measured charging voltage < 15.5 V

Incorrect



Perform the regulator/rectifier wire harness inspection.

Correct



•Faulty regulator/rectifier

— Incorrect —> •Faulty battery

— Incorrect —> Disconnect the regulator/rectifier connectors and recheck the battery current leakage.

Incorrect

Correct

•Faulty regulator/rectifier.

•Shorted wire harness.

•Faulty ignition switch.

— Incorrect —> •Faulty charging coil.

— Correct —> •Faulty battery.

— Incorrect —> •Open circuit in related wire.
•Loose or poor contacts of related terminal.
•Shorted wire harness

17. BATTERY/CHARGING SYSTEM

BATTERY

REMOVAL/INSTALLATION

Battery removal

1. Make sure the ignition switch is OFF.
2. Remove the seat (refer to the “**FRAME COVERS**” section in the chapter 2)
3. Release the rings and remove the rubber band (1).
4. Disconnect the negative (-) terminal lead (2) from the battery first, then disconnect the positive (+) terminal lead (3).
5. Remove the battery.

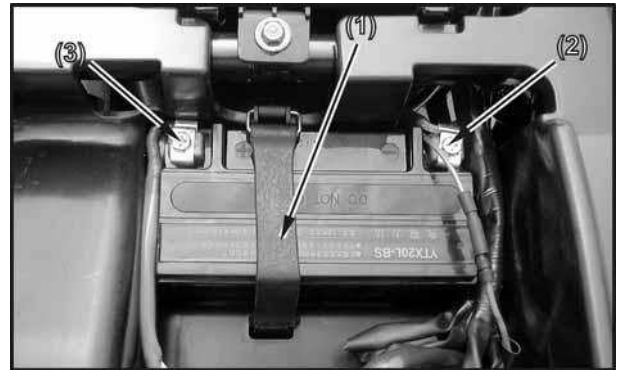

Battery installation

1. Install in the reverse order of removal.
2. After installing the battery, check to see if the battery cables are routed correctly.

After connecting the battery cables, coat the terminals with grease.

VOLTAGE INSPECTION

Remove the battery cover (see above).

Measure the battery voltage using a commercially available digital multi-meter.

Voltage (20°C/68°C):

Fully charged: 13.0 13.2 V

Under charged: below 12.3 V



17. BATTERY/CHARGING SYSTEM

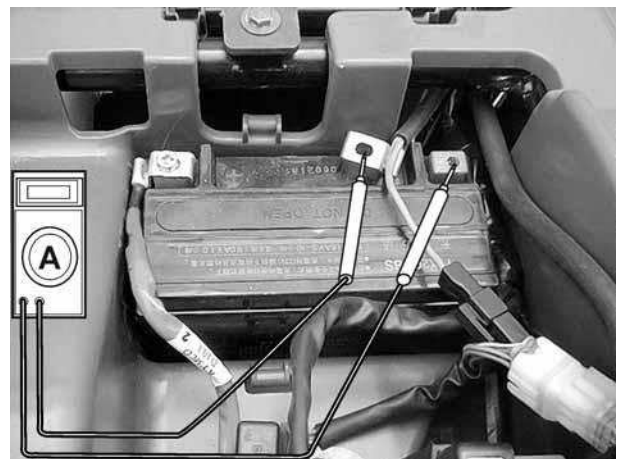
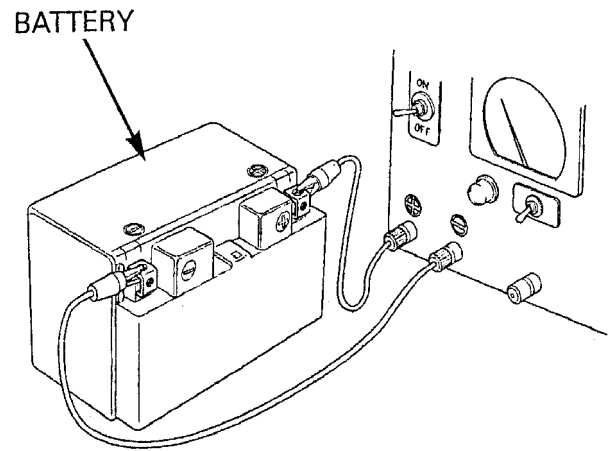

17. BATTERY/CHARGING SYSTEM

CHARGING VOLTAGE INSPECTION

Be sure that the battery is in good condition before performing this test.

Do not disconnect the battery or any cable in the charging system without first switching off the ignition system. Failure to follow this precaution can damage the tester or electrical components.

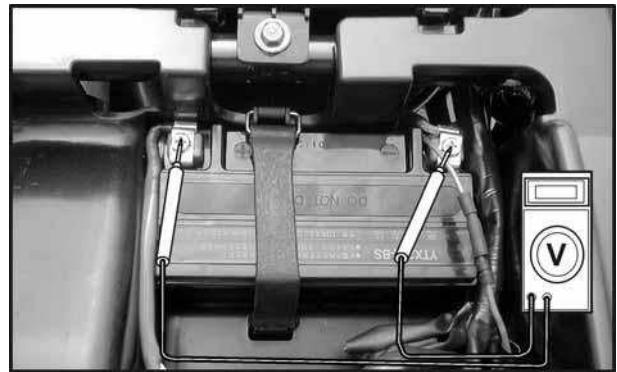

Start the engine and warm it up to the operating temperature; stop the engine. Connect the multi-meter between the positive and negative terminals of the battery.

To prevent short, make absolutely certain which are the positive and negative terminals or cable.

With the headlight on and turned to the high beam position, restart the engine.

Measure the voltage on the multi-meter when the engine runs at 5000 min-1 (rpm).

Standard:

Measured battery voltage (page 17-5) <

Measure charging voltage (see above) <

15 V

ALTERNATOR CHARGING COIL

INSPECTION

Disconnect the alternator connector.

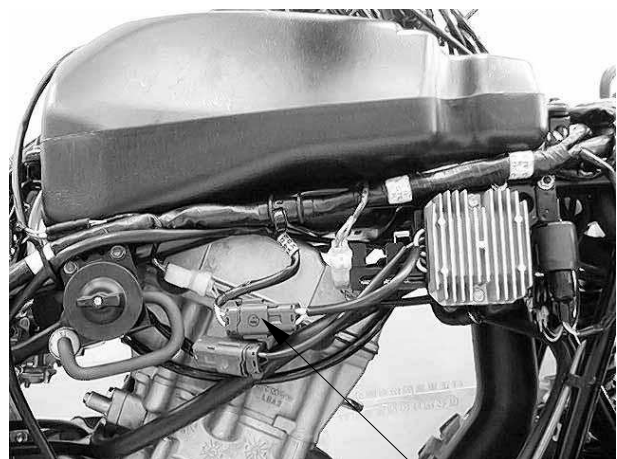

Alternator Connector

17. BATTERY/CHARGING SYSTEM

Measure the resistance between each Yellow wire terminals.

Standard: 0.1 – 0.3 Ω (20°C/68°F)

Check for continuity between each Yellow wire terminal of the alternator side connector and ground.

There should be no continuity.

Replace the alternator stator if resistance is out of specification, or if any wire has continuity to ground.

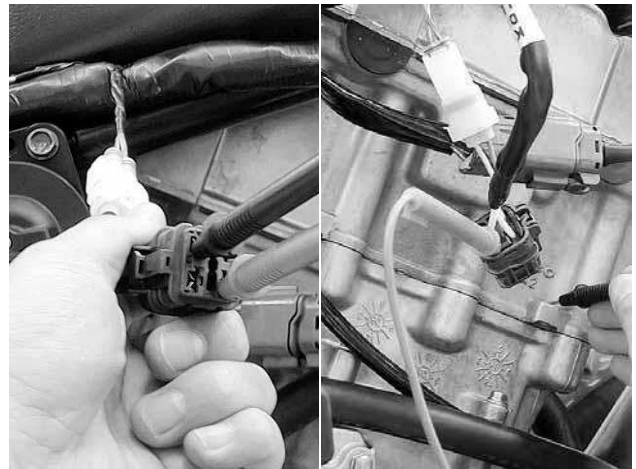

REGULATOR/RECTIFIER

WIRE HARNESS INSPECTION

Disconnect the regulator/rectifier connectors. Check the connectors for loose contacts of corroded terminals.

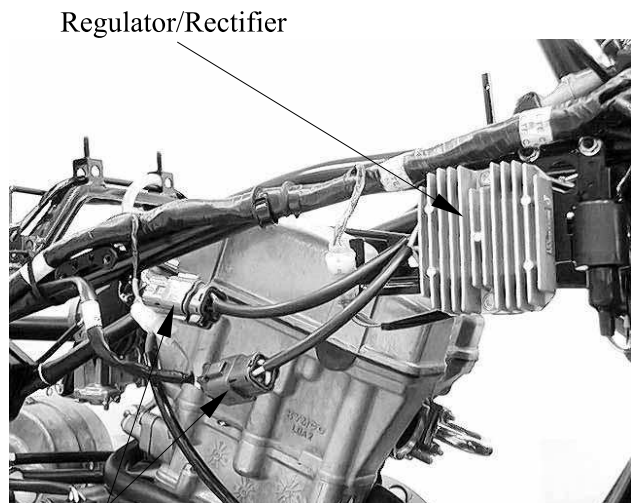

Battery line

Measure the voltage between the Red/White wire terminal and ground.

There should be battery voltage at all times.

Voltage feedback line

Measure the voltage between the black wire terminal and ground.

There should be battery voltage with the ignition switch “ON”, and no voltage with the ignition switch “OFF”.



17. BATTERY/CHARGING SYSTEM

Ground line

Check the continuity between the Green wire terminal and ground.

There should be continuity at all times.

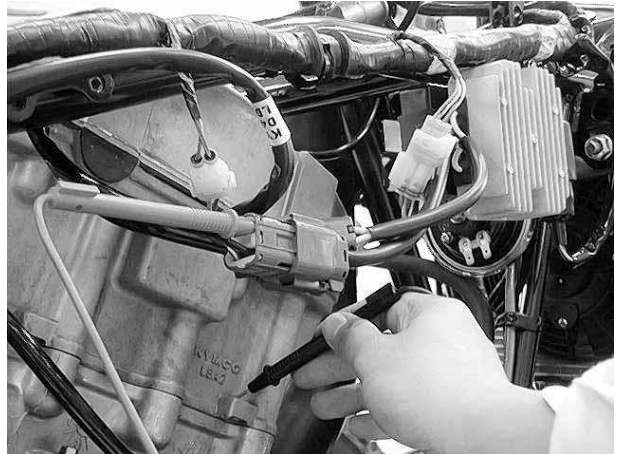

Charging coil line

Measure the resistance between each Yellow wire terminals.

Standard: 0.1 – 0.3 Ω (20°C/68°F)

Check for continuity between each Yellow wire terminal and ground.

There should be no continuity.



17. BATTERY/CHARGING SYSTEM

REMOVAL/INSTALLATION

Disconnect the regulator/rectifier connectors.

Remove the two bolts and then remove the regulator/rectifier.

Installation is in the reverse order of removal.

Regulator/Rectifier Connector

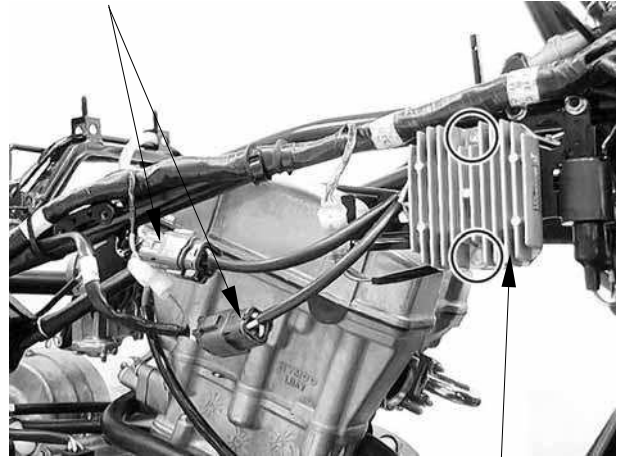

Regulator/Rectifier

17. BATTERY/CHARGING SYSTEM

ALTERNATOR STATOR REMOVAL/INSPECTION/ INSTALLATION

REMOVAL

Drain the engine oil (refer to the “ENGINE OIL” section in the chapter 3).

Disconnect the alternator stator connectors.



Alternator Stator Connectors

Remove the starter pulley (refer to the “STARTER PULLEY REMOVAL/INSPECTION/INSTALLATION” section in the chapter 19).

Remove the oil filler plug.

Oil Filler Plug

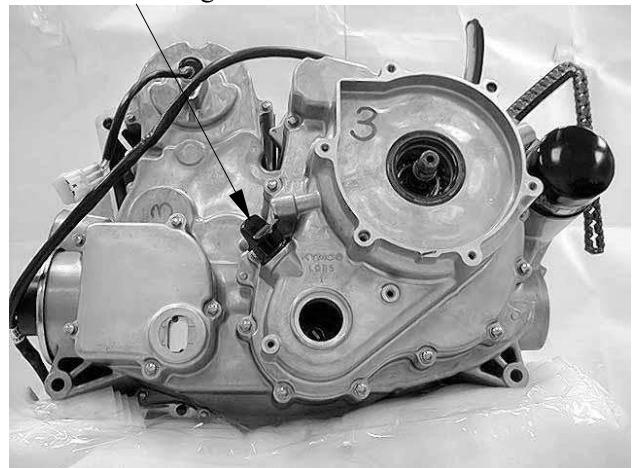

Remove the fourteen bolts and then remove the right crankcase cover.

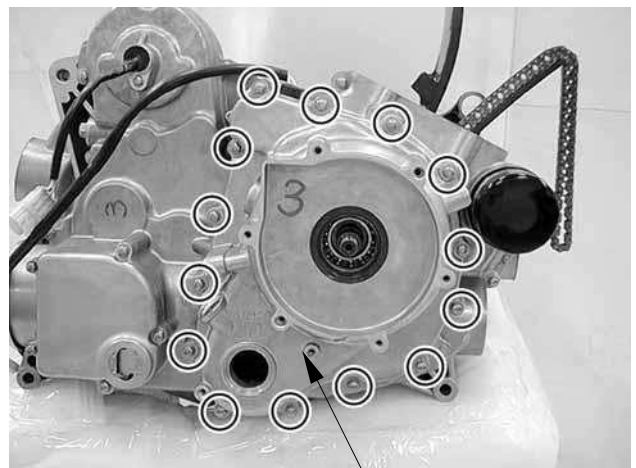

Right Crankcase Cover

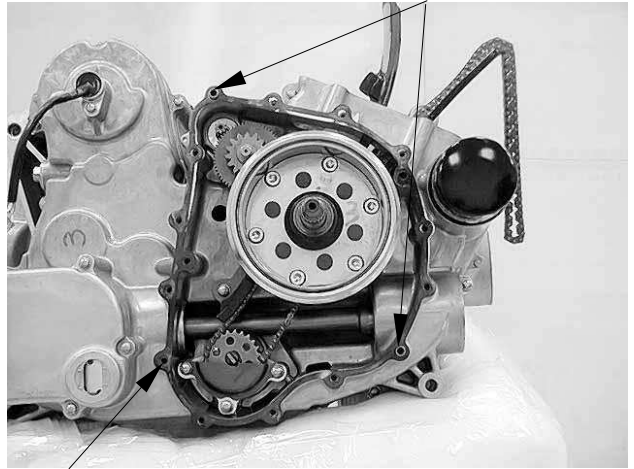

t

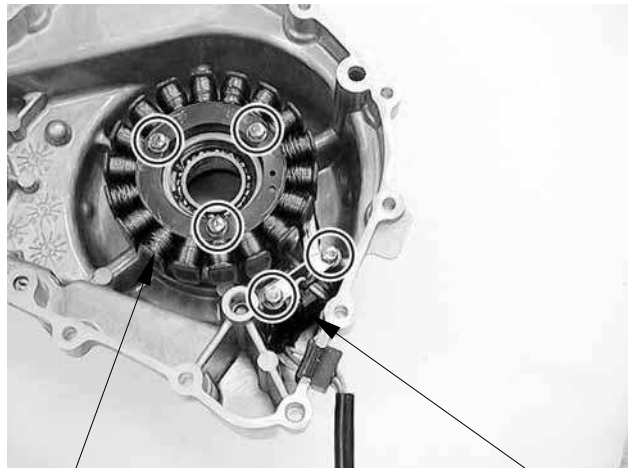

Stator

Pulse Coil

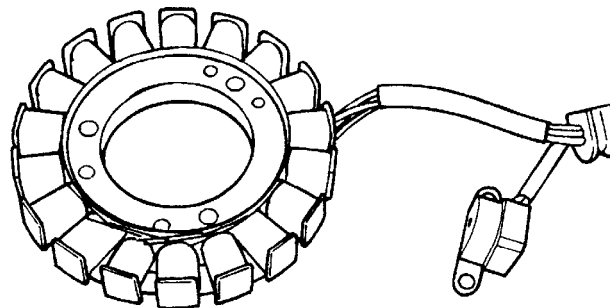

17. BATTERY/CHARGING SYSTEM

INSTALLATION

Install the stator and tighten the stator mount bolts to the specified torque.

Torque: 1.2 kgf-m (12 N-m)

Apply sealant to the grommet seating surface and install it to the cover groove properly.

Install the pulse coil and tighten mount bolts to the specified torque.

Torque: 1.2 kgf-m (12 N-m)

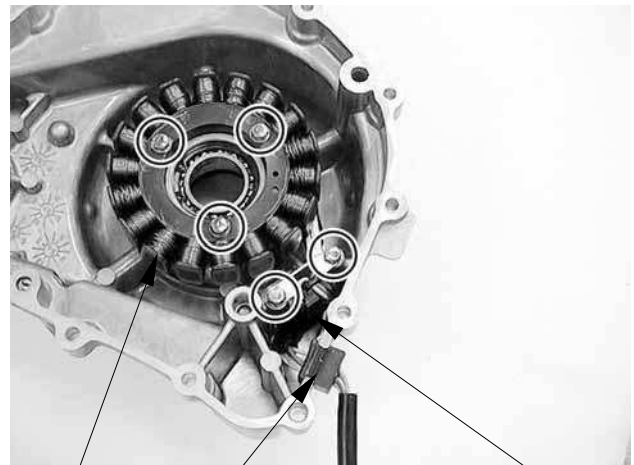

Stator Grommet Pulse

Clean the mating surfaces of the right crankcase and cover.

Install the dowel pins and gasket.

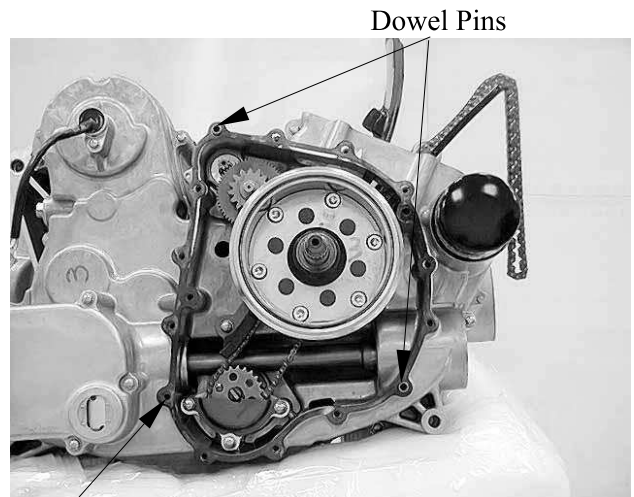

Gasket

Install the right crankcase cover and tighten the bolts in a crisscross pattern in 2 or 3 steps.

FLYWHEEL:

Refer to the “**STARTER CLUTCH REMOVAL/INSPECTION/INSTALLATION**” section in the chapter 19

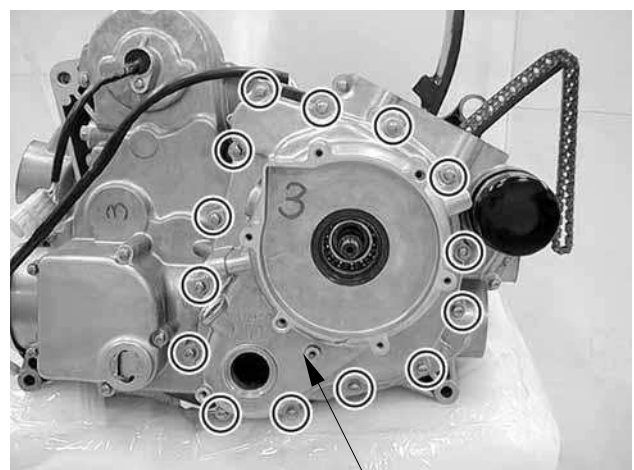

Right Crankcase Cover

18. IGNITION SYSTEM

IGNITION SYSTEM LAYOUT

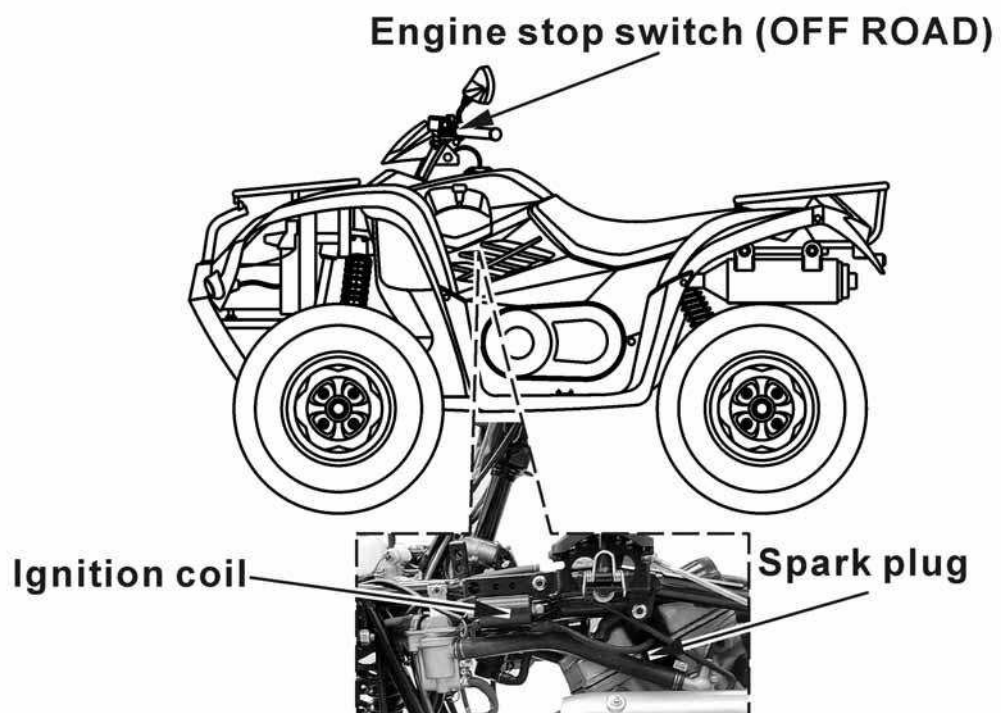
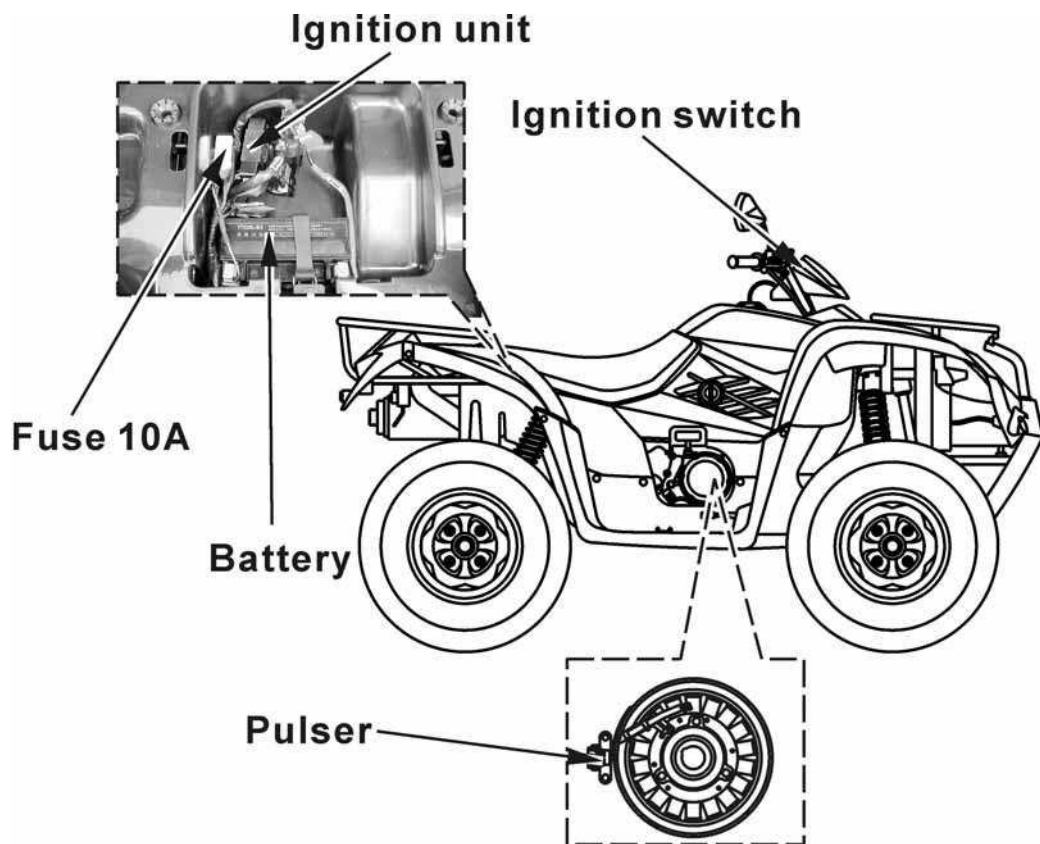

18. IGNITION SYSTEM

SERVICE INFORMATION

GENERAL INSTRUCTIONS

- Some electrical components may be damaged if terminals or connectors are connected or disconnected while the ignition switch is “ON” and current is present.
- When servicing the ignition system, always follow the steps in the troubleshooting on page 18-3.
- The ignition timing cannot be adjusted since the ignition control module is factory preset.
- The ignition control module may be damaged if dropped. Also, if the connector is disconnected when current is flowing, the excessive voltage may damage the ignition control module. Always turn off the ignition switch before servicing.
- A faulty ignition system is often related to poor connections. Check those connections before proceeding.
- Make sure the battery is adequately charged. Using the starter motor with a weak battery results in a slower engine cranking speed as well as no spark at the spark plug.
- Use a spark plug of the correct heat range. Using spark plug with an incorrect heat range can damage the engine.
- See section 17 for ignition pulse generator removal/installation.
- See section 20 for following components:
 - TM Ignition switch
 - TM Engine stop switch

SPECIFICATIONS

| Item | Standard |
|-----------------|----------------------------------|
| Spark plug | NGK-CR7E |
| Spark plug gap | 0.7 mm (0.028 in) |
| Ignition system | Full transistor digital ignition |
| Ignition timing | 5°/1500 rpm |

18. IGNITION SYSTEM

TROUBLESHOOTING

LOW PEAK VOLTAGE

- Cranking speed is too low (battery is undercharged).
- Poorly connected connectors or an open circuit in the ignition system.
- Faulty ignition-coil.
- Faulty ignition control module.

NO PEAK VOLTAGE

- Short circuit in engine stop switch or ignition switch wire.
- Faulty engine stop switch or ignition switch.
- Loose or poorly connected ignition control module connectors.
- Open circuit or poor connection in ground wire of the ignition control module.
- Faulty ignition pulse generator.
- Faulty ignition control module.

PEAK VOLTAGE IS NORMAL, BUT NO SPARK JUMPS AT THE PLUG

- Faulty spark plug or leaking ignition coil secondary current.
- Faulty ignition coil.

18. IGNITION SYSTEM

IGNITION COIL INSPECTION

IGNITION COIL PRIMARY PEAK VOLTAGE

Check cylinder compression and check that the spark plug is installed correctly in the cylinder. Disconnect the spark plug cap from the spark plug.



Spark Plug Cap

Connect known good spark plug to the spark plug cap and ground the spark plugs to the cylinder as done in the spark test.



Spark Plug

Spark Plug Cap

Turn the ignition switch to “ON” and engine stop switch ON.
Turn the engine stop switch in RUN (OFF ROAD).

Connect the multi-meter (+) probe to the Brown/Blue wire and the multi-meter (-) to the body ground.

Check for initial voltage at this time.
The battery voltage should be measured.

If the initial voltage cannot be measured, check the power supply circuit.



Ignition Coil

18. IGNITION SYSTEM

IGNITION PULSE GENERATOR INSPECTION

Disconnect the ignition pulse generator connector.
Measure the ignition pulse generator resistance between the Green/White wire and Blue/Yellow wire.

Standard: $489 \pm 20\% \Omega$ (20°C/68°F)

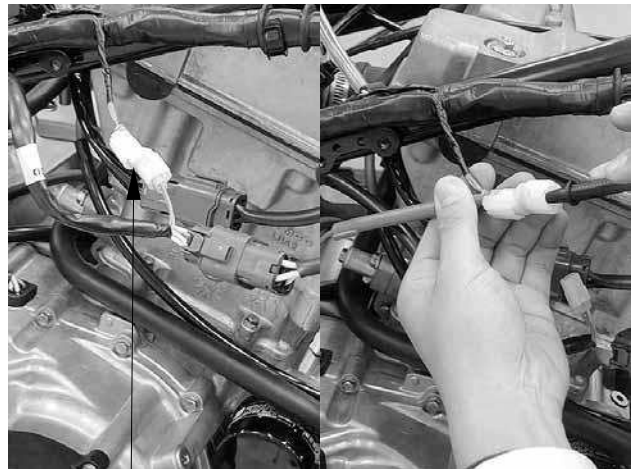

Ignition Pulse Generator Connector

IGNITION COIL REMOVAL/INSTALLATION

Disconnect the spark plug cap from the spark plug (page 18-4).

Disconnect the ignition coil primary connectors.
Remove the two bolts and the ignition coil.

Installation is in the reverse order of removal.

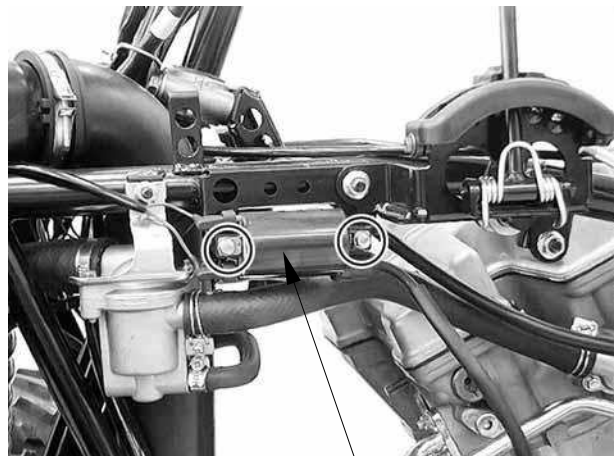

Ignition Coil

IGNITION CONTROL MODULE

REMOVAL/INSTALLATION
Remove the seat (refer to the “FRAME COVERS” section in the chapter 2).

Disconnect the ignition control module connectors and remove the ignition control module.

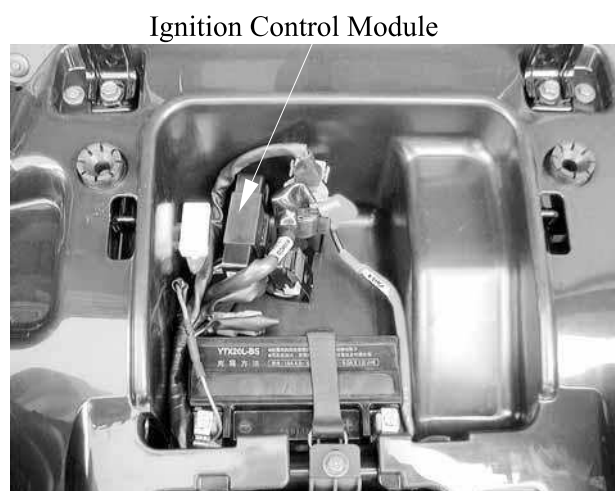

18. IGNITION SYSTEM

RESISTANCE INSPECTION

Measure the resistance between the terminals.

Due to the semiconductor in circuit, it is necessary to use a specified tester for accurate testing. Use of an improper tester in an improper range may give false readings.

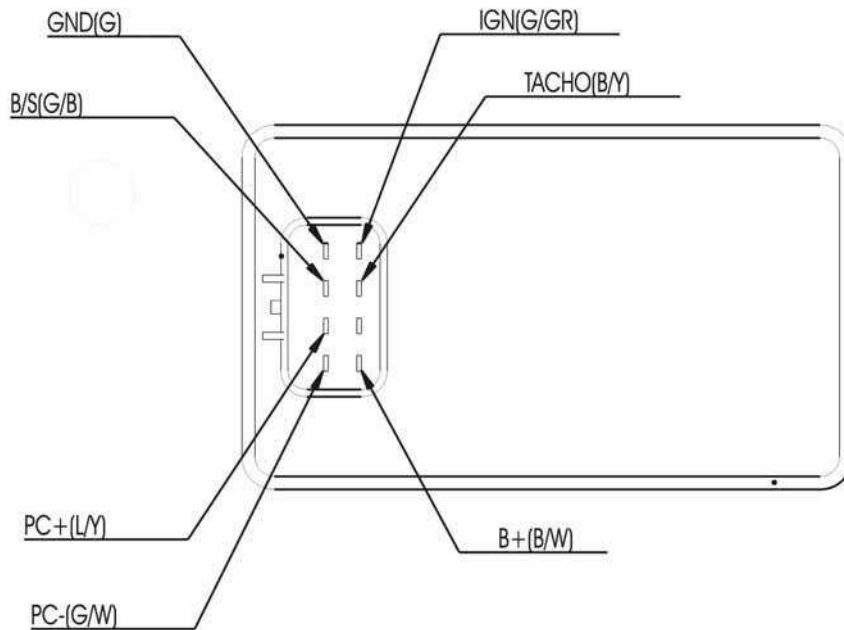

Unit: Ω

| (-) | (+) | B/W | G/GR | L/Y | G/W | B/Y | G |
|------|-----|-----|------|----------|---------|-----|----------|
| B/W | | | | | | | |
| G/GR | | | | 6.7 M | 6.7 M | | 6.7 M |
| L/Y | | | | | 0.785 K | | Continue |
| G/W | | | | 0.778 K | | | 0.785 k |
| B/Y | | | | | | | |
| G | | | | Continue | 0.785 K | | |

19. STARTER SYSTEM



STARTER SYSTEM

19

| | |
|--|-------|
| STARTING SYSTEM LAYOUT ----- | 19- 1 |
| SERVICE INFORMATION----- | 19- 2 |
| TROUBLESHOOTING----- | 19- 2 |
| STARTER MOTOR ----- | 19- 3 |
| STARTER RELAY SWITCH/STARTER MAG ----- | 19- 4 |
| RECOIL STARTER REMOVAL/INSPECTION/ INSTALLATION ----- | 19- 6 |
| RECOIL STARTER HANDLE REPLACE ----- | 19-11 |
| RECOIL STARTER DISASSEMBLY/INSPECTION/ ASSEMBLY ----- | 19-12 |
| STARTER PULLEY REMOVAL/INSPECTION/ INSTALLATION ----- | 19-15 |
| STARTER CLUTCH REMOVAL/INSPECTION/ INSTALLATION ----- | 19-17 |

19. STARTER SYSTEM

STARTING SYSTEM LAYOUT

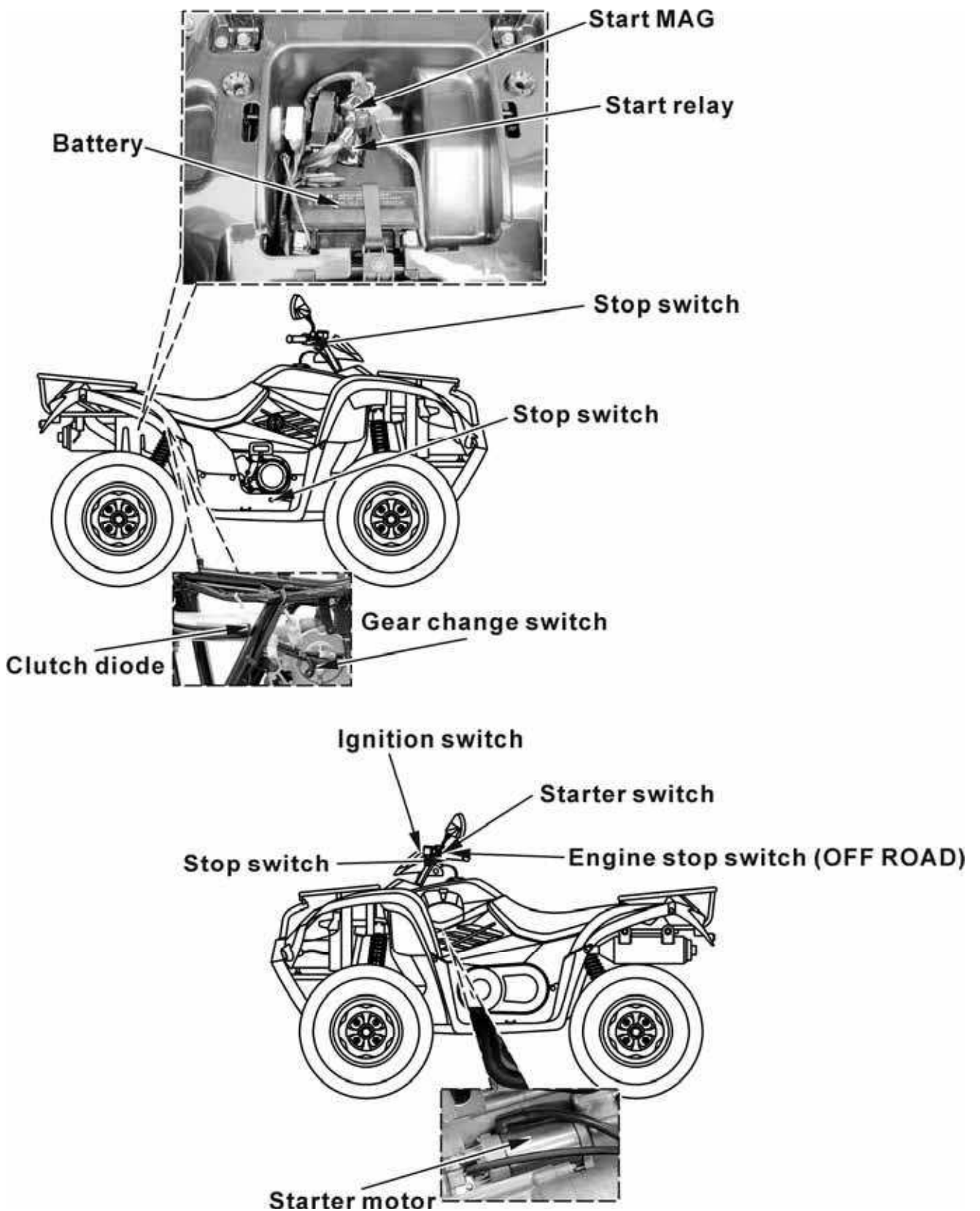

19. STARTER SYSTEM

SERVICE INFORMATION

GENERAL

- Always turn the ignition switch to “OFF” before servicing the starter motor. The motor could suddenly start, causing serious injury.
- The starter motor can be serviced with the engine in the frame.
- When checking the starter system, always follow the steps in the troubleshooting flow chart (page 19-2).
- A weak battery may be unable to turn the starter motor quickly enough, or supply adequate ignition current.
- If the current is kept flowing through the starter motor to turn it while the engine is not cranking over, the starter motor may be damaged.
- See section 20 for following components:
 - ™ Ignition switch
 - ™ Starter switch
 - ™ Brake light switch

SPECIAL TOOL

Flywheel puller A120E00060

TORQUE

Starter pulley nut 5.5 kgf-m (55 N-m, 40 lbf-ft)

TROUBLESHOOTING

- Check for the following before troubleshooting:
 - Blown main fuse (30A) and sub fuse (15 A)
 - Loose battery and starter motor cable
 - Discharged battery
- The starter motor can turn with the following conditions:
 - Ignition switch ON
 - Engine stop switch in RUN (OFF ROAD)
 - Rear brake lever fully squeezed
 - Starter switch pushed

19. STARTER SYSTEM

STARTER MOTOR

INSPECTION

Disconnect the starter motor cable from the starter MAG.
 Turn the ignition switch to “ON”.
 Connect the starter motor cable directly to the battery positive terminal.
 If the starter motor does not turn, the starter motor is faulty.

Starter Motor Cable



REMOVAL

Remove the carburetor (refer to the “**CARBURETOR REMOVAL/CHOKE INSPECTION/INSTALLATION**” section in the chapter 5).

Turn the ignition switch turned to “OFF”

Remove the two mounting bolts and starter motor.

Release the rubber cap and remove the terminal nut to disconnect the starter motor cable from the starter motor.

Rubber Cap

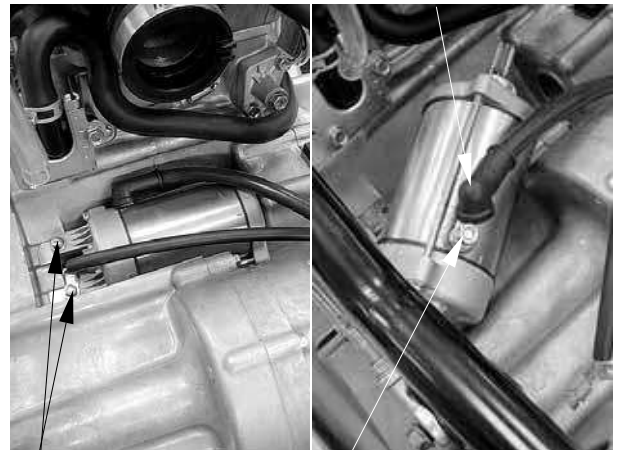

Bolts

Nut

INSTALLATION

Coat a new O-ring with engine oil and install it into the starter motor groove.

Connect the starter motor cable to motor terminal with the terminal nut and tighten it.

Install the starter motor into the crankcase.

Install the two mounting bolts and tighten them securely.

O-ring



19. STARTER SYSTEM

STARTER RELAY SWITCH/STARTER MAG

INSPECTION

Turn the ignition switch to “ON”.

Squeeze the brake lever or pedal fully.
The coil is normal if the starter relay switch clicks.

Squeeze and hold the brake lever or pedal fully then push the starter switch.
The coil is normal if the starter MAG switch clicks.

If you do not hear the switch click. Inspect the relay switch and starter MAG using the procedure below.

GROUND LINE INSPECTION

Disconnect the starter relay switch connector.
Check for continuity between the Green wire terminal and ground.

There should be continuity.

VOLTAGE INSPECTION

Connect the starter MAG connector.
Turn the ignition switch ON.

Measure the starter MAG Yellow/Red wire terminal and ground.

If the battery voltage appears only when the rear brake lever is squeezed fully (or the gear change switch in neutral) and starter switch is pushed, the circuit is normal.

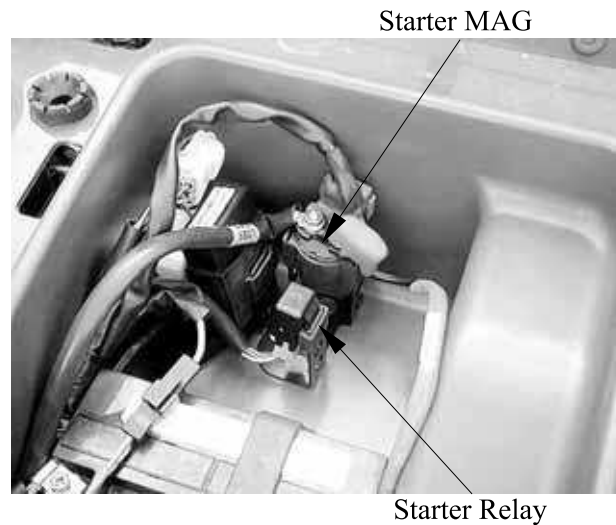

19. STARTER SYSTEM

CONTINUTY INSPECTION

Disconnect the starter MAG switch connector and cables.

Connect a fully charged 12 V battery positive wire to the relay switch Yellow/Red wire terminal and negative wire to the Yellow/Green wire terminal.

There should be continuity between the cable terminals while the battery is connected, and no continuity when the battery is disconnected.



19. STARTER SYSTEM

RECOIL STARTER REMOVAL/INSPECTION/ INSTALLATION

The recoil starter can not start the engine when the battery is removal.

REMOVAL

Remove the six bolts, then remove the recoil starter assembly.

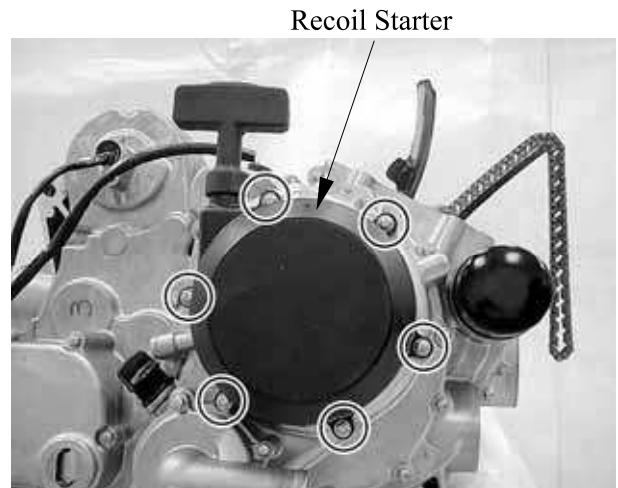

Remove the two dowel pins.

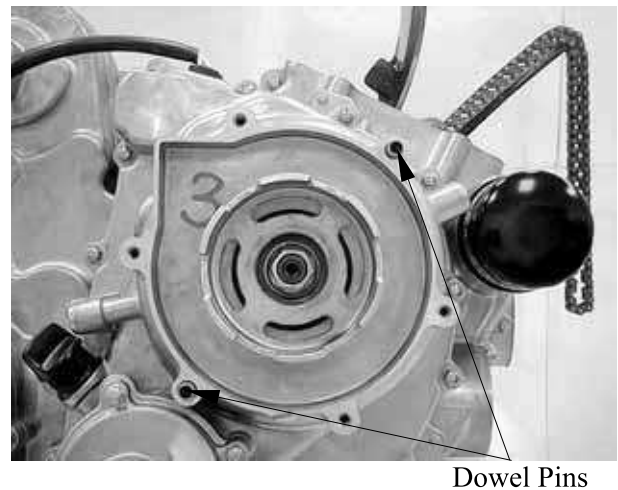

INSTALLATION

Install the dowel pins.

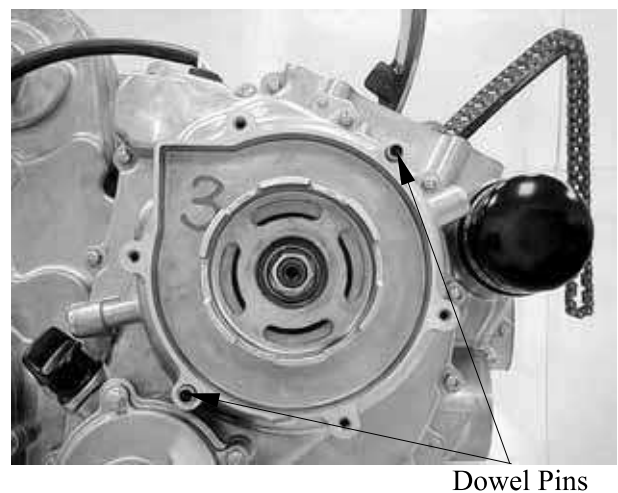

19. STARTER SYSTEM

Install the recoil starter assembly.
Install and tighten the six bolts diagonally.

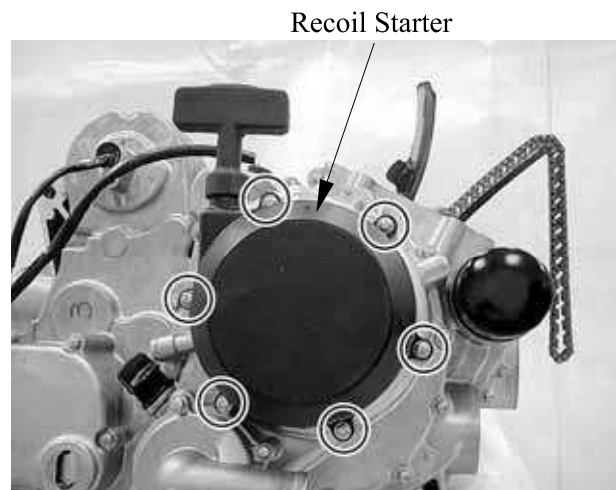

19. STARTER SYSTEM

RECOIL STARTER HANDLE REPLACE

Remove the recoil starter assembly (refer to the “RECOIL STARTER REMOVAL/INSPECTION/INSTALLATION” section in this chapter).

Remove the cap on the handle.



Replace the handle.

Before untying the knot above the starter handle, make a knot in the rope so that the rope is not pulled into the housing.

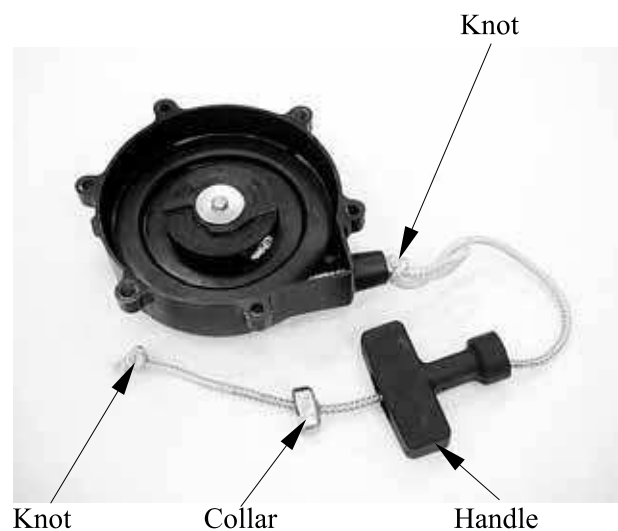

19. STARTER SYSTEM

RECOIL STARTER DISASSEMBLY/INSPECTION/ ASSEMBLY

DISASSEMBLY

Remove the recoil starter assembly (refer to the “**RECOIL STARTER REMOVAL/INSPECTION/INSTALLATION**” section in this chapter).

Remove the handle (refer to the “**RECOIL STARTER HANDLE REPLACE**” section in this chapter).

Untying the knot, then turn the reel clockwise with the rope slowly.

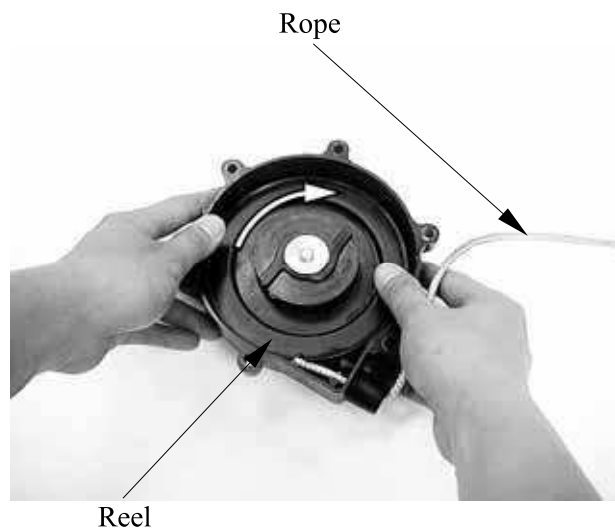

Remove the bolt and then remove the washer, friction plate and pawl spring.



19. STARTER SYSTEM

Remove the reel, then remove the coil spring.

Wear hand and eye protection when removing the reel, since the spring may quickly unwind and cause an injury.

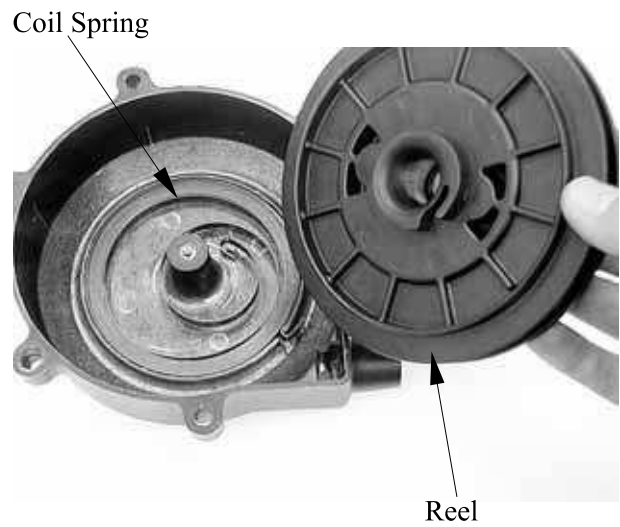

INSPECTION

Pull the rope and check that the ratchet is pushed out.



Inspect the rope, reel and drive pawl for wear or damage.

Inspect the pawl spring for fatigue.

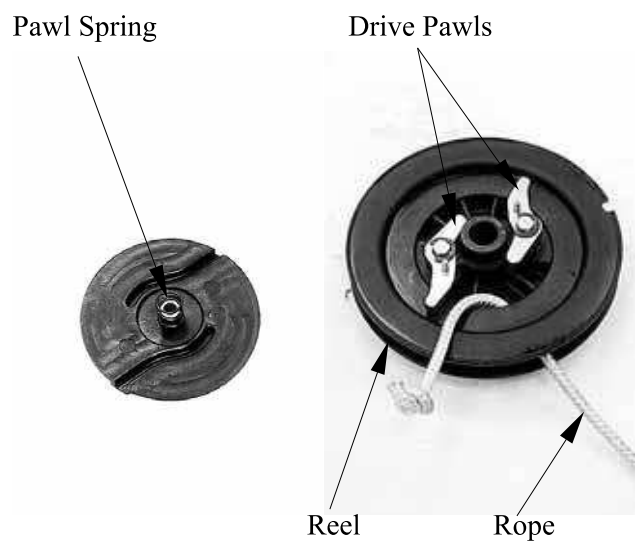

19. STARTER SYSTEM

Inspect the coil spring for fatigue.

Coil Spring



ASSEMBLY

Apply molybdenum disulfide grease to the coil spring, then install the coil spring.

- Wear hand and eye protection when installing the spring, since the spring may quickly unwind and cause an injury.
- Mesh the spring hook with the housing slit, then wind the housing to make the diameter of the spring smaller and the spring will be into the housing.

Hook

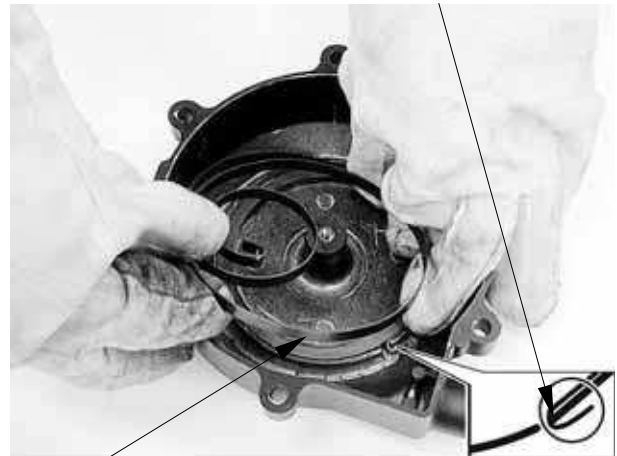

Coil Spring

Pass the rope through the reel and make a knot above the reel.

Reel

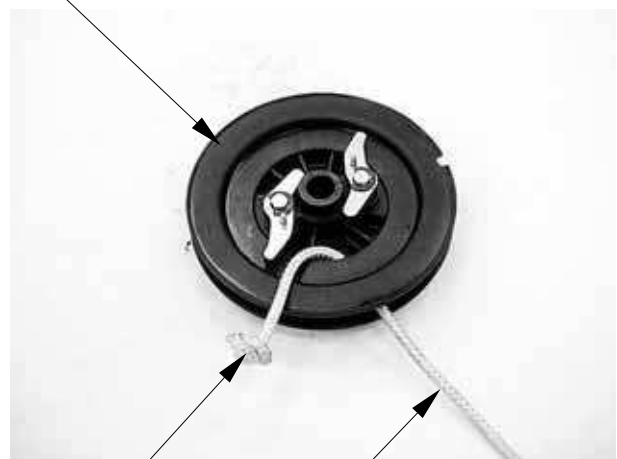

Knot

Rope

19. STARTER SYSTEM

Install the reel.

- Wear hand and eye protection when installing the reel, since the spring may quickly unwind and cause an injury.
- Engage the part of the reel with coil spring end.

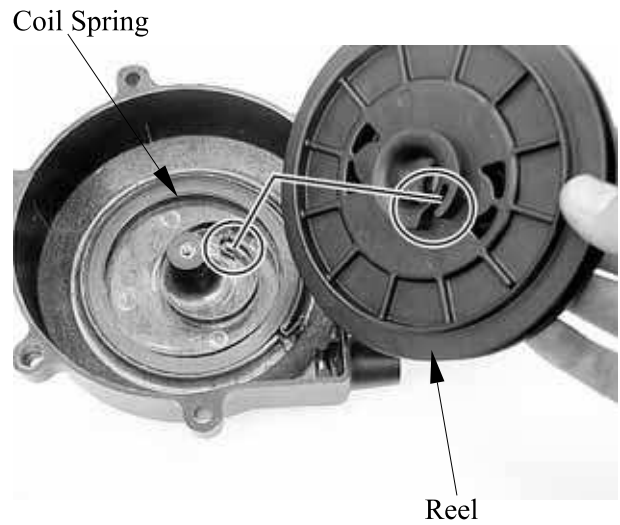

Hook the rope onto the hook part of the reel, then pass the rope through the recoil starter housing, handle and collar. Make a knot above the collar.

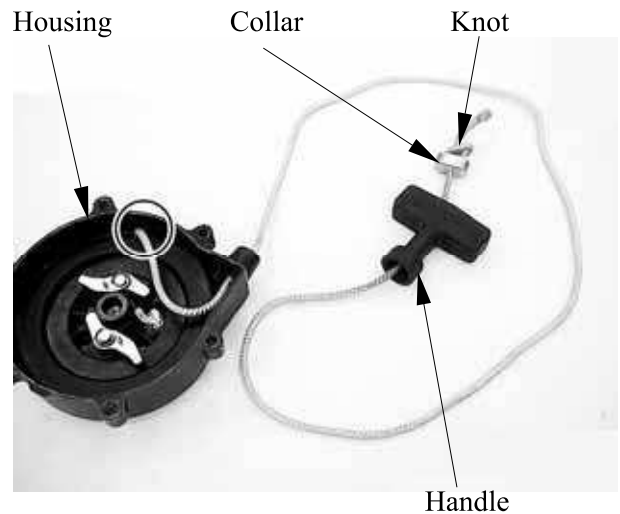

Hook the rope onto the hook part of the reel, turn the reel counterclockwise three or four times with the rope.

- Wear hand and eye protection when assembling the recoil starter, since the spring may quickly unwind and cause an injury.



19. STARTER SYSTEM

Unhook the rope, then turn the reel clockwise with the rope slowly.

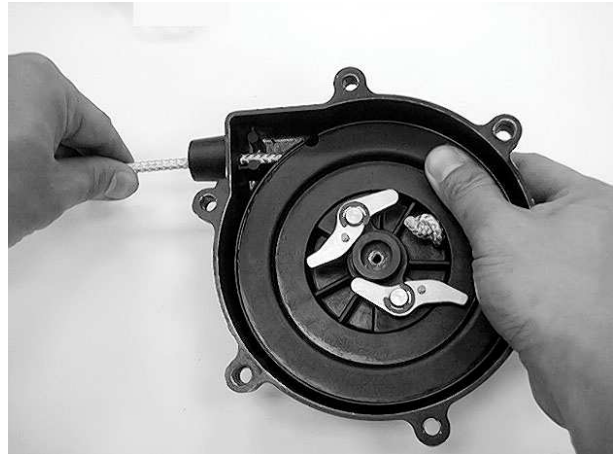

Apply molybdenum disulfide grease to the washer and friction plate.

Apply Grease

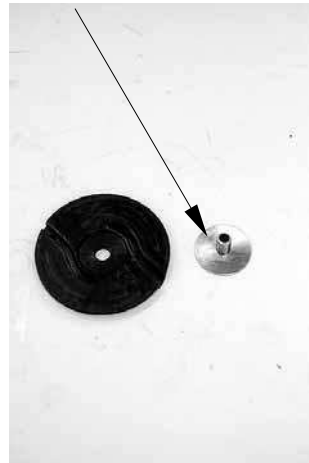

Apply Grease

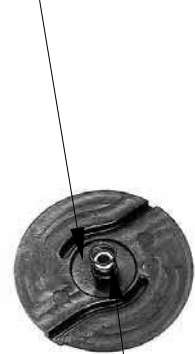

Spring

Install the pawl spring, friction plate/washer.
Install and tighten the new bolt securely.

Bolt/Washer/Plate/Spring



19. STARTER SYSTEM

Pull the rope and check that the ratchet is pushed out.



19. STARTER SYSTEM

STARTER PULLEY REMOVAL/INSPECTION/ INSTALLATION

REMOVAL

Remove the recoil starter assembly (refer to the “**RECOIL STARTER REMOVAL/INSPECTION/INSTALLATION**” section in this chapter).

Remove the starter pulley nut by using a suitable bar.

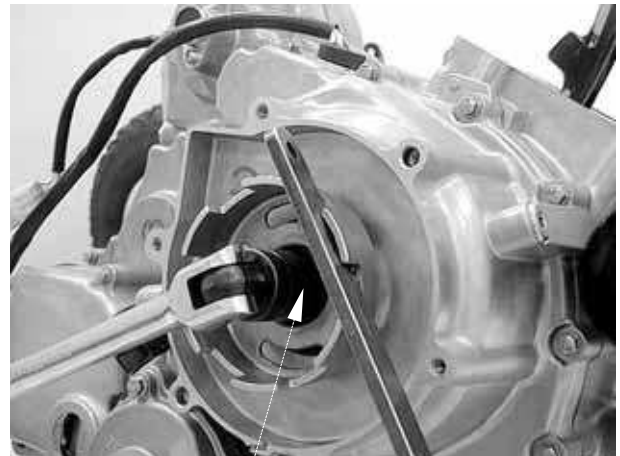

Nut/Washer

INSPECTION

Inspect the starter pulley for cracks or pitting.
Inspect the O-ring for wear or damage.

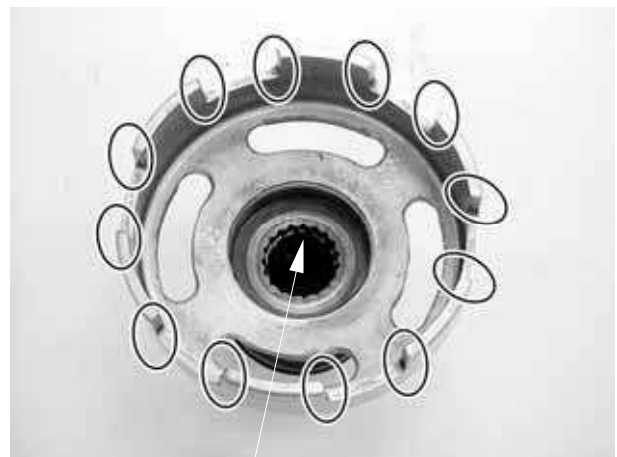

O-ring

Inspect the oil stop ring for crack or damage.



Oil Stop Ring

19. STARTER SYSTEM

INSTALLATION

Install the starter pulley and washer.
Install and tighten the nut to the specified torque by using suitable bar.

Torque: 5.5 kgf-m (55 N-m, 40 lbf-ft)

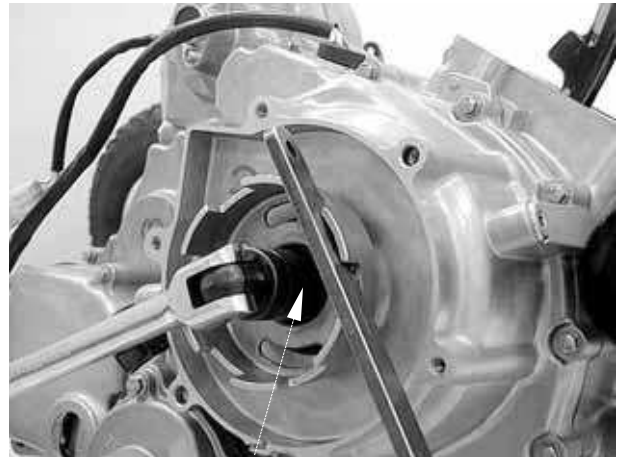

Nut/Washer

19. STARTER SYSTEM

STARTER CLUTCH REMOVAL/INSPECTION/ INSTALLATION

REMOVAL

Remove the right crankcase cover (refer to the “**ALTERNATOR STATOR REMOVAL/INSPECTION/INSTALLATION**” section in the chapter 17).

Remove the flywheel/driven gear by using the special tool.

Special tool:

Flywheel puller A120E00060

Remove the woodruff key.

Remove the reduction gear.

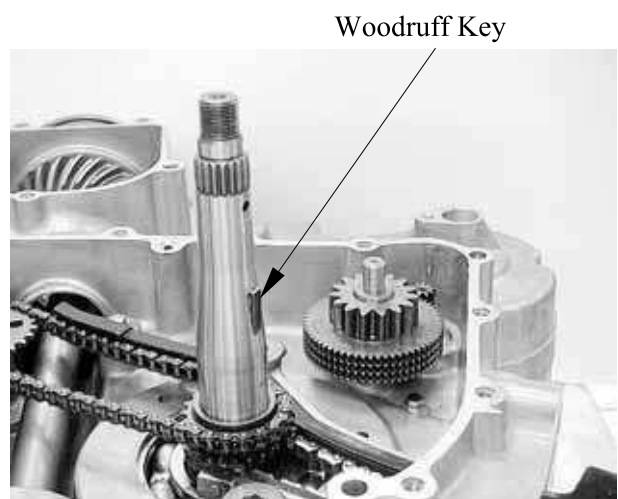
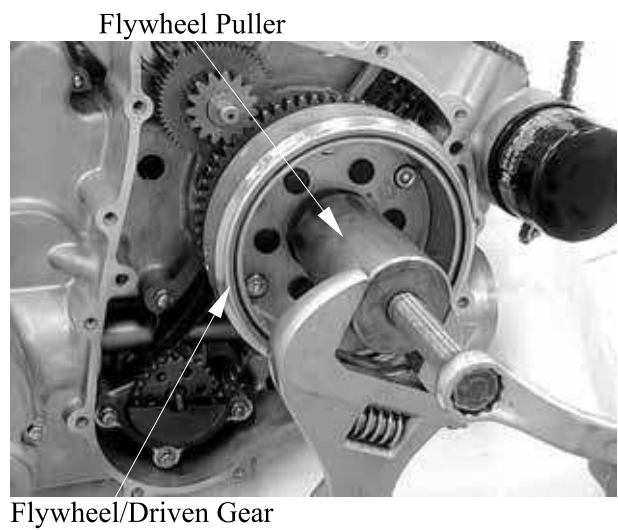

19. STARTER SYSTEM

INSPECTION

Check the operation of the sprag clutch by turning the driven gear. You should be able to turn the driven gear clockwise smoothly, but the gear should not turn counterclockwise.

Remove the starter driven gear by turning the driven gear.



Check the starter driven gear teeth for wear or damage.

Measure the starter driven gear boss O.D..

Service limit: 57.7 mm (2.272 in)

Measure the starter driven gear bushing I.D..

Service limit: 27.1 mm (1.084 in)

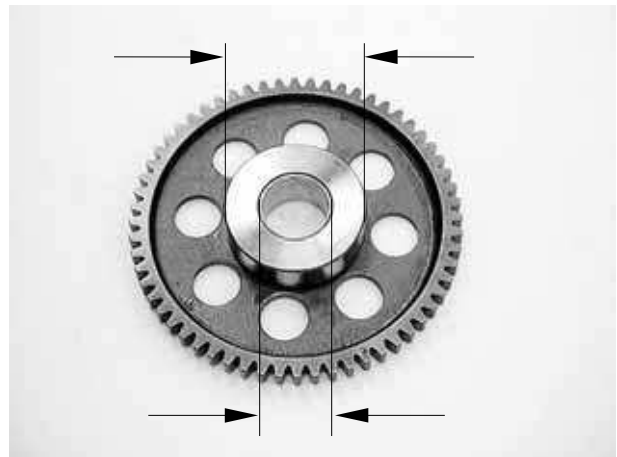

Check the starter reduction gear teeth and shaft for wear or damage.



19. STARTER SYSTEM

INSTALLATION

Apply oil to the starter reduction gear.
Install the starter reduction gear to the right crankcase.



Install the woodruff key in the crankshaft key groove.

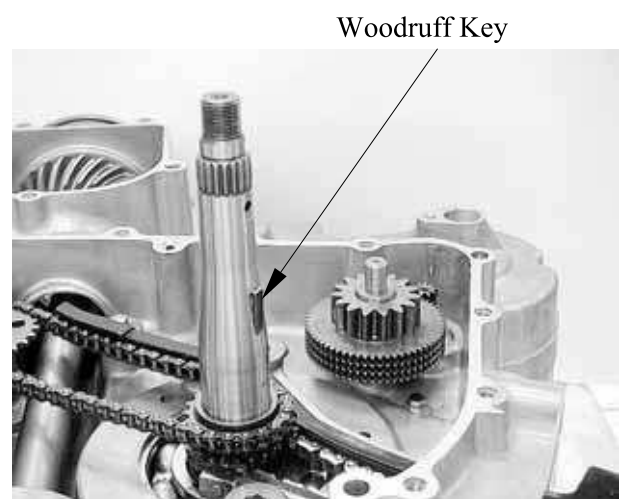

Apply molybdenum oil solution to the starter driven gear bushing.
Install the starter driven gear by turning the driven gear clockwise.



19. STARTER SYSTEM

Clean any oil from the tapered portion of the flywheel I.D.

Install the flywheel/driven gear onto the crankshaft, aligning the key way with woodruff key.

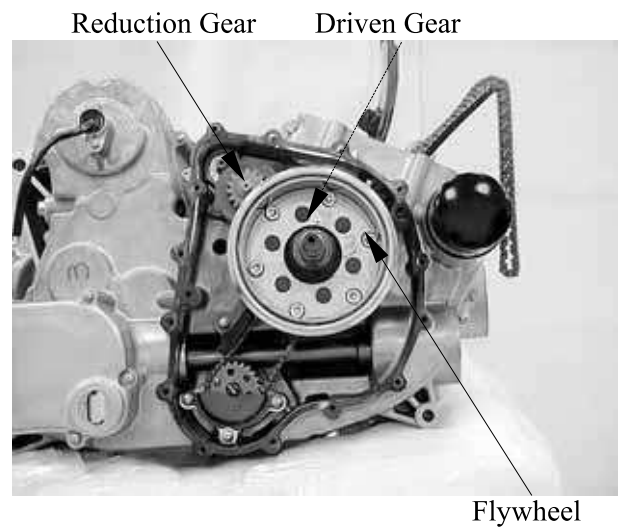

20. LIGHTS/SWITCHES

LIGHTS/SWITCHES

| | |
|----------------------------|-------|
| SERVICE INFORMATION----- | 20- 1 |
| BULBS REMOVAL----- | 20- 2 |
| HORN (ON ROAD)----- | 20- 4 |
| IGNITION SWITCH----- | 20- 5 |
| HANDLEBAR SWITCH----- | 20- 5 |
| GEAR INDICATOR SWITCH----- | 20- 8 |
| SPEED SENSOR----- | 20- 9 |
| FUEL UNIT----- | 20-10 |

20. LIGHTS/SWITCHES

SERVICE INFORMATION

- A continuity test can be made with the switches installed on the vehicle.
- All plastic connectors have locking tabs that must be released before disconnecting, and must be aligned when reconnecting.
- To isolate an electrical failure, check the continuity of the electrical path through the part. A continuity check can usually be made without removing the part from the vehicle. Simply disconnect the connectors and connect a continuity tester to the terminals or connections.

20. LIGHTS/SWITCHES

BULBS REMOVAL

HEADLIGHT

Disconnect the headlight wire connector.
Remove the rubber boot from the headlight case.

Headlight Connector



Rubber Boot

Relax the lock clip to remove the bulb and replace with a new one.

Install the bulb, aligning the bulb socket groove with the bulb tab and set the lock clip.

Connect headlight wire connector.
Install the rubber boot.

Install the front fender in the reverse order of removal.

Lock Clip



Bulb

POSITION LIGHT

Remove the bulb socket by pulling it out.
Remove the bulb.

Install the bulb in the reverse order of removal

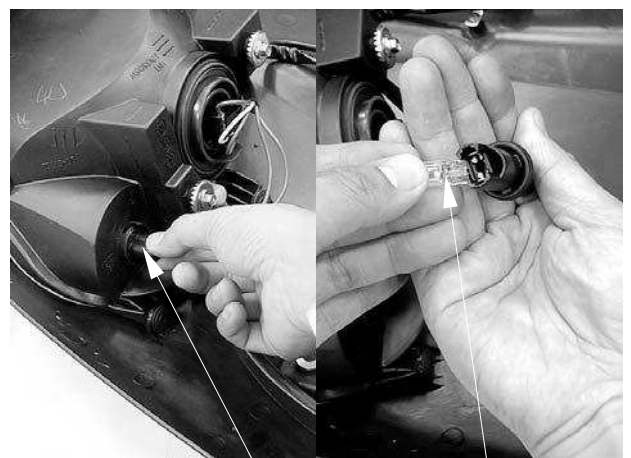

Bulb Socket

Bulb

20. LIGHTS/SWITCHES

TAIL/BRAKE LIGHT

Remove the bulb socket by turning it counterclockwise.
Remove the bulb.

Install the bulb in the reverse order of removal.

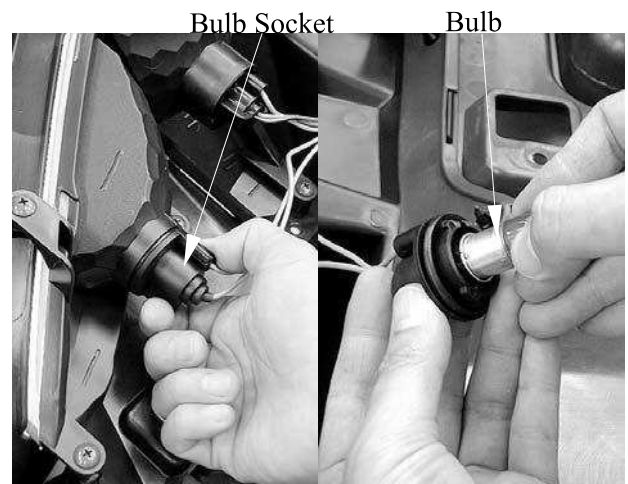

TURN SIGNAL LIGHT (ON ROAD)

FRONT

Remove the rubber boot from the turn signal light case.
Remove the bulb socket by turning it counterclockwise.

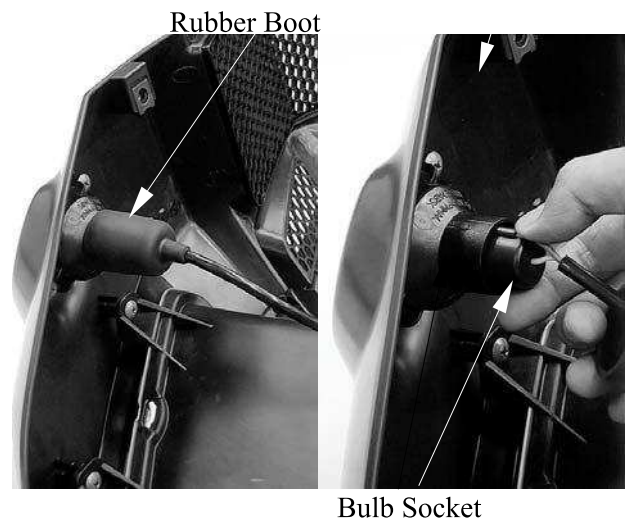

Remove the bulb.

Install the bulb in the reverse order of removal.

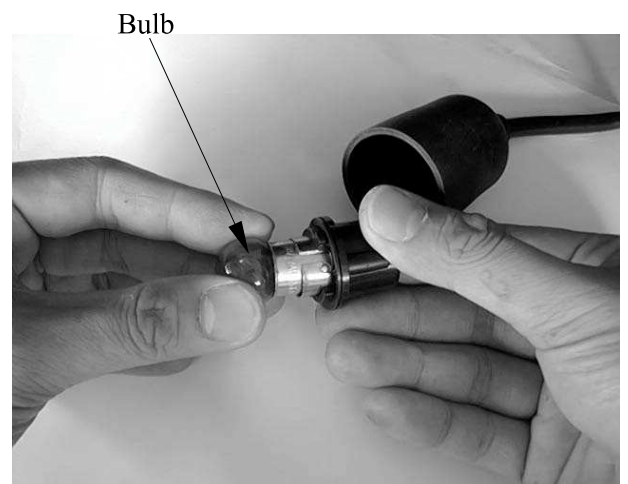

20. LIGHTS/SWITCHES

REAR

Remove the bulb socket by turning it counterclockwise.

Remove the bulb.

Install the bulb in the reverse order of removal.

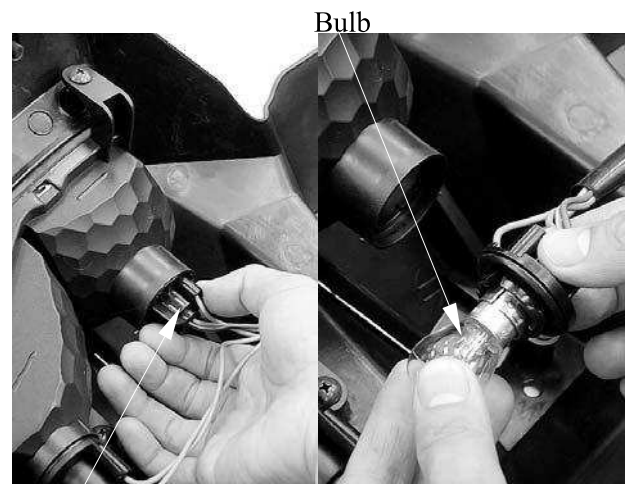

Bulb Socket

LICENCE LIGHT BULB (ON ROAD)

Remove the two screws and licence light cover.

Remove the bulb.

Install the bulb in the reverse order of removal

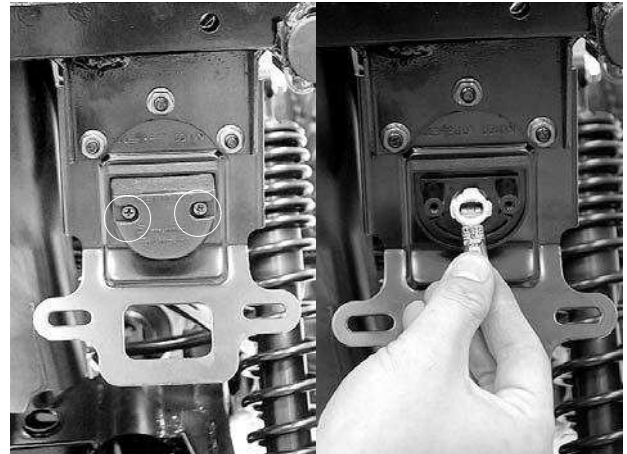

HORN (ON ROAD)

REMOVAL

Disconnect the horn wire leads.
Remove the bolt and remove horn.

INSTALLATION

The installation sequence is the reverse of removal.

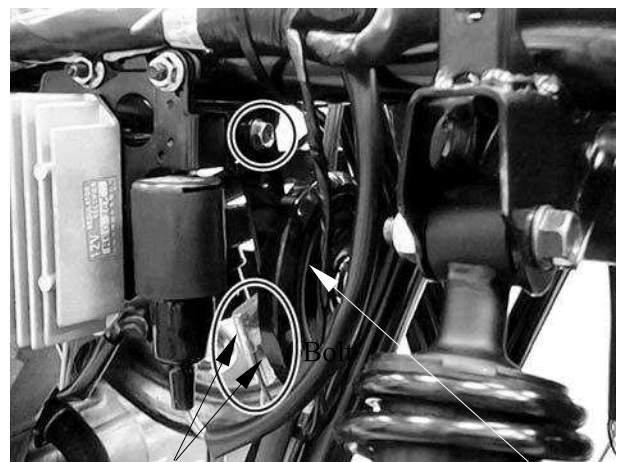

Horn Wire Leads

Horn

20. LIGHTS/SWITCHES

IGNITION SWITCH

INSPECTION

Disconnect the ignition switch connectors.
(Refer to the “**FRAME COVER**” section in the chapter 2.)

Check for continuity between the switch side connector terminals in each switch position.

Continuity should exist between the color coded wires as right:

| | IG | E | BAT1 | BAT2 | PO |
|-------|-----|---|------|------|----|
| OFF | ○ | ○ | | | |
| ON | | | ○ | ○ | |
| PO | | | ○ | ○ | ○ |
| COLOR | B/W | G | R | B | BR |

REPLACEMENT

Release the switch wire from the wire clips on the steering shaft holder frame pipe.

Remove the meter cover (refer to the “**FRAME COVER**” section in the chapter 2).

Remove the ignition switch from the cover while pushing in the two stoppers.

Install a new ignition switch by aligning the locating tab with the groove in the cover.

Install the removed parts in the reverse order of removal.

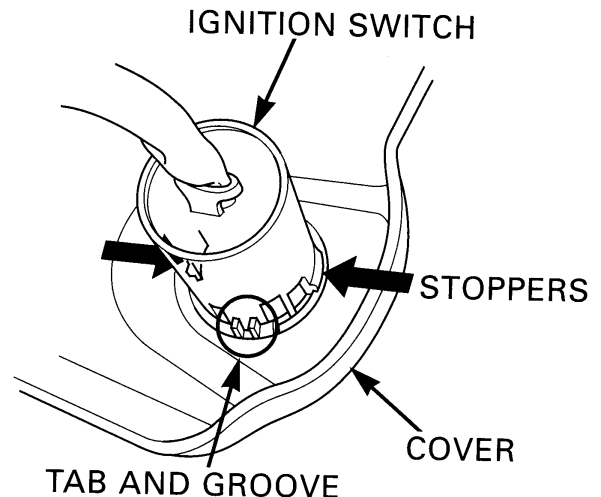

HANDLEBAR SWITCH

INSPECTION

Remove front center cover (refer to the “**FRAME COVER**” section in the chapter 2).

Disconnect the connectors.

Check for continuity between the switch side connector terminals in each switch position.

Continuity should exist between the color coded wires as next page:

20. LIGHTS/SWITCHES

(ON ROAD)

HORN SW

| | | |
|-------|----|-----|
| | HO | BAT |
| FREE | | |
| PUSH | ○ | ○ |
| COLOR | LG | B |

WINKER SW

| | | | |
|-------|----|---|----|
| | R | L | WR |
| L | | ○ | ○ |
| R | ○ | | ○ |
| COLOR | SB | O | GR |

START SW

| | | |
|-------|-----|------|
| | ST | C |
| FREE | | |
| PUSH | ○ | ○ |
| COLOR | Y/R | Y/BR |

LIGHT SW

| | | | |
|-------|------|----|----|
| | PO | LO | HI |
| ☰ | ○ | | |
| ☰ | ○ | ○ | |
| ☰ | ○ | | ○ |
| COLOR | BR/B | W | L |

HAZARD SW

| | | |
|-------|-----|-----|
| | BAT | HA |
| △ | ○ | ○ |
| ● | | |
| COLOR | R/W | Y/B |

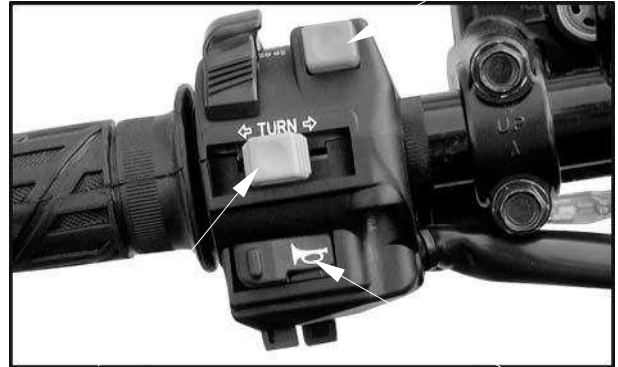

2WD/4WD SW

| | | | |
|----------|-----|-----|-----|
| | 2WD | 4WD | |
| 4WD LOCK | ○ | ○ | ○ |
| 4WD | ○ | ○ | |
| 2WD | ○ | | |
| COLOR | G | W/L | W/O |



20. LIGHTS/SWITCHES

(OFF ROAD)

ENGINE STOP SW

| | | |
|-------|------|-----|
| | E | IG |
| | | |
| | | |
| COLOR | BR/L | B/W |

START SW

| | | |
|-------|-----|-----|
| | ST | C |
| FREE | | |
| PUSH | | |
| COLOR | Y/R | B/W |

DIMMER SW

| | | | |
|-------|------|----|----|
| | HL | LO | HI |
| | | | |
| | | | |
| | | | |
| COLOR | BR/B | W | L |

PASSING SW

| | | |
|-------|------|---|
| | ST | C |
| FREE | | |
| PUSH | | |
| COLOR | BR/L | L |

Dimmer Switch



Start Switch

Passing Switch

Engine Stop Switch

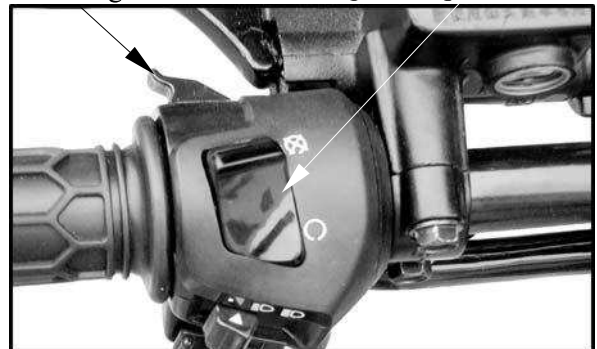

2WD/4WD SW

| | | | |
|----------|-----|-----|-----|
| | 2WD | 4WD | |
| 4WD LOCK | | | |
| 4WD | | | |
| 2WD | | | |
| COLOR | G | W/L | W/O |



20. LIGHTS/SWITCHES

GEAR INDICATOR LIGHT SWITCHES

INSPECTION

Disconnect the gear indicator light switch wire connector.

Check for continuity between the switch side connector terminal and engine ground.

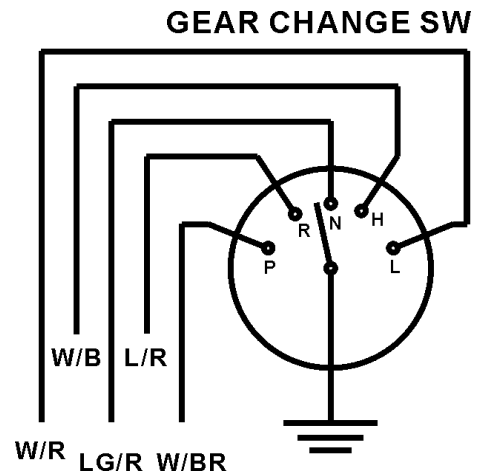

REPLACEMENT

Disconnect the gear indicator light switch connector.

Remove the bolt, then remove the gear indicator light switch and washer.

Gear Indicator Light Switch

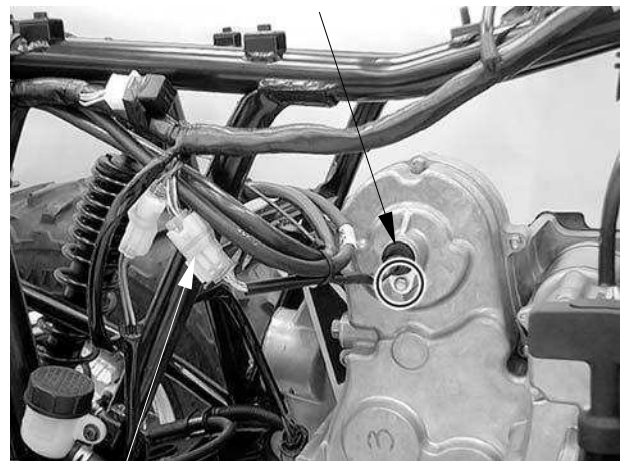

r

Install the washer and a new switch with a new O-ring (apply engine oil to O-ring).

* Make sure that the lever on the gear indicator light switch correctly engages with the locating slot on the shift shaft.

Shift the drive select lever to check if the gear indicator light is correct.

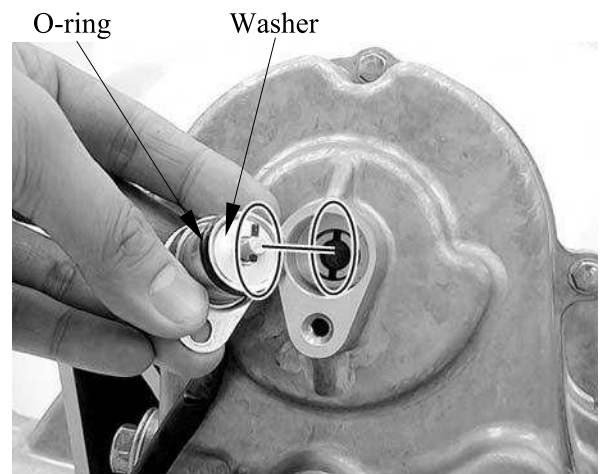

20. LIGHTS/SWITCHES

SPEED SENSOR

Disconnect the connector.

Remove the bolt then remove the speed sensor.

If the speedometer, odometer or trip meter does not function properly. Inspect the connection of speed sensor connector.

If the connection is all right, replace the speedometer with a new one.

If the speedometer, odometer or trip meter still does not function properly, replace the speed sensor.



Speed Sensor

20. LIGHTS/SWITCHES

FUEL UNIT

REMOVAL

Remove the fuel tank cover (refer to the “**FRAME COVERS**” section in the chapter 2).

Remove the fuel unit connectors.
Remove the four bolts, then remove the fuel unit from fuel tank.

INSPECTION

Measure the resistance between the Yellow/White and Blue/White terminals of the fuel unit connector.

Standard (at 20°C/68°F):

| | |
|-------------------------|-------------|
| Float at full position | 1100 ± 33 Ω |
| Float at empty position | 100 ± 3 Ω |

INSTALLATION

Fuel unit installation is in the reverse order of removal.

* Align the tab on the fuel unit with the mark on the fuel tank.

Fuel Unit Connectors

