

1. GENERAL INFORMATION



GENERAL INFORMATION

SERIAL NUMBER-----	1-01
SPECIFICATION-----	1-02
SERVICE PRECAUTIONS -----	1-04
TORQUE VALUES -----	1-12
SPECIAL TOOLS -----	1-17
LUBRICATION POINTS -----	1-20

1. GENERAL INFORMATION

SERIAL NUMBER



(1) Location of Frame Serial Number



(1) Location of Engine Serial Number

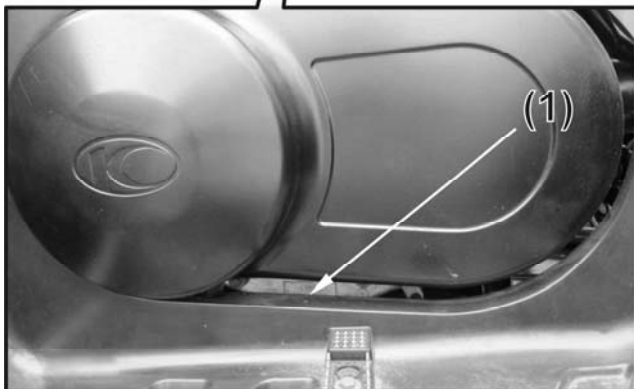

1. GENERAL INFORMATION

SPECIFICATIONS :MXU550EXi

Model No.		LEA0AD/LEA0AE	
Name		MXU 550 EXi	
Overall length		2210 mm	
Overall width		1220 mm	
Overall height		1265mm	
Wheel base		1297 mm	
Engine type		4 stroke D.O.H.C.	
Displacement		501 CC	
Fuel used		92# nonleaded gasoline	
Dry weight	Front wheel	175/187 kg	
	Rear wheel	170/173kg	
	Total	345kg /360kg	
Curb weight	Front wheel	184/196 kg	
	Rear wheel	179/182kg	
	Total	363kg /378kg	
Tires	Front wheel	AT26X8-14	
	Rear wheel	AT26X10-14	
Ground clearance		275 mm	
Min. turning radius		3450mm	
Engine	Starting system		Electric
	Type		Gasoline, 4-stroke
	Cylinder arrangement		Single cylinder
	Combustion chamber type		Semi-sphere
	Valve arrangement		DOHC.,chain drive
	Bore x stroke		92X75.4 mm
	Compression ratio		10.7:1
	Compression pressure		15 kg/cm ²
	Intake valve (at 1mm lift)	Opens	-1° BTDC
		Closes	48° ABDC
	Exhaust valve (at 1mm lift)	Opens	45° BBDC
		Closes	5° ATDC
	Valve clearance (cold)	Intake	0.1 mm
		Exhaust	0.1 mm
	Idle speed (rpm)		1400 ±100rpm
	Cooling type		Liquid cooled

Lubrication System	Lubrication type		Forced pressure & Wet sump	
	Oil pump type		Trochoid	
	Oil filter type		Full-flow filtration	
	Oil capacity		3.6 L	
	Oil exchanging capacity		3.0 L	
Fuel System	Air cleaner type & No		Wet type element	
	Fuel capacity		16.5 L	
	THR. body	Type	KYMCO PTA1	
		VENTURE DIA	38mm	
Electrical Equipment	Ignition System	Type	Full transistor digital ignition	
		Ignition timing	12°/IDLE rpm	
		Spark plug	CR7E (NGK)	
		Spark plug gap	0.6~0.7mm	
Battery	Capacity	12V18AH		
Drive Train	Clutch type		Wet, centrifugal automatic	
	Clutch operation system		Automatic (V-belt)	
	Primary reduction system		V-belt	
	Secondary reduction system		Shaft drive	
	Forward drive high radio		8.770~30.067	
	Forward drive low radio		16.279~55.814	
Reverse drive ratio		13.381~45.878		
Moving Device	FR/RR tire rolling circumference		2092/2079 mm(LEA0AD) 2073/2073 mm(LEA0AE)	
	Tire pressure	Front	0.38 kgf/cm ² (38 Kpa, 5.4psi)	
		Rear	0.35 kgf/cm ² (35Kpa, 4.97psi)	
	Turning angle	Left	41°	
Right		41°		
Brake system type	Front	Disk brake		
	Rear	Disk brake		
Suspension type	Front	Dual A-Arm		
	Rear	Dual A-Arm		

1. GENERAL INFORMATION

MXU 550EXi/MXU500i

SPECIFICATIONS :MXU500i

Model No.		LDA0CA	
Name		MXU 500i	
Overall length		2210 mm	
Overall width		1220 mm	
Overall height		1265mm	
Wheel base		1297 mm	
Engine type		4 stroke D.O.H.C.	
Displacement		498.5CC	
Fuel used		92# nonleaded gasoline	
Dry weight	Front wheel	170 kg	
	Rear wheel	159kg	
	Total	329kg	
Curb weight	Front wheel	178 kg	
	Rear wheel	169kg	
	Total	349kg	
Tires	Front wheel	AT25X8-12	
	Rear wheel	AT25X10-12	
Ground clearance		265 mm	
Min. turning radius		3450mm	
Engine	Starting system		Electric
	Type		Gasoline, 4-stroke
	Cylinder arrangement		Single cylinder
	Combustion chamber type		Semi-sphere
	Valve arrangement		DOHC.,chain drive
	Bore x stroke		92X75 mm
	Compression ratio		10.5:1
	Compression pressure		15 kg/cm ²
	Intake valve (at 1mm lift)	Opens	-1° BTDC
		Closes	48° ABDC
	Exhaust valve (at 1mm lift)	Opens	45° BBDC
		Closes	5° ATDC
	Valve clearance (cold)	Intake	0.1 mm
		Exhaust	0.1 mm
	Idle speed (rpm)		1400 ±100rpm
	Cooling type		Liquid cooled

Lubrication System	Lubrication type		Forced pressure & Wet sump	
	Oil pump type		Trochoid	
	Oil filter type		Full-flow filtration	
	Oil capacity		3.6 L	
	Oil exchanging capacity		3.0 L	
Fuel System	Air cleaner type & No		Wet type element	
	Fuel capacity		16.5 L	
	THR. body	Type	KYMCO PTA1	
		VENTURE DIA	38mm	
Electrical Equipment	Ignition System		Type	Full transistor digital ignition
			Ignition timing	12°/IDLE rpm
			Spark plug	CR7E (NGK)
			Spark plug gap	0.6~0.7mm
	Battery	Capacity	12V18AH	
Drive Train	Clutch type		Wet, centrifugal automatic	
	Clutch operation system		Automatic (V-belt)	
	Primary reduction system		V-belt	
	Secondary reduction system		Shaft drive	
	Forward drive high ratio		8.770~30.067	
	Forward drive low ratio		16.279~55.814	
Reverse drive ratio		13.381~45.878		
Moving Device	FR/RR tire rolling circumference		1995/1995	
	Tire pressure	Front	0.35 kgf/cm ² (35 Kpa, 5.0psi)	
		Rear	0.32 kgf/cm ² (32Kpa, 4.5psi)	
	Turning angle	Left	41°	
Right		41°		
Brake system type	Front	Disk brake		
	Rear	Disk brake		
Suspension type	Front	Dual A-Arm		
	Rear	Dual A-Arm		

1. GENERAL INFORMATION

SERVICE PRECAUTIONS

- Make sure to install new gaskets, O-rings, circlips, cotter pins, etc. when reassembling.

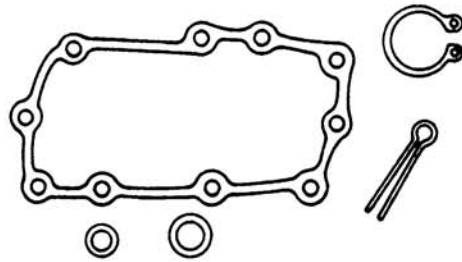

- When tightening bolts or nuts, begin with larger-diameter to smaller ones at several times, and tighten to the specified torque diagonally.

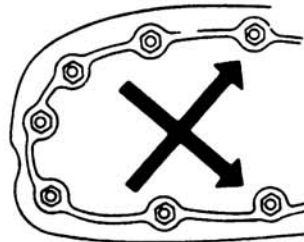

- Use genuine parts and lubricants.

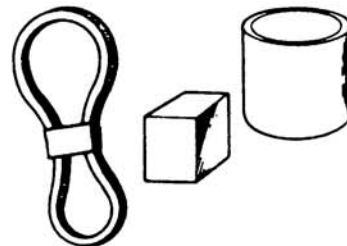

- When servicing the motorcycle, be sure to use special tools for removal and installation.



- After disassembly, clean removed parts. Lubricate sliding surfaces with engine oil before reassembly.



1. GENERAL INFORMATION

- Apply or add designated greases and lubricants to the specified lubrication points.

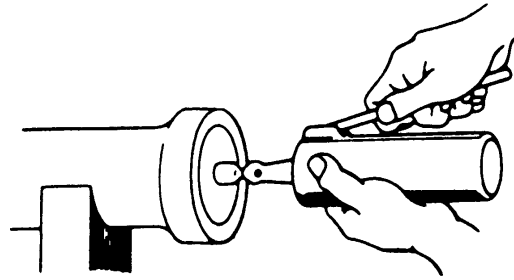

- After reassembly, check all parts for proper tightening and operation.

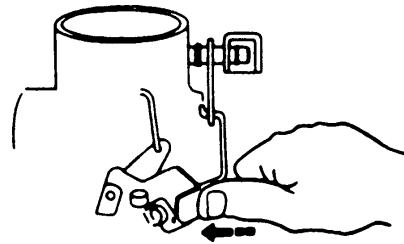

- When two persons work together, pay attention to the mutual working safety.

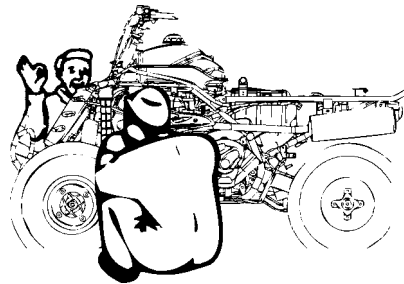

- Disconnect the battery negative (-) terminal before operation.
- When using a spanner or other tools, make sure not to damage the motorcycle surface.

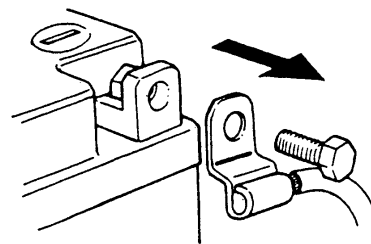

- After operation, check all connecting points, fasteners, and lines for proper connection and installation.
- When connecting the battery, the positive (+) terminal must be connected first.
- After connection, apply grease to the battery terminals.
- Terminal caps shall be installed securely.

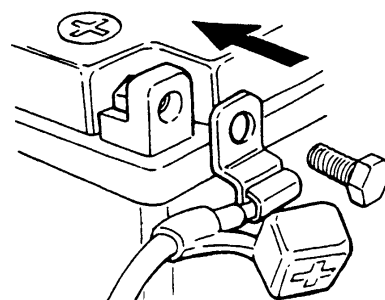

1. GENERAL INFORMATION

- If the fuse is burned out, find the cause and repair it. Replace it with a new one according to the specified capacity.

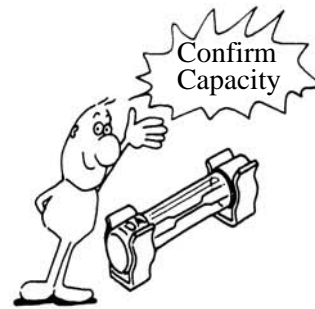

- After operation, terminal caps shall be installed securely.



- When taking out the connector, the lock on the connector shall be released before operation.

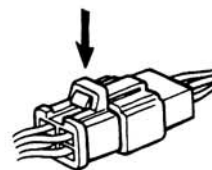

- Hold the connector body when connecting or disconnecting it.
- Do not pull the connector wire.



- Check if any connector terminal is bending, protruding or loose.

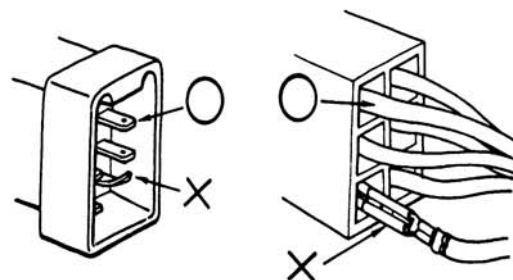

1. GENERAL INFORMATION

- The connector shall be inserted completely.
- If the double connector has a lock, lock it at the correct position.
- Check if there is any loose wire.

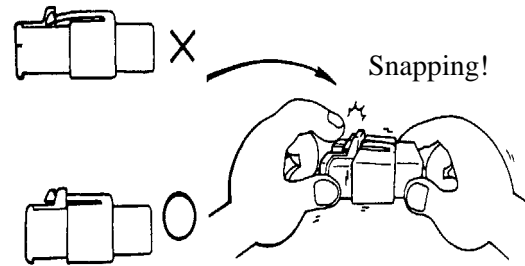

- Before connecting a terminal, check for damaged terminal cover or loose negative terminal.

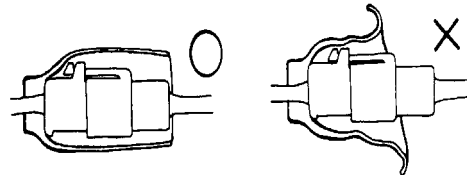

- Check the double connector cover for proper coverage and installation.

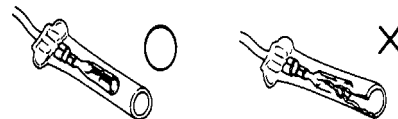

- Insert the terminal completely.
- Check the terminal cover for proper coverage.
- Do not make the terminal cover opening face up.

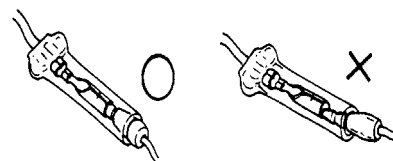

- Secure wire harnesses to the frame with their respective wire bands at the designated locations. Tighten the bands so that only the insulated surfaces contact the wire harnesses.

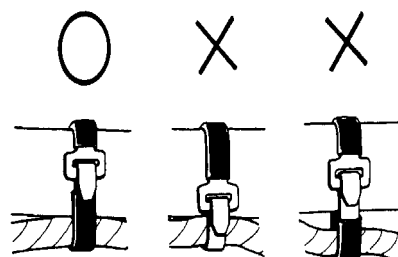

1. GENERAL INFORMATION

- After clamping, check each wire to make sure it is secure.

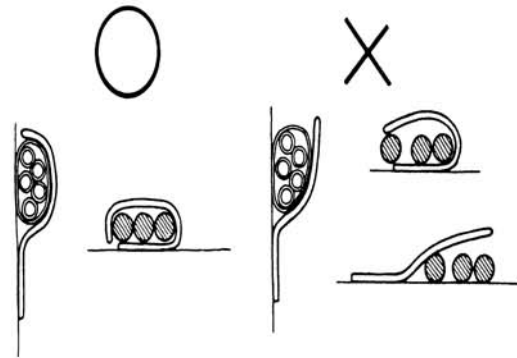

- Do not squeeze wires against the weld or its clamp.



- After clamping, check each harness to make sure that it is not interfering with any moving or sliding parts.

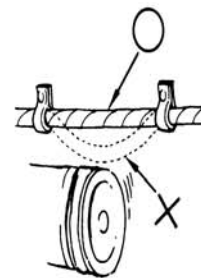

- When fixing the wire harnesses, do not make it contact the parts which will generate high heat.

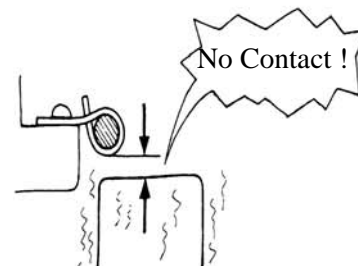

- Route wire harnesses to avoid sharp edges or corners. Avoid the projected ends of bolts and screws.
- Route wire harnesses passing through the side of bolts and screws. Avoid the projected ends of bolts and screws.

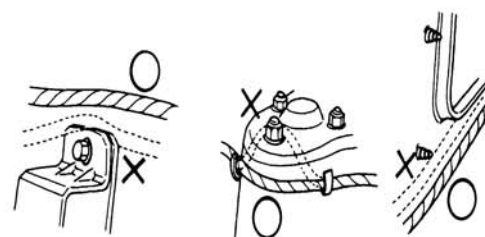

1. GENERAL INFORMATION

- Route harnesses so they are neither pulled tight nor have excessive slack.

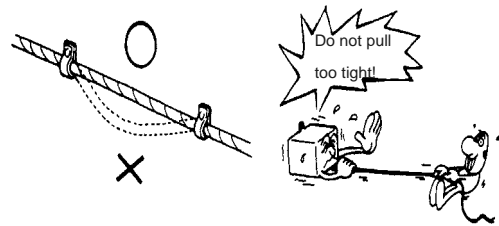

- Protect wires and harnesses with electrical tape or tube if they contact a sharp edge or corner.

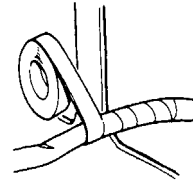

- When rubber protecting cover is used to protect the wire harnesses, it shall be installed securely.

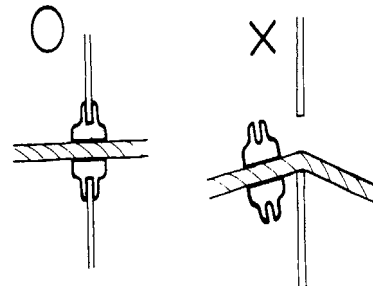

- Do not break the sheath of wire.
- If a wire or harness is with a broken sheath, repair by wrapping it with protective tape or replace it.

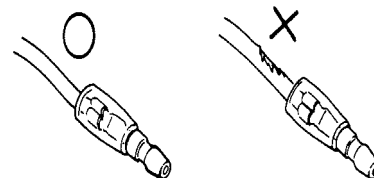

- When installing other parts, do not press or squeeze the wires.

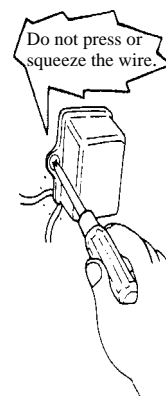

1. GENERAL INFORMATION

- After routing, check that the wire harnesses are not twisted or kinked.

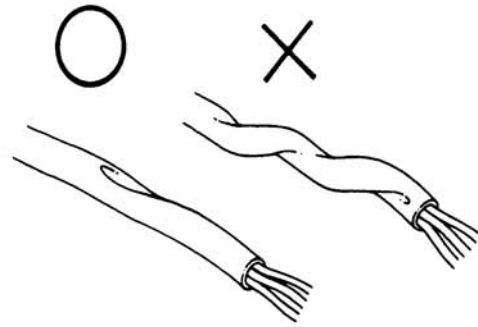

- Wire harnesses routed along with handlebar should not be pulled tight, have excessive slack or interfere with adjacent or surrounding parts in all steering positions.

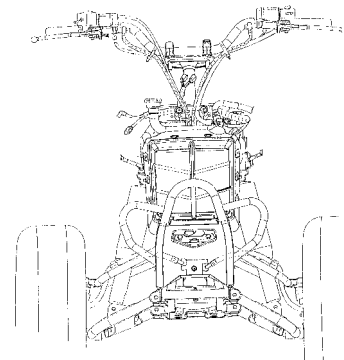

- When a testing device is used, make sure to understand the operating methods thoroughly and operate according to the operating instructions.

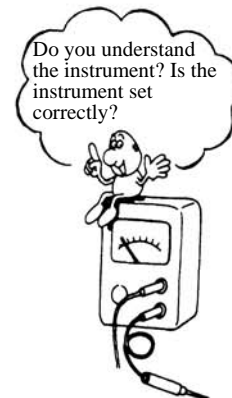

- Be careful not to drop any parts.



- When rust is found on a terminal, remove the rust with sand paper or equivalent before connecting.



1. GENERAL INFORMATION

■ Symbols:

The following symbols represent the servicing methods and cautions included in this service manual.



: Apply engine oil to the specified points. (Use designated engine oil for lubrication.)



: Apply grease for lubrication.



: Transmission Gear Oil (90#)



: Caution



: Warning

1. GENERAL INFORMATION

TORQUE VALUES

STANDARD TORQUE VALUES

Item	Torque kgf-m (N-m, lbf-ft)	Item	Torque kgf-m (N-m, lbf-ft)
5mm bolt and nut	0.5 (5, 3.6)	4mm screw	0.3 (3, 2.2)
6mm bolt and nut	1 (10, 7.2)	5mm screw	0.4 (4, 2.9)
8mm bolt and nut	2.2 (22, 16)	6mm screw, SH bolt	0.9 (9, 6.5)
10mm bolt and nut	3.5 (35, 25)	6mm flange bolt and nut	1.2 (12, 9)
12mm bolt and nut	5.5 (55, 40)	8mm flange bolt and nut	2.7 (27, 20)
14mm bolt and nut	7 (70, 50)	10mm flange bolt and nut	4 (40, 29)

Torque specifications listed below are for important fasteners.

ENGINE

Item	Q'ty	Thread dia. (mm)	Torque kgf-m (N-m, lbf-ft)	Remarks
MAINTENANCE:				
Spark plug	1	10	1.2 (12, 8.6)	
Tappet ADJ nut	4	5	0.9 (9, 6.5)	
Engine oil filter cap	1	30	1.5 (15, 11)	Apply oil
Engine oil filter cartridge	1	20	1 (10, 7.2)	Apply oil
Engine drain plug	1	12	2.5 (25, 18)	
LUBRICATION SYSTEM:				
Oil pump screw	1	4	0.3 (3, 2)	
Oil pipe bolt	2	16	3.5 (35, 25.2)	Apply oil
COOLING SYSTEM:				
Water pump bolt	2	6	1.3 (13, 9)	
Fan motor bolt	4	5	0.53 (5, 2.8)	
Fan motor switch	1	16	1.8 (17, 13)	

(Cont'd)

1. GENERAL INFORMATION

MXU 550EXi/MXU500i

Item	Q'ty	Thread dia. (mm)	Torque kgf-m (N-m, lbf-ft)	Remarks
CYLINDER HEAD:				
Cylinder head bolt	4	10	4.8 (48, 34.6)	Apply oil
Cylinder head bolt	9	8	2.3 (23, 17)	Apply oil
Cylinder head nut	2	6	1 (10, 7)	
Cylinder head cover	4	6	1 (10, 7)	
Breather separator bolt	3	6	1.3 (13, 9)	
Cam chain tensioner bolt	2	6	1.2 (12, 8.6)	
Tensioner sealing bolt	1	10	1 (10, 7)	
Rocker arm shaft	2	18	4.5 (45, 32.4)	Apply oil
Chain guide pivot bolt	2	8	2 (20, 15)	
Water joint bolt	2	6	1.2 (12, 8.6)	
CYLINDER:				
Cylinder bolt	2	6	1 (10, 7.2)	
DRIVE/DRIVEN PULLEY:				
Drive pulley nut	1	20	14 (140, 100.8)	Apply oil
Wet clutch nut	1	25	14 (140, 100.8)	
Driven pulley nut	1	16	10 (100, 72)	Apply oil
Driven pulley assembly plate nut	1	36	7.5 (75, 54)	
TRANSMISSION:				
Crankcase bolt	19	6	1.2 (12, 8.6)	Apply oil
Drive bevel gear nut	1	20	14 (140, 100.8)	Apply oil
Driven bevel gear nut	1	20	14 (140, 100.8)	Apply oil
Stopper lever bolt	1	8	2.5 (25, 18)	
Stopper lever boss nut	1	12	3 (30, 21.6)	
Shift came stopper plug	1	20	4.8 (48, 35)	
Output shaft bearing nut	1	85	11 (110, 79.2)	Apply oil
Drive shaft bearing bolt	4	8	3 (30, 21.6)	
STARTER SYSTEM:				
Starter pulley nut	1	14	5.5 (55, 40)	

1. GENERAL INFORMATION

TORQUE VALUES

FRAME

Item	Q'ty	Thread dia. (mm)	Torque Kgf-m (N-m, lbf-ft)	Remarks
MAINTENANCE:				
Rear drive gear oil drain bolt	1	8	2 (20, 15)	
Rear drive gear oil filler cap	1	30	1.5 (15, 11)	
Rear drive gear oil level check bolt	1	8	2 (20, 15)	
Front drive gear oil drain bolt	1	14	3.2 (32, 23)	
Front drive gear oil filler cap	1	18	3.5 (35, 25.5)	
Front drive gear oil level check bolt	1	6	1 (10, 7.2)	
Tie-rod adjusting nut	4	10	3.5 (35, 25.5)	
Front wheel hub nut	2	18	7 (70, 50)	Castle nut
Rear wheel hub nut	2	16	10 (100, 72)	Castle nut
EXHAUST MUFFLER:				
Exhaust muffler mounting bolt	2	8	3.5 (35, 25)	
Exhaust pipe mounting nut	2	8	3.5 (35, 25)	
Exhaust muffler band bolt	1	8	2.1 (21, 15)	
ENGINE ASSEMBLY:				
Engine mounting bolt/nut	3	10	6 (60, 43.5)	
Engine hanger nut	4	8	3.5 (35, 25)	
DRIVE TRAIN:				
Front drive:				
Front propeller shaft bolt	3	10	4.5 (45, 32.4)	
Front drive gear case mounting bolt	2	10	4 (40, 29)	Apply threebond: 1215
Shifting fork shaft plug	1	8	1.5 (15, 11)	Apply threebond: 1215
Front drive gear case bolt	9	8	2.3 (23, 16.5)	Apply threebond: 1215
2WD/4WD shift motor mounting bolt	1	8	2.3 (23, 16.5)	
2WD/4WD shift motor mounting bolt	2	6	1.2 (12, 8.5)	
Rear drive:				
Rear drive gear case mounting nut	8	10	5.5 (55, 40)	Apply threebond: 1215
Rear drive gear case bolt	2	10	5 (49, 36)	Apply threebond: 1215
Rear drive gear case bolt	6	8	2.5 (25, 19)	

(Cont'd)

1. GENERAL INFORMATION

MXU 550EXi/MXU500i

Item	Q'ty	Thread dia. (mm)	Torque Kgf-m (N-m, lbf-ft)	Remarks
STEERING :				
Handlebar and holder post		10	2.7 (27, 19)	
Upper/lower housing and frame		8	2.7 (27, 19)	
Steering knuckle and tie-rod		10	4.2 (42, 30)	
Steering stem and tie-rod		10	4.2 (42, 30)	
Tie-rod lock nut		10	2.5 (25, 18)	
Steering post lower pivot		10	5.5 (55, 40)	
Bearing flange and frame		10	6.5 (65, 46)	
WHEEL:				
Front/rear wheel and hub		10	6.1 (61, 44)	
Front wheel hub and front halfshaft(CVJ)		22	28 (280, 202)	Castle nut
Rear wheel hub and rear halfshaft(CVJ)		22	28 (280, 202)	Castle nut
Front wheel hub and stud axle(2WD only)		22	28 (280, 202)	Castle nut
SUSPENSION:				
Front:				
Front shock upper joint and frame		10	4.8 (48, 35)	
Front upper arm and frame		10	4.8 (48, 35)	
Front lower arm and frame		10	4.8 (48, 35)	
Front shock joint and front upper arm		10	4.8 (48, 35)	
Front shock joint and front lower arm		10	4.8 (48, 35)	
Rear:				
Rear shock upper joint and frame		10	4.8 (48, 35)	
Rear upper arm and frame		10	4.8 (48, 35)	
Rear lower arm and frame		10	4.8 (48, 35)	
Rear shock joint and rear upper arm		10	4.8 (48, 35)	
Rear shock joint and rear lower arm		10	4.8 (48, 35)	
Stabilizer and frame		8	2.7 (27, 19)	
Stabilizer joint and stabilizer		10	5.5 (55, 40)	
Stabilizer joint and rear lower arm		10	5.5 (55, 40)	
BRAKE SYSTEM:				
Front brake disc and front hub		6	2.0(20, 14)	
Rear brake disc and rear hub		8	3.5(35, 25)	
Brake hose oil bolt		10	3.5(35, 25)	
Master cylinder holder bolt		6	1.2(12, 7)	
Secondary master cylinder holder and frame		6	1.2(12, 7)	







1. GENERAL INFORMATION

Front caliper and knuckle	8	2.7 (27, 19)	
Rear caliper and bracket	8	2.7 (27, 19)	
Master cylinder cap screw	4	0.15(1.5, 1.1)	
Brake caliper bleed valve	8	0.55(5.5, 4.0)	
Brake pedal adjusting nut	6	0.9 (9, 6.5)	
Rear disc holder and gear box	10	4.5(45, 34)	
FRAME			
Exhaust pipe and head	8	2.0(20, 14)	
Muffler bracket and frame	10	3.5(35, 25)	
Upper engine nut	10	6.0 (60, 43)	
Front and rear lower engine nut	10	6.0 (60, 43)	
Lower engine hanger	8	2.7 (27, 19)	
Shift rod	8	2.7 (27, 19)	
Front gear case and frame	10	5.3 (53, 38)	
Rear gear case and frame	10	5.3 (53, 38)	
Thermo switch ASSY	16	2.2 (22, 16)	
Set start MAG		0.3 (3, 2)	

1. GENERAL INFORMATION

MXU 550EXi/MXU500i

SPECIAL TOOLS

Tool Name	Tool No.	Illustration (Note: the special tools may differ slightly from those shown in the figure of this manual.)
Oil seal and bearing installer	A120E00014	
Valve adjuster(T tape) (Refer to the “VALVE CLEARANCE” section in the chapter 3.)	A120E00080	
Bearing puller	A120E00037	
Valve spring compressor (Refer to the “CYLINDER HEAD DISASSEMBLY/INSPECTION/ASSEMBLY” section in the chapter 8.)	A120E00040	
Universal holder (Refer to the “DRIVE PULLEY, DRIVE V-BELT AND DRIVEN PULLEYREMOVAL/INSPECTION/INSTALLATION” section and “CLUTCH REMOVAL/INSTALLATION” section in the chapter 10.)	A120E00056	
Drive pulley holder (Refer to the “DRIVE PULLEY, DRIVE V-BELT AND DRIVEN PULLEYREMOVAL/INSPECTION/INSTALLATION” section in the chapter 10.)	A120E00058	

1. GENERAL INFORMATION

Tool Name	Tool No.	Illustration (Note: the special tools may differ slightly from those shown in the figure of this manual.)
Cluth Spring Compressor Fittings 46mm HEX) (Refer to the “ DRIVEN PULLEY DISASSEMBLY/INSPECTION/ASSEMBLY ” section in the chapter	A120E00057	
Flywheel puller (Refer to the “ STARTER CLUTCH REMOVAL/INSPECTION/INSTALLATION ” section in the chapter 19.)	A120E00060	
Oil filter cartridge wrench 67mm (Refer to the “(Refer to the “ ENGINE OIL ” section in the chapter 3.)	A120E00052	
Output shaft bearing nut wrench (Refer to the “(Refer to the “ BEARING REPLACEMENT IN THE RIGHT CRANKCASE ” section in the chapter 11.)	A120E00066	
Crankshaft bearing puller	A120E00068	
LOCK NUT WRENCH	A120E00079	

1. GENERAL INFORMATION

MXU 550EXi/MXU500i

Tool Name	Tool No.	Illustration (Note: the special tools may differ slightly from those shown in the figure of this manual.)
CLUTCH SPRING COMPRESSOR	A120E00053	
Drive shaft puller (Refer to the “ FRONT DRIVE SHAFT REOMVAL/ INSPECTION/ ”	A120F00017	
Pinion bearing lock nut wrench (Refer to the “ REAR DRIVE DISASSEMBLY/INSPECTION/ ASSEMBLY ” section in the chapter 13.)	A120F00020	
LOCK NUT WRENCH M54 x 15 With 6 angle	A120F00025	
PINION GEAR PULLER	A120F00026	
BEARING PULLER	A120F00027	

1. GENERAL INFORMATION

LUBRICATION POINTS

ENGINE

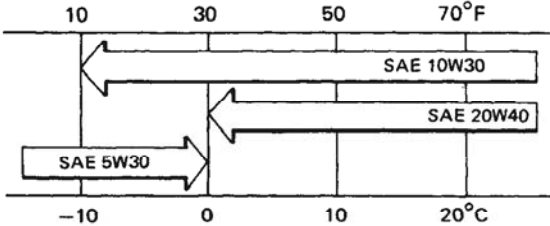
Lubrication Points	Lubricant
Valve guide/valve stem movable part Camshaft protruding surface Valve rocker arm friction surface Camshaft drive chain Cylinder lock bolt Piston surroundings and piston ring grooves Piston pin surroundings Cylinder inside wall Connecting rod/piston pin hole Connecting rod big end Clutch Crankshaft Balance shaft Crankshaft one-way clutch movable part Recoil starter pulley Oil pump drive chain Starter reduction gear Starter one-way clutch O-ring face Oil seal lip Output shaft Bevel gear Drive shaft Countershaft Main shaft Transmission gear shaft bearing part	<ul style="list-style-type: none"> •Genuine KYMCO Engine Oil (SAE5W-50) •API SJ Engine Oil 
Front drive gear and bearing part	Gear oil: SAE 90#
Rear drive gear and bearing part	Gear oil: SAE 80#

1. GENERAL INFORMATION

FRAME

The following is the lubrication points for the frame.

Use general purpose grease for parts not listed.

Apply clean engine oil or grease to cables and movable parts not specified. This will avoid abnormal noise and rise the durability of the ATV.

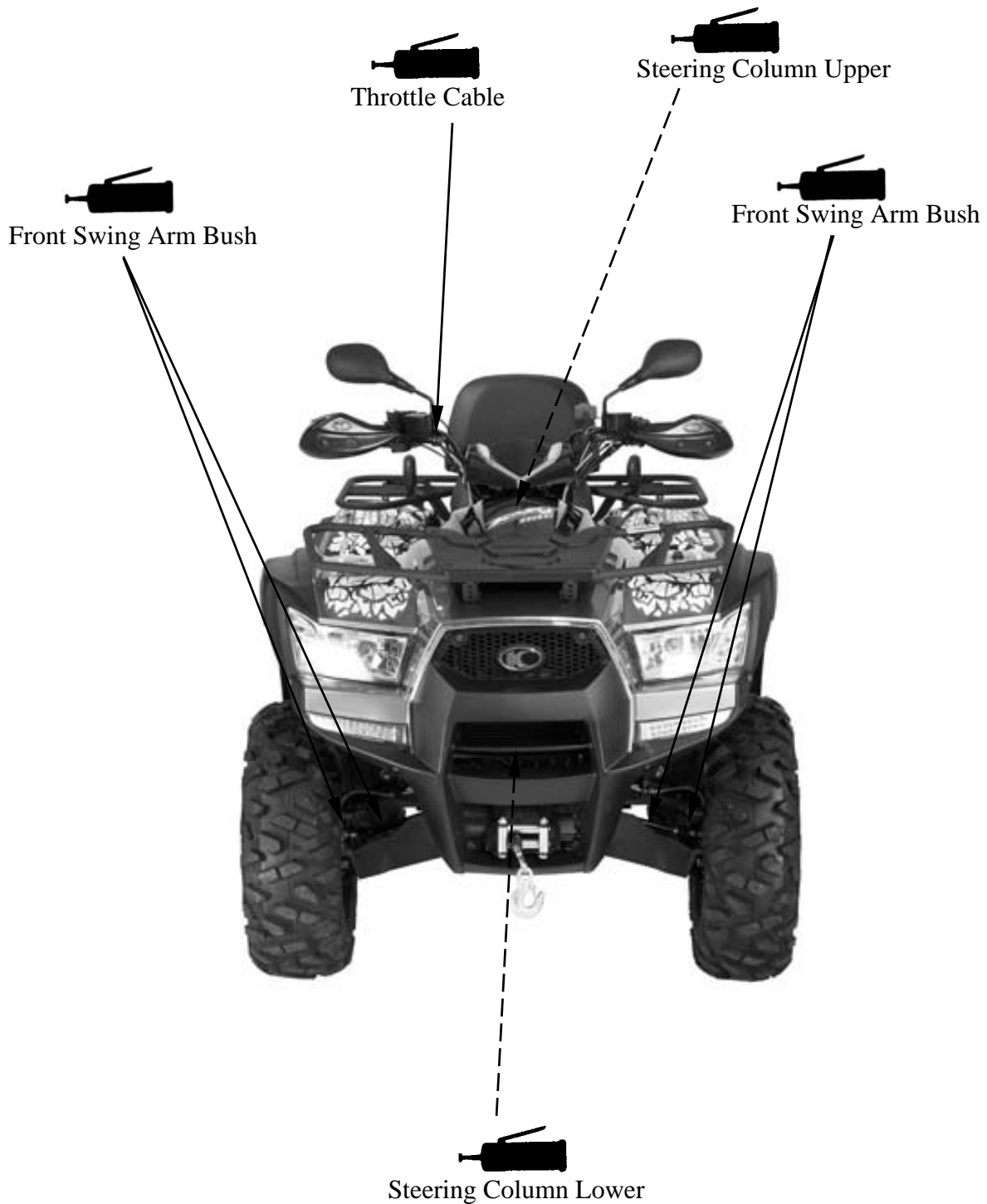

FRAME COVERS/EXHAUST MUFFLER

SERVICE INFORMATION-----	2- 2
TROUBLESHOOTING-----	2- 2
FASTENER REMOVAL AND REINSTALLATION-----	2- 3
FRAME COVERS-----	2- 4
EXHAUST MUFFLER -----	2-13

2. FRAME COVERS/EXHAUST MUFFLER MXU550EXi/MXU500i

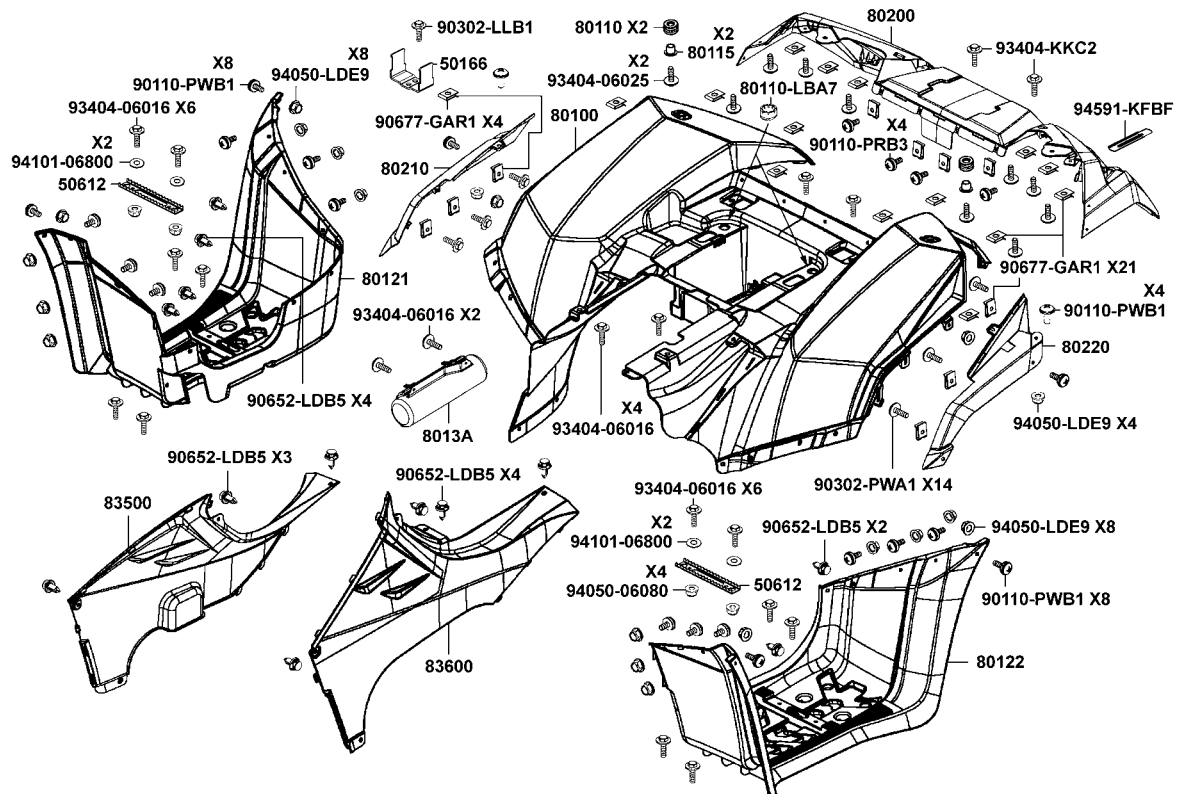
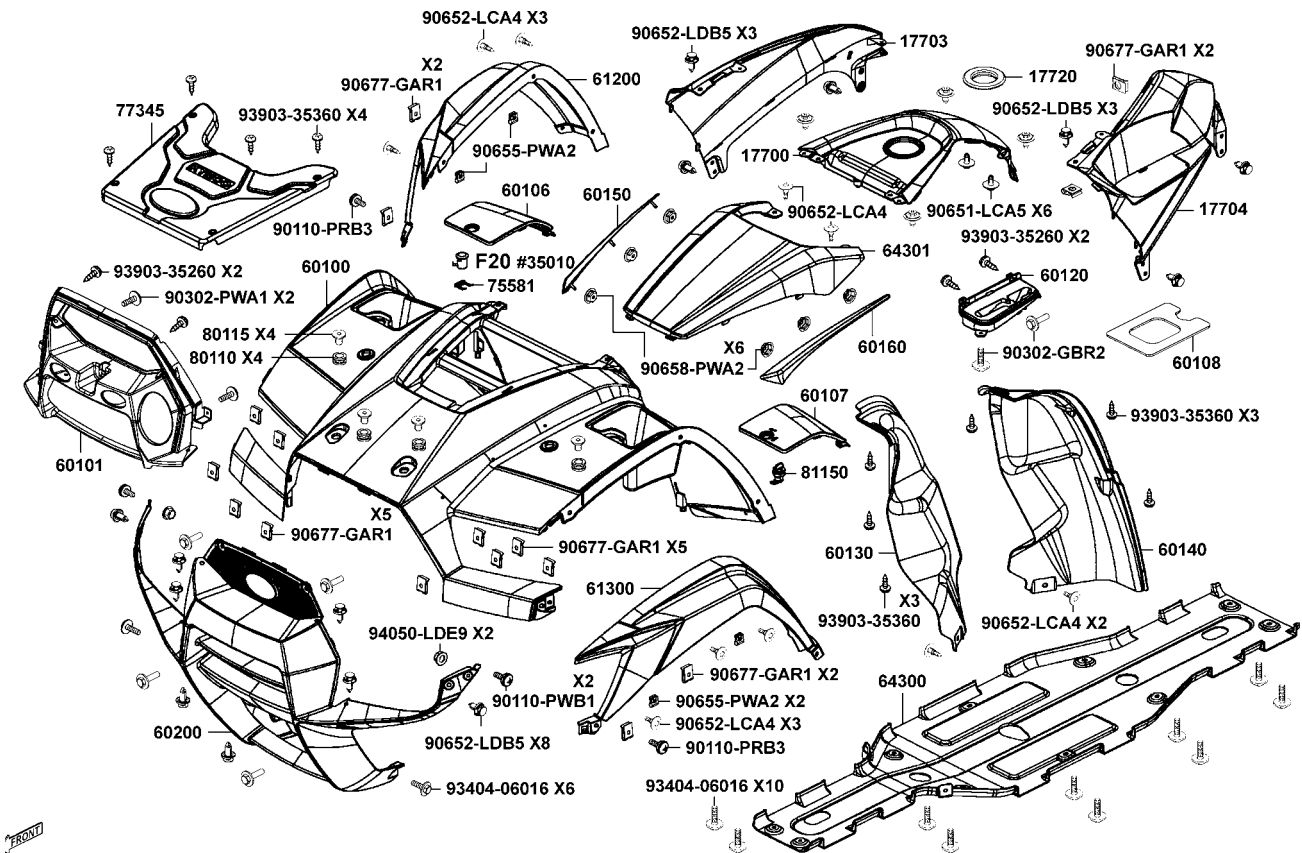

2. FRAME COVERS/EXHAUST MUFFLER MXU550EXi/MXU500i

SERVICE INFORMATION

GENERAL INSTRUCTIONS

- When removing frame covers, use special care not to pull them by force because the cover joint claws may be damaged.
- Make sure to route cables and harnesses according to the Cable & Harness Routing.

TORQUE VALUES

Exhaust pipe and head (nut)	2.0 kgf-m (20N-m; 14 lbf-ft)
Muffler bracket and frame(bolt)	.3.5 kgf-m (35N-m; 25 lbf-ft)
Exhaust muffler band bolts	2.1 kgf-m (21N-m; 15 lbf-ft)

TROUBLESHOOTING

Noisy exhaust muffler

- Damaged exhaust muffler
- Exhaust muffler joint air leaks

Lack of power

- Caved exhaust muffler
- Exhaust muffler air leaks
- Clogged exhaust muffler

2. FRAME COVERS/EXHAUST MUFFLER MXU550EXi/MXU500i

FASTENER REMOVAL AND REINSTALLATION

REMOVAL

Depress the head of fastener center piece ①.
Pull out the fastener.

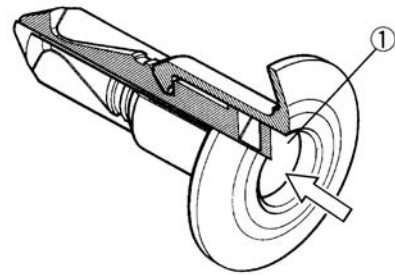

INSTALLATION

Let the center piece stick out toward the head so that the pawls ② close.
Insert the fastener into the installation hole.

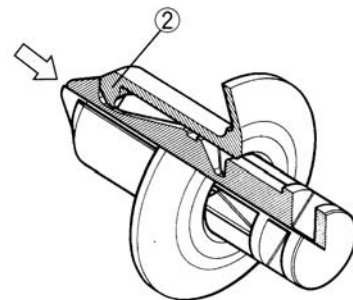

* To prevent the pawl ② from damage, insert the fastener all the way into the installation hole

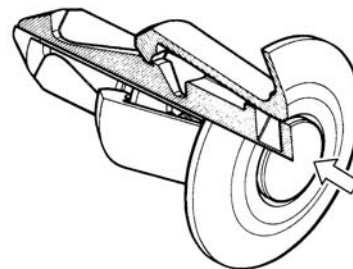

Push in the head of center piece until it becomes flush with the fastener outside face.

Up position function is disconnect (need use screwdriver)

Down position function is lock.



2. FRAME COVERS/EXHAUST MUFFLER MXU550EXi/MXU500i

FRAME COVERS

SEAT

REMOVAL

To remove the seat, pull the seat lock lever upward and pull up the seat at the rear.

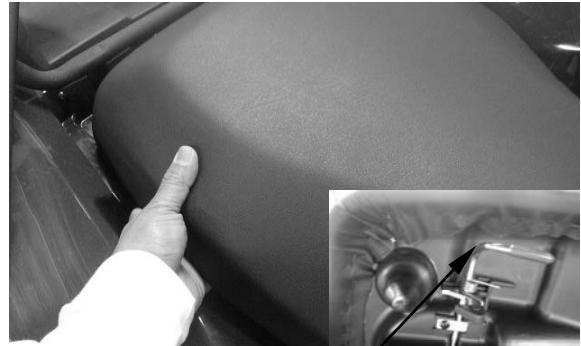

Lever

INSTALLATION

To install the seat, align the tabs on the seat with the grommets on the frame and press the seat down until it locks.

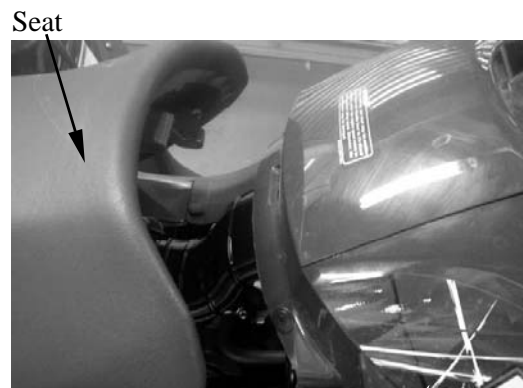

FRONT CARGO RACK

REMOVAL/INSTALLATION

First remove cargo's cover then remove four bolts of side upper front fender. .

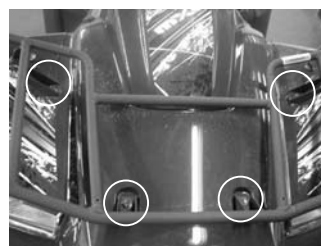
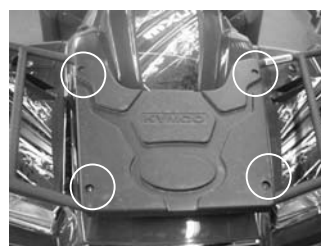

2. FRAME COVERS/EXHAUST MUFFLER MXU550EXi/MXU500i

FRONT CARRIER COVER

REMOVAL/INSTALLATION

Remove mounting bolts and screws with fastener then to separate the front carrier cover.

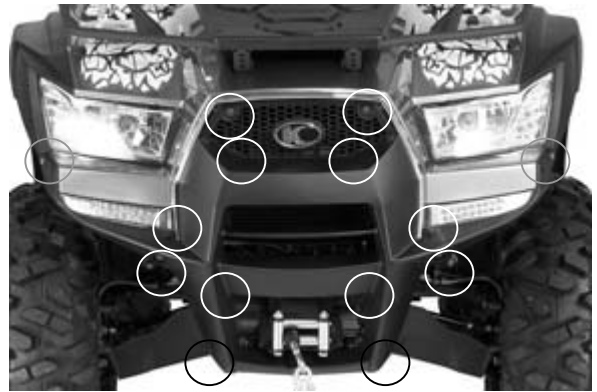

2. FRAME COVERS/EXHAUST MUFFLER MXU550EXi/MXU500i

GUARD R/L BOOT

REMOVAL/INSTALLATION

Remove the one bolts from the guard boot, then remove the guard boot,.

Installation is in the reverse order of removal.

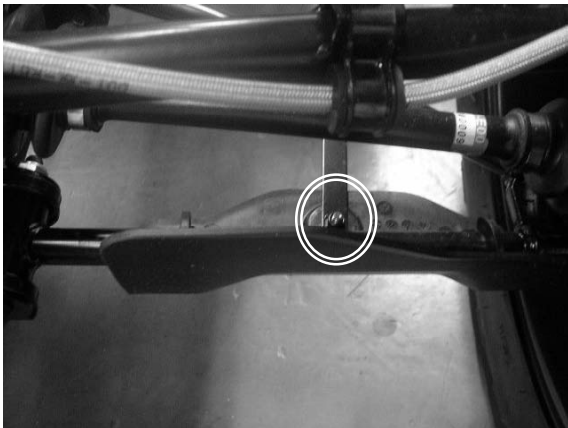

REAR CARGO RACK

REMOVAL/INSTALLATION

Remove the four mounting bolts from the rear cargo rack right/left side under rear fender.

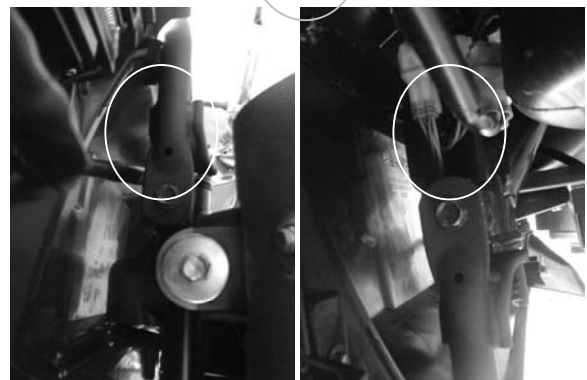

2. FRAME COVERS/EXHAUST MUFFLER MXU550EXi/MXU500i

Remove six bolts from the rear cargo rack.

Installation is in the reverse order of removal.

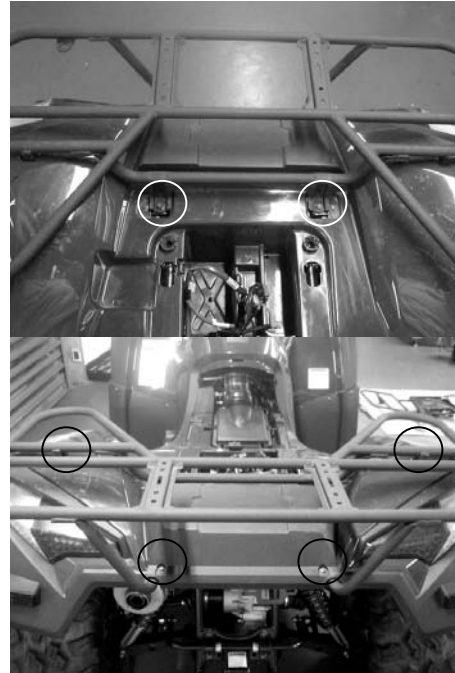

RIGHT/LEFT FOOTBOARD

REMOVAL/INSTALLATION

Remove the four fasteners, eight screws/nuts and four bolts, then remove the right foot board.

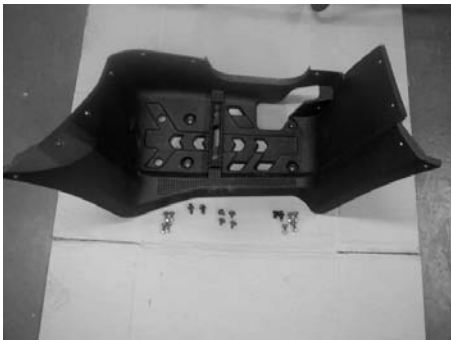

Remove the two fasteners, eight screws/nuts and four bolts, then remove the left footboard.

* During removal, do not pull the joint claws forcedly to avoid damage.

Installation is in the reverse order of removal.

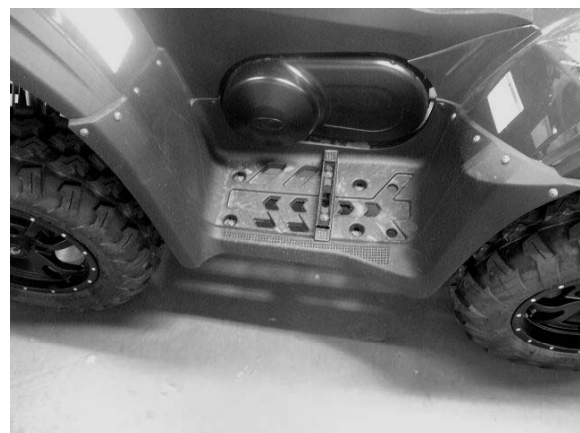

2. FRAME COVERS/EXHAUST MUFFLER MXU550EXi/MXU500i

RIGHT/LEFT SIDE COVER

REMOVAL/INSTALLATION

Remove the seat (page 2-4) and right or left footboard. (see page 2-7).

Remove screws and fasteners, then remove the right or left side cover.

* During removal, do not pull the joint claws forcedly to avoid damage.

Installation is in the reverse order of removal.



FRONT CENTER COVER

REMOVAL/INSTALLATION

Remove the two fasteners and then remove front cover.

* During removal, do not pull the joint claws forcedly to avoid damage.

Installation is in the reverse order of removal.

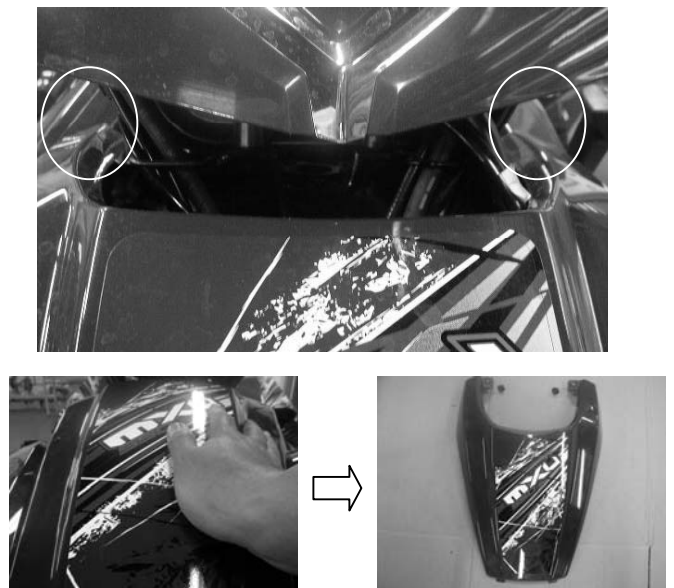

METER COVER

REMOVAL/INSTALLATION

Remove the two screws from the meter cover.

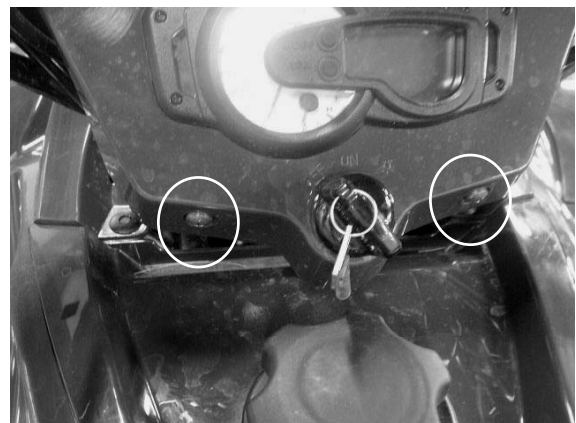

2. FRAME COVERS/EXHAUST MUFFLER MXU550EXi/MXU500i

Disconnect the ignition switch, instrument connectors, then remove the meter cover.

Installation is in the reverse order of removal.



FUEL TANK COVER

REMOVAL/INSTALLATION

Remove the seat (page 2-4), front center cover (page 2-8), right/left footboards (page 2-7) and right/left side covers (page 2-8).

Remove a bolt and then remove drive select grip.

Remove fasteners from fuel tank cover left side.

Drive Select Grip



Remove the two fasteners from fuel tank cover right side.

Remove the two fasteners from fuel tank cover front side.

Remove the fuel tank cap by turning it counterclockwise and fuel tank seal, then remove the fuel tank cover.



* Put on the fuel tank cap after removing the cover to prevent duct, mud, etc. from entering the fuel tank.

Installation is in the reverse order of removal.



2. FRAME COVERS/EXHAUST MUFFLER MXU550EXi/MXU500i

FRONT FENDER

REMOVAL/INSTALLATION

Remove the seat (page 2-4), front cargo rack (page 2-5), front carrier (page 2-6), front center cover (page 2-8), right/left footboards (page 2-7), right/left side covers (page 2-8) and fuel tank cover (page 2-9).

Disconnect the right/left turn signal light connectors (ON ROAD) and headlight connectors.

Disconnect the DC 12V power socket Connectors.

Remove the two fasteners from front fender right and left side front fender, then remove the front fender.

Installation is in the reverse order of removal.

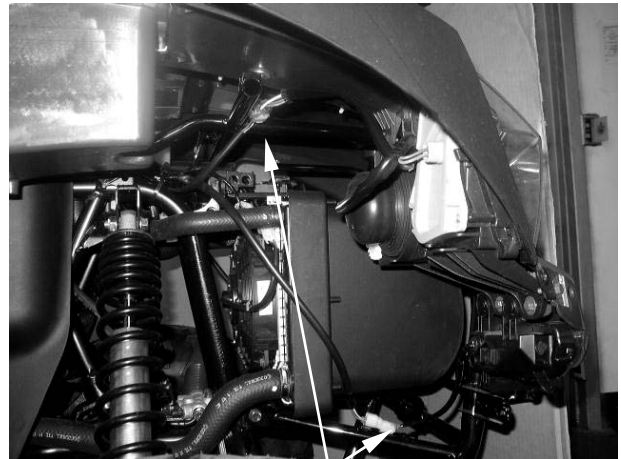

Turn Signal Lights/Headlights Connectors.

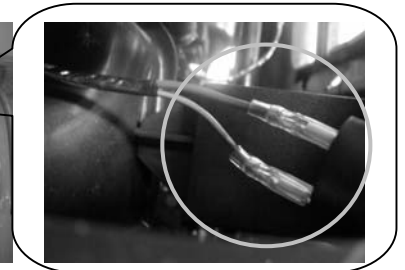

DC12V power socket connectors.



REAR FENDER

REMOVAL/INSTALLATION

Remove the seat (page 2-4), rear cargo rack (page 2-6), right/left footboards (page 2-7) and right/left side covers (page 2-8).

Disconnect the right and left taillight/brake light/turn signal light connectors (ON ROAD).

Disconnect the right and left taillight/brake light connectors (OFF ROAD).

Turn Signal Lights/Taillights Connectors

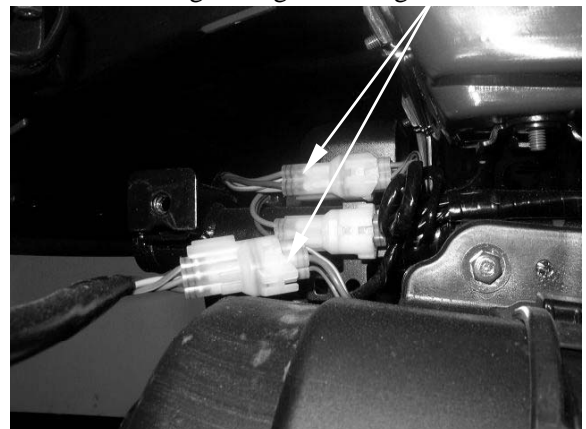

2. FRAME COVERS/EXHAUST MUFFLER MXU550EXi/MXU500i

Remove the starter relays and other relays.

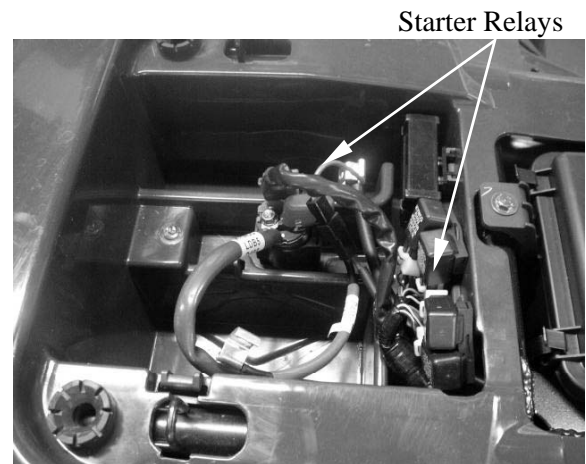

Push the lock clip under rear fender by finger and remove the fuse box.

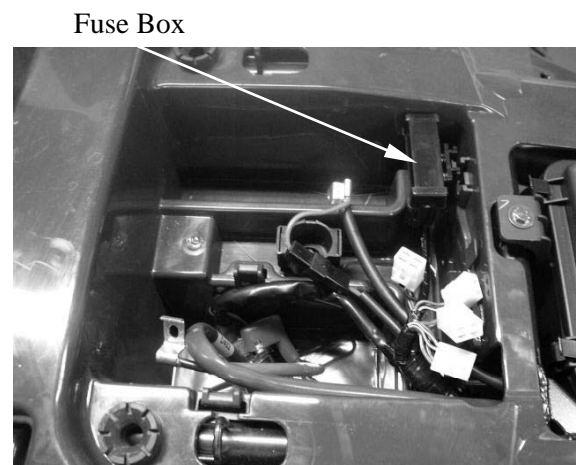

Remove the four mounting bolts from the rear fender, then remove the rear fender.

Installation is in the reverse order of removal.

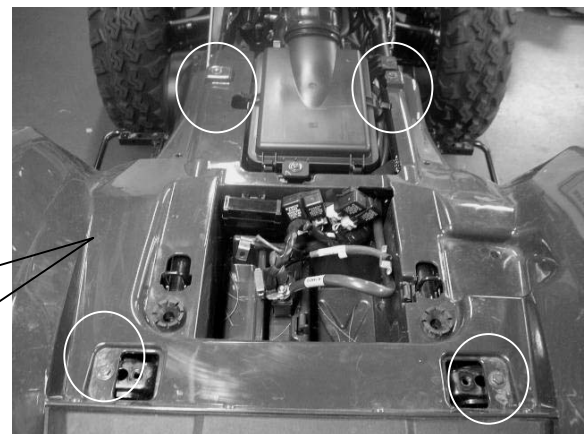
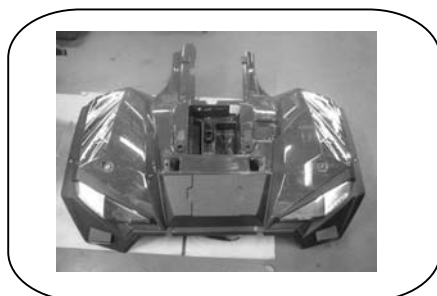

2. FRAME COVERS/EXHAUST MUFFLER MXU550EXi/MXU500i

BOTTOM COVER

REMOVAL/INSTALLATION

Remove the mounting bolts from bottom cover side, then remove bottom cover.

Installation is in the reverse order of removal.

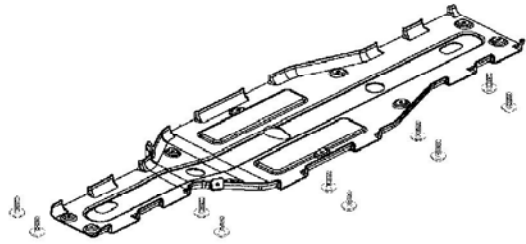

2. FRAME COVERS/EXHAUST MUFFLER MXU550EXi/MXU500i

EXHAUST MUFFLER

REMOVAL

Loosen the exhaust pipe band bolt.
Remove two muffler mounting bolts.

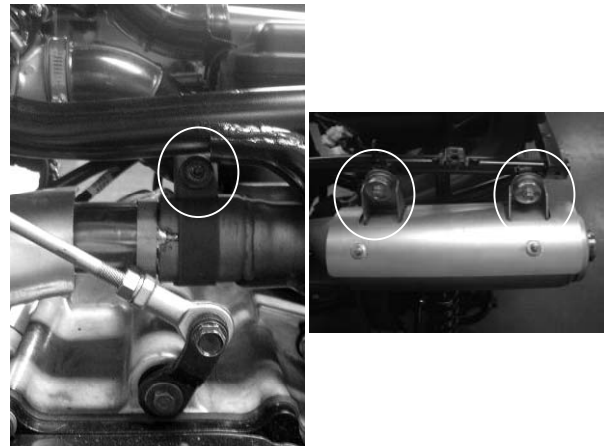

Remove the muffler and gasket from the
exhaust pipe

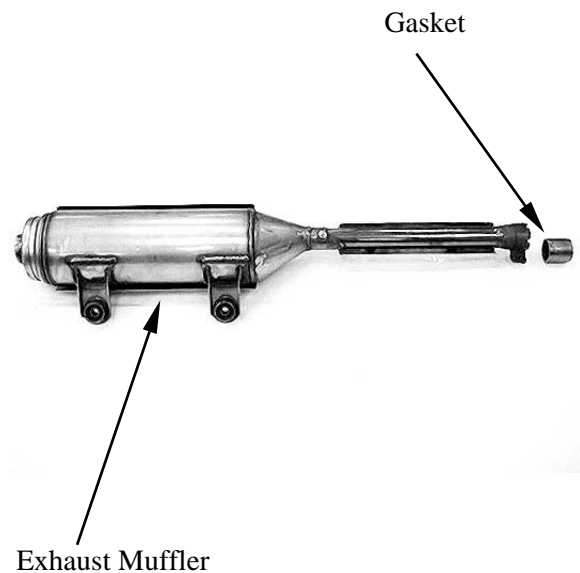

Remove the exhaust pipe joint nuts.

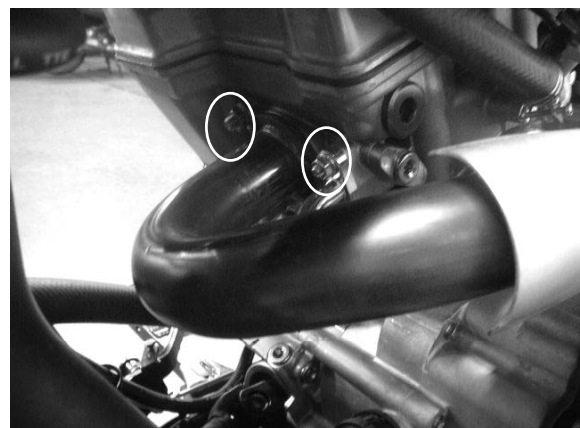

2. FRAME COVERS/EXHAUST MUFFLER MXU550EXi/MXU500i

Remove the exhaust pipe and gasket.

INSTALLATION

Replace the gaskets with new ones.
Install the exhaust pipe and tighten the joint nuts.

Torque:

Exhaust pipe and head (nut):

2.0 kgf-m (20 N-m; 14 lbf-ft)

Install the muffler and tighten the mounting bolts.

Torque:

Muffler bracket and frame(bolt):

3.5 kgf-m (35 N-m; 25 lbf-ft)

Install and tighten the band bolts.

Torque: 2.1 kgf-m (21 N-m; 15 lbf-ft)

* Be sure to install a new exhaust gasket.

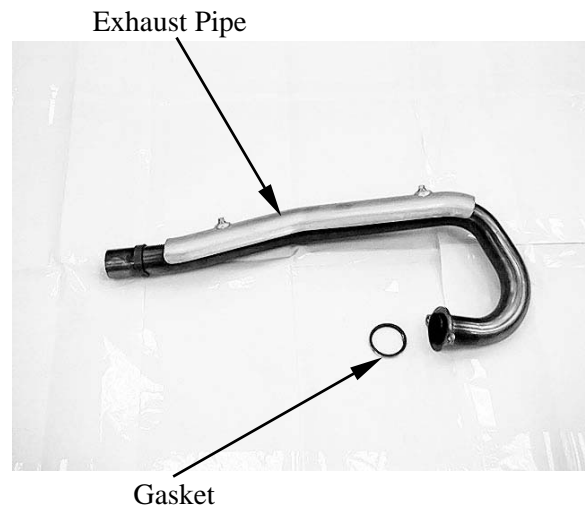

INSPECTION/ADJUSTMENT

SERVICE INFORMATION-----	3- 1
MAINTENANCE SCHEDULE-----	3- 3
FUEL LINE/THROTTLE OPERATION-----	3- 4
SPEED LIMITER/AIR CLEANER-----	3- 5
AIR FILTER FOR DRIVE BELT-----	3- 7
SPARK PLUG-----	3- 8
VALVE CLEARANCE-----	3-10
CARBURETOR IDLE SPEED-----	3-11
CLINDER COMPRESSION/ENGINE OIL-----	3-12
REAR GEAR BOX OIL-----	3-16
FRONT GEAR BOX OIL-----	3-17
SPARK ARRESTER-----	3-18
DRIVE SHAFT BOOTS-----	3-19
DRIVE BELT/BRAKE PADS INSPECTION-----	3-20
BRAKE FLUID INSPECTION/HEADLIGHT AIM-----	3-21
STEERING SYSTEM INSPECTION-----	3-22
TOE-IN ADJUSTMENT-----	3-23
WHEELS/TIRES-----	3-24
FRONT SHOCK ABSORBER/REAR SHOCK ABSORBER/ DRIVE SELECT LEVER ADJUSTMENT-----	3-26
CABLE INSPECTION AND LUBRICATION/ADJUSTING THE REAR BRAKE LIGHT SWITCH (BRAKE PEDAL)-----	3-28
COOLING SYSTEM-----	3-29
PARKING BRAKE ADJUSTMENT(ON ROAD ONLY)-----	3-31

3. INSPECTION/ADJUSTMENT

SERVICE INFORMATION

GENERAL

 **WARNING**

- Before running the engine, make sure that the working area is well-ventilated. Never run the engine in a closed area. The exhaust contains poisonous carbon monoxide gas which may cause death to people.
- Gasoline is extremely flammable and is explosive under some conditions. The working area must be well-ventilated and do not smoke or allow flames or sparks near the working area or fuel storage area.

SPECIFICATIONS

Throttle grip free play : 3~5 mm

Spark plug gap : 0.6~0.7 mm

Spark plug: Standard: CR7E (NGK)

Valve clearance : IN: 0.1 mm
EX: 0.1 mm

Idle speed : 1400±100 rpm

Engine oil capacity

At disassembly : 3.6 liter

At change : 3.0 liter

Front gear box oil

Recommended oil: SAE 80

At disassembly: 270 cc

At change: 250 cc

Rear gear box oil

Recommended oil: SAE 80

At disassembly: 250 cc

At change: 230 cc

Cylinder compression: 15 kg/cm²

Ignition timing: 12°/IDLE

3. INSPECTION/ADJUSTMENT

Tire pressure

ON ROAD	1 Rider
Front	0.38kgf/cm ² (38Kpa, 5.5psi)
Rear	0.35 kgf/cm ² (35Kpa, 5.0psi)
OFF ROAD	1 Rider
Front	0.35kgf/cm ² (35Kpa, 5.0psi)
Rear	0.32 kgf/cm ² (32Kpa, 4.5psi)

Tire size:

Front : 25X8-12

Rear : 25X10-12—**OFF ROAD**

Front : 26X8-14

Rear : 26X10-14—**ON ROAD**

TORQUE VALUES

Spark plug	1.2 kgf-m (12N-m)
Tappet ADJ nut	0.9 kgf-m (9 N-m)
Engine oil filter	1.0 kgf-m (10N-m)
Engine oil drain plug	2.5 kgf-m (25 N-m)
Tie-rod lock nut	2.5 kgf-m (25 N-m)
Front wheel hub nut	6.1 kgf-m (61 N-m)
Rear wheel hub nut	6.1 kgf-m (61 N-m)

SPECIAL TOOLS

Valve adjusting wrench **A120E00080**

Oil cartridge wrench **A120E00052**

3. INSPECTION/ADJUSTMENT

MAINTENANCE SCHEDULE

This chapter includes all information necessary to perform recommended inspections and adjustments. These preventive maintenance procedures, if followed, will ensure more reliable vehicle operation and a longer service life. The need for costly overhaul work will be greatly reduced. This information applies to vehicles already in service as well as new vehicles that are being prepared for sale. All service technicians should be familiar with this entire chapter.

ITEM	WHICHEVER COMES FIRST ROUTINE	INITIAL		EVERY	
		mi	100	600	1200
		Km	150	1000	2000
		MONTH	1	6	12
Engine oil	•Replace (Warm engine before draining).		<input type="radio"/>	<input type="radio"/>	<input type="radio"/>
*Oil strainer	•Clean. •Replace if necessary.		<input type="radio"/>	<input type="radio"/>	<input type="radio"/>
Engine oil filter cartridge	•Replace		<input type="radio"/>	<input type="radio"/>	<input type="radio"/>
Final gear oil	•Check oil level/oil leakage •Replace every 12 months.		<input type="radio"/>		<input type="radio"/>
Differential gear oil	•Check oil level/oil leakage •Replace every 12 months.		<input type="radio"/>		<input type="radio"/>
Air filter element (for engine and *V-belt compartment)	•Clean. (More often in wet or dusty areas.) •Replace if necessary.			<input type="radio"/>	<input type="radio"/>
*Throttle body	•Check idle speed/starter operation. •Adjust if necessary.				<input type="radio"/>
*Cylinder head cover breather system	•Check breather hose for cracks or damage. •Replace if necessary.			<input type="radio"/>	<input type="radio"/>
Spark plug	•Check condition. •Adjust gap and clean. •Replace if necessary.		<input type="radio"/>	<input type="radio"/>	<input type="radio"/>
*Fuel line	•Check fuel hose for cracks or damage. •Replace if necessary.			<input type="radio"/>	<input type="radio"/>
*Valves	•Check valve clearance. •Adjust if necessary.		<input type="radio"/>	<input type="radio"/>	<input type="radio"/>

ITEM	WHICHEVER COMES FIRST ROUTINE	INITIAL		EVERY	
		mi	100	600	1200
		Km	150	1000	2000
		MONTH	1	6	12
*Brake	•Check operation and brake fluid. •Replace brake pad if necessary.		<input type="radio"/>	<input type="radio"/>	<input type="radio"/>
*Coolant	•Check coolant leakage. •Replace if necessary. •Replace coolant every 24 months.		<input type="radio"/>	<input type="radio"/>	<input type="radio"/>
*V-belt	•Check operation. •Replace if damage or excessive wear.		<input type="radio"/>		<input type="radio"/>
*Exhaust system	•Check leakage. •Retighten if necessary. •Replace gasket if necessary.			<input type="radio"/>	<input type="radio"/>
Spark arrester	•Clean			<input type="radio"/>	<input type="radio"/>
*Wheels	•Check balance/damage/runout. •Replace if necessary.		<input type="radio"/>	<input type="radio"/>	<input type="radio"/>
*Wheel bearings	•Check bearing assembly for looseness/damage. •Replace if damaged.		<input type="radio"/>	<input type="radio"/>	<input type="radio"/>
*Steering system	•Check operation. •Replace if damaged. •Check toe-in. •Adjust if necessary.		<input type="radio"/>	<input type="radio"/>	<input type="radio"/>
*Drive shaft boots	•Check operation. •Replace if damaged.			<input type="radio"/>	<input type="radio"/>
*Suspension	•Check operation. •Correct if necessary.			<input type="radio"/>	<input type="radio"/>

ITEM	WHICHEVER COMES FIRST ROUTINE	INITIAL		EVERY	
		mi	100	600	1200
		Km	150	1000	2000
		MONTH	1	6	12
*Knuckle shafts/ Steering shaft	•Lubricate every 6 months.			<input type="radio"/>	<input type="radio"/>
*Fittings and Fasteners	•Check all chassis fittings and fasteners. •Correct if necessary.		<input type="radio"/>	<input type="radio"/>	<input type="radio"/>

* : It is recommended that these items be serviced by a KYMCO dealer.

** : Lithium soap base grease.

3. INSPECTION/ADJUSTMENT

FUEL LINE

Check the fuel tubes and replace any parts, which show signs of deterioration, damage or leakage.

* Do not smoke or allow flames or sparks in your working area.

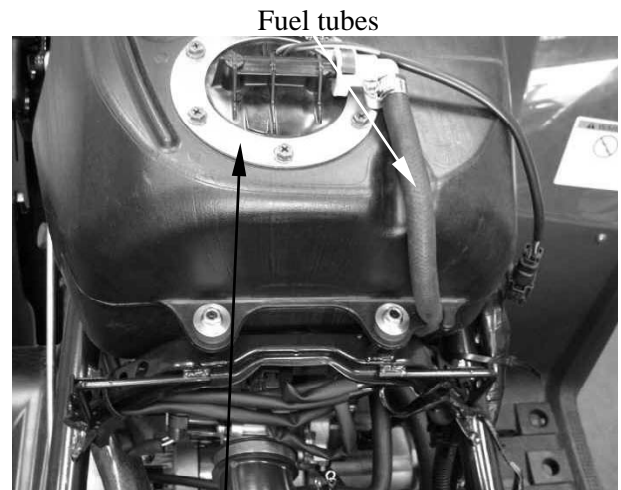

Fuel pump

THROTTLE OPERATION

Check the throttle to swing for smooth movement.

Measure the throttle to swing free play.

Free Play (A): 3~5 mm

To adjust throttle free play:

1. Slide the rubber sleeve (1) back to expose the throttle cable adjuster (2).
2. Loosen the lock nut (3), then turn the adjuster to obtain the correct free play. (3~5 mm)
3. Tighten the lock nut and reinstall the sleeve.

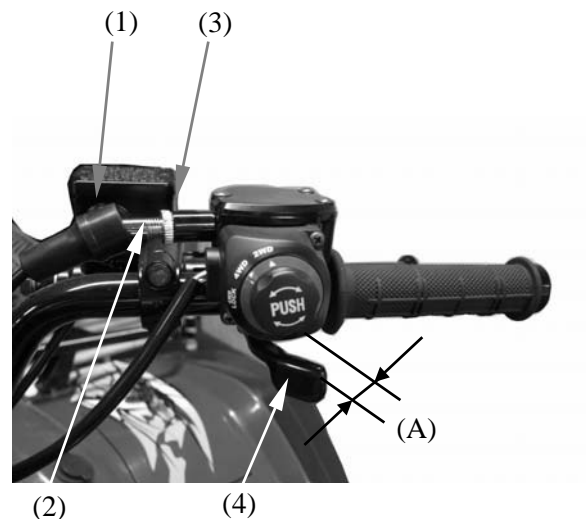

Other checks:

Check the throttle cable for kinks and signs of wear that could cause stretching or failure. Lubricate the throttle cable with a commercially available lubricant to prevent premature wear and corrosion.

3. INSPECTION/ADJUSTMENT

SPEED LIMITER

The speed limiter keeps the throttle from fully opening, even when the throttle lever is pushed to the maximum. Screwing in the adjuster limits the maximum engine power available and decreases the maximum speed of the ATV.

Speed limiter length (A): 13 mm

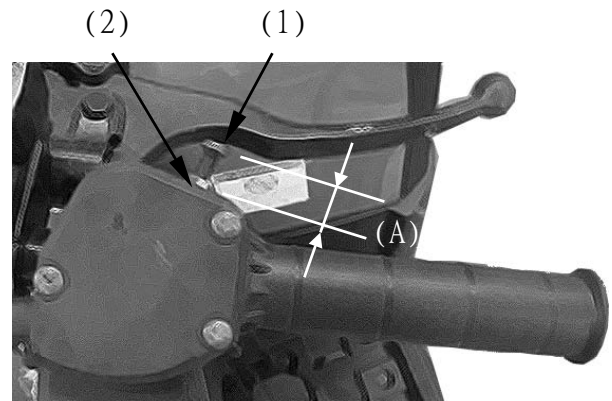

⚠ WARNING
<p>POTENTIAL HAZARD Improper adjustment of the speed limiter and throttle.</p>
<p>WHAT CAN HAPPEN The throttle cable could be damaged. Improper throttle operation could result. You could lose control, have an accident or be injured.</p>
<p>HOW TO AVOID THE HAZARD Do not turn the speed adjuster out more than 13 mm (0.52 in). Always make sure the throttle lever free play is adjusted to 1.0~4.0 mm (0.04~0.16 in).</p>

Adjustment

1. Loosen the lock nut (1).
2. Turn the adjuster (2) in or out until the specified speed limiter length is obtained.
Turning in: Speed limiter length is decreased.
Turning out: Speed limiter length is increased.
3. Tighten the lock nut.

AIR CLEANER

AIR CLEANER REPLACEMENT

1. Remove the seat (refer to the “**FRAME COVERS**” section in the chapter 2).
3. Unlatch the six retainer clips (1) and remove the air cleaner housing cover (2).

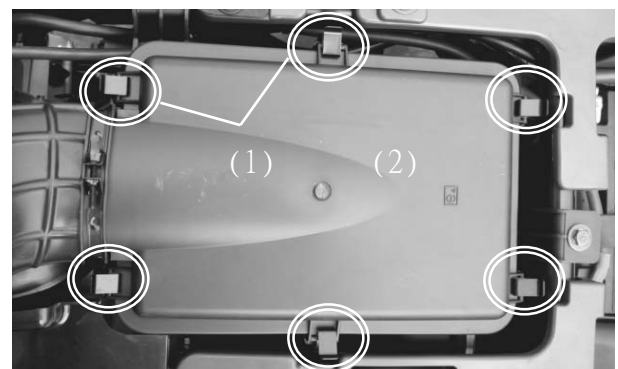

3. INSPECTION/ADJUSTMENT

3. Loosen the screw (3) and remove the air cleaner assembly (4) from the air cleaner housing.
4. Unscrew the clamp (5)

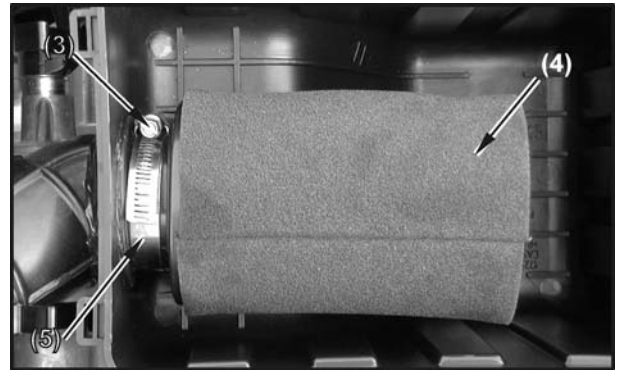

5. Remove the outer air cleaner (7).
6. Remove the screw/washers (6) and remove the air cleaner assembly from the air cleaner holder (8).
7. Remove the inner air cleaner (9) and air cleaner screen (10) from the air cleaner guide (11).
8. Remove the air cleaner screen from the inner air cleaner.

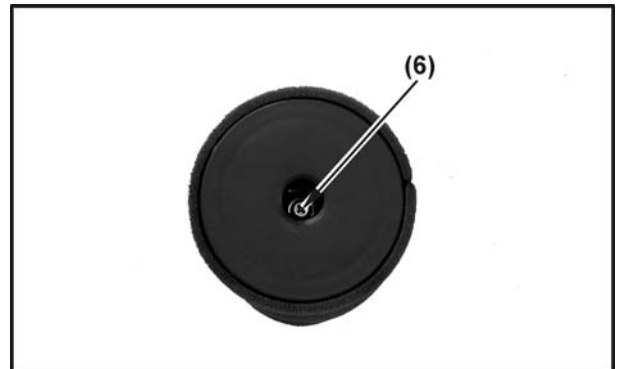

CLEAN AIR FILTER ELEMENT

Wash the element gently, but thoroughly in solvent.

* Use parts cleaning solvent only. Never use gasoline or low flash point solvents which may lead to a fire or explosion.

Squeeze the excess solvent out of the element and let dry.

* Do not twist or wring out the foam element. This could damage the foam material.

Apply the engine oil.
Squeeze out the excess oil.

* The element should be wet but not dripping.

More frequent replacement is required when riding in unusually dusty or rainy areas.

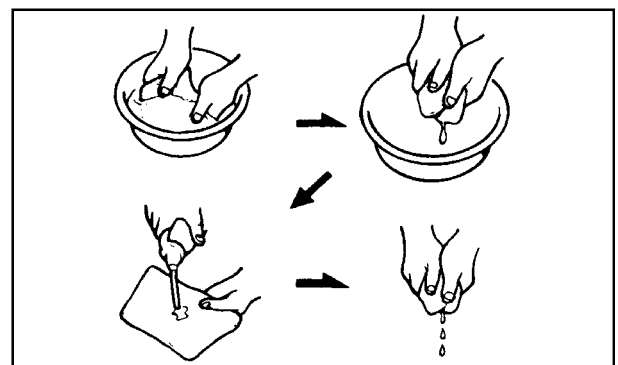
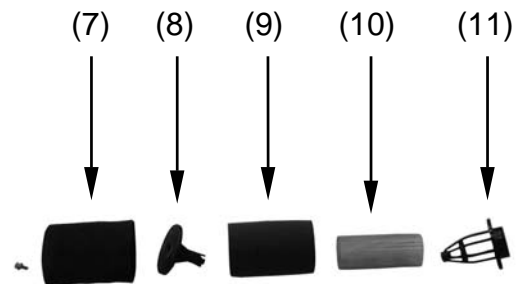

AIR CLEANER HOUSING DRAIN

1. Remove the drain tube (1) by removing the clip (3).
2. Drain the deposits.
3. Reinstall the drain tube, securing it with the clip.

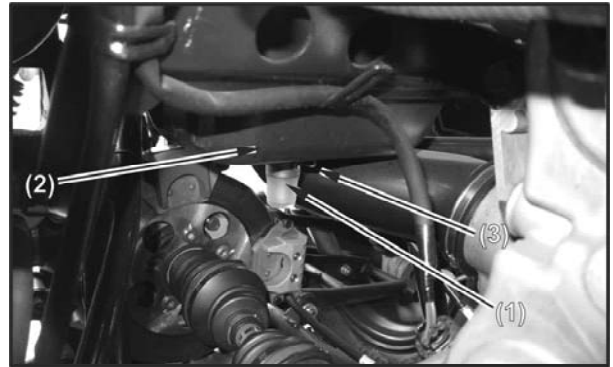

L COVER DUCT A ELEMENT

To clean the element
Remove front center cover (refer to the “**FRAME COVERS**” section in the chapter 2).

Remove the screws from air inlet hose.
Remove the element

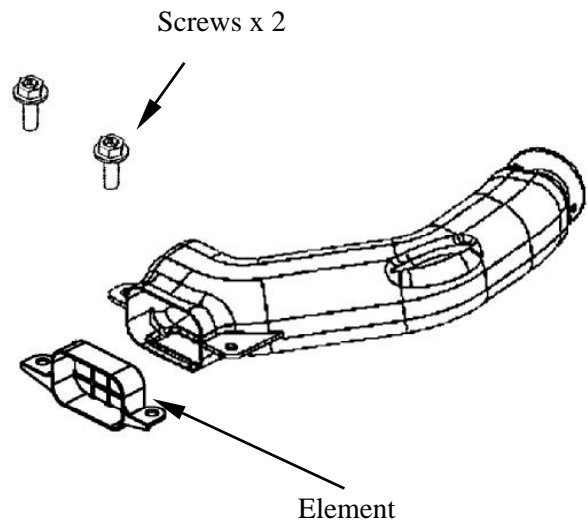

Tap the element lightly to remove most of the dust and dirt.
Blow out the remaining dirt with compressed air.

Installation is in the reverse order of removal.

If necessary replace the element.

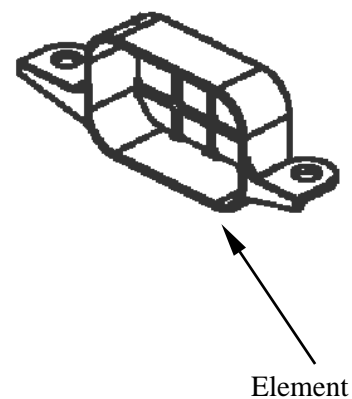

3. INSPECTION/ADJUSTMENT

SPARK PLUG

Disconnect the spark plug cap and clean around the spark plug.

* Clean around the spark plug base with compressed air before removing, and be sure that no debris is allowed to enter the combustion chamber.

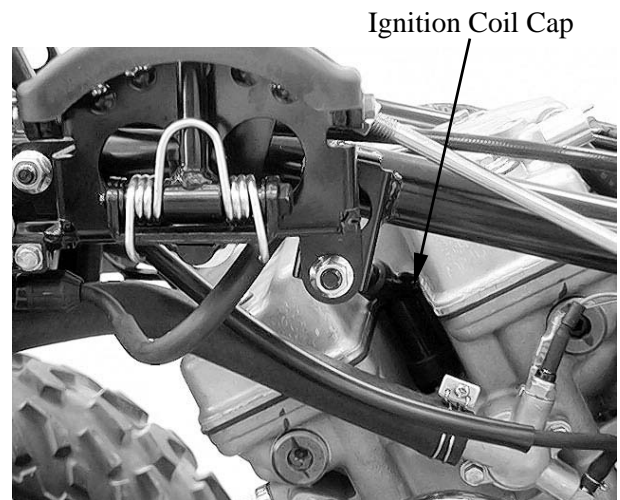

Remove the spark plug using a equipped spark plug wrench or an equivalent tool.

Inspect or replace as described in the maintenance schedule.

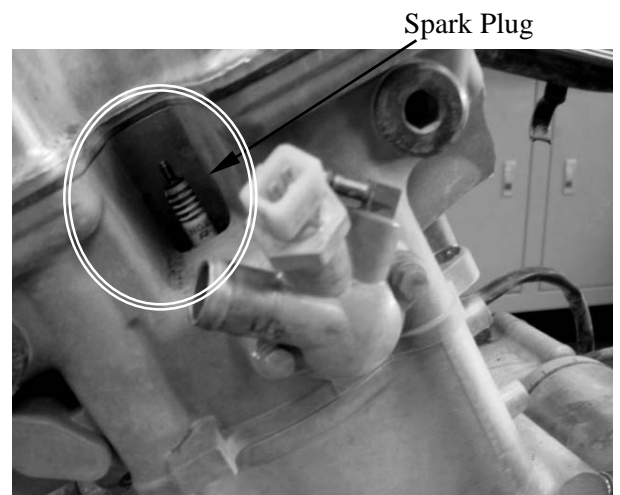

INSPECTION

Remove the carbon deposits from the spark plug with a small wire brush or a spark plug cleaning machine.

The spark plug should be replaced periodically. Whenever removing the carbon deposits, be sure to observe the operational color of the spark plug's porcelain tip. This color tells you whether or not the standard spark plug is suitable for your type of usage. A normal operating spark plug should be light brown or tan color. If the spark plug is very white or glazed appearing, then it has been operating much too hot. This spark plug should be replaced with the colder plug.

Recommended spark plug: NGK: CR7E

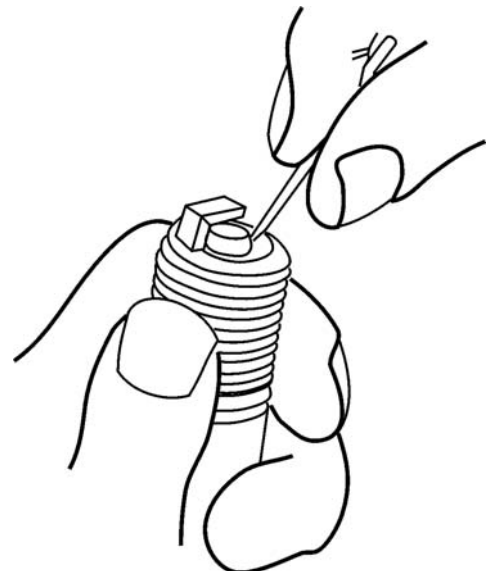

3. INSPECTION/ADJUSTMENT

Measure the spark plug gap between the center and side electrodes with the feeler gauge.

If necessary, adjust the gap by bending the side electrode carefully.

Spark plug gap:

0.6–0.7 mm (0.024–0.028 in)

Install the spark plug in the cylinder head and hand tighten, then torque to the specification.

Torque: 1.2 kgf-m (12 N-m) Install the spark plug cap.

Install the removed parts in the reverse order of removal.

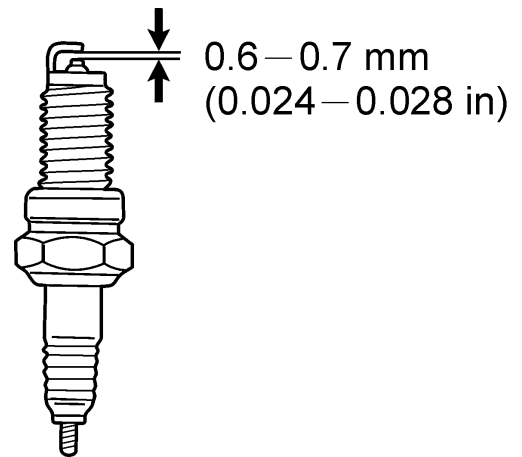

3. INSPECTION/ADJUSTMENT

VALVE CLEARANCE

* Inspect and adjust the valve clearance while the engine is cold (Below 35°C/95°F).

To adjust:

Remove the right floorboard (refer to the “**FRAME COVERS**” section in the chapter 2).

Remove the cylinder head cover (refer to the “**CYLINDER HEAD COVER REMOVAL/INSTALLATION**” section in the chapter 8).

Remove the timing hole cap and O-ring.

Timing Hole Cap/O-ring



Remove the recoil starter and O-rings (refer to the “**STARTER PULLEY REMOVAL/INSPECTION/INSTALLATION**” section in the chapter 8).

Turn the crankshaft clockwise and align the “T” mark on the flywheel with the index mark on the right crankcase cover.

Index Mark

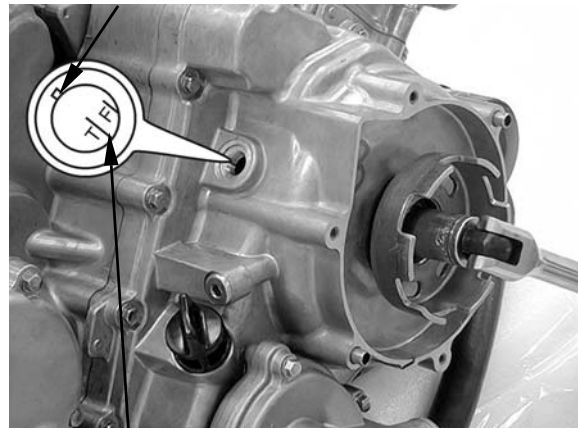

“T” Mark

The punch marks on the camshaft should face upward as shown.

If the punch marks on the camshaft are facing downward, turn the crankshaft clockwise one full turn (360°) and the punch marks are facing upward.

Punch Marks



3. INSPECTION/ADJUSTMENT

Adjust by loosening the valve adjusting screw lock-nut and turning the adjusting screw until there is a slight drag on the thickness gauge.

Valve clearance (when cold):

IN.: 0.1 mm

EX.: 0.1 mm

Apply oil to the valve adjusting screw lock-nut threads and seating surface.

Hold the adjusting screw and tighten the lock nut.

Wrench Thickness Gauge Valve Adjusting

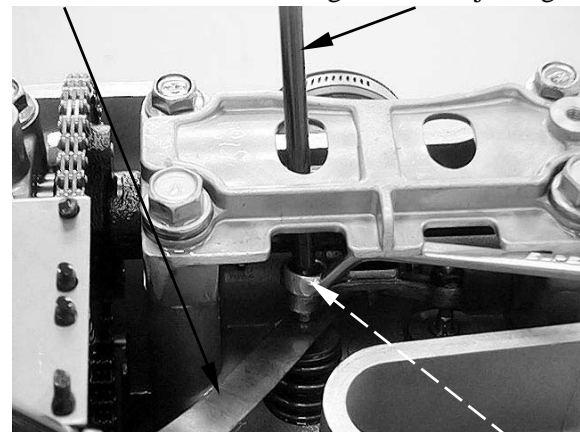

Lock Nut

Special tool:

Valve adjusting wrench **A120E00080**

Torque: 0.9 kgf-m (9 N-m)

After tightening the lock nut, recheck the valve clearance.

Install the removed parts in the reverse order of removal.

IDLE SPEED INSPECTION

* The engine must be warm(80°C over) for accurate idle speed inspection

Warm up the engine before this operation. Start the engine and connect a tachometer or kymco diagnostic tool. attached the specified idle speed.

Idle Speed: 1400±100 rpm



Idle Speed

3. INSPECTION/ADJUSTMENT

CYLINDER COMPRESSION

Warm up the engine before compression test.

Remove the spark plug.

Insert a compression gauge.

Open the throttle valve fully and push the starter button to test the compression.

Cylinder compression : 15 kg/cm²

If the compression is low, check for the following:

- Leaky valves
- Valve clearance too small
- Leaking cylinder head gasket
- Worn piston rings
- Worn piston/cylinder

If the compression is high, it indicates that carbon deposits have accumulated on the combustion chamber and the piston head.

Compression Gauge

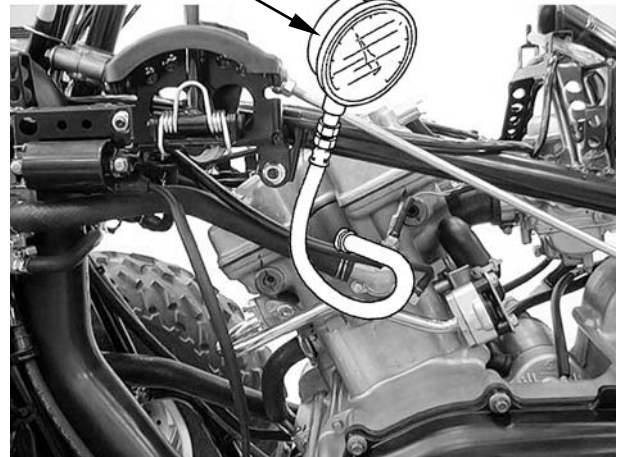

ENGINE OIL

OIL LEVEL

Place the machine on a level place.

Warm up the engine for several minutes and stop it.

* Run the engine for 2~3 minutes and check the oil level after the engine is stopped for 2~3 minutes.

Check the oil level through the inspection window.

The oil level should be between the maximum (H) and minimum (L) marks. If the level is low, add oil to raise it to the proper level.

Recommended engine oil:

KYMCO 4-stroke oil or equivalent motor oil API service classification: SJ

Viscosity: SAE 5W30

* Other viscosities shown in the chart may be used when the average temperature in your riding area is within the indicated range.

Upper Level

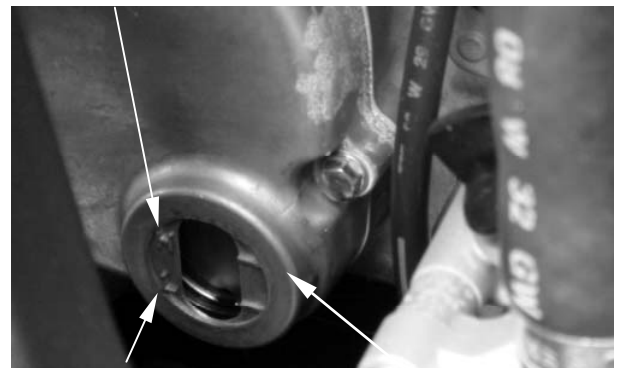

Lower Level

Inspection Window

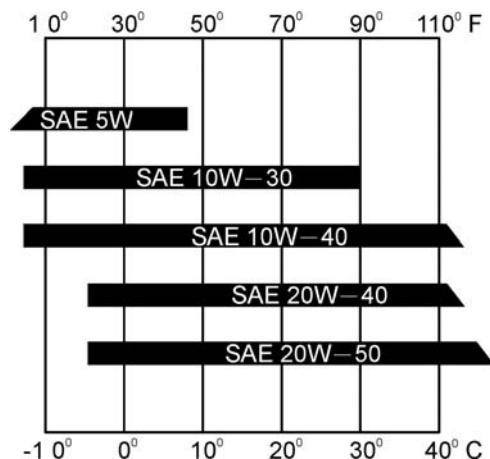

ENGINE OIL REPLACEMENT AND OIL FILTER CLEANING

1. Place the machine on a level place.
2. Warm up the engine for several minutes and stop it.
3. Place a container under the engine.
4. Remove the oil filler cap (1).

* Be sure no foreign material enters the crankcase.

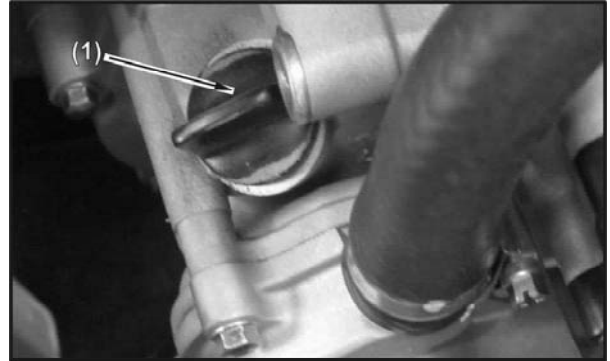

5. Remove the oil filter cap (2) to drain the oil.

* The engine oil will drain more easily while the engine is warm.

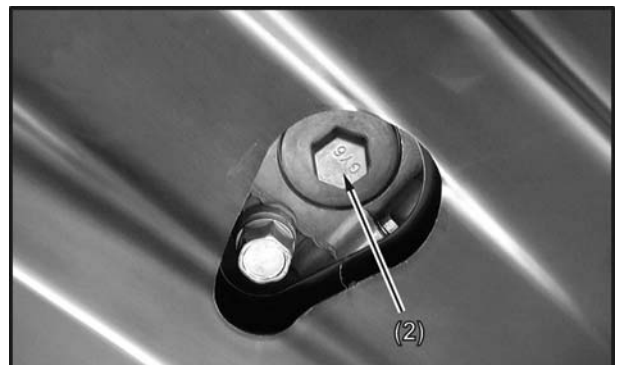

6. Clean the oil strainer with solvent. Inspect the O-ring and replace if damaged. Reinstall the O-ring, oil strainer, compression spring and oil filter cap. Tighten the oil filter cap to specification.

Torque: 1.5 kgf-m (15 N-m)

7. Fill the engine with oil and install the oil filler cap.

Engine oil capacity

At disassembly: 3.6 liter

At change: 3.0 liter

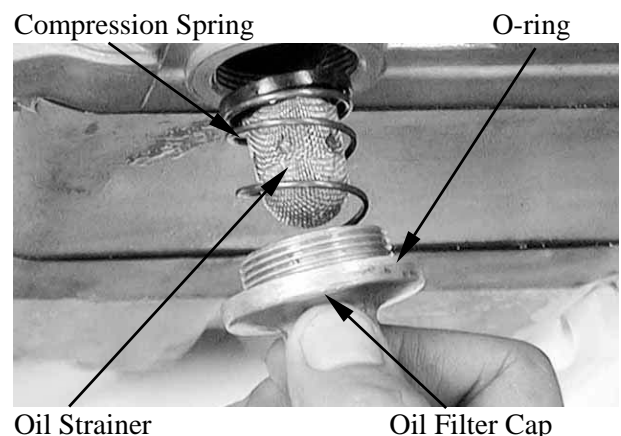

3. INSPECTION/ADJUSTMENT

ENGINE OIL REPLACEMENT (WITH OR WITHOUT OIL FILTER CARTRIDGE REPLACEMENT)

1. Place the machine on a level place.
2. Warm up the engine for several minutes and stop it.
3. Place a container under the engine.
4. Remove the oil fill cap (1).

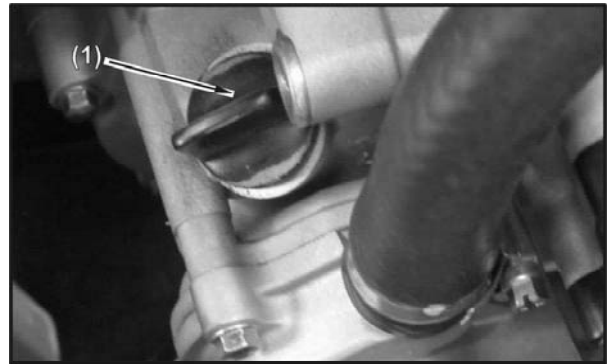

* Be sure no foreign material enters the crankcase.

5. Remove the drain plug (2) to drain the oil.

* The engine oil will drain more easily while the engine is warm.



* Skip steps 6 to 10 if the oil filter cartridge is not being replaced.

6. Remove the three fasteners (3) and then remove right side cover (4).

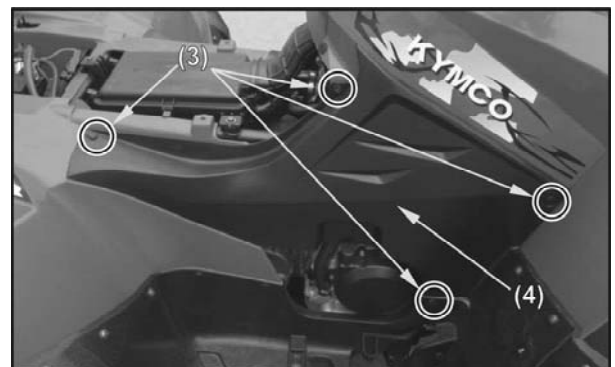

3. INSPECTION/ADJUSTMENT

7. Remove the oil filter cartridge (5) with an oil cartridge wrench.

Special tool:

Oil cartridge wrench A120E00052

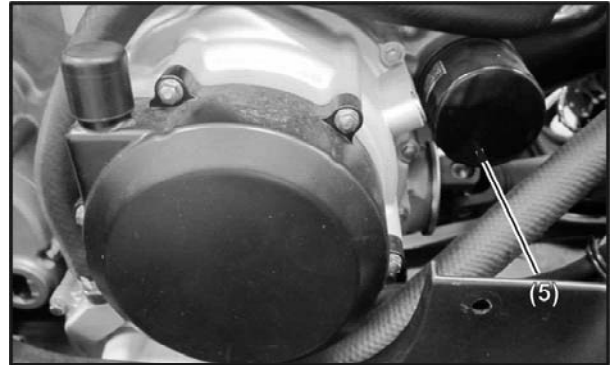

8. Apply a light coat of clean engine oil to the O-ring (6) of the new oil filter cartridge.

* Make sure the O-ring is seated properly.

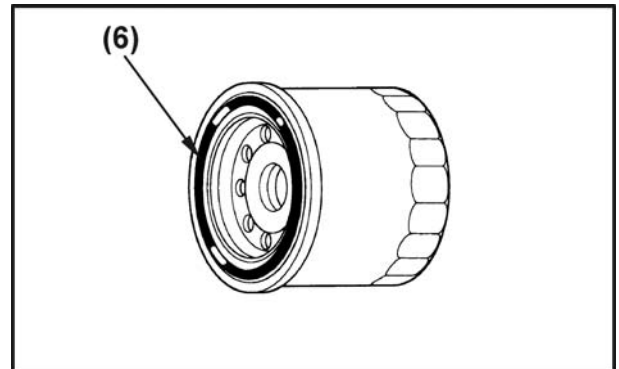

9. Install the new oil filter cartridge with an oil cartridge wrench, and then tighten it to the specified torque.

Torque: 1 kgf-m (10 N-m)

10. Install right side cover.
11. Reinstall the drain plug and tighten the drain plug to the specified torque.

Torque: 2.5 kgf-m (25 N-m)

12. Add the specified amount of recommended engine oil, and then install the engine oil filler cap and tighten it.

Engine oil capacity

At disassembly: 3.6 liter

At change: 3.0 liter

* Be sure no foreign material enters the crankcase.

3. INSPECTION/ADJUSTMENT

13. Start the engine and warm it up for several minutes. While warming up, check for oil leakage. If oil leakage is found, turn the engine off immediately and check for the cause.
14. Turn the engine off, and then check the oil level through the inspection window (7) and correct it if necessary.

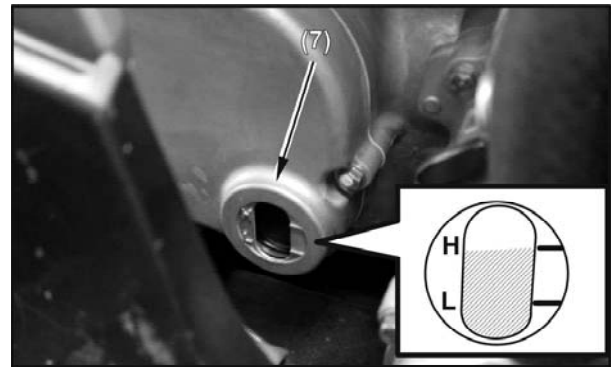

REAR GEAR BOX OIL

Change the oil in the rear gear case when specified by the Maintenance Schedule. Change the oil with the rear gear case warm, and the ATV on level ground to assure complete and rapid draining.

Rear drive gear oil replacement

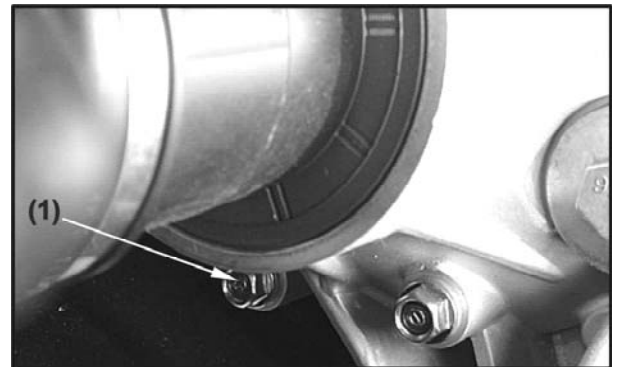

2. To drain the oil, first place an oil drain pan under the oil drain plug (1).
3. Remove the oil filler cap (2), then remove the drain plug.
4. After the oil has completely drained, reinstall the drain plug.

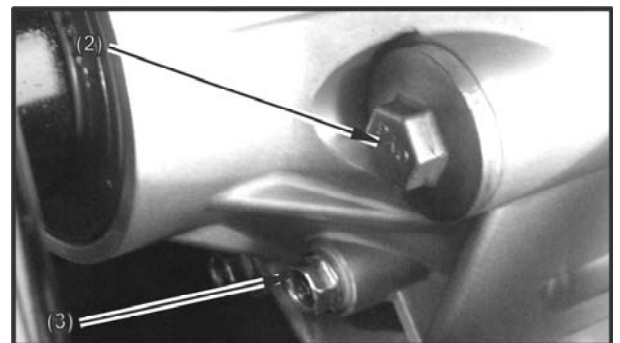

Torque: 2 kgf-m (20 N-m)

5. Fill the gear case with the recommended oil.

Recommended oil: SAE 80

Oil quantity:

Periodic oil change: 0.23 L

3. INSPECTION/ADJUSTMENT

6. Install the oil filler cap and oil level check bolt(3).

Torque:

Oil filler cap: 1.5 kgf-m (15 N-m)

Oil level check bolt: 2 kgf-m (20 N-m)

* Be sure no foreign material enters the crankcase.

7. Install the skid plate.

FRONT GEAR BOX OIL

Change the oil in the front gear case when specified by the Maintenance Schedule. Change the oil with the front drive gear case warm, and the ATV on level ground to assure complete and rapid draining.

Front gear box oil replacement

1. To drain the oil, first place an oil drain pan under the oil drain bolt(1).
2. Remove the oil filler cap (2).
3. After the oil has completely drained, reinstall and tighten the drain bolt .
4. Fill the gear case with the recommended oil.

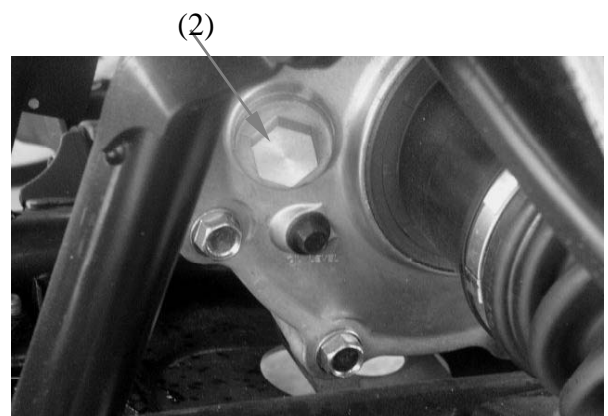
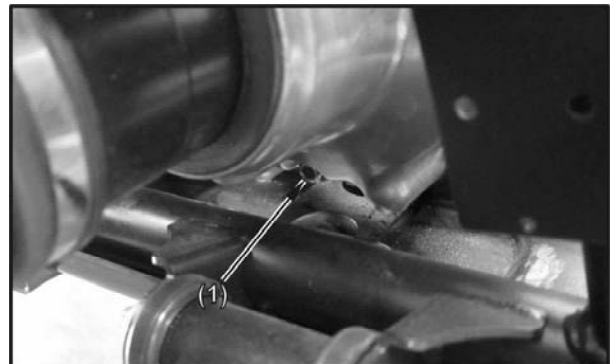

Recommended oil: SAE 80

Oil quantity:

Periodic oil change: 0.25L

3. INSPECTION/ADJUSTMENT

5. Remove the oil level check bolt (3). Make sure the oil level reaches the oil level check hole.
6. Install and tighten the oil filler cap and oil level check bolt to the specified torque.

Torque:

Oil filler cap: 1.5 kgf-m (15 N-m,)

Oil level check bolt: 1.0 kgf-m (10 N-m,)

* Be sure no foreign material enters the crankcase.

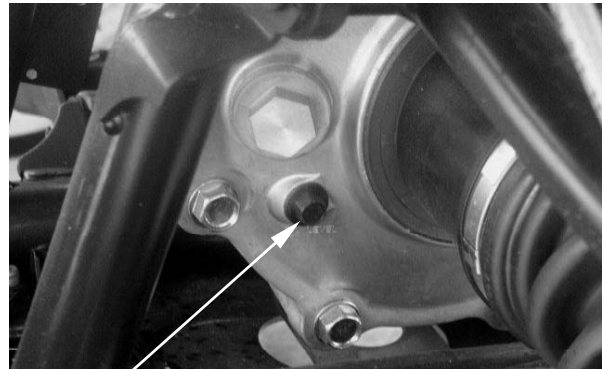

(3)

SPARK ARRESTER

Be sure the exhaust pipe and muffler are cool before cleaning the spark arrester.

1. Remove the three bolts (1).

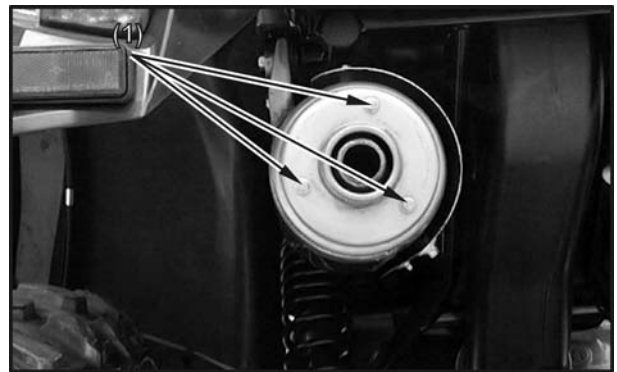

2. Remove the spark arrester (2) and the gasket (3) from the muffler.

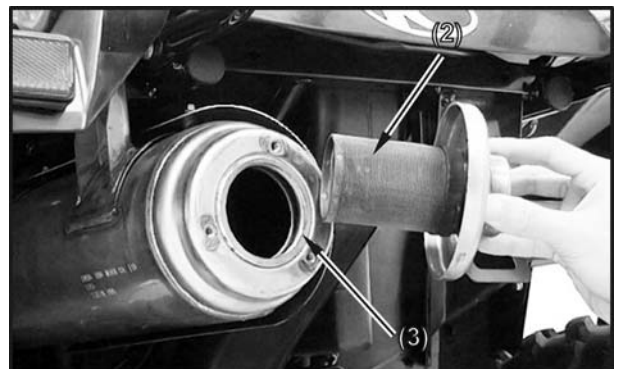

3. INSPECTION/ADJUSTMENT

3. Use a brush to remove carbon deposits from the spark arrester screen. Be careful to avoid damaging the spark arrester screen. The spark arrester must be free of breaks and holes. Replace, if necessary. Check the gasket. Replace, if necessary.
4. Install the spark arrester and the gasket in the muffler and tighten the three bolts securely.

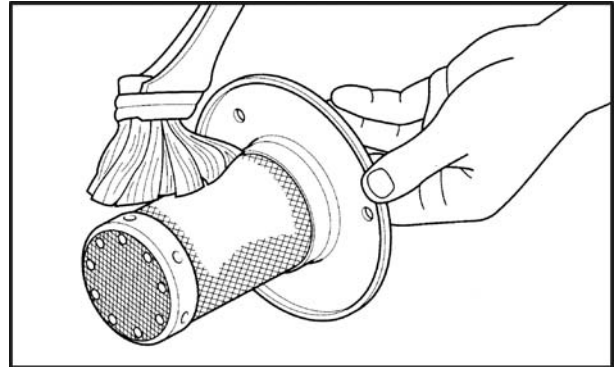

⚠ WARNING

POTENTIAL HAZARD

**Improper cleaning of the spark arrester.
Hot exhaust system.**

WHAT CAN HAPPEN

- Could injure the eyes.**
- Could cause burns.**
- Could cause carbon monoxide poisoning, possibly leading to death.**
- Could start a fire**

HOW TO AVOID THE HAZARD

- When cleaning the spark arrester:**
- Always let the exhaust system cool prior to touching exhaust components**
- Do not start the engine when cleaning the exhaust system.**

DRIVE SHAFT BOOTS

- Check the protective boots for holes or tears.
- If any damage is found, have them replaced.

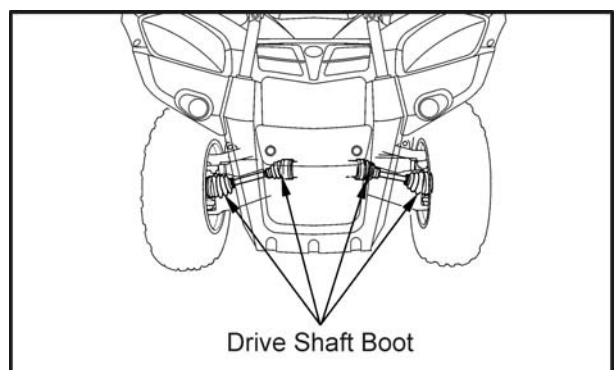

3. INSPECTION/ADJUSTMENT

DRIVE BELT

Remove the left crankcase cover (refer to the “**LEFT CRANKCASE COVER REMOVAL/INSTALLATION**” section in the chapter 10).

Inspect the drive belt for cracks, scaling, chipping or excessive wear.
Measure the V-belt width

Service limit (A): 30.8 mm

Replace the drive belt if out of specification.

Refer to the “**DRIVE PULLEY, DRIVE V-BELT AND DRIVEN PULLEY REMOVAL/INSPECTION/INSTALLATION**” section in the chapter 10 for removal/installation.

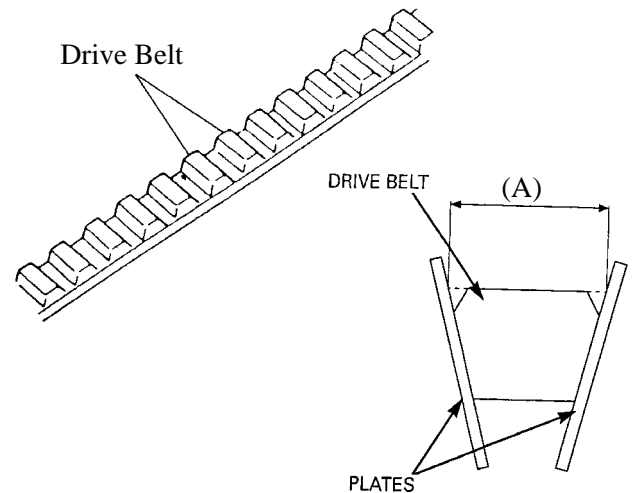

BRAKE PADS INSPECTION

A wear indicator is provided on each brake. The indicators are allowed checking of brake pads wear. Check the position of the indicator. If the indicator reaches the wear limit line, to replace the pads.

3. INSPECTION/ADJUSTMENT

BRAKE FLUID INSPECTION

Check if the fluid level is below the lower level mark through the inspection window.

Inspection Window (R/L Brake Lever)

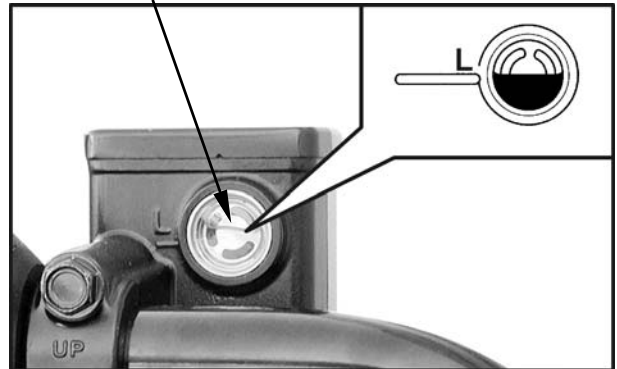

Inspection Window (Rear Brake Pedal)

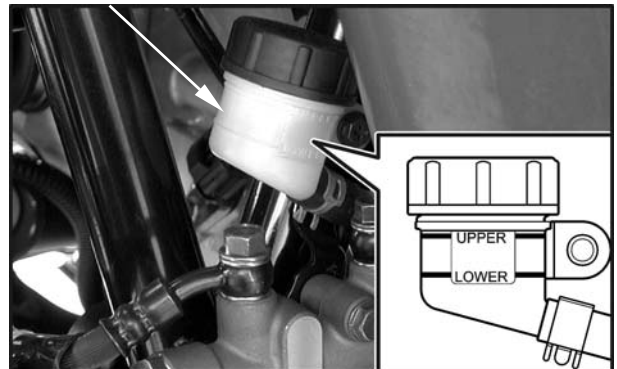

HEADLIGHT AIM

Turn the ignition switch ON and start the engine.
Turn on the headlight switch.
Adjust the headlight aim by turning the headlight aim adjusting button(1)

Adjust Button

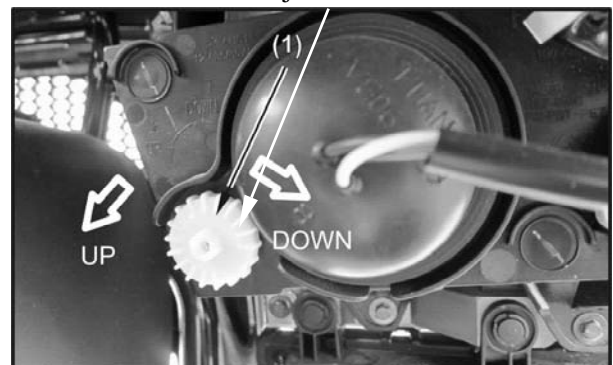

3. INSPECTION/ADJUSTMENT

STEERING SYSTEM INSPECTION

Place the machine on a level place.

Check the steering column bushings and bearings:

Move the handlebar up and down, and/or back and forth.

Replace the steering column bushings and or bearings if excessive play.

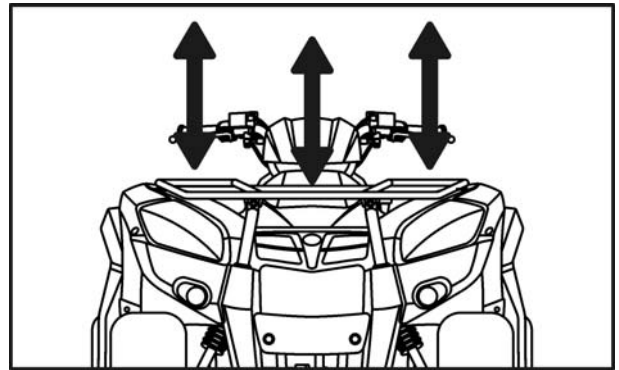

Check the tie-rod ends

Turn the handlebar to the left and/or right until it stops completely, then slightly moving the handlebar from left to right.

Replace the tie-rod ends if tie-rod end has any vertical play.

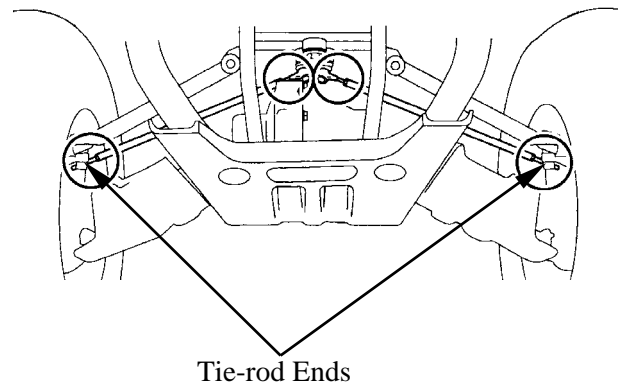

Raise the front end of the machine so that there is no weight on the front wheels.

Check ball joints and/or wheel bearings.

Move the wheels laterally back and forth.

Replace the front arms and/or wheel bearings if excessive free play.

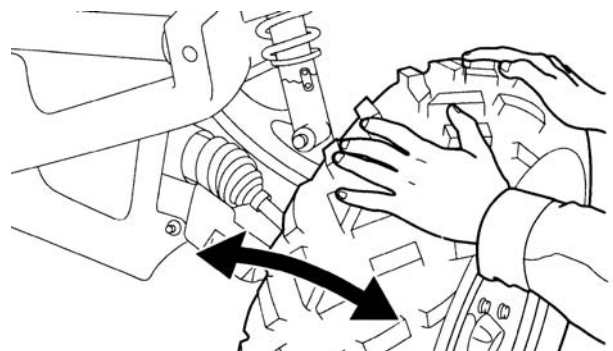

TOE-IN ADJUSTMENT

Place the machine on a level place.

Measure the toe-in

Adjust if out of specification.

Toe-in measurement steps:

Mark both front tire tread centers.

Raise the front end of the machine so that there is no weight on the front tires.

Fix the handlebar straight ahead.

Measure the width A between the marks.

Rotate the front tires 180 degrees until the marks come exactly opposite.

Measure the width B between the marks.

Calculate the toe-in using the formula given below.

Toe-in = B - A

Toe-in: 0~15 mm

If the toe-in is incorrect, adjust the toe-in.

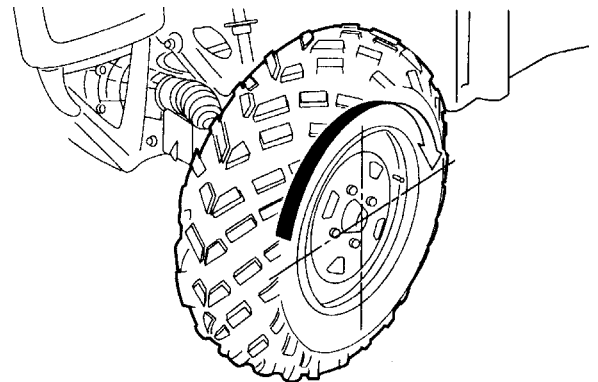
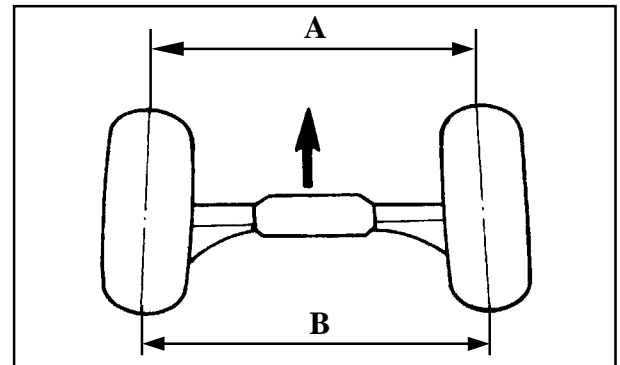

Adjust the toe-in step:

Mark both tie-rods ends.

This reference point will be needed during adjustment.

Loosen the lock nuts (tie-rod end) of both tie-rods

The same number of turns should be given to both tie-rods right and left until the specified toe-in is obtained, so that the lengths of the rods will be kept the same.

Tighten the rod end lock nuts of both tie-rods.

Tie-rod lock Nuts

Torque: 2.5 kgf-m (25 N-m)

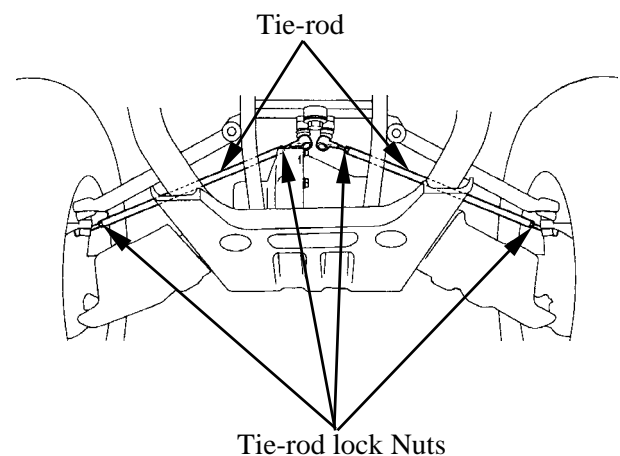

- *
- Be sure that both tie-rod are turned the same amount. If not, the machine will drift tight or left even though the handlebar is positioned straight which may lead to mishandling and accident.
 - After setting the toe-in to specification, run the machine slowly for some distance with hands placed lightly on the handlebar and check that the handlebar responds correctly. If not, turn either the right or left tie-rod within the toe-in specification.

3. INSPECTION/ADJUSTMENT

* The threads on both rod-end must be of same length.

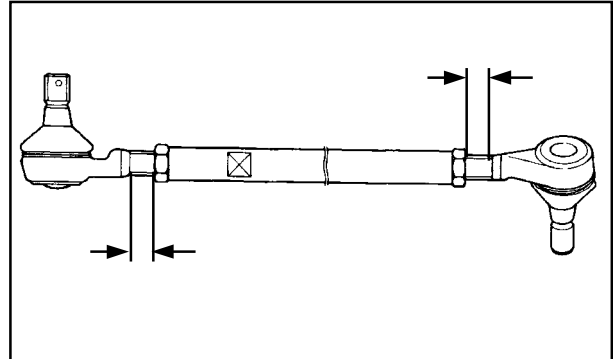

WHEELS/TIRES

Check the tires for cuts, imbedded nails or other damages.
Check the tire pressure.

* Tire pressure should be checked when tires are cold.

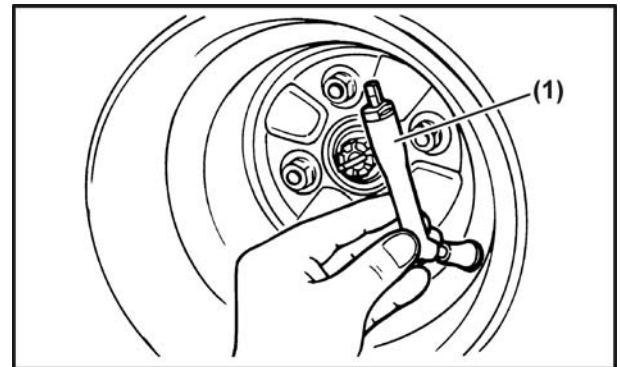

TIRE PRESSURE

	1 Rider
Front (off road)	0.35 kgf/cm ² (35 Kpa, 5.0psi)
Rear (off road)	0.32 kgf/cm ² (32 Kpa, 4.5psi)
Front (on road)	0.38 kgf/cm ² (38 Kpa, 5.5psi)
Rear (on road)	0.35 kgf/cm ² (35 Kpa, 5.0psi)

Front Axle Nut



TIRE SIZE

Front : 25X8-12
Rear : 25X10-12—**OFF ROAD**
 Front : 26X8-14
 Rear : 26X10-14—**ON ROAD**

Check the front axle nut for looseness.

3. INSPECTION/ADJUSTMENT

Check the rear axle nut for looseness.
If the axle nuts are loose, tighten them to the specified torque.

Torque:

Front: 6.1 kgf-m (61 N-m)

Rear: 6.1 kgf-m (61N-m)



Rear Axle Nut

Inspect the tire surfaces.
Replace if wear or damage.

Tire wear limit: 4 mm (0.16 in)

* It is dangerous to ride with a worn out tire. When a tire wear is out of specification, replace the tire immediately.

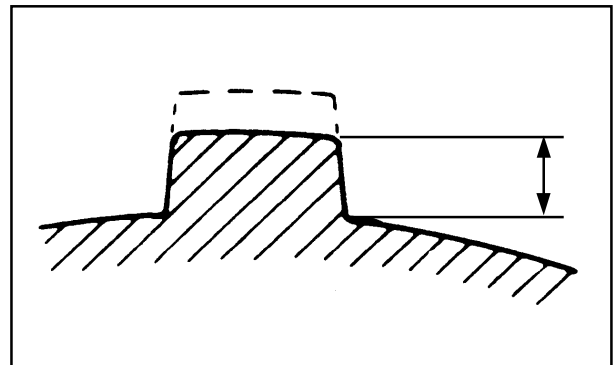

WHEEL INSPECTION

Inspect the wheel.
Replace if damage or bends
Always balance the wheel when a tire or wheel has been changed or replaced.

*

- Never attempt even small repairs to the wheel.
- Ride conservatively after installing a tire to allow it to seat itself properly on the rim.

3. INSPECTION/ADJUSTMENT

FRONT SHOCK ABSORBER

* Always adjust both front shock absorber spring pre-load to the same setting. Uneven adjustment can cause poor handling and loss of stability.

Adjustment

Turn the adjuster to increase or decrease the spring pre-load.

Standard position: 2

Minimum (Soft) position: 1

Maximum (Hard) position: 5

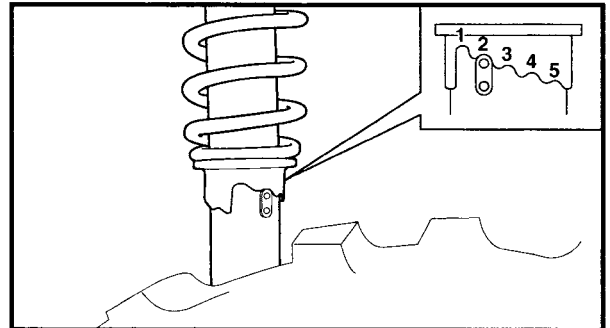

REAR SHOCK ABSORBER

* Always adjust both rear shock absorber spring pre-load to the same setting. Uneven adjustment can cause poor handling and loss of stability.

Adjustment

Turn the adjuster to increase or decrease the spring pre-load.

Standard position: 2

Minimum (Soft) position: 1

Maximum (Hard) position: 5

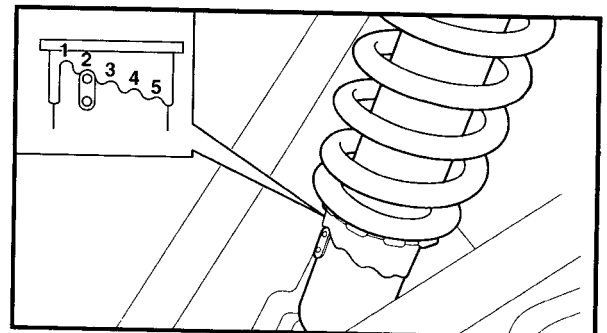

DRIVE SELECT LEVER ADJUSTMENT

1. Turn the ignition switch is OFF and make sure the engine stop.
2. Remove 3 fasteners (1), then remove the left side cover (2).

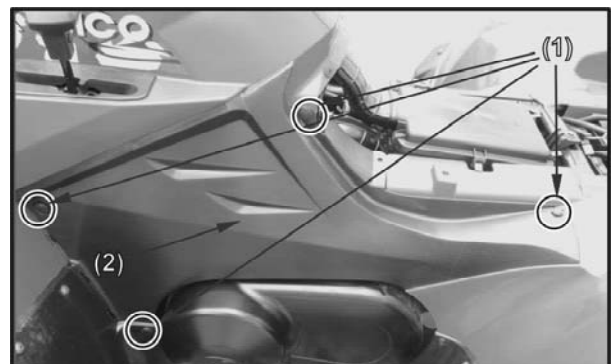

3. INSPECTION/ADJUSTMENT

4. Loosen the lock nuts (3) of rod (4).
5. Remove the bolt and nut from the rod end (shift arm side).

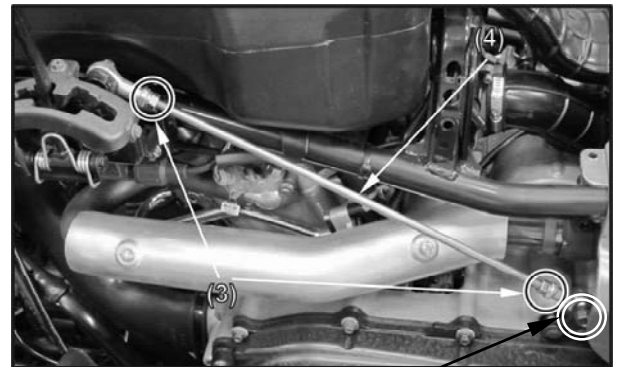

Bolt/Nut

5. Shift the drive select lever to neutral along the shift guide.

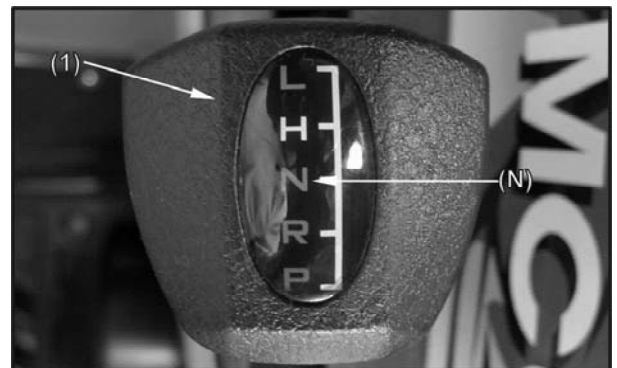

6. Shift the gear to neutral by moving the shift arm (The neutral indicator lamp comes on.)

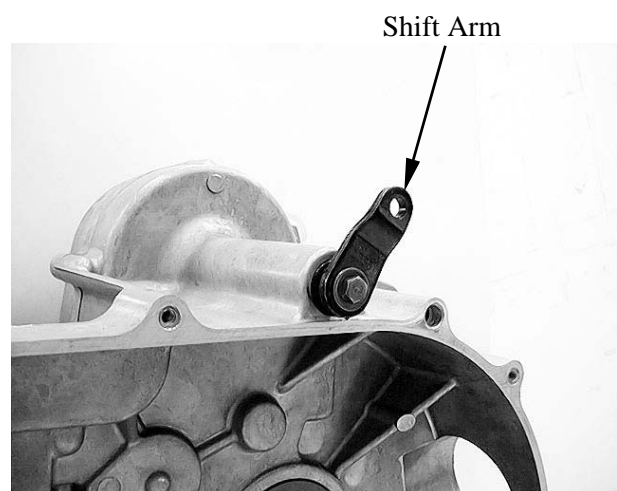

3. INSPECTION/ADJUSTMENT

7. Turn the rod clockwise or counterclockwise to align the joint ball in the rod with the hole on the shift arm, then install and tighten the bolt and nut.

* When align the joint ball in the rod with the hole on the shift arm. Always keep the joint ball original position, do not turn the joint ball.

8. Tighten the lock nuts of the rod.



CABLE INSPECTION AND LUBRICATION

* Damaged cable sheath may cause corrosion and interfere with the cable movement. An unsafe condition may result so replace such cable as soon as possible.

Inspect the cable sheath.

Replace if damage.

Check the cable operation.

Lubricate or replace if non-smooth operation.

* Hold cable-end high and apply several drops of lubricant to cable.

LEVER LUBRICATION

Lubricate the pivoting parts of each lever.

ADJUSTING THE REAR BRAKE LIGHT SWITCH (BRAKE PEDAL)

1. Loosen the lock nut.
2. Turn the adjusting nut clockwise or counterclockwise until the rear brake light comes on at the proper time.
3. Tighten the lock nut securely.

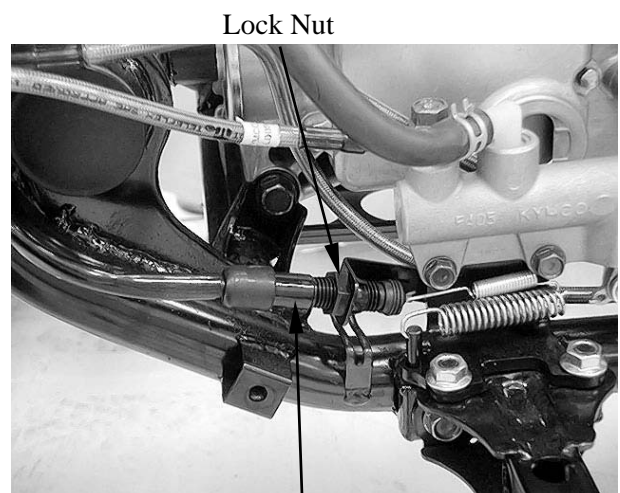

Lock Nut

Adjuster

COOLING SYSTEM

COOLANT LEVEL INSPECTION

Place the machine on the level ground.

Remove the front center cover (refer to the “**FRAME COVERS**” section in the chapter 2).

Check the coolant level in the coolant reservoir when the engine is cold as the coolant level will vary with engine temperature. The level should be between the “**FULL**” (2) and “**LOW**” (3) level surface.

If the level is low, remove the reserve tank cap (1) and fill the tank to the “**FULL**” level line with 1:1 mixture of distilled water and antifreeze (coolant mixture preparation: refer to the chapter 6 “**COOLING SYSTEM**”)

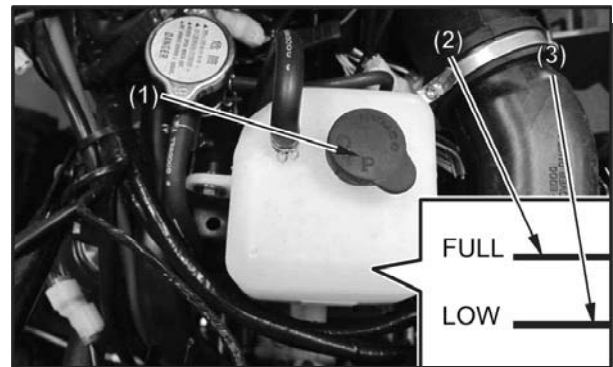

* Using coolant with silicate inhibitors may cause premature wear of water pump seals or blockage of radiator passages. Using tap water may cause engine damage.

Check to see if there are any coolant leaks when the coolant level decrease very rapidly.

If reserve tank becomes completely empty, there is a possibility of air getting into the cooling system.

Be sure to remove all air from the cooling system (refer to the “**COOLANT REPLACEMENT**” section in the chapter 6).

Reinstall the filler cap.

3. INSPECTION/ADJUSTMENT

Check for any coolant leakage from the water pump, radiator hoses and hose joints.

Check the radiator hoses for cracks or deterioration and replace if necessary.

Check that all hose clamps are tight.

Check the radiator air passages for clogs or damage.

Straighten any bent fins, and remove insects, mud or other obstructions with compressed air or low water pressure.

Replace the radiator if the air-flow is restricted over more than 20% of the radiating surface.

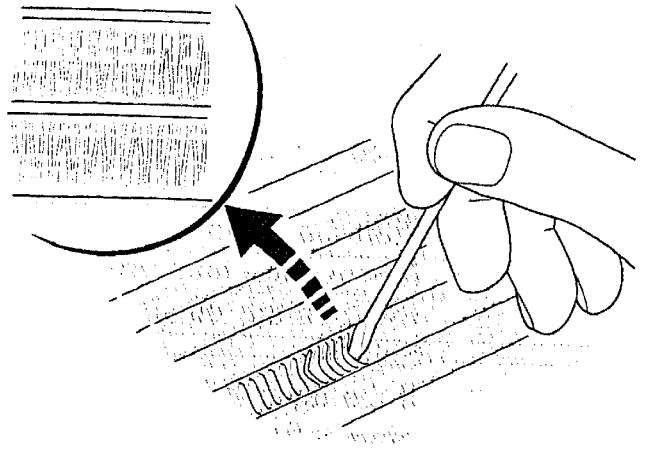

REAR PARKING BRAKE ADJUSTMENT (ON ROAD only)

Parking brake adjustment may be required if the parking brake does not work properly. Every time the brake pads are replaced, adjust the parking brake.

To adjust:

1. Release the parking brake lever.
2. The rear brake caliper is adjusted automatically when has more clearance for the parking brake lever, replace a new pad set also.
Lock the adjuster when the caliper lever applied.



Parking Brake Lever

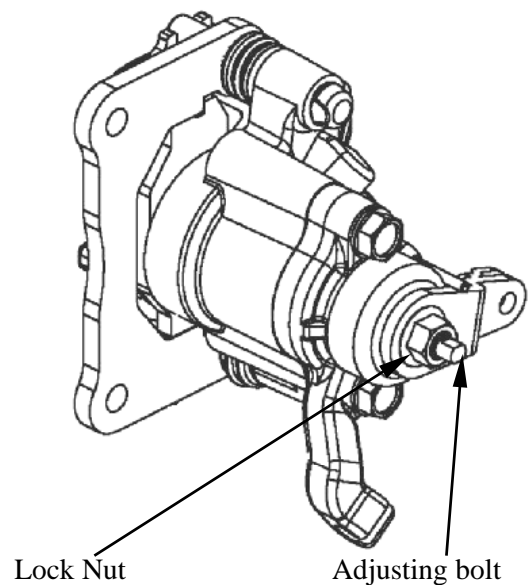

3. INSPECTION/ADJUSTMENT

3. Loosen the lock nut and adjuster on the cable.
4. Turn the adjuster in or out until the specified brake cable end length "L" is obtained.
Tighten the lock nut.



Lock Nut

Adjuster

Parking brake cable end length:

L: 53 ± 2 mm

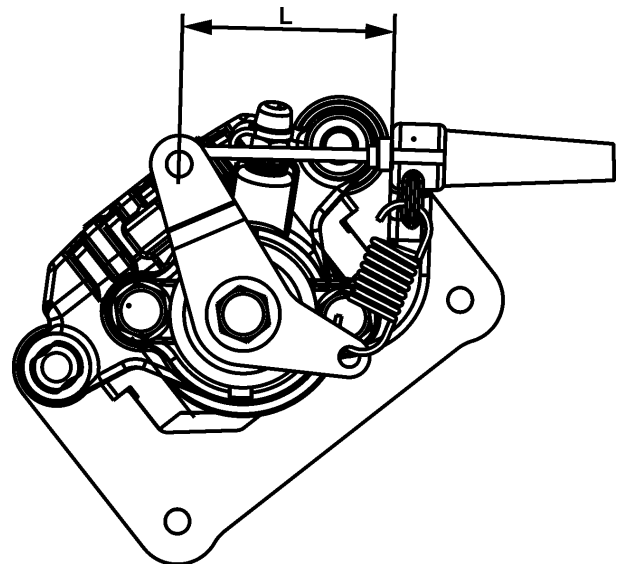

5. Slowly turn the adjusting bolt on the caliper clockwise until resistance is felt, then turn adjusting bolt 1/8 counterclockwise.
6. Tighten the lock nut to the specified torque while hold the adjusting bolt.

Torque: 1.2 kgf-m (12 N-m)

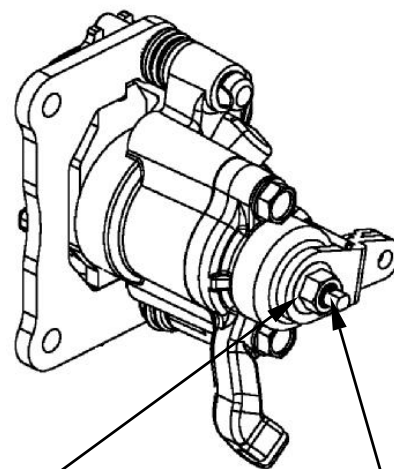

Lock Nut

Adjusting bolt

3. INSPECTION/ADJUSTMENT

7. Check the parking brake lever free play
“C”.

Free play: 0 mm

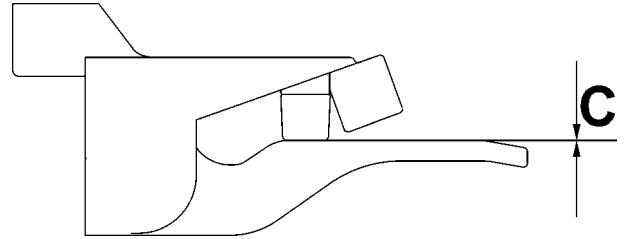

8. If the free play is incorrect, adjust the
free play by adjuster on the cable.

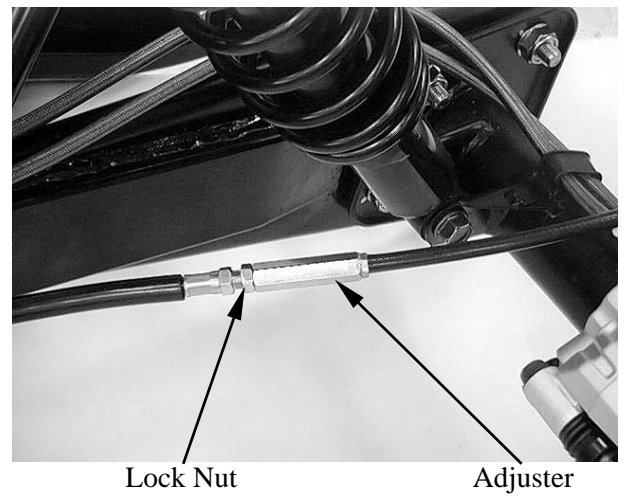

4. LUBRICATION SYSTEM

4

LUBRICATION SYSTEM

LUBRICATION SYSTEM DIAGRAM -----	4- 1
SERVICE INFORMATION-----	4- 2
TROUBLESHOOTING-----	4- 3
LUBRICATION CHECK HOLE -----	4- 4
OIL PUMP REMOVAL/INSPECTION/INSTALLATION-----	4- 5
OIL PUMP DISASSEMBLY/INSPECTION/ASSEMBLY -----	4- 9
RIGHT CRANKCASE COVER DISASSEMBLY/ASSEMBLY ----	4-12
OIL PRESSURE RELIEF VALVE-----	4-14
OIL PIPE REMOVAL/INSTALLATION-----	4-15

4. LUBRICATION SYSTEM

LUBRICATION SYSTEM DIAGRAM

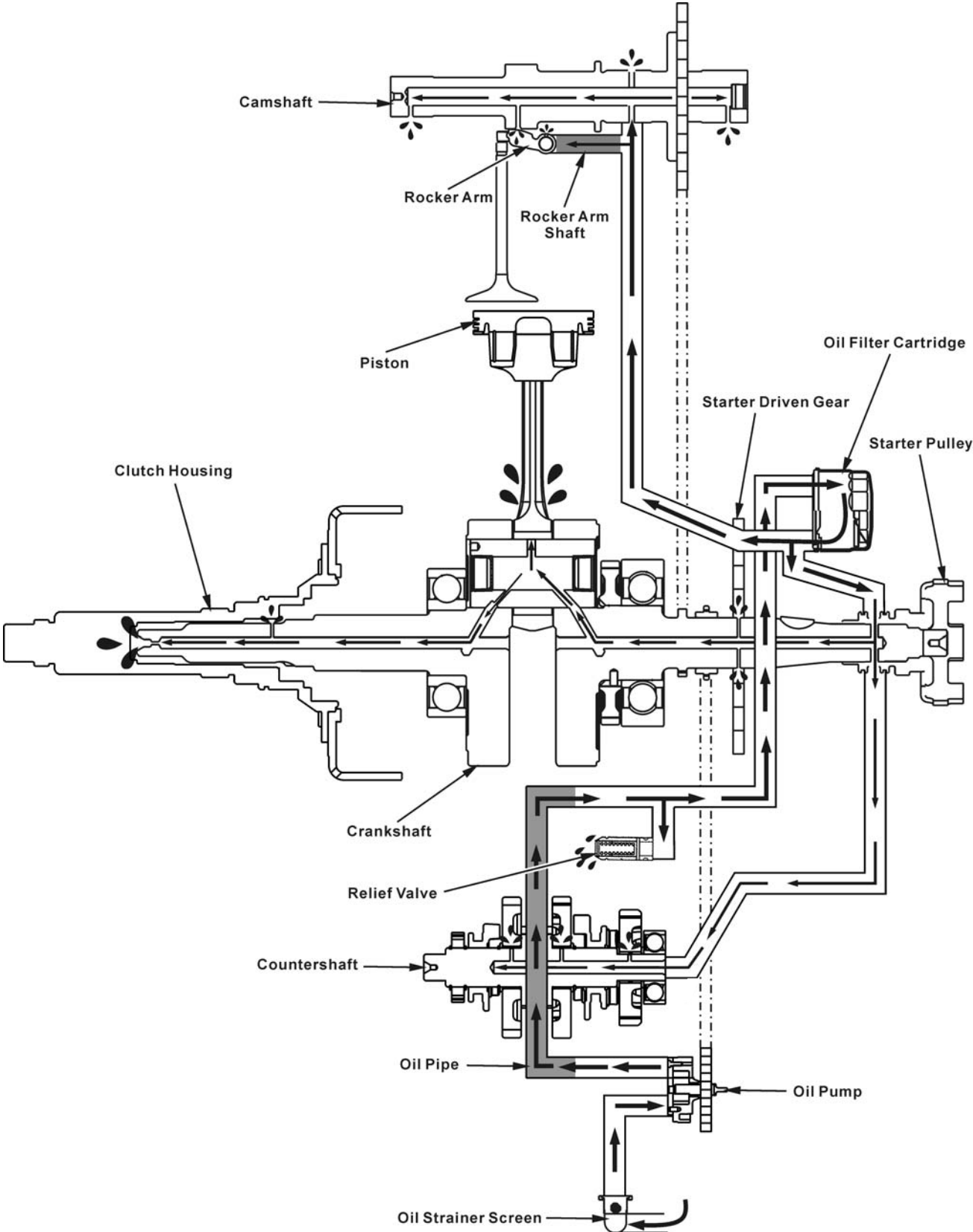

4. LUBRICATION SYSTEM

SERVICE INFORMATION

GENERAL INSTRUCTIONS

- The oil pump service may be done with the engine installed in the frame.
- When removing and installing the oil pump use care not to allow dust or dirt to enter the engine.
- If any portion of the oil pump is worn beyond the specified service limits, replace the oil pump as an assembly.
- After the engine has been installed check that there are no oil leaks and that oil pressure is correct.

SPECIFICATIONS

Unit: mm

ITEM		STANDARD	SERVICE LIMIT
Engine oil capacity	At draining	3 liter	—
	At disassembly	3.6 liter	—
Recommended engine oil		KYMCO 4-stroke oil or equivalent motor oil API service classification SJ Viscosity: SAE 5W-50	—
Oil pump rotor	Tip clearance	0.15 max	0.2
	Body clearance	0.15 – 0.2	0.25
	Side clearance	0.04 – 0.09	0.12

TORQUE VALUES

Oil pump screw	0.3 kgf-m (3 N-m)	
Oil strainer screen cap	1.5 kgf-m (15 N-m)	Apply oil to the threads and seating surface.
Oil filter cartridge	1 kgf-m (10 N-m)	Apply oil to the threads and seating surface.
Oil pipe bolt	3.5 kgf-m (35 N-m)	Apply oil to the threads and seating surface.

Special tool:

Oil seal & bearing drive A120E00014

4. LUBRICATION SYSTEM

TROUBLESHOOTING

Oil level low

- Oil consumption
- External oil leak
- Worn piston ring
- Incorrect piston ring installation
- Worn valve guide or seal

Oil contamination (White appearance)

- From coolant mixing with oil
 - Faulty water pump mechanical seal
 - Faulty head gasket
 - Water leak in crankcase

No oil pressure

- Oil level too low
- Oil pump drive chain broken
- Oil pump drive sprocket broken
- Oil pump damaged (pump shaft)
- Internal oil leak

Low oil pressure

- Pressure relief valve stuck open
- Clogged oil filter and strainer screen
- Oil pump worn or damaged
- Internal oil leak
- Incorrect oil being used
- Oil level too low

High oil pressure

- Pressure relief valve stuck closed
- Plugged oil filter, gallery, or metering orifice
- Faulty oil pump

Seized engine

- No or low oil pressure
- Clogged oil orifice/passage
- Internal oil leak
- Non-recommended oil used

Oil contamination

- Deteriorated oil
- Faulty oil filter
- Worn piston ring (White appearance with water or moisture)
 - Damaged water pump mechanical seal
 - Damaged head gasket
 - Oil relief not frequent enough

4. LUBRICATION SYSTEM

LUBRICATION CHECK HOLE

Remove the check hole plug/O-ring.
Start the engine.
Check the oil gushed from the hole. If not,
stop the engine immediately and determine
the cause.

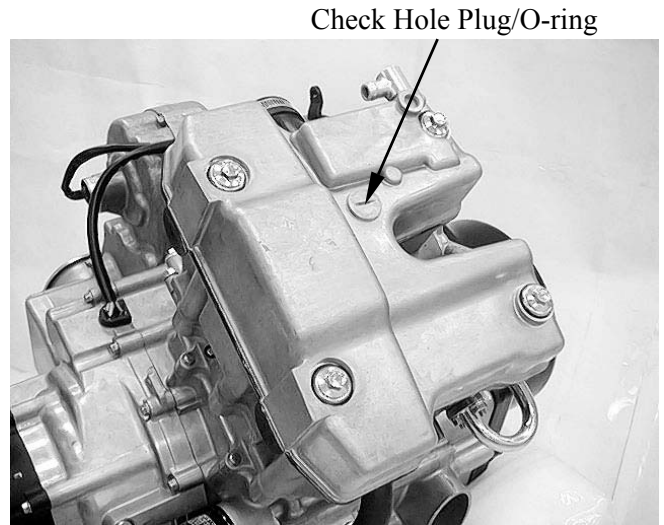

4. LUBRICATION SYSTEM

OIL PUMP REMOVAL/INSPECTION/ INSTALLATION

REMOVAL

Remove the flywheel and driven gear (refer to the “**STARTER CLUTCH REMOVAL/INSPECTION/INSTALLATION**” section in the chapter 19).

Remove the two bolts and oil pump drive chain guide.

Remove the two bolts and oil separator cover.

* When removing and installing the oil pump, use care not to allow dust or dirt to enter the engine.

Remove snap ring.

Remove the oil pump driven gear, then remove the oil pump drive chain.

Oil Pump Drive Chain Guide

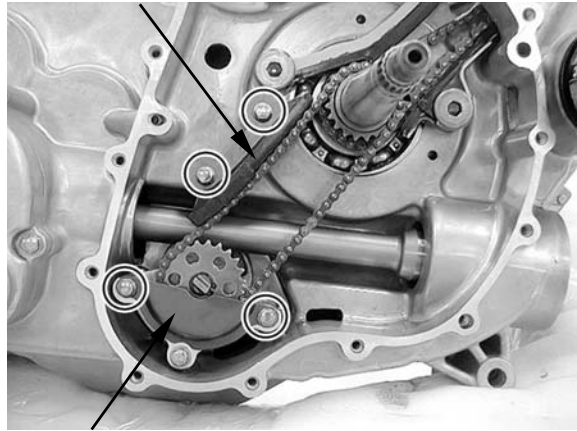

Oil Separator Cover

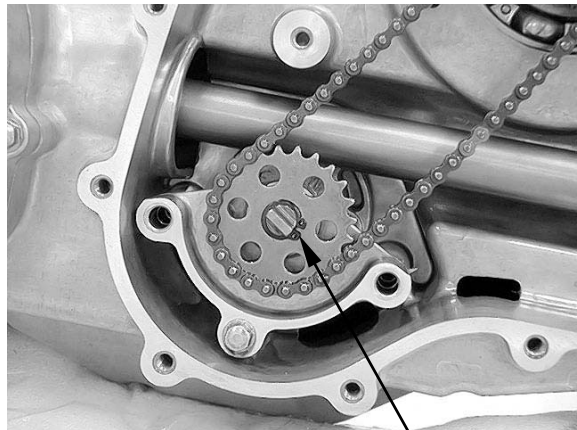

Snap Ring

Drive Chain

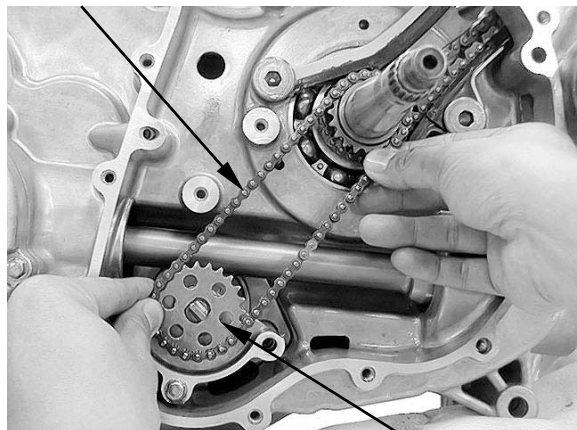

Driven Gear

4. LUBRICATION SYSTEM

Remove a bolt and then remove the oil pump holder.

Remove the two dowel pins.

Remove the two bolts and then remove the oil pump.

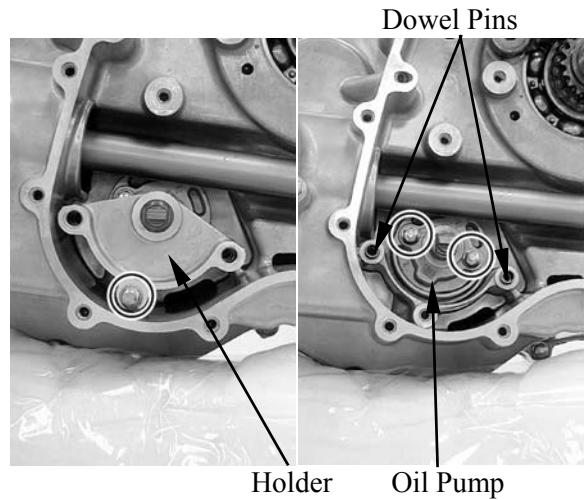

INSPECTION

Oil pump drive chain guide

Inspect the drive chain slipper surface of the drive chain guide for wear or damage.



INSTALLATION

Install the oil pump.

* Make sure the pump shaft rotates freely and arrow on the oil pump is upside.

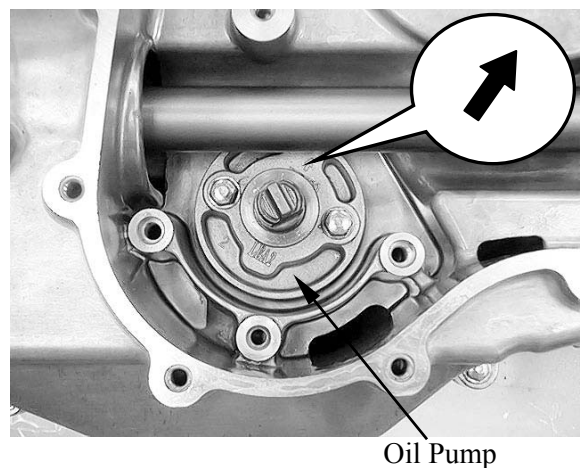

4. LUBRICATION SYSTEM

Install and tighten the two bolts securely.
Install two dowel pins

Install the holder, then install a bolt but do not tighten.

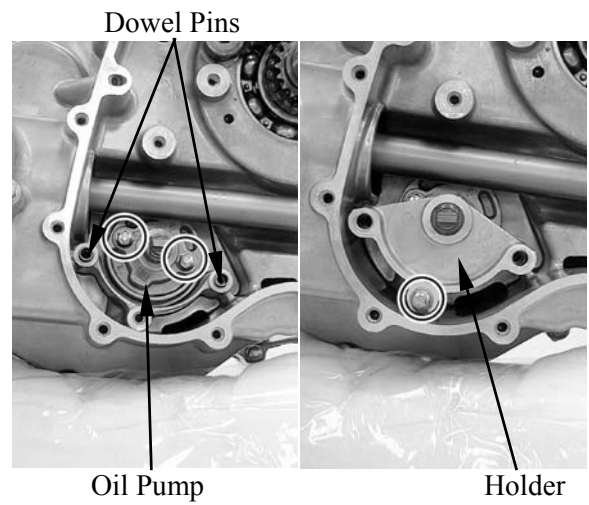

Install the driven gear and drive chain.

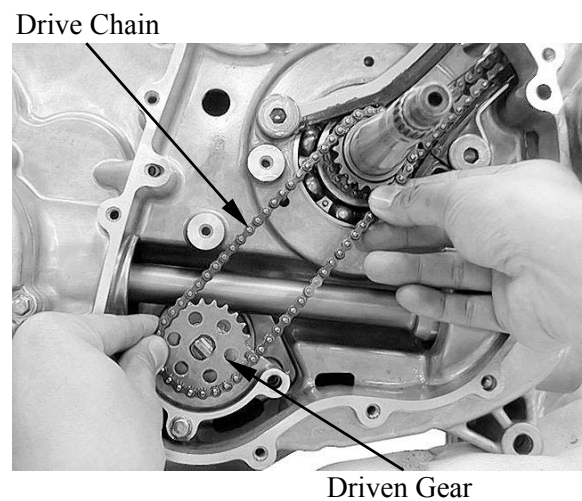

Install the snap ring.

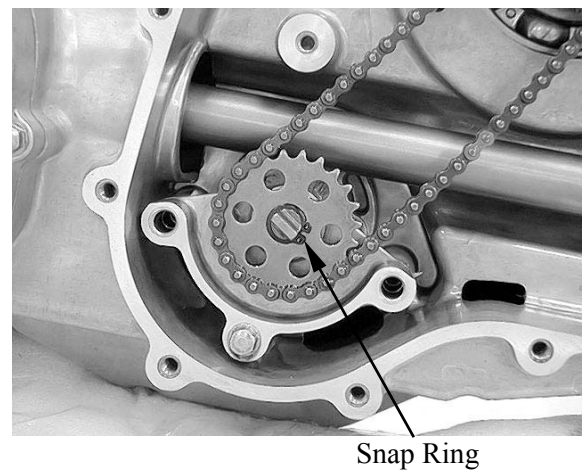

4. LUBRICATION SYSTEM

Install the chain guide, then install and tighten the two bolts securely.

Install the oil separator cover, then install and tighten the three bolts in a crisscross pattern in 2 or 3 steps.

Oil Pump Drive Chain Guide

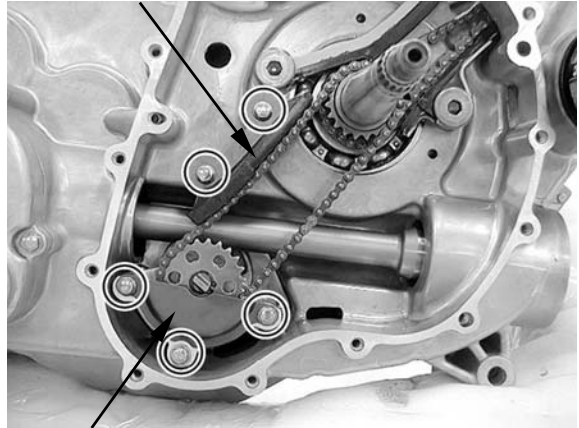

Oil Separator Cover

4. LUBRICATION SYSTEM

OIL PUMP DISASSEMBLY/INSPECTION/ ASSEMBLY

DISASSEMBLY

Remove the oil pump shaft.

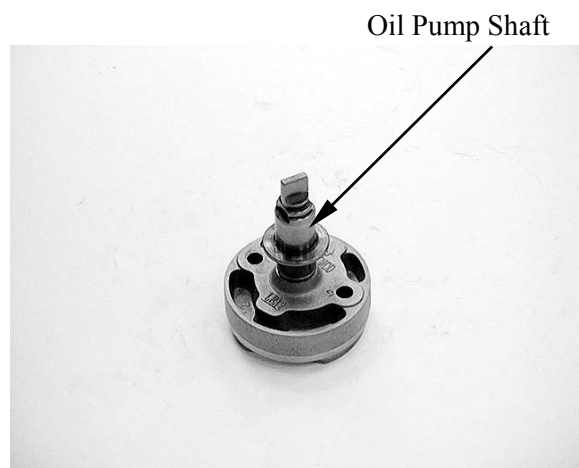

Remove the screw and oil pump cover.

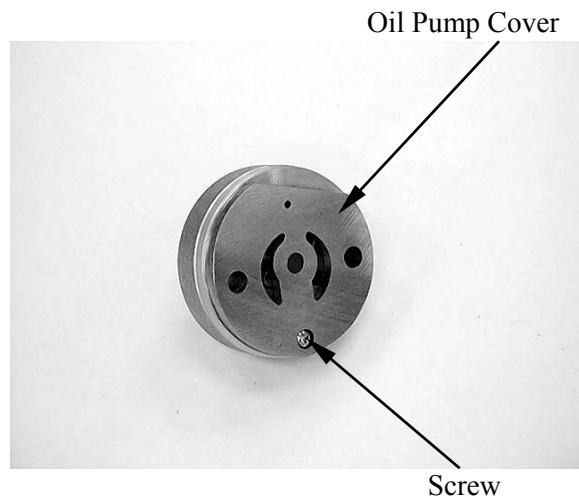

Remove the dowel pin, oil pump outer rotor and inner rotor.

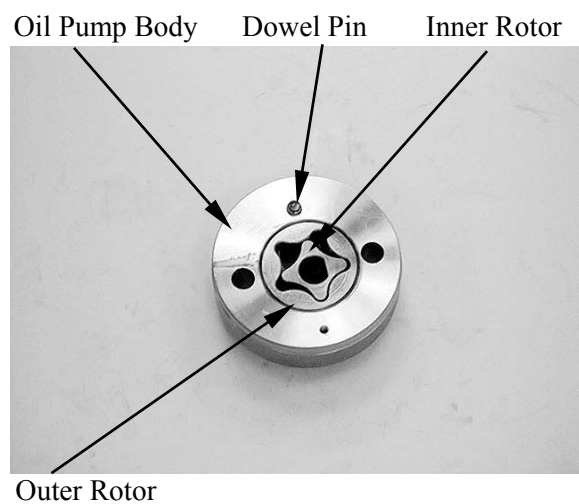

4. LUBRICATION SYSTEM

INSPECTION

Temporarily install the oil pump shaft.
Install the outer and inner rotors into the oil pump body.

Measure the tip clearance.

Service limit: 0.2 mm (0.008 in)

* Measure at several points and use the largest reading to compare the service limit.

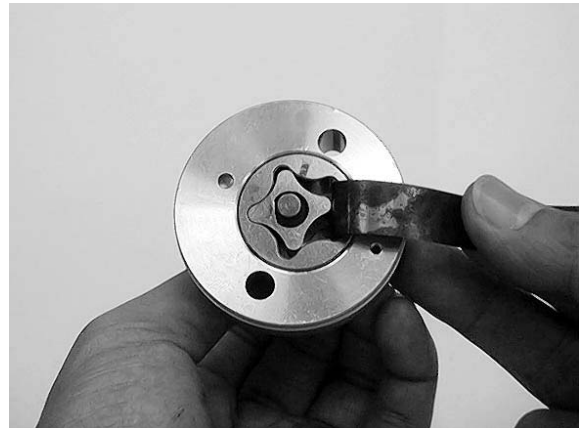

Measure the pump body clearance.

Service limit: 0.25 mm (0.01 in)

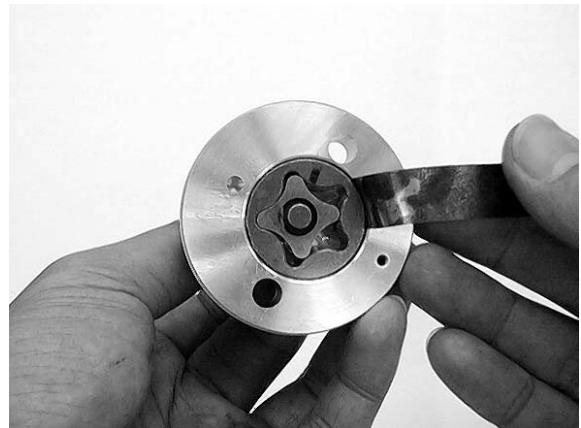

Measure the side clearance with the straight edge and feeler gauge.

Service limit: 0.12 mm (0.0048 in)

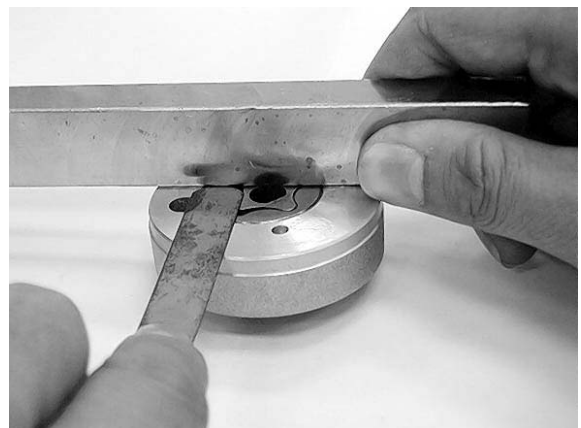

4. LUBRICATION SYSTEM

ASSEMBLY

Dip all parts in clean engine oil.

Install the outer rotor into the oil pump body.

Install the inner rotor into the outer rotor.

Install the oil pump shaft.

Install the dowel pin onto the oil pump body.

Install the oil pump cover onto the oil pump body by aligning the dowel pin.

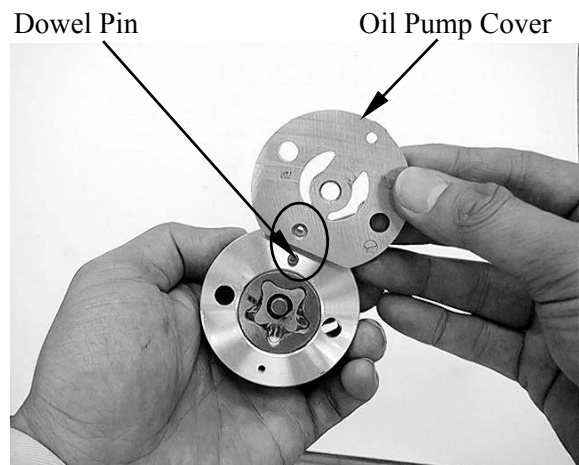

Install and tighten the screw to the specified torque.

Torqur: 3 N•m (0.3kgf•m, 2 lbf•ft)

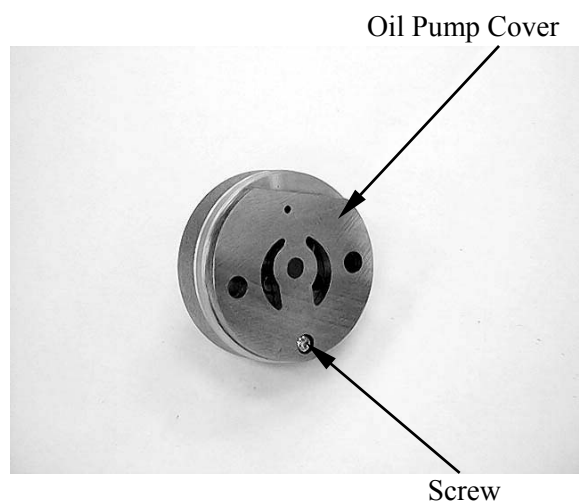

4. LUBRICATION SYSTEM

RIGHT CRANKCASE COVER DISASSEMBLY/ASSEMBLY

DISASSEMBLY

Remove the right crankcase cover (refer to the “ALTERNATOR STATOR REMOVAL/INSPECTION/INSTALLATION” in the chapter 17)

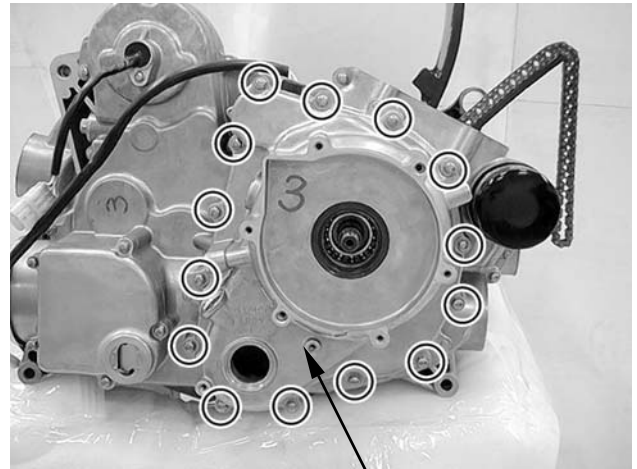

Right Crankcase Cover

Remove the oil seal.

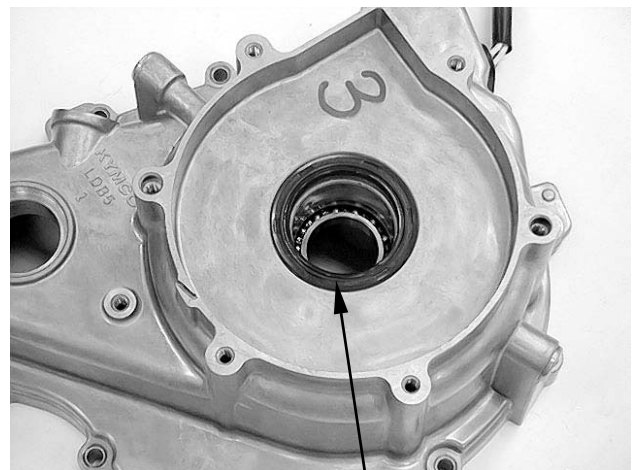

Oil Seal

Remove the snap ring.

Remove the bearing by using the special tool.

Special tool:

Oil seal & bearing drive A120E00014

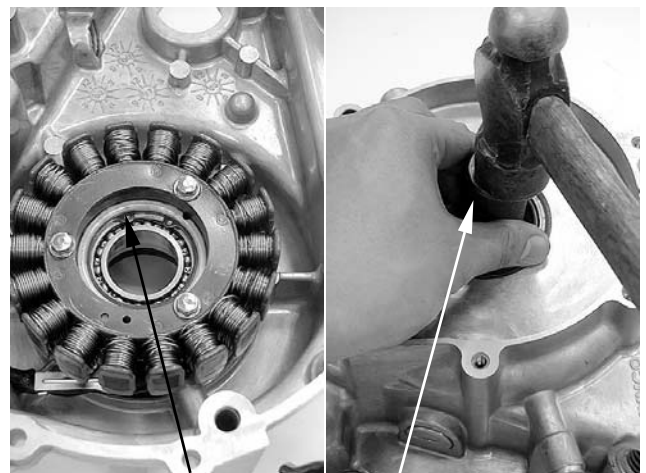

Snap Ring

Bearing Drive

4. LUBRICATION SYSTEM

ASSEMBLY

Install a new bearing by using the special tool.

Special tool:

Oil seal & bearing drive A120E00014

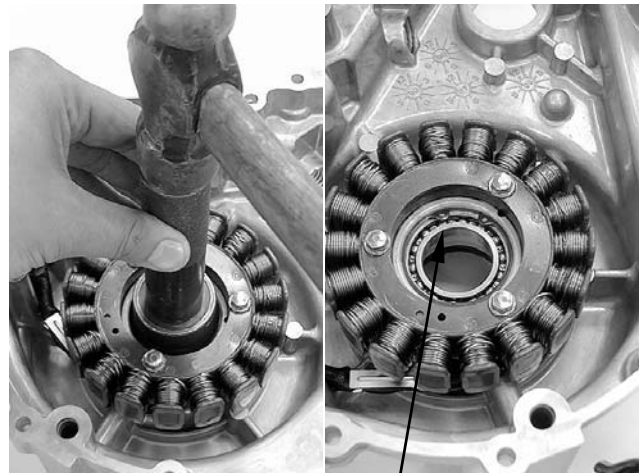

Bearing Drive

Snap Ring

Install a new oil seal.

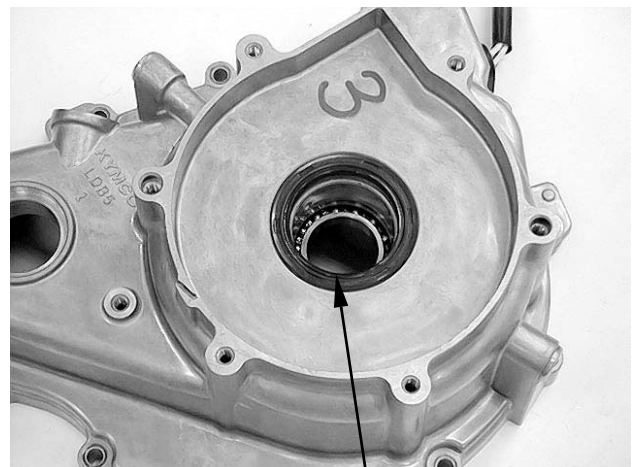

Oil Seal

4. LUBRICATION SYSTEM

OIL PRESSURE RELIEF VALVE

REMOVAL

Remove the right crankcase (refer to the “**RIGHT CRANKCASE REMOVAL/INSTALLATION**” section in the chapter 11).

Remove the pressure relief valve and O-ring from the right crankcase.

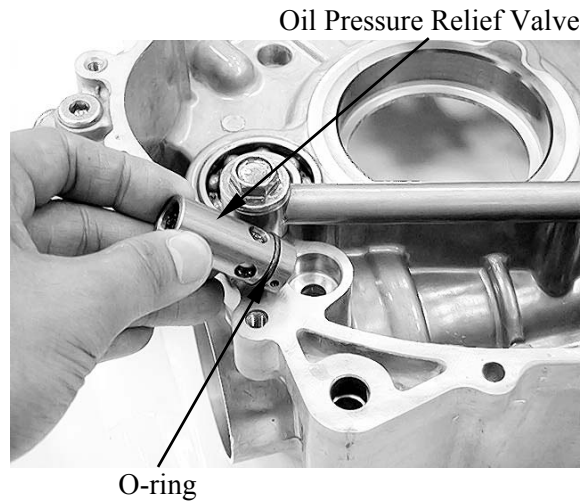

INSPECTION

Check the operation of the pressure relief valve by pushing on the piston.

INSTALLATION

Apply oil to a new O-ring and install the pressure relief valve groove, and install the relief valve to the right crankcase.

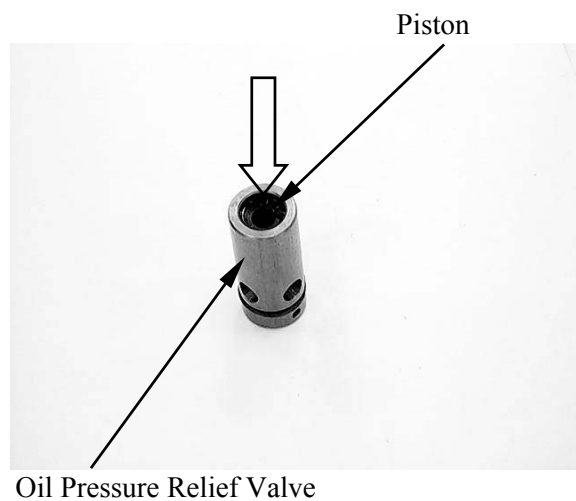

4. LUBRICATION SYSTEM

OIL PIPE REMOVAL/INSTALLATION

REMOVAL

Remove the two bolts, washers (on the oil pipe), oil pipe and washers (under oil pipe).

Bolts/Washers (on the oil pipe)

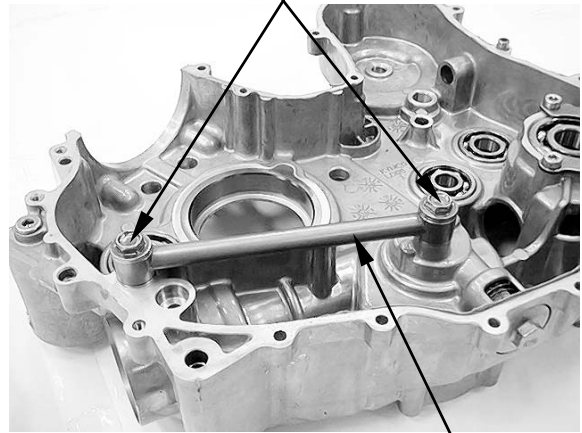

Oil Pipe/Washer (under oil pipe)

INSTALLATION

Install the inner washers on the right crankcase.

Washers

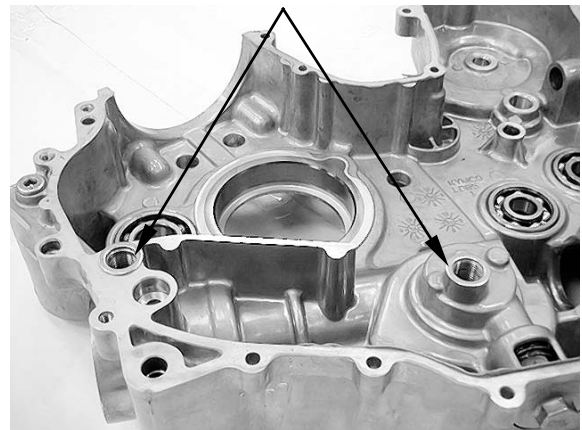

Install the oil pipe with the thick side face upward.

Thick Side

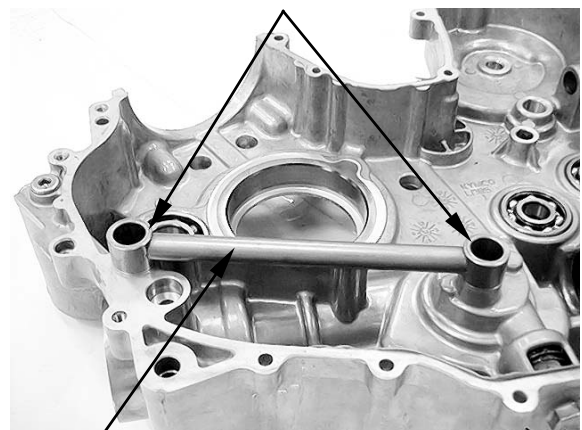

Oil Pipe

4. LUBRICATION SYSTEM

Apply clean engine oil to the bolts, then install the outer washers and two bolts. Tighten the two bolts to the specified torque.

Torque: 3.5 kgf-m (35 N-m, 25.2 lbf•ft)

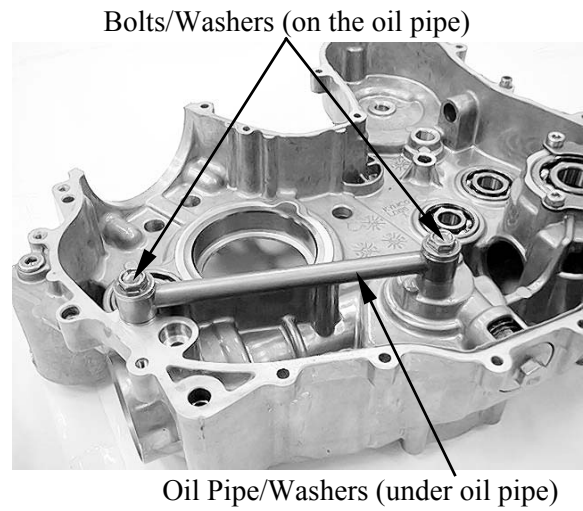

FUEL INJECTION SYSTEM

SERVICE INFORMATION-----	5- 1
SPECIFICATIONS -----	5- 2
INJECTION SYSTEM DIAGRAM -----	5- 3
PARTS LOCATION -----	5- 4
TROUBLESHOOTING-----	5- 8
SELF-DIAGNOSTIC PROCEDURES WITHOUT DIAGNOSTIC TOOL -----	5- 7
EFI SELF-DIAGNOSIS CHECK ENGINE LAMP (CELP) FAILURE CODES -----	5- 9
SELF-DIAGNOSIS RESET PROCEDURE -----	5-10
CELP FAILURE CODES LIST-----	5-11
TPS/ISC RESET -----	5-15
FUEL PUMP -----	5-16
FUEL PUMP RELAY-----	5-18
TILT SWITCH(ROLL SENSOR) -----	5-19
ELECTRONIC CONTROL UNIT (ECU)-----	5-20
FUEL INJECTOR -----	5-22
WTS SENSOR -----	5-24
THROTTLE BODY/T-MAP SENSOR/ISC/TPS -----	5-25
DIAGNOSTIC TOOL CONNECTOR-----	5-28
DIAGNOSTIC REPORT -----	5-29
DIAGNOSTIC TOOL OPERATION INSTRUCTIONS -----	5-30

SERVICE INFORMATION

GENERAL INSTRUCTIONS

- Scooter services can be done with the engine installed in the frame.
- Be sure to relieve the fuel pressure before fuel pump or fuel hose removal.
- Bending or twisting the control cables will affect operation and could cause the cables to stick or bind, resulting in loss of vehicle control.
- Work in a fully ventilated area. Smoking or allowing flames or sparks in the work area or where gasoline is stored can cause a fire or explosion.
- Do not apply the Carburetor Cleaners to the inside of the throttle body, which is coated with molybdenum.
- Do not snap the throttle valve from fully open to fully close after the throttle cable has been removed; it may cause incorrect idle speed.
- Do not loosen or tighten the painted bolts and screws of the throttle body. Loosening or tightening them can cause throttle and idle valve synchronization failure.
- Seal the cylinder head intake ports with tape or a clean towel to prevent dirt and debris from entering the intake ports after the throttle body has been removed.
- Do not damage the throttle body. It may cause incorrect throttle and idle valve synchronization.
- Do not take the fuel pump on the ground downward.
- Always replace the packing when the fuel pump is removed.
- The electronic fuel injection system is equipped with the self-diagnostic system. If the Check Engine Lamp “CELP” illuminate while riding, follow the self-diagnostic procedures to solve the problem.
- A faulty AFI problem is often related to poorly connected or corroded connectors. Check those connections before proceeding.
- When disassembling the fuel injection parts, note the location of the O-rings. Replace them with new ones upon reassembly.
- Do not disconnect the battery negative (-) or positive (+) cable while engine is running, it may cause ECU damage.
- **Do not disconnect or connect the ECU connector during the ignition switch “ON”; it may cause the ECU damage.**

SPECIFICATIONS

ITEM		SPECIFICATIONS
Throttle body identification number		PTA1
Idle speed		1400±100 rpm
Throttle grip free play		2~6 mm (1/16~1/4 in)
Fuel injector resistance (at 20°C/68°F)		10.6~15.9 Ω
Fuel pump resistance (at 20°C/68°F)	Float at full position	About 101 Ω
	Float at empty position	About 3 Ω
Fuel pump standard pressure (at 80 L/Hr)		300±10 kPa (3 Bar)
Water temperature sensor resistance	At -20°C/-4°F	28.6 KΩ
	At 40°C/104°F/20°C	1.46 KΩ/3.51 KΩ±10%
	At 100°C/212°F	0.176 KΩ
T-MAP sensor resistance(20°C)		1613~2544 Ω (1.2 pin)
Inductive ignition coil		Primary: 0.55~0.75 Ω
Throttle position sensor (TPS) resistance (at 20°C/68°F)		3500~6500 Ω (1.2 pin)
Crank position sensor resistance		96~144 Ω
Roll sensor voltage	Standard	0.4~1.4 V
	Over 65° (fall down)	3.7~4.4 V

INJECTION SYSTEM DIAGRAM

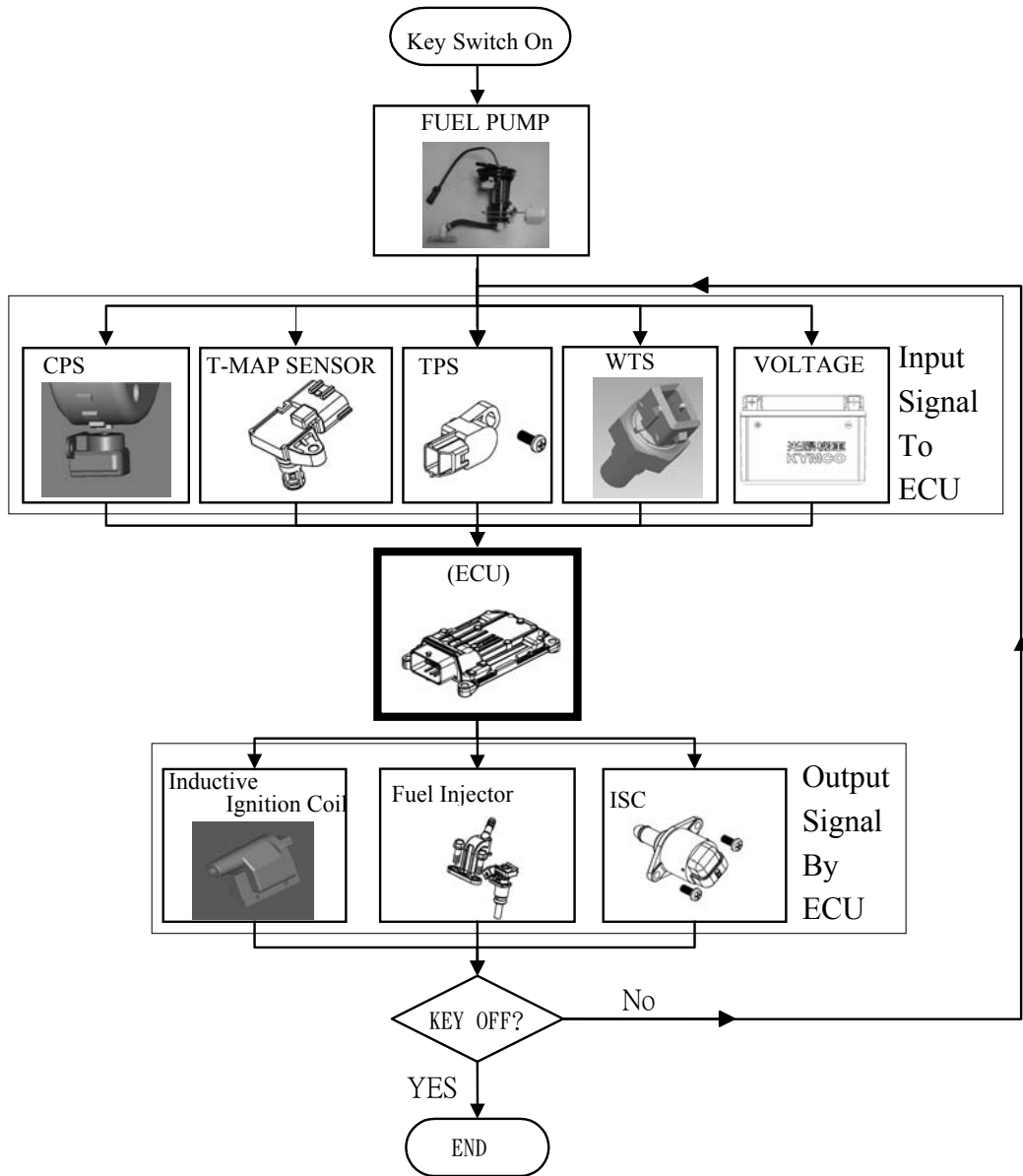

PARTS LOCATION

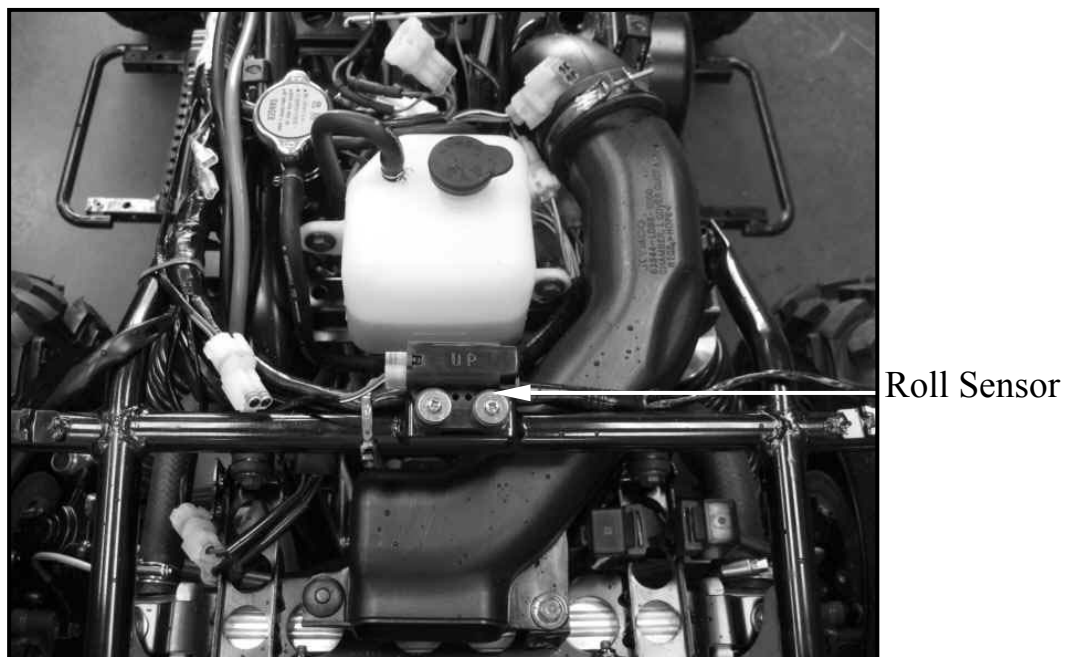

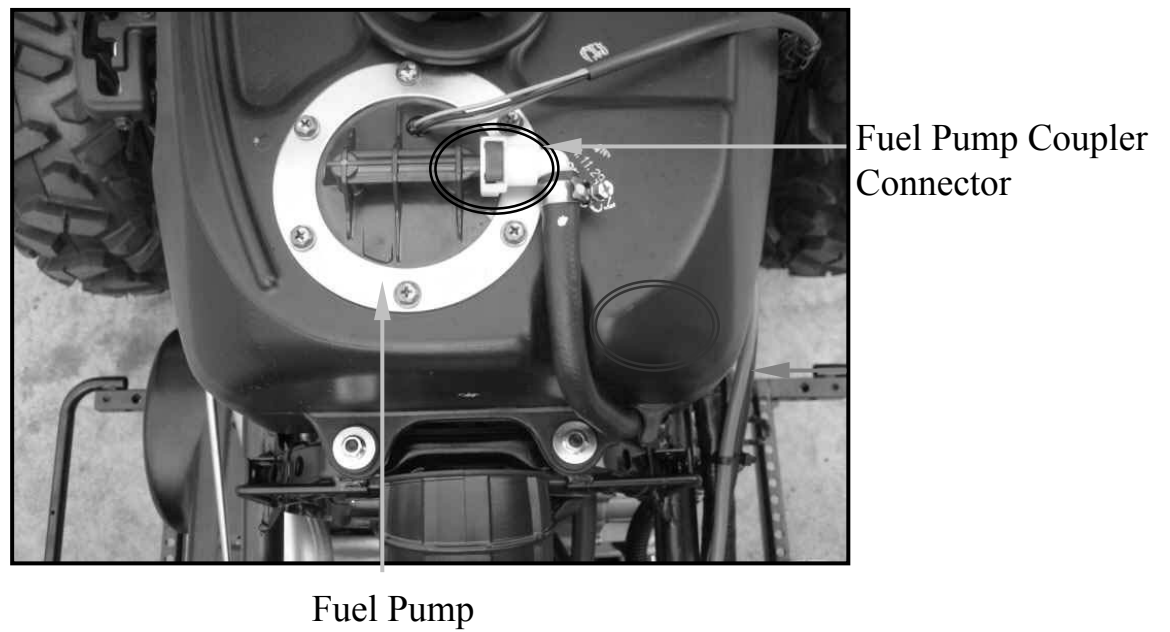
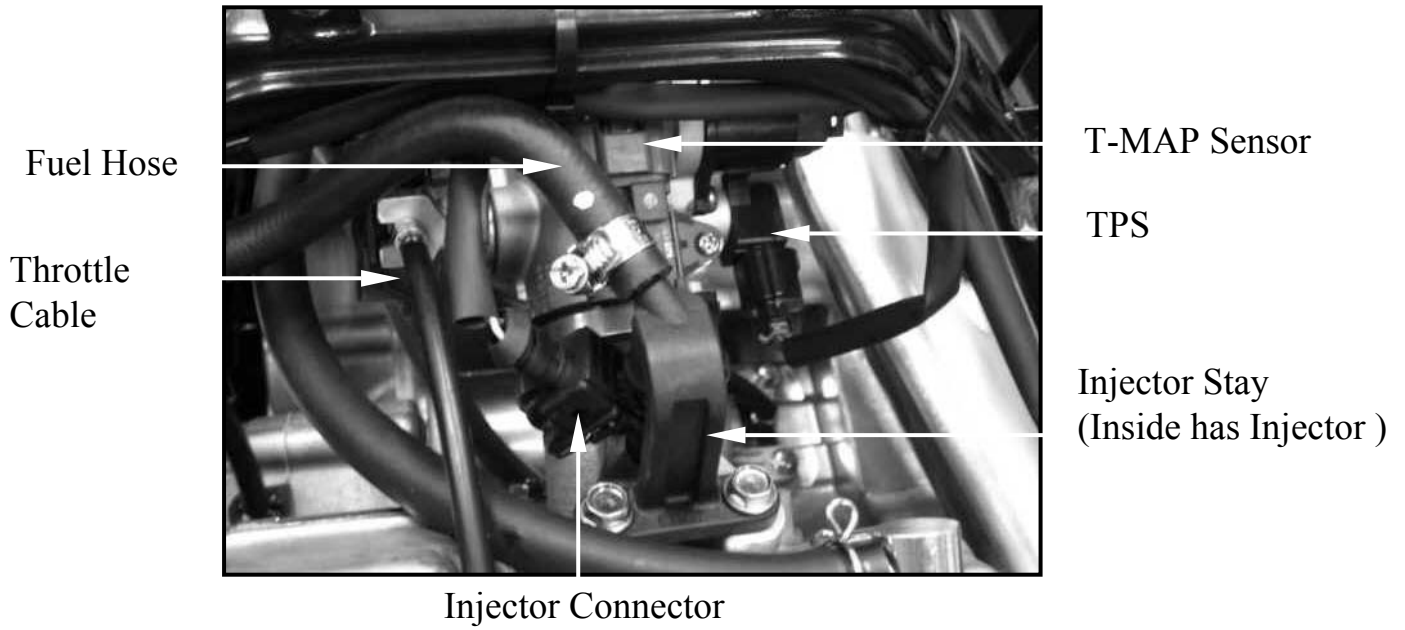

5. FUEL INJECTION SYSTEM

Inductive
Ignition
Coil

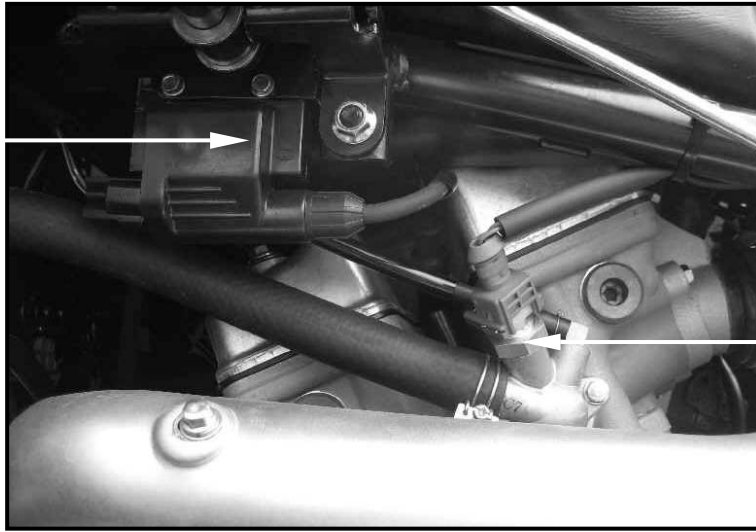

WTS

Fuse box
Fan/Starter(2)
Relay

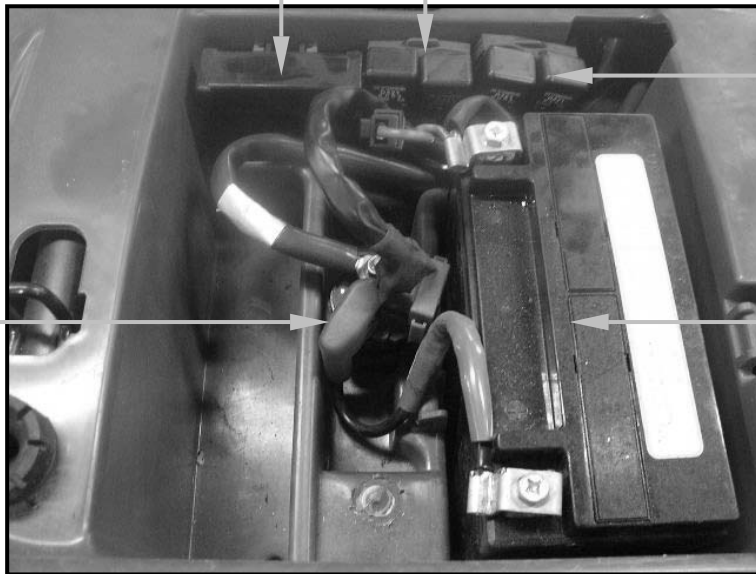

ECU sw power relay
Fuel pump relay

Starter Relay1

Battery

5. FUEL INJECTION SYSTEM

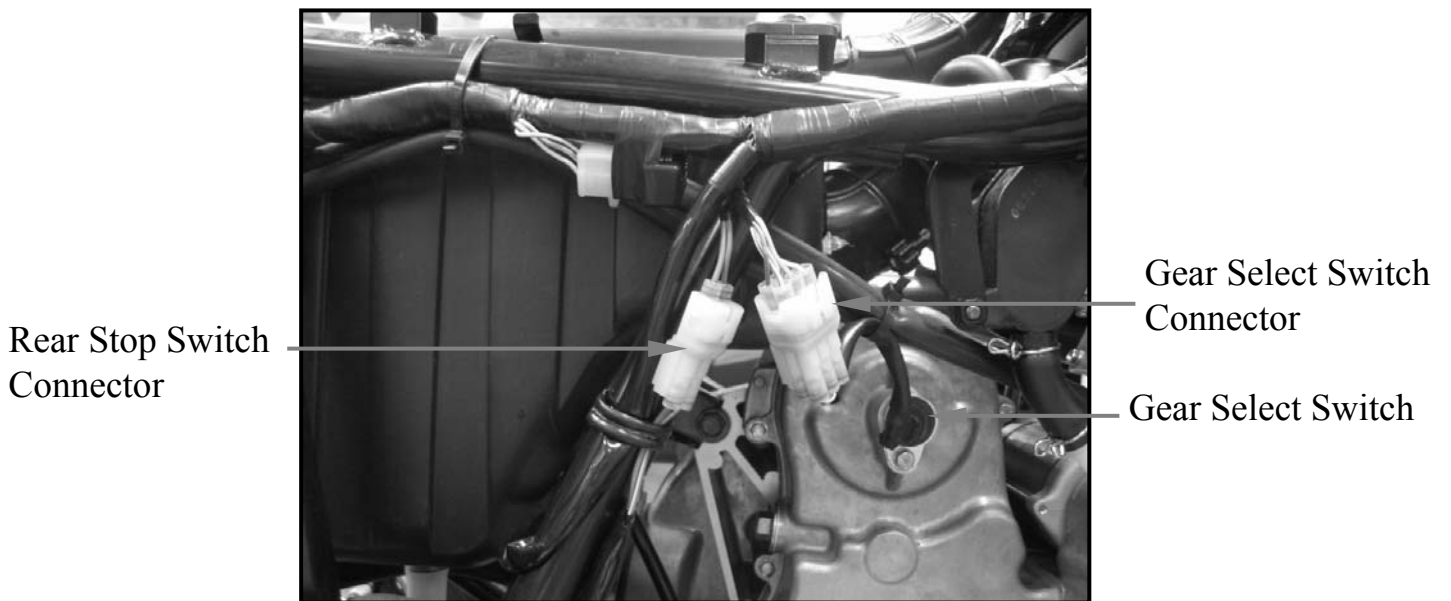
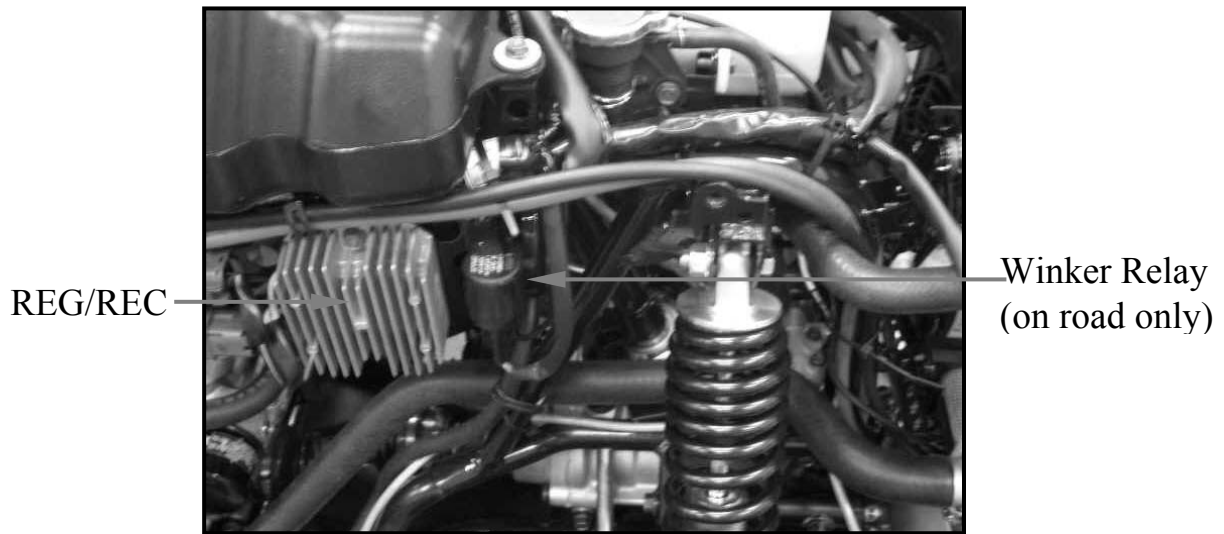

TROUBLESHOOTING

Engine won't start

- Battery voltage too low
- Fuel level too low
- Pinched or clogged fuel hose
- Faulty fuel pump operating system

- Clogged fuel injector
- Faulty spark plug or wrong type
- Clogged Airflow Bypass Valve
- Wet spark plug

Engine stall, hard to start, rough idling

- Intake air leak
- Fuel contaminated/deteriorated
- Pinched or clogged fuel hose
- Idle speed miss adjusted
- Wet spark plug

Backfiring or misfiring during acceleration

- Ignition system malfunction

Poor performance (drive ability) and poor fuel economy



- Pinched or clogged fuel hose
- Faulty fuel injector

CHECK ENGINE LAMP (CELP)

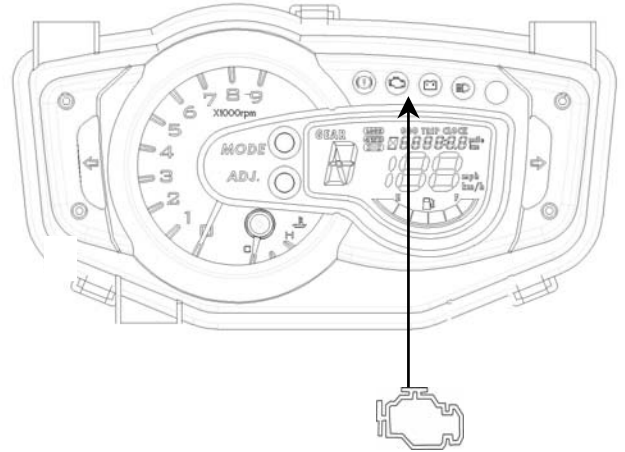
- Turn the ignition switch to “ON” position
- The CELP indicator will be lighting until the engine starting
- If no failure code, the CELP indicator would be turned off.
- If the failure code happens, the CELP indicator would be turned on



CELP (Check Engine Lamp)

- Turn the ignition switch to “ON” position
- The indicator will be lighting until the engine starting
- If no failure code, the  indicator would be turned off.
- If the failure code happens, the  indicator would be turned on

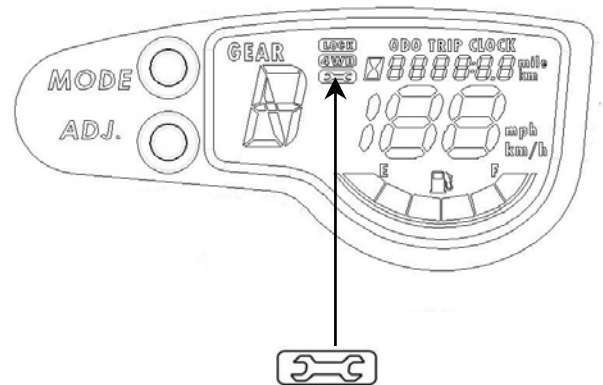

EFI system electric parts fault indicator

5. FUEL INJECTION SYSTEM

How To Show Failure Code

You can read the failure code by Diagnostic tool.



CELP FAILURE CODES LIST

Blinks	Failure Codes	Fault description	Priority	Fault management
1	P0217	Engine temperature overheat	1	1.Slow down the vehicle and go to workshop for checking immediately. 2.Confirm if the engine temperature sensor or electric circuit is abnormality.
2	P0335	Crankshaft position sensor or circuit malfunction	2	1.Check if the connector of crankshaft position sensor is loosen. 2.Check if the Rotor is align with Crankshaft position sensor during the crankshaft running.
3	P1120	Throttle position sensor setting value problem	2	1.Make sure if the connector of Throttle position sensor is connected correctly. 2.Check if the Throttle position sensor is adjusted.
4	P1121	Throttle position sensor output range problem	2	1.Make sure if the connector of Throttle position sensor is connected correctly. 2.Check if the Throttle position sensor is adjusted.

5. FUEL INJECTION SYSTEM

Blinks	Failure Codes	Fault description	Priority	Fault management
5	P1122	Throttle position sensor movement speed problem	2	1. Make sure if the connector of Throttle position sensor is connected correctly. 2. Check if the Throttle position sensor is adjusted.
6	P0560	Battery voltage malfunction	1	1. Check if the battery voltage is lower or higher. 2. Check if the charge system is malfunction.
7	P0110	Intake air temperature circuit malfunction	2	Inlet air temperature sensor or electric circuit malfunction
8	P0410	Idle air valve circuit malfunction	2	1. Check if the connector of Idle air valve loosen. 2. Check if the resistance of valve is normal.
9	P0505	Idle speed volume control range problem	3	1. Check if the ISC steps range over 65 steps.
10	P0251	Injector or electric circuit problem	2	1. Check if the connector of Injector is loosen. 2. Check if the ECU send signal to Injector. 3. Check if the power source and resistance of Injector are malfunction.

5. FUEL INJECTION SYSTEM

Blinks	Failure Codes	Fault description	Priority	Fault management
11	P0350	Ignition coil or electric circuit malfunction	2	1. Check if the connector of ignition coil is loosen. 2. Check if the ECU send signal to Ignition coil. 3. Check if the power source and resistance is malfunction
12	P0230	Fuel pump relay or electric circuit malfunction	2	1. Check if the connector of relay is loosen. 2. Check if the ECU send signal to relay. 3. Check the fuel pump relay resistance
13	P0219	Engine speed is over than top speed	2	Check if the belt of CVT is broken.
14	P1560	Sensor don't receive power source from ECU	2	1. Check if ECU output DC5V to sensor. 2. Check if the power source of all sensor is DC5V. 3. Replace a new ECU if the CELP still blinks even the output power source of ECU is normal.
15	P0700	Engine starting speed exceed CVT speed limited	2	Don't use it at present.
16	P0115	Engine temperature sensor or electric circuit malfunction	2	1. Check if the connector of sensor is loosen. 2. Check if ECU pin is broken. 3. Check if the resistance of sensor is malfunction.
17	P1561	Temperature gauge electric circuit malfunction	2	Don't use it at present.

5. FUEL INJECTION SYSTEM

Blinks	Failure Codes	Fault description	Priority	Fault management
18	P0650	CELP electric circuit malfunction	3	<ol style="list-style-type: none">1. Check if the lamp of CELP is broken.2. Check if wires of CELP is broken.
21	P0105	Atmospheric Pressure Sensor/Circuit Malfunction	2	<ol style="list-style-type: none">1. Check if the connector of sensor is loosen.2. Check if ECU pin is broken.3. Check if voltage of sensor is fit in specification.
22	P0110	Roll sensor or electric circuit malfunction	2	<ol style="list-style-type: none">1. Check if the sensor installation direction is correct.2. Check if voltage of sensor is fit in specification.3. Check if ECU pin is broken.

TPS/ISC RESET

- If close or open the throttle grip randomly, the ECU may record the incorrect TPS when the ECU or the throttle body has been reinstalled. It can cause hard to start engine or idling speed is not smooth when engine installation.
- ISC has a motor inside, which controls ISC valve to obtain smooth idling speed. The ECU may record the incorrect ISC position during the engine speed isn't working when the ECU or the throttle body has been reinstalled. It can cause engine stop, hard to start engine or rough idling speed.

The throttle position sensor (TPS) and idle air bypass valve (ISC) have to be reset when throttle body, T-MAP, TPS, ISC or ECU has been reinstalled.

TPS/ISC RESET PROCEDURE

Start the engine till engine temperature to 85°C over on idle condition.

ECU will automatic learn engine new condition.

FUEL PUMP

INSPECTION

Put the side stand up and the engine stop switch is at "RUN"

Disconnect the fuel pump/fuel unit connector.

Connect the multimeter (+) probe to the Gray terminal and the multi-meter (-) probe to the Gray terminal.

Turn the ignition switch to "ON" and measure the voltage between the terminals.

It should be shown the current battery voltage for a few seconds.

If there is still battery voltage, replace the fuel pump.

If there is not any battery voltage, inspect the following:

- Fuse
- Fuel pump relay
- ECU

Measure the resistance between the both Gray terminals of the fuel pump side connector.

Standard (at 20°C/68°F): About 10.7 Ω

Fuel level sensor inspection

Measure the resistance between the Gray and Gray terminals of fuel pump side connector.

Standard (at 20°C/68°F):

Float at full position	About 101Ω
Float at empty position	About 3 Ω

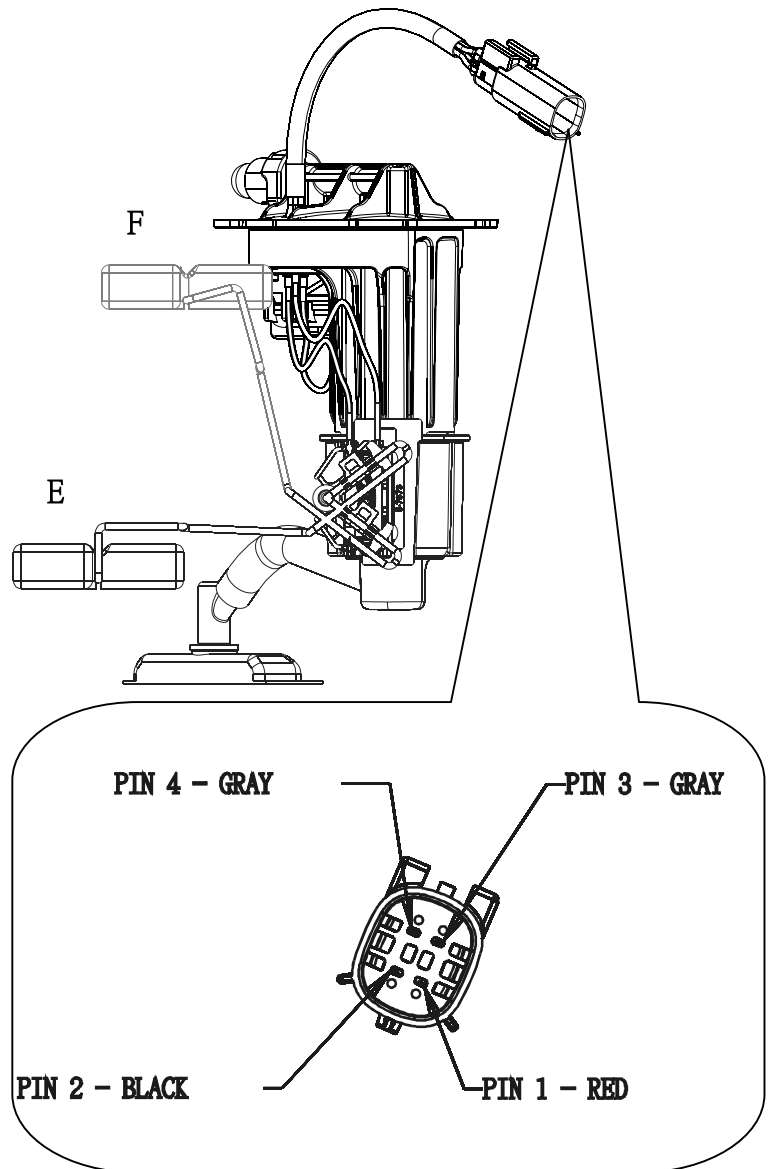

5. FUEL INJECTION SYSTEM

REMOVAL

Disconnect the connector and fuel band from the fuel pump.

Remove the six screws onto the fuel pump.

Remove the fuel pump and O-ring.

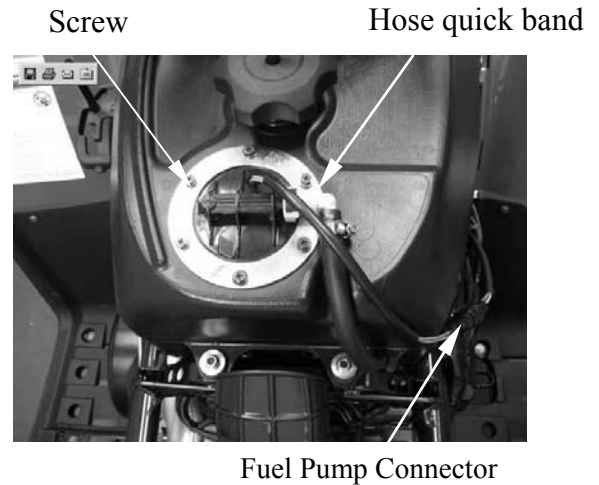

INSTALLATION

Replace a new O-ring on the fuel tank.

Don't damage the fuel pump wire and ensure the connector rearward carefully.

Torque: 0.35 kgf-m (3.5 N-m, 2.5 lbf-ft)

FUEL OUTPUT PRESSURE INSPECTION

Turn the key to the OFF position.

Use the fuel hose clamp.

Disconnect the fuel hose from the fuel injector.

Connect the fuel pressure gauge.

Turn the key to the ON position.

Check the fuel pressure.

Standard:3.0 Bar

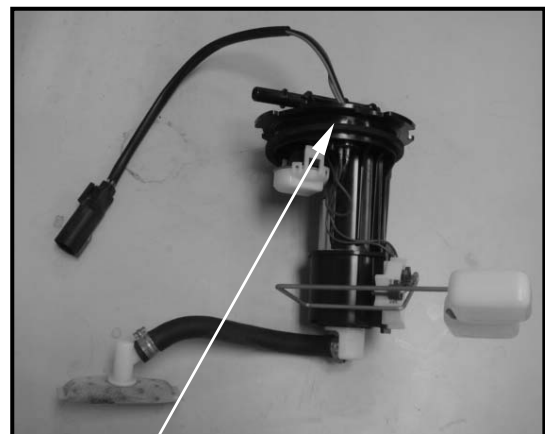

* **If the fuel output pressure is less than 3.0 bar, may fail to start the engine or in trouble in case of riding.**

5. FUEL INJECTION SYSTEM

FUEL PUMP RELAY

INSPECTION

Remove the fuel pump relay.
Connect the ohmmeter to the fuel pump relay connector terminals.

Connection: R/L-B/R

Connect 12 V battery with the fuel pump relay connector.

Connection: R/Y-O/R

There should be continuity only when 12 V battery connected.

If there is not continuity when the 12 V battery is connected, replace a fuel pump relay.

REMOVAL

Disconnect the fuel pump relay connector and remove it from frame.

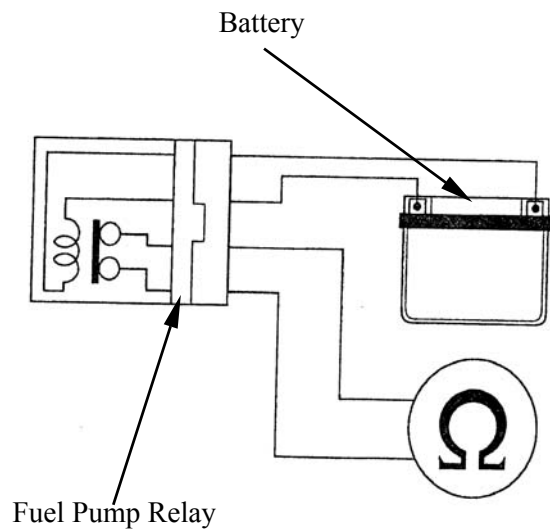

Fuel Pump Relay

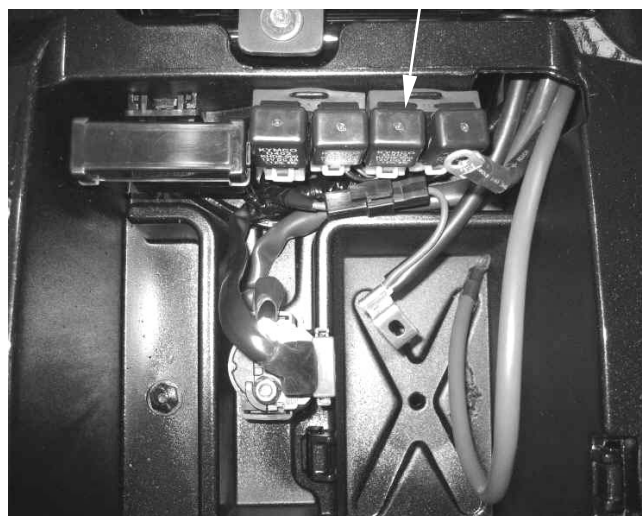

TILT SWITCH(ROLL SENSOR)

INSPECTION

Support the ATV level surface.

Turn the ignition switch to “OFF”

Remove the screws, washers and tilt switch.

* Do not disconnect the tilt switch connector during inspection.

Place the tilt switch vertical as shown, and turn the ignition switch to “ON”.

Measure the voltage between the following terminals of the tilt switch connector with the connector connected.

Terminal	Normal
V/R (+) -G(-)	5 V (ECU voltage)
B/W (+) - G(-)	0.4~1.4 V

Incline the tilt switch 65 ± 10 degrees to the left or right with the ignition switch turned to “ON”.

Measure the voltage between the following terminals of the tilt switch connector with the connector connected.

Terminal	Normal
V/R (+) - G (-)	5 V (ECU voltage)
B/W (+) - G(-)	3.7~4.4 V

If repeat this test, first turn the ignition switch to “OFF”, then turn the ignition switch to “ON”.

REMOVAL/INSTALLATION

Disconnect the connector and remove two screws.

Remove the Tilt switch.

Installation is in the reverse order of removal.

* Install the tilt switch with its “UP” mark facing up.

Tighten the mounting screws securely.

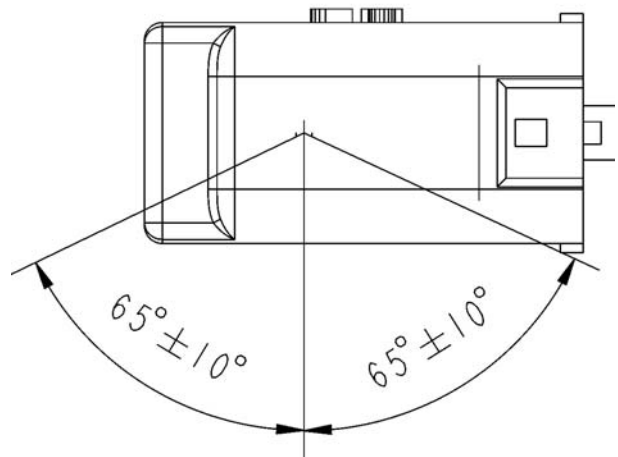
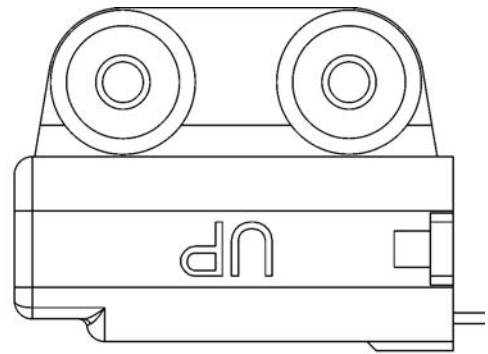

Roll Sensor

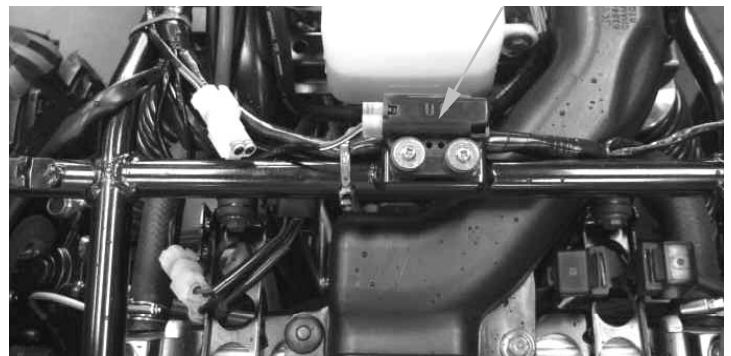

5. FUEL INJECTION SYSTEM

ELECTRIC CONTROL UNIT (ECU)

REMOVAL/INSTALLATION

- * Do not disconnect or connect the ECU connector during the ignition switch "ON"; it may cause the ECU damaged.
- The throttle position sensor (TPS) and idle air bypass valve (ISC) have to be reset when throttle body, MAP, TPS, ISC or ECU has been reinstalled.



ECU Connector

Disconnect the ECU connector and remove the ECU from the frame.

Installation is in the reverse order of the removal.

ECU connector remove procedure
(Same as DOWNTOWN 125i)

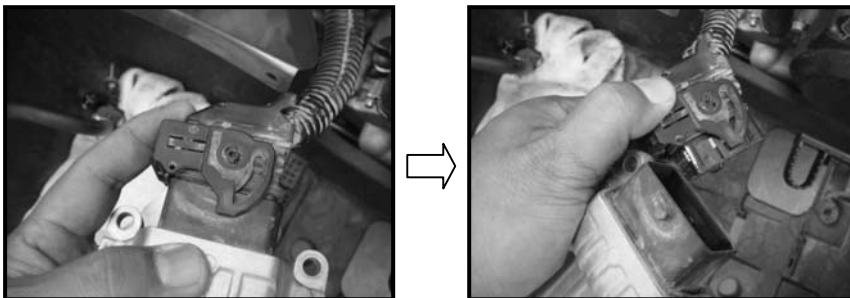
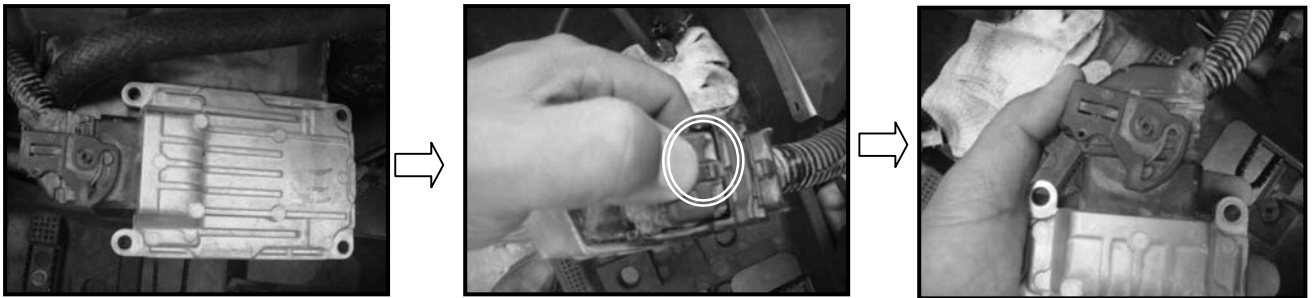

ECU connector install procedure

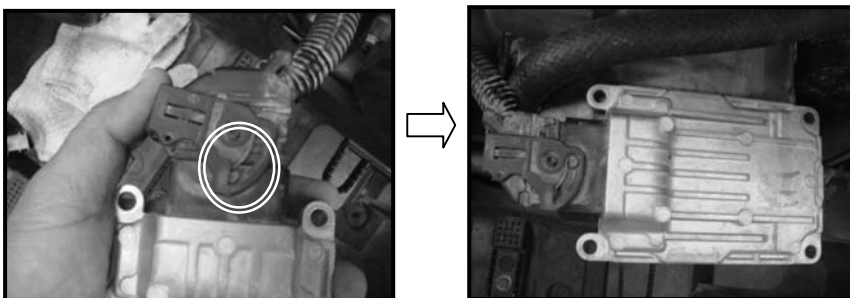

5. FUEL INJECTION SYSTEM

INSPECTION

Outlook checking

Checking for ECU pin(1-48) if has damage.

Checking for ECU part number if is correct.

3920A-ALC1-E00 is correct-on road

3920A-AAA5-900 is correct-off road

Voltage inspection

Connect the meter (+) probe to the B4(R/W)wire and the meter (-) probe to the M3(G/B) wire to measure the voltage

MAP content (edition issue no.)



Performance confirmed



V/R	(A1)	SENSOR POWER
	(A2)	
	(A3)	
BR/L	(A4)	+12V SWITCH POWER
B/L	(B1)	CAN-HIGH (+)
	(B2)	
L/R(2)	(B3)	ENG CHECK
R/W	(B4)	+12V MEMORY
W/L(2)	(C1)	CAN-LOW (-)
	(C2)	
V/G(1)	(C3)	SENSOR GROUND (1)
BR/W(1)(C4)		ISC (STEPB2)
L/Y	(D1)	CRANK ANGLE (+)
B/W	(D2)	TILT SENSOR
GR/L	(D3)	ISC (STEPA1)
G/O	(D4)	ISC (STEPA2)
G/W(1)	(E1)	CRANK ANGLE (-)
W/R	(E2)	GEAR-D (L)
	(E3)	
G/B(2)	(E4)	ISC (STEPB1)
	(F1)	BRAKE SWITCH
O/B	(F2)	MANIFOLD PRESSVRE
BR/W(2)(F3)		AIR INTAKE TEMP
G/L	(F4)	ENGINE COOLANT TEMP
	(G1)	LHCA-ENGINE STOP SW
V/G(2)	(G2)	SENSOR GROUND (2)
V/B	(G3)	THROLLER POSITION
	(G4)	
G/L(2)	(H1)	K-LINE
W/B(2)	(H2)	GEAR-B (H)
V	(H3)	SPEED SIGNAL
LG/R	(H4)	GEAR-C (N)
B/R	(J1)	FUEL RELAY
	(J2)	DIFF-LOCK INPUT
L/R	(J3)	GEAR-A (R)
	(J4)	OVERRIDE
B/O	(K1)	IGNITION RELAY
L(2)	(K2)	FAN RELAY
W/L(1)	(K3)	4WD INPUT
	(K4)	
R/Y	(L1)	+12V SWITCHED POWER
	(L2)	
	(L3)	STARTER SOLENOID
W/R(2)	(L4)	INJECTOR
B/Y	(M1)	IGNITION COIL
	(M2)	
G/B(1)	(M3)	GROUND (1)
G/B(1)	(M4)	GROUND (2)

EFI ECU (M3 C)
48P

FUEL INJECTOR

INSPECTION

Disconnect the fuel injector connector.
Measure the resistance between 2 pins of the fuel injector connector.

Standard: 10.6~15.9 Ω (at 20°C/68°F)



REMOVAL

Disconnect the connector from the fuel injector.
Remove the bolts of the fuel injector.
Take out of the fuel pipe and fuel injector from the Inlet pipe.
Remove the fuel injector from the fuel pipe.

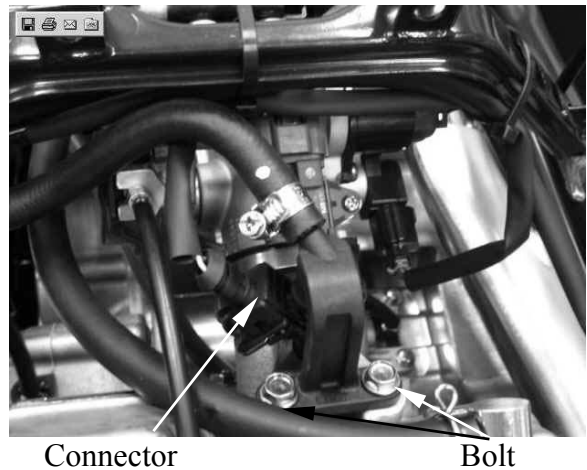

*

Ensure the fuel pipe without any pressure, then remove the fuel injector.
STEP 1: Disconnect the fuel pump relay or fuel pump connector.
STEP 2: Turn the key to the ON position. Starting the engine till the engine stop working.

5. FUEL INJECTION SYSTEM

INSTALLATION

Apply the engine oil to a new O-ring.
Install the fuel injector into the fuel pipe.
Ensure the clip of the fuel injector inserted into the groove of the fuel pipe.

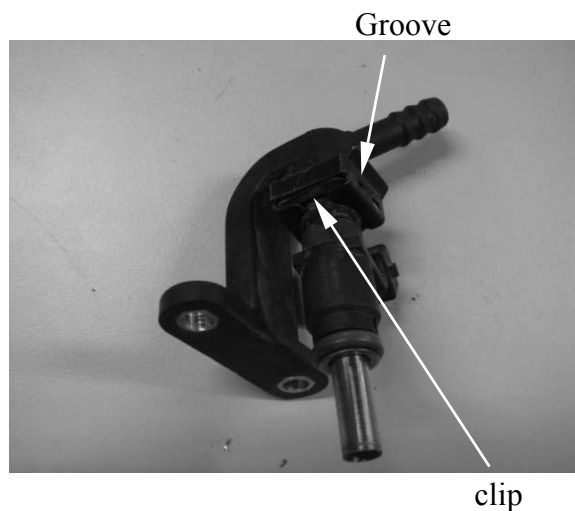

Install the fuel pipe into the intake manifold

Be careful not to damage the O-ring.
Tighten the fuel pipe mounting bolts.



FUEL INJECTOR CLEANING

PROBLEM

1. Fuel Injector cannot output the fuel.
2. The Injector injection time (ms) is shorter or longer.

Standard: See the KYMCO Diagnostic report

ANALYSIS

Injector block (With some carbons).

TROUBLESHOOTING

1. Use the specified injector cleaner.
2. Pouring the liquid of injector cleaner until half container.
3. Connect the battery as picture.
4. The injector cleaner with the flash relay.
5. Keeping the fuel Injector operation.
6. Waiting for 20~30 minutes.
7. Cleaning the carbons completely.

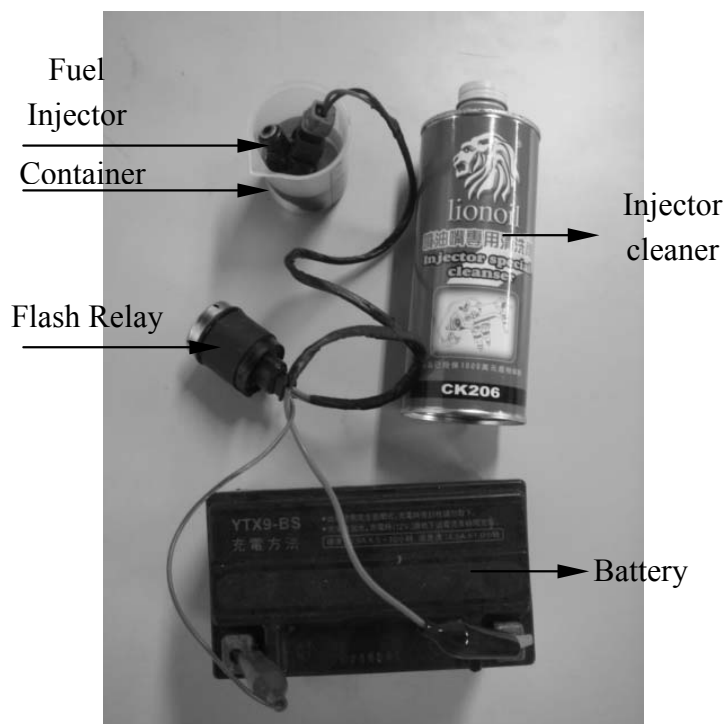

WTS SENSOR (Water Temperature Sensor)

REMOVAL / INSTALLATION

Drain the coolant from the cooling system.
Disconnect the WTS sensor connector from the sensor.
Remove the WTS sensor and O-ring.

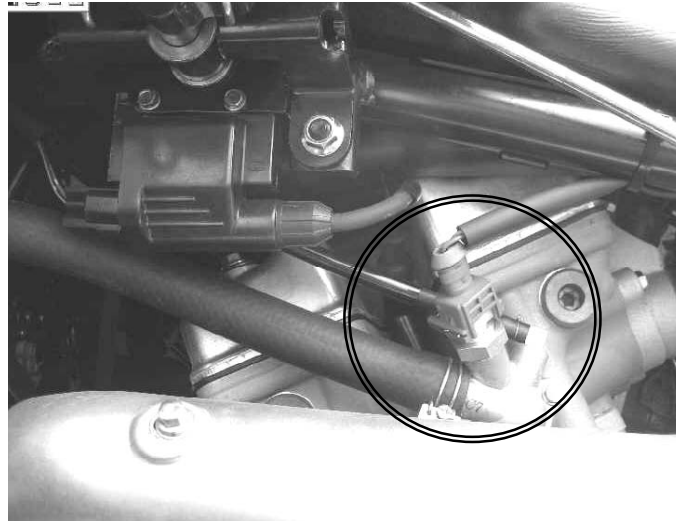

Install a new O-ring and WTS sensor.

* Always replace an O-ring with a new one.

Tighten the WTS sensor to the specified torque.

Torque: 1.2 kgf-m (12 N-m, 8.6 lbf-ft)

Connect the WTS sensor connector.

Fill the cooling system with the recommended coolant.

INSPECTION

Measure the resistance at the WTS sensor terminals.

STANDARD

°C	-20	40	100
KΩ	28.6	1.46	0.176

Standard: 3.51±10% KΩ (at 20°C/68°F)

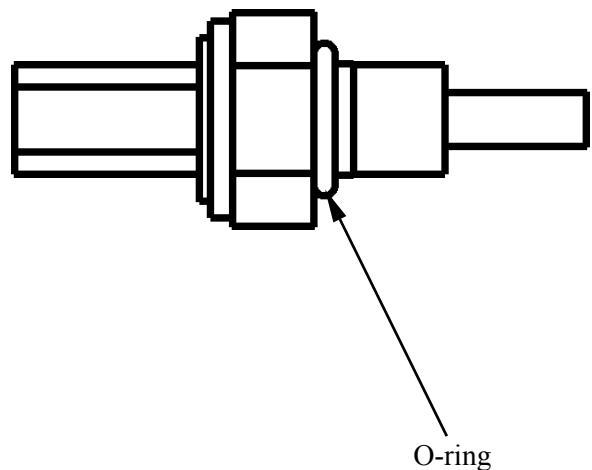

THROTTLE BODY

/T-MAP SENSOR/ISC/TPS

- Turn off the ignition switch while replacement.
- Check and confirm if the voltage is over 12V by a voltmeter after replacement.
- Check and confirm if the other connectors are installed correctly after replacement.
- Do not damage the throttle body, it may cause the throttle and idle valve isn't synchronization.
- The throttle body is preset in KYMCO factory, do not disassemble it by a wrong way.
- Do not loosen or tighten the painted bolts and screws for the throttle body. Loosen or tighten them can cause the throttle and idle valve to synchronization failure.
- **TPS and ISC have to be reset after the throttle body T-MAP, TPS, ISC or ECU has been reinstalled.**

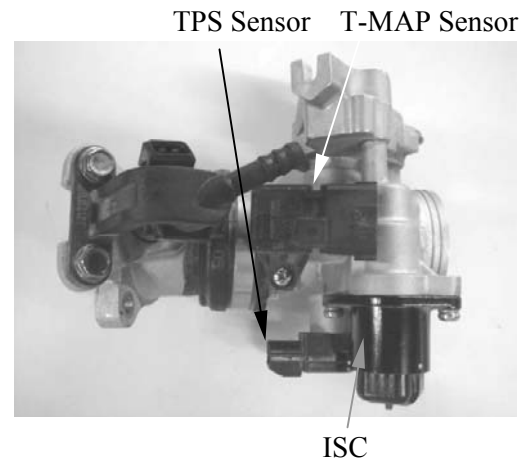

T-MAP SENSOR INSPECTION

Support the scooter on a level surface.

Put the side stand up and engine stop switch is at "RUN".

Turn the ignition switch to "ON" position.

Measure if the ECU voltage outputs to the T-MAP sensor between the following terminals of the MAP connector.

Terminal	Normal
V/R (+) -V/G (-)	5 V

5. FUEL INJECTION SYSTEM

TPS INSPECTION

Support the ATV on a level surface.

Turn the ignition switch to “ON”.

Measure if the ECU voltage outputs to TPS between the following terminals of the TPS connector.

Terminal	Normal
V/R (+) -V/G(-)	5 V

Throttle position sensor (TPS) resistance
(at 20°C/68°F) 3500~6500 Ω



REMOVAL

Loosen the throttle cables with the adjusting nuts.

Disconnect the throttle cable ends from throttle seat.

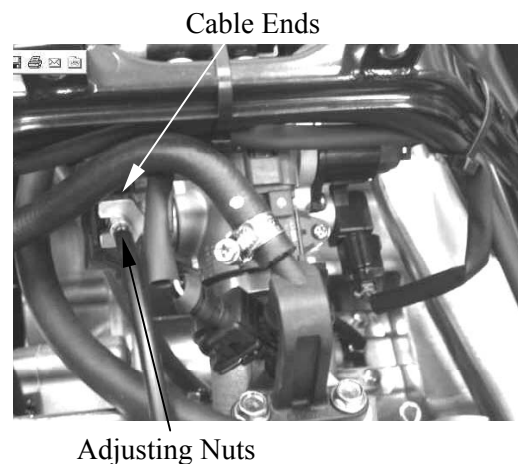

Disconnect the TPS, ISC and T- MAP sensor connectors.

Loosen the air cleaner connecting hose band screw.

Loosen the intake manifold band screw.

Remove the throttle body, T-MAP sensor, TPS sensor and ISC sensor as a set.

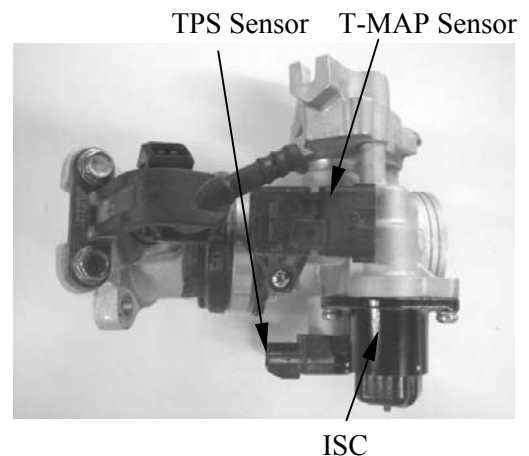

5. FUEL INJECTION SYSTEM

DISASSEMBLY

Remove the screws and then remove the ISC .

Remove the screw..

Remove the T-MAP sensor.

Remove the screw and then remove the TPS.

ASSEMBLY

*

The throttle position sensor (TPS) and idle air bypass valve (ISC) have to reset when the throttle body T-MAP sensor, TPS, ISC or ECU has been reinstalled.

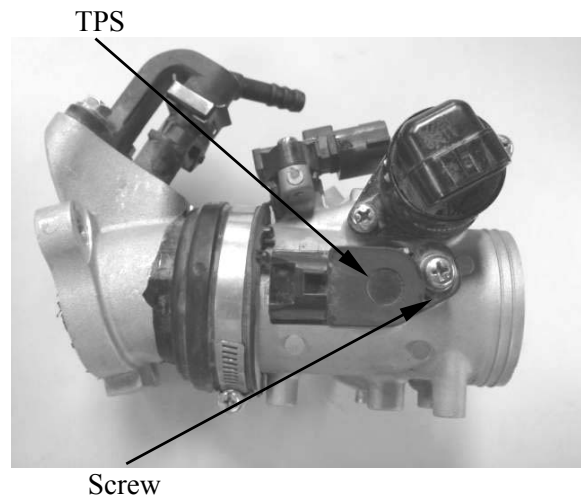
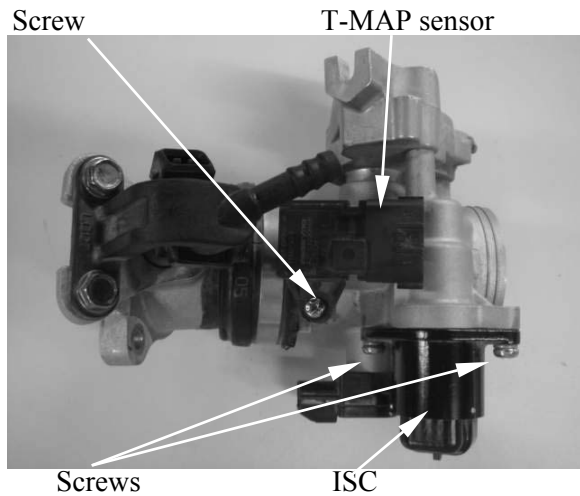

Apply oil onto a new O-ring.

When install the TPS onto the throttle body, being careful not to damage the O-ring. Install and tighten the screw securely.

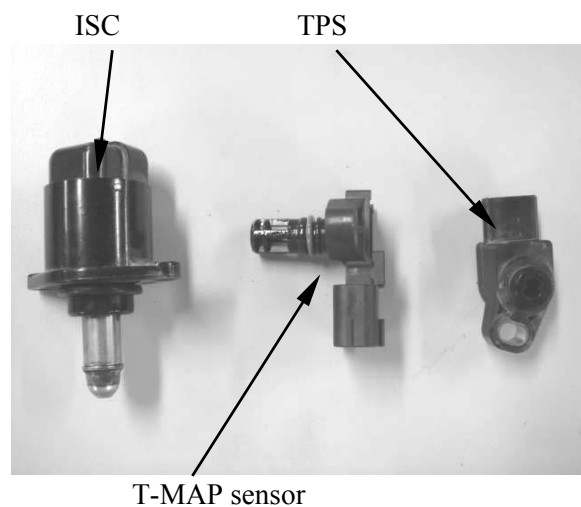

5. FUEL INJECTION SYSTEM

Apply oil onto a new O-ring.

When install the T-MAP sensor onto the throttle body, being careful not to damage the O-ring.

* Always replace an O-ring with a new one.

Install the set plate and tighten the screw securely.

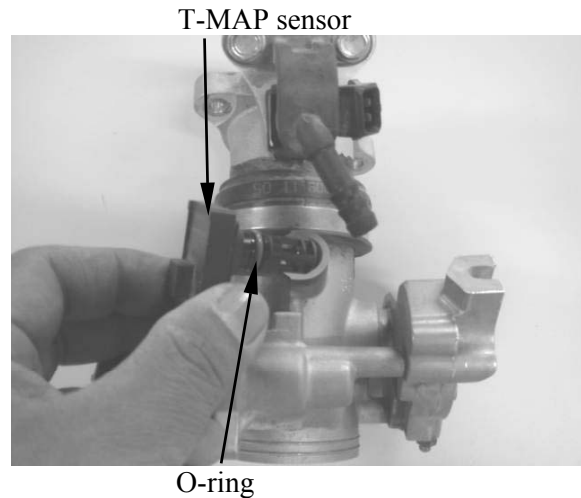

Apply oil onto a new O-ring.

When install the ISC and T-MAP sensor onto the throttle body, being careful not to damage the O-ring.

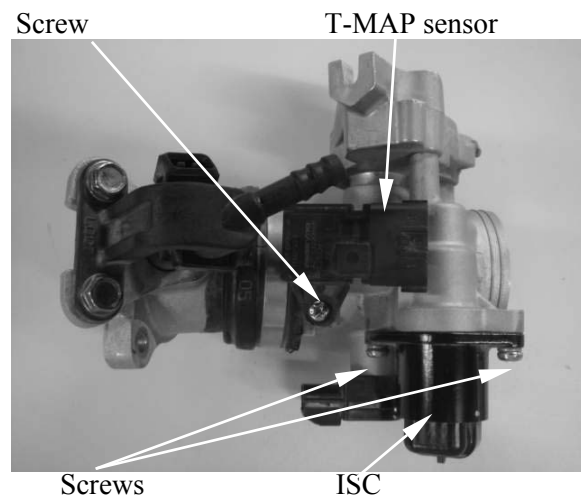

DIAGNOSTIC TOOL CONNECTOR

INSPECTION

Remove front cover

Make sure moving the shift lever into the N or P position .

Remove diagnostic tool connector protect sheath.

Turn the ignition switch to “ON”

Measure the voltage between the following terminals of the diagnostic tool connector .

Terminal	Normal
BR/L (+) G/B (-)	Battery voltage
B/L (+) W/L (-)	Battery voltage - 1 V

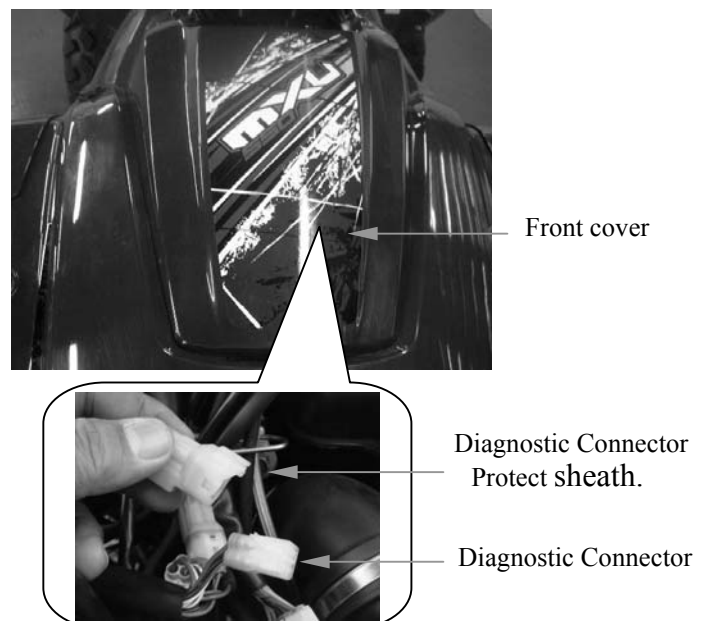

5. FUEL INJECTION SYSTEM

KYMCO Diagnostic Report MXU 550EXi

SF :
Production
Date :

Customer :
Service
Date :

Eng. No:
Mileage :

Reason of repair: maintenance breakdown

Item		Data	Reference	Memo
ECU Version	ECU No			
	Hardware Ver			
	Software Ver			
	Calibration Ver			
	Model Name			
DTC	Active			
	Occurred			
	History			
(Cool Engine) EngineStop	Engine Temp.(Coiling)		environ.temp ± 2 °C	
	Air Temp.(°C)		environ.temp ± 2 °C	
	Atom. Pressure(Kpa)		101.3 ± 3 kPa	The ambient pressure drop about 12 kpa at the altitude every 1000m raised
	Throttle Position(%)		0% / 56% below	
	Throttle Position (V)		(0.67V ± 0.05 / 2.1V)below	
	TPIIdleMean (V)		0.67±0.05	
	Battery Volt (V)		>12 V	
(Hot Engine) BeforeRepair	EngineSpeed IDLE(rpm)		1400 ± 100 rpm	
	Engine Temp. (°C)		>80 °C	
	Air Temp.(°C)		45 ~ 65 °C	
	MAPSample (kPa)		30 ~ 40 kpa	
	Injection duration (ms)		3.2 ~ 4.2 ms	
	Ign. Advance (°)		10 ~ 15 BTDC	
	ISC STEP(ABV)		< 65	
	IDLE CO(%)		1.0 ~ 5.0 %	
(Hot Engine) AfterRepair	EngineSpeed IDLE(rpm)		1400 ± 100 rpm	
	Engine Temp. (°C)		>80 °C	
	Air Temp.(°C)		45 ~ 85 °C	
	MAPSample (kPa)		30 ~ 40 kpa	
	Injection duration (ms)		3.2 ~ 4.2 ms	
	Ign. Advance (°)		10 ~ 15 BTDC	
	ISC STEP(ABV)		< 65	
	IDLE CO(%)		1.0 ~ 5.0 %	
Repair description		Repair Process		

Report ID=



ATV FI DIAGNOSTIC TOOL OPERATION INSTRUCTIONS 3620A-LEB2-E00(ENGLISH VERSION)

version:V1.0.7 or over

1. FI DIAGNOSTIC TOOL

- This tool is developed by KYMCO and for KYMCO vehicle only.
- Please refer to the specification when serving this vehicle.
- This tool is without battery inside. The power is provided from vehicle.
- This software can be updated with computer for new model through the USB cable. The power required of tool is connected with 12V battery.
- For connection, please connect this tool with the connector of ECU. It's available when turning on the ignition switch.

- The function includes ECU version, model name, data analysis .
 - ECU version: includes model name, ECU number, identifications number and software version.
 - Failure codes: DTC reading, DTC clearing and troubleshooting.
 - Data analysis: For ECU's software inspection.
 - Adjust : The adjust function setting is not allowed

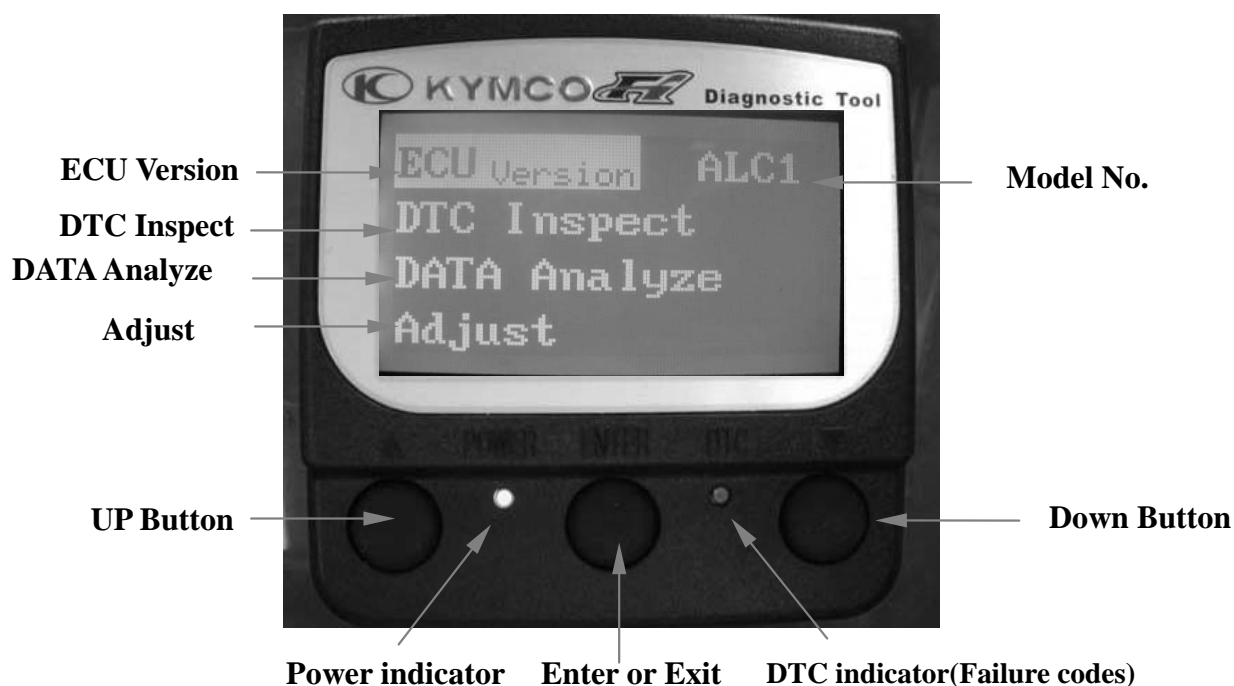

2. DTC INSPECTION PROCEDURE

Showing four functions on the screen when switching on power.



ALC1 is for
MXU550EXi
AAA5 is for
New MXU 500i

A). ECU version: Including of model name, ECU number, identifications number and software version. Press the **Enter** button

Press the " Enter " button



ALC1 is for
MXU550EXi
AAA5 is for
New MXU 500i

B). Press the " Down " button and then turn to the first page.



C). Press the " Enter " button to check the DTC failure code



D). Press the " Enter " button



E). Press the " Enter " button

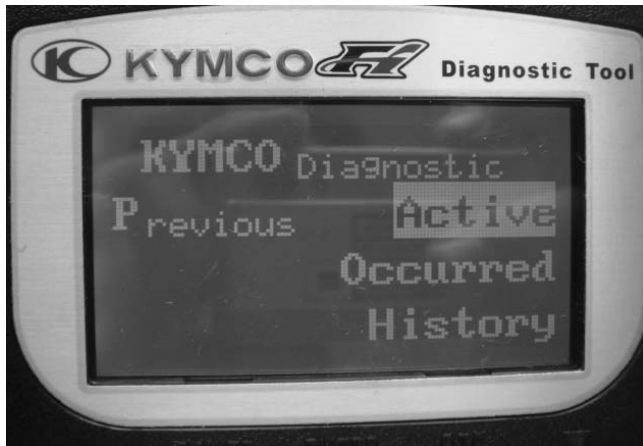

F). Display what's DTC number on this DTC-List.

Press the " Enter " button and then turn to the previous page



G). Press the " UP " button



H). Press the " Enter " button and then turn to the previous page .

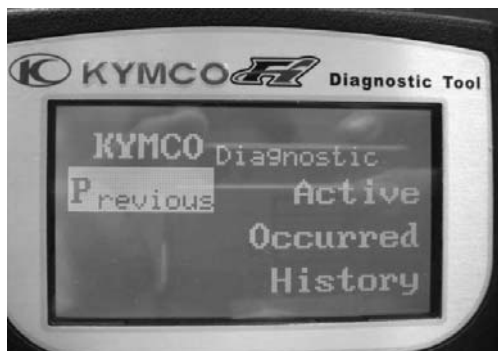

I). Press the " UP " button



J). Press the " Enter " button and then turn to the first page.



5. FUEL INJECTION SYSTEM

3. DTC CLEAR PROCEDURE

A). Check the DTC



B). Press the " Enter " button



C). Choose " Load DTC "
Press the " Down " button



D). Press the " Enter " button and the indicator is lighting.



E). Clearing DTC completed if the indicator is off.



5. FUEL INJECTION SYSTEM

4. DATA ANALYSIS PROCEDURE

A). Press the " Down " twice



B). Choose " Data Analyze"

Press the " Enter " button to enter page 01



C). Down-page 01

The measure figures including of Engine speed, Battery voltage and Engine speed.

Press the " Down " button to enter page 02.



D). Down-page 02

The measure figures including of TPS position, TPI idle adapted .

Press the “ Down” button to enter page 03.



Idle Position

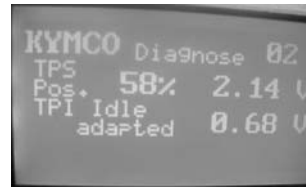

Wot position-on road



Wot position-off road

E). Down-page 03

The measure figures including of engine temperature ,air temperature and intake pressure .Press the “ Down” button to enter page 04.



F). Down-page 04

The measure figures including of atmospheric pressure, fuel injector interval and ignition advance . Press the “ Down” button to enter page 05.



5. FUEL INJECTION SYSTEM

G). Down-page 05

The measure figures including of rollover voltage.

- Press the " Down " button to enter page 06.



H). Down-page 06

The measure ISC step data.

- Press the " Down " button to enter page 07.



I). Down-page 07

The measure figures including of ECU counter.



- Press the " UP " to the previous page.

COOLING SYSTEM**6**

SYSTEM FLOW PATTERN-----	6- 1
SERVICE INFORMATION-----	6- 2
TROUBLESHOOTING-----	6- 4
COOLING SYSTEM TESTING-----	6- 5
COOLANT REPLACEMENT -----	6- 5
THERMOSTAT-----	6- 8
WATER PUMP -----	6-11
RADIATOR -----	6-14
FAN MOTOR SWITCH -----	6-15
FAN MOTOR -----	6-16
WATER TEMPERATURE SENSOR -----	6-17
RAIDATOR RESERVE TANK -----	6-18

6. COOLING SYSTEM

SYSTEM FLOW PATTERN

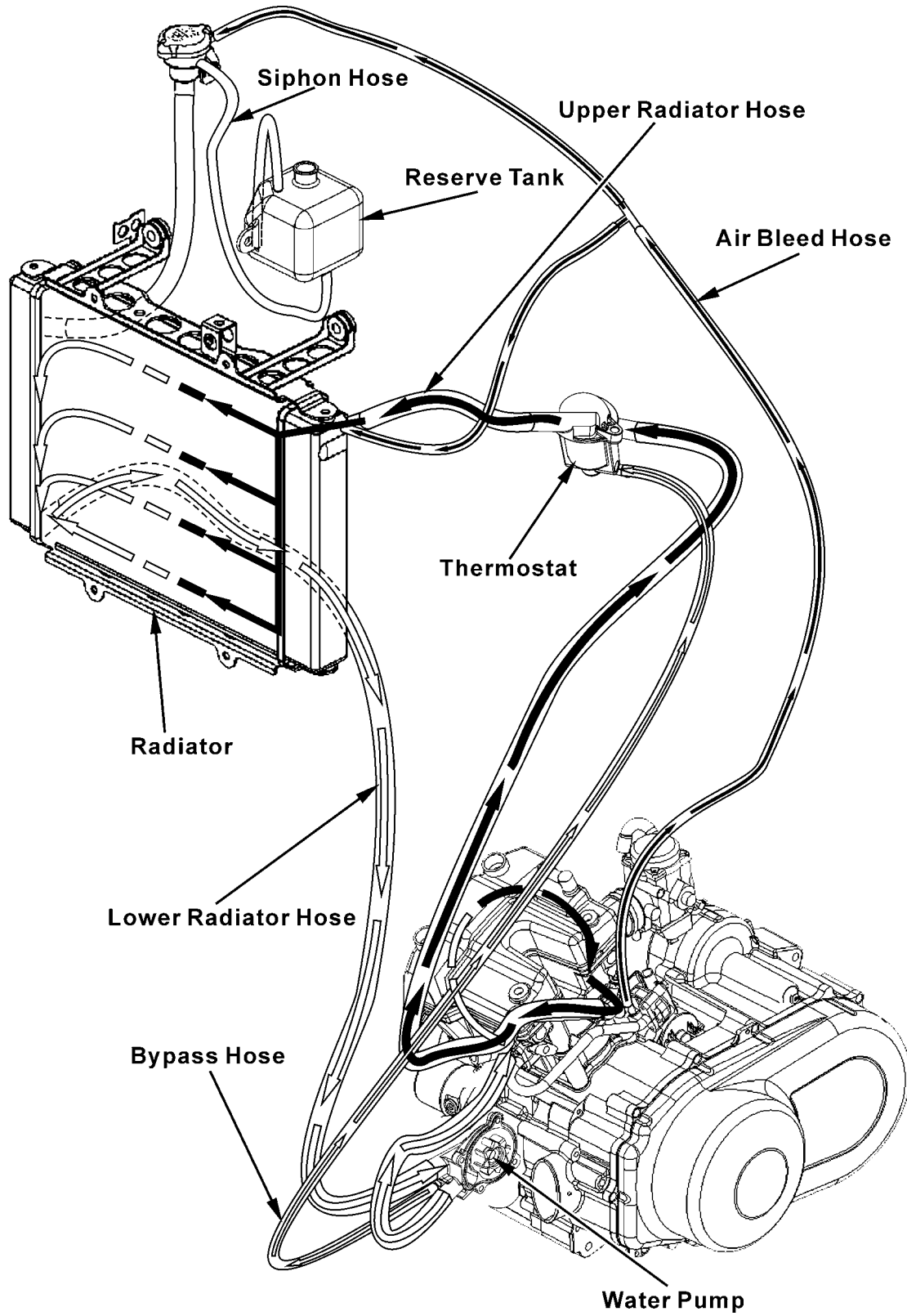

6. COOLING SYSTEM

MXU 550EXi/MXU500i

SERVICE INFORMATION

GENERAL INSTRUCTIONS

WARNING:

Removing the radiator cap while the engine is hot can allow the coolant to spray out, seriously scalding you. Always let the engine and radiator cool down before removing the radiator cap.

CAUTION:

Radiator coolant is toxic. Keep it away from eyes, mouth, skin and clothes.

- If any coolant gets in your eyes, rinse them with water and consult a physician immediately.
- If any coolant is swallowed, induce vomiting, gargle and consult a physician immediately.
- If any coolant gets on your skin or clothes, rinse thoroughly with plenty of water.

NOTE:

Use coolant with silicate inhibitors may cause premature wear of water pump seals or blockage of radiator passages. Using tap water may cause engine damage.

- This section covers service of the cooling system.
- Add coolant at the reserve tank. Do not remove the radiator cap except to refill or drain the system.
- All cooling system services can be done with the engine in the frame.
- Avoid spilling coolant on painted surfaces.
- After servicing the system, check for leaks with a cooling system tester.

SPECIFICATIONS

ITEM		SPECIFICATIONS
Coolant capacity	Radiator and engine	2 liter (2.1 US qt, 1.76 Imp qt)
	Reserve tank	0.45 liter (0.47 US qt, 0.39 Imp qt)
Radiator cap relief pressure		90 kPa (0.9 kgf/cm ² , 12.8 psi)
Thermostat	Begin to open	80 - 84°C (176 - 183°F)
	Fully open	95°C (203°F)
	Valve lift	8 mm (0.3 in) minimum
Standard coolant concentration		1:1 mixture with soft water

6. COOLING SYSTEM

MXU 550EXi/MXU500i

COOLANT GRAVITY CHART

Temp. °C Coolant concentration	0	5	10	15	20	25	30	35	40	45	50
5%	1.009	1.009	1.008	1.008	1.007	1.006	1.005	1.003	1.001	0.009	0.997
10%	1.018	1.107	1.017	1.016	1.015	1.014	0.013	1.011	1.009	1.007	1.005
15%	1.028	1.027	1.026	1.025	1.024	1.022	1.020	1.018	1.016	1.014	1.012
20%	1.036	1.035	1.034	1.033	1.031	1.029	1.027	1.025	1.023	1.021	1.019
25%	1.045	1.044	1.043	1.042	1.040	1.038	1.036	1.034	1.031	1.028	1.025
30%	1.053	1.051	1.051	1.049	1.047	1.045	1.043	1.041	1.038	1.035	1.032
35%	1.063	1.062	1.060	1.058	1.056	1.054	1.052	1.049	1.046	1.043	1.040
40%	1.072	1.070	1.068	1.066	1.064	1.062	1.059	1.056	1.053	1.050	1.047
45%	1.080	1.078	1.076	1.074	1.072	1.069	1.056	1.063	1.062	1.057	1.054
50%	1.086	1.084	1.082	1.080	1.077	1.074	1.071	1.068	1.065	1.062	1.059
55%	1.095	1.093	1.091	1.088	1.085	1.082	1.079	1.076	1.073	1.070	1.067
60%	1.100	1.098	1.095	1.092	1.089	1.086	1.083	1.080	1.077	1.074	1.071

COOLANT MIXTURE (WITH ANTI-RUST AND ANTI-FREEZING EFFECTS)

Freezing Point	Mixing Rate	KYMCO SIGMA Coolant Concentrate	Distilled Water
-9°C	20%		
-15°C	30%	425cc	975cc
-25°C	40%		
-37°C	50%		
-44.5°C	55%		

Cautions for Using Coolant:

- Use coolant of specified mixing rate. (The mixing rate of 425cc coolant concentrate + 975cc distilled water is 30%.)
- Do not mix coolant concentrate of different brands.
- Do not drink the coolant, which is poisonous.
- The freezing point of coolant mixture shall be 5°C lower than the freezing point of the riding area.

6. COOLING SYSTEM

TORQUE VALUES

Water pump cover bolt	1.3 kgf-m (13 N-m, 9 lbf-ft)
Fan motor bolt	0.53 kgf-m (5 N-m, 3.8 lbf-ft)
Fan motor switch	1.8 kgf-m (17 N-m, 13 lbf-ft)

TROUBLESHOOTING

Engine temperature too high

- Faulty radiator cap
- Faulty temperature gauge or thermosensor
- Air in system
- Thermostat stuck closed
- Insufficient coolant
- Passages blocked in radiator, hoses or water jacket
- Faulty cooling fan motor
- Faulty fan motor switch
- Faulty water pump

Engine temperature too low

- Faulty temperature gauge or thermosensor
- Thermostat stuck open
- Faulty fan motor switch

Coolant leak

- Faulty water pump mechanical seal
- Deteriorated O-rings
- Faulty radiator cap
- Damaged or deteriorated cylinder head gasket
- Loose hose connection or clamp
- Damaged or deteriorated hoses

6. COOLING SYSTEM

COOLING SYSTEM TESTING

RADIATOR CAP INSPECTION

Remove the radiator cap (refer to the “**COOLANT REPLACEMENT**” section in this chapter).

Pressure test the radiator cap.
 Replace the radiator cap if it does not hold pressure, or if relief pressure is too high or too low.
 It must hold the specified pressure for at least six seconds.

* Before installing the cap in the tester, wet the sealing surface.

Radiator Cap Relief Pressure:

90 kPa (0.9 kg/cm², 12.8 psi)

Pressurize the radiator, engine and hoses, and check for leaks.

* Excessive pressure can damage the cooling system components.
 Do not exceed 105 kPa (1.05 kg/cm², 14.9 psi).

Repair or replace components if the system will not hold the specified pressure for at least six seconds.

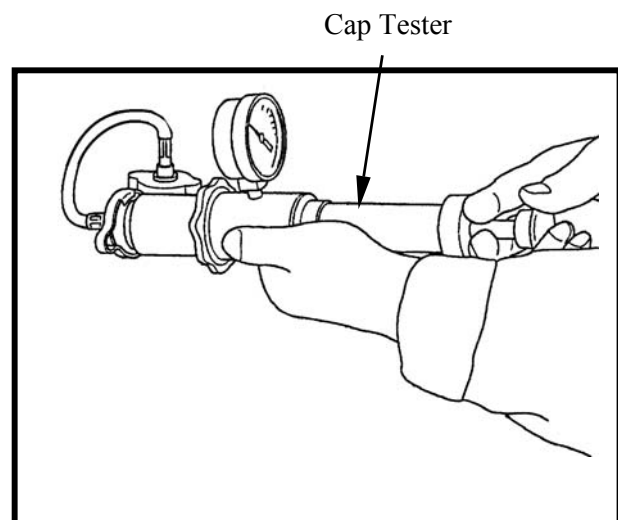
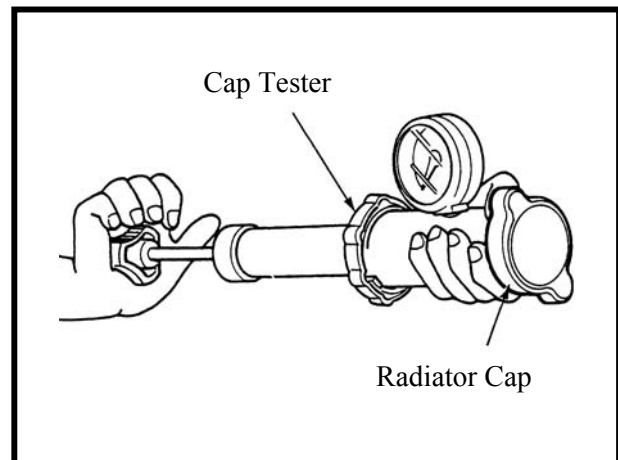

COOLANT REPLACEMENT

PREPARATION

- The effectiveness of coolant decreases with the accumulation of rust or if there is a change in the mixing proportion during usage. Therefore, for best performance change the coolant regularly as specified in the maintenance schedule.
- Mix only distilled, low mineral water with the antifreeze.

Recommended mixture:

1:1 (Distilled water and antifreeze)

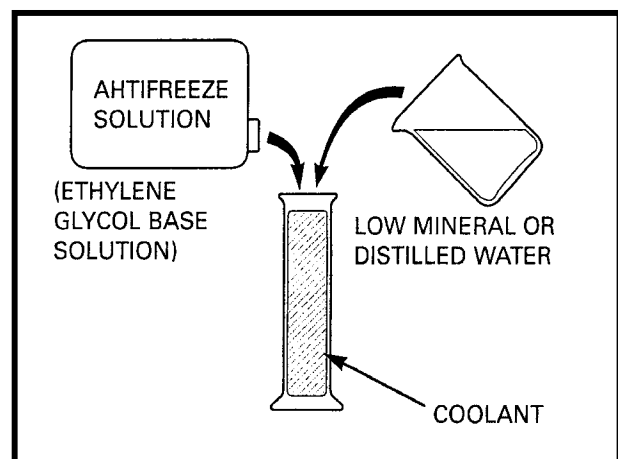

6. COOLING SYSTEM

REPLACEMENT/AIR BLEEDING

Remove the front center cover and right footboard (refer to the “**FRAME COVERS**” section in the chapter 2).

* When filling the system or reserve tank with coolant (checking the coolant level), place the machine in a vertical position on a flat, level surface.

Remove the radiator cap.

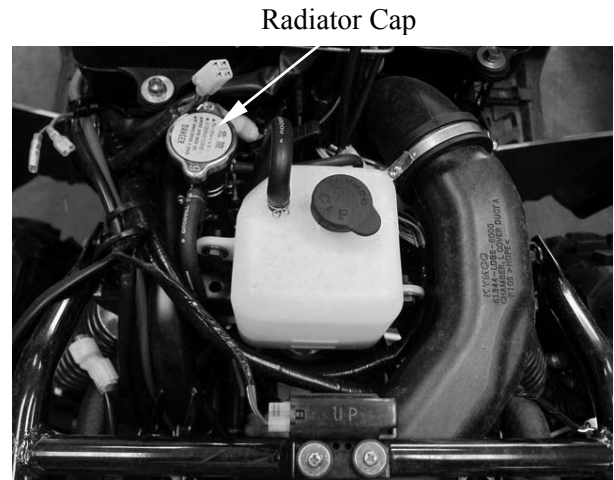

Loosen the hose band

Disconnect the bypass hose from water pump or remove the drain plug and drain the coolant from the system.

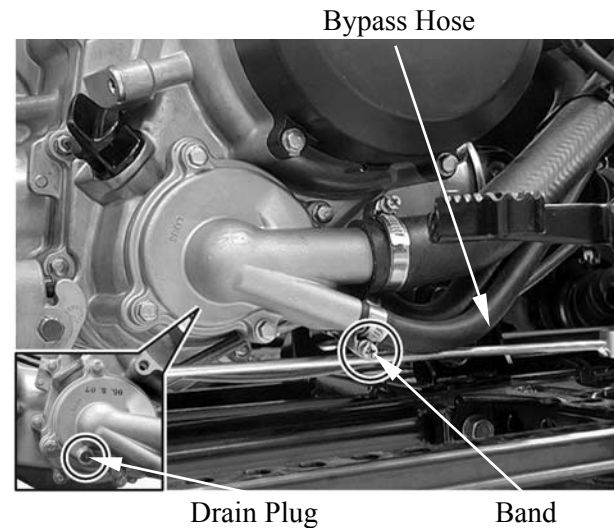

Remove the reserve tank cap and drain the coolant from the reserve tank.

Reconnect the bypass hose securely.



6. COOLING SYSTEM

Place the machine on a flat, level surface.
Fill the reserve tank to the upper level (FULL) line.

Reserve Tank Cap

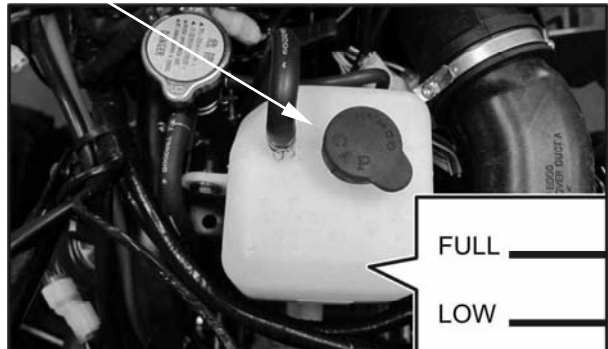

Fill the system with the recommended coolant through the filler opening up to the filler neck.

Filler Neck



Bleed air from the system as follow:

1. Start the engine and let it idle for 2–3 minutes.
2. Snap the throttle three to four times to bleed air from the system.
3. Stop the engine and add coolant to the proper level if necessary. Reinstall the radiator cap.
4. Check the level of coolant in the reserve tank and fill to the upper level if it is low.

6. COOLING SYSTEM

MXU 550EXi/MXU500i

THERMOSTAT

REMOVAL

Remove the nut and thermostat housing stay from the frame.

Remove the bolts, housing stay and thermostat housing cover.

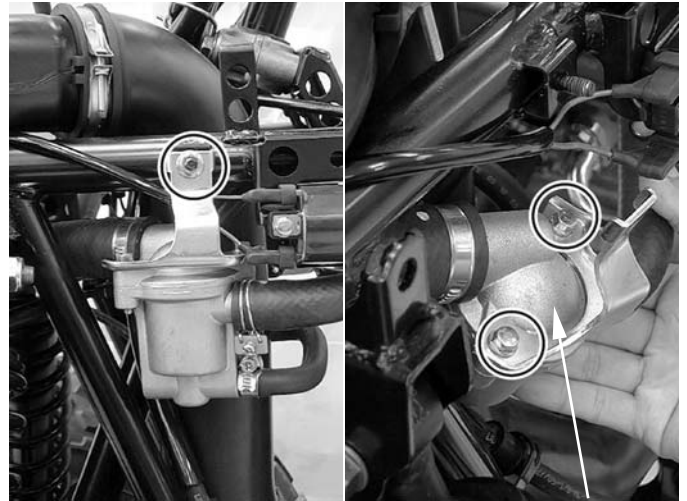

Housing stay

Thermostat Housing Cover

Remove the O-ring from the housing cover.
Remove the thermostat.



O-ring

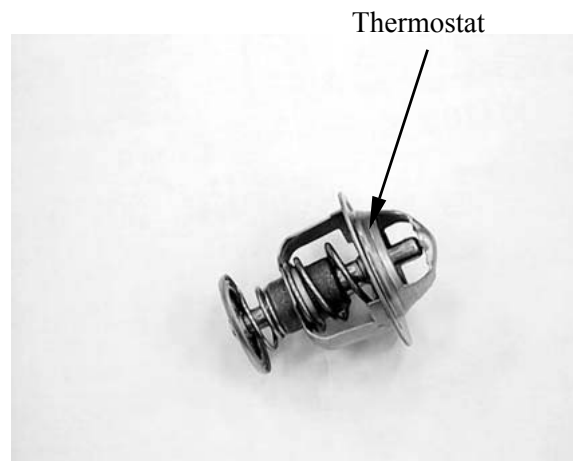

6. COOLING SYSTEM

INSPECTION

Visually inspect the thermostat for damage.

Heat the water with an electric heating element to operating temperature for five minutes.

Suspend the thermostat in heated water to check its operation.

- *

<ul style="list-style-type: none">• Keep flammable materials away from the electric heating element.• Do not let the thermostat or thermometer touch the pan, or you will get false readings.
--

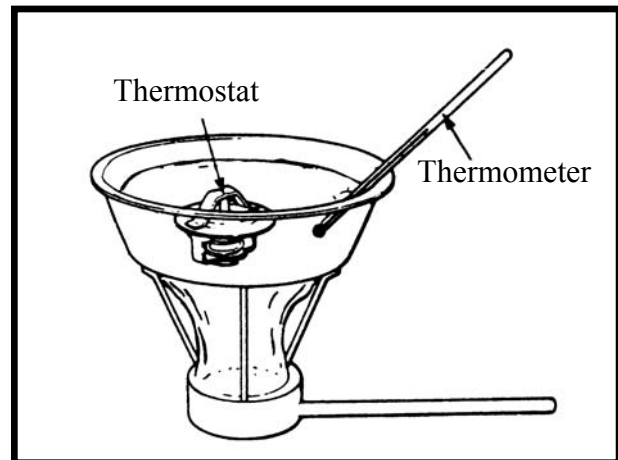

Replace the thermostat if the valve stays open at room temperature, or if it respond at temperatures other than those specified.

Thermostat begin to open:
80–84°C (176–183°F)

Valve lift:
8 mm (0.3 in) minimum at 95°C (203°F)

INSTALLATION

Install the thermostat into the housing with its air bleed hole facing up and aligning bleed hole with the tab in the housing.

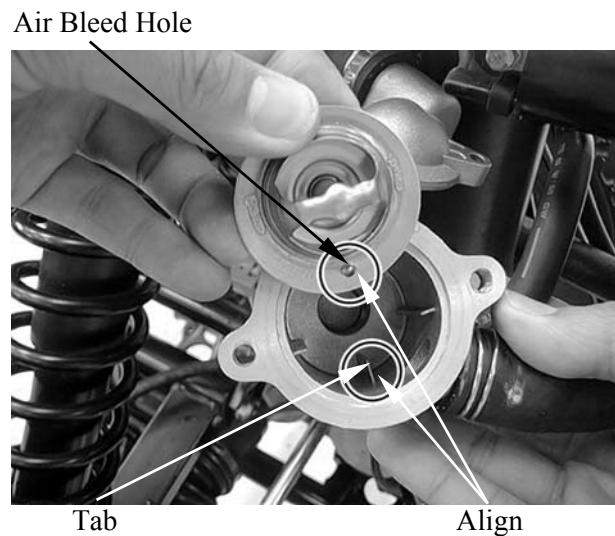

6. COOLING SYSTEM

Install a new O-ring into the housing cover groove.

Install the housing cover and housing stay to the housing.
Tighten the bolts securely.

Install the housing stay to the frame.
Tighten the nut securely.

Fill the system with recommended coolant and bleed the air (refer to the “**COOLANT REPLACEMENT**” section in this chapter).



6. COOLING SYSTEM

WATER PUMP

MECHANICAL SEAL INSPECTION

Inspect the coolant leakage.

If there is leakage, the mechanical seal is defective, and water pump body should be replaced.

REMOVAL

Drain the coolant (refer to the “**COOLANT REPLACEMENT**” section in this chapter).

Loosen the hose bands and disconnect the lower radiator hoses and bypass hose from the water pump.

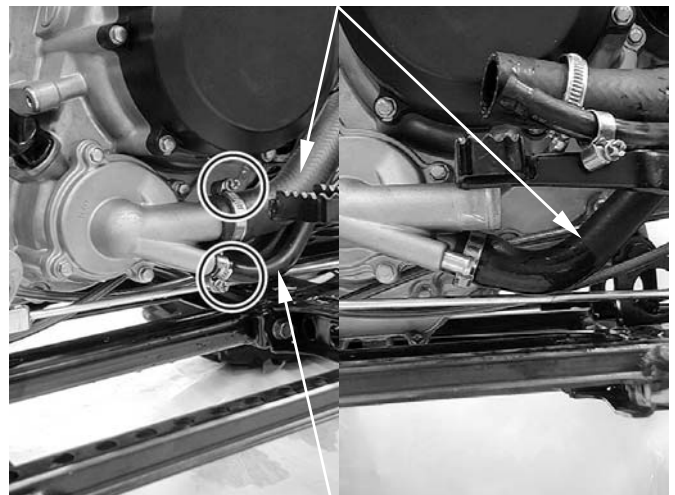

Bypass Hose

Remove the four bolts and water pump cover and O-ring.

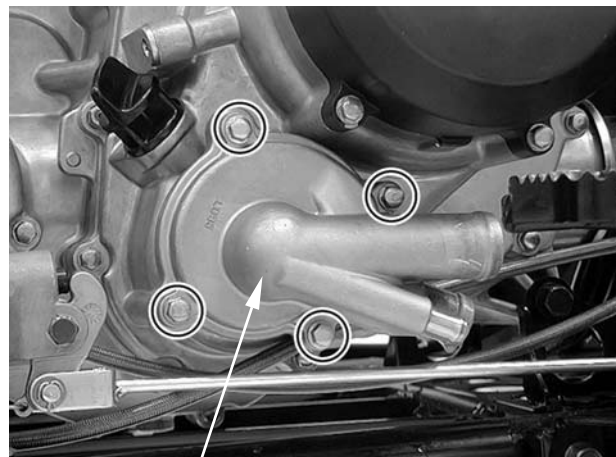

Water Pump Cover/O-ring

6. COOLING SYSTEM

MXU 550EXi/MXU500i

Remove the water pump body from the crankcase.

Water Pump Body

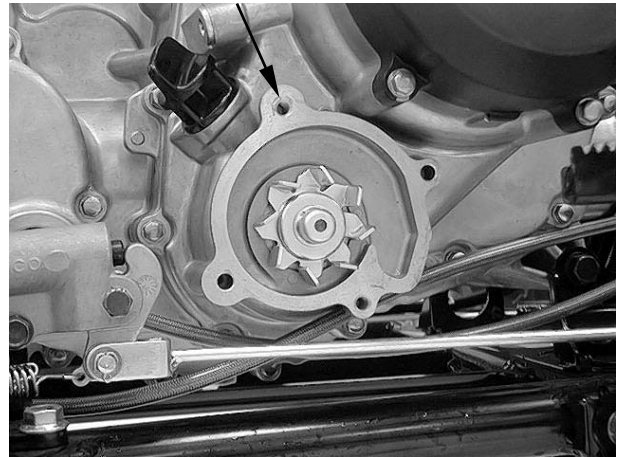

INSTALLATION

Apply engine oil to a new O-ring and install it onto the stepped portion of the water pump.

Install the water pump into the crankcase while aligning the water pump shaft groove with oil pump shaft end.

Align

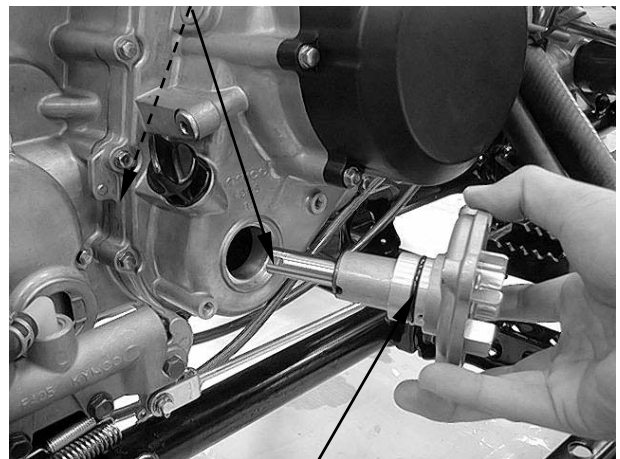

O-ring

Align the mounting bolt holes in the water pump and crankcase and make sure the water pump is securely installed.

Install a new O-ring into the groove in the water pump cover.

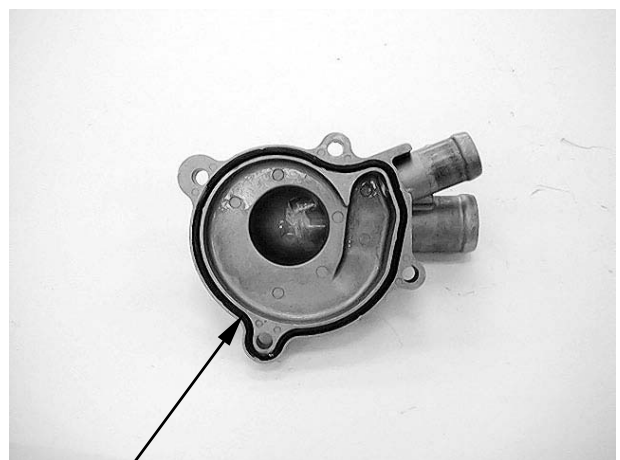

O-ring

6. COOLING SYSTEM

Install the water pump cover and tighten the bolts to the specified torque.

Torque: 1.3 kgf-m (13 N-m, 9 lbf-ft)

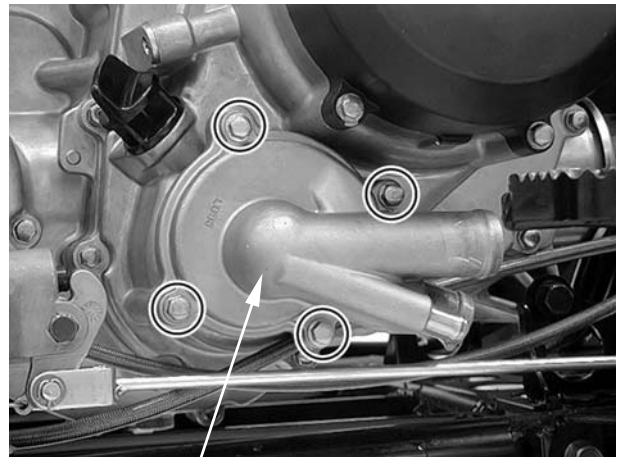

Water Pump Cover/O-ring

Connect the water hoses and bypass hose, then tighten the hose bands.

Fill the system with recommended coolant and bleed the air (refer to the “**COOLANT REPLACEMENT**” section in this chapter).

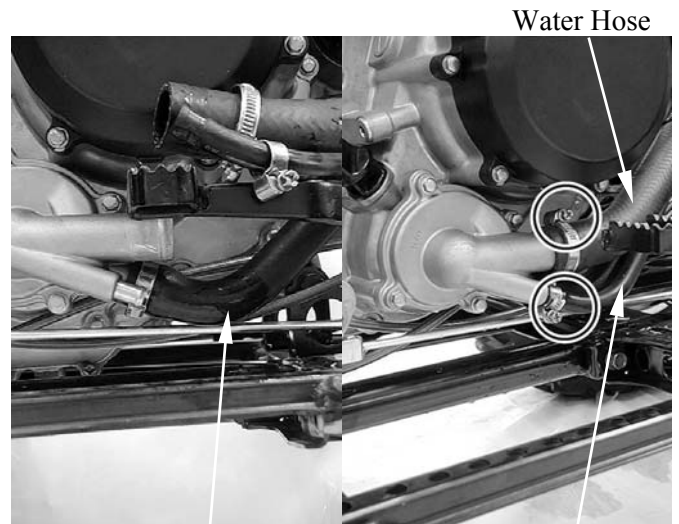

Water Hose

Bypass Hose

6. COOLING SYSTEM

RADIATOR

REMOVAL

Drain the coolant (refer to the “**COOLANT REPLACEMENT**” section in this chapter).

Remove the front fender (refer to the “**FRAME COVERS**” section in the chapter 2).

Remove the four mounting bolt from fan guide and then remove fan guide.

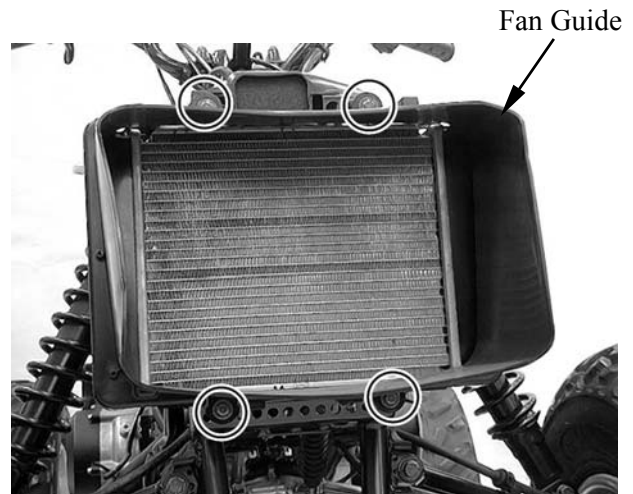

Loosen the hose bands and disconnect the radiator lower water hose, water filler hose, bleed hose and upper water hose from the radiator.

Disconnect the fan switch connectors.

Water Filler Hose

Upper Water Hose

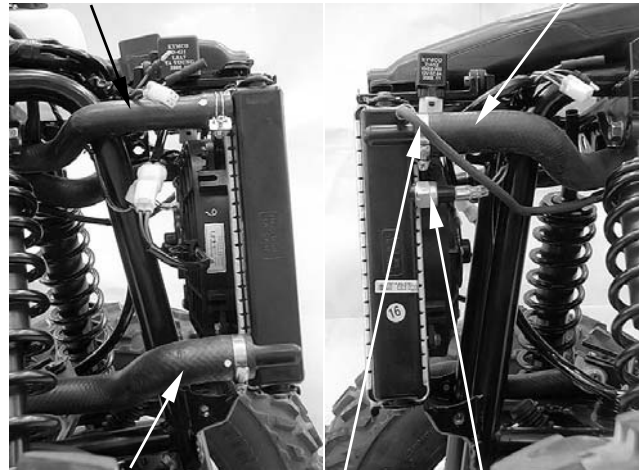

Lower Water Hose

Bleed Hose

Fan Motor SW

Remove the two mounting bolts under radiator and two mounting bolts on the radiator, then remove radiator.

* Be careful not to damage the radiator core.

INSTALLATION

Installation is in the reverse order of removal.

Fill the system with recommended coolant and bleed the air (refer to the “**COOLANT REPLACEMENT**” section in this chapter).

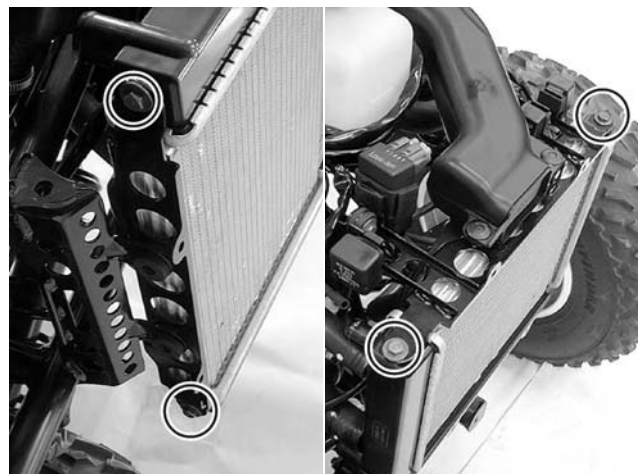

6. COOLING SYSTEM

FAN MOTOR SWITCH

REMOVAL

Disconnect the fan motor switch connectors (refer to the “**RADIATOR**” section in this chapter).

Remove the fan motor switch.

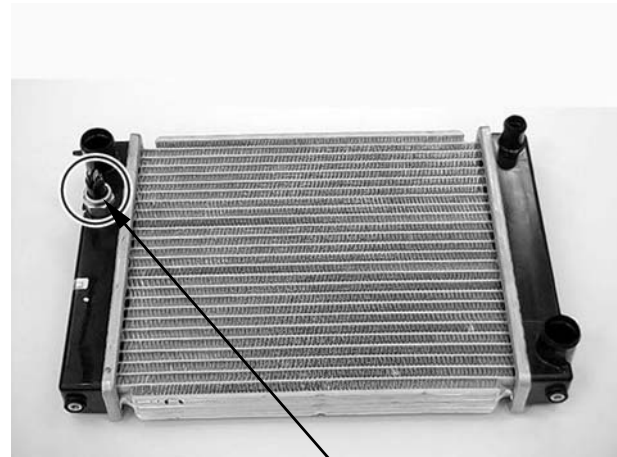

Fan Motor Switch

INSPECTION

Place the fan motor switch in oil contained in a pan as shown and raise the oil temperature gradually to check for the temperature at which the switch starts to operate.

If the switch operating temperature is not within the specified range, replace the switch with a new one.

OFF→ON	Over 88–92°C
ON→OFF	Lower 88–92°C

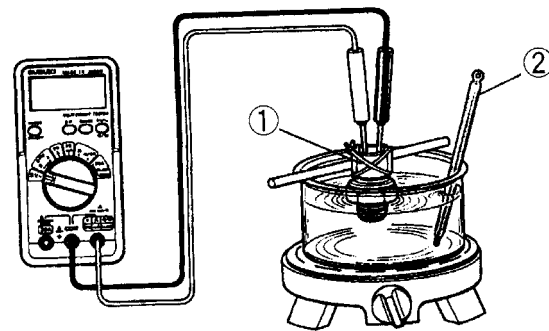

- * Handle the cooling fan motor switch carefully as it is vulnerable to impact.
- Do not allow the cooling fan motor switch \in and the thermometer \notin to come in contact with the bottom of the pan.

INSTALLATION

Fit the O-ring.

Tighten the cooling fan motor switch to specified torque.

Torque: 1.8 kgf-m (17 N-m, 13 lbf-ft)

- * Replace the O-ring a new one.
- Do not coat grease to the O-ring.

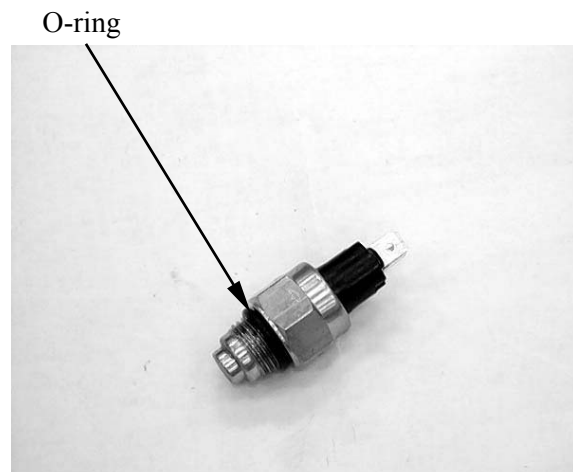

6. COOLING SYSTEM

FAN MOTOR

REMOVAL

Remove the front fender (refer to the “**FRAME COVERS**” section in the chapter 2)

Disconnect the fan motor connector.
Remove the four mounting bolts and then remove the fan motor

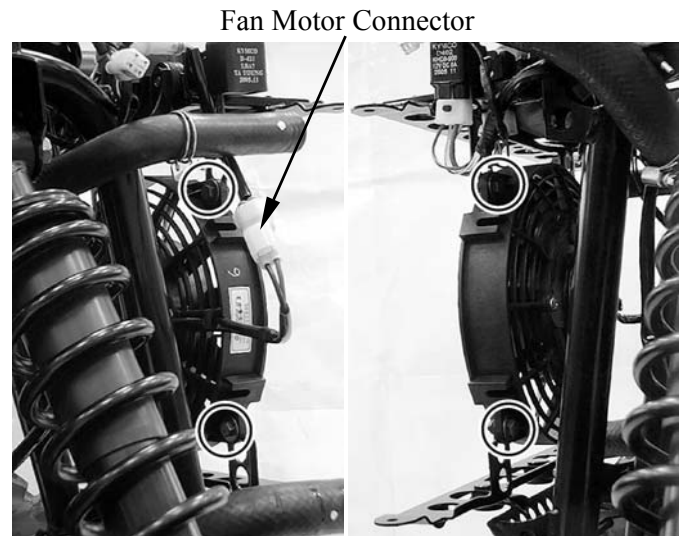

INSPECTION

Check the fan motor to operate using an available battery.

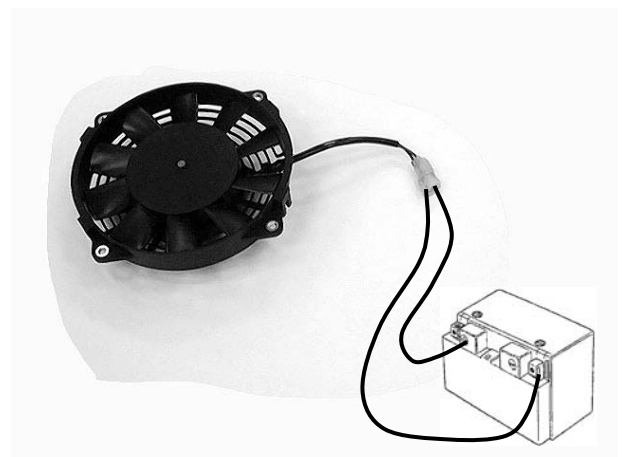

INSTALLATION

Installation is in the reverse order of removal.

6. COOLING SYSTEM

WATER TEMPERATURE SENSOR

Remove the right side body cover and right footboard (refer to the “**FRAME COVERS**” section in the chapter 2).

Disconnect the water temperature sensor connector.

Remove the water temperature sensor from the water joint.

Water Temperature Sensor

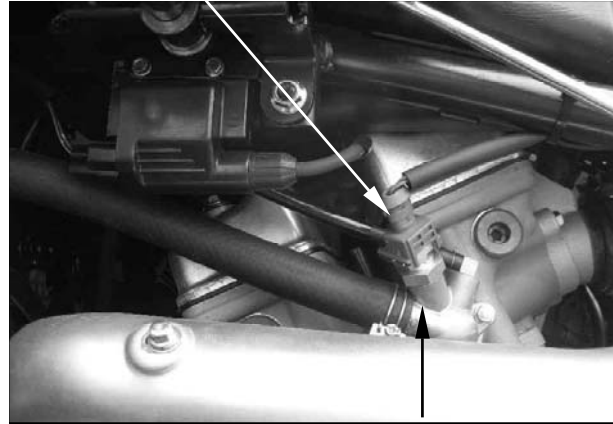

Water joint

INSPECTION

Connect the water temperature sensor to the ohmmeter. Attached the standard resistance list as bellow then check it.

Temperature	Standard resistance
-20°C/-4°F	28.6KΩ
40°C/104°F	1.46K Ω
20°C/68°F	3.51 KΩ±10%
100°C/212°F	0.176 KΩ

After the water temperature sensor has been installed, fill coolant and perform air bleeding (refer to the “**COOLANT REPLACEMENT**” section in this chapter).

INSTALLATION

With thread lock applied to the threaded part, tighten the water temperature sensor.

Torque: 0.8 kgf-m (8 N-m, 5.8 lbf-ft)

6. COOLING SYSTEM

RADIATOR RESERVE TANK

REMOVAL

Remove the front fender (refer to the “**FRAME COVERS**” section in the chapter 2).

Remove the two mounting bolts and then remove the radiator reserve tank from frame.

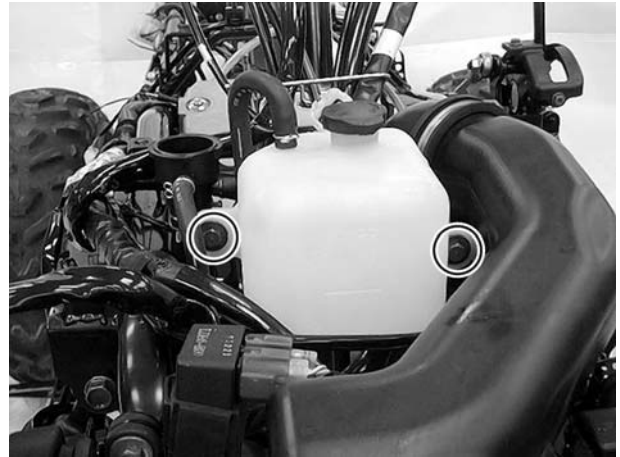

Open the reserve tank's cap and drain the coolant from the reserve tank.

Disconnect the siphon hose.

INSTALLATION

Installation is in the reverse order of removal.

Pour the recommended coolant to the upper level line with the center stand applied



Siphon Hose

7. ENGINE REMOVAL/INSTALLATION

ENGINE REMOVAL

SERVICE INFORMATION-----	7- 1
ENGINE REMOVAL -----	7- 2
ENGINE INSTALLATION -----	7- 8



7. ENGINE REMOVAL/INSTALLATION

SERVICE INFORMATION

GENERAL INSTRUCTIONS

- A floor jack or other adjustable support is required to support and maneuver the engine.
Be careful not to damage the machine body, cables and wires during engine removal.
- Use shop towels to protect the machine body during engine removal.
- The following components require engine removal for serviced with the engine installed in the frame.

Oil pump (Chapter 4)

Water pump (Chapter 6)

Cylinder head (Chapter 8)

Cylinder/Piston (Chapter 9)

Drive and driven pulleys/clutch (Chapter 10)

Alternator/Starter clutch (Chapter 17 and 19)

- The following components require engine removal for service.

Transmission (Chapter 11)

Crankshaft/Crankcase/Balance shaft (Chapter 12)

TORQUE VALUES

Engine mounting bolt/nut

6 kgf-m (60 N-m, 43.5 lbf-ft)

Engine hanger nut

3.5 kgf-m (35 N-m, 25 lbf-ft)

7. ENGINE REMOVAL/INSTALLATION

ENGINE REMOVAL

Drain engine oil (refer to the “ENGINE OIL” section in the chapter 3).

Remove frame covers and exhaust pipe (refer to the “FRAME COVERS” section in the chapter 2).

Drain the engine coolant (refer to the “COOLANT REPLACEMENT” section in this chapter).

Remove the air cleaner housing and throttle body (refer to sections in the chapter 5).

Disconnect the lower water hose and bypass hose from water pump cover.

Cut the rubber band off on the water hose.

Loosen the band screw and remove the two mounting bolts from the rear cooling duct, then remove the rear cooling duct.

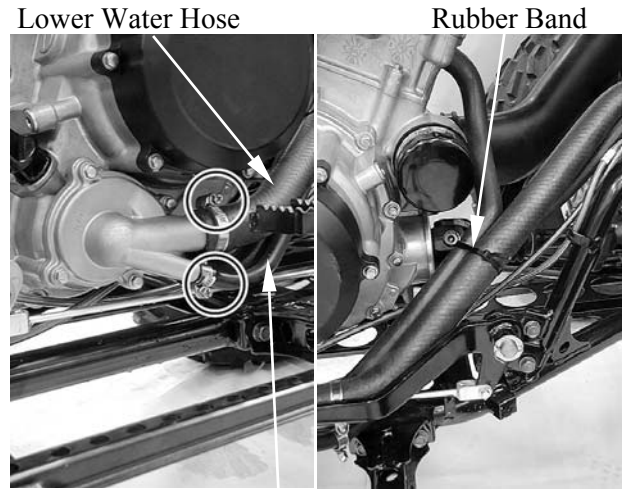

Bypass Hose

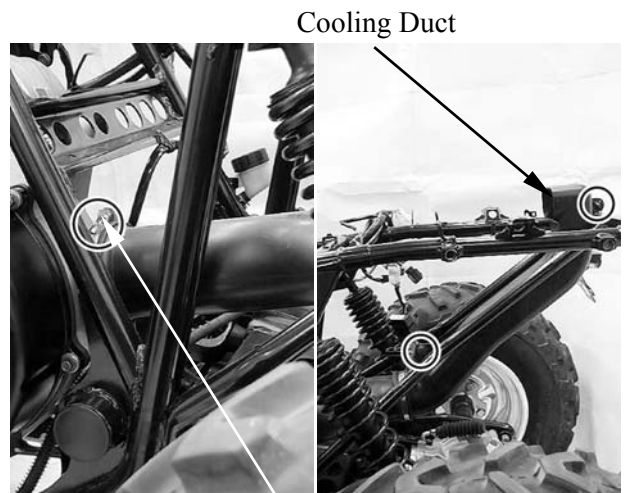

Band Screw

Loosen the band screw and remove the fastener from the front cooling duct, then remove the front cooling duct.

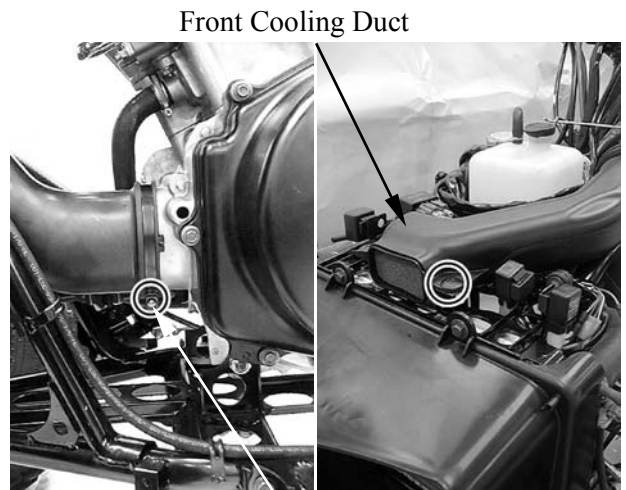

Band Screw

7. ENGINE REMOVAL/INSTALLATION

Disconnect the water hose, bleed hose and water temperature sensor connectors from water joint.

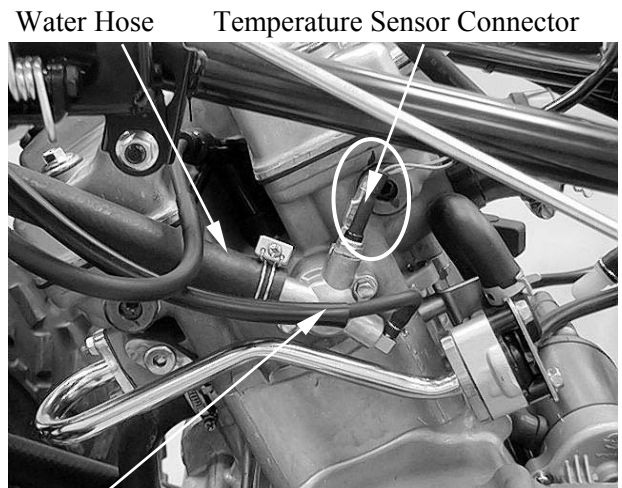

Bleed Hose

Remove the spark plug cap and disconnect the AICV air supply hose from cylinder head.



AICV Air Supply Hose

Remove the bolt/nut from drive select rod. Remove the mounting nuts from the drive select lever guide, then remove the guide and rod.



7. ENGINE REMOVAL/INSTALLATION

Disconnect the breather hose from cylinder head cover and remove the mounting nut from breather housing holder, then remove the breather housing.

Breather Hose



Disconnect the vacuum hose from intake pipe.

Slide the rubber sleeve back to expose the starter motor wire nut.

Remove the starter motor cable nut for disconnect the starter motor cable.

Remove the bolt and then disconnect the engine ground cable from starter motor.

Vacuum Hose

Starter Cable



Rubber Sleeve

Engine Ground Cable

Remove the A.C. Generator and ignition pulse generator connectors.

Ignition Pulse Generator



A.C. Generator Connector

7. ENGINE REMOVAL/INSTALLATION

Disconnect the gear indicator light switch connector.



Gear Indicator Light Switch Connector

Disconnect the speed sensor connector.

Speed Sensor Connector

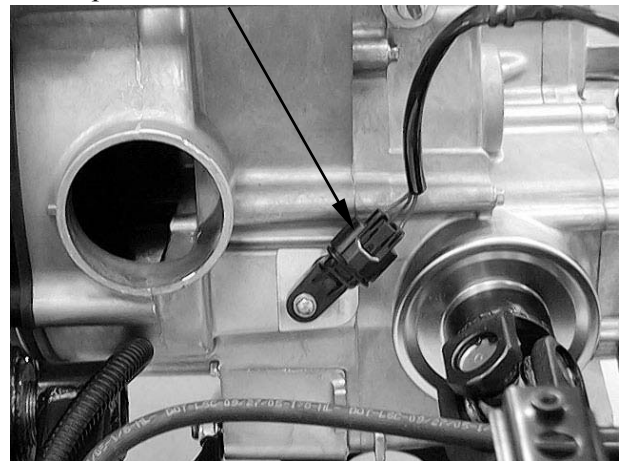

Remove the bolts and then remove the front propeller shaft from the engine assembly.

7. ENGINE REMOVAL/INSTALLATION

Remove the front lower engine mounting bolt/nut.

Remove the four nuts under right and left engine hangers, then remove the engine hangers.

Remove the rear lower engine mounting bolt/nut.

Lower Engine Mounting Bolt/Nut

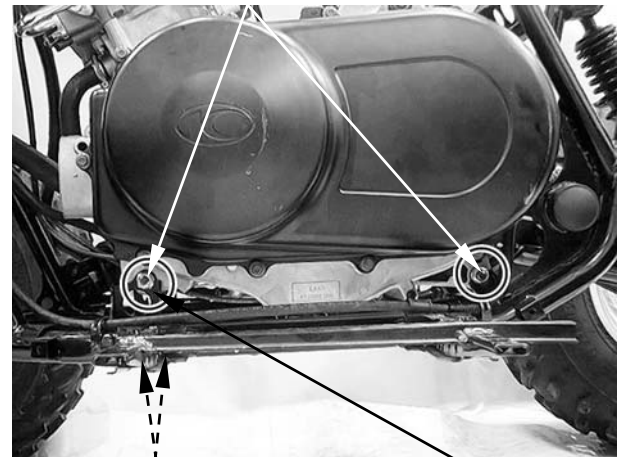

Engine Hanger Nuts

Engine Hanger

Remove the upper engine mounting bolt/nut.



Rise the engine front side and move the engine forward, then remove the engine from the frame by disengaging the rear drive gear case.

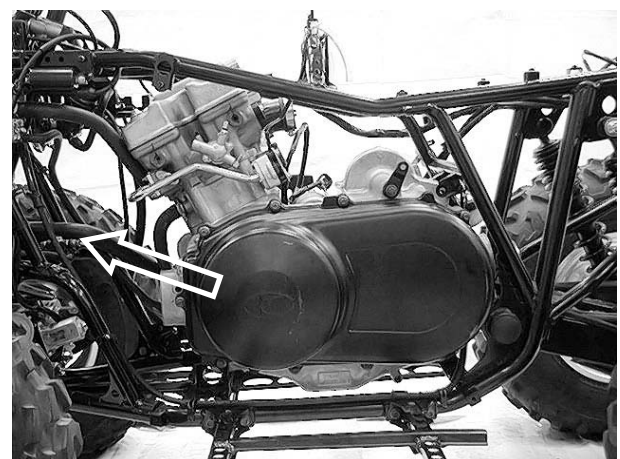

7. ENGINE REMOVAL/INSTALLATION

Tap the rear propeller shaft with rubber hammer and remove the rear propeller shaft from the engine assembly.

* Take care not to lose the compression spring in the rear drive gear case end.

Lower the cylinder head and rise the engine rear side, then move the engine from the frame left side.

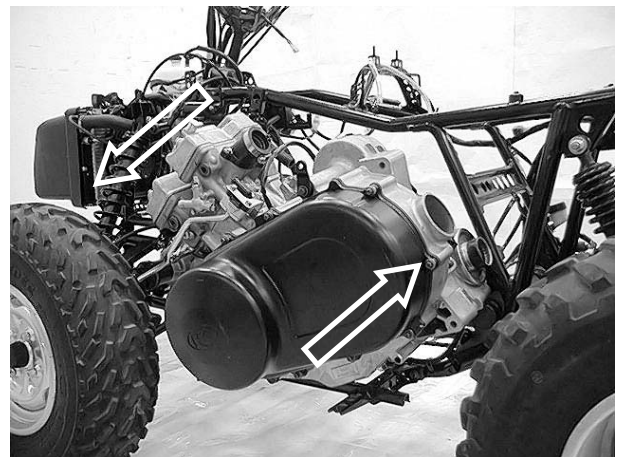

7. ENGINE REMOVAL/INSTALLATION

ENGINE INSTALLATION

Install the engine assembly into the frame.

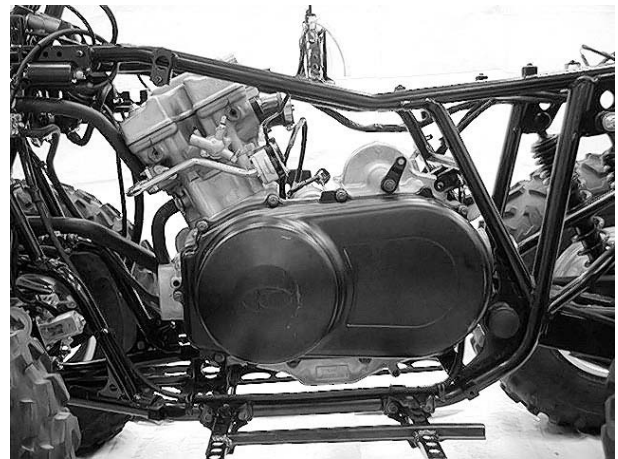

Apply lightweight lithium-soap base grease to the rear propeller shaft splines.

Install the rear propeller shaft into the engine assembly.

*

Apply lightweight lithium-soap base grease to the rear output shaft splines.
--

7. ENGINE REMOVAL/INSTALLATION

Install the compression spring into the pinion gear.

* Apply lightweight lithium-soap base grease to the pinion gear splines.

Move the engine rearward and engage the rear propeller shaft into the pinion gear.

* Install the joint boot securely.

Install the upper engine mounting bolt and nut loosely.



Lower Engine Mounting Bolt/Nut

Install the rear lower engine mounting bolt and nut loosely.

Install the engine hangers and four engine hanger nuts loosely.

Install the front lower engine mounting bolt and nut loosely.

Tighten the four engine hanger nuts to the specified torque.

Torque: 3.5 kgf-m (35 N-m, 25 lbf-ft)

Tighten the all engine mounting bolts and nuts to the specified torque.

Torque: 6 kgf-m (60 N-m, 43.5 lbf-ft)

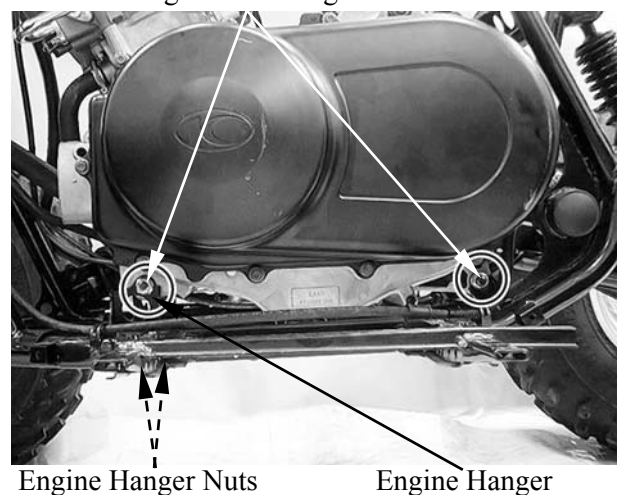

Engine Hanger Nuts

Engine Hanger

7. ENGINE REMOVAL/INSTALLATION

Apply lightweight lithium-soap base grease to the front propeller shaft splines and front output splines.

Install the front propeller shaft into the engine assembly.

* Always install the bolts with the new ones.

Install the front cooling duct.

* Make sure the lug on the left crankshaft case into the cutout on the front cooling duct.



7. ENGINE REMOVAL/INSTALLATION

Install the rear cooling duct.

- * Make sure the lug on the left crankshaft case into the cutout on the rear cooling duct.

Install the removed parts in the reverse order of removal.

Route the water hoses, wire and cable properly (refer to the “**CABLE & HARNESS ROUTING**” section in the chapter 1).

Adjusting the following items:

- Engine oil (refer to the “**ENGINE OIL**” section in the chapter 3).
- Engine coolant (refer to the “**COOLANT REPLACEMENT**” section in this chapter).



8. CYLINDER HEAD/VALVES

CYLINDER HEAD/VALVES

SCHEMATIC DRAWING -----	8- 1
SERVICE INFORMATION-----	8- 2
TROUBLESHOOTING-----	8- 3
CYLINDER COMPRESSION TEST -----	8- 4
CYLINDER HEAD COVER REMOVAL/INSTALLATION-----	8- 5
CYLINDER HEAD COVER DISASSEMBLY/ASSEMBLY-----	8- 6
CAMSHAFT REMOVAL/INSPECTION/INSTALLATION -----	8- 7
ROCKER ARMS REMOVAL/INSPECTION/INSTALLATION ----	8-15
CYLINDER HEAD REMOVAL/INSTALLATION-----	8-17
CYLINDER HEAD DISASSEMBLY/INSPECTION/ASSEMBLY -	8-24
CAM CHAIN REMOVAL/INSPECTION/INSTALLATION -----	8-28

8. CYLINDER HEAD/VALVES

SCHEMATIC DRAWING

LEA0AE(FR) E02

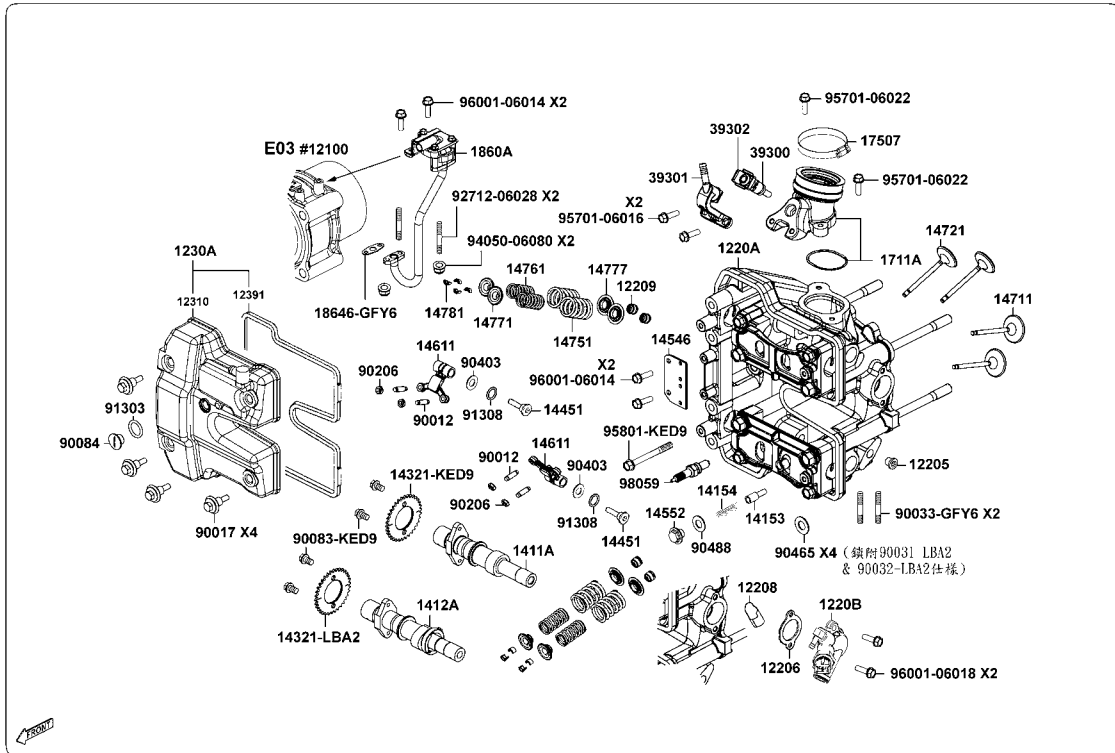

8. CYLINDER HEAD/VALVES

MXU 550EXi /MXU500i

SERVICE INFORMATION

GENERAL INSTRUCTIONS

- The cylinder head can be serviced with the engine installed in the frame. Coolant in the radiator and water jacket must be drained first.
- When assembling, apply molybdenum disulfide grease or engine oil to the valve guide movable parts and valve arm sliding surfaces for initial lubrication.
- The valve rocker arms are lubricated by engine oil through the cylinder head engine oil passages. Clean and unclog the oil passages before assembling the cylinder head.
- After disassembly, clean the removed parts and dry them with compressed air before inspection.
- After removal, mark and arrange the removed parts in order. When assembling, install them in the reverse order of removal.

SPECIFICATIONS

Unit: mm

Item		Standard	Service Limit
Valve clearance (cold)	IN	0.1 mm	—
	EX	0.1 mm	—
Cylinder head compression pressure		15 kg/cm ²	—
Cylinder head warpage		—	0.05
Camshaft runout		—	0.05
Camshaft cam height	IN	37.2614	37.11
	EX	37.0084	36.86
Valve rocker arm I.D.	IN	10 ~10.015	10.1
	EX	10 ~10.015	10.1
Valve rocker arm shaft O.D.	IN	9.975 ~9.99	9.9
	EX	9.975~9.99	9.9
Rocker arm to shaft clearance		0.009 ~0.042	0.1
Valve stem O.D.	IN	4.975 ~4.99	4.925
	EX	4.955 ~4.97	4.915
Valve guide I.D.	IN	5 ~5.015	5.03
	EX	5 ~5.015	5.03
Valve stem-to-guide clearance	IN	0.01 ~0.037	0.08
	EX	0.03 ~0.057	0.1

8. CYLINDER HEAD/VALVES

TORQUE VALUES

Cylinder head bolt (1 – 4)	4.8 kgf-m (48 N-m)	Apply engine oil to threads
Cylinder head bolt (5 – 13)	2.3 kgf-m (23 N-m)	Apply engine oil to threads
Cylinder head nut	1 kgf-m (10 N-m)	
Cylinder head cover bolt	1 kgf-m (10 N-m)	
Breather separator bolt	1.3 kgf-m (13 N-m)	
Cam chain tensioner bolt	1.2 kgf-m (12 N-m)	
Tensioner sealing bolt	1 kgf-m (10 N-m)	
Rocker arm shaft	4.5 kgf-m (45 N-m)	
Cam chain guide pivot bolt	2 kgf-m (20 N-m)	
Water joint bolt	1.2 kgf-m (12 N-m)	

SPECIAL TOOLS

Valve spring compressor	A120E00040
-------------------------	------------

TROUBLESHOOTING

- The poor cylinder head operation can be diagnosed by a compression test or by tracing engine top-end noises.

Poor performance at idle speed

- Compression too low

Compression too low

- Incorrect valve clearance adjustment
- Burned or bend valves
- Incorrect valve timing
- Broken valve spring
- Poor valve and seat contact
- Leaking cylinder head gasket
- Warped or cracked cylinder head
- Poorly installed spark plug

Compression too high

- Excessive carbon build-up in combustion chamber

White smoke from exhaust muffler

- Worn valve stem or valve guide
- Damaged valve stem oil seal

Abnormal noise

- Incorrect valve clearance adjustment
- Sticking valve or broken valve spring
- Damaged or worn camshaft
- Worn cam chain tensioner
- Worn camshaft and rocker arm

8. CYLINDER HEAD/VALVES

CYLINDER COMPRESSION TEST

Warm up the engine to normal operating temperature.

Stop the engine and remove the spark plug cap and remove the spark plug (refer to the “**SPARK PLUG**” section in the chapter 3).

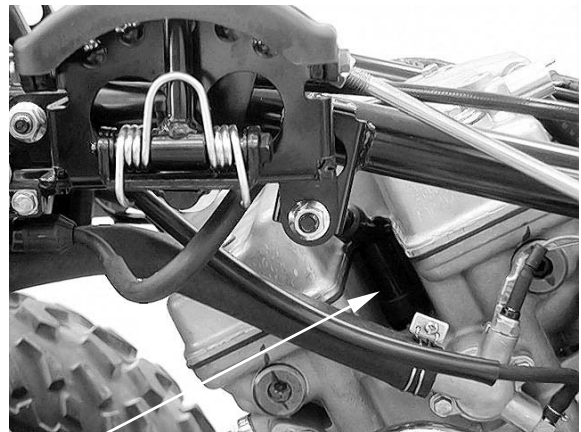

Park Plug Cap

Install a compression gauge into the spark plug hole.

Open the throttle all the way and crank the engine with the starter motor until the gauge reading stops rising.

The maximum reading is usually reached 4 – 7 seconds.

* To avoid discharging the battery, do not operate the starter motor for more than seven seconds.

Compression Gauge

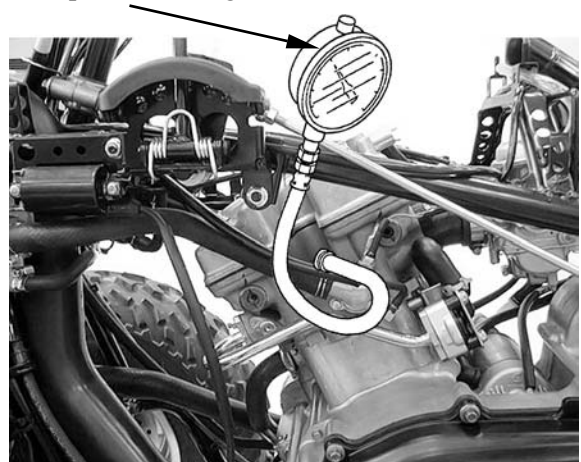

Compression pressure:

15 kg/cm² (1500 kPa, 213 psi)

Low compression can be caused by:

- ♦ Blown cylinder head gasket
- ♦ Improper valve adjustment
- ♦ Valve leakage
- ♦ Worn piston ring or cylinder

High compression can be caused by:

- ♦ Carbon deposits in combustion chamber or on piston head

8. CYLINDER HEAD/VALVES

CYLINDER HEAD COVER REMOVAL/INSTALLATION

REMOVAL

Disconnect the crankcase breather hose from the cylinder head cover (refer to the “ENGINE REMOVAL” section in the chapter 7).

Remove the four bolts/rubber washers and cylinder head cover.

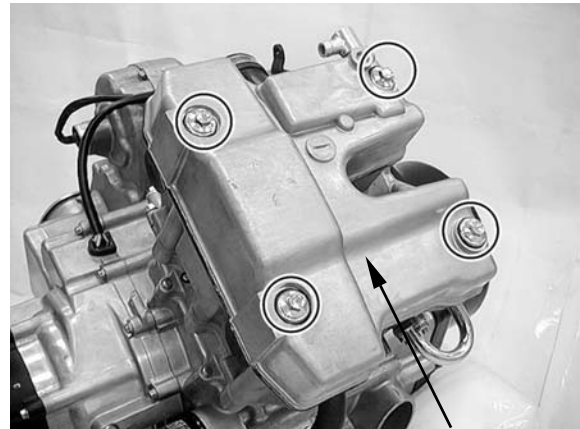

Cylinder Head Cover

Remove the cylinder head cover packing.

INSTALLATION

Apply fluid gasket (threebond: 1215) to the mating surface of the cylinder head cover, then install the packing.

Cylinder Head Cover Packing

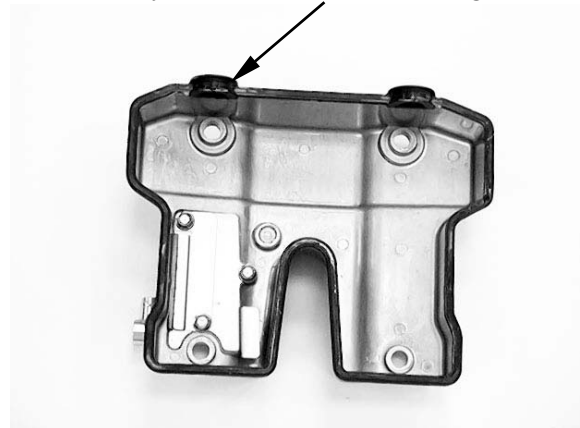

Install the cylinder head cover.
Install and tighten the four bolts/rubber washers to the specified torque in a crisscross pattern.

Torque: 1.0 kgf-m (10 N-m)

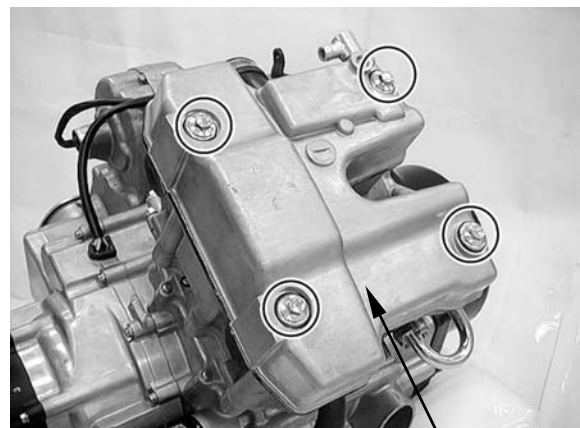

Cylinder Head Cover

8. CYLINDER HEAD/VALVES

CYLINDER HEAD COVER DISASSEMBLY/ASSEMBLY

DISASSEMBLY

Remove the three bolts and breather separator.



Remove the gasket.

ASSEMBLY

Assembly is in the reverse order of disassembly.

Torque:

Breather separator bolt:

1.3 kgf-m (13 N-m,)

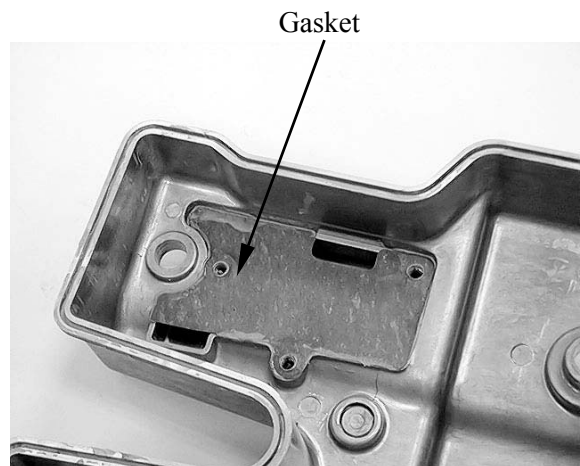

8. CYLINDER HEAD/VALVES

CAMSHAFT REMOVAL/INSPECTION/ INSTALLATION

REMOVAL

Remove the cylinder head cover (refer to the “**CYLINDER HEAD COVER REMOVAL/INSTALLATION**” section in this chapter).

Turn the crankshaft clockwise and align the “T” mark on the flywheel with the index mark on the right crankcase cover (refer to the “**VALVE CLEARANCE**” section in the chapter 3).

Remove the cam chain tensioner lifter sealing bolt, spring and sealing washer.

Remove the two bolts, cam chain tensioner and gasket.

Remove the two bolts and cam chain guide.

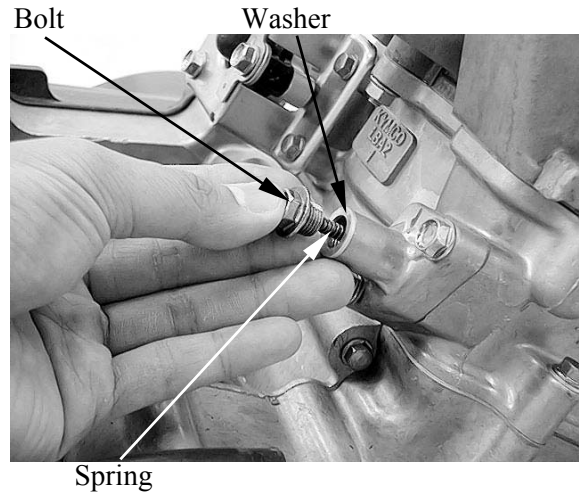

Cam Chain Tensioner/Gasket



Cam Chain Guide

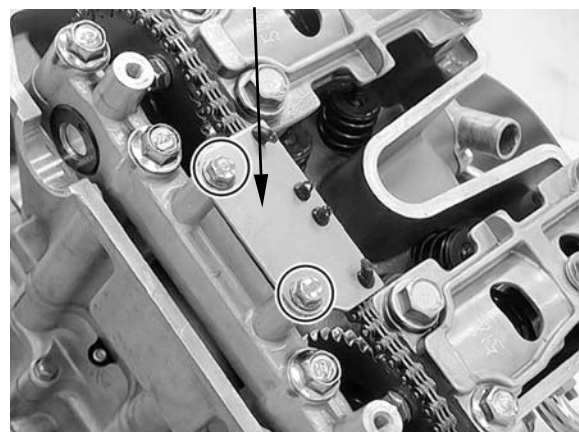

8. CYLINDER HEAD/VALVES

Loosen and remove the eight camshaft holder bolts in a crisscross pattern in several steps.

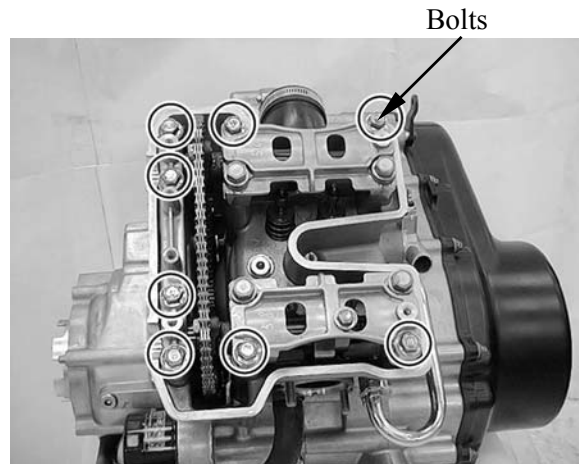

Loosen and remove the four camshaft holder bolts/washers in a crisscross pattern in several steps, then remove the camshaft holders.

* Suspend the cam chain with a piece of wire to prevent the chain from falling into the crankcase.

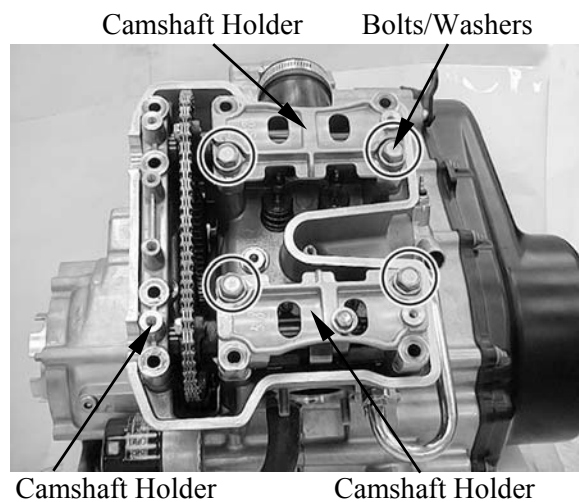

Remove the camshafts.

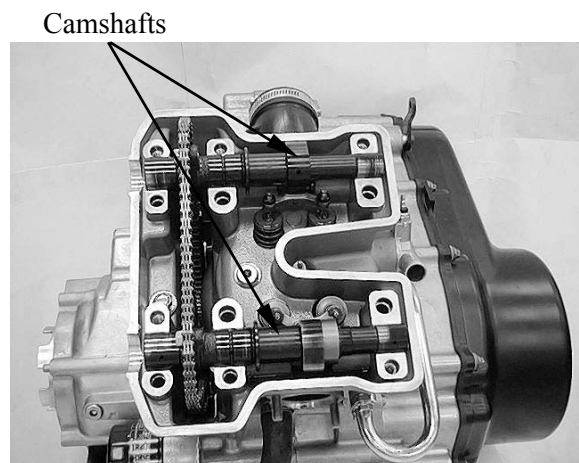

8. CYLINDER HEAD/VALVES

INSPECTION

Cam chain guide

Inspect the cam chain slipper surface of the cam chain guide for wear or damage.

Cam Chain Slipper

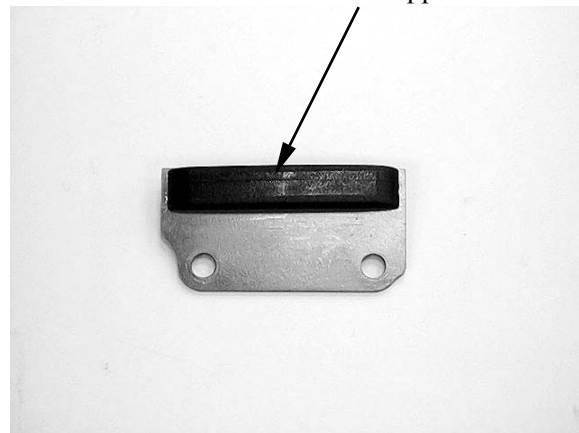

Camshaft holder

* Always replace the camshaft holder and cylinder head in pairs

Inspect the camshaft surface of each camshaft holder for scoring, scratches, or evidence of insufficient lubrication.

Camshaft Holders

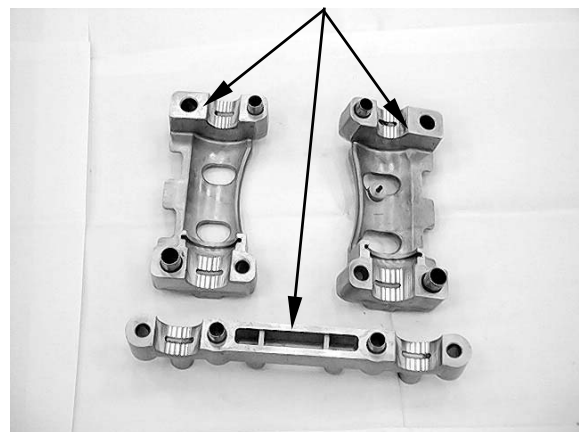

Check the stop pin spring on the exhaust camshaft holder for damage.

Replace the stop pin assembly with a new one if the spring is damaged.

Stop Pin

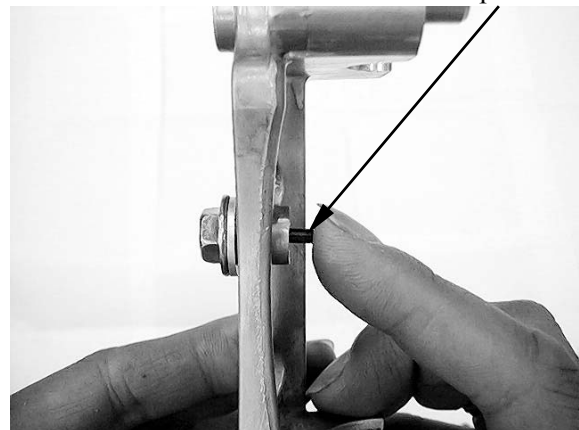

8. CYLINDER HEAD/VALVES

Camshaft

Support both ends of the camshaft with V-blocks and check the camshaft runout with a dial gauge.

Service limit: 0.05 mm

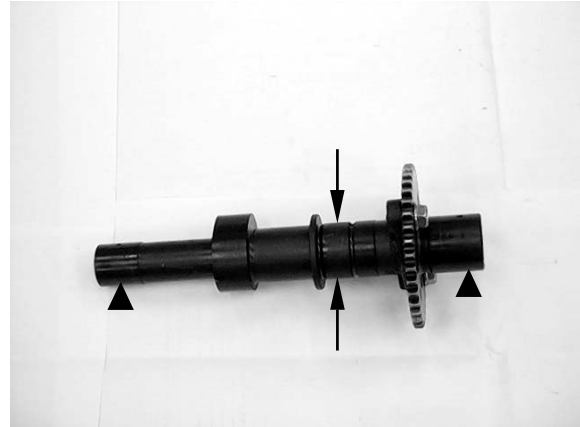

Inspect camshaft lobes for pitting/scratches/blue discoloration.

Measure the cam lobe height.

Service Limits: IN : 37.11 mm
EX: 36.86 mm

If any defects are found, replace the camshaft with a new one, then inspect lubrication system.

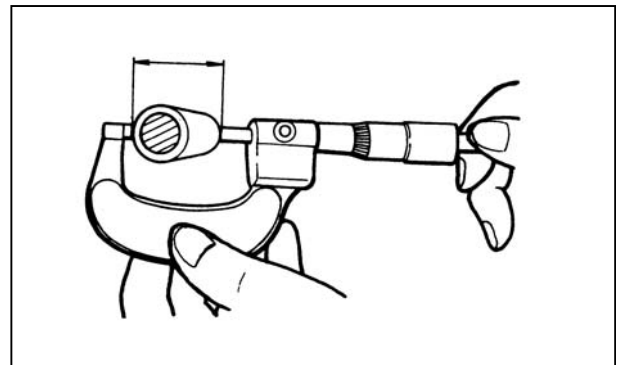

Check the decompression system by turning the de-compressor cam on the exhaust camshaft.

You should be able to turn the de-compressor cam clockwise smoothly, but the de-compressor should not turn counterclockwise.



8. CYLINDER HEAD/VALVES

Cam chain tensioner

Check the one-way cam operation (tensioner)
Unsmooth operation → Replace.



INSTALLATION

Turn the crankshaft clockwise, align the “T” mark on the flywheel with the index mark on the right crankcase cover (refer to the “**VALVE CLEARANCE**” in chapter 3).

Apply molybdenum disulfide oil to the camshaft journals of the camshaft holder.



Apply molybdenum disulfide oil to the camshaft journals of the cylinder head.

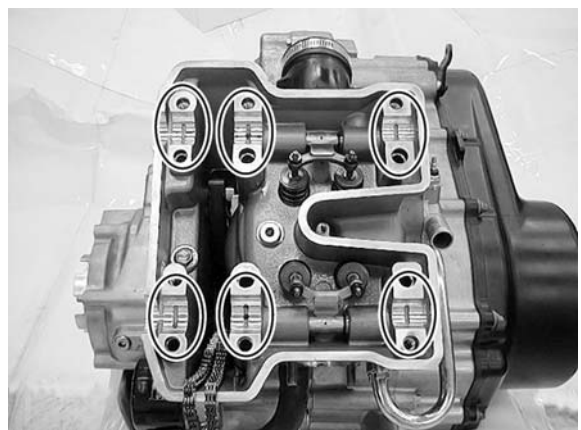

8. CYLINDER HEAD/VALVES

Install the cam chain over the cam sprockets and then install the intake and exhaust camshafts.

- *
 - ◆ Install each camshafts to the correct locations.
 “IN”: no de-compressor cam
 “EX”: has a de-compressor cam
 - ◆ Make sure the timing marks on the cam sprockets are flush with the cylinder head upper surface and punch marks face upward as shown.

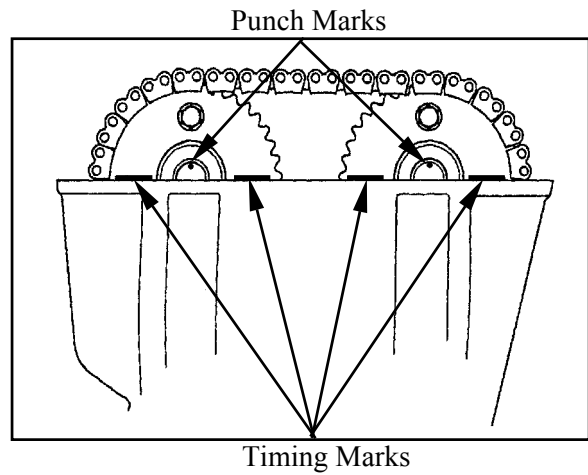

Install intake and exhaust camshaft holders to the correct locations.

- *
 - ◆ Install each camshaft holders to the correct locations.
 “IN”: no stop pin.
 “EX”: has a stop pin.

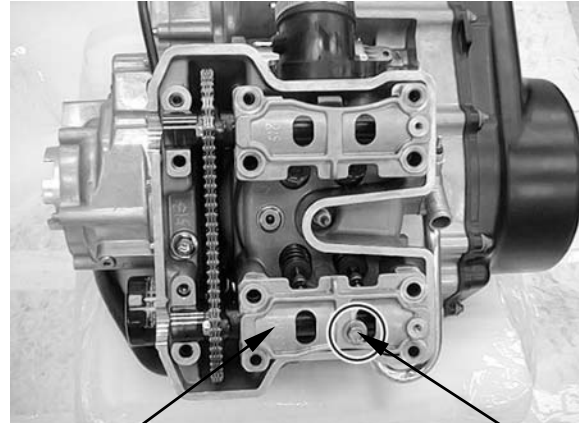

Exhaust Camshaft Holder

Stop Pin

8. CYLINDER HEAD/VALVES

Apply engine oil to cylinder head bolt (No. 1 – 8) threads.

Install the four bolts (No. 5 – 8).

Install the four bolts/washers (No. 1 – 4).

Tighten the holder bolts (No. 1 – 8) in a crisscross pattern in five steps to the specified torque as follow diagram.

Tighten the bolts to the specified torque in sequence									
kgf-m (N-m, lbf-ft)									
	(1)	(2)	(3)	(4)	(5)	(6)	(7)	(8)	
Step 1	2.4 (24, 17)	←	←	←	1.2 (12, 9)	←	←	←	
Step 2	3.8 (38, 27)	←	←	←	2.3 (23, 17)	←	←	←	
Step 3	4.8 (48, 35)	←	←	←					

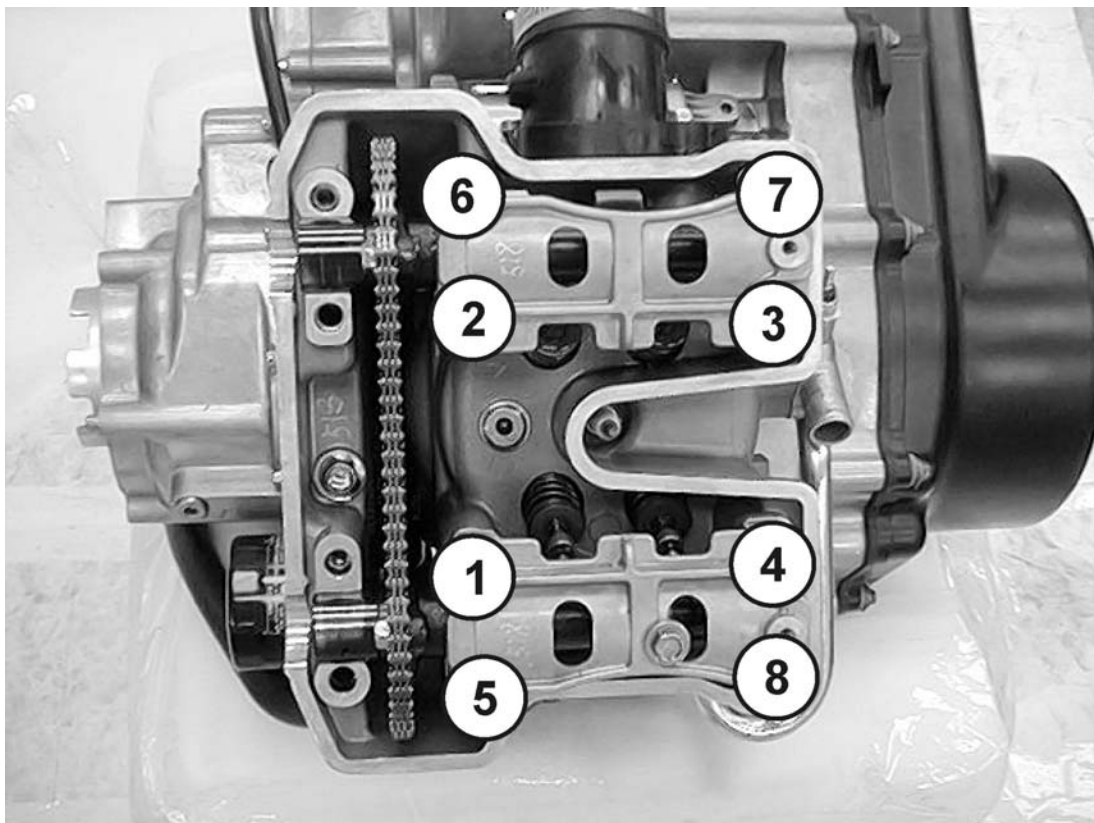

8. CYLINDER HEAD/VALVES

Apply engine oil to cylinder head bolt (No. 10 – 13) threads.

Install the common camshaft holder by arrow mark facing outside.

Install and tighten the holder bolts (No. 10 – 13) in a crisscross pattern in five steps to the specified torque as follow diagram.

Tighten the bolts to the specified torque in sequence								
kgf-m (N-m)								
	(10)	(11)	(12)	(13)				
Step 4	1.2 (12)	←	←	←				
Step 5	2.3 (23)	←	←	←				

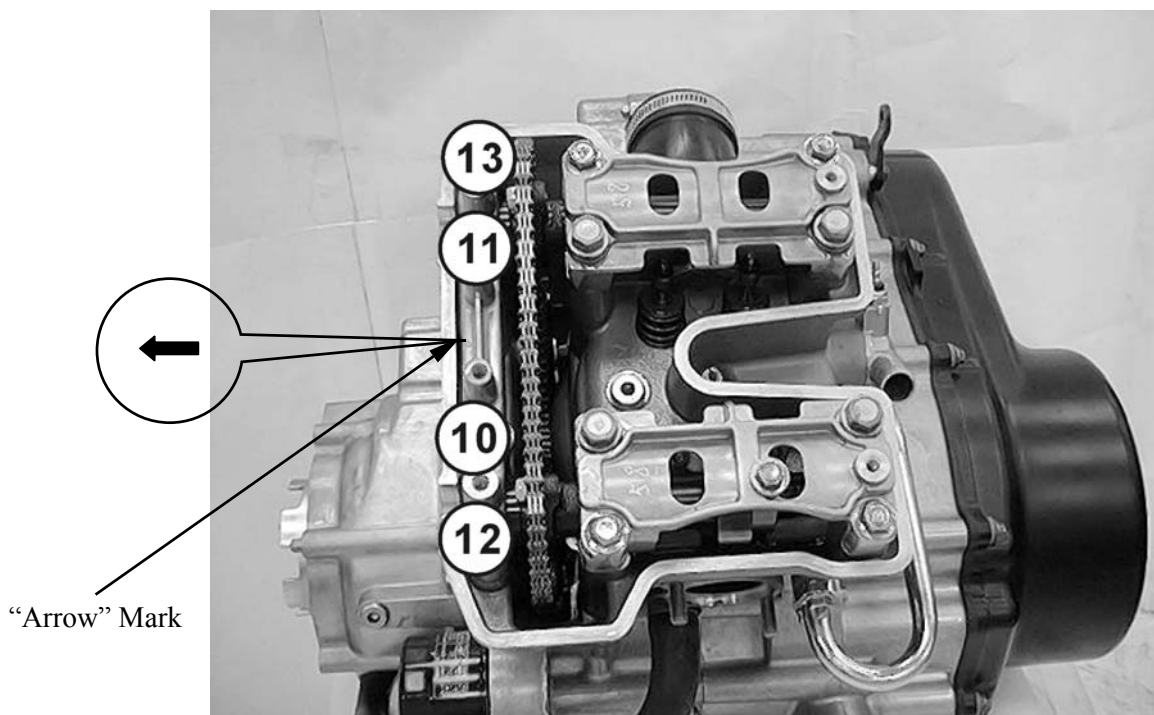

8. CYLINDER HEAD/VALVES

ROCKER ARMS REMOVAL/INSPECTION/ INSTALLATION

REMOVAL

Remove the camshafts (refer to the “**CAMSHAFT REMOVAL/INSPECTION/INSTALLATION**” section in this chapter).

Remove the rocker arm shafts and washers, then remove the rocker arms.

Rocker Arms

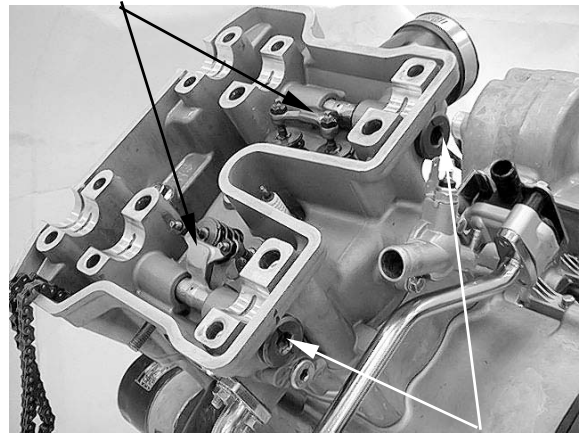

Rocker Arm Shafts/Washers

INSPECTION

Rocker arm shaft

Inspect the rocker arm shaft for blue discoloration or grooves.

If any defects are found, replace the rocker arm shaft with a new one, then inspect lubrication system.

Measure each rocker arm shaft O.D.

Measure the I.D. of each rocker arm.

Measure arm to shaft clearance.

Replace as a set if out of specification.

Service limits: 0.1 mm

Inspect the rocker arm bore, cam lobe contact surface and adjuster surface for wear/pitting/scratches/blue discoloration.

If any defects are found, replace the rocker arm shaft with a new one, then inspect lubrication system.

Measure each rocker arm shaft O.D.

Measure the I.D. of each rocker arm.

Measure arm to shaft clearance.

Replace as a set if out of specification.

Service limits: 0.1 mm

Rocker Arm Shaft



Rock Arm

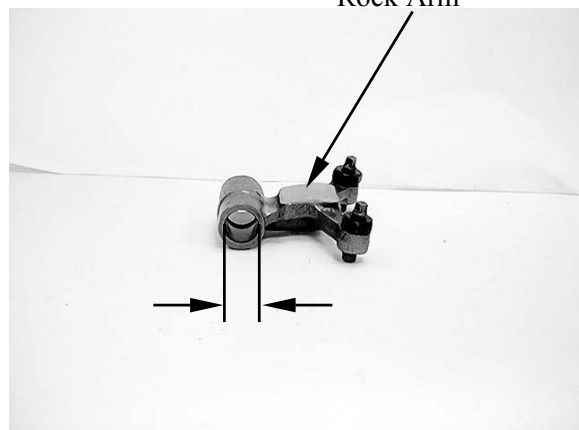

8. CYLINDER HEAD/VALVES

INSTALLATION

Apply engine oil to the rocker arms and rocker arm shafts

Install the rocker arms, rocker arm shafts and washers.
Tighten the rocker arm shaft to the specified torque.

Torque: 4.5 kgf-m (45 N-m, 32 lbf-ft)

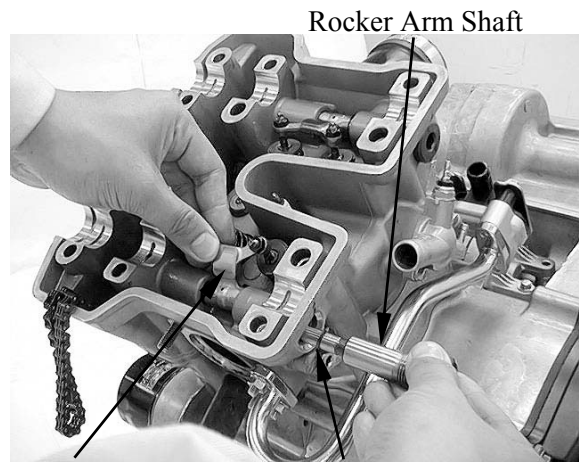

Rock Arm

Washer

8. CYLINDER HEAD/VALVES

CYLINDER HEAD REMOVAL/INSTALLATION

* Always replace the camshaft holder and cylinder head in pairs

Remove the camshafts (refer to the “CAMSHAFT REMOVAL/INSPECTION/INSTALLATION” section in this chapter)

Remove the two bolts and intake pipe.

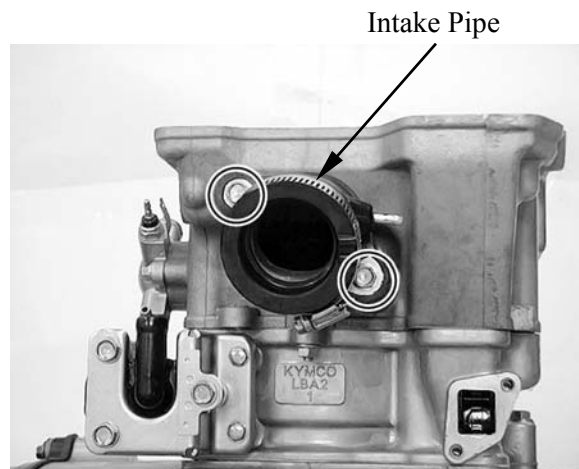

Remove the five bolts, then remove the pair reed valve cover and holder.

Remove the two nuts, then remove the pair reed valve and gasket.

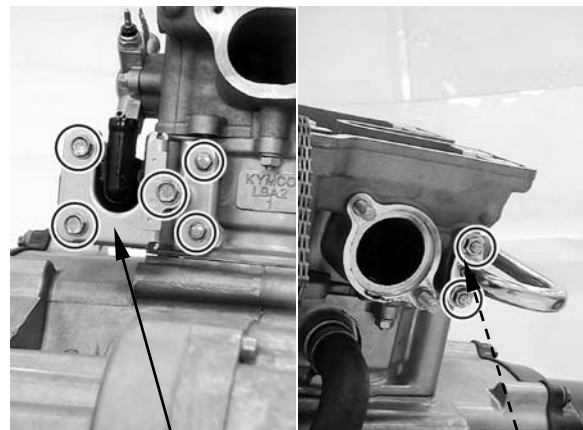

Pair Reed Valve Cover/Holder

Gasket

Remove the two bolts, water joint, gasket and water stop collar.



Water Joint/Gasket/Water Stop Collar

8. CYLINDER HEAD/VALVES

Remove the two nuts under the cylinder head.

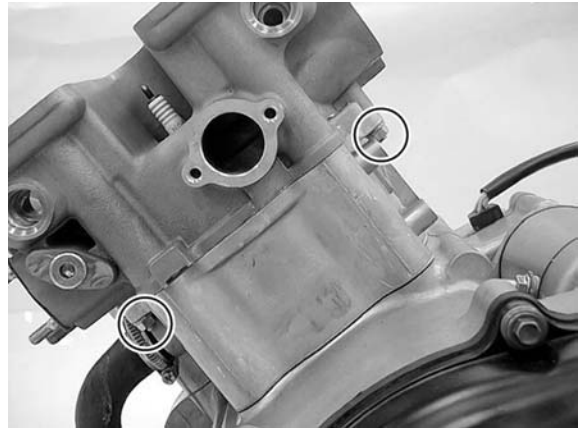

Remove the bolt and then remove the cylinder head.

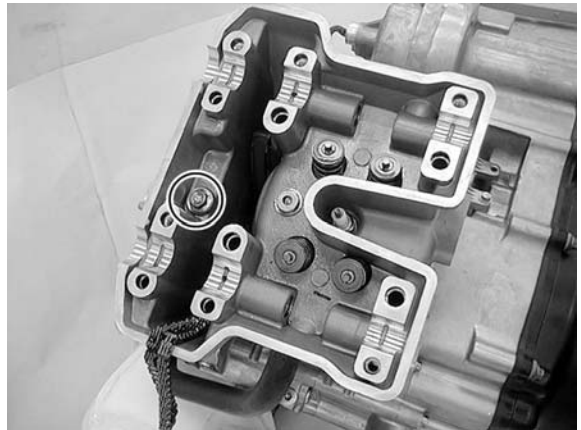

Remove the dowel pins and gasket.

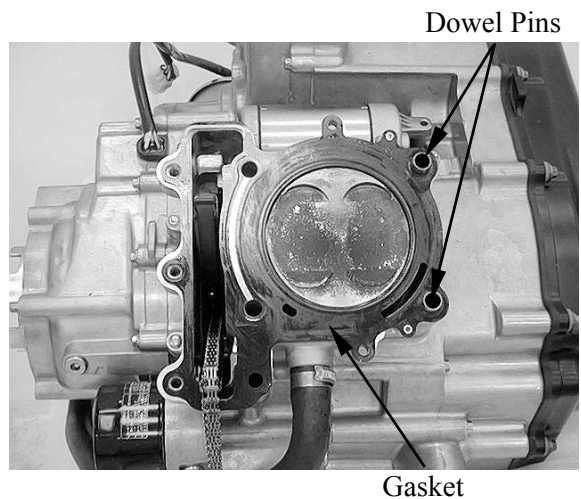

8. CYLINDER HEAD/VALVES

INSTALLATION

Install the dowel pins and new gasket as shown.

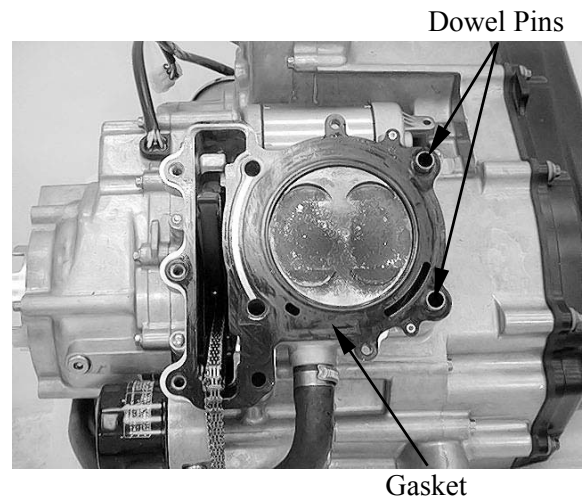

Install the cylinder head.

Apply engine oil to the cylinder head bolt (9) threads.

Install the bolt (9) but do not tighten it.

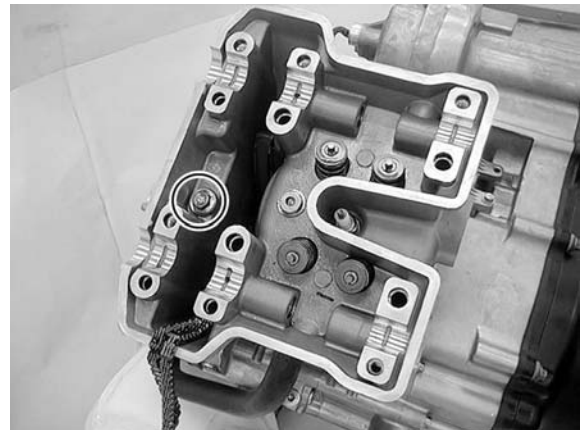

Install the camshafts, intake camshaft holder and exhaust camshaft holder (refer to the “CAMSHAFT REMOVAL/INSPECTION/INSTALLATION” section in this chapter).

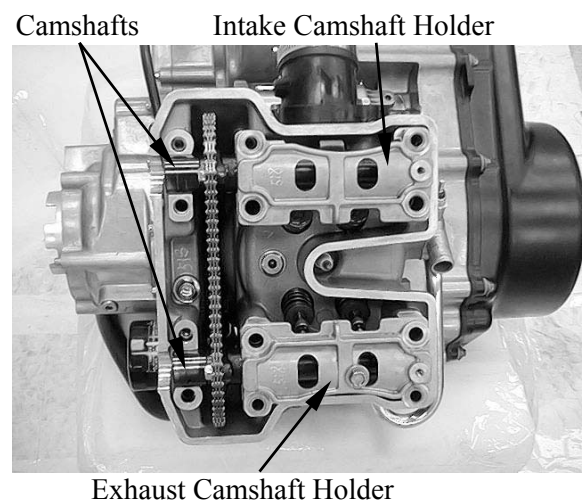

8. CYLINDER HEAD/VALVES

MXU 550EXi /MXU500i

Apply engine oil to cylinder head bolt (No. 1 – 8) threads.

Install the four bolts (No. 5 – 8).

Install the four bolts/washers (No. 1 – 4).

Tighten the holder bolts (No. 1 – 9) in a crisscross pattern in five steps to the specified torque as follow diagram.

Tighten the bolts to the specified torque in sequence									
kgf-m (N-m)									
	(1)	(2)	(3)	(4)	(5)	(6)	(7)	(8)	(9)
Step 1	2.4 (24)	←	←	←	1.2 (12)	←	←	←	←
Step 2	3.8 (38)	←	←	←	2.3 (23)	←	←	←	←
Step 3	4.8 (48)	←	←	←					

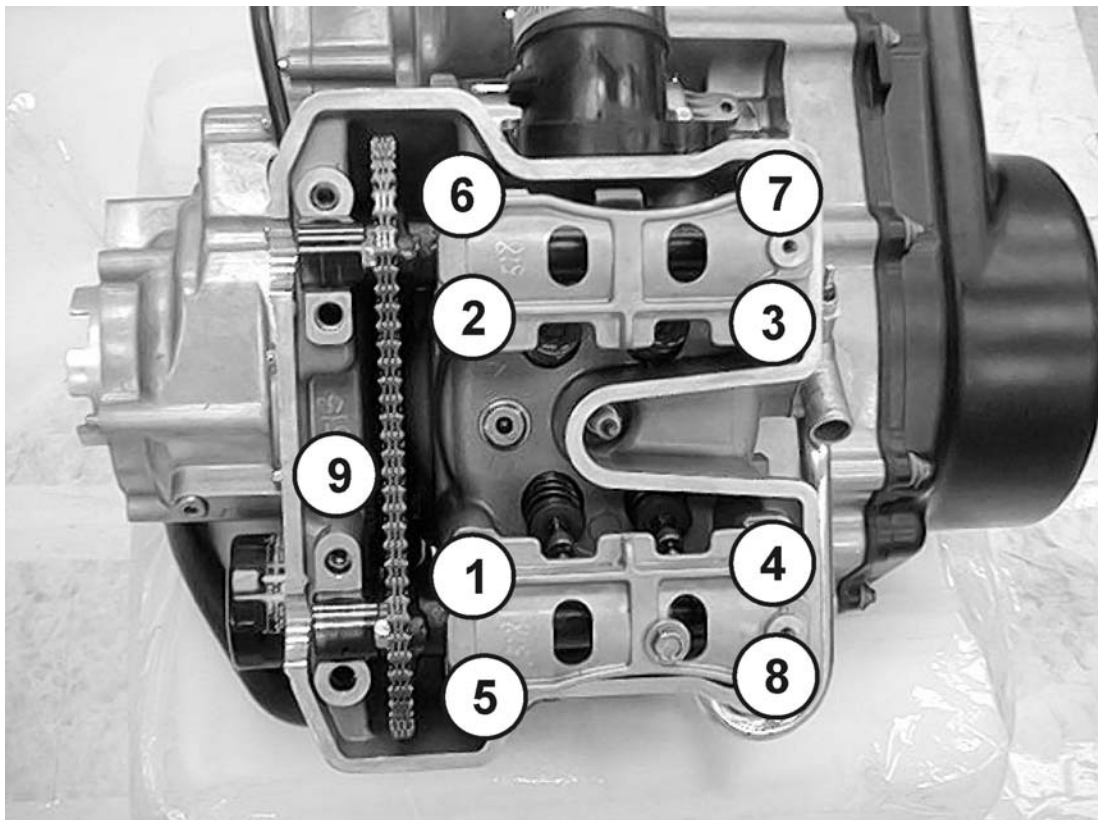

8. CYLINDER HEAD/VALVES

Apply engine oil to cylinder head bolt (No. 10 – 13) threads.

Install the common camshaft holder by arrow mark facing outside.

Install and tighten the holder bolts (No. 10 – 13) in a crisscross pattern in five steps to the specified torque as follow diagram.

Tighten the bolts to the specified torque in sequence									
kgf-m (N-m, lbf-ft)									
	(10)	(11)	(12)	(13)					
Step 4	1.2 (12, 9)	←	←	←					
Step 5	2.3 (23, 17)	←	←	←					

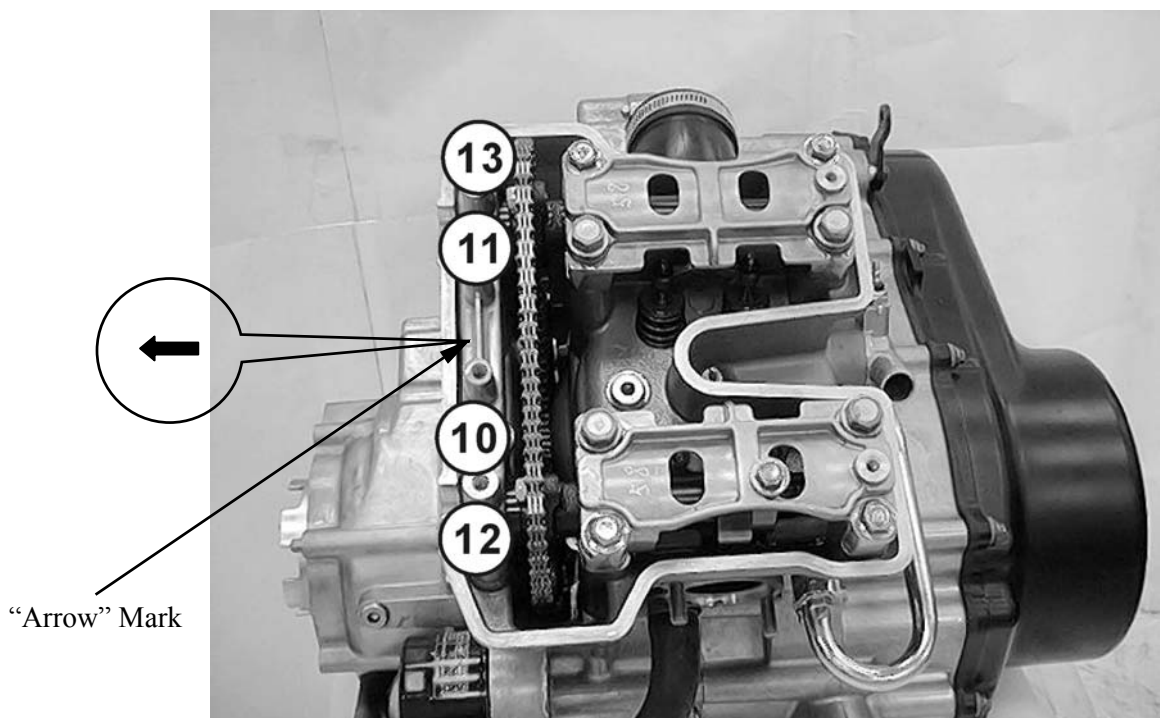

8. CYLINDER HEAD/VALVES

Install and tighten the two nuts under the cylinder head to the specified torque.

Torque: 1 kgf-m (10 N-m)

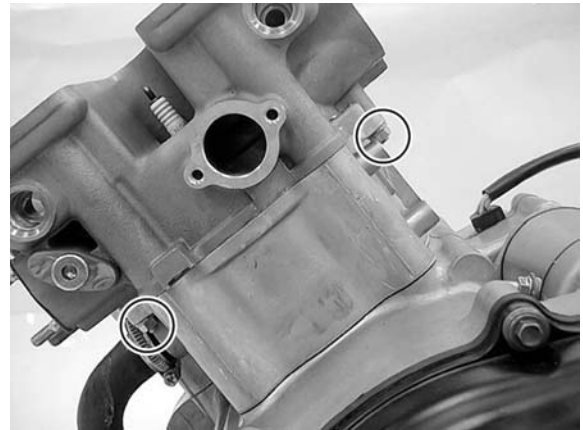

Install the water stop collar, gasket and water joint.
Install and tighten the two bolts to the specified torque.

Torque: 1.2 kgf-m (12 N-m)

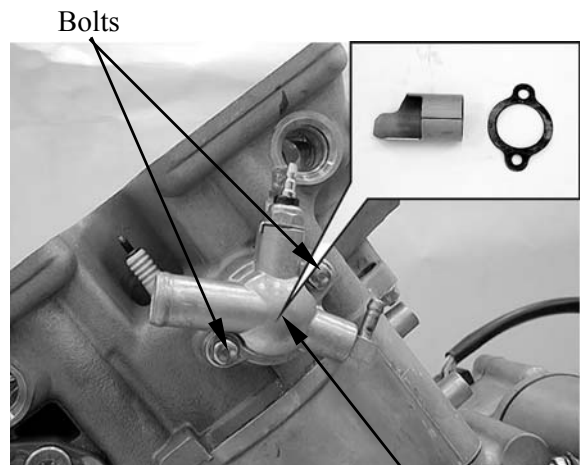

Water Joint/Gasket/Water Stop Collar

Install gasket and pair reed valve.
Install and tighten the five bolts and two nut securely.

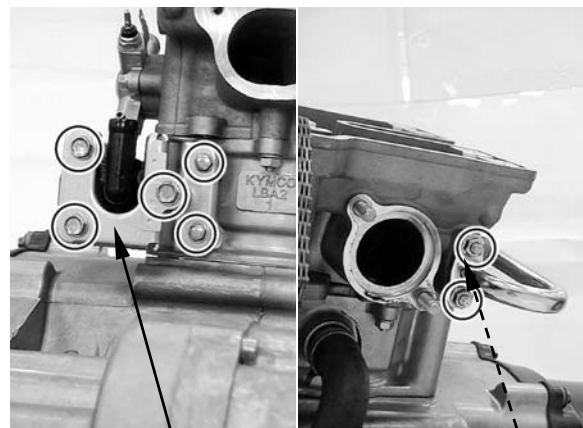

Pair Reed Valve Cover/Holder

Gasket

8. CYLINDER HEAD/VALVES

Install the new O-ring onto the intake pipe.



Install the intake pipe and tighten the two bolts securely.

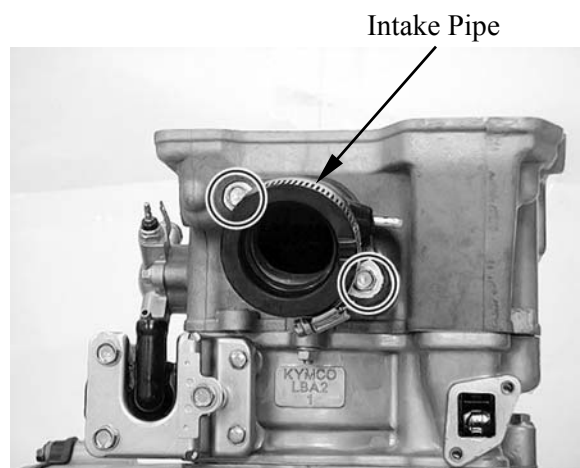

8. CYLINDER HEAD/VALVES

CYLINDER HEAD DISASSEMBLY/INSPECTION/ ASSEMBLY

Remove the cylinder head (refer to the “**CYLINDER HEAD REMOVAL/INSTALLATION**” section in this chapter).

Remove the valve spring cotters, retainers, springs, spring seats, oil seals and valves using a valve spring compressor.

Valve Spring Compressor

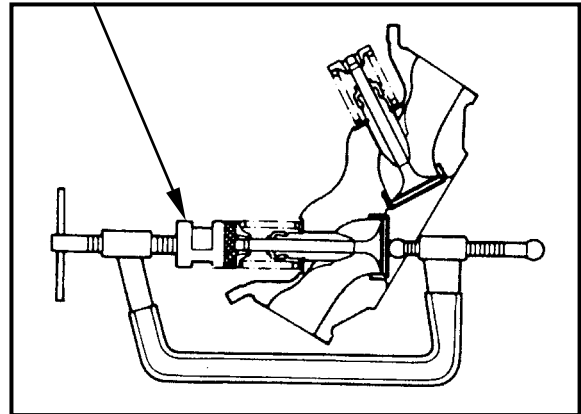

- *
- Be sure to compress the valve springs with a valve spring compressor.
 - Mark all disassembled parts to ensure correct reassembly.

Special tool:

Valve Spring Cotters Retainers
Valve Spring Compressor A120E00040

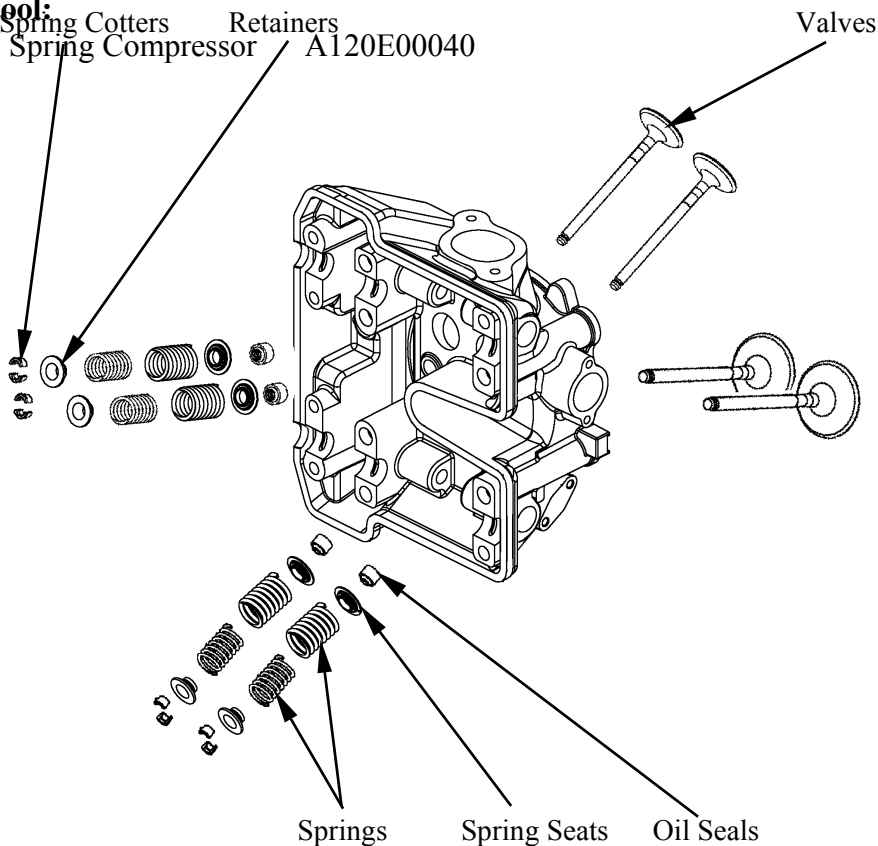

8. CYLINDER HEAD/VALVES

INSPECTION

Valve /Valve guide

Inspect each valve for bending, burning, scratches or abnormal stem wear.
If any defects are found, replace the valve with a new one.

Check valve movement in the guide.

Measure each valve stem O.D.

Measure each valve guide I.D.

Subtract each valve stem O.D. from the corresponding guide I.D. to obtain the stem-to-guide clearance.

Service limits:

IN: 0.08 mm

EX: 0.1 mm

* If the stem-to-guide clearance exceeds the service limits, replace the cylinder head is necessary.

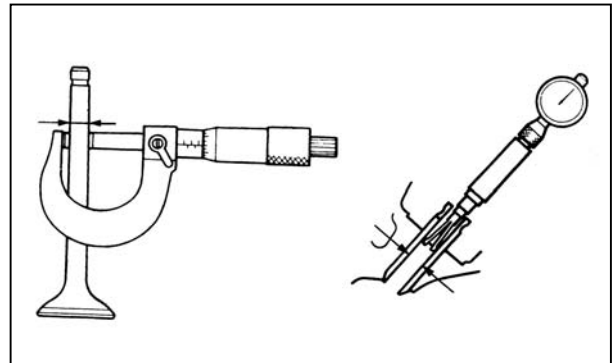

Cylinder head

Check the spark plug hole and valve areas for cracks.

Check the cylinder head for warpage with a straight edge and feeler gauge.

Service Limit: 0.05 mm (0.002 in)

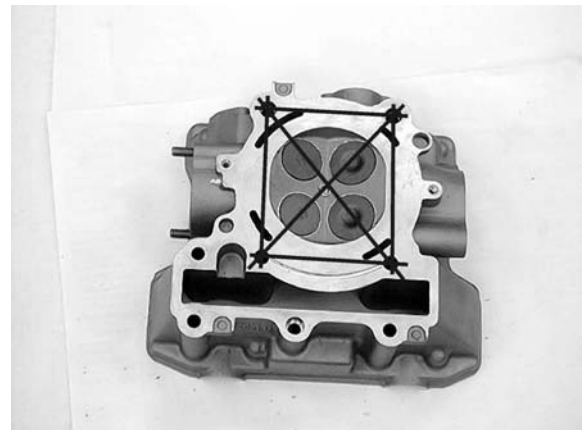

Valve spring

Measure the free length of the inner and outer valve springs.

Service Limit:

Inner: 33.4 mm

Outer: 38 mm

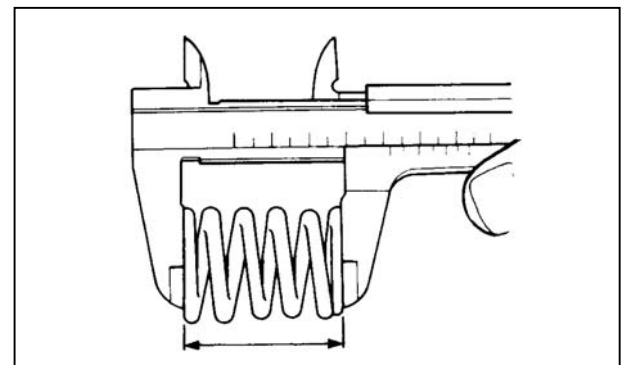

8. CYLINDER HEAD/VALVES

Measure compressed force (valve spring) and installed length.

Replace if out of specification.

Standard:

Inner: 3.5 kg (at 28.7 mm)

Outer: 13 kg (at 31.43 mm)

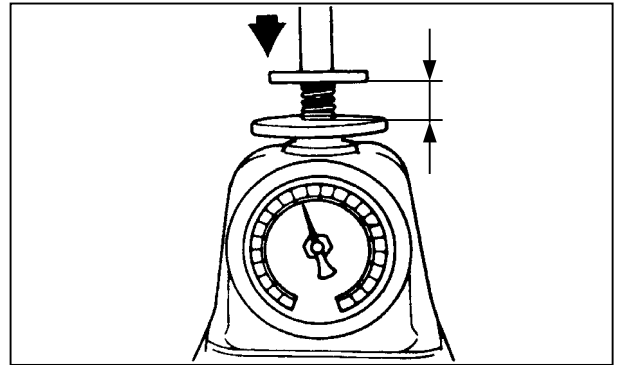

Measure the spring tilt.

Replace if out of specification.

Standard:

Inner: 1.2 mm

Outer: 1.2 mm

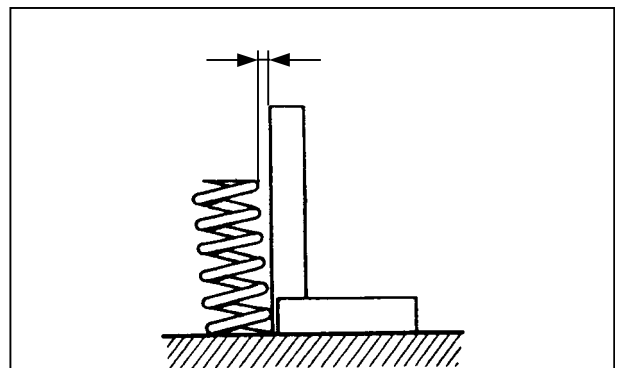

ASSEMBLY

Install the valve spring seats and oil seal.

* Be sure to install new oil seal.

Lubricate each valve with engine oil and insert the valves into the valve guides.

Install the valve springs and retainers.

Compress the valve springs using the valve spring compressor, then install the valve cotters.

Valve Spring Compressor

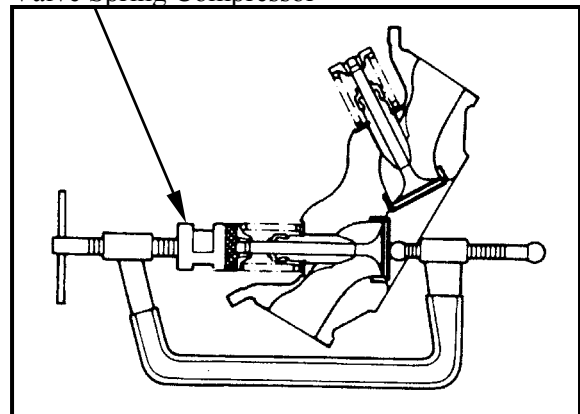

* • When assembling, a valve spring compressor must be used.
 • Install the cotters with the pointed ends facing down from the upper side of the cylinder head.

Special tool:

Valve Spring Compressor A120E00040

8. CYLINDER HEAD/VALVES

Tap the valve stems gently with a plastic hammer for 2~3 times to firmly seat the cotters.

* Be careful not to damage the valves.

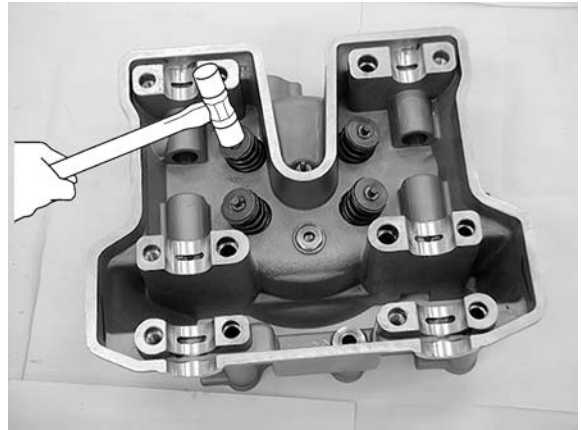

8. CYLINDER HEAD/VALVES

CAM CHAIN REMOVAL/INSPECTION/ INSTALLATION

REMOVAL

Remove the cylinder (refer to the “CYLINDER AND PISTON REMOVAL/INSPECTION/INSTALLATION” section in the chapter 9). Remove the oil pump drive chain (refer to “OIL PUMP REMOVAL/INSTALLATION” section in the chapter 4).

Remove the cam chain from the right crankcase.

Remove the two bolts and cam chain guides.

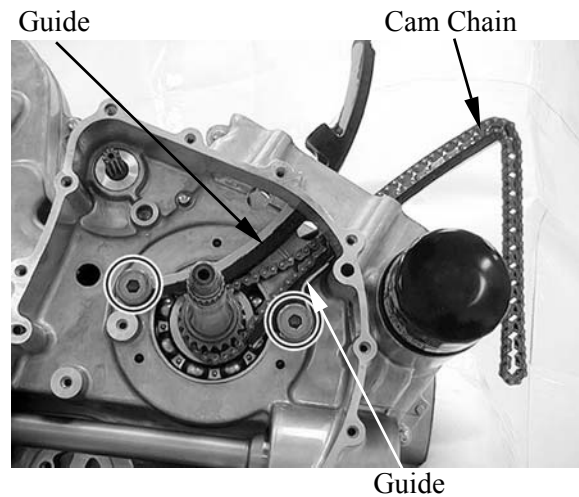

INSPECTION

Cam chain guide

Inspect the cam chain slipper surface of the cam chain guide for wear or damage.

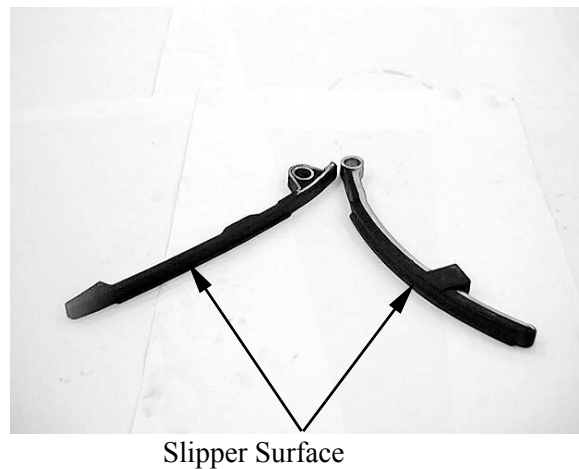

Cam chain

Inspect the cam chain for cracks or stiff.

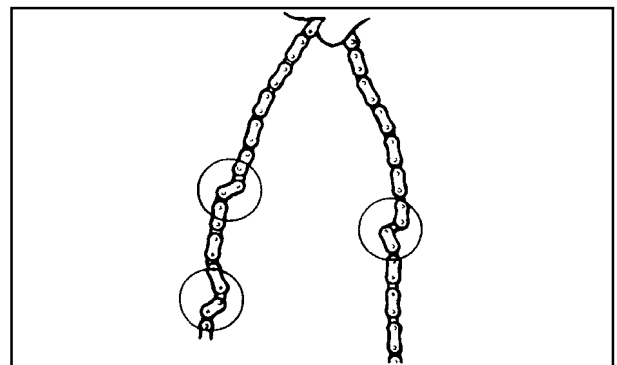

8. CYLINDER HEAD/VALVES

INSTALLATION

Installation is in the reverse order of removal.

Install the cam chain guides to the right crankcase and tighten the bolts to the specified torque.

Torque: 2 kgf-m (20 N-m)

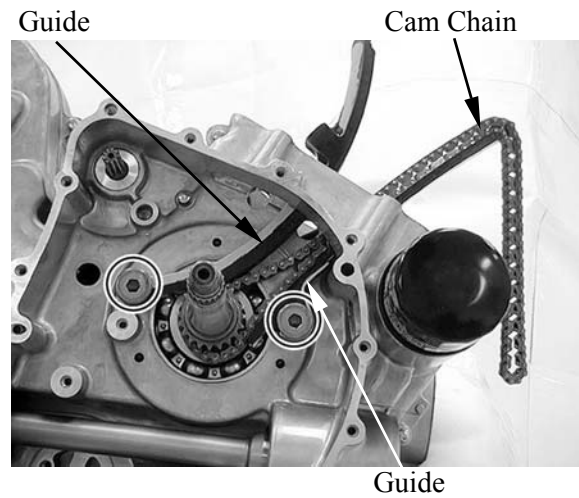

9. CYLINDER/PISTON

CYLINDER/PISTON

SCHEMATIC DRAWING	9-1
SERVICE INFORMATION.....	9-2
TROUBLESHOOTING.....	9-2
CYLINDER AND PISTON REMOVAL/INSPECTION/ INSTALLATION	9-3

9. CYLINDER/PISTON

SCHEMATIC DRAWING

LEA0AE(FR) E03

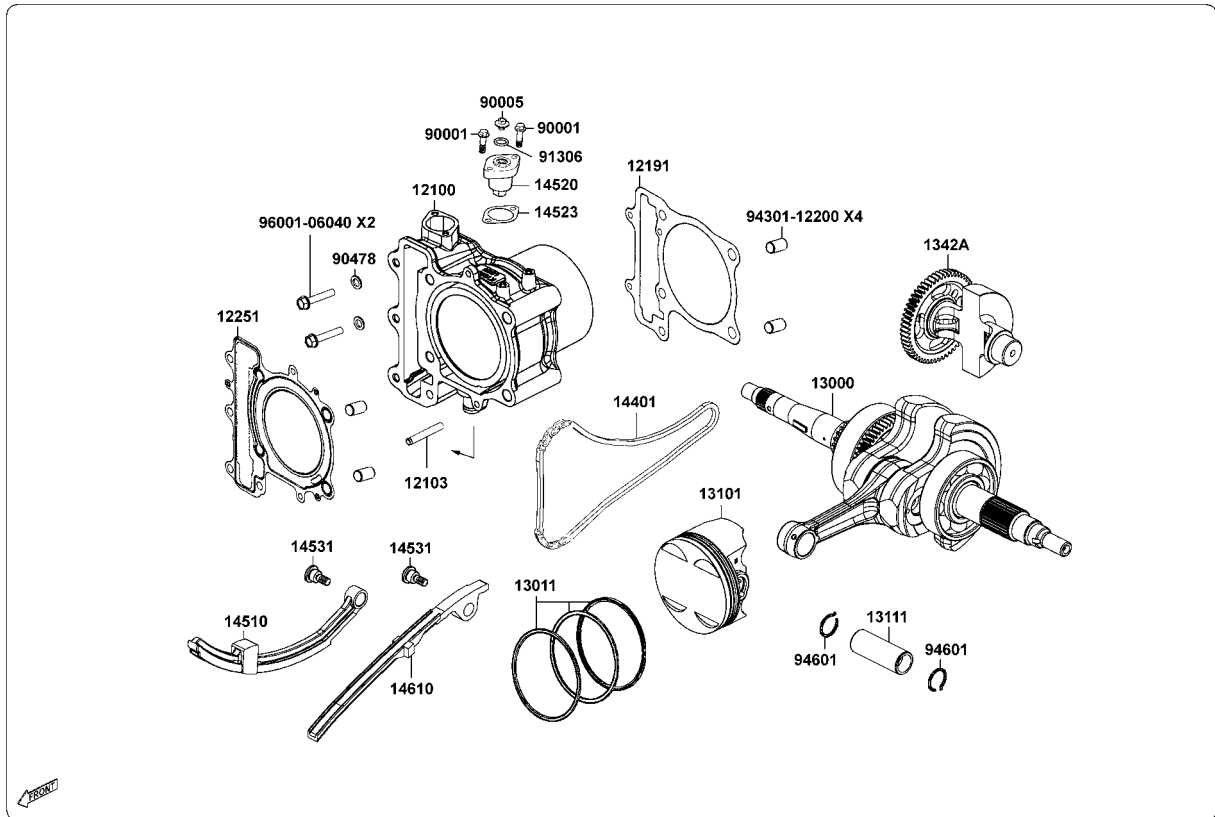

9. CYLINDER/PISTON

SERVICE INFORMATION

GENERAL INSTRUCTIONS

- The cylinder and piston can be serviced with the engine installed in the frame.
- When installing the cylinder, use a new cylinder gasket and make sure that the dowel pins are correctly installed.
- After disassembly, clean the removed parts and dry them with compressed air before inspection.

SPECIFICATIONS

Unit: mm (in)

Item		Standard	Service Limit	
Cylinder	I.D.	92.005 (3.6802)~92.015 (3.6806)	92.1 (3.684)	
	Warpage	0.01 (0.0004)	0.05 (0.002)	
	Cylindricity	0.01 (0.0004)	0.1 (0.004)	
	True roundness	0.01 (0.0004)	0.1 (0.004)	
Piston, piston ring	Ring-to-groove clearance	top	0.03 (0.0012)~0.065 (0.0026)	0.08 (0.003)
		Second	0.015 (0.0006)~0.05 (0.002)	0.065 (0.0026)
	Ring end gap	top	0.15 (0.006)~0.3 (0.012)	0.5 (0.02)
		Second	0.03 (0.012)~0.45 (0.018)	0.65 (0.026)
		Oil side rail	0.2 (0.008)~0.7 (0.028)	1 (0.04)
	Piston O.D.	91.96 (3.6784)~91.98 (3.6793)	91.9 (3.676)	
	Piston O.D. measuring position	10 mm from bottom of skirt	—	
	Piston-to-cylinder clearance	0.01 (0.0004)~0.045 (0.0018)	0.1 (0.004)	
Piston pin hole I.D.	22.002 (0.8801)~22.008 (0.8803)	22.04 (0.8816)		
Piston pin O.D	21.994 (0.8798)~22 (0.88)	21.96 (0.8784)		
Piston-to-piston pin clearance	0.002 (0.0001)~0.014 (0.0006)	0.02 (0.001)		
Connecting rod small end I.D. bore	22.016 (0.8806)~22.034 (0.8814)	22.06 (0.8824)		

TORQUE VALUES

Cylinder bolt 1 kgf-m (10 N-m, 7.2 lbf-ft)

TROUBLESHOOTING

- When hard starting or poor performance at low speed occurs, check the crankcase breather for white smoke. If white smoke is found, it means that the piston rings are worn, stuck or broken.

Compression too low or uneven compression

- Worn or damaged cylinder and piston rings
- Worn, stuck or broken piston rings

Compression too high

- Excessive carbon build-up in combustion chamber or on piston head

Excessive smoke from exhaust muffler

- Worn or damaged piston rings
- Worn or damaged cylinder and piston

Abnormal noisy piston

- Worn cylinder, piston and piston rings
- Worn piston pin hole and piston pin
- Incorrectly installed piston

9. CYLINDER/PISTON

CYLINDER AND PISTON REMOVAL/INSPECTION/ INSTALLATION

REMOVAL

Remove the cylinder head (refer to “**CYLINDER HEAD REMOVAL/INSTALLATION**” section in the chapter 8).

Take the block pin out.
Remove the water hose from the cylinder.
Remove the two cylinder bolts/washers.
Remove the cylinder.

Remove the dowel pins and gasket.

Remove the piston pin clip.

* Place a clean shop towel in the crankcase to keep the piston pin clip from falling into the crankcase.

Press the piston pin out of the piston and remove the piston.

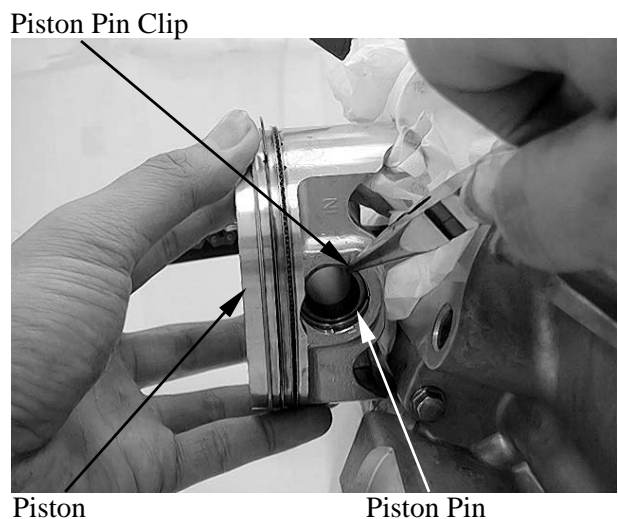
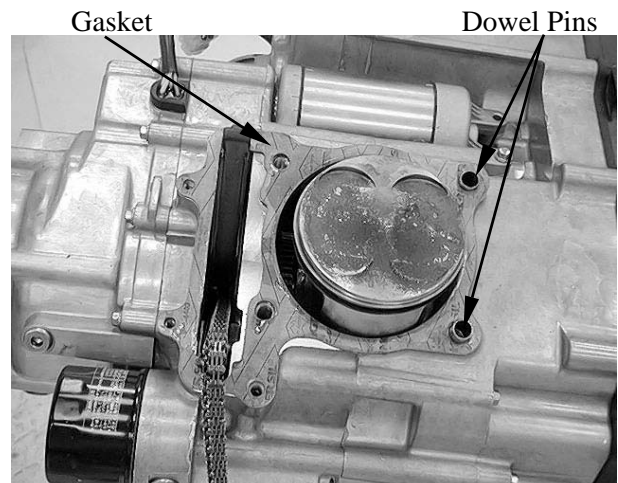
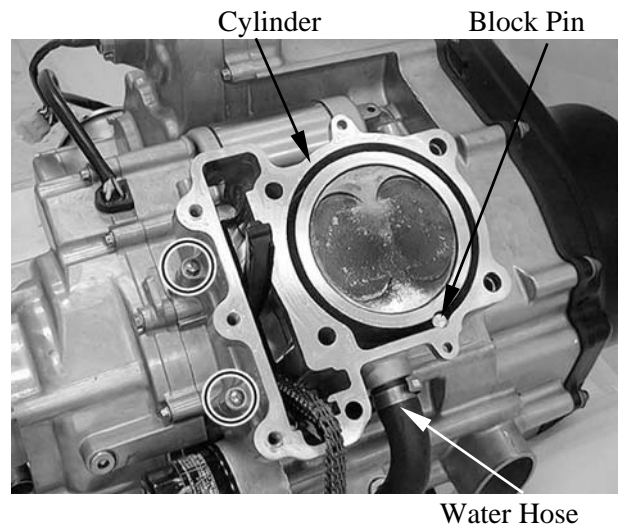

9. CYLINDER/PISTON

Spread each piston ring and remove it by lifting up at a point opposite the gap.

* Do not damage the piston ring by spreading the ends too far.

Clean carbon deposits from the piston ring grooves.

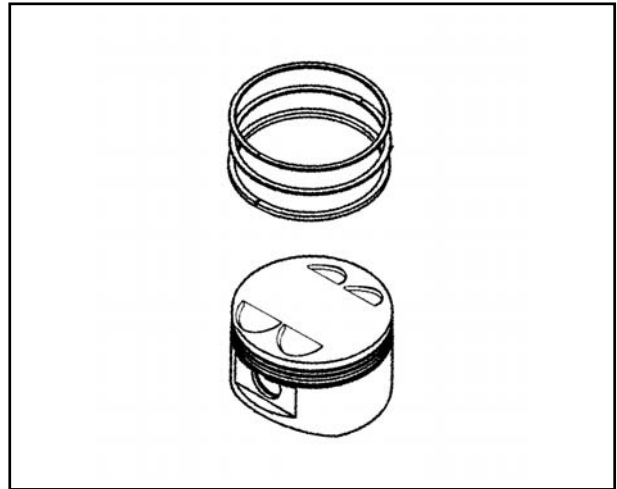

INSPECTION

Piston ring

Inspect the piston rings for movement by rotating the rings. The rings should be able to move in their grooves without catching.

Push the ring until the outer surface of the piston ring is nearly flush with the piston and measure the ring-to-groove clearance.

Service Limits:

Top: 0.08 mm (0.003 in)

2nd: 0.065 mm (0.0026 in)

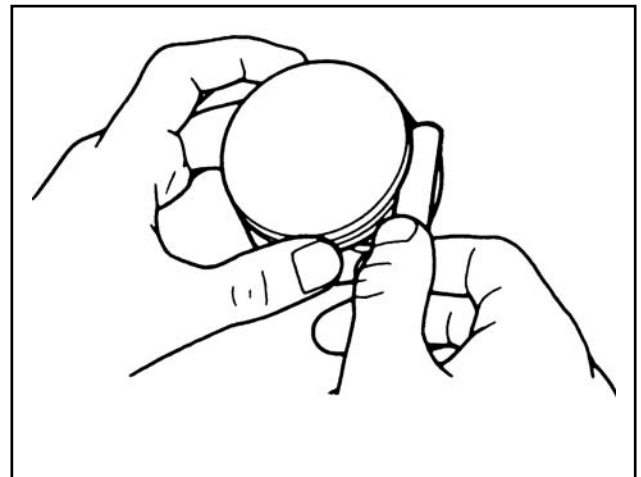

Insert each piston ring into the bottom of the cylinder squarely.

* Use the piston head to push each piston ring into the cylinder.

Measure the piston ring end gap.

Service Limit:

Top: 0.5 mm (0.02 in)

2nd: 0.65 mm (0.026 in)

Oil ring: 1 mm (0.04 in)

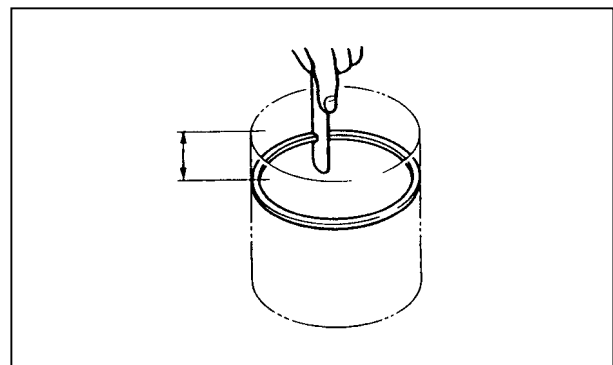

9. CYLINDER/PISTON

Piston/Piston pin

Measure the piston O.D. at the point (A) from the bottom and 90° to the piston pin hole.

Service Limit:

91.9 mm (3.676 in) at (A): 10 mm

Calculate the cylinder-to-piston clearance.

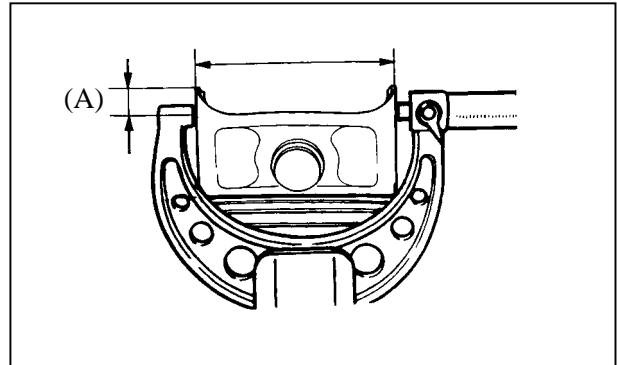

Measure the piston pin hole. Take the maximum reading to determine the I.D.

Service Limit: 22.04 mm (0.8816 in)

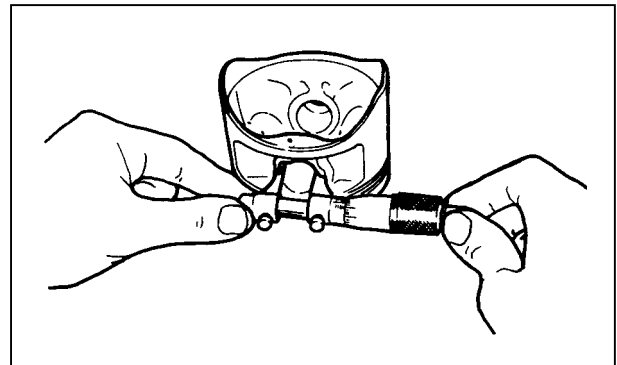

Measure the piston pin O.D at piston and connecting rod sliding areas.

Service Limit: 21.96 mm (0.8784 in)

Measure the piston-to-piston pin clearance.

Service Limit: 0.02 mm (0.001 in)

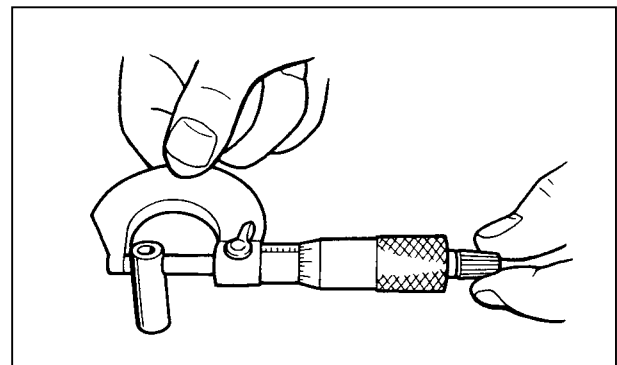

9. CYLINDER/PISTON

Cylinder

Check the cylinder for warpage with a straight edge and feeler gauge in the directions shown.

Service Limit: 0.05 mm (0.002 in)

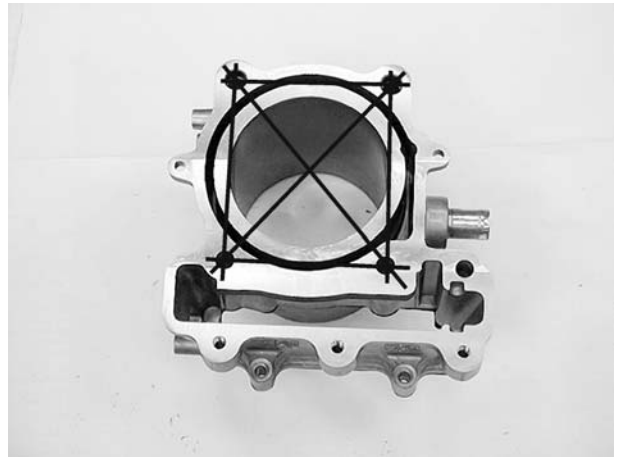

Check the cylinder wall for wear or damage. Measure and record the cylinder I.D. at three levels in an X and Y axis. Take the maximum reading to determine the cylinder wear.

Service Limit: 92.1 mm (3.684 in)

Calculate the piston-to-cylinder clearance. Take a maximum reading to determine the clearance.

Service Limit: 0.1 mm (0.004 in)

Calculate the taper and out-of-round at three levels in an X and Y axis. Take the maximum reading to determine them.

Service Limit:

Taper: 0.1 mm (0.004 in)

Out-of-round: 0.1 mm (0.004 in)

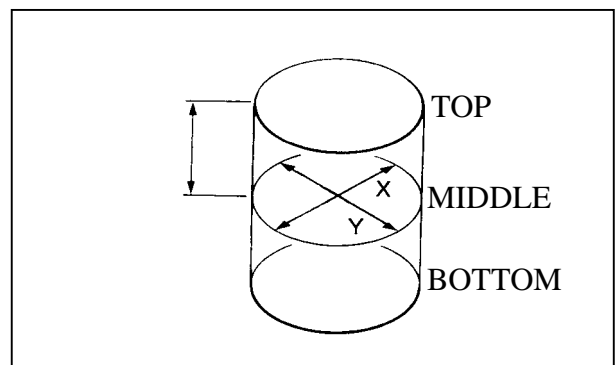

9. CYLINDER/PISTON

Measure the connecting rod small end I.D.

Service Limit: 22.06 mm (0.8824 in)

Calculate the connecting rod-to-piston pin clearance.

Service Limit: 0.06 mm (0.002 in)

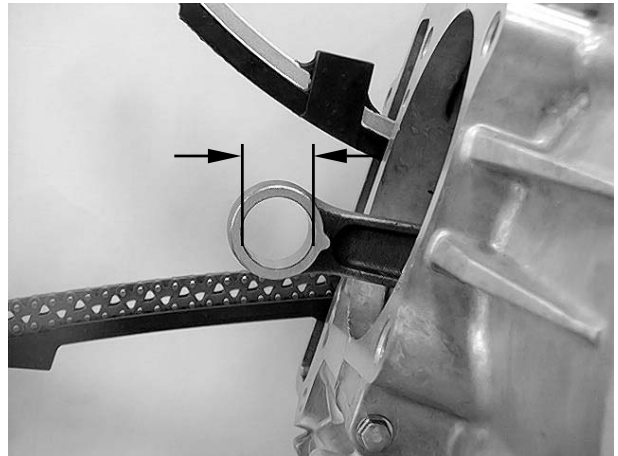

INSTALLATION

Piston ring

Carefully install the piston rings into the piston ring grooves with the markings facing up.

* Be careful not to damage the piston and rings.

- ◆ Do not confuse the top and second rings.
- ◆ To install the oil ring, install the oil ring, then install the side rails.

Stagger the piston ring end gaps 120° degrees apart from each other.

Stagger the side rail end gaps as shown.

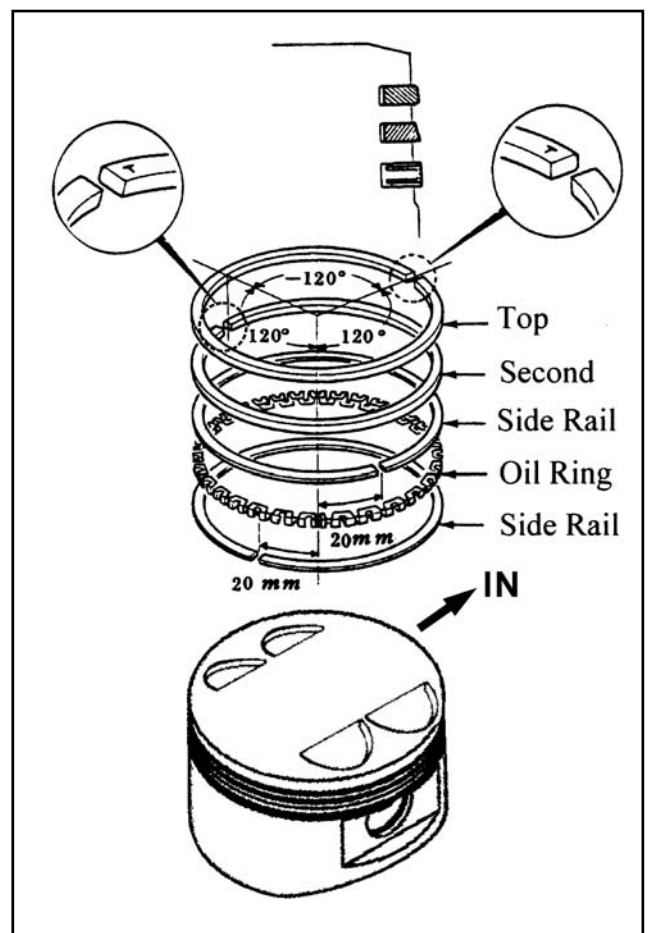

9. CYLINDER/PISTON

Cylinder/Piston

Clean any gasket material from the cylinder mating surfaces of the crankcase and oil passage.

Apply engine oil to the piston pin.

Apply engine oil to the connecting rod small end and piston pin hole.

Install the piston with the “IN” mark face intake side and piston pin.

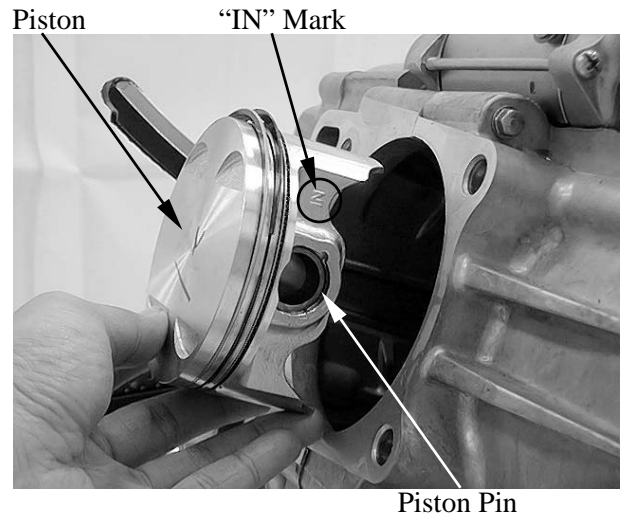

Place a clean shop towel over the crankcase prevent the clip from falling into the crankcase.

Install the new pin clip.

- * ♦Make sure that the piston pin clips are seated securely.
♦Do not align the piston pin clip end gap with the piston cut-out.

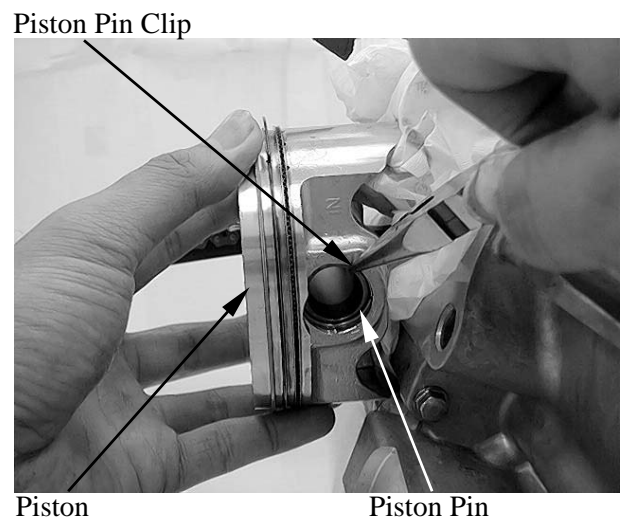

Install the dowel pins and gasket.

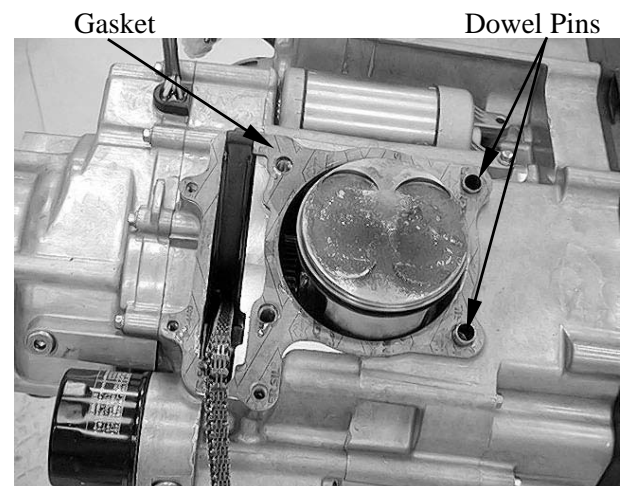

9. CYLINDER/PISTON

Apply engine oil to the cylinder wall, piston and piston ring outer surfaces.

Pass the cam chain through the cylinder and install the cylinder over the piston.

* Be careful not to damage the piston rings and cylinder walls.

Install the two cylinder bolts/washers and after the cylinder head and holders has installed (refer to the “**CYLINDER HEAD REMOVAL/INSTALLATION**” section in the chapter 8), then tighten the two cylinder bolts to specified torque.

Torque: 10 N•m (1 kgf•m, 7 lbf•ft)

Install the block pin.

Connect the water hose.

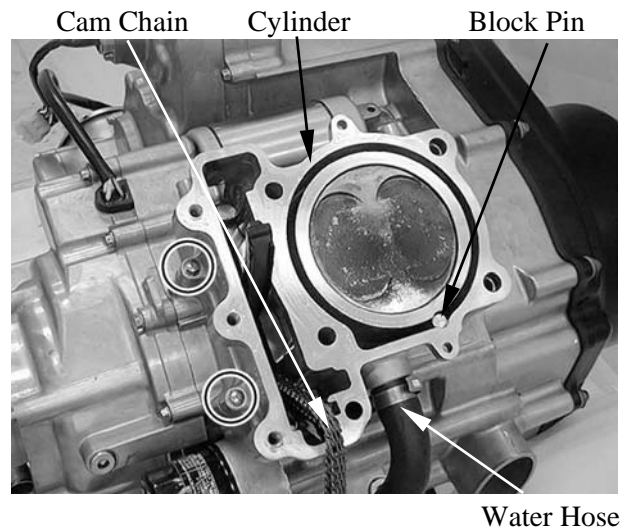

DRIVE PULLEY/DRIVEN PULLEY/CLUTCH

SCHEMATIC DRAWING -----	10- 1
SERVICE INFORMATION-----	10- 2
TROUBLESHOOTING-----	10- 2
LEFT CRANKCASE COVER REMOVAL/INSTALLATION -----	10- 3
DRIVE PULLEY, DRIVE V-BELT AND DRIVEN PULLEY REMOVAL/INSPECTION/ INSTALLATION -----	10- 5
DRIVE PULLEY DISASSEMBLY/INSPECTION/ASSEMBLY ----	10- 9
DRIVEN PULLEY DISASSEMBLY/INSPECTION/ASSEMBLY --	10-13
CLUTCH REMOVAL/INSTALLATION-----	10-17
CLUTCH DISASSEMBLY/INSPECTION/ASSEMBLY -----	10-21

10. DRIVE PULLEY/DRIVEN PULLEY/CLUTCH MXU550EXi/MXU500i

SCHEMATIC DRAWING

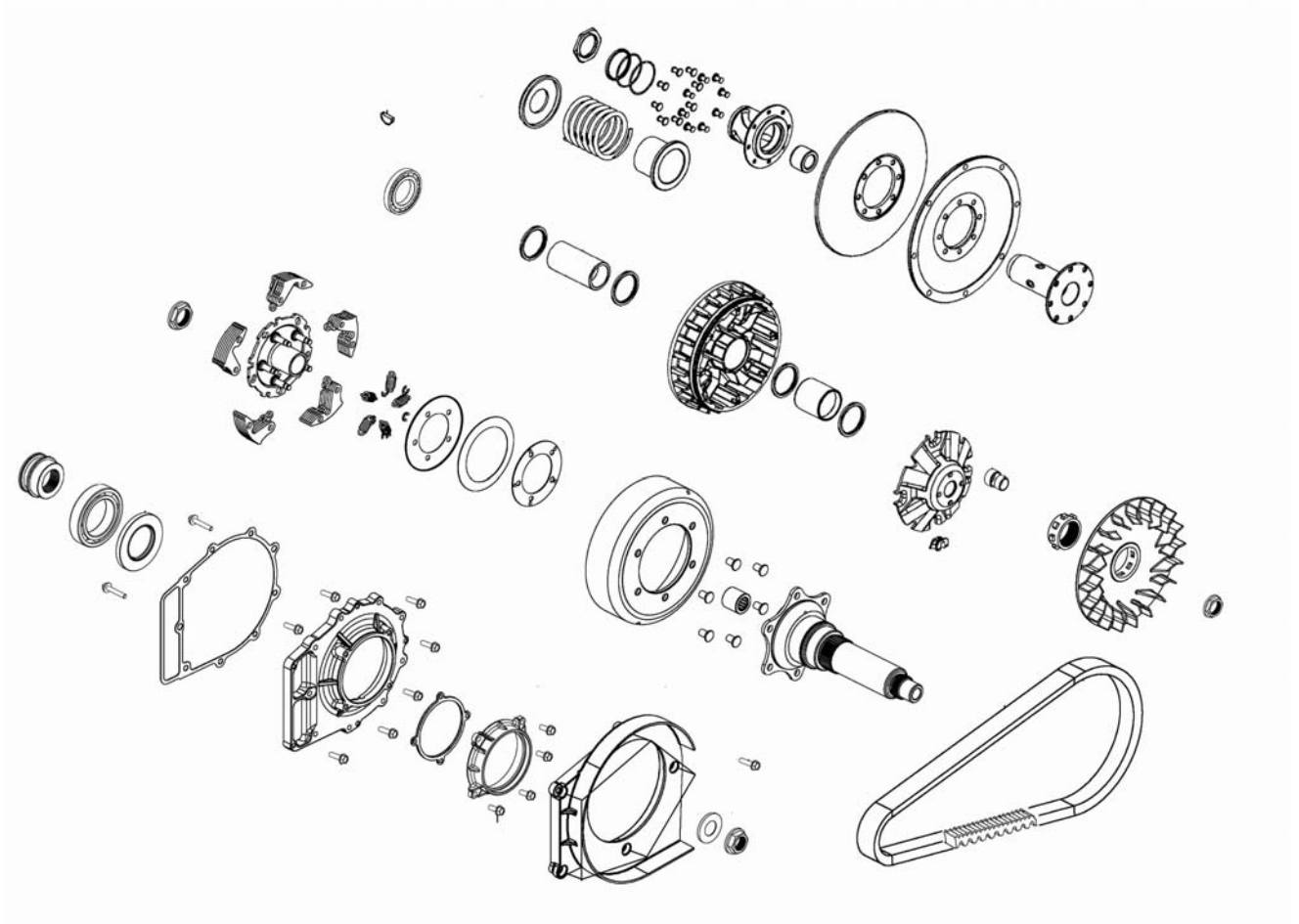

10. DRIVE PULLEY/DRIVEN PULLEY/CLUTCH MXU550EXi/MXU500i

SERVICE INFORMATION

GENERAL INSTRUCTIONS

- The drive pulley, clutch and driven pulley can be serviced with the engine installed.
- Avoid getting grease and oil on the drive belt and pulley faces. Remove any oil or grease from them to minimize the slipping of drive belt and drive pulley.
- Do not apply grease to the movable drive face and weight rollers.

SPECIFICATIONS

Unit: mm (in)

Item	Standard	Service Limit
Drive belt width	34.1 (1.364)	30.8 (1.232)
Clutch shoe thickness	1.5 (0.06)	1 (0.04)
Driven pulley spring	124.3 (4.972)	121.3 (4.852)
Weight roller O.D.	29.9 (1.196)~30.1 (1.204)	29.5 (1.18)

TORQUE VALUES

Drive pulley nut	14 kgf-m (140 N-m, 100.8 lbf-ft)	Apply oil to the threads
Clutch nut	14 kgf-m (140 N-m, 100.8 lbf-ft)	
Driven pulley nut	10 kgf-m (100 N-m, 72 lbf-ft)	Apply oil to the threads
Driven pulley assembly plate nut	7.5 kgf-m (75 N-m, 54 lbf-ft)	

SPECIAL TOOLS

Oil seal & bearing install	A120E00014
Bearing puller	A120E00037
Y-type holder	A120E00056
Drive pulley holder	A120E00058
Driven pulley spring compressor	A120E00059
Lock nut wrench	A120E00079

TROUBLESHOOTING

Engine starts but ATV won't move

- Worn drive belt
- Broken ramp plate
- Worn or damaged clutch lining
- Broken driven face spring

Engine stalls or ATV creeps

- Broken clutch weight spring

Lack of power

- Worn drive belt
- Weak driven face spring
- Worn weight roller
- Faulty driven face

10. DRIVE PULLEY/DRIVEN PULLEY/CLUTCH MXU550EXi/MXU500i

LEFT CRANKCASE COVER REMOVAL/INSTALLATION

REMOVAL

Remove the left footboard (refer to the “**FRAME COVERS**” section in the chapter 2).

Remove the ten bolts, remove the left crankcase cover and rubber gasket.

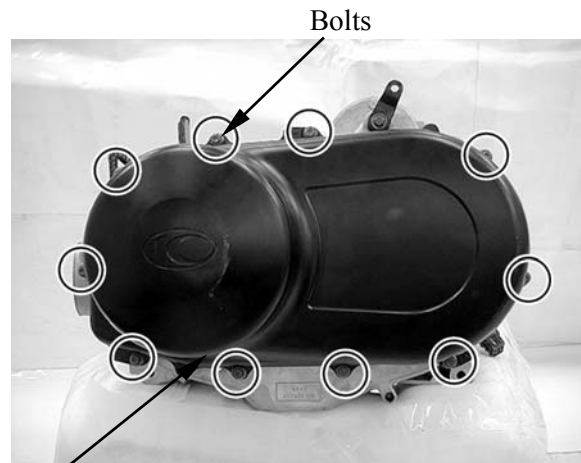

Left Front Cover

Remove the two dowel pins.

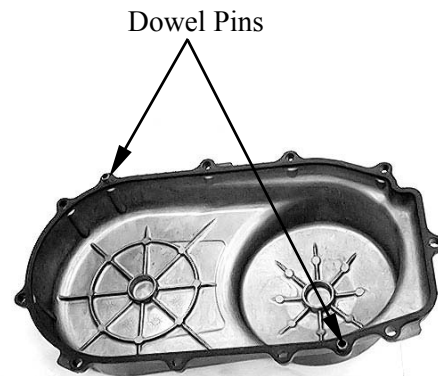

INSTALLATION

Install the rubber gasket onto the left crankcase cover.

Install the two dowel pins onto the left crankcase cover.

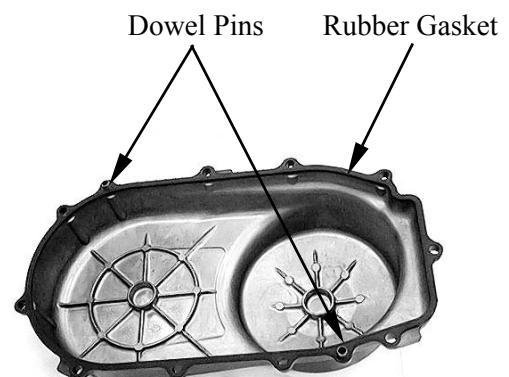

10. DRIVE PULLEY/DRIVEN PULLEY/CLUTCH MXU550EXi/MXU500i

Install the left crankcase cover and tighten the ten bolts diagonally to specified torque.

Torque: 1 kgf-m (10 N-m, 7.2 lbf-ft)

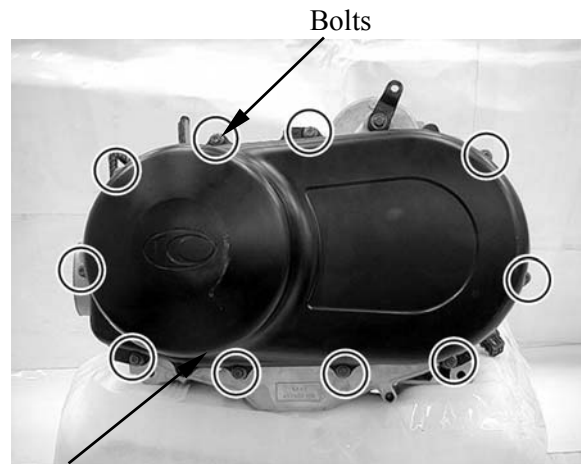

Left Front Cover

10. DRIVE PULLEY/DRIVEN PULLEY/CLUTCH MXU550EXi/MXU500i

DRIVE PULLEY, DRIVE V-BELT AND DRIVEN PULLEY REMOVAL/INSPECTION/INSTALLATION

REMOVAL

Use the special tool to hold the drive pulley, then remove the nut and washer.

Special tool:

Drive pulley holder A120E00058

Remove the drive pulley.

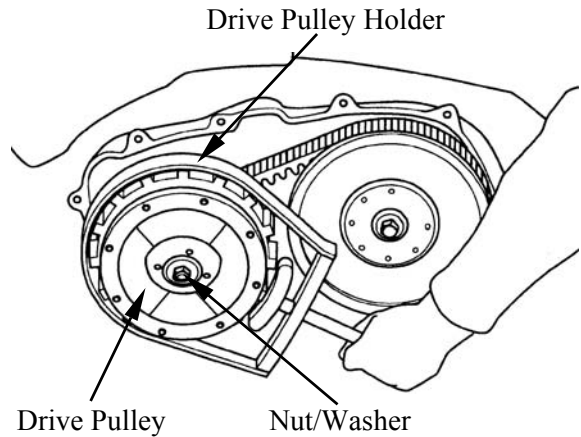

Use the special tool to hold the driven pulley, then remove the nut.

Special tool:

Y-type holder A120E00056

Remove the driven pulley and V-belt.

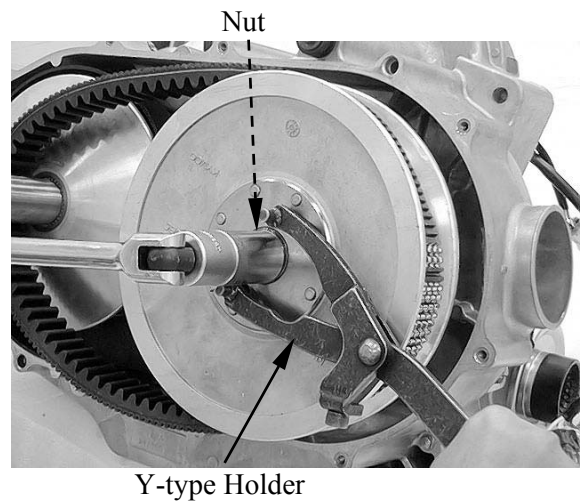

Remove the driven pulley washer.
Remove the drive pulley face.

* Do not loosen the stopper lever shaft nut, it may cause stopper lever bolt loosen. To tighten the stopper lever bolt must remove the crankcase (refer to the "TRANSMISSION REMOVAL/INSPECTION/INSTALLATION" section in the chapter 11).

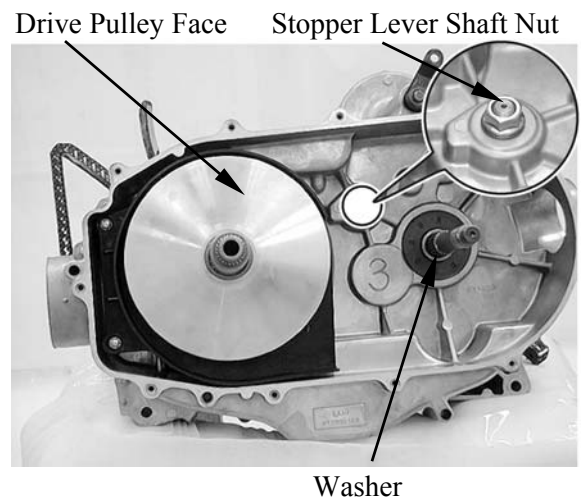

10. DRIVE PULLEY/DRIVEN PULLEY/CLUTCH MXU550EXi/MXU500i

Remove the five bolts and then remove the fan guide.

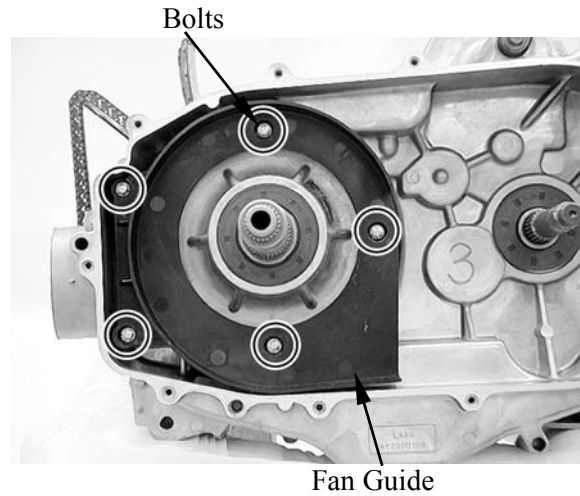

INSPECTION

Inspect the drive belt for cracks, scaling, chipping or excessive wear.
Measure the V-belt width

Service limit (A): 30.8 mm (1.232 in)

Replace the drive belt if out of specification.

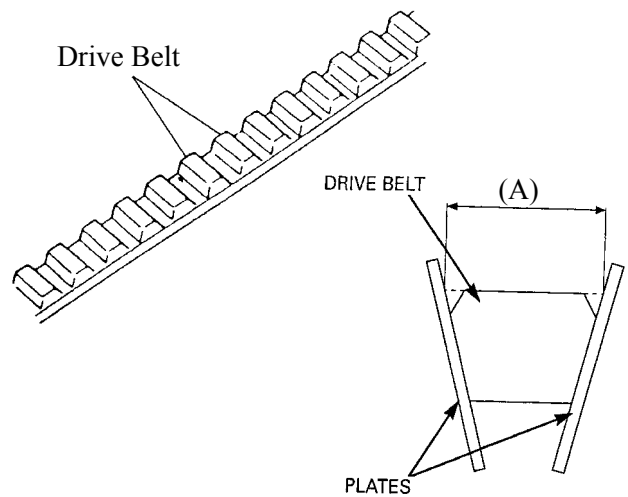

INSTALLATION

Install the fan guide.
Install the drive pulley face.
Install the driven pulley washer.

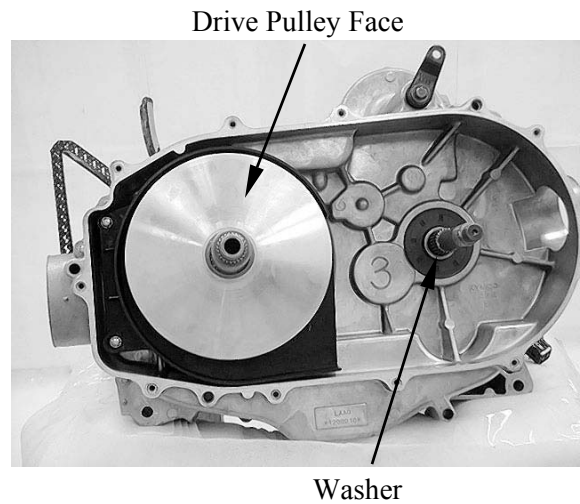

10. DRIVE PULLEY/DRIVEN PULLEY/CLUTCH MXU550EXi/MXU500i

Place a block on the plate nut.

Compress the spring by using a commercially available puller, install the drive belt.

- *
- The drive belt should be installed so that the arrows on the drive belt periphery point in the normal turning direction.
 - The drive belt contact surface of the driven face should be thoroughly cleaned.

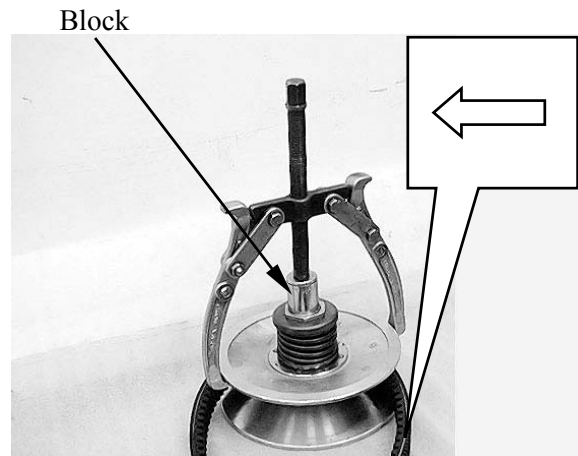

Install the driven pulley assembly and drive V-belt.

Use the special tool to hold driven pulley, then tighten the nut to the specified torque.

Torque: 10 kgf-m (100 N-m, 72 lbf-ft)

Apply oil to the threads

Special tools:

Y-type holder A120E00056

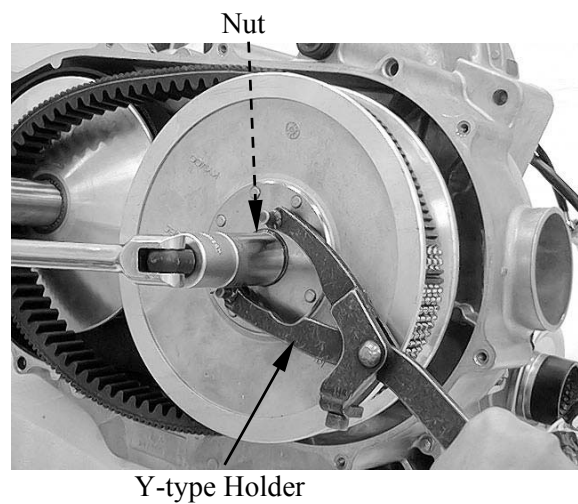

Apply lubricant to the drive face boss inner surface, then install the drive pulley.

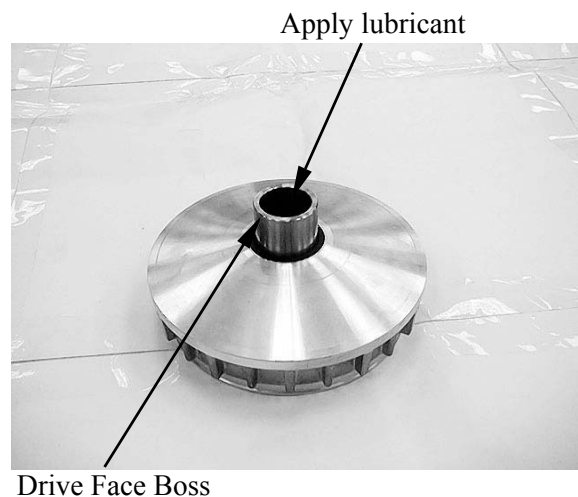

10. DRIVE PULLEY/DRIVEN PULLEY/CLUTCH MXU550EXi/MXU500i

Install the drive pulley assembly.
Install the washer and nut.

* Make sure the "OUT SIDE" marks on the washer faces the left crankcase cover.

Use the special tool to hold drive pulley, then tighten the nut to the specified torque.

Torque: 14 kgf-m (140 N-m, 100.8 lbf-ft)
Apply oil to the threads

Special tool:

Drive pulley holder A120E00058

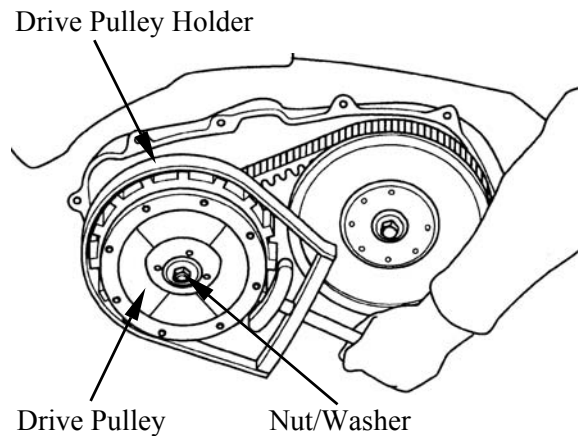

10. DRIVE PULLEY/DRIVEN PULLEY/CLUTCH MXU550EXi/MXU500i

DRIVE PULLEY DISASSEMBLY/INSPECTION/ ASSEMBLY

DISASSEMBLY

Remove the drive pulley (refer to “**DRIVE PULLEY AND DRIVEN PULLEY REMOVAL/INSTALLATION**” section)

Remove the drive face boss.

Drive Face Boss

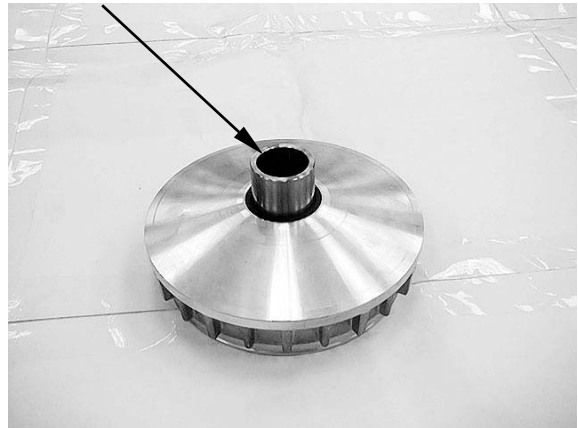

Remove the ramp plate and four slide pieces.

Ramp Plate Slide Pieces

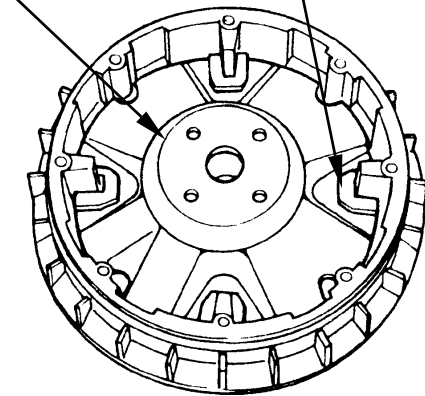

Remove the eight weight rollers.

Weight Rollers

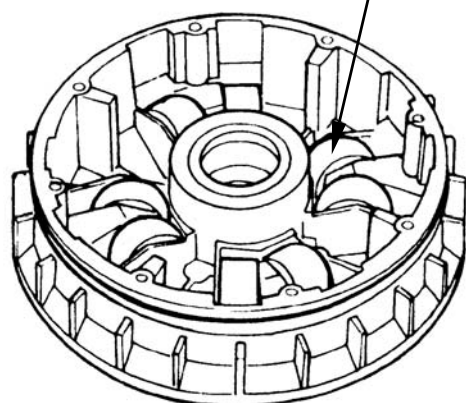

10. DRIVE PULLEY/DRIVEN PULLEY/CLUTCH MXU550EXi/MXU500i

INSPECTION

Weight rollers

Check each roller for wear or damage.
Measure outside diameter.

Service limit: 29.5 mm (1.18 in)

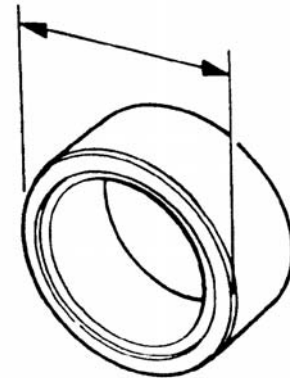

Movable drive face/Slide pieces/Drive pulley face

Check the slide pieces and movable drive face splines for wear, cracks or damage.

Check the ramp plate for cracks or damage.

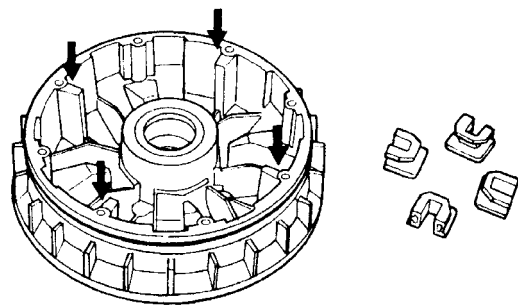

Check the movable drive face and drive pulley face cracks or damage.

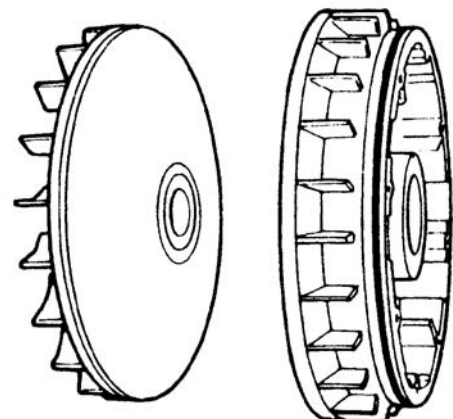

10. DRIVE PULLEY/DRIVEN PULLEY/CLUTCH MXU550EXi/MXU500i

Check the dust seals on the movable drive face for wear or damage.

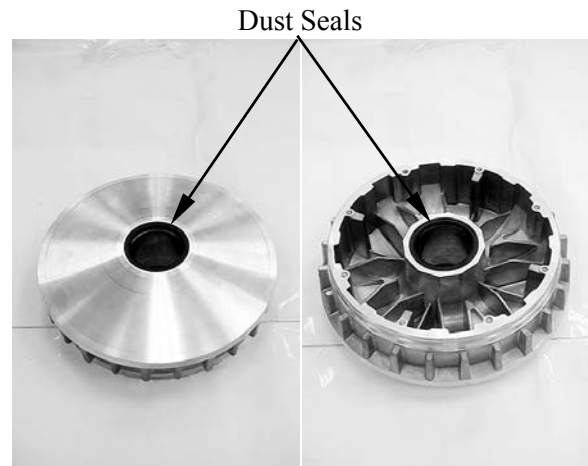

ASSEMBLY

Clean the movable drive face, drive pulley face, weight rollers, slide pieces, ramp plate and drive face boss.

* Remove any excess grease.

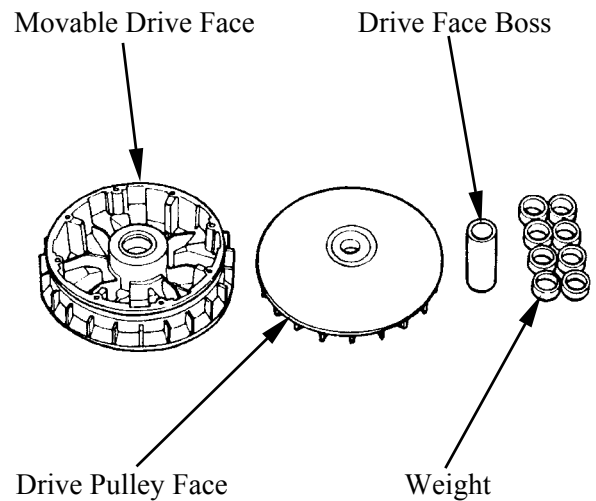

Install the weight rollers.

* The direction of all weight rollers is the same. The thin side is towards to counterclockwise.

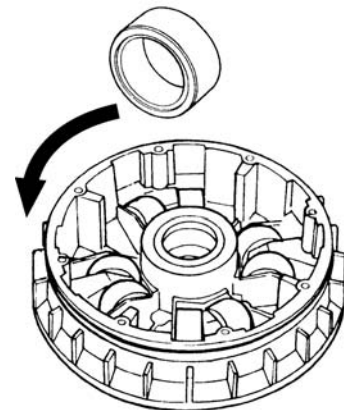

10. DRIVE PULLEY/DRIVEN PULLEY/CLUTCH MXU550EXi/MXU500i

Install the slide pieces and ramp plate.

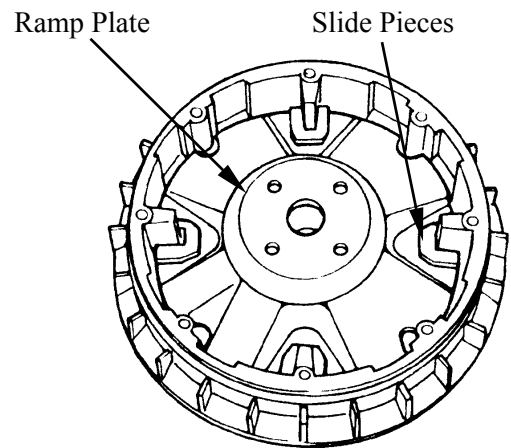

Install the drive face boss.



DRIVEN PULLEY DISASSEMBLY/INSPECTION/ ASSEMBLY

DISASSEMBLY

Remove the driven pulley (refer to the “**DRIVE PULLEY AND DRIVEN PULLEY REMOVAL/INSTALLATION**” section in this chapter).

Use the special tool to remove the nut.

Special tool:

Driven pulley spring compressor

A120E00059

- *
- Install the block and bolts, then tighten the bolts.
 - Attach the block, nut wrench and spring compressor to the driven pulley assembly.
 - Place the block in a vise and secure it.
 - Tighten the spring compressor nut and compress the spring.
 - Loosen the nut with the nut wrench.
 - Remove the nut.
 - Remove the spring compressor and nut wrench.

Remove the spring seat on the spring and spring.

Remove the spring collar on the movable driven face.

Remove the four guide pins/rollers, then remove the movable driven face.

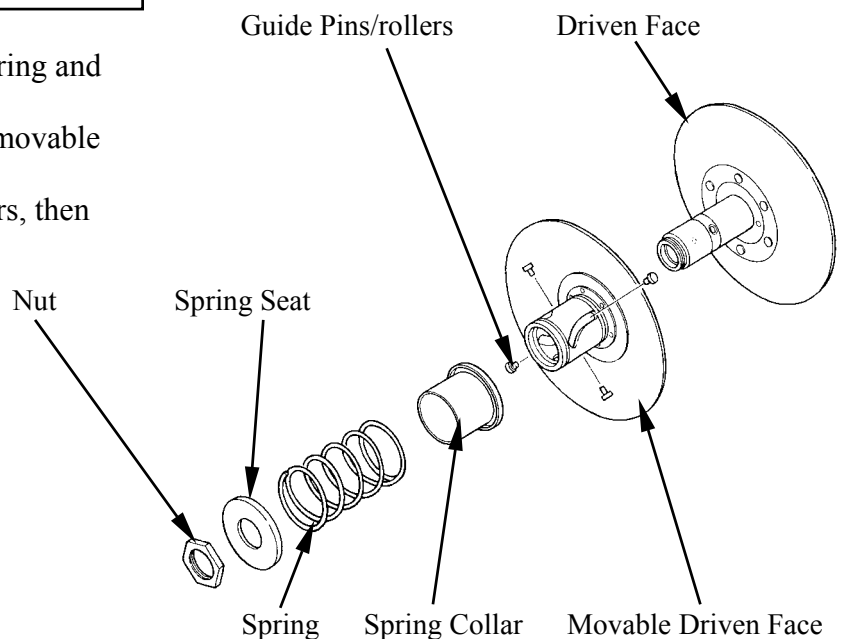
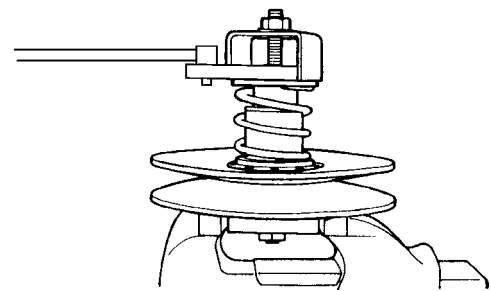
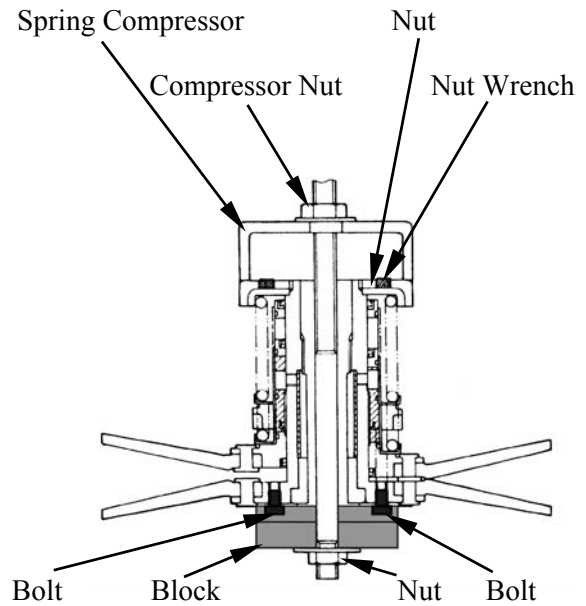

10. DRIVE PULLEY/DRIVEN PULLEY/CLUTCH MXU550EXi/MXU500i

Remove the O-rings and dust seals from the movable driven face.

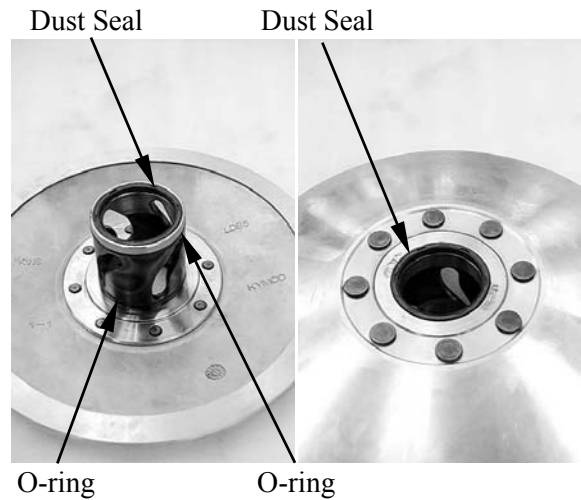

INSPECTION

Check the driven pulley for smooth operation.

If any scratches or damage is found then replace as a set.

Check the torque cam grooves for wear or damage.

Check guide pins and rollers for wear or damage.

If any scratches or damage is found then replace as a set.

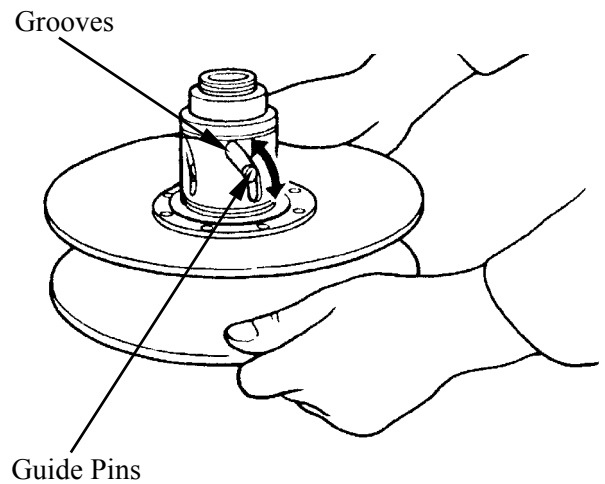

Check the spring for damage.
Measure the spring free length.

Service limit: 121.3 mm (4.852 in)

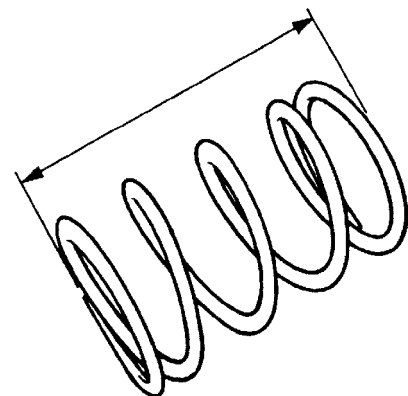

10. DRIVE PULLEY/DRIVEN PULLEY/CLUTCH MXU550EXi/MXU500i

ASSEMBLY

Clean any oil from the drive belt sliding surfaces on the driven face.

Apply grease to lips of the new dust seals and install into the movable driven face.

Coat new O-rings with grease and install them into the movable driven face grooves.

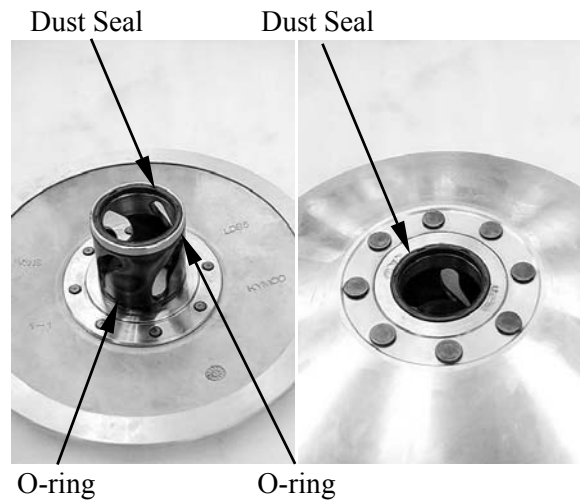

Install the movable driven face onto the driven face.

Install the guide rollers and guide roller pins.

Filling 8 g of grease to each guide groove.

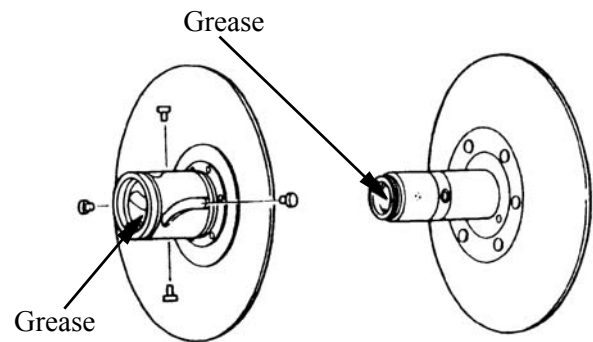

Install the guide pins/rollers.

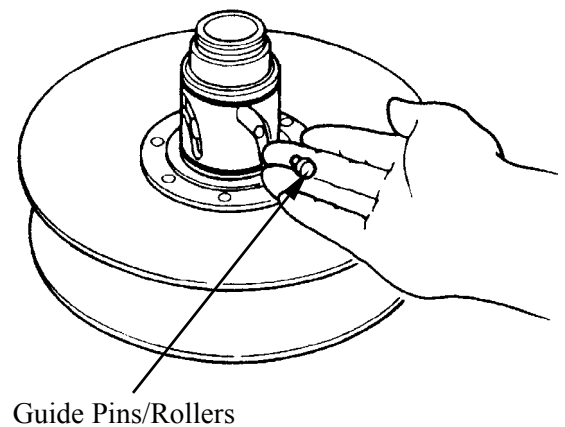

10. DRIVE PULLEY/DRIVEN PULLEY/CLUTCH MXU550EXi/MXU500i

Install spring collar.

Use the special tool to install spring and spring seat, then install and tighten the nut to the specified torque.

Torque: 7.5 kgf-m (75 N-m, 54 lbf-ft)

Special tool:

Driven pulley spring compressor

A120E00059

- *
 - Attach the block, nut, nut wrench and spring compressor to the driven pulley assembly.
 - Place the block in a vise and secure it.
 - Tighten the spring compressor nut and compress the spring.
 - Install the nut and tighten it to the specified torque with the nut wrench.
 - Remove the spring compressor and nut wrench.

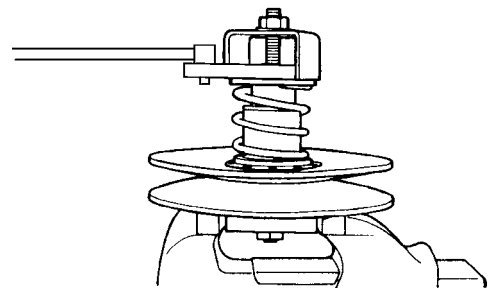
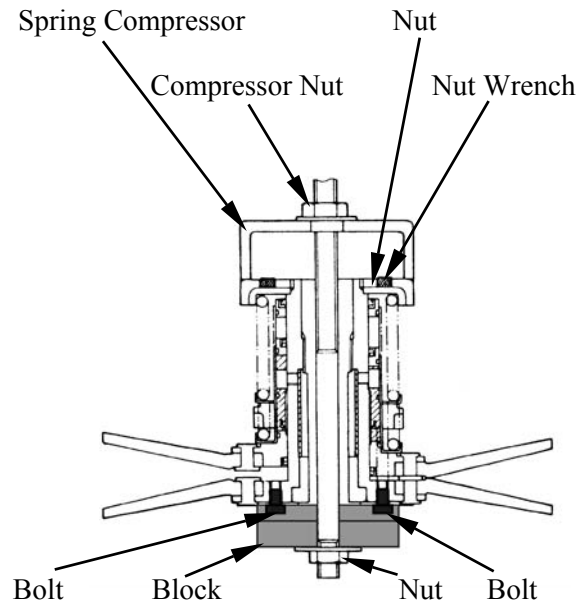

CLUTCH REMOVAL/INSTALLATION

REMOVAL

Remove the fan guide (refer to the “**DRIVE PULLEY AND DRIVEN PULLEY REMOVAL/INSTALLATION**” section in this chapter).

Remove the nine bolts and then remove the clutch housing assembly and one-way clutch bearing.

* Working in crisscross pattern, loosen each bolt 1/4 of a turn. Remove them after all of them are loosened.

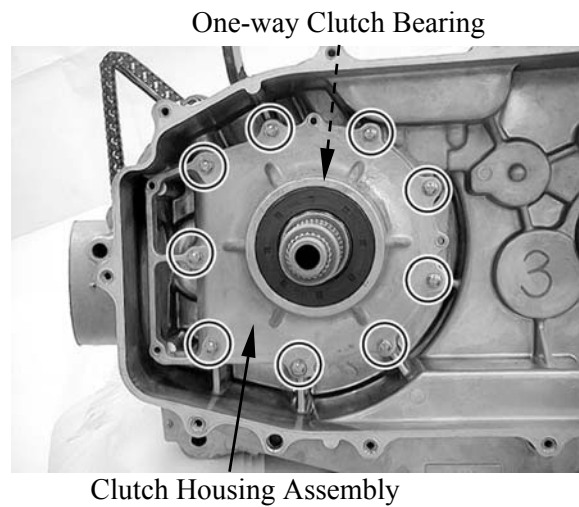

Remove the two dowel pins and gasket.

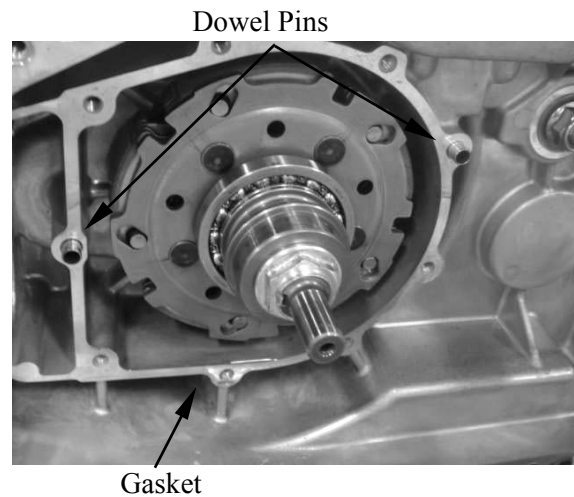

Using a chisel, unlock the nut.

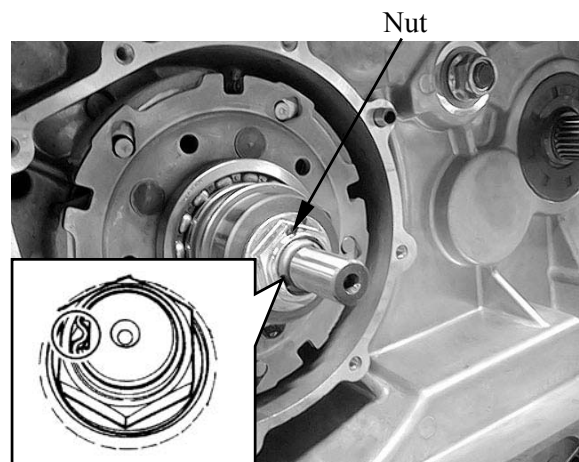

10. DRIVE PULLEY/DRIVEN PULLEY/CLUTCH MXU550EXi/MXU500i

Use the special tool to hold clutch carrier assembly.

Special tool:

Y-type holder A120E00056

Not USA type:

Use the special tool to remove the nut and washer.

Special tool:

Lock nut wrench A120E00079

USA type:

Remove the nut and collar.

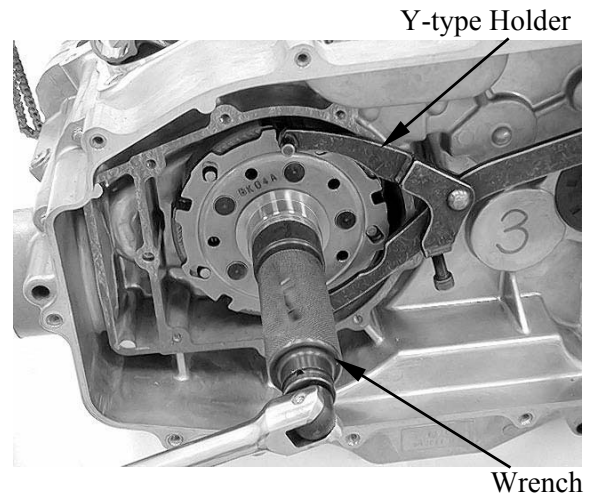

Remove the clutch carrier assembly and collar.

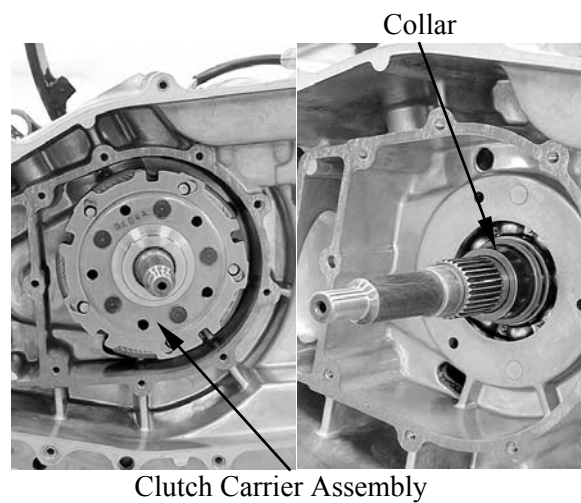

10. DRIVE PULLEY/DRIVEN PULLEY/CLUTCH MXU550EXi/MXU500i

INSTALLATION

Apply clean engine oil to the clutch carrier assembly and collar, then install the collar and clutch carrier assembly.

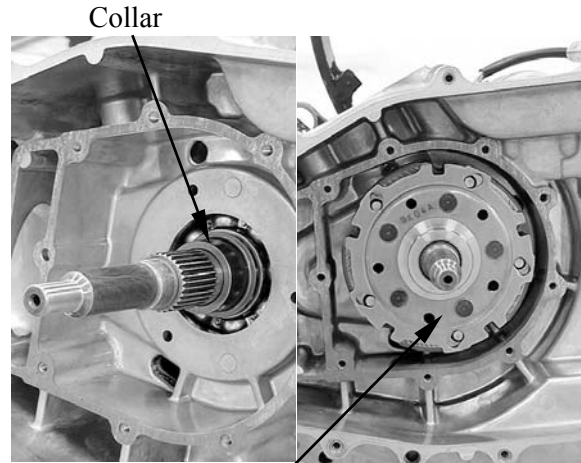

Clutch Carrier Assembly

Install the washer

Install the collar

Use the special tools to install and tighten the nut to the specified torque.

Torque: 14 kgf-m (140 N-m, 100.8 lbf-ft)

Special tool:

Y-type holder A120E00056

Lock nut wrench A120F00079

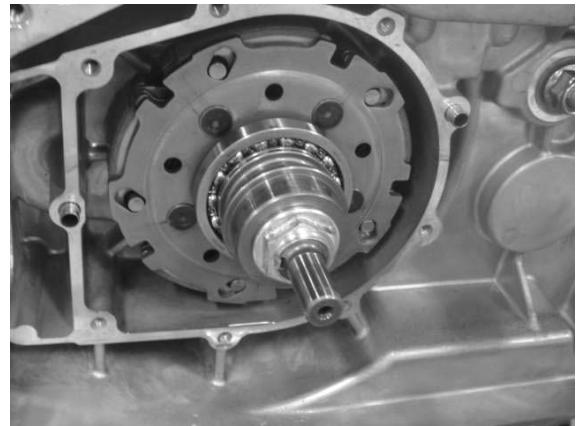

Stake the nut with a center punch.

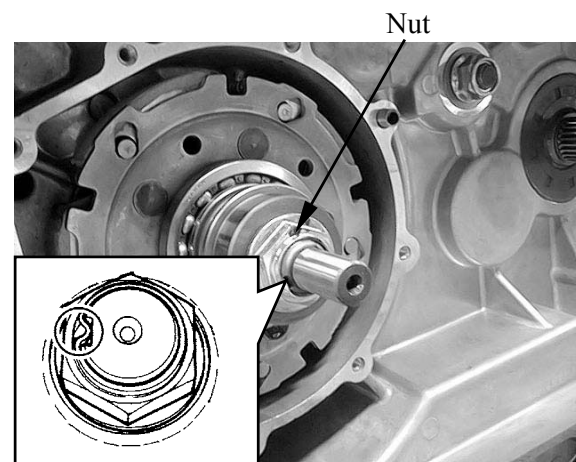

10. DRIVE PULLEY/DRIVEN PULLEY/CLUTCH MXU550EXi/MXU500i

Install the dowel pins and gasket.

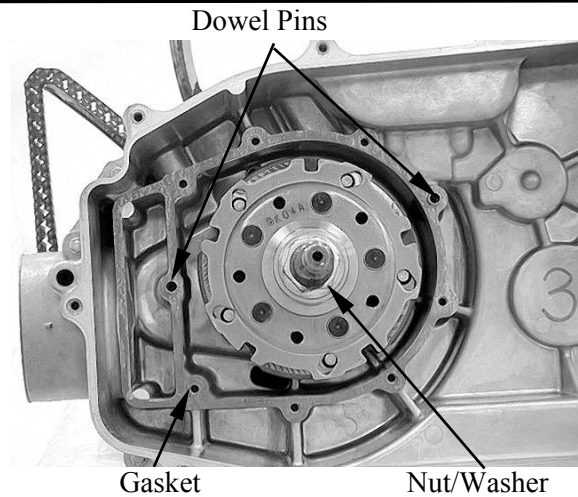

Apply molybdenum disulfide grease to the one-way clutch bearing, then install it. Install the clutch housing and tighten the bolts to the specified torque in a crisscross pattern in 2-3 steps.

Torque: 1 kgf-m (10 N-m, 7.2 lbf-ft)

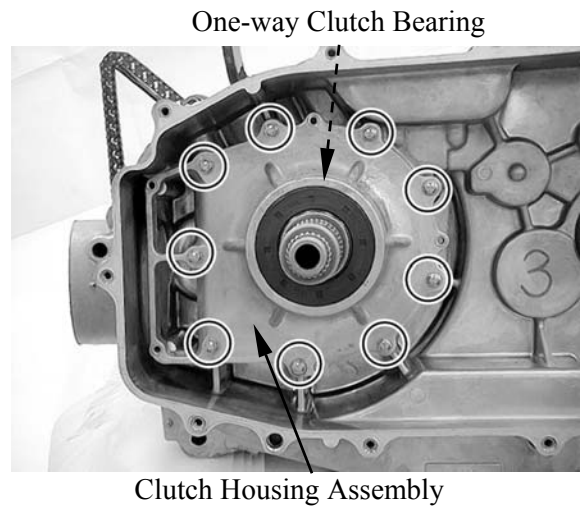

10. DRIVE PULLEY/DRIVEN PULLEY/CLUTCH MXU550EXi/MXU500i

CLUTCH DISASSEMBLY/INSPECTION/ ASSEMBLY

DISASSEMBLY

Remove the clutch housing and clutch carrier assembly (refer to the “**CLUTCH REMOVAL/INSTALLATION**” section in this chapter).

Remove the one-way clutch bearing from the clutch housing.

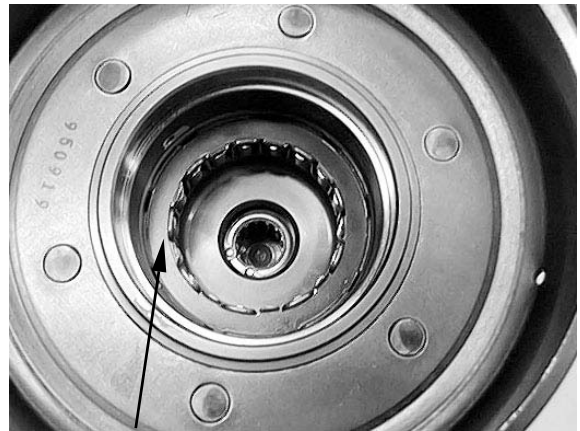

One-way Clutch Bearing

Clutch housing removal (not USA type):

Remove the oil seal.

Remove the snap ring, then remove the clutch housing.

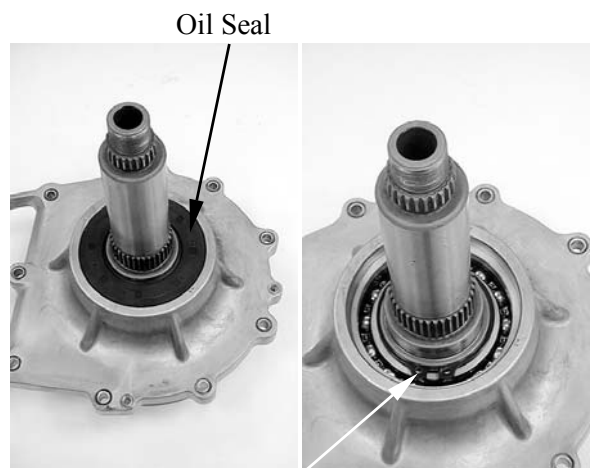

Snap Ring

Remove the snap ring, then remove the bearing.

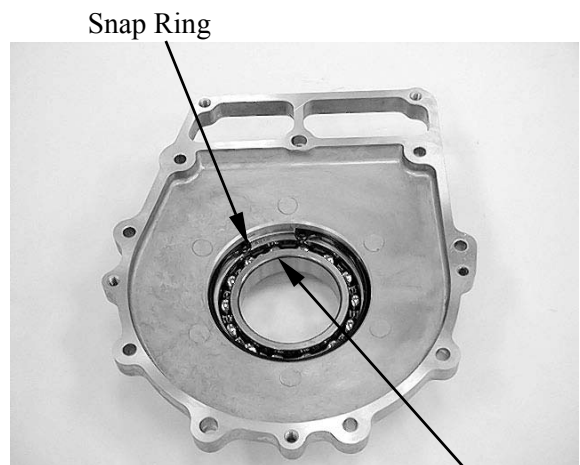

Bearing

10. DRIVE PULLEY/DRIVEN PULLEY/CLUTCH MXU550EXi/MXU500i

Clutch housing removal:

Remove the clutch housing.

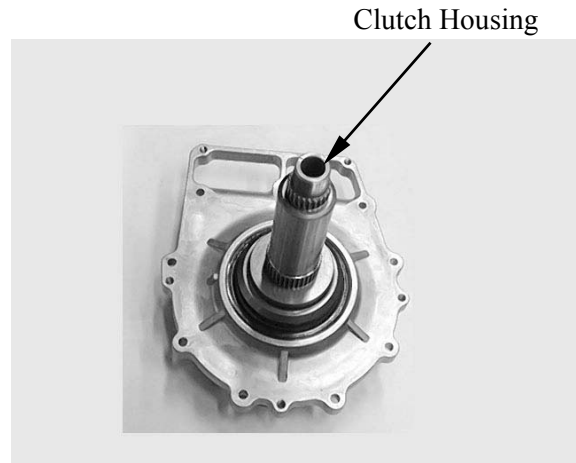

Remove the oil seal, then remove the bearing.

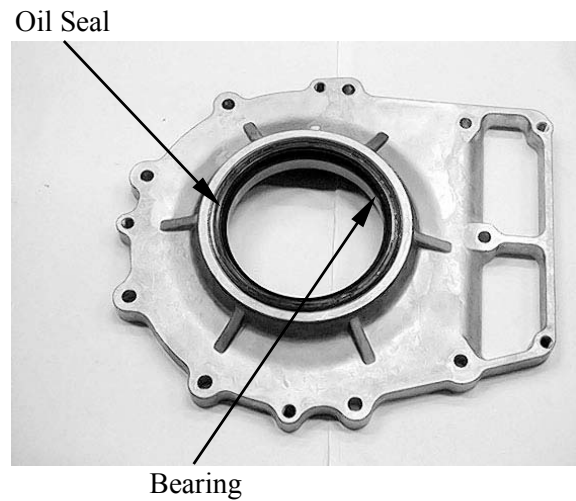

10. DRIVE PULLEY/DRIVEN PULLEY/CLUTCH MXU550EXi/MXU500i

INSPECTION

Check the clutch housing if heat damage, wear or damage.

Check the one-way clutch bearing for chafing, wear or damage.

* Replace the one-way clutch assembly and clutch housing as a set.

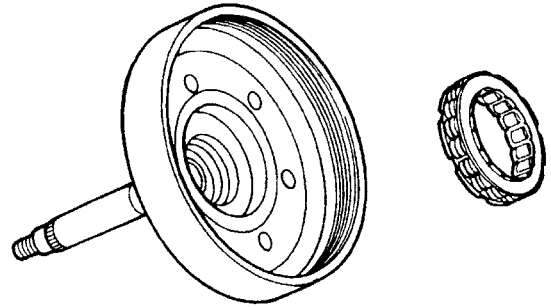

Check the clutch shoe for heat damage.

Measure the clutch shoe thickness.

Service limit (A): 1 mm (0.04 in)

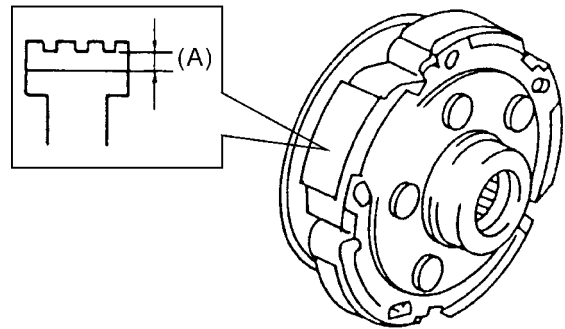

Turn the crankshaft bearing for smoothly and check for excessive play.



Bearing

10. DRIVE PULLEY/DRIVEN PULLEY/CLUTCH MXU550EXi/MXU500i

Check operation:

Install the one-way clutch bearing and clutch carrier assembly to the clutch housing and hold the clutch carrier assembly.

When turning the clutch housing clockwise, the clutch housing should turn freely. If not, the one-way clutch assembly is faulty. Replace it.

When turning the clutch housing counterclockwise, the clutch housing and crankshaft should be engaged. If not, the one-way clutch assembly is faulty. Replace it.

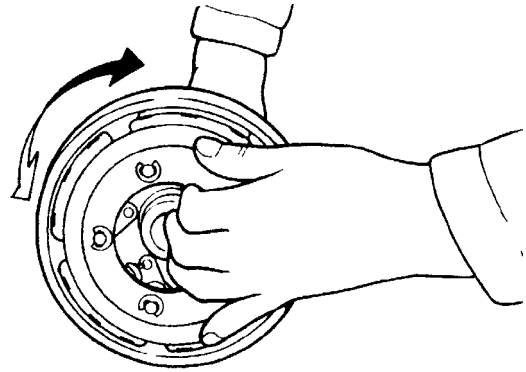

Check operation :

Install the one-way clutch bearing and collar to the clutch housing and hold the collar.

When turning the clutch housing clockwise, the clutch housing should turn freely. If not, the one-way clutch assembly is faulty. Replace it.

When turning the clutch housing counterclockwise, the clutch housing and crankshaft should be engaged. If not, the one-way clutch assembly is faulty. Replace it.

Install the clutch housing to the crankshaft.

When turning the clutch housing clockwise or counterclockwise, the clutch housing should turn smoothly. If not, the needle bearing or the clutch housing is damage, then replace the clutch housing.

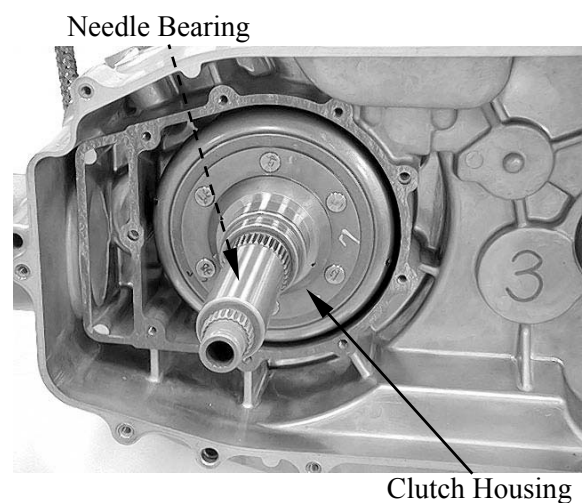

10. DRIVE PULLEY/DRIVEN PULLEY/CLUTCH MXU550EXi/MXU500i

ASSEMBLY

Clutch housing installation (not USA type):

Apply clean engine oil, then install the new bearing.
Install the snap ring.

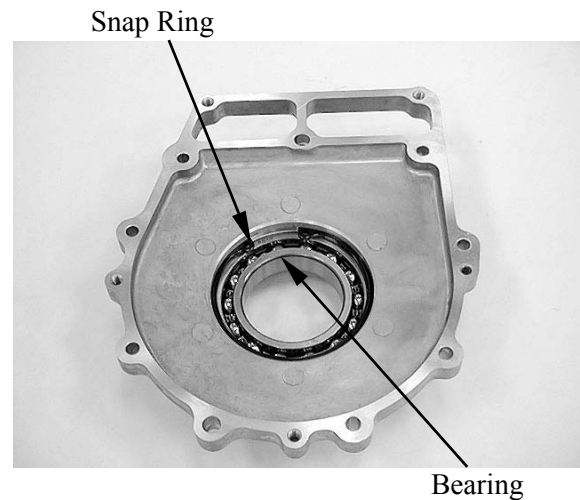

Install the clutch housing.
Install the snap ring.
Apply lightweight lithium-soap base grease to the new oil seal lip, then install the new oil seal.

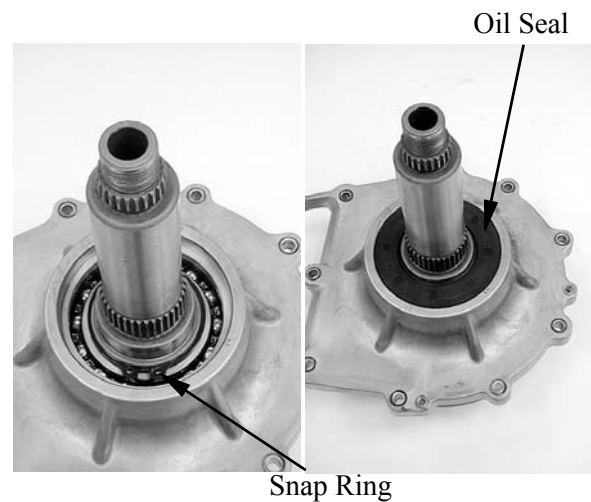

Clutch housing installation (USA type):

Apply clean engine oil, then install the new bearing.

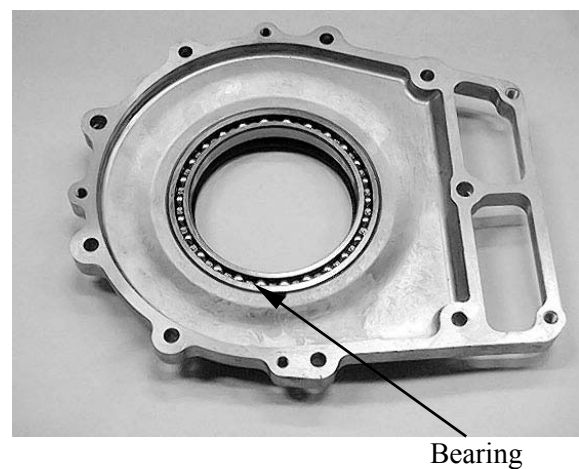

10. DRIVE PULLEY/DRIVEN PULLEY/CLUTCH MXU550EXi/MXU500i

Apply lightweight lithium-soap base grease to the new oil seal lip, then install the new oil seal.

Oil Seal

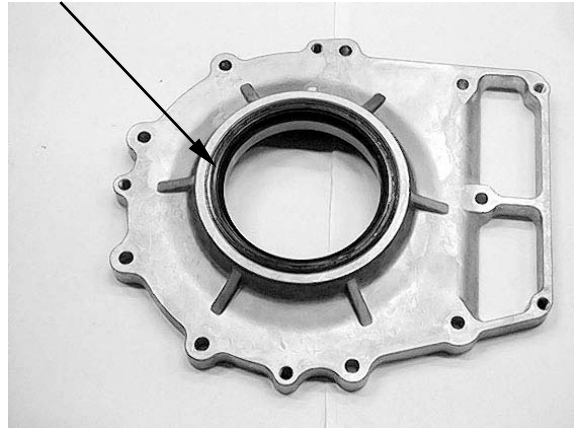

Install the clutch housing.

Clutch Housing

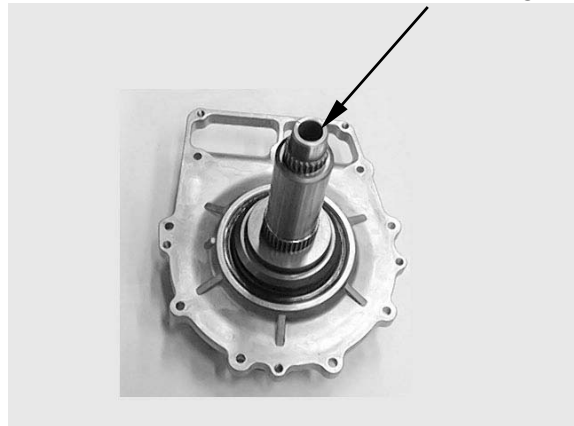

One-way clutch bearing installation:

Install the one-way clutch bearing into the clutch housing.

* The one-way clutch bearing should be installed in the clutch carrier assembly with the arrow mark and "OUT SIDE" mark facing toward the clutch carrier assembly.

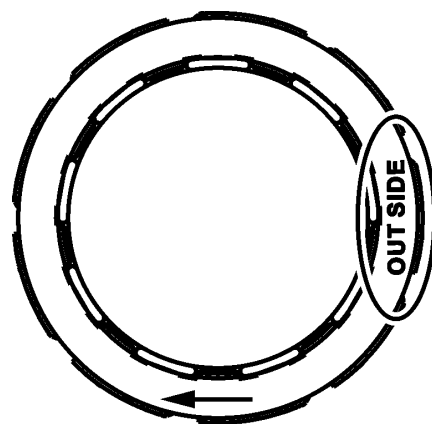

FINAL REDUCTION/TRANSMISSION SYSTEM

SERVICE INFORMATION----- 11- 2
TROUBLESHOOTING----- 11- 2
SECONDARY DRIVE/DRIVEN BEVEL GEAR
REMOVAL/INSPECTION/INSTALLATION ----- 11- 3
SECONDARY GEAR SHIMS ADJUSTMENT ----- 11- 8
RIGHT CRANKCASE REMOVAL/INSTALLATION----- 11-10
BEARING REPLACEMENT IN THE RIGHT CRANKCASE ----- 11-12
TRANSMISSION REMOVAL/INSPECTION/INSTALLATION --- 11-17
UPPER SHIFT FORK DISASSEMBLY/ASSEMBLY ----- 11-25
DRIVE SHAFT DISASSEMBLY/ASSEMBLY/INSPECTION ----- 11-26
COUNTERSHAFT DISASSEMBLY/ASSEMBLY/INSPECTION-- 11-27

11.FINAL REDUCTION/ TRANSMISSION SYSTEM

 **KYMCO**
MXU 550EXi/MXU500i

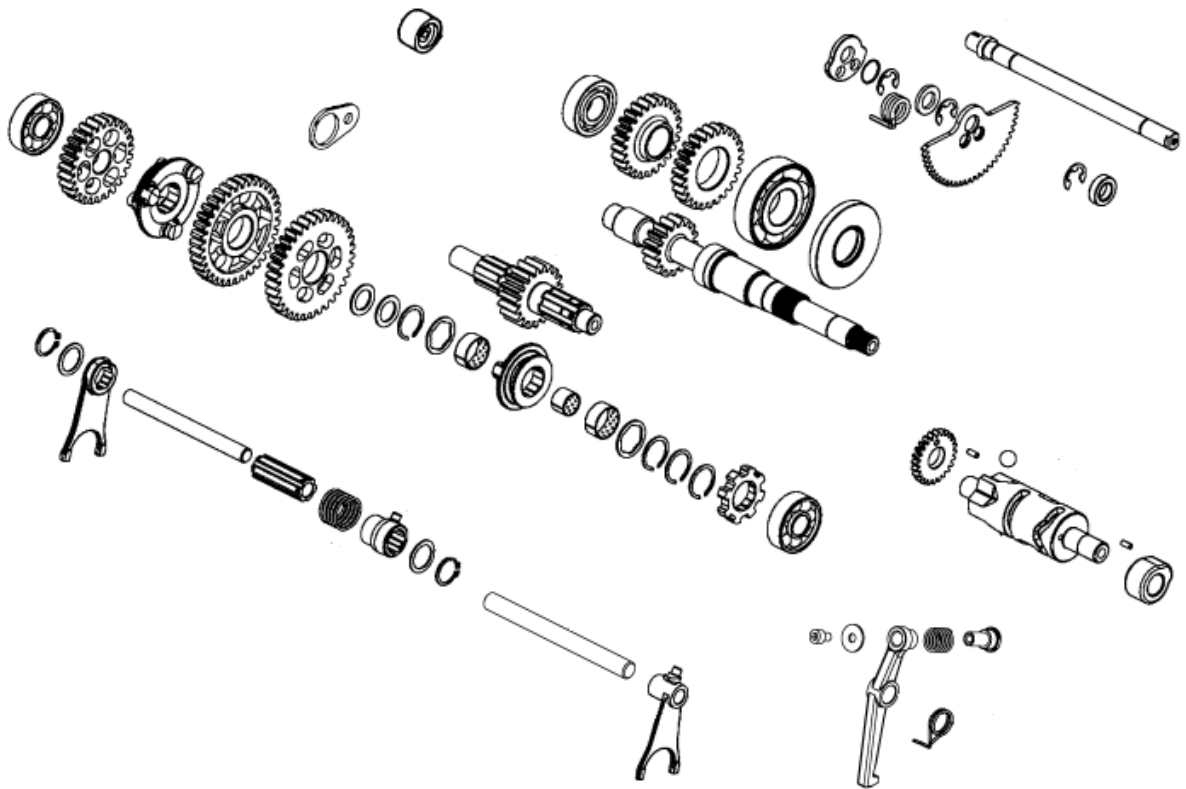

SERVICE INFORMATION

GENERAL INSTRUCTIONS

- The bevel gear and output shaft can be serviced with the engine installed in the frame.

SPECIAL TOOL

Y-type holder	A120E00056
Bearing puller	A120E00037
Bearing drive	A120E00014
Nut wrench	A120E00066

TORQUE VALUES

Crankcase bolt	1.2 kgf-m (12 N-m)	Apply engine oil
Drive bevel gear nut	14 kgf-m (140 N-m)	Apply engine oil
Driven bevel gear nut	14 kgf-m (140 N-m)	Apply engine oil
Stopper lever boss nut	3 kgf-m (30 N-m)	
Stopper lever bolt	2.5 kgf-m (25 N-m)	
Shift cam stopper plug	4.8 kgf-m (48 N-m)	
Output shaft bearing nut	11 kgf-m (110 N-m)	Apply engine oil

TROUBLESHOOTING

Engine starts but motorcycle won't move

- Damaged transmission
- Seized or burnt transmission

Oil leaks

- Oil too rich
- Worn or damaged oil seal

SECONDARY DRIVE/DRIVEN BEVEL GEAR REMOVAL/INSPECTION/INSTAL LATION

REMOVAL

Drain engine oil into a clean container. (Refer to the “ENGINE OIL” section in the chapter 3).

Move the engine assembly forward (refer to the “ENGINE REMOVAL” section in the chapter 6) or remove the rear propeller (refer to the “REAR PROPELLER SHAFT DISASSEMBLY/INSPECTION/ASSEMBLY” section in the chapter 13).

Remove the five bolts, then remove the bevel gear case cover.

Remove the two dowel pins and gasket.

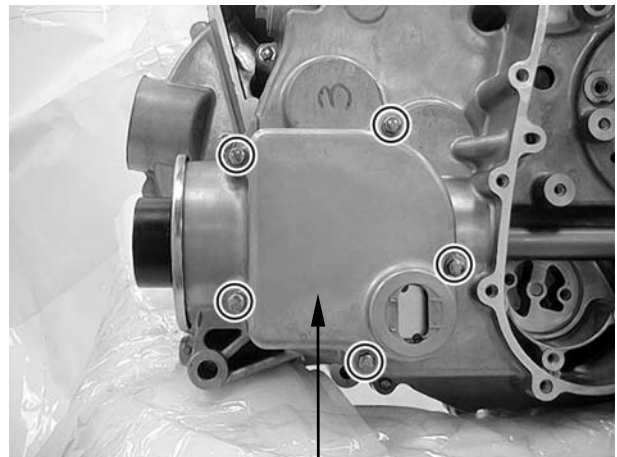

Bevel Gear Case Cover

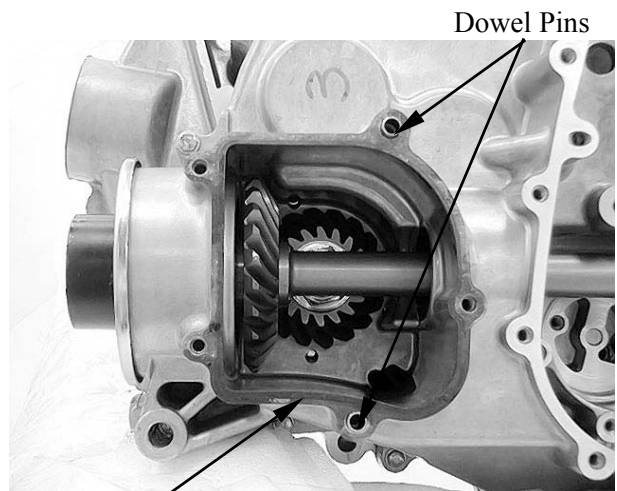

Gasket

Dowel Pins

Using a chisel, unlock the nut in the rear middle joint.

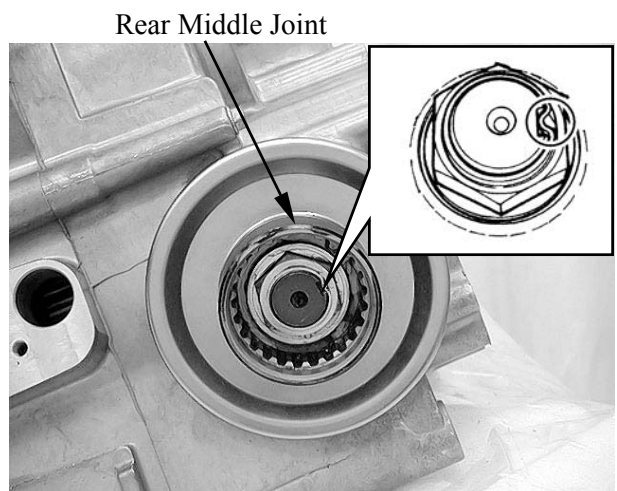

Rear Middle Joint

11.FINAL REDUCTION/ TRANSMISSION SYSTEM

Install the front drive shaft.
Hold universal joint nut by using a suitable bar, then remove the rear propeller shaft nut.

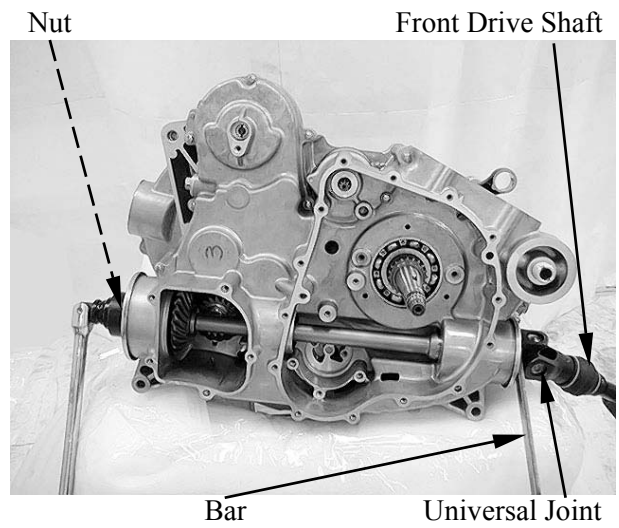

Remove the rear middle joint.

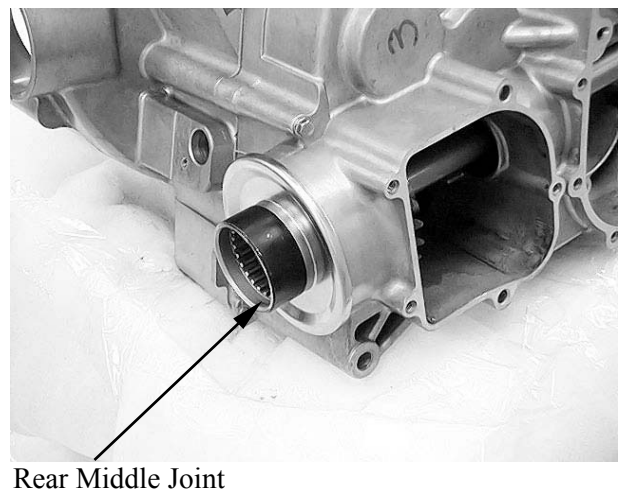

Tap the output shaft by using a rubber hammer, then remove the output shaft, secondary driven bevel gear and shim.

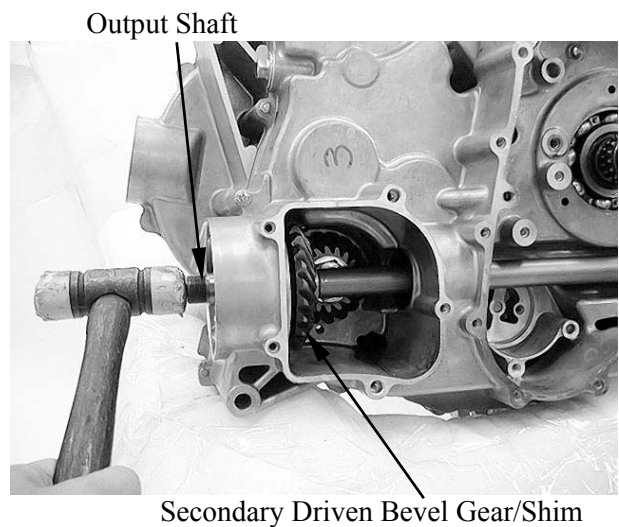

11.FINAL REDUCTION/ TRANSMISSION SYSTEM

Using a chisel, unlock the nut.

Hold the driven pulley by using the special tool (refer to the “DRIVE PULLEY, DRIVE V-BELT AND DRIVEN PULLEY REMOVAL/INSPECTION/INSTALLATION” section in the chapter 10), then remove the nut.

Special tool:

Y-type holder A120E00056

Remove the secondary drive bevel gear.

Remove the shim.

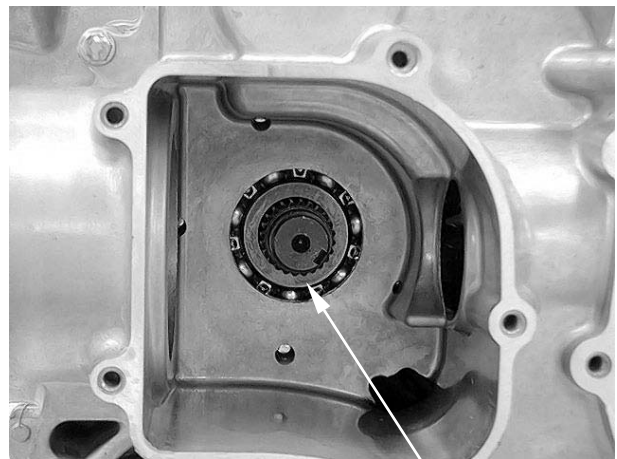
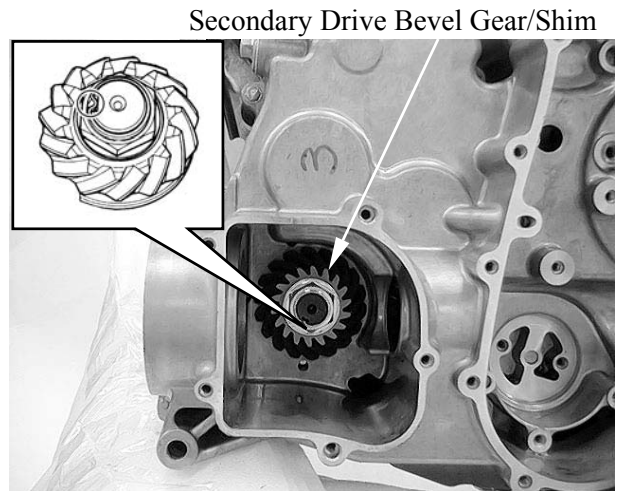

INSPECTION

Check the drive/driven bevel gear teeth for pitting, galling and wear.



11.FINAL REDUCTION/ TRANSMISSION SYSTEM

Inspect the rear middle joint splines for wear or damage.



Inspect the output shaft splines for wear or damage.



INSTALLATION

Install the shim and secondary drive bevel gear.

Holder the driven pulley by using the special tool, then install and tighten the nut to the specified torque.

Torque:

14 kgf-m (140 N-m,) Apply oil

Special tool:

Y-type holder A120E00056

Stake the nut with a center punch.

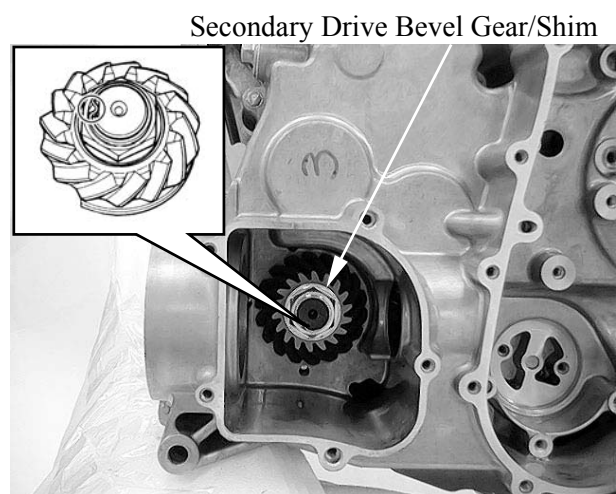

11.FINAL REDUCTION/ TRANSMISSION SYSTEM

 **KYMCO**
MXU 550EXi/MXU500i

Install the output shaft, secondary driven bevel gear and shim

Install the rear middle joint.

Install the front drive shaft.

Hold universal joint nut by using a suitable bar, then install and tighten the rear middle joint nut to the specified torque.

Torque: 14 kgf-m (140 N-m,) Apply oil

Remove the front drive shaft.

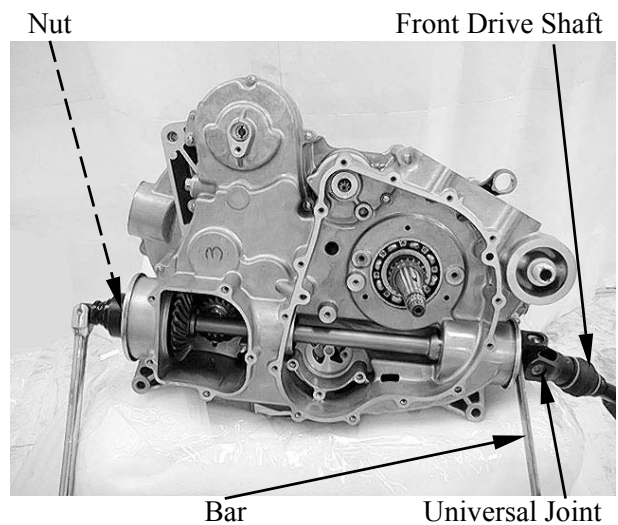

11.FINAL REDUCTION/ TRANSMISSION SYSTEM

SECONDARY GEAR SHIMS ADJUSTMENT

Set a dial gauge on the driven bevel gear as shown.

Measure the backlash by turning the rear propeller shaft in each direction, reading the total backlash on the dial gauge. If the backlash is not within specification, the shim must be changed and the backlash should be rechecked until correct. Refer to the chart for appropriate shim thickness.

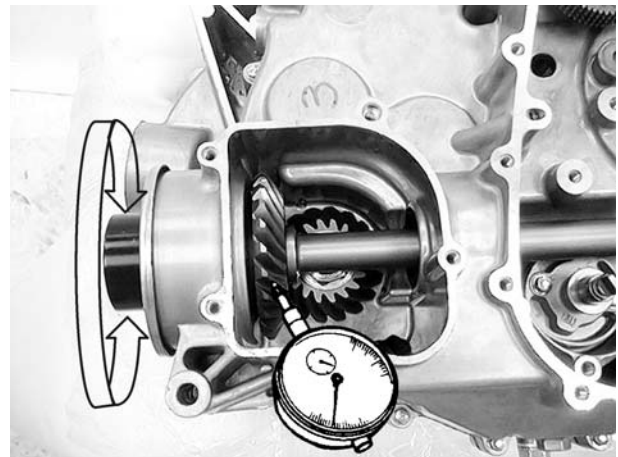

Bevel gear backlash

Standard: 0.03 - 0.15 mm

* Adjust the backlash by referring to the chart at the right and using the thickness of the removed shims as a guide.

Backlash	Shim adjustment
Under 0.03 mm	Decrease shim thickness
0.03 – 0.15 mm	Correct
Over 0.15 mm	Increase shim thickness

Drive/Driven bevel gear shims:

- A: 0.6 mm**
- B: 0.65 mm**
- C: 0.7 mm**
- D: 0.75 mm**
- E: 0.8 mm**
- F: 0.85 mm**
- G: 0.9 mm**
- H: 0.95 mm)**
- I: 1 mm**
- J: 1.05 mm**
- K: 1.1 mm**
- L: 1.15 mm**

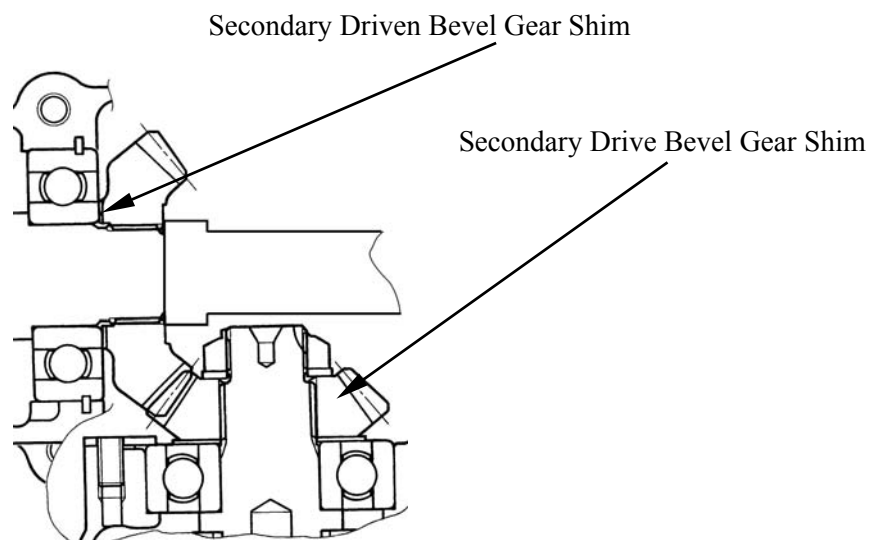

TOOTH CONTACT

After backlash adjustment is carried out, the tooth contact must be checked. Pay attention to the following procedures:

- Remove the driven bevel gear.
- Clean and degrease several teeth of the drive and driven bevel gears.
Apply a coating of machinist's layout dye or paste to several teeth of the driven bevel gear.
- Install the driven bevel gear.
- Rotate the rear propeller shaft several turns in both directions.
- Remove the driven bevel gear and inspect the coated teeth of the drive bevel gear. The tooth contact pattern should be as shown in (1), (2) and (3).
- If tooth contact is found to be correct (example (2)), then to complete installation.

(1): Incorrect (contact at tooth top)

(2): Correct

(3): Incorrect (contact at tooth root)

- If tooth contact is found to be incorrect (examples (1) and (3)), the shim thickness between the drive bevel gear and driven bevel gear must be changed and the tooth contact rechecked until correct.

* Make sure to check the backlash after the tooth contact has been adjusted, since it may have changed. Adjust the tooth contact and backlash until they are both within specification. If the correct tooth contact cannot be maintained when adjusting the backlash, replace the drive and driven bevel gears.

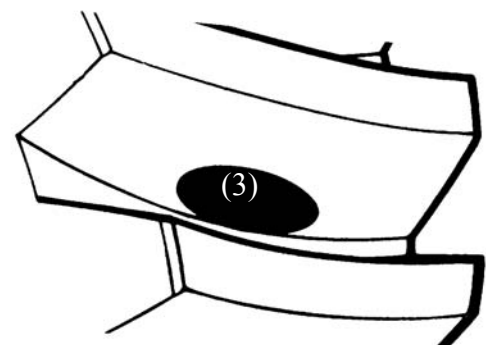
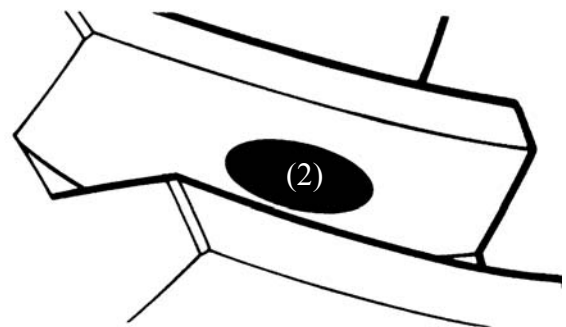

Tooth contact	Drive bevel gear shim adjustment	Driven bevel gear shim adjustment
Contact at tooth top	Increase shim thickness	Increase shim thickness
Contact at tooth root	Decrease shim thickness	Decrease shim thickness

RIGHT CRANKCASE REMOVAL/INSTALLATION

REMOVAL

Remove the cam chain (refer to the “**CAM CHAIN REMOVAL/INSPECTION/INSTALLATION**” section in the chapter 8)

Remove the secondary drive and driven bevel gear (refer to the “**SECONDARY DRIVE/DRIVEN BEVEL GEAR REMOVAL/INSPECTION/INSTALLATION**” section in this chapter).

Remove the stopper plug and washer.

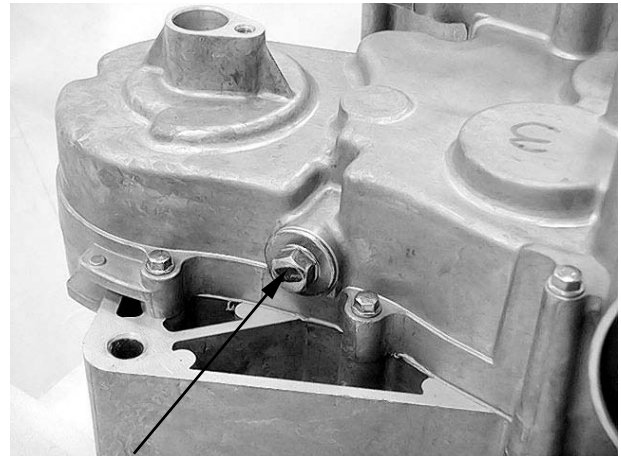

Stopper Plug

Remove the spring and shift cam stopper.



Spring

Remove the four bolts from left crankcase.

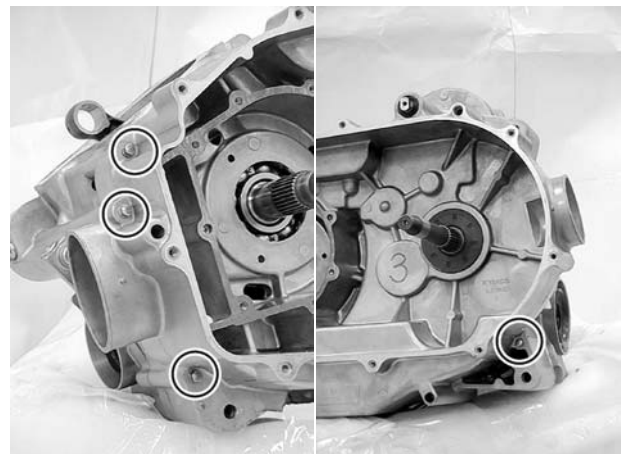

11.FINAL REDUCTION/ TRANSMISSION SYSTEM

KYMCO
MXU 550EXi/MXU500i

Remove the fifteen bolts from right crankcase.

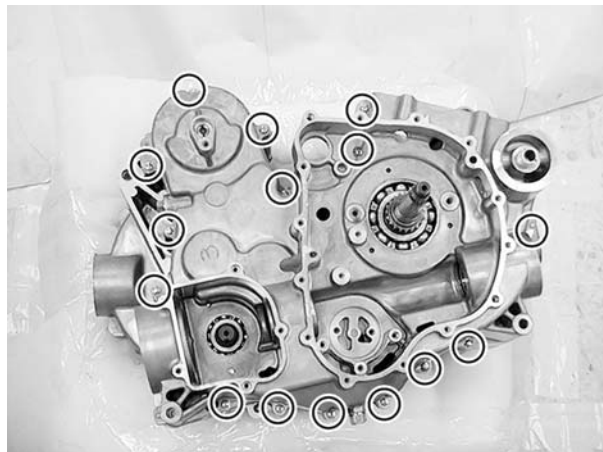

Remove the two dowel pins.

INSTALLATION

Apply a light but thorough coating of liquid gasket (Threebond 1215 or equivalent) to all crankcase mating surfaces except the oil passage area.

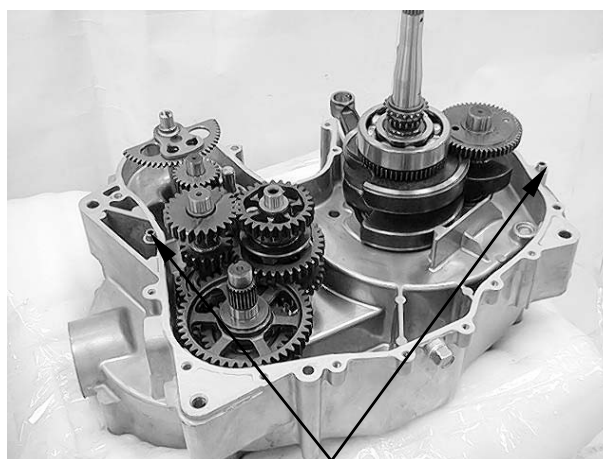

Dowel Pins

Install the right crankcase and tighten the bolts in a crisscross pattern in 2 or 3 steps.

Torque:

1.2 kgf-m (12 N-m, 8.6 lbf-ft) Apply oil

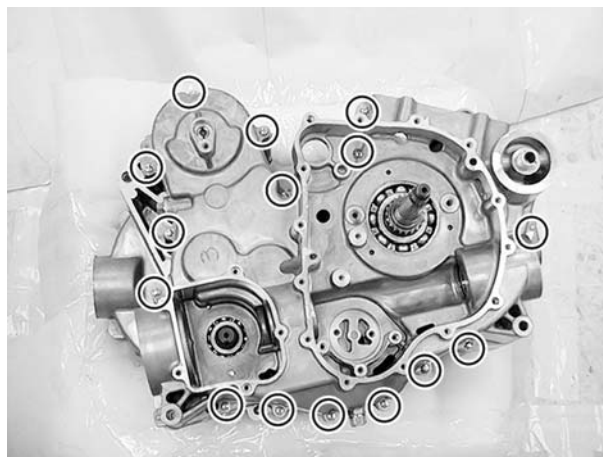

11.FINAL REDUCTION/ TRANSMISSION SYSTEM

Install and tighten the bolts in a crisscross pattern in 2 or 3 steps.

Torque: 1.2 kgf-m (12 N-m,) Apply oil

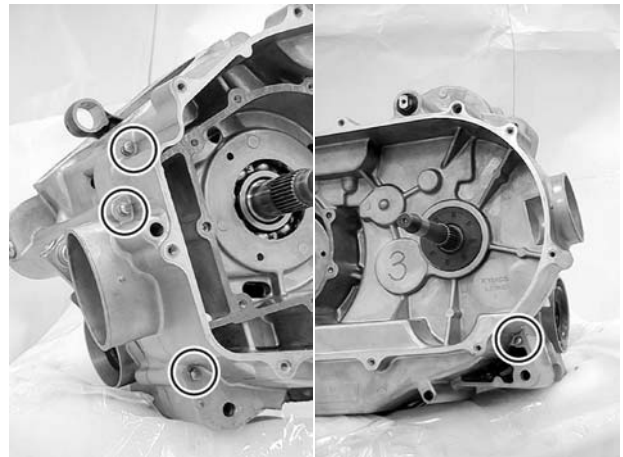

Install the stopper, spring, washer and plug.
Tighten the stopper plug to the specified torque.

Torque: 4.8 kgf-m (48 N-m)

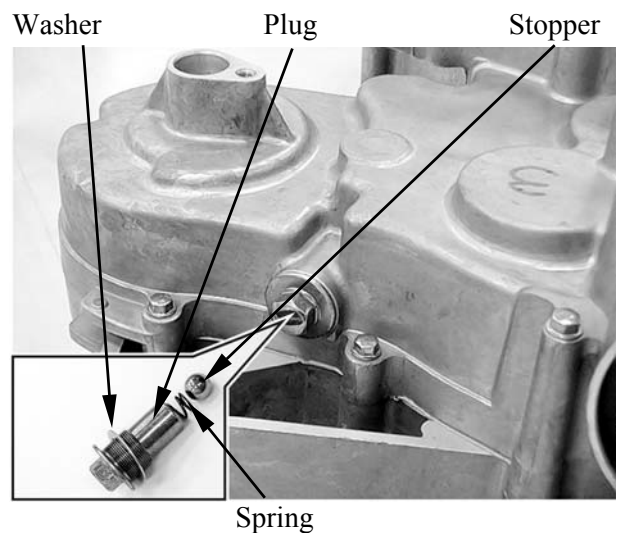

BEARING REPLACEMENT IN THE RIGHT CRANKCASE

BALANCE SHAFT/COUNTERSHAFT/ PRIMARY DRIVE SHAFT BEARING REPLACEMENT

Remove the balance shaft/countershaft/primary drive shaft bearing by using the special tool.

Special tool:

Bearing puller

A120E00037

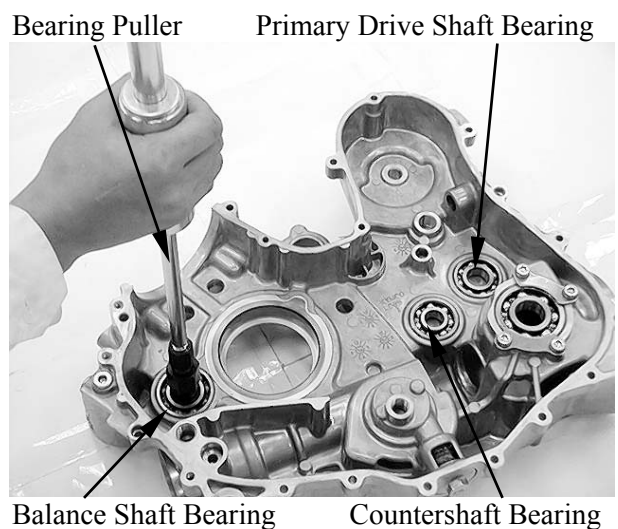

11.FINAL REDUCTION/ TRANSMISSION SYSTEM

 **KYMCO**
MXU 550EXi/MXU500i

Install the new balance shaft/countershaft/primary drive shaft bearing by using the special tool.

Special tool:

Bearing driver A120E00014

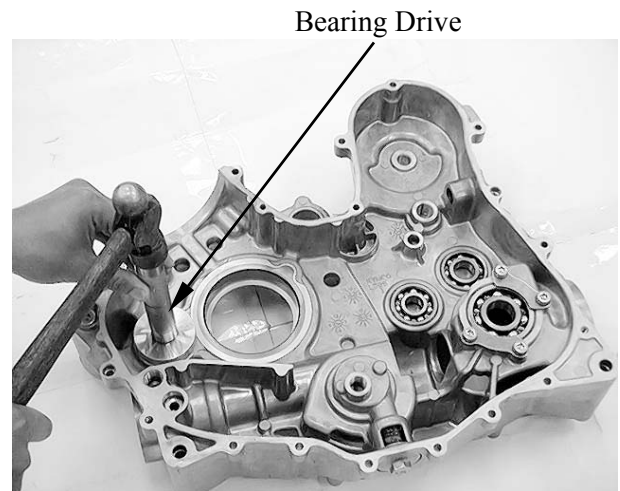

DRIVE SHAFT BEARING REPLACEMENT

Remove the four bolts and two Set plates.

Remove the bearing.

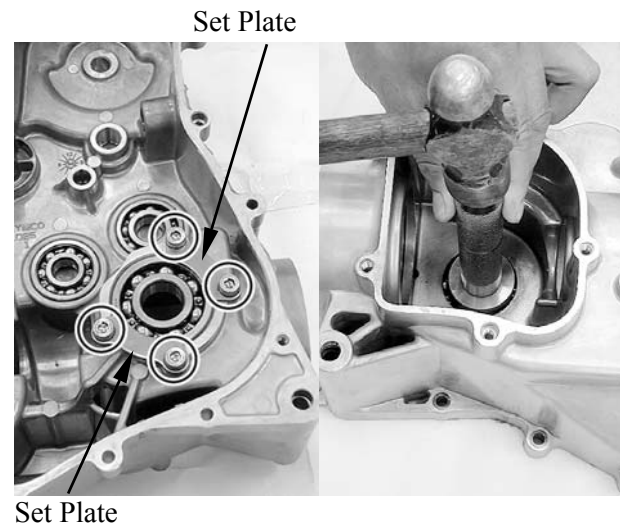

Install the new bearing by using the special tool.

Special tool:

Bearing driver A120E00014

Install the set plates and tighten the new bolts.

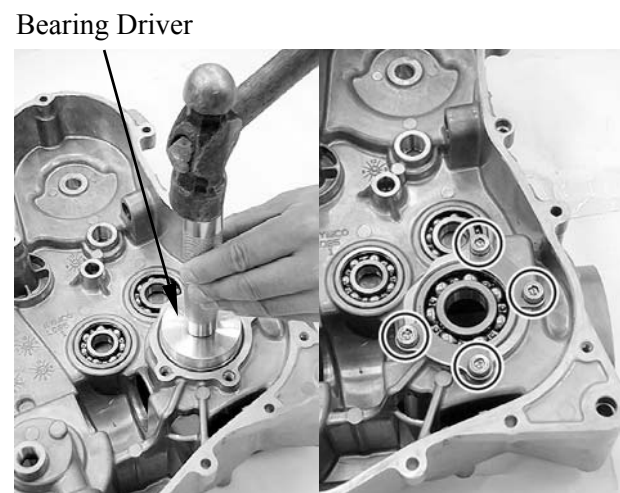

11.FINAL REDUCTION/ TRANSMISSION SYSTEM

OUTPUT SHAFT FRONT/REAR BEARING REPLACEMENT

* The output shaft bearings can be replaced when the crankcase is assembly.

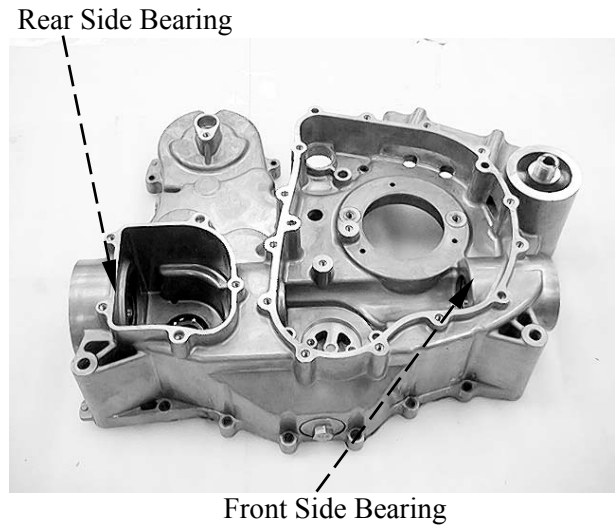

REAR SIDE BEARING

Remove the oil seal.

Remove the nut by using the special tool.

Special tool:

Nut wrench A120E00066

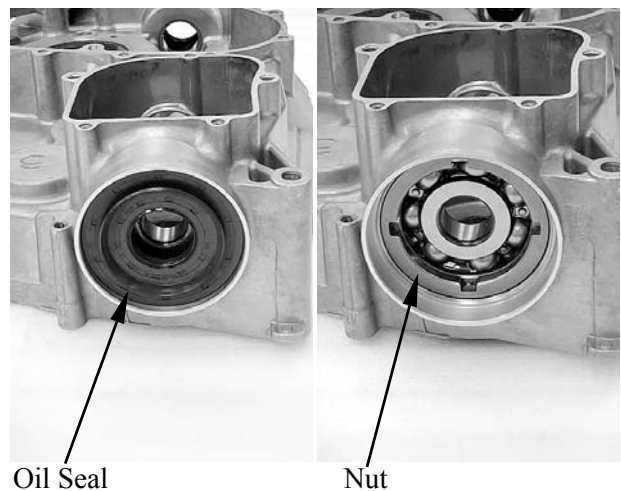

Remove the bearing by using the special tool.

Special tool:

Bearing Puller A120E00037

Install the new bearing.

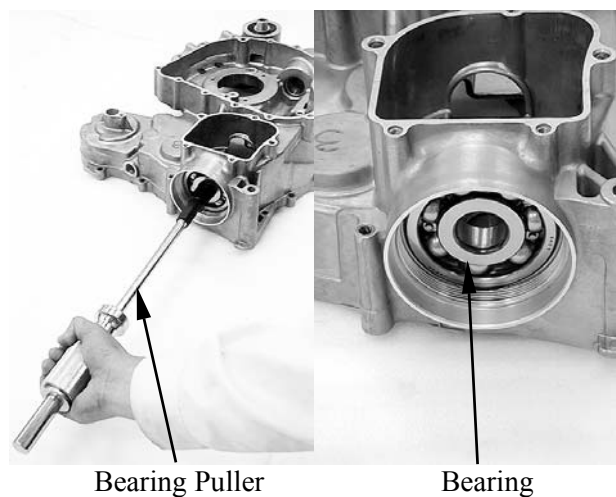

11.FINAL REDUCTION/ TRANSMISSION SYSTEM

 **KYMCO**
MXU 550EXi/MXU500i

Install and tighten the nut to the specified torque by using the special tool.

Torque: 11 kgf-m (110 N-m)

Special tool:

Nut wrench A120E00066

Apply clean engine oil to the new oil seal lip then install the oil seal.

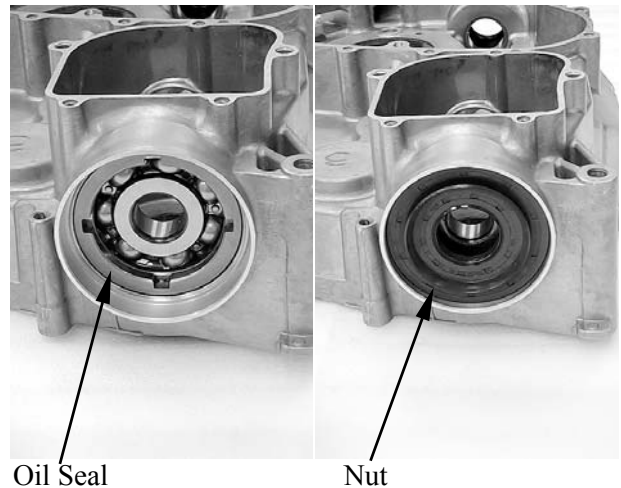

FRONT SIDE BEARING

Remove the oil seal.

Remove the snap ring.

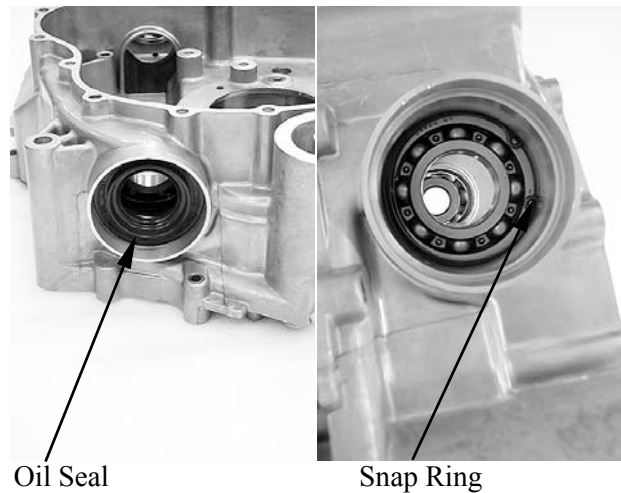

Remove the bearing by using the special tool.

Special tool:

Bearing Puller A120E00037

Install the new bearing by using the special tool.

Special tool:

Bearing driver A120E00014

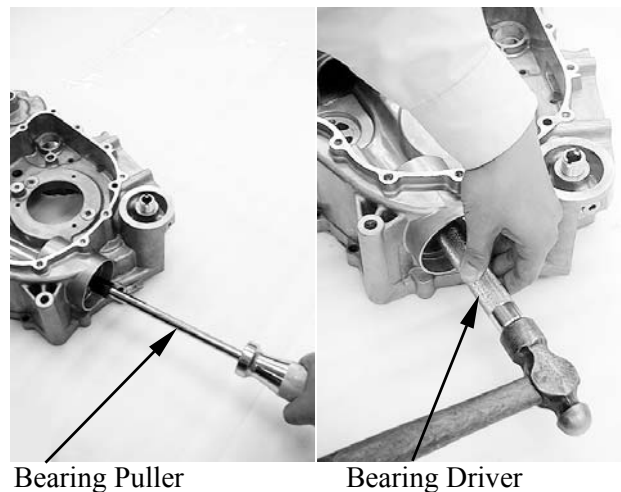

11.FINAL REDUCTION/ TRANSMISSION SYSTEM

Install the snap ring.

Apply clean engine oil to the new oil seal lip
then install the new seal.

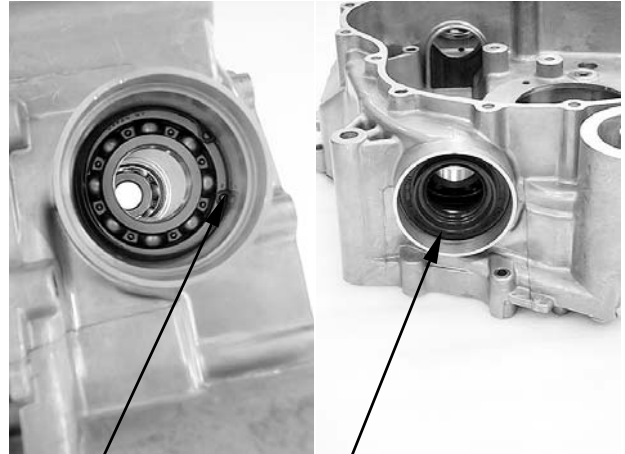

Snap Ring

Oil Seal

11.FINAL REDUCTION/ TRANSMISSION SYSTEM

KYMCO
MXU 550EXi/MXU500i

TRANSMISSION REMOVAL/INSPECTION/ INSTALLATION

REMOVAL

Remove the bolt and then remove the shift arm.

Remove the right crankcase (refer to the “**RIGHT CRANKCASE REMOVAL/INSTALLATION**” section in this chapter)

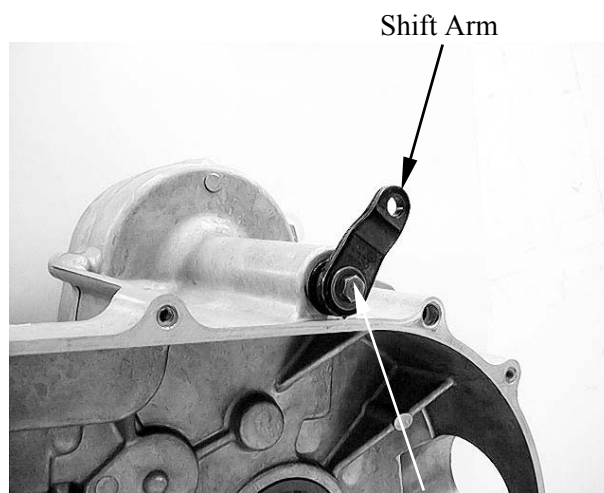

Bolt

Remove the shift shaft.

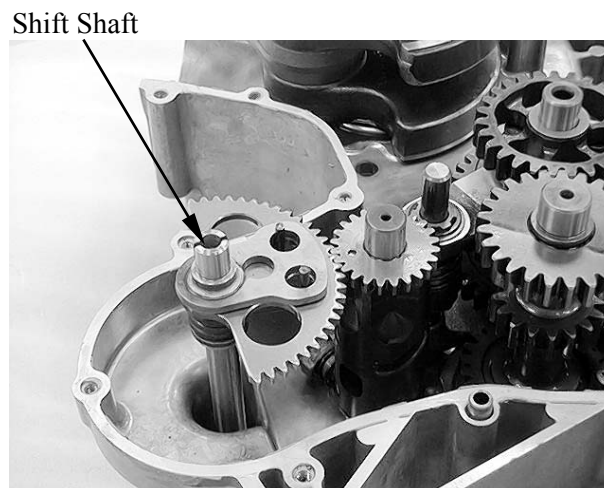

Remove the transmission guide bar.

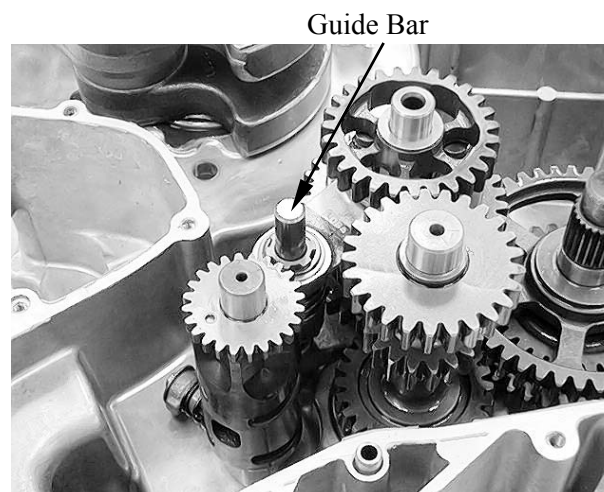

11.FINAL REDUCTION/ TRANSMISSION SYSTEM

Remove the upper shift fork.
Remove the lower shift fork.

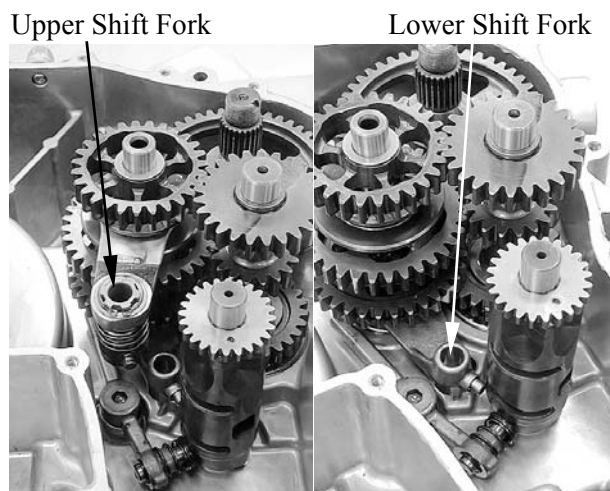

Remove the shift cam.

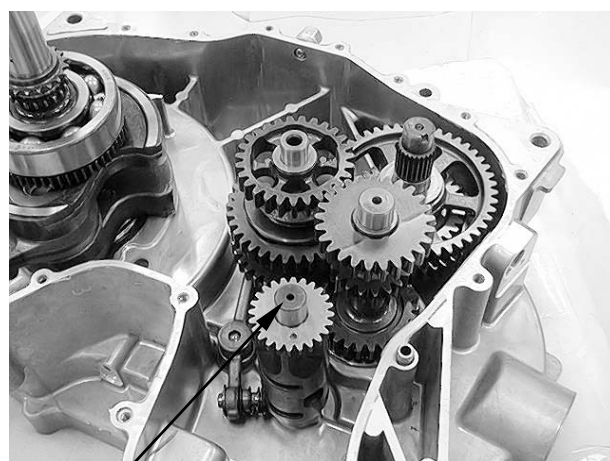

Shift Cam

Remove the countershaft and driveshaft as an assembly.

Disassemble the countershaft and the driveshaft.

* Keep track of the disassembled parts (gears, washer and clip) by stacking them on a tool or slipping them onto a piece of wire.

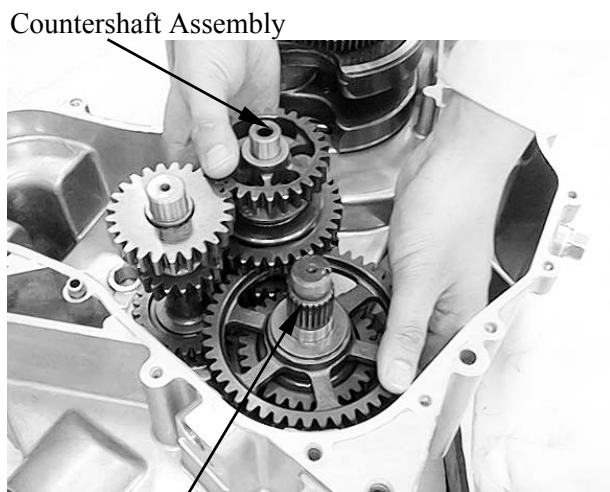

Driveshaft Assembly

11.FINAL REDUCTION/ TRANSMISSION SYSTEM

KYMCO
MXU 550EXi/MXU500i

Remove the primary drive shaft.

Primary Drive Shaft

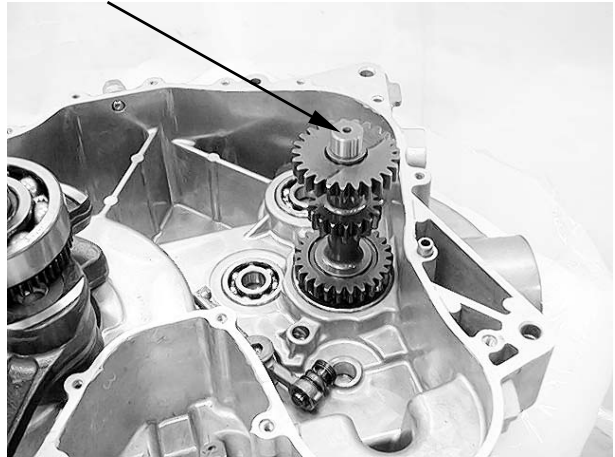

Remove the bolt/washer, then remove the stopper lever and spring.

Spring

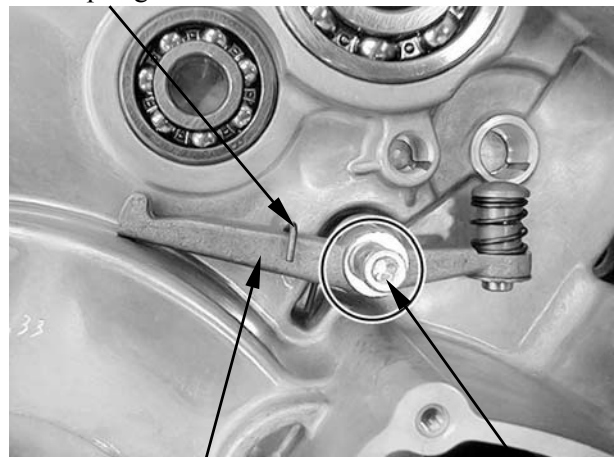

Stopper Lever

Bolt/Washer

INSPECTION

Guide bar

Measure the guide bar runout.
Out of specification → Replace.

Service Limit:

Less than 0.03 mm (0.0012 in)

* Do not attempt to straighten a bent guide bar.

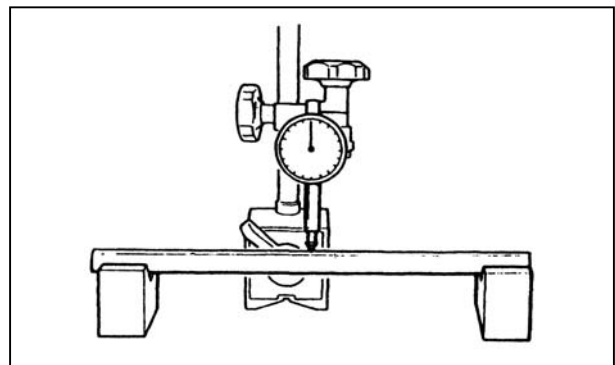

11.FINAL REDUCTION/ TRANSMISSION SYSTEM

Upper shift fork

Inspect the shift fork cam follower and shift fork pawl.
Scoring/beads/wear → Replace a set.

Inspection the spring.
Cracks or damage → Replace a set..

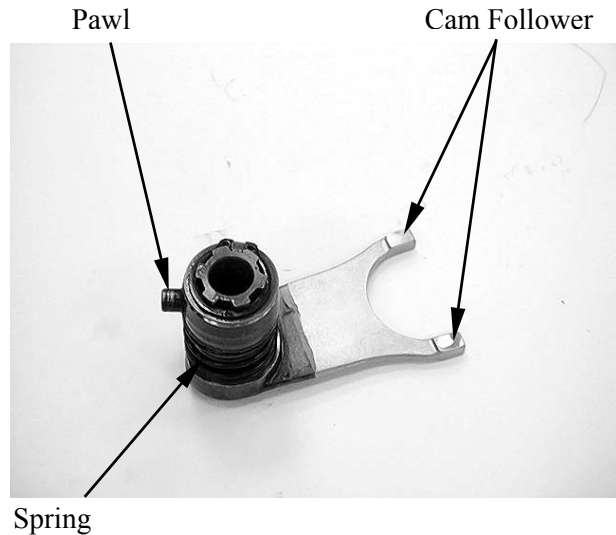

Lower shift fork

Inspect the shift fork cam follower and shift fork pawl.
Scoring/beads/wear → Replace.

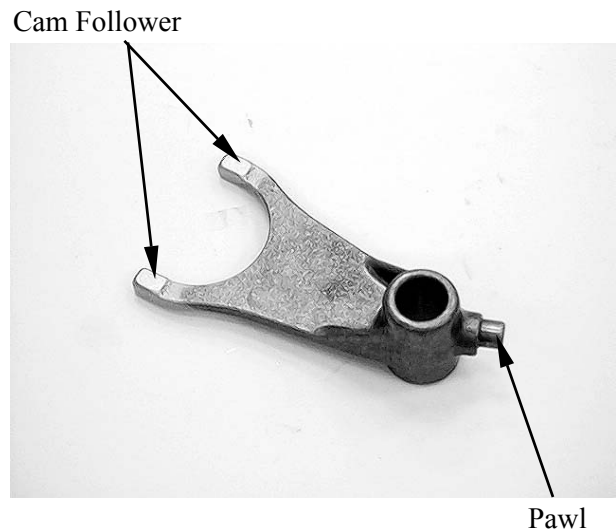

Primary drive shaft

Check the gear teeth for blue discoloration, pitting or wear.

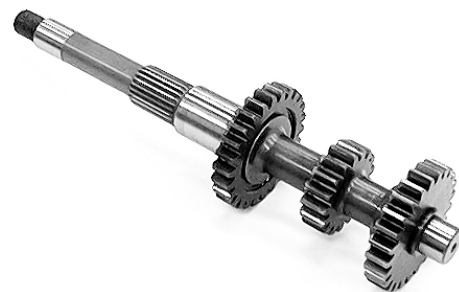

11.FINAL REDUCTION/ TRANSMISSION SYSTEM

Stopper lever

Check the stopper lever pawl for bends, damage or wear.

Inspect the spring for cracks or damage.



Check the shift cam groove and shift cam gear.

Wear or damage → Replace.



Inspect shift shaft gear.

Damage → Replace.

Inspect shift shaft.

Damage/bends/wear → Replace.

Check the return spring for fatigue or damage.



11.FINAL REDUCTION/ TRANSMISSION SYSTEM

INSTALLATION

Make sure the shaft nut specified torque in the V-belt compartment while holds the stopper lever shaft.

Torque: 3 kgf-m (30 N-m, 21.6 lbf-ft)

Stopper Lever Shaft



Nut

Hook the spring onto the hook part of the stopper lever, squeeze the spring in to the groove of the left crankcase.

Stopper Lever

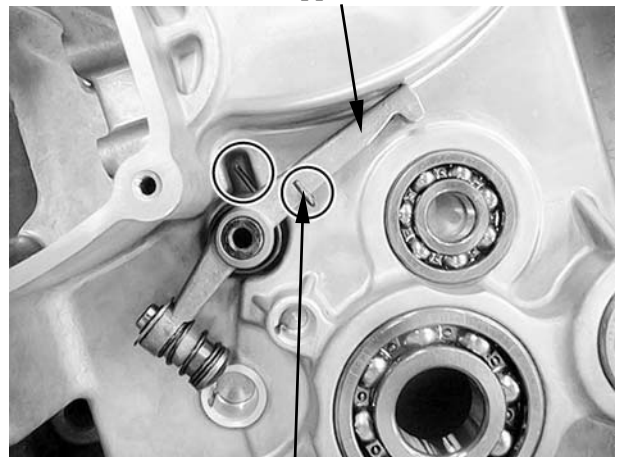

Spring

Install the washer and a new bolt.
Tighten the bolt to the specified torque while holds the shaft nut in the drive V-belt compartment.

Torque: 2.5 kgf-m (25 N-m, 18 lbf-ft)

Bolt/Washer

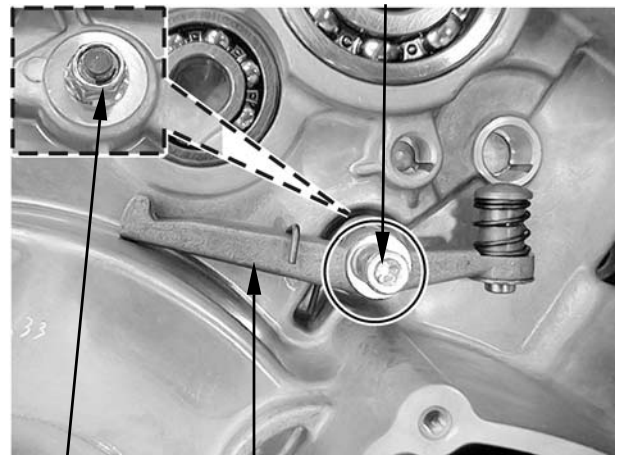

Shaft Nut

Stopper Lever

11.FINAL REDUCTION/ TRANSMISSION SYSTEM

KYMCO
MXU 550EXi/MXU500i

Apply clean engine oil to the countershaft assembly, driveshaft assembly and primary drive shaft.

Install the primary drive shaft.
Install the countershaft and drive shaft assemblies as a set into the left crankcase.

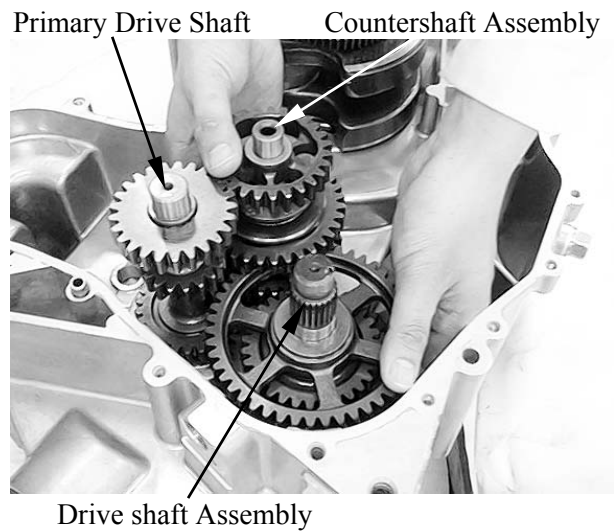

Apply clean engine oil to the shift cam, then install the shift cam.

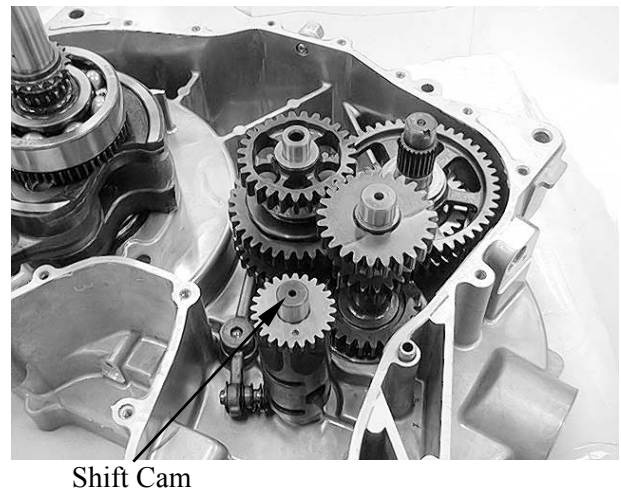

Apply clean engine oil to the gearshift fork, sliding surface and gearshift fork pawl.

Install the lower gearshift fork into the clutch dog (countershaft) and shift cam grooves with its "LDB5" mark facing down.

Install the upper gearshift fork into the clutch dog (countershaft) and shift cam grooves with its "LDB5" mark facing up.

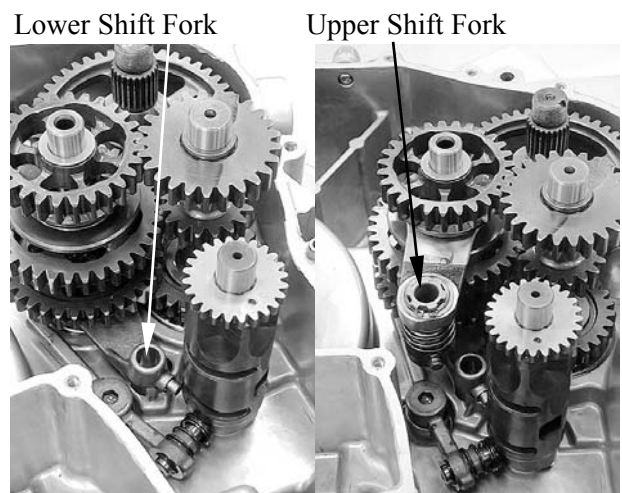

11.FINAL REDUCTION/ TRANSMISSION SYSTEM

Apply the engine oil to the guide bar, then install the guide bar.



Install the shift shaft.

* Align the mark on the shift shaft gear with the mark on the shift cam gear.



Shift Shaft

Check the transmission operation.
Unsmooth operation → Repair.



11.FINAL REDUCTION/ TRANSMISSION SYSTEM

KYMCO
MXU 550EXi/MXU500i

UPPER SHIFT FORK DISASSEMBLY/ASSEMBLY

DISASSEMBLY

Remove the upper shift fork (refer to the "TRANSMISSION REMOVAL/INSPECTION/INSTALLATION" section in this chapter)

Remove the snap ring, washer and fork.

Remove the spring, cam pawl and washer.

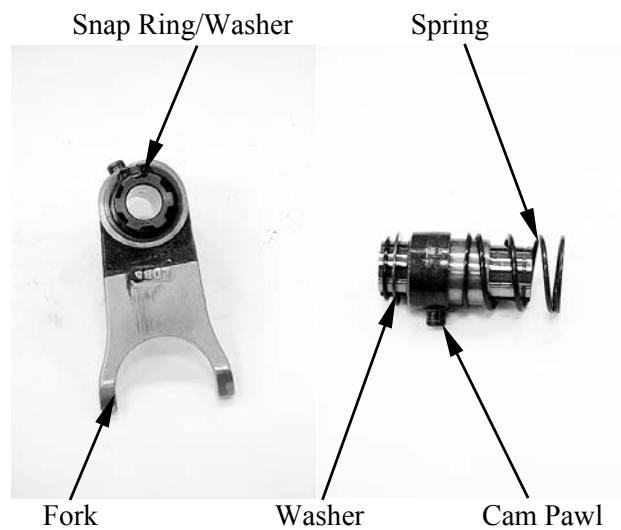

ASSEMBLY

Install the washer and cam pawl.

* Align the mark on the cam pawl with the mark on the shaft.

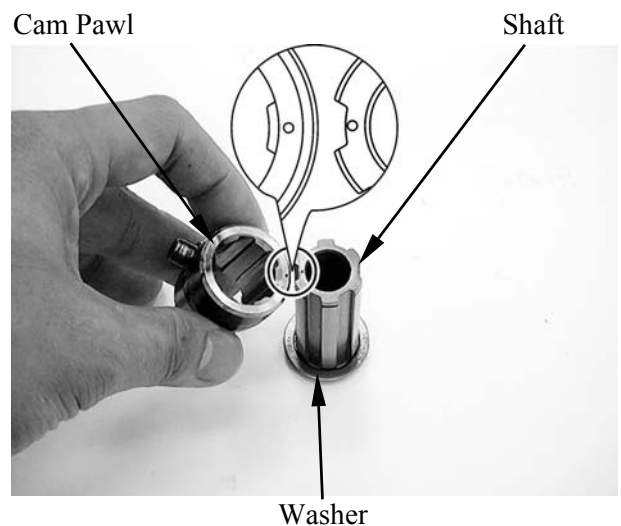

Install the spring.
Install the fork.

* Align the mark on the fork with the mark on the shaft.

Install the washer and snap ring.

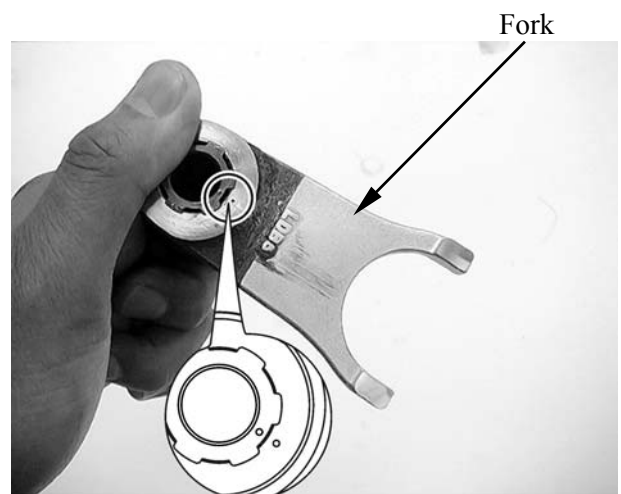

11.FINAL REDUCTION/ TRANSMISSION SYSTEM

DRIVE SHAFT DISASSEMBLY/ASSEMBLY/ INSPECTION

DISASSEMBLY

Remove the drive shaft assembly (refer to the “TRANSMISSION REMOVAL/INSPECTION/ INSTALLATION” section in this chapter).

Remove the washer (thick) and reverse gear.

Remove the washer (thin).

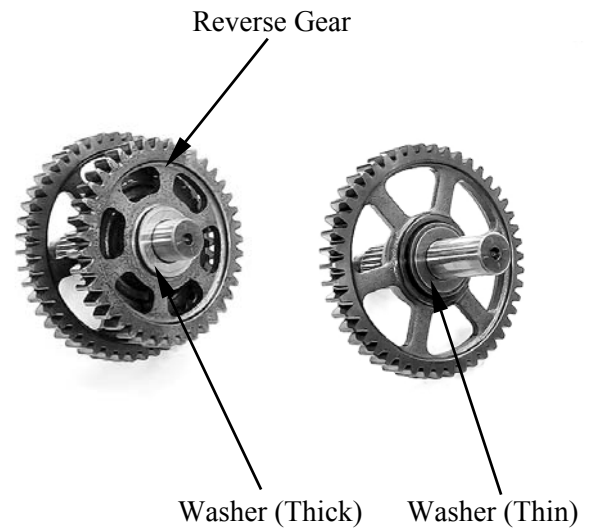

ASSEMBLY/INSPECTION

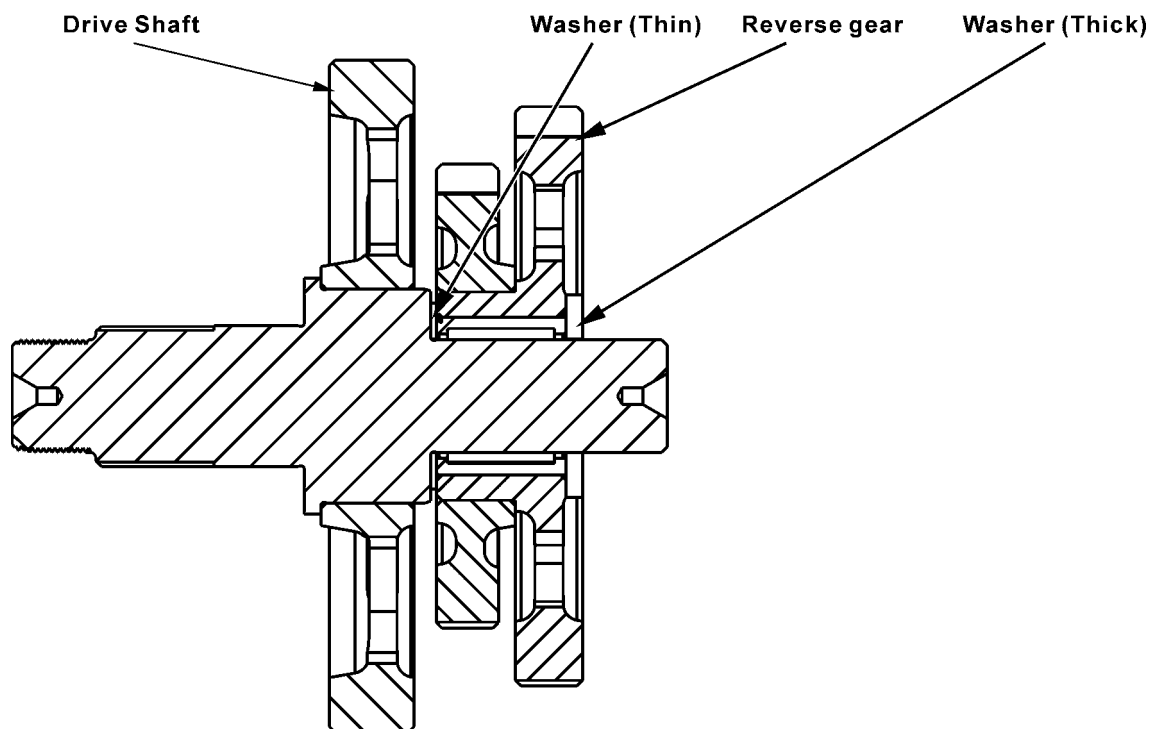

Inspect the gear teeth.
Blue discoloration/pitting/wear → Replace.

Inspect the needle bearing in the reverse gear.
Wear/damage → Replace.

11.FINAL REDUCTION/ TRANSMISSION SYSTEM

COUNTERSHAFT DISASSEMBLY/ASSEMBLY/ INSPECTION

DISASSEMBLY

Remove the countershaft assembly (refer to the “TRANSMISSION REMOVAL/INSPECTION/ INSTALLATION” section in this chapter).

Remove the washer and high drive gear.

Remove the high/low gear clutch dog.

Remove the clip, then remove the washer and low drive gear.

Remove the clip, then remove the stopper wheel.

Remove the clip, then remove reverse gear clutch dog.

Remove the clip, then remove the washer and reverse drive gear.

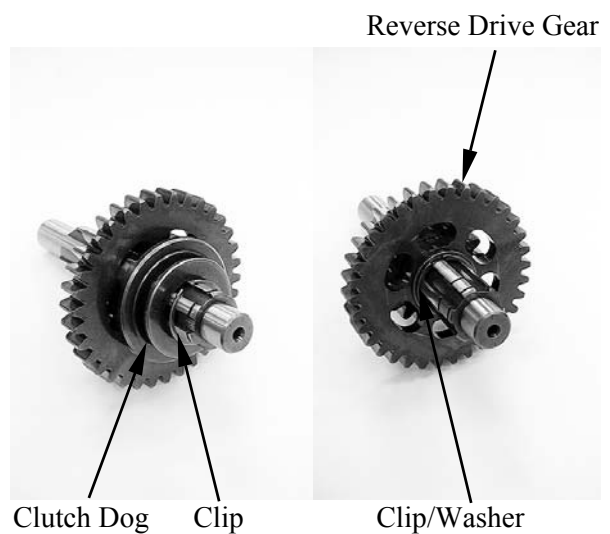
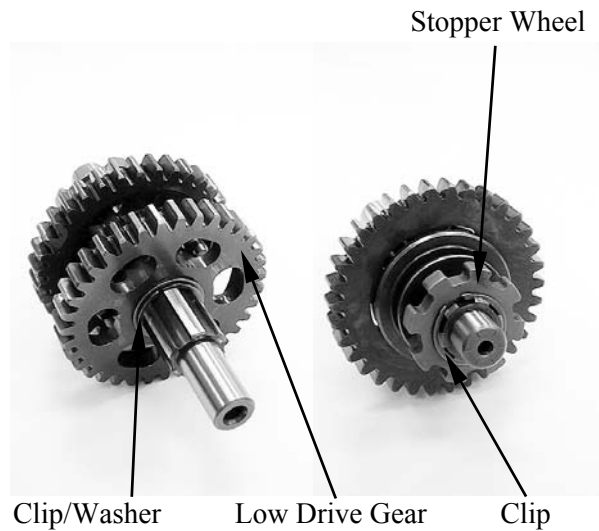
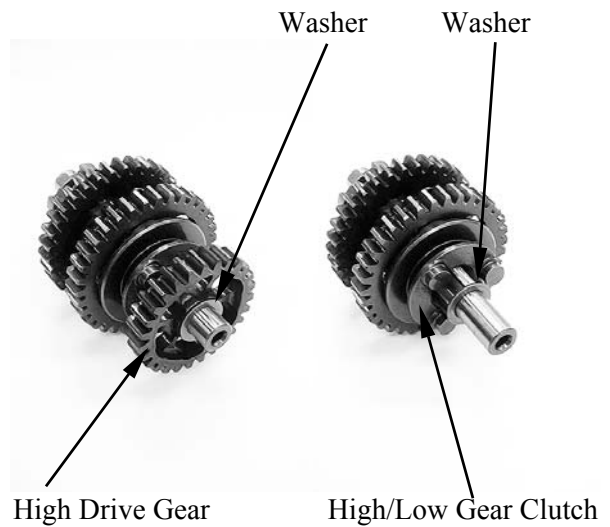

11.FINAL REDUCTION/ TRANSMISSION SYSTEM

ASSEMBLY/INSPECTION

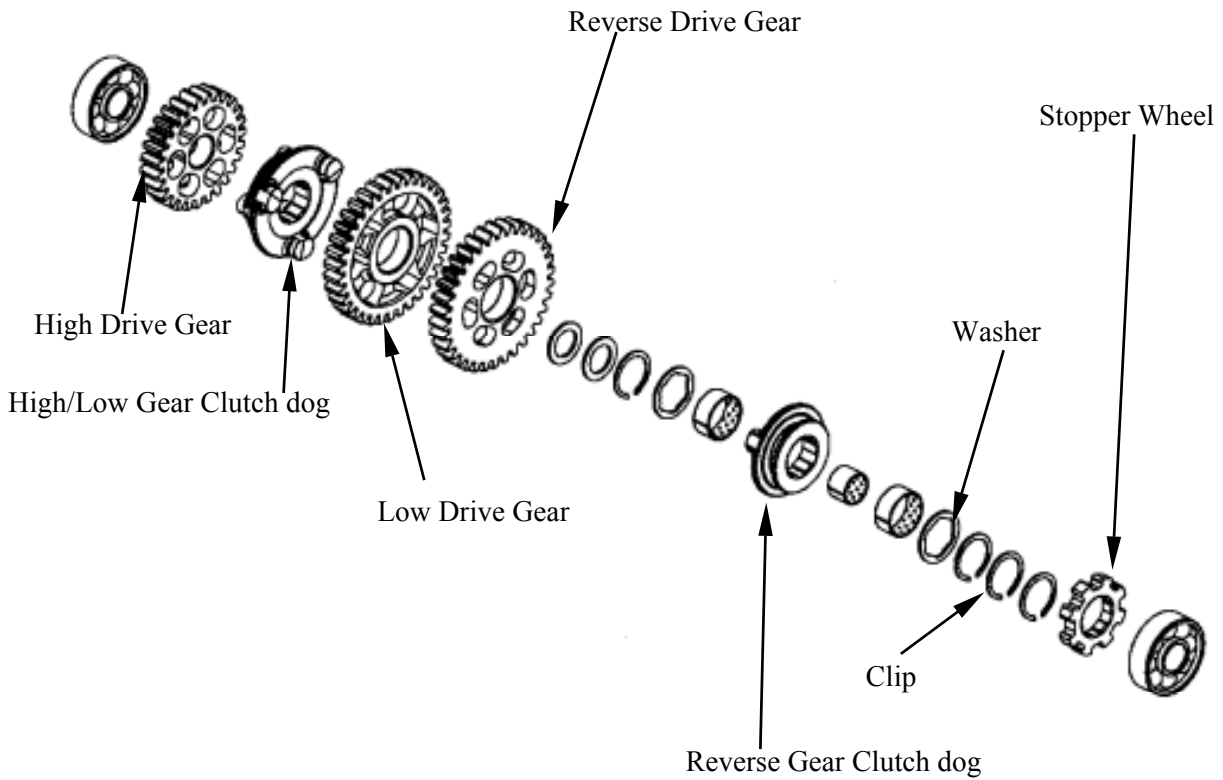

Inspect the gear teeth.
Blue discoloration/pitting/wear → Replace.

Inspect the mated dogs.
Rounded edges/cracks/missing portions
→ Replace.

12.LEFT CRANKSCASE/CRANKSHAFT/ BALANCE SHAFT

MXU 550EXi/MXU500i

LEFT CRANKCASE/CRANKSHAFT/BALANCE SHAFT

SERVICE INFORMATION-----	12- 2
TROUBLESHOOTING-----	12- 2
CRANK SHAFT AND BALANCE SHAFT REMOVAL/INSPECTION/INSTALLATION -----	12- 3
BEARING/OIL SEAL REPLACEMENT IN THE LEFT CRANKCASE-----	12- 6

12.LEFT CRANKCASE/CRANKSHAFT/ BALANCE SHAFT

MXU 550EXi/MXU500i

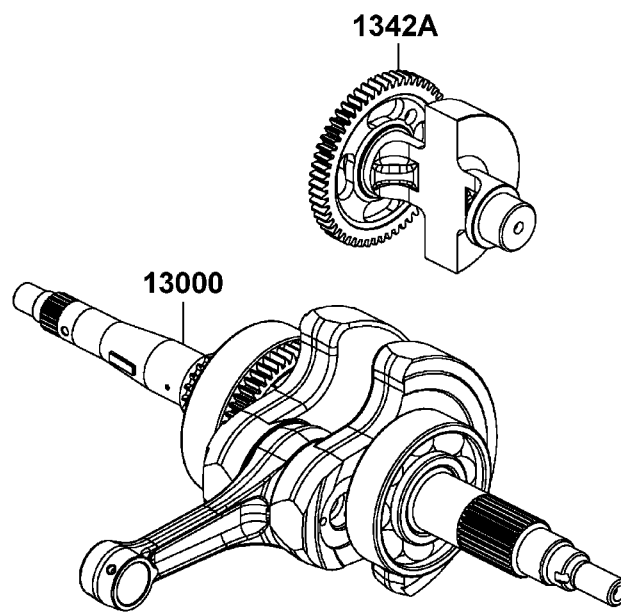

12.LEFT CRANKCASE/CRANKSHAFT/ BALANCE SHAFT

MXU 550EXi/MXU500i

SERVICE INFORMATION

GENERAL INSTRUCTIONS

- This section covers crankcase separation to service the crankshaft. The engine must be removed for this operation.
- The following parts must be removed before separating the crankcase.
 - Cylinder head (⇒Chapter 8)
 - Cylinder/piston (⇒Chapter 9)
 - Drive and driven pulleys (⇒Chapter 10)
 - A.C. generator (⇒Chapter 17)
 - Starter clutch (⇒Chapter 19)
 - Oil pump (⇒Chapter 4)

SPECIFICATIONS

Unit: mm (in)

	Item		Standard	Service Limit
Crankshaft	Connecting rod big end side clearance	On road type	0.01 ~ 0.4 (0.002 ~ 0.016)	0.6 (0.024)
		Off road type	0.3 ~ 0.6 (0.012 ~ 0.024)	0.8 (0.032)
	Connecting rod big end radial clearance		0 ~ 0.008 (0 ~ 0.00032)	0.05 (0.002)
	Run out		—	0.1 (0.004)

TROUBLESHOOTING

Excessive engine noise

Excessive bearing play

12.LEFT CRANKCASE/CRANKSHAFT/ BALANCE SHAFT

MXU 550EXi/MXU500i

CRANKSHAFT AND BALANCE SHAFT REMOVAL/INSPECTION/ INSTALLATION

REMOVAL

Remove the right crankcase (refer to the “**RIGHT CRANKCASE REMOVAL/INSTALLATION**” section in the chapter 11).

Remove the crankshaft and balance shaft together.

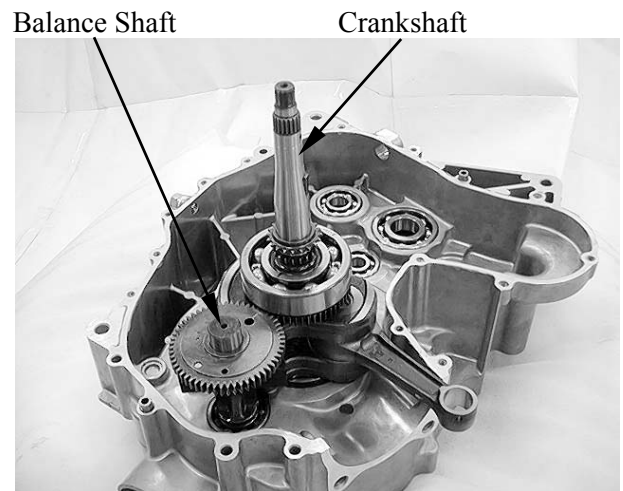

INSPECTION

Balance shaft

Inspect the balance shaft gear teeth.
Burr/chips/roughness/wear → Replace.



Crankshaft inspection

Inspect the crankshaft gear teeth.
Burr/chips/roughness/wear → Replace.

Measure the connecting rod small end I.D.

Service Limit (replace if over):
22.06 mm (0.8824 in)



12.LEFT CRANKSCASE/CRANKSHAFT/ BALANCE SHAFT

MXU 550EXi/MXU500i

Measure the connecting rod small end free play (A).

Out of specification:

0.8 ~ 1 mm (0.032 ~ 0.04 in)

→ Replace the crankshaft.

Measure the crankshaft run out (B).

Service Limit (replace if over):

0.1 mm (0.004 in)

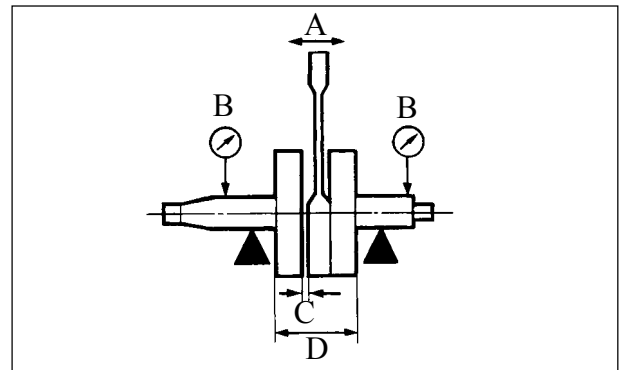

Measure the connecting rod big end side clearance (C).

Service Limit (replace if over):

Not USA type: 0.6 mm (0.024 in)

USA type : 0.8 mm (0.032 in)

Measure the crank width (D).

Out of specification:

72 ~ 72.05 mm (2.88 ~ 2.882 in)

→ Replace the crankshaft.

Turn the crankshaft bearings and check for excessive play.

Measure the crankshaft bearing play.

Service Limit (replace if over):

Axial : 0.2 mm (0.008 in)

Radial : 0.05 mm (0.002 in)

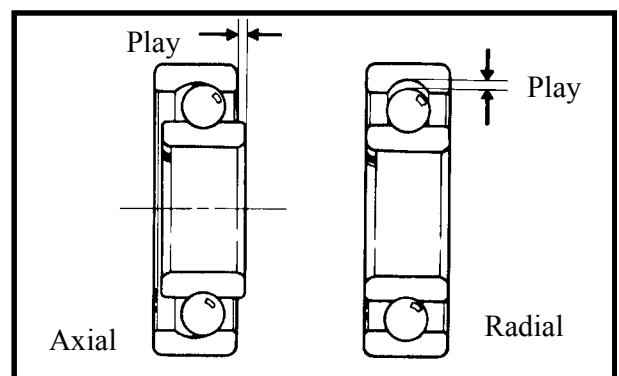

12.LEFT CRANKCASE/CRANKSHAFT/ BALANCE SHAFT

MXU 550EXi/MXU500i

INSTALLATION

Install the balance shaft and crankshaft into the left crankcase.

- *

Align the mark on the balance shaft with the mark on the crankshaft.
--

Mark (on the Balance Shaft)

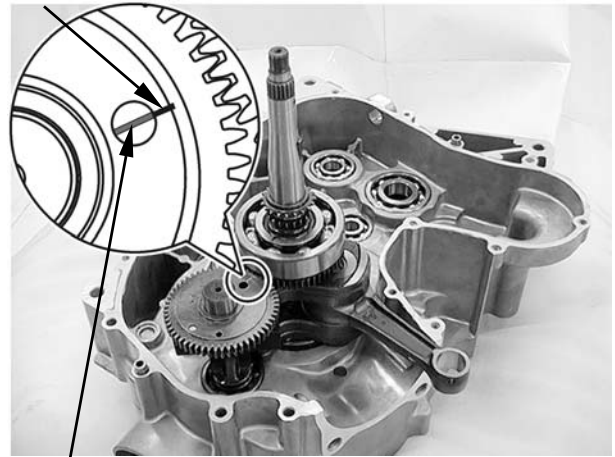

Mark (on the Crankshaft)

12.LEFT CRANKCASE/CRANKSHAFT/ BALANCE SHAFT

MXU 550EXi/MXU500i

BEARING/OIL SEAL REPLACEMENT IN THE LEFT CRANKCASE

BALANCE SHAFT/COUNTERSHAFT/ PRIMARY DRIVE SHAFT/BALANCE SHAFT BEARING REPLACEMENT

Remove the balance shaft/countershaft/primary drive shaft /drive shaft bearing by using the special tool.

Special tool:

Bearing puller A120E00037

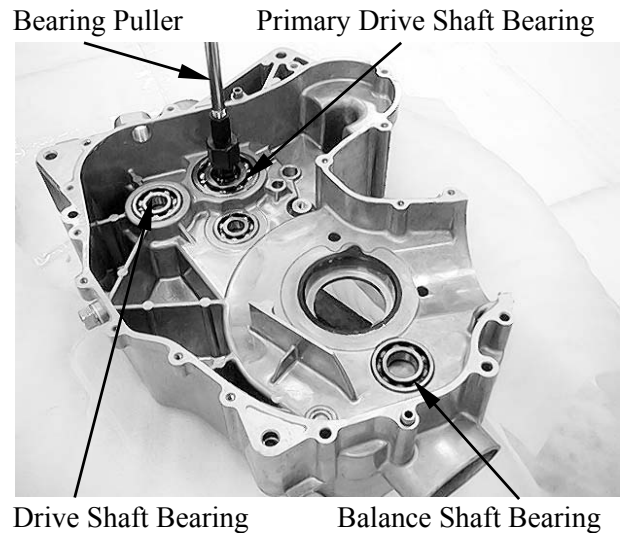

Install the new bearing by using the special tool.

Special tool:

Bearing driver A120E00014



Check the oil seals
Wear or damage → replace

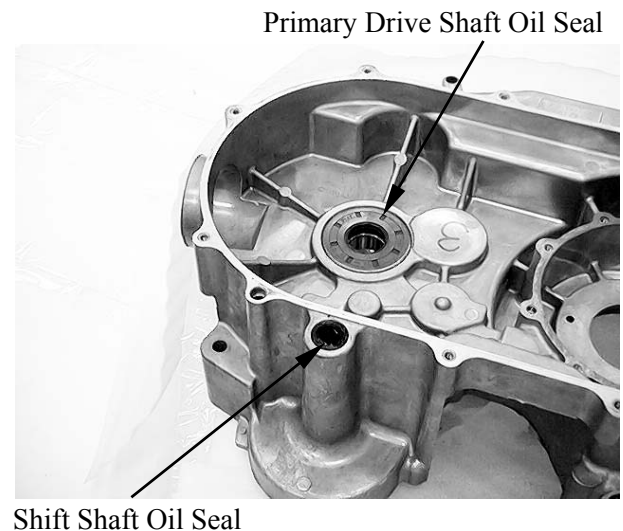

DRIVE TRAIN

SERVICE INFORMATION-----	13- 2
TROUBLESHOOTING-----	13- 2
FRONT ASSY CVJ REMOVAL/INSPECTION/ INSTALLATION -----	13- 3
FRONT ASSY CVJ DISASSEMBLY/INSPECTION/ ASSEMBLY -----	13- 5
FRONT GEAR CASE REMOVAL/INSPECTION/INSTALLATION -	13-11
FRONT GEAR CASE DISASSEMBLY/INSPECTION/ASSEMBLY	13-14
REAR ASSY GEAR CASE REMOVAL/INSPECTION/ INSTALLATION -----	13-19

13. DRIVE TRAIN

FRONT GEAR BOX

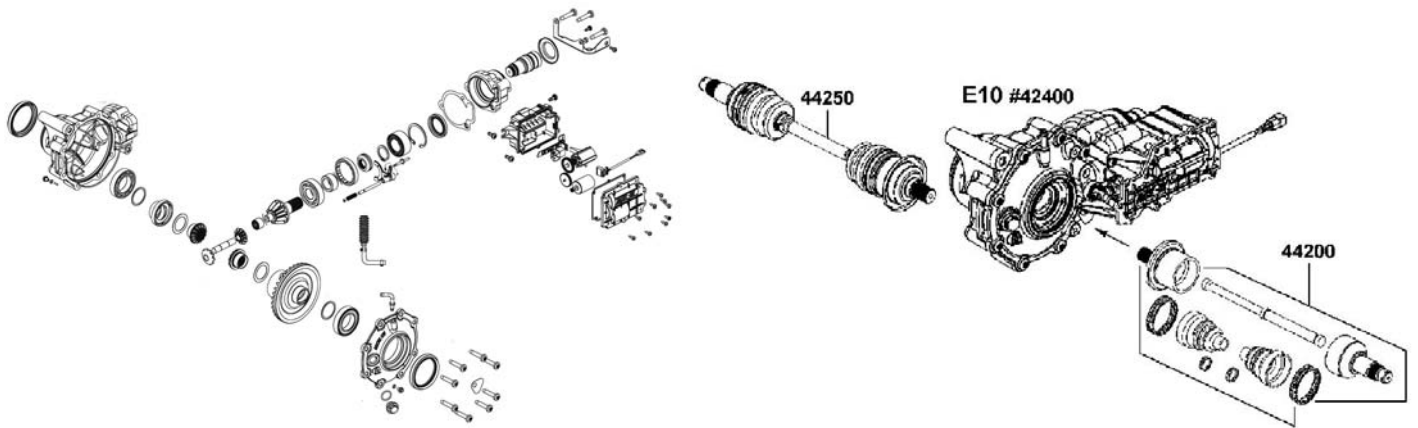

REAR GEAR BOX

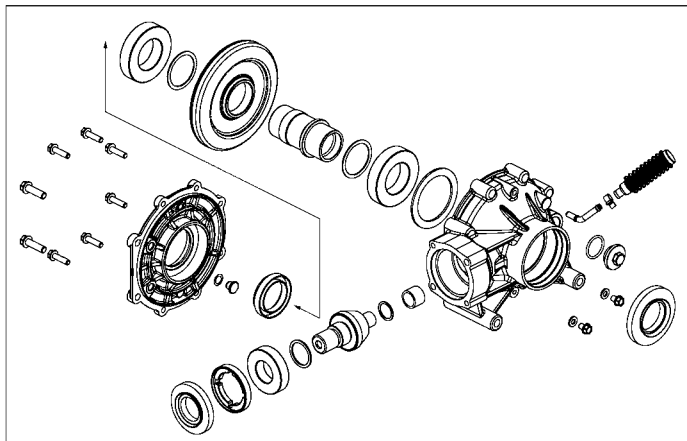

41300

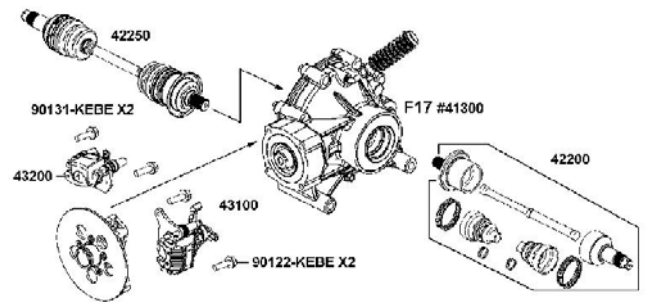

SERVICE INFORMATION

GENERAL INSTRUCTIONS

- Too little backlash is extremely destructive to the gear teeth. If a test ride following reassembly indicates this condition, stop riding immediately to minimize gear damage.
- Stop riding immediately if broken gear teeth are suspected. This condition could result in the shaft drive assembly locking up, causing loss of control of the machine and possible injury to the rider.
- An apparent oil leak on a new or nearly new machine may be the result of a rust-preventative coating or excessive seal lubrication.
- Always clean the machine and recheck the suspected location of an apparent leakage.

TORQUE VALUES

Front drive gear case mounting bolt	4.0 kgf-m (40 Nm, 29 lbf-ft)
Front propeller shaft bolt	4.5 kgf-m (45 N-m, 32.4 lbf-ft)
Shifting fork shaft plug	1.5 kgf-m (15 N-m, 11 lbf-ft) Apply threebond: 1215
Front drive gear case bolt	2.3 kgf-m (23 N-m, 16.5 lbf-ft) Apply threebond: 1215
2WD/4WD shift motor mounting bolt (M8)	2.3 kgf-m (23 N-m, 16.5 lbf-ft) Apply threebond: 1215
2WD/4WD shift motor mounting bolt (M6)	1.2 kgf-m (12 N-m, 8.5 lbf-ft)
Rear drive gear case mounting nut	5.5 kgf-m (55 Nm, 40 lbf-ft)
Rear drive gear case bolt (M10)	5 kgf-m (49 N-m, 36 lbf-ft) Apply threebond: 1215
Rear drive gear case bolt (M8)	2.5 kgf-m (25 N-m, 19 lbf-ft) Apply threebond: 1215

SPECIAL TOOLS

Oil seal & bearing installer	A120E00014
Bearing puller	A120E00037
Pinion gear puller	A120F00026
Bearing lock nut wrench	A120F00020/25

TROUBLESHOOTING

- 1. A pronounced hesitation movement during acceleration, deceleration, or sustained speed. (This must not be confused with engine surging or transmission characteristics.)**
- 2. A “rolling rumble” noticeable at low speed; a high-pitched whine from front drive component or area.**
- 3. A locked-up condition of the shaft drive train mechanism, no power transmitted from the engine to the front and /or rear wheel.**
 - Bearing damage
 - Improper backlash
 - Gear tooth damage
 - Broken propeller shaft
 - Broken gear teeth
 - Seizure due to lack of lubrication
 - Small foreign objects lodged between the moving parts.

FRONT CVJ ASSY REOMVAL/INSPECTION/ INSTALLATION

REMOVAL

Remove the steering knuckle

Remove the front cvj assy from front assy gearcase.

SIEP 1: Drain gear oil

SIEP 2: Pushing and pulling the front assy cvj from front assy gearcase.

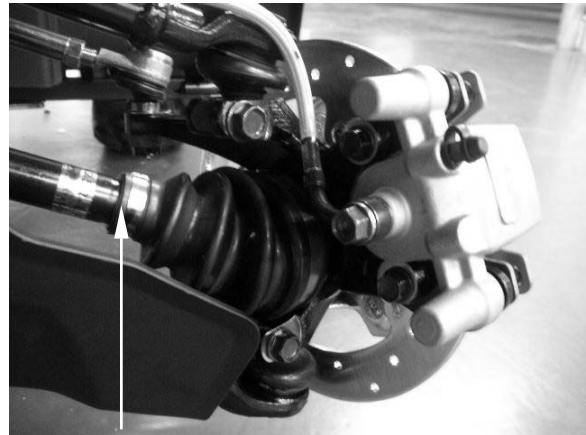

Front Cvj Assy

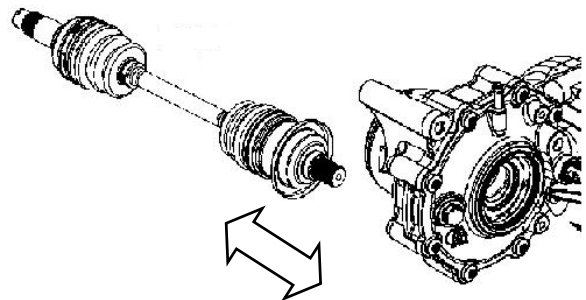

INSPECTION

Inspect the boots, circlip and boot bands for wear or damage.

If any damages are found, replace them with new ones.

Inspect the double off-set joint spline for wear or damage.

If any damages are found, replace them with new ones.

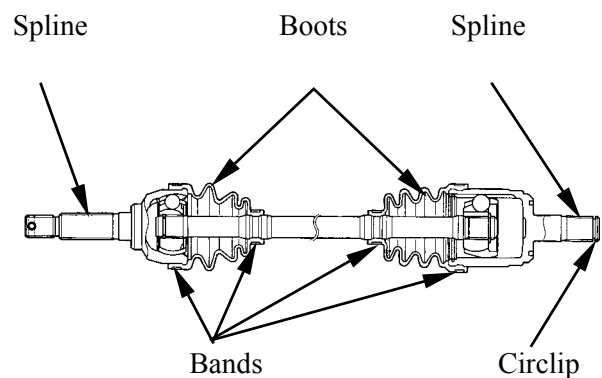

Inspect the free play by using a push-and-pull motion (thrust movement).
Excessive play → Replace the joint assembly.

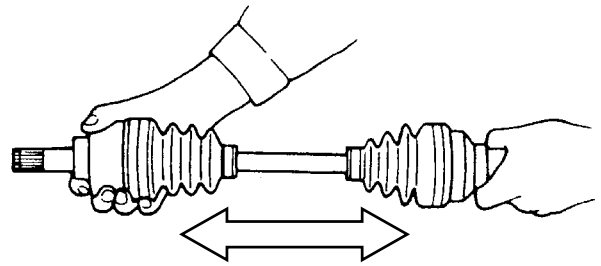

INSTALLATION

Install a new circlip into its groove in the splines.

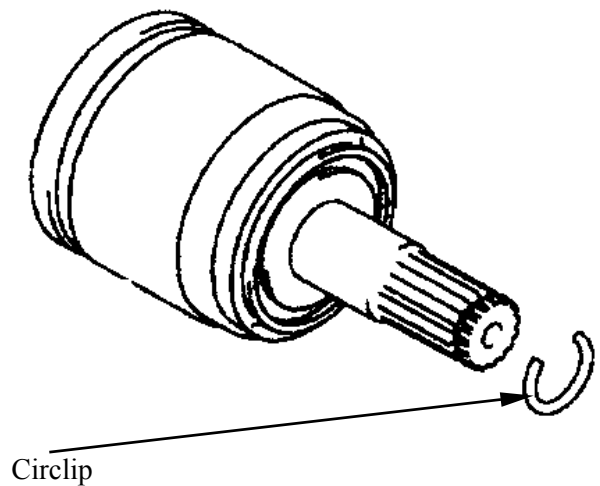

Apply lightweight lithium-soap base grease to the splines of the drive shafts and install the cvj to the front assy gearcase.

*

- Be careful not to damage the oil seal in the front assy gear case.
- After installing cvj, check the circlip is seated properly by pulling the case side joint lightly.

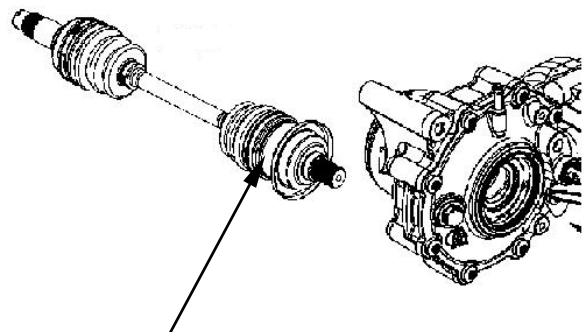

Case Side Joint

FRONT DRIVE AXLE DISASSEMBLY/INSPECTION/ ASSEMBLY

DISASSEMBLY

Remove the front drive axle

Remove the boot band of the case side joint.

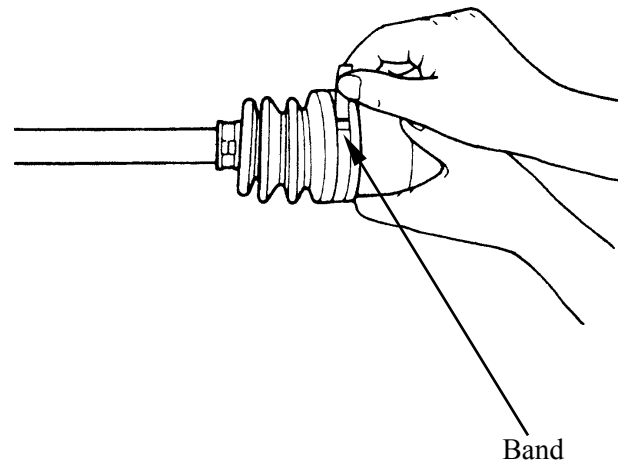

Slide the boot toward the center of the front cvj assy and remove the circlip from the case side joint.

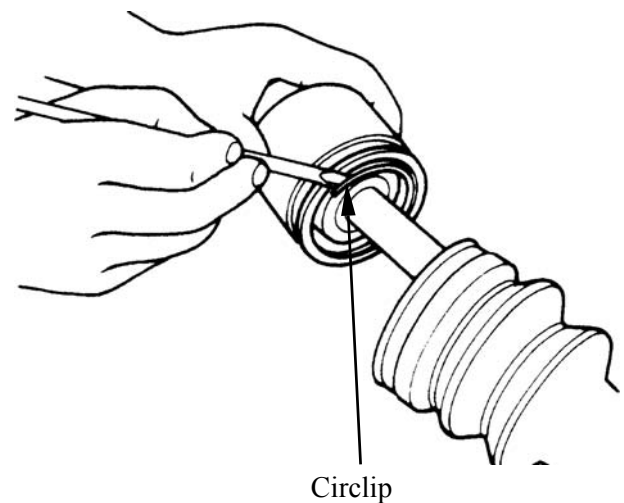

Separate the case side joint from the front cvj assy

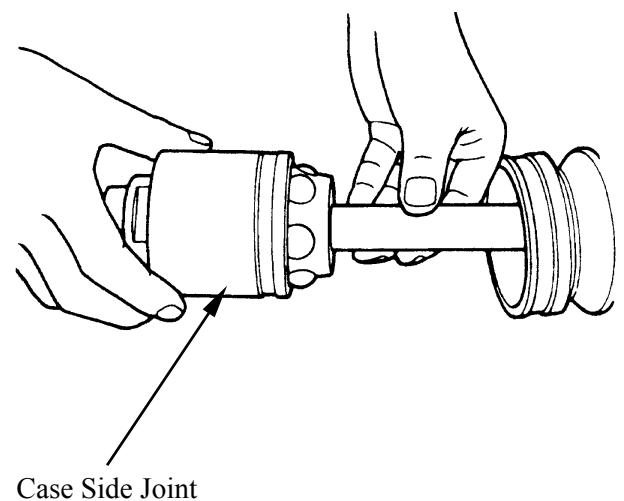

Wipe off any grease and remove the snap ring from the groove on the front drive axle.

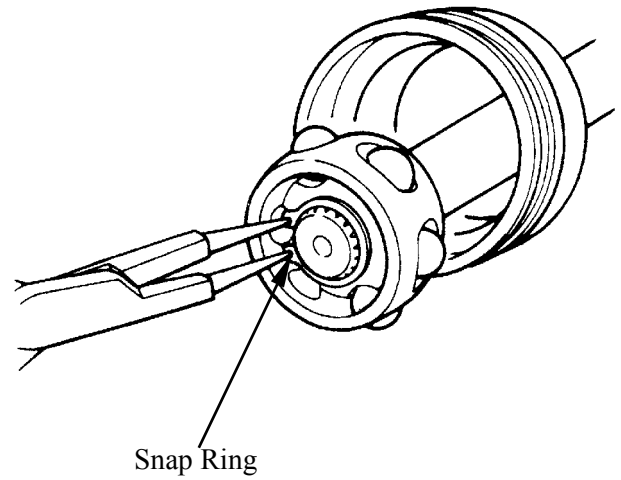

Remove the cage and boot from the front assy cvjs.

* Do not disassemble the wheel side joint. If any damages are found, replace the wheel side joint with a new one.

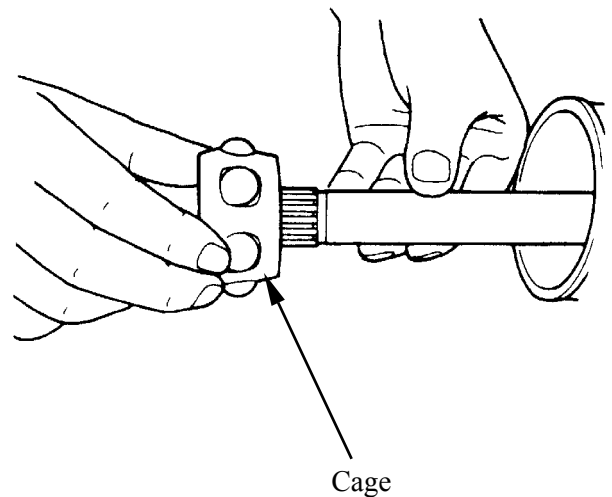

INSPECTION

Inspect the circlip and snap ring for wear or damage.

If any damages are found, replace them with new ones.

Inspect the cage and inner surface of case side joint for pitting, wear or damage.

If any damages are found, replace them with new ones.

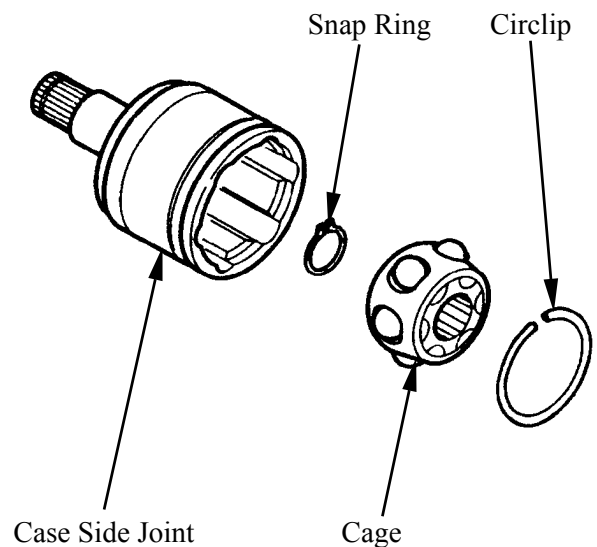

13. DRIVE TRAIN

Inspect the front cvj assy spline for wear or damage.
If any damages are found, replace them with a new one.
Inspect the front cvj assy for bends.
If any damages are found, replace them with a new one.

* Do not attempt to straighten a bent shaft; this may dangerously weaken the shaft.

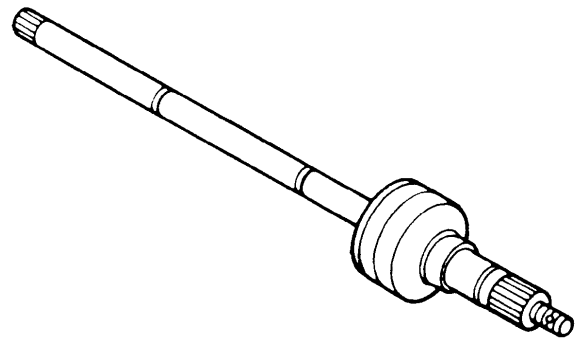

ASSEMBLY

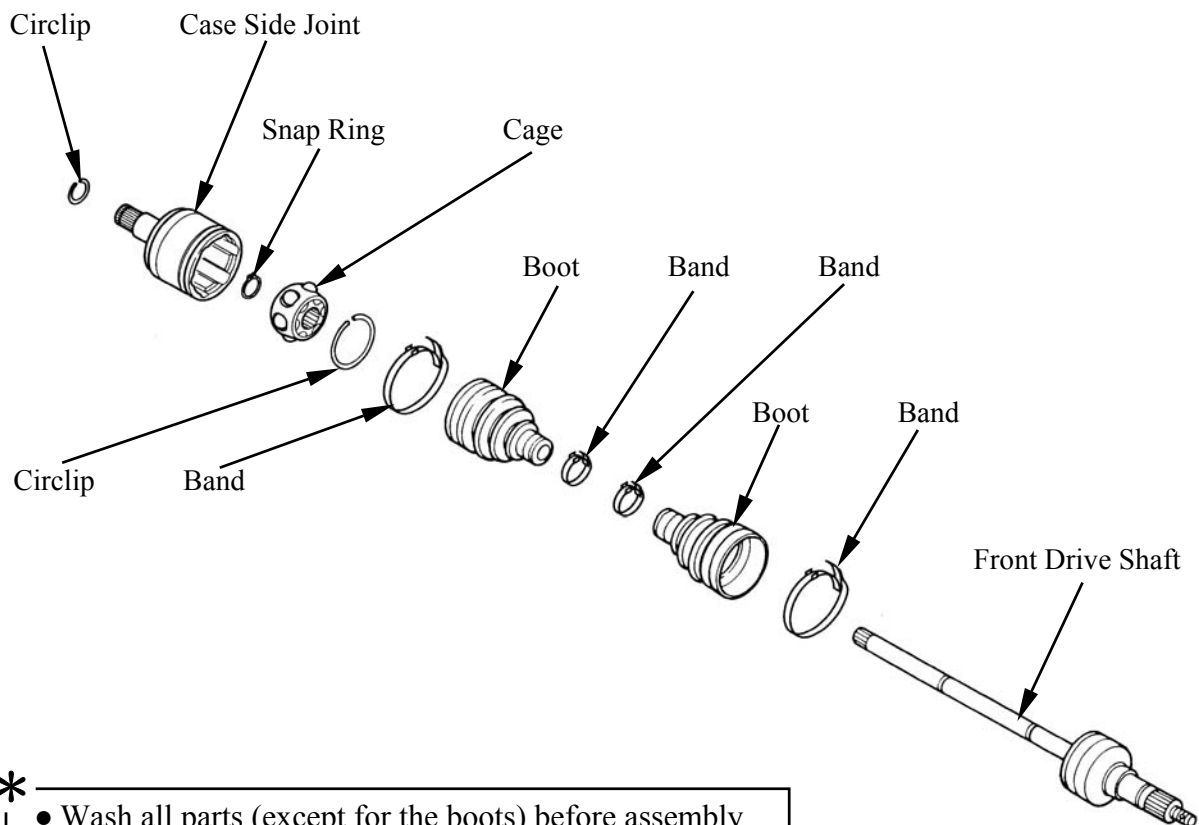

*
• Wash all parts (except for the boots) before assembly, clean the inside and outside of the boot with a cloth.
• Do not wash the boots in any commercially available degreaser, such as gasoline or kerosene. Washing in a degreaser causes deterioration of the boot.

13. DRIVE TRAIN

Fit a boot on the drive shaft end, fitting the small diameter side of the boot to the shaft groove, fix its end with a new band.

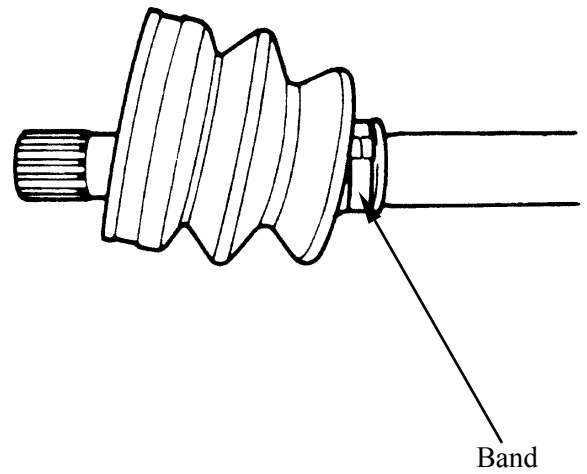

Install the cage on the shaft.

* Install the cage with the large diameter side facing the shaft end.

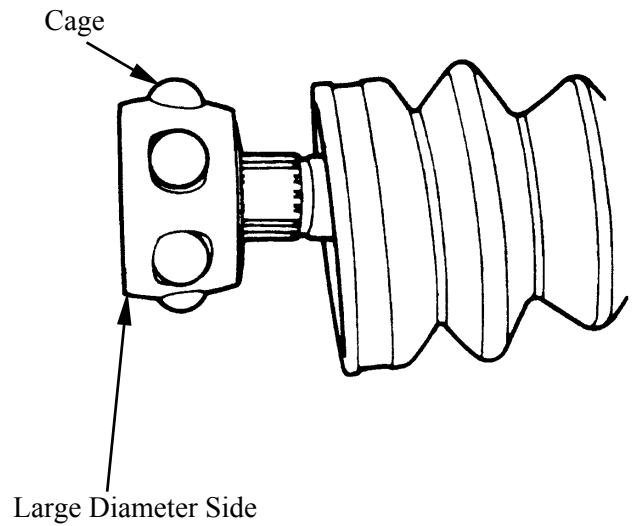

Install the snap ring to the groove on the drive shaft.

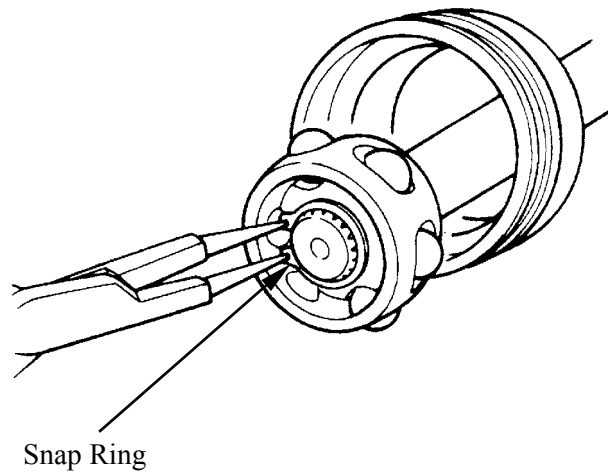

13. DRIVE TRAIN

Apply molybdenum disulfide grease to the entire surface of the cage and the inside of the case side joint/wheel side joint.

Position Grease	Case side joint	Wheel side joint
Quantity	85 g (2.8 oz)	45 g (1.5 oz)

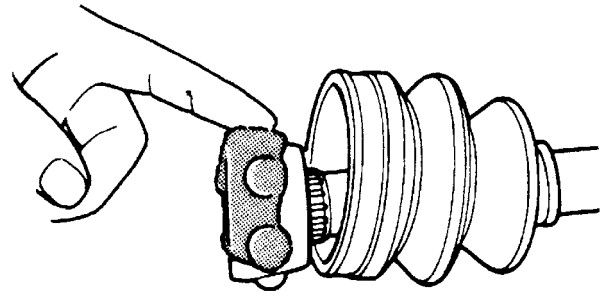

* The tube of joint molybdenum disulfide grease is included in the wheel side boot set or wheel side joint assembly of spare parts.

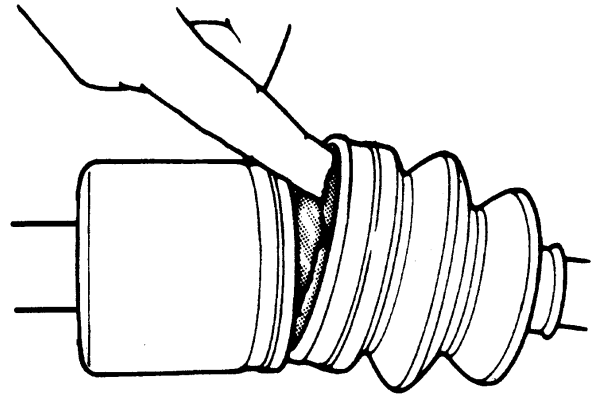

Insert the cage into the case side joint and fit a circlip in the groove of the case side joint.

* Locate the opening of the circlip so that the opening is not lined up with a ball.

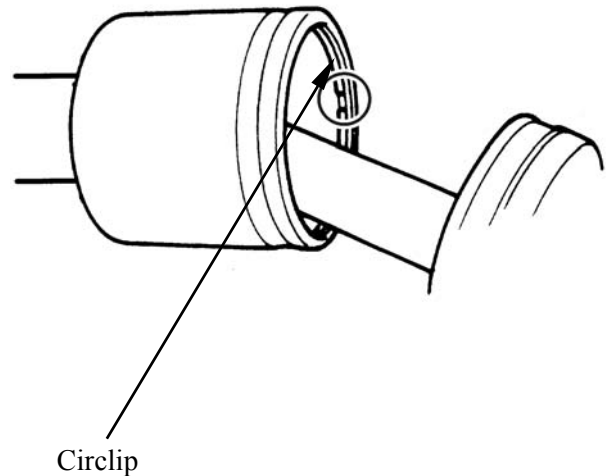

13. DRIVE TRAIN

After fitting the boot on the case side joint, insert a screw driver into the boot on the case side joint and allow air to enter the boot so that the air pressure in the boot becomes the same as the atmospheric pressure.

Fix the boot on the case side joint with a new boot band, taking care not to distort the boot.

*

The dust boots should be fastened with the boot bands at the grooves in the drive shaft.

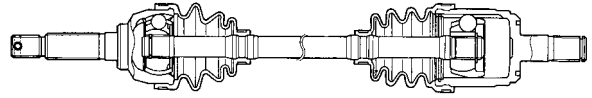

13. DRIVE TRAIN

FRONT ASSY GEARCASE REMOVAL/INSPECTION/ INSTALLATION

REMOVAL

Drain the front assy gearcase oil (refer to the “**FRONT DRIVE GEAR OIL**” in the chapter 3).

Remove the steering knuckle (refer to the “**STEERING KNUCKLE REMOVAL/INSPECTION/INSTALLATION**” section in the chapter 14).

Remove the front upper arms and front lower arms (refer to the “**FRONT ARMS INSPECTION/REMOVAL/INSTALLATION**” section in the chapter 14).

Remove the drive shafts (refer to the “**FRONT DRIVE SHAFT REOMVAL/INSPECTION/INSTALLATION**” section in this chapter).

Disconnect the following wire connectors



13. DRIVE TRAIN

Remove the shaft input from front propeller shaft.

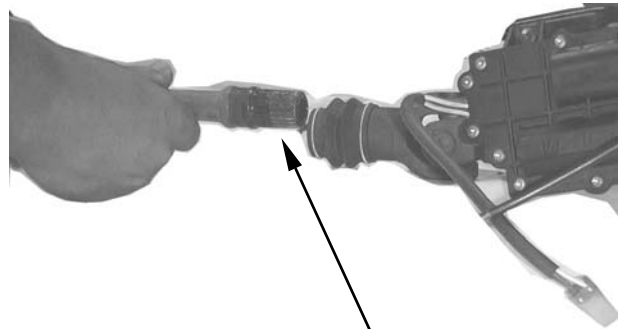

Front Propeller Shaft

Remove front gear case mounting bolts/nuts from frame, then remove the case out of the frame.

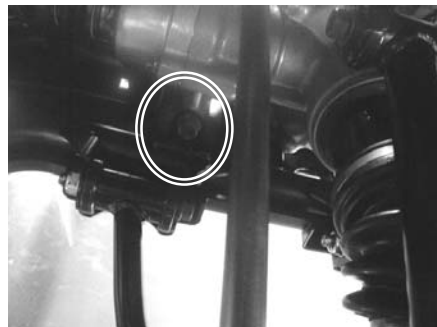
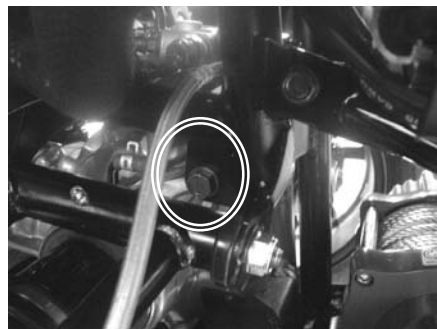

INSPECTION

Check the breather rubber case for wear or damage. Also, check that the joint of the rubber case fits tightly.

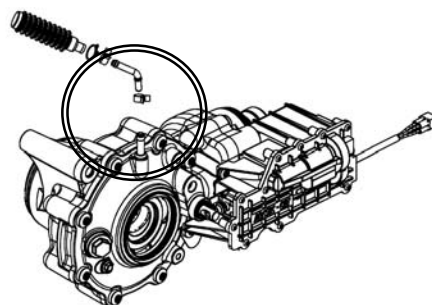

13. DRIVE TRAIN

INSTALLATION

Install the front drive case into the frame.

Install and tighten the two mounting bolts/nuts to the specified torque.

Torque: 4 kgf-m (40 N-m, 29 lbf-ft)

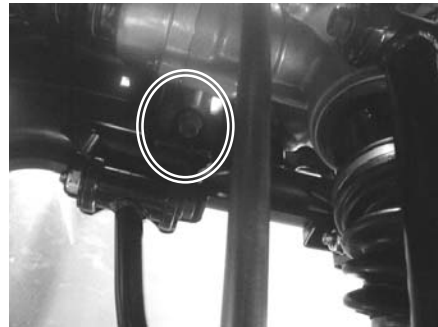
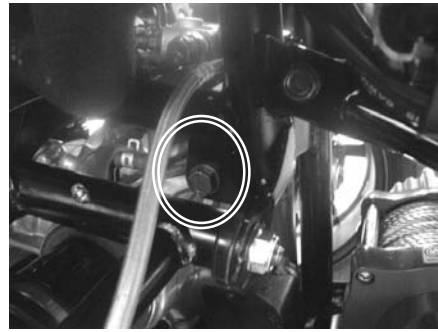

Install the front propeller shaft.

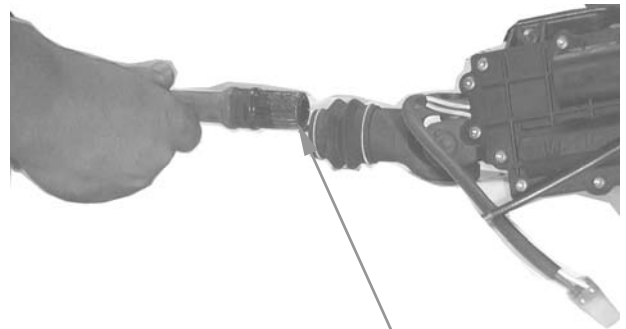

Front Propeller Shaft

Connect all wire connectors and then install.



13. DRIVE TRAIN

FRONT ASSY GEAR CASE DISASSEMBLY/INSPECTION/ ASSEMBLY

Remove the front drive case assembly

Remove the 3 bolts and then remove the
2WD/4WD shifting motor assembly.

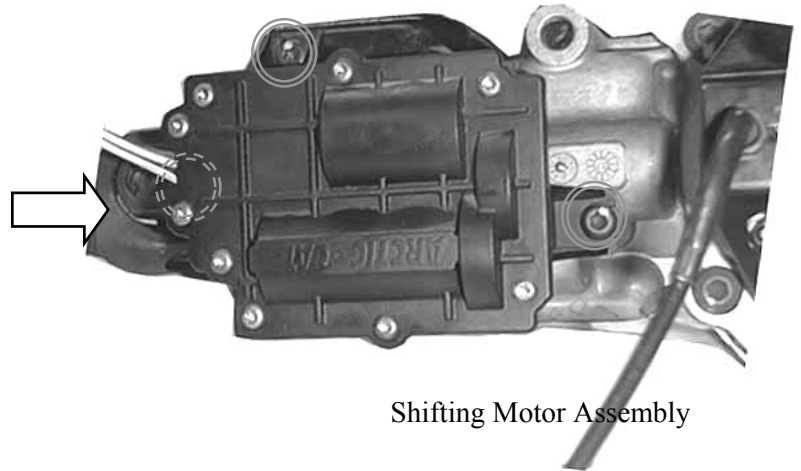

Shifting Motor Assembly

Remove the differential lock lever wire.
From front gear case.

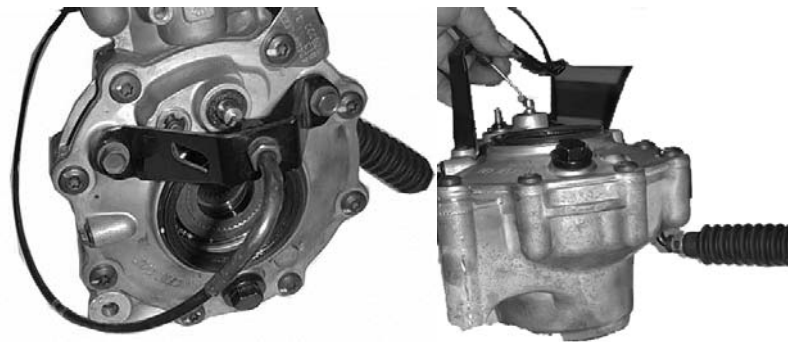

Remove the 3 bolts from housing pinion
Disconnect the housing pinion



13. DRIVE TRAIN

Remove the clip from shaft input
Disconnect the shaft input

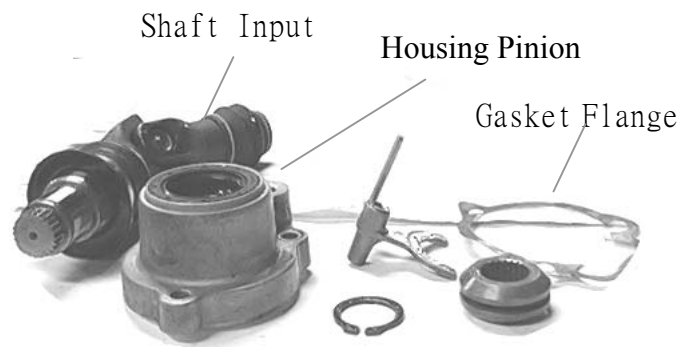
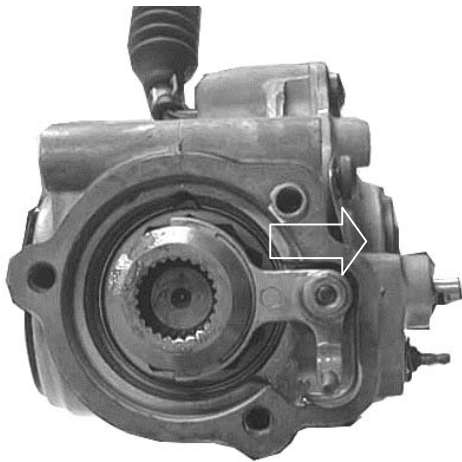

Remove the 8 bolts from the front assy
Gear case .
Disconnect the cover machined



13. DRIVE TRAIN

Remove front gear ring from gear case

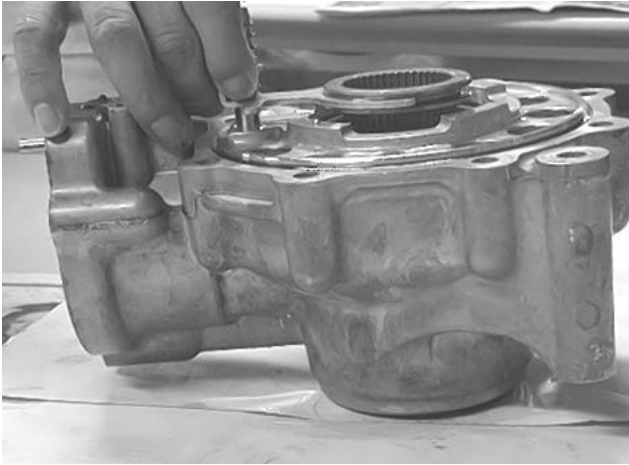

Using the 48mm internal Hex Socket
Into the housing gear case
Disconnect the front gear ring

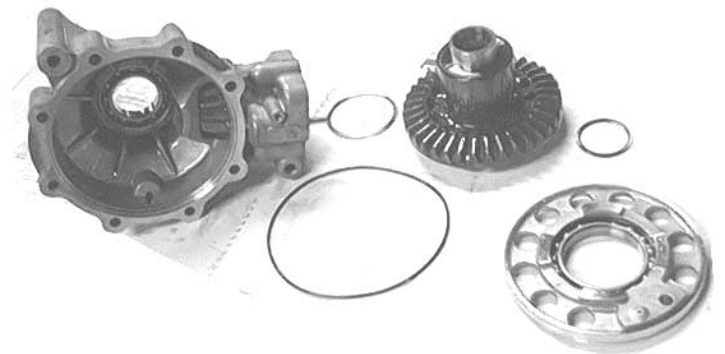
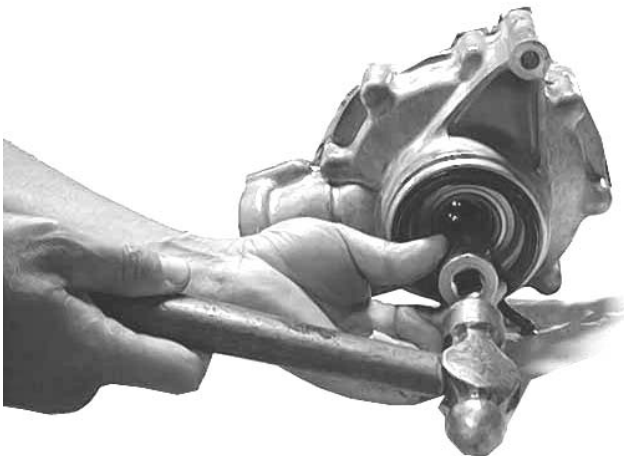

13. DRIVE TRAIN

Using the **SPECIAL TOOL:A120F00025**
And hammer./screwdriver Remove the
pinion gear from the gear case housing.

Tighten to 125 ft-lb



SPECIAL TOOL:A120F00025

SPECIAL TOOL:A120F00025

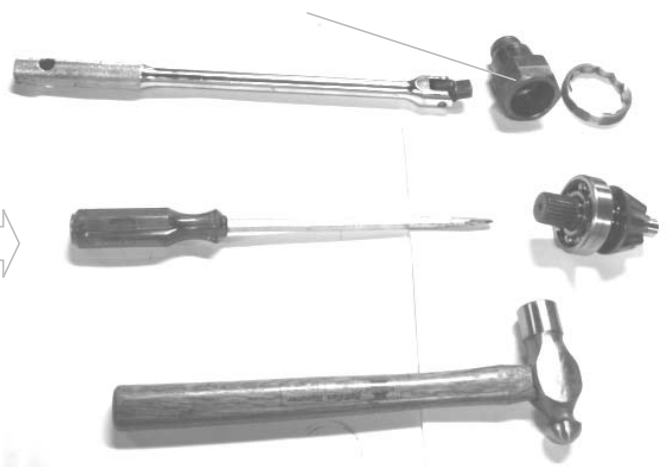
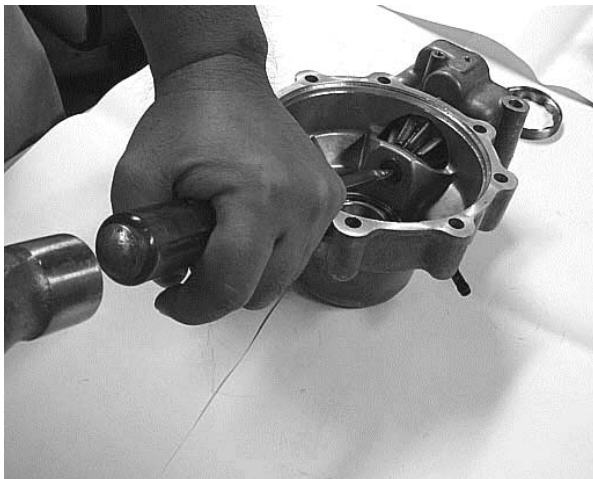

Secure the pinion gear in a bearing puller.
Then remove the pinion bearing using a
press. Account for a collar and a bearing.



13. DRIVE TRAIN

Remove Needle Bearing

Using the hammer./screwdriver Remove the Needle bearing.



Remove and Installing Axle Bearing

Using a hammer./tool Remove the bearing.



Using a hammer./tool installing new bearing. Into the housing.

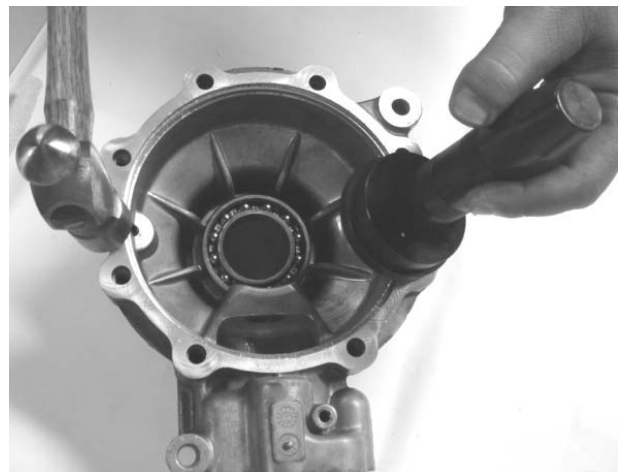
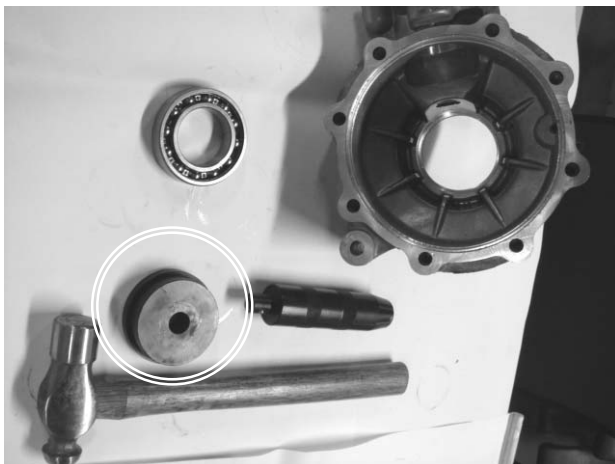

REAR ASSY GEAR CASE REMOVAL/INSPECTION/ INSTALLATION

REMOVAL

Remove the left rear axle housing

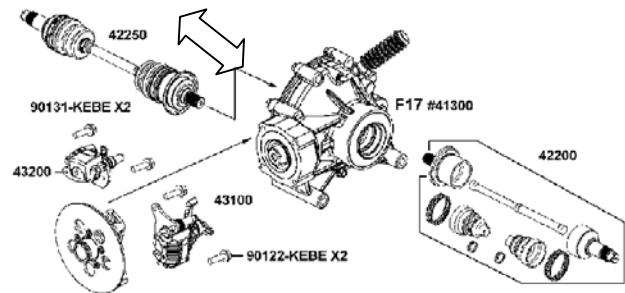

Remove the cvj assy right rear using
Suitable tools.

Using hammer remove the cvj assy left
rear

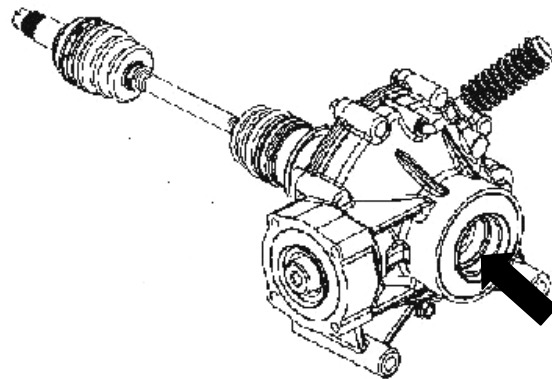

13. DRIVE TRAIN

Remove rear gear case mounting bolts/nuts from frame, then remove the case out of the frame.

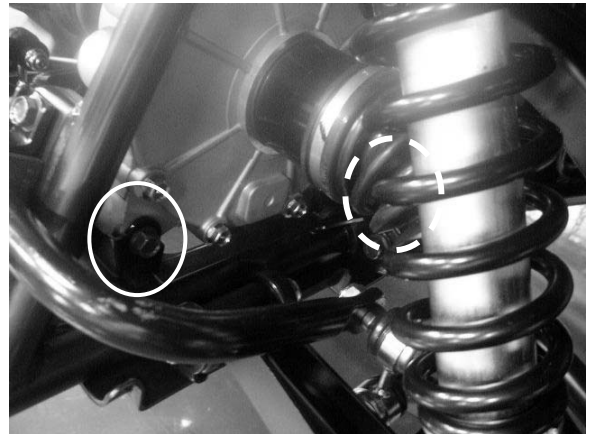

Remove 1 bolt from holder disc rear brake, then remove the holder disc rear brake

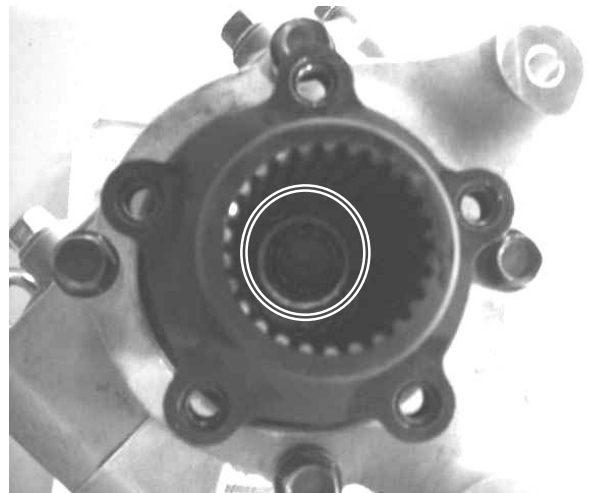

Remove 4 bolts from bracket caliper, then remove the bracket caliper

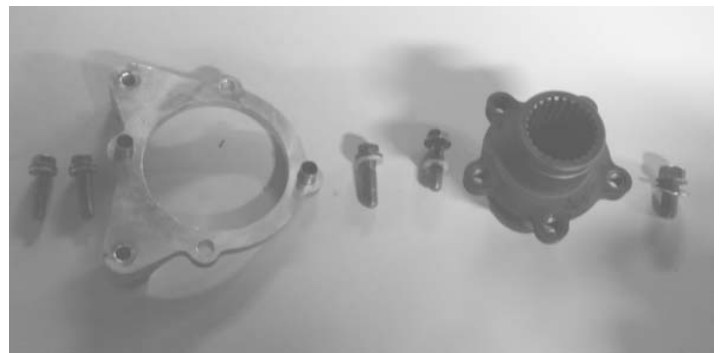
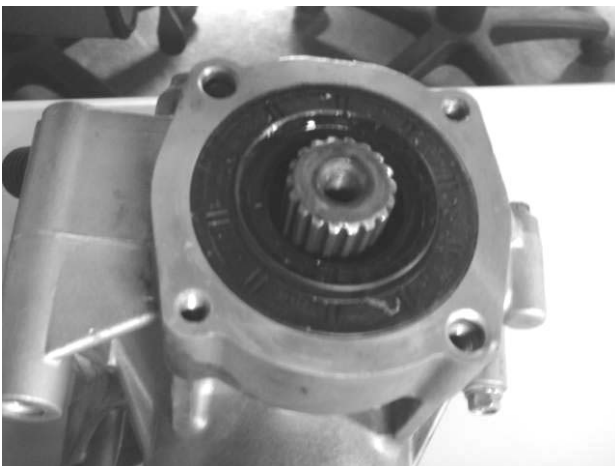

13. DRIVE TRAIN

Remove seven bolts from R side case rear final, then remove R side case rear final

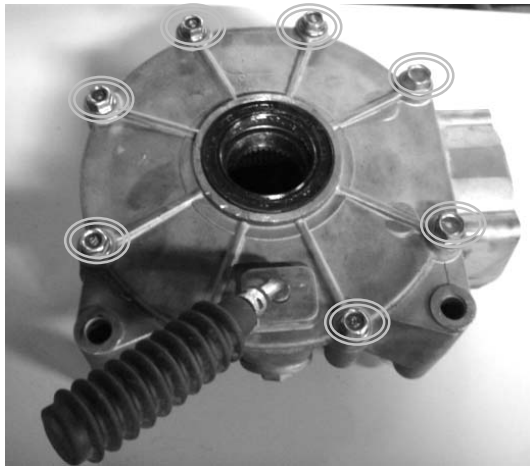

L side case rear

Gear Ring

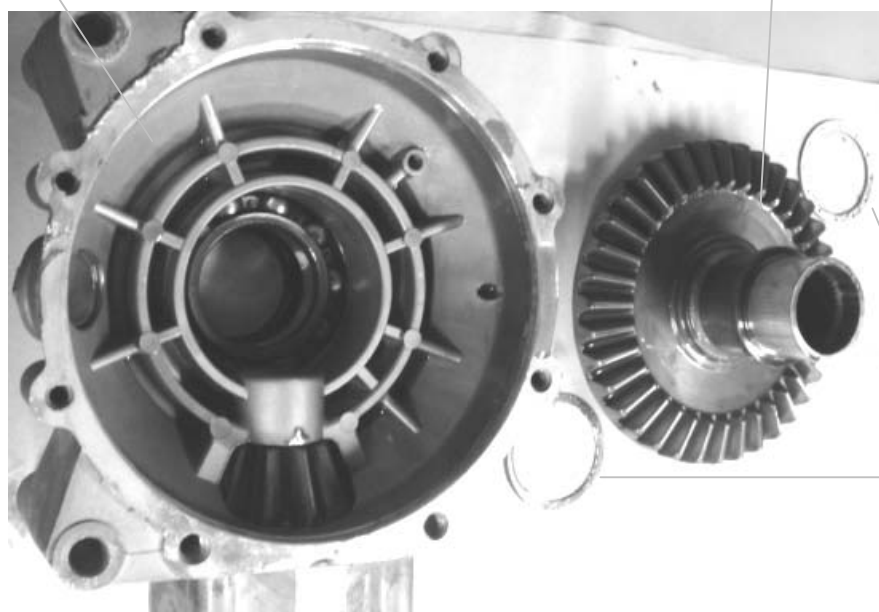

Shim Ring Gear

13. DRIVE TRAIN

Remove the bearing lock nut by using special tool.

Special tool:

Bearing lock nut wrench A120F00020



Using the **SPECIAL TOOL:A120F00026**

Remove the pinion gear from the gear case housing.

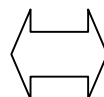
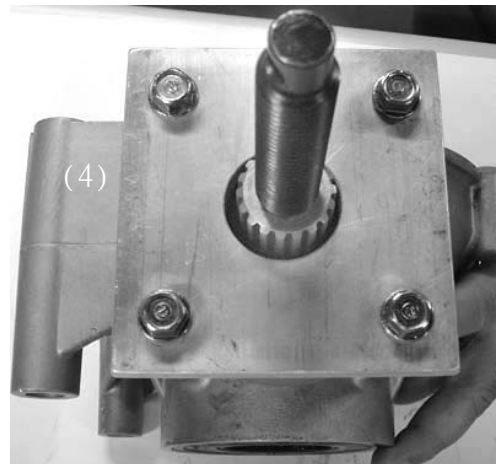
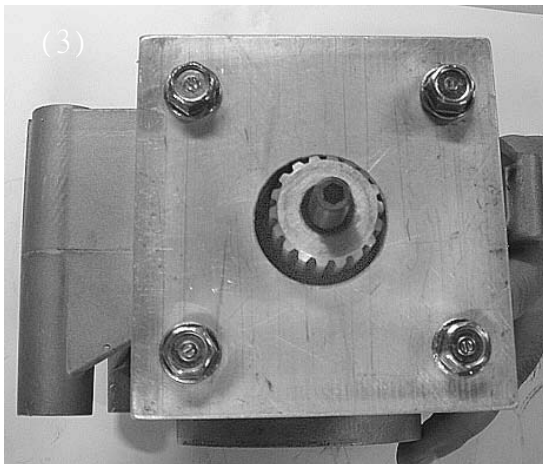
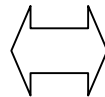
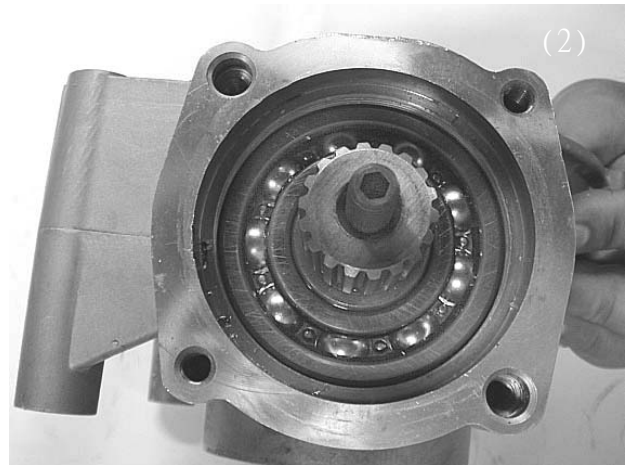
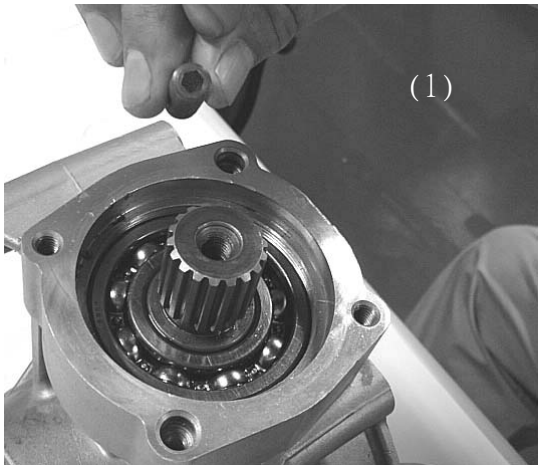

13. DRIVE TRAIN

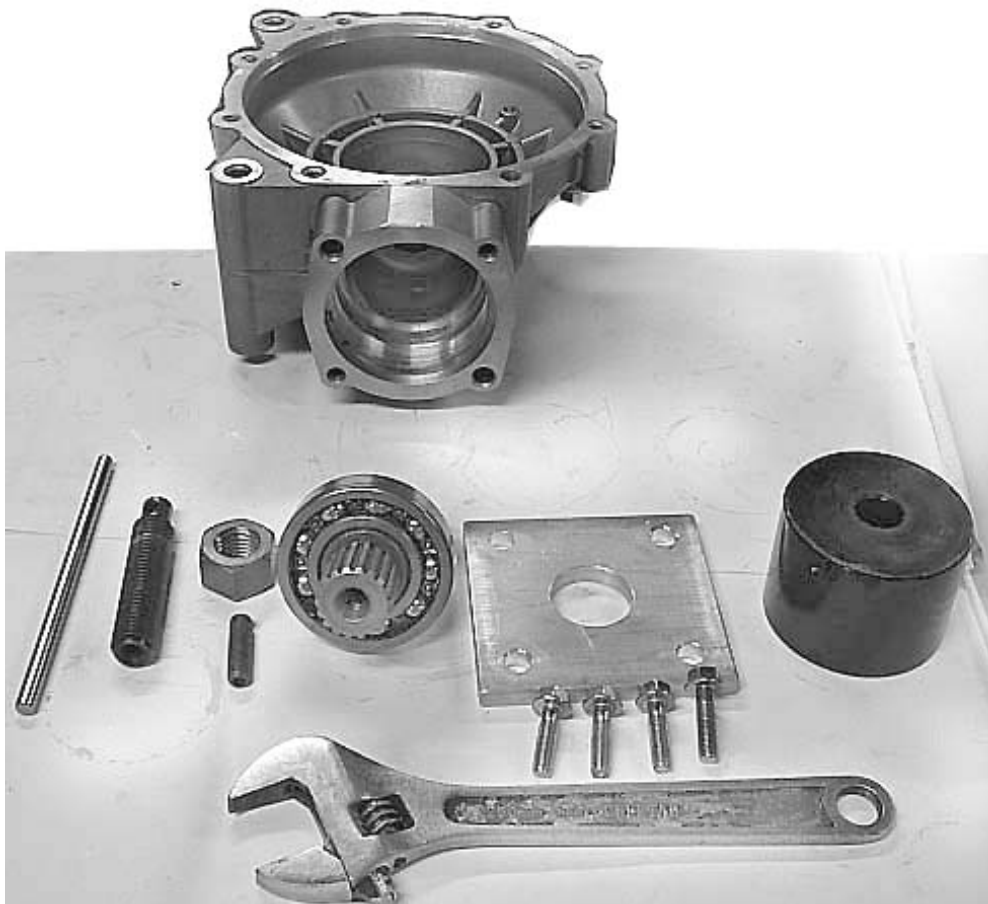
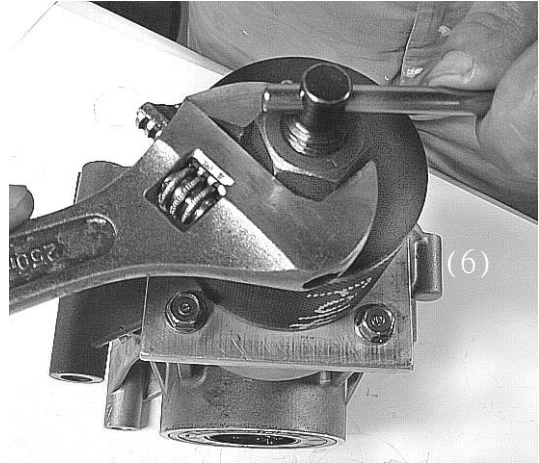
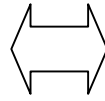
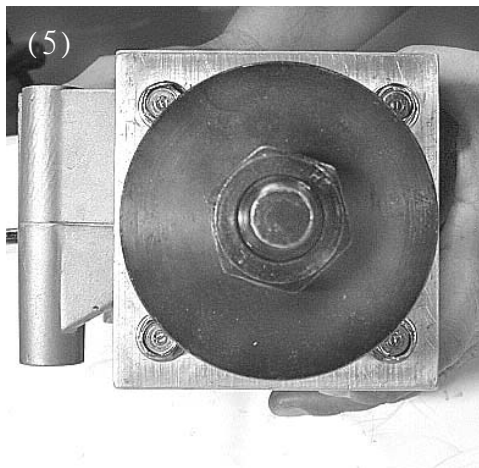

SPECIAL TOOL:A120F00026

13. DRIVE TRAIN

Secure the pinion gear in a bearing puller.
Then remove the pinion bearing using a press. Account for a collar and a bearing.

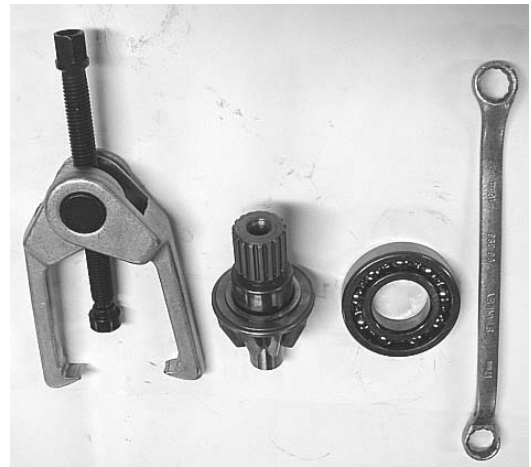
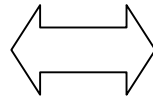

Remove the needle bearing.
by using the special tools.

Special tool:

Bearing puller A120E00037

Needle Bearing

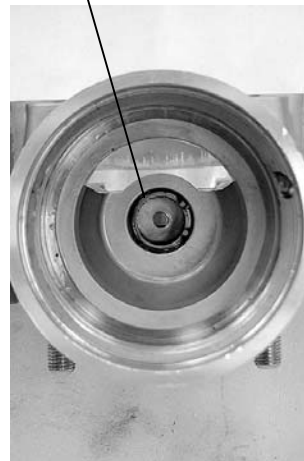

**FRONT WHEEL/FRONT SUSPENSION STEERING
SYSTEM**

SERVICE INFORMATION-----	14- 2
TROUBLESHOOTING-----	14- 3
FRONT WHEEL REMOVAL/INSPECTION/INSTALLATION ----	14- 4
FRONT WHEEL HUB REMOVAL/INSPECTION/ INSTALLATION -----	14- 5
FRONT SHOCK ABSORBER REMOVAL/INSPECTION/ INSTALLATION -----	14- 7
STEERING KNUCKLE REMOVAL/INSPECTION/ INSTALLATION -----	14- 8
HANDLEBAR REMOVAL/INSPECTION/INSTALLATION -----	14- 15
STEERING COLUMN REMOVAL/INSPECTION/INSTALLATION -----	14- 19

14. FRONT WHEEL/FRONT SUSPENSION STEERING SYSTEM

KYMCO
MXU550EXi/MXU500i

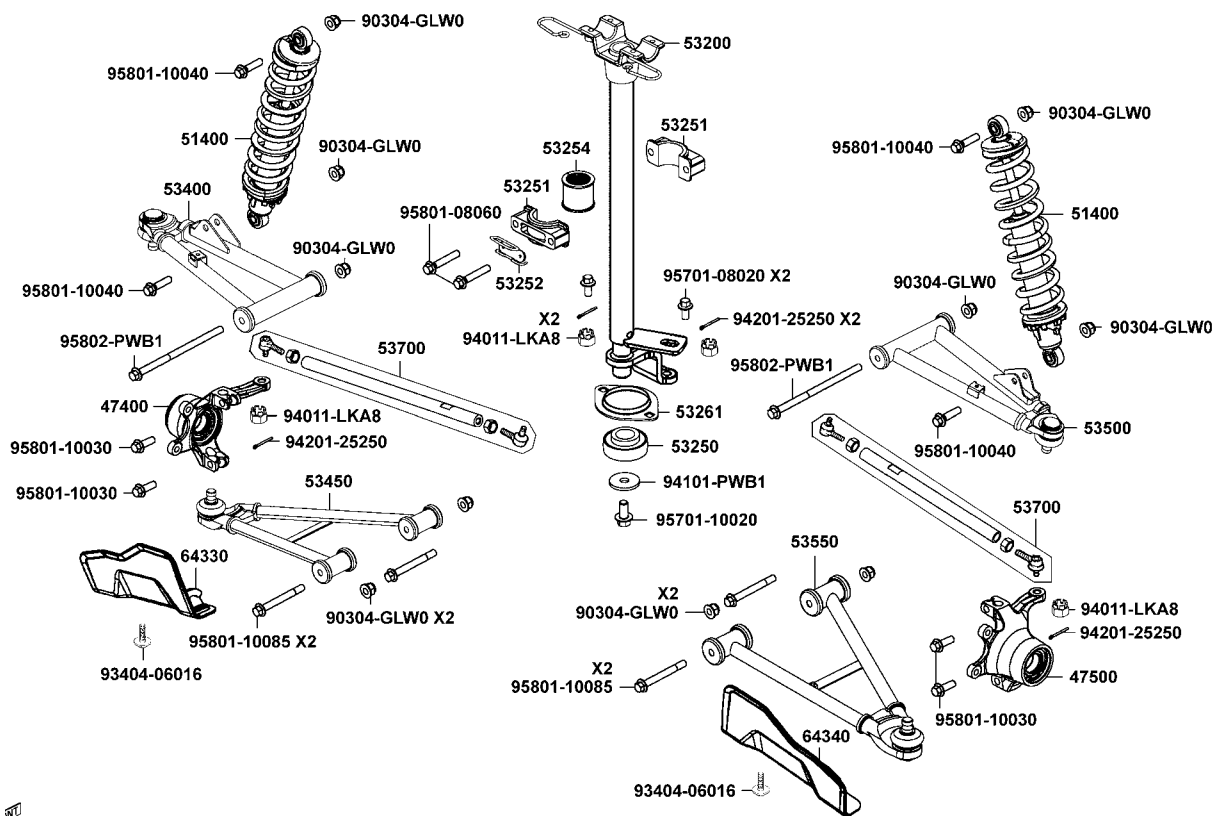
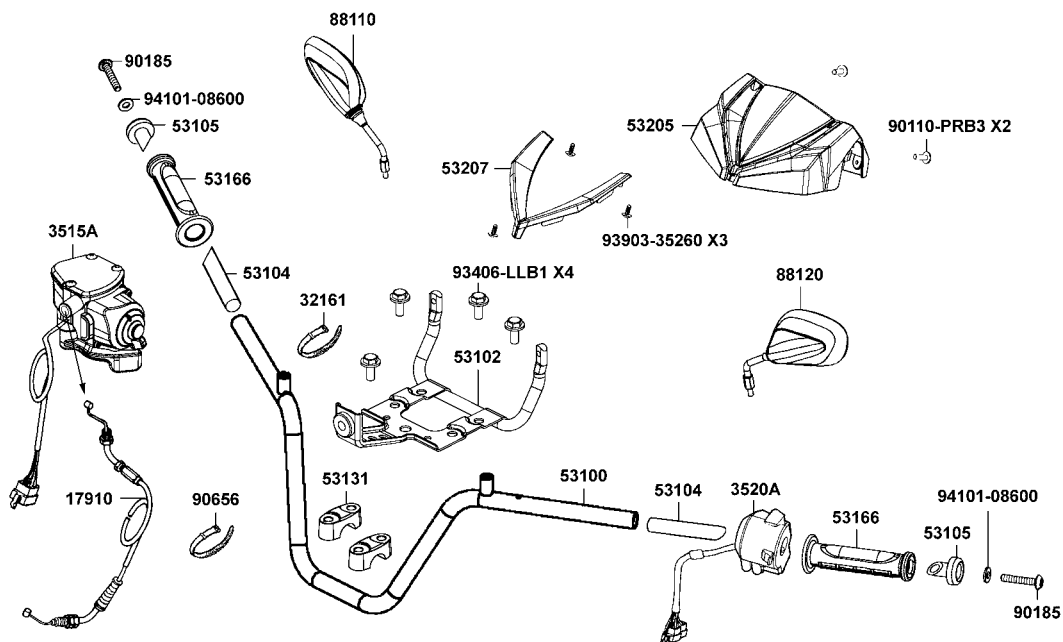

14. FRONT WHEEL/FRONT SUSPENSION/ STEERING SYSTEM

 **KYMCO**
MXU550EXi/MXU500i

SERVICE INFORMATION

GENERAL INSTRUCTIONS

- Jack the machine front wheel off the ground and be careful to prevent the machine from falling down.
- During servicing, keep oil or grease off the brake disk
- Inspect the brake system before riding.

SPECIFICATIONS

Unit: mm (in)

Item		Standard	Service Limit
Front wheel rim run out	Radial	—	2 (0.08)
	Axial	—	2 (0.08)
Toe in		0~15mm(0~0.59)	—
			—

TORQUE VALUES

Handlebar and steering post	2.7 kgf-m (27 N-m, 19 lbf-ft)
Upper/lower housing and frame.	2.7 kgf-m (27 N-m, 19 lbf-ft)
Steering knuckle and tie-rod	4.2 kgf-m (42 N-m, 30lbf-ft)
Steering stem and tie-rod	4.2 kgf-m (42 N-m, 30lbf-ft)
Tie-rod lock nut	2.5kgf-m (25 N-m, 18lbf-ft)
Steering post lower pivot	2.5kgf-m (25 N-m, 18lbf-ft)
Front wheel hub and front Halfshaft(CVJ)	28 kgf-m (280 N-m, 201lbf-ft)
Front shock absorber mount bolt	4.8 kgf-m (48 N-m, 35 lbf-ft)
Front wheel nut	6.1 kgf-m (61 N-m, 44 lbf-ft)

SPECIAL TOOLS

Oil seal and bearing driver A120E00014

14. FRONT WHEEL/FRONT SUSPENSION STEERING SYSTEM

TROUBLESHOOTING

Hard steering (heavy)

- Insufficient tire pressure

Steers to one side or does not track straight

- Uneven front shock absorbers
- Bent front arm
- Bent steering knuckle

Front shock absorber noise

- Slider bending
- Loose arm fasteners
- Lack of lubrication

Front wheel wobbling

- Bent rim
- Excessive wheel bearing play
- Bent spoke plate
- Faulty tire
- Improperly tightened axle nut

Soft front shock absorber

- Weak shock springs
- Insufficient damper oil

14. FRONT WHEEL/FRONT SUSPENSION/ STEERING SYSTEM

 **KYMCO**
MXU550EXi/MXU500i

FRONT WHEEL REMOVAL/INSPECTION/ INSTALLATION

REMOVAL

Place the machine on a level place.
Remove four nuts from front wheel.

Elevate the front wheels by placing a
suitable stand under the frame.

* Support the machine securely so there is
no danger of it falling over.

Remove the wheel and wheel hub nut cap
together.



Wheel Hub Nut Cap

INSPECTION

Measure the wheel run out.
Replace wheel or check bearing play if out
of specification

Rim run out limits:

Vertical: 2 mm (0.08 in)

Lateral: 2 mm (0.08 in)

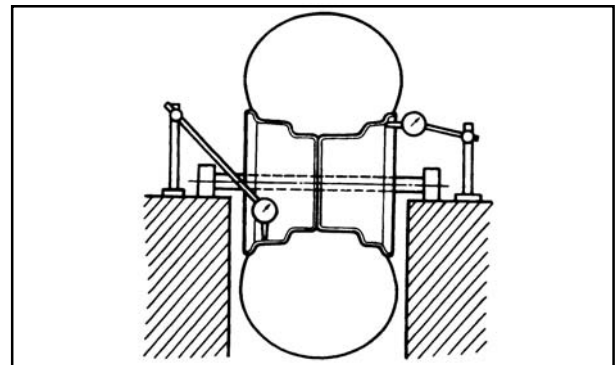

INSTALLATION

When reinstalling a wheel, tighten the
wheel nuts in a crisscross (rather than a
circular) pattern.

Torque: 6.1kgf-m (61 N-m)

* Be sure the tapered side of the wheel nuts
face the wheel rim.

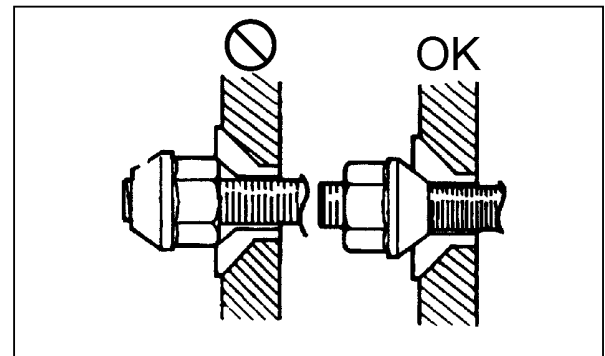

14. FRONT WHEEL/FRONT SUSPENSION STEERING SYSTEM

FRONT WHEEL HUB REMOVAL/INSPECTION/ INSTALLATION

REMOVAL

Place the machine on a level place.
Remove the front wheel (refer to the
“**FRONT WHEEL
REMOVAL/INSPECTION/
INSTALLATION**” section in this chapter)
Elevate the front wheels by placing a
suitable stand under the frame.

*** Support the machine securely so there
is no danger of it falling over.**

Remove the cotter pin.

Apply the front brake and then remove nut,
washer and front wheel hub.

INSPECTION

Check the wheel hub for cracks or deamage.
Check the wheel hub splines for wear or
damage.

Nut/Washer

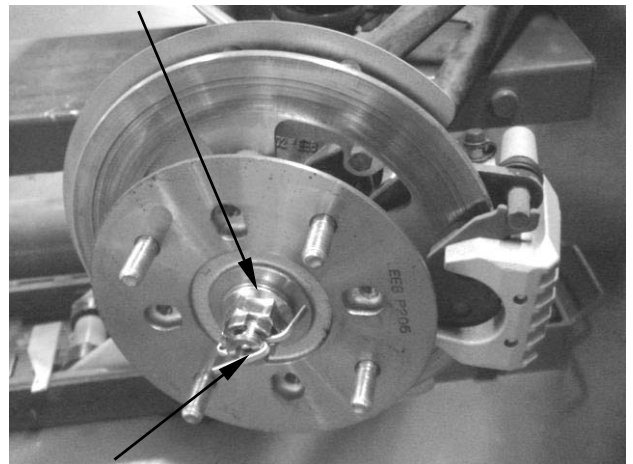

Cotter Pin

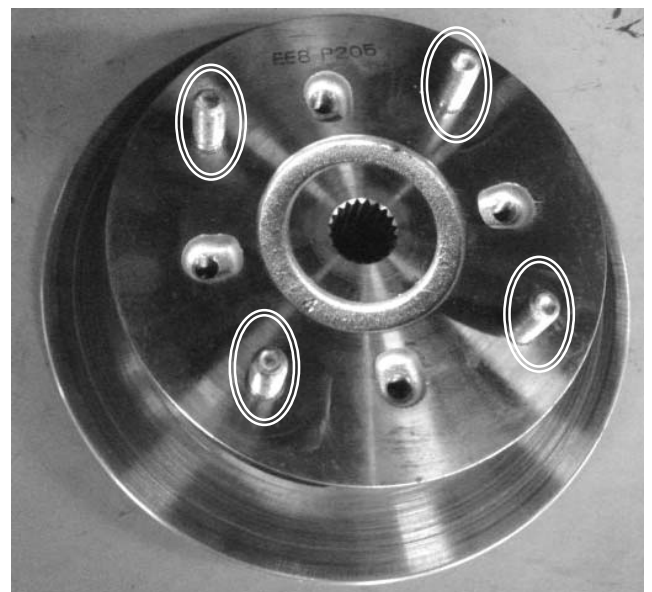

14. FRONT WHEEL/FRONT SUSPENSION/ STEERING SYSTEM

 **KYMCO**
MXU550EXi/MXU500i

INSTALLATION

Install the wheel hub, washer and nut.

- * Apply grease onto the wheel hub splines.

Apply the front brake and then tighten the nut to the specified torque.

Torque: 7 kgf-m (70 N-m, 50 lbf-ft)

Install the cotter pin and band ends of cotter pin.

Nut/Washer

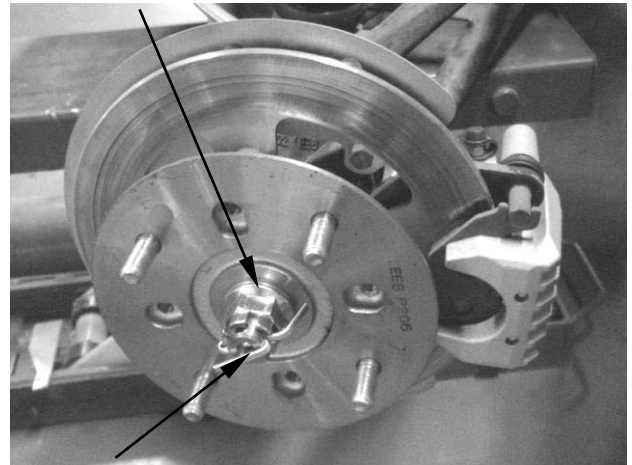

Cotter Pin

- *
 - Do not apply oil to the seat of the nut.
 - Do not loosen the wheel hub nut after torque tightening. If the wheel hub nut groove is not aligned with the cotter pin hole, align groove with the hole by tightening up on the wheel hub nut.

- * Always use a new cotter pin.

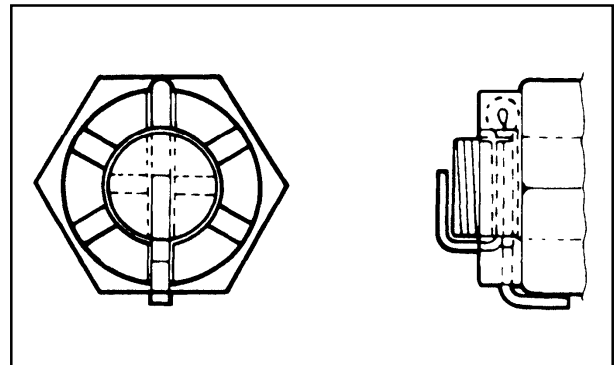

14. FRONT WHEEL/FRONT SUSPENSION STEERING SYSTEM

FRONT SHOCK ABSORBER REMOVAL/INSPECTION/ INSTALLATION

REMOVAL

Remove the front shock absorber upper mount and lower mount bolts/nuts, then remove the front shock absorber.

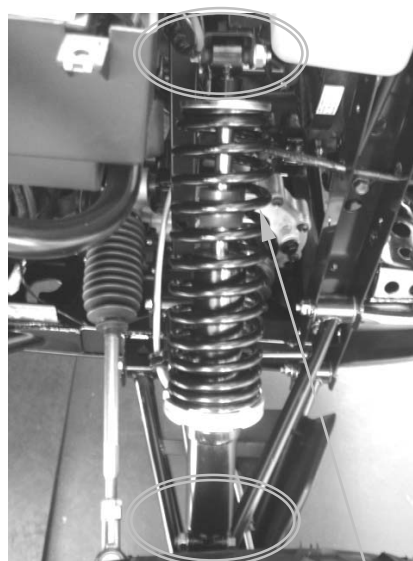

Shock Absorber

INSPECTION

Inspect the shock absorber rod.
Bends/damage → Replace the shock absorber assembly.
Inspect the shock absorber.
Oil leaks → Replace the shock absorber assembly.
Inspect the spring of the shock absorber by move the spring up and down.
Fatigue → Replace the shock absorber assembly.
Inspect bushes, collar and dust seals.
Wear/damage → Replace.

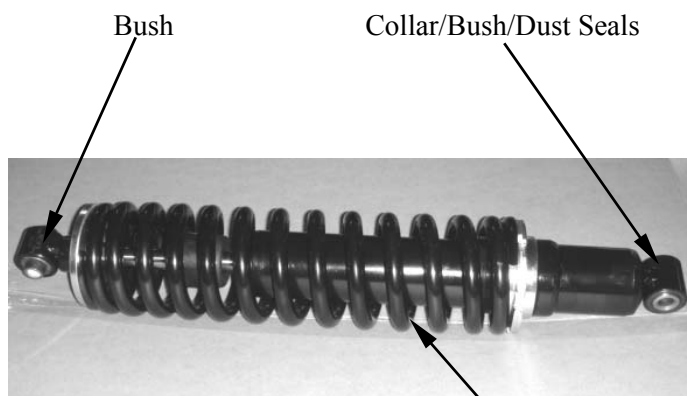

Shock Absorber

INSTALLATION

Apply the grease onto the bushes, then install the shock absorber and tighten the upper mount and lower mount bolts/nuts to the specified torque.

Torque: 4.8 kgf-m (48 N-m, 35 lbf-ft)

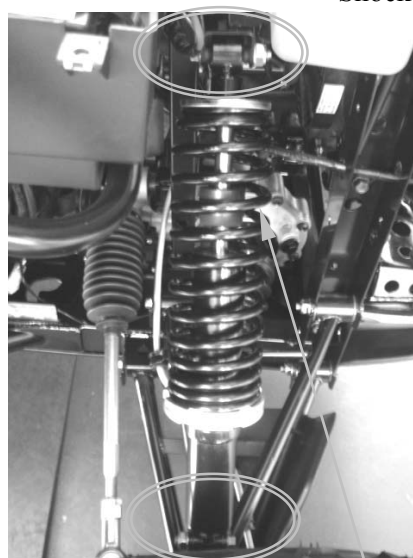

Shock Absorber

14. FRONT WHEEL/FRONT SUSPENSION/ STEERING SYSTEM

KYMCO
MXU550EXi/MXU500i

STEERING KNUCKLE REMOVAL/INSPECTION/ INSTALLATION

REMOVAL

Elevate the front wheels by placing a suitable stand under the frame.

* Support the machine securely so there is no danger of it falling over.

Remove the front wheel hub

Remove the three bolts and brake disc protection plate.

Remove the cotter pin and nut from the tie-rod end.

Remove the 2 bolts

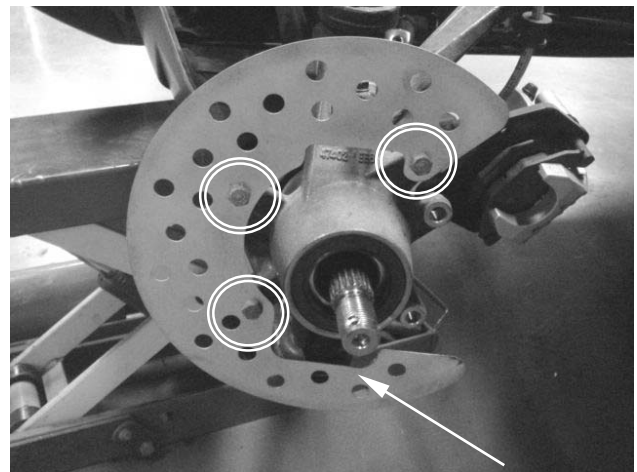

Plate

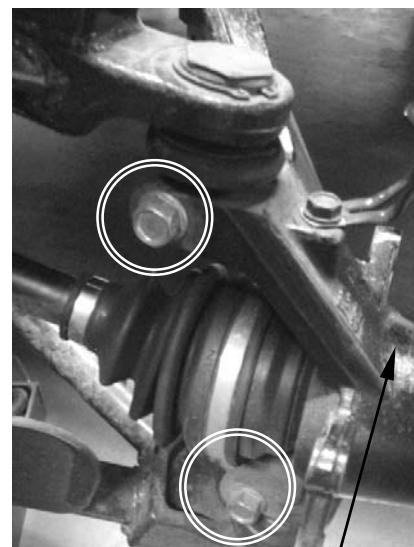

Steering Knuckle

14. FRONT WHEEL/FRONT SUSPENSION STEERING SYSTEM

Release the tie-rod ball joint/upper arm ball joint off the knuckle.

Apply grease to the ball joint remover at the point shown.

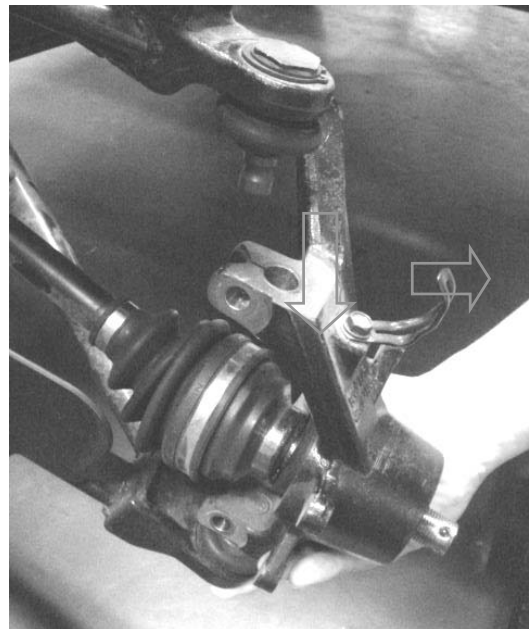
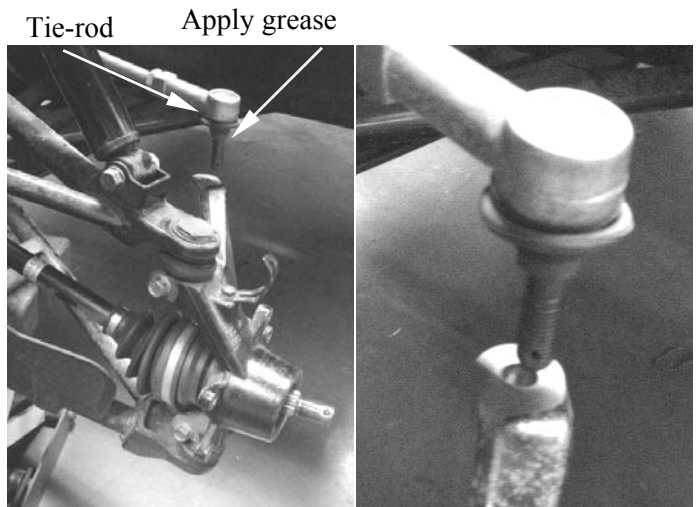

Remove the knuckle from the upper and lower arms



14. FRONT WHEEL/FRONT SUSPENSION/ STEERING SYSTEM

 **KYMCO**
MXU550EXi/MXU500i

INSPECTION

Inspect the knuckle end boot for wear or damage.

If any damages are found, replace the knuckle end with a new one.

Inspect the dust seal lips for wear or damage.

If any damages are found, replace the dust seal with a new one.

Inspect the brake disc protection plate for damage.

If any damages are found, replace the brake disc protection plate with a new one.

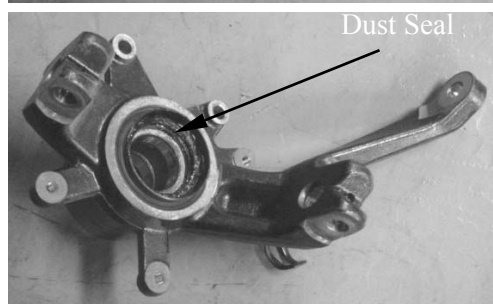
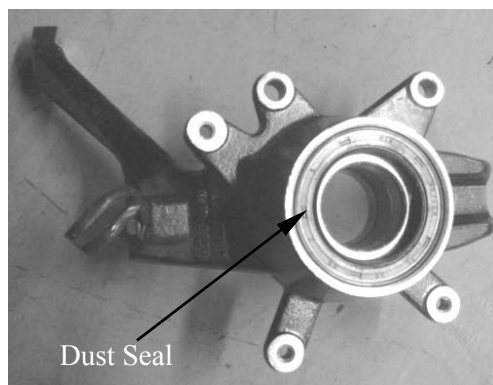

14. FRONT WHEEL/FRONT SUSPENSION STEERING SYSTEM

INSTALLATION

Apply lightweight lithium-soap base grease to the bearings of the steering knuckle and lips of the dust seal before install the steering knuckle.

Install the steering knuckle onto the upper and lower front arms and tighten the nuts to the specified torque.

Torque: 3.5 kgf-m (35 N-m, 25 lbf-ft)

Install the cotter pins and band ends of cotter pins.

*

Always use a new cotter pin.

Install the tie-rod onto the steering knuckle and tighten the nut to the specified torque.

Torque: 4.8kgf-m (48 N-m, 34 lbf-ft)

Install the lock 2 bolts

*

Always use a new cotter pin.

*

- Do not apply oil to the seat of the nuts.
- Do not loosen the nuts after torque tightening. If the nuts groove is not aligned with the cotter pins hole, align groove with the hole by tightening up on the nuts.

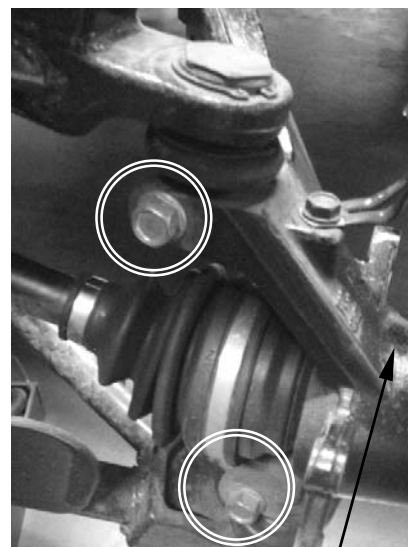

Steering Knuckle

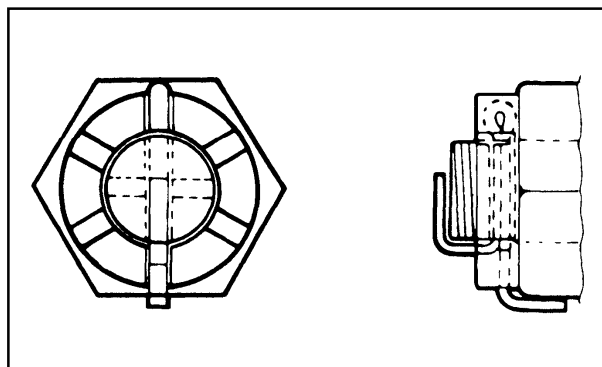

14. FRONT WHEEL/FRONT SUSPENSION/ STEERING SYSTEM

 **KYMCO**
MXU550EXi/MXU500i

Install the brake disc protection plate and then tighten the three bolts securely.

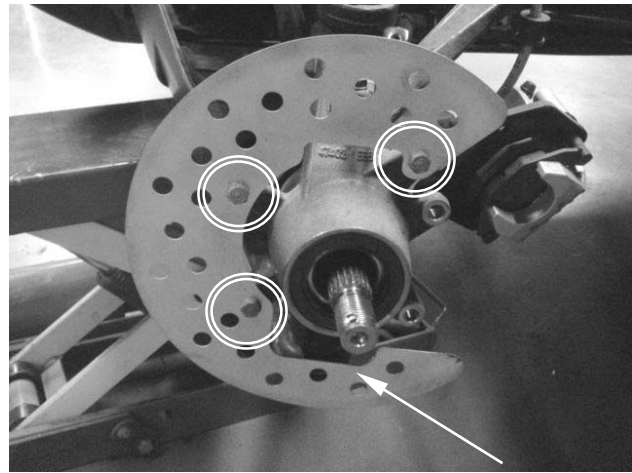

Plate

14. FRONT WHEEL/FRONT SUSPENSION STEERING SYSTEM

STEERING KNUCKLE DISASSEMBLY/ASSEMBLY

DISASSEMBLY

Remove the dust seals.

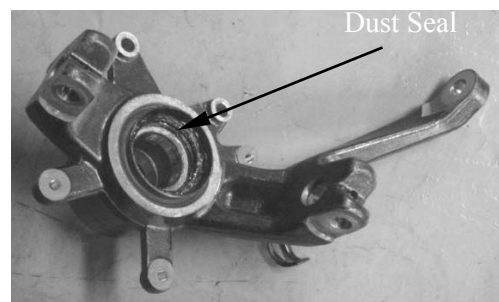
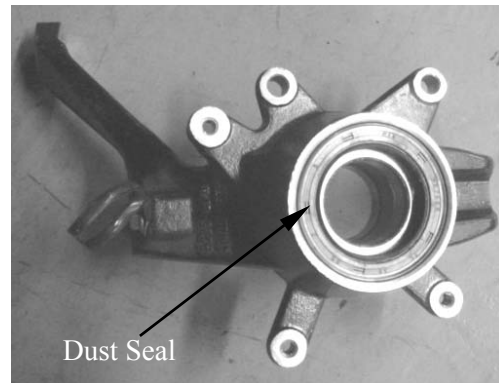

Inspect the inner race play of the bearing by hand while it is in the steering knuckle. Rotate the inner race by hand to inspect for abnormal noise and smooth rotation. If there is anything unusual, replace the bearing with a new one.

* Make sure to check bearing in the same manner.

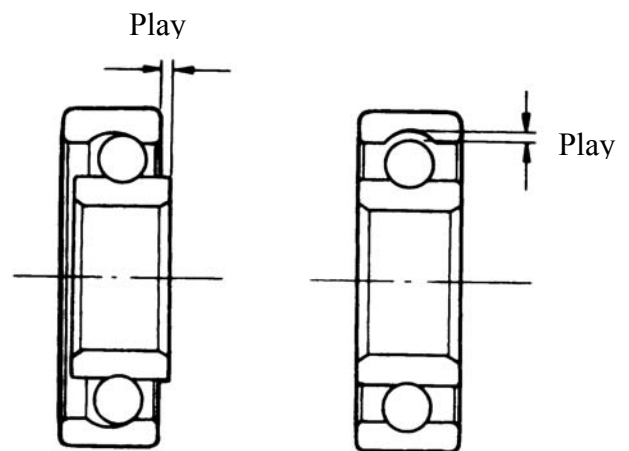

Remove the bearings using the appropriate bar, then remove the spacer.



14. FRONT WHEEL/FRONT SUSPENSION/ STEERING SYSTEM

 **KYMCO**
MXU550EXi/MXU500i

ASSEMBLY

Apply lightweight lithium-soap base grease to the new bearings of the steering knuckle and lips of the new dust seal before install them.



Install the new inner bearing by using the special tool.

Special tool:

Oil seal and bearing driver A120E00014

Install the spacer into the steering knuckle.

* Make sure the long side of the spacer faces the outer bearing



Bearing Driver

Install the new outer bearing by using the special tool.

Special tool:

Oil seal and bearing driver A120E00014



Bearing Driver

Install the new dust seals by using the special tool.

Special tool:

Oil seal and bearing driver A120E00014



14. FRONT WHEEL/FRONT SUSPENSION STEERING SYSTEM

HANDLEBAR REMOVAL/INSPECTION/ INSTALLATION

REMOVAL

Remove the frame cover (refer to the “**FRAME COVERS**” section in the chapter 2).

Remove the two bolts and then remove left master cylinder from the handlebar.
Remove the band and then remove the brake light switch wire from the handlebar.

Master Cylinder

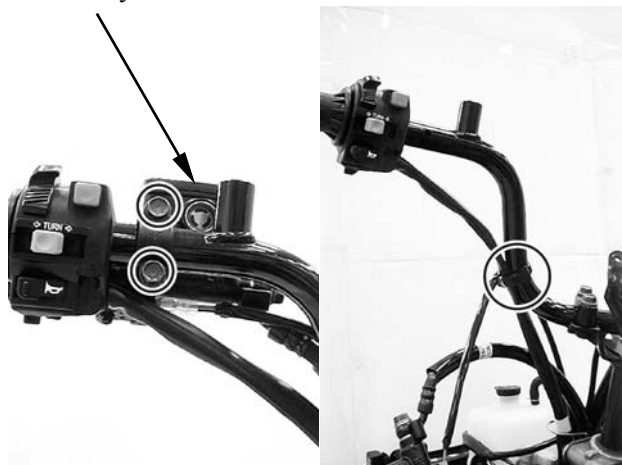

Remove the two screws and then remove the left handlebar switch from the handlebar.

Remove the two screws and then remove the throttle lever assembly.

Throttle Lever Assembly

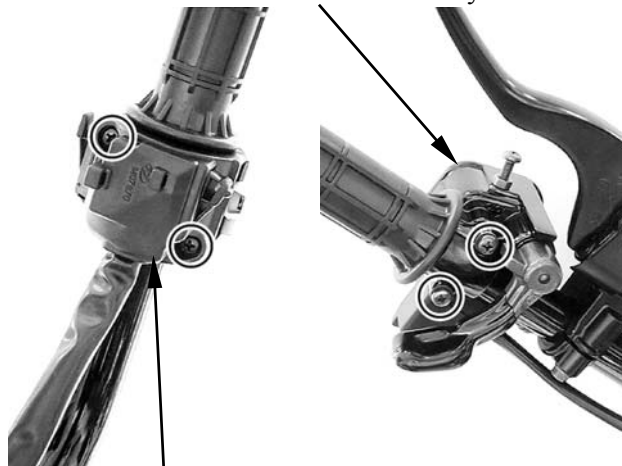

Left Handlebar Switch

Remove the nut then remove the choke knob from the handlebar.

Remove the band and then remove the brake light wire and 2WD/4WD select switch wire from the handlebar.

Remove the two bolts and then remove the master right cylinder from the handlebar.

Choke Knob



Master Cylinder



14. FRONT WHEEL/FRONT SUSPENSION/ STEERING SYSTEM

 **KYMCO**
MXU550EXi/MXU500i

Remove the four bolts, then remove the handlebar holders

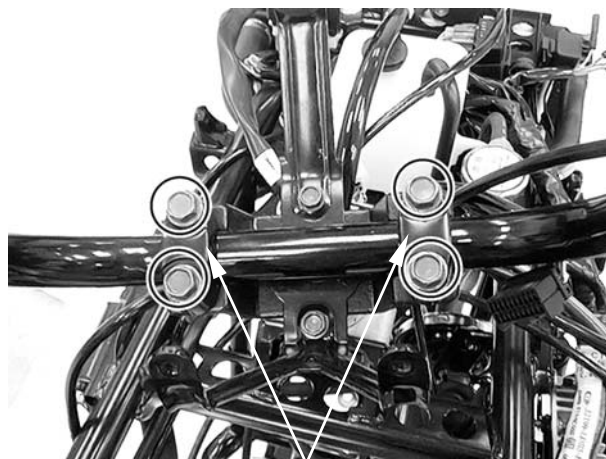

Handlebar Holders

INSPECTION

Inspect the handlebar.
Cracks/bends/damage → Replace.



INSTALLATION

Install handlebar and handlebar holder, then tighten the four bolts.

Torque: 2.5 kgf-m (25 N-m, 18 lbf-ft)

* Align the mark on the handlebar with the lower handlebar holder surface.

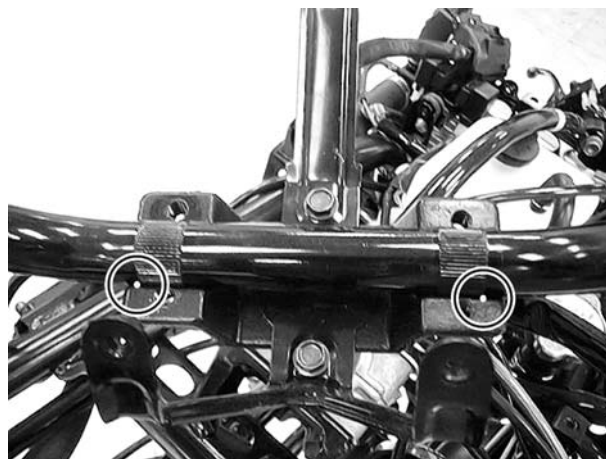

14. FRONT WHEEL/FRONT SUSPENSION STEERING SYSTEM

 **KYMCO**
MXU550EXi/MXU500i

- * • Be sure the handlebar holder mark face to front.
• First tighten the bolts on the front side of the handlebar holder, and then tighten the bolts on the rear side.

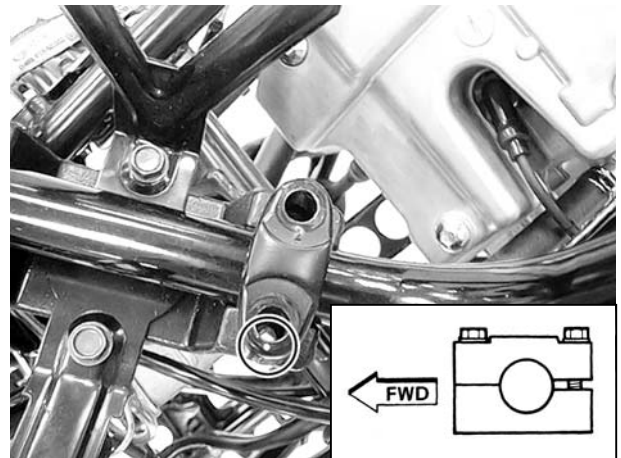

Install the handlebar switch by aligning the pin on the handlebar switch with the hole in the handlebar and then tighten the two screws securely.



Place the right and left brake master cylinder on the handlebar and install the master cylinder holder with the "UP" mark facing up, aligning the punch mark on the handlebar with the holder joint seam. First tighten the upper bolt and then tighten the lower blot.

Torque: 1.2 kgf-m (12 N-m, 8.6 lbf-ft)



14. FRONT WHEEL/FRONT SUSPENSION/ STEERING SYSTEM

 **KYMCO**
MXU550EXi/MXU500i

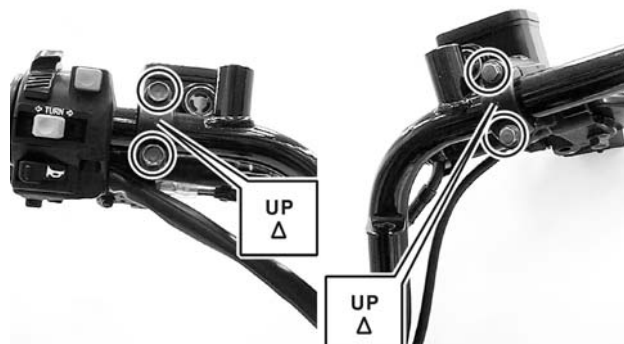

Install the throttle assembly by aligning the upper holder lip with the mark in the handlebar and then install the lower holder and tighten the two screws securely.



14. FRONT WHEEL/FRONT SUSPENSION STEERING SYSTEM

 **KYMCO**
MXU550EXi/MXU500i

STEERING COLUMN REMOVAL/INSPECTION/ INSTALLATION

REMOVAL

Remove frame covers (refer to the “**FRAME COVERS**” section in the chapter 2).

Remove the tie-rods (refer to the “**TIE-ROD REMOVAL/INSPECTION/INSTALLATION**” section in this chapter).

Remove the handlebar (refer to the “**HANDLEBAR REMOVAL/INSPECTION/INSTALLATION**” section in this chapter).

Remove the two bolts and remove the cable holder.

Remove the steering brackets and dust seal.

Cable Holder



Steering Bracket

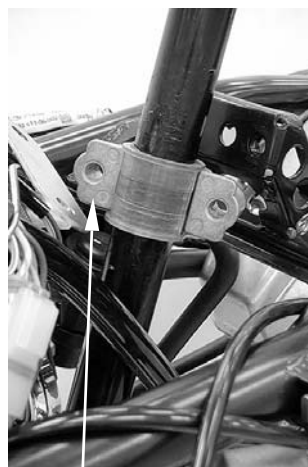

Steering Bracket

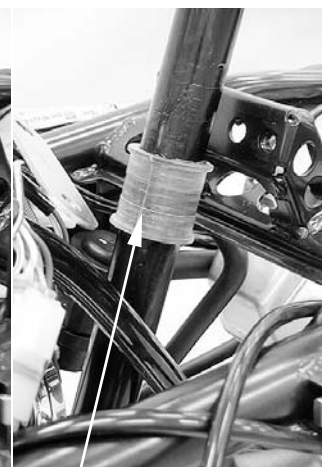

Dust Seal

14. FRONT WHEEL/FRONT SUSPENSION/ STEERING SYSTEM

 **KYMCO**
MXU550EXi/MXU500i

Remove the cotter pin and nut from the steering column under the frame body, then remove steering column.



Remove the collar and dust seal.

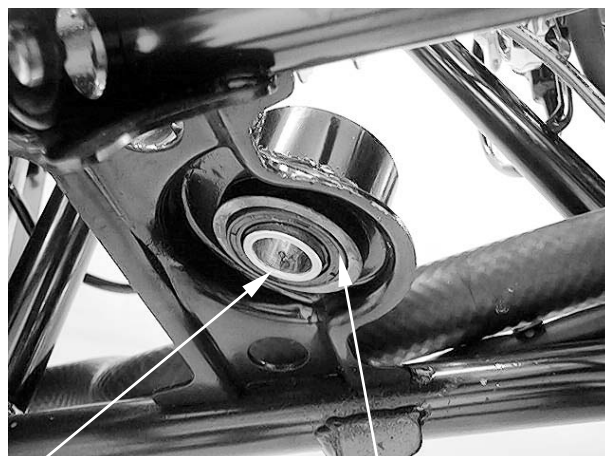

Collar

Dust Seal

Remove the dust seal.
Remove the snap ring.

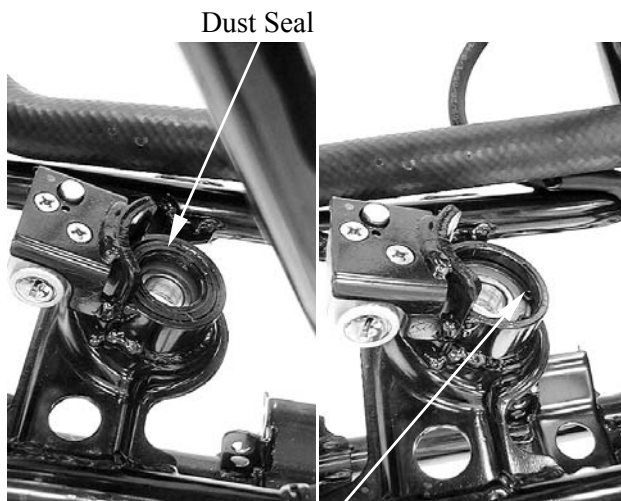

Dust Seal

Snap Ring

14. FRONT WHEEL/FRONT SUSPENSION STEERING SYSTEM

 **KYMCO**
MXU550EXi/MXU500i

Replace the bearing by using the special tool.

Special tool:

Oil seal and bearing driver A120E00014

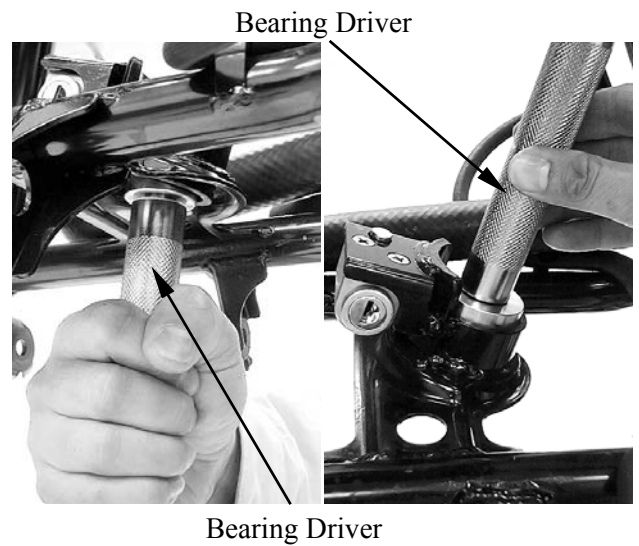

INSPECTION

Inspect the steering column.
Bends/damage → Replace.

- * Do not attempt to straighten a bent steering column, this may dangerously weaken the steering column.

Inspect the steering brackets and oil seal.
Wear damage → Replace.



INSTALLATION

- * Apply the grease onto the collar, dust seals, and bearing.

Install the steering column and collar, then tighten the nut under the frame body.

Torque: 7 kgf-m (70 N-m, 50 lbf-ft)

Install the cotter pin and band ends of cotter pin.

- * Always use a new cotter pin.



14. FRONT WHEEL/FRONT SUSPENSION/ STEERING SYSTEM

 **KYMCO**
MXU550EXi/MXU500i

Install the dust seal, steering brackets and cable holder.

Install and tighten the two bolts to the specified torque.

Torque: 2.2 kgf-m (22 N-m, 16 lbf-ft)

Steering Bracket



Cable Holder



REAR WHEEL/AXLE/SHOCK ABSORBER/SWING ARM

SERVICE INFORMATION-----	15- 2
TROUBLESHOOTING-----	15- 2
REAR WHEEL REMOVAL/INSPECTION/INSTALLATION -----	15- 3
REAR WHEEL HUB REMOVAL/INSPECTION/ INSTALLATION -----	15- 4
REAR SHOCK ABSORBER REMOVAL/INSPECTION/ INSTALLATION -----	15- 6
STEERING KNUCKLE REMOVAL/INSPECTION/ INSTALLATION -----	15- 7
STEERING KNUCKLE DISASSEMBLY/ASSEMBLY -----	15-10

15. REAR WHEEL/AXLE/SHOCK ABSORBER/SWING ARM

KYMCO
MXU550EXi/MXU500i

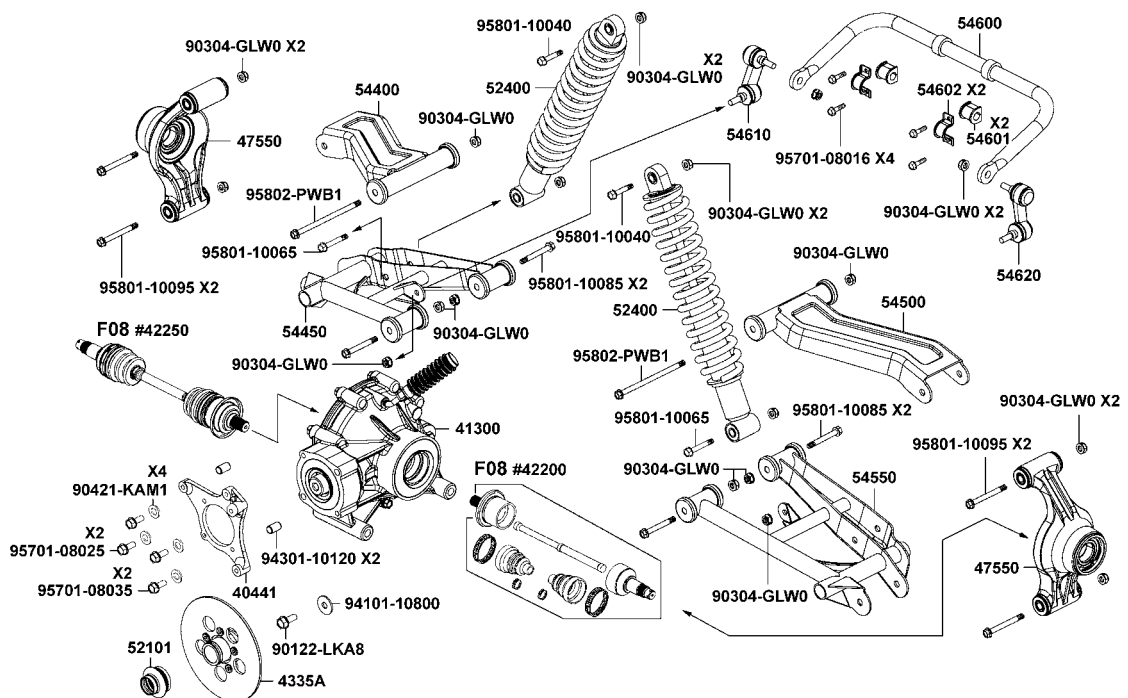
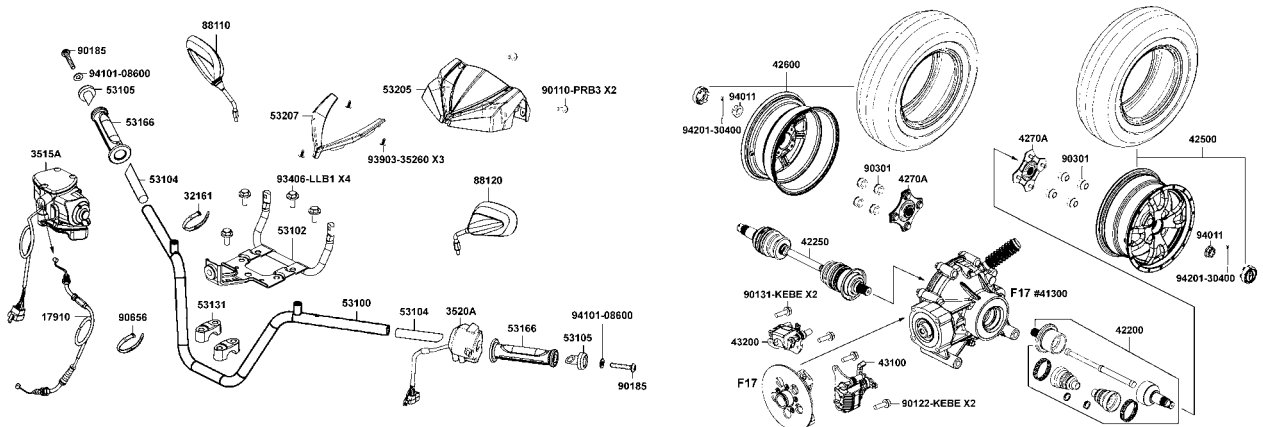

15. REAR WHEEL/AXLE/SHOCK ABSORBER/SWING ARM

SERVICE INFORMATION

GENERAL INSTRUCTIONS

- Jack the machine front wheel off the ground and be careful to prevent the machine from falling down.
- During servicing, keep oil or grease off the brake disk
- Inspect the brake system before riding.

SPECIFICATIONS

Unit: mm (in)

Item		Standard	Service Limit
Rear wheel	Radial	—	2 (0.08)
	Axial	—	2 (0.08)

TORQUE VALUES

Rear wheel nut	6.1 kgf-m (61 N-m, 44 lbf-ft)
Rear shock absorber upper mount bolt	4.8 kgf-m (48 N-m, 35 lbf-ft)
Rear shock absorber lower mount bolt	4.8 kgf-m (48 N-m, 35 lbf-ft)
Rear wheel hub and halfshaft (CVJ)	28 kgf-m (280 N-m, 201 lbf-ft)

SPECIAL TOOLS

Oil seal & bearing driver	A120E00014
---------------------------	------------

TROUBLESHOOTING

Rear wheel wobbling

- Bent rim
- Faulty tire
- Axle not tightened properly

Soft rear shock absorber

- Weak shock absorber spring
- Faulty damper

15. REAR WHEEL/AXLE/SHOCK ABSORBER/SWING ARM

REAR WHEEL REMOVAL/INSPECTION/ INSTALLATION

REMOVAL

Place the machine on a level place.
Remove four nuts from rear wheel.

Elevate the rear wheels by placing a suitable stand under the frame.

* Support the machine securely so there is no danger of it falling over.

Remove the rear wheel and wheel hub nut cap together.



INSPECTION

Measure the wheel run out.
Replace wheel or check bearing play if out of specification

Rim run out limits:

Vertical: 2 mm (0.08 in)

Lateral: 2 mm (0.08 in)

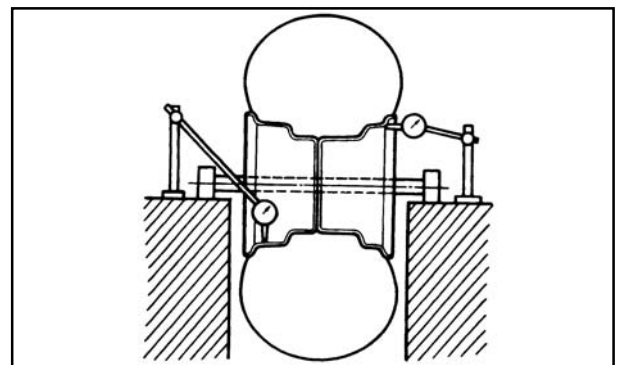

INSTALLATION

When reinstalling a wheel, tighten the wheel nuts in a crisscross (rather than a circular) pattern.

Torque: 6.1 kgf-m (61N-m, 44 lbf-ft)

* Be sure the tapered side of the wheel nuts face the wheel rim.

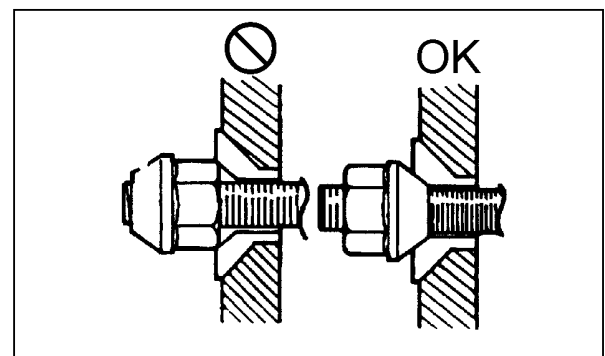

15. REAR WHEEL/AXLE/SHOCK ABSORBER/SWING ARM

KYMCO
MXU550EXi/MXU500i

REAR WHEEL HUB REMOVAL/INSPECTION/ INSTALLATION

REMOVAL

Place the machine on a level place.
Remove the rear wheel (refer to the “**REAR WHEEL REMOVAL/INSPECTION/INSTALLATION**” section in this chapter)
Elevate the rear wheels by placing a suitable stand under the frame.

* Support the machine securely so there is no danger of it falling over.

Remove the cotter pin.
Apply the rear brake and then remove nut and rear wheel hub.

INSPECTION

Check the wheel hub for cracks or damage.
Check the wheel hub splines for wear or damage.

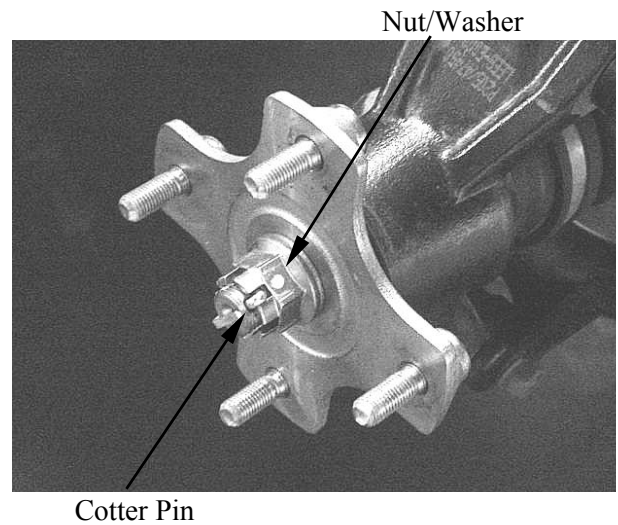

15. REAR WHEEL/AXLE/SHOCK ABSORBER/SWING ARM

INSTALLATION

Install the wheel hub and nut.

- * Apply lightweight lithium-soap base grease onto the wheel hub splines, rear axle splines and dust seal lips of the axle housing.

Apply grease

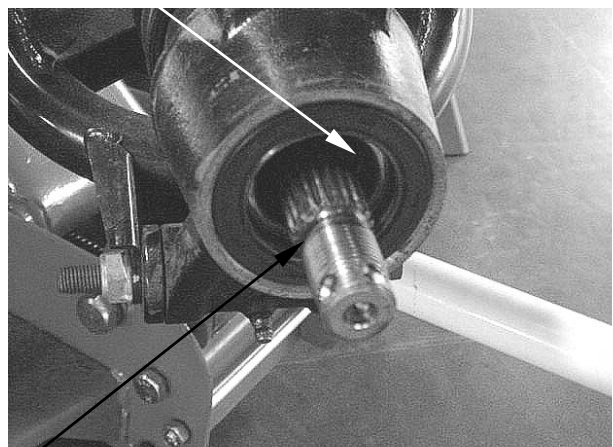

Apply grease

Apply the front brake and then tighten the nut to the specified torque.

Torque: 28 kgf-m (280 N-m, 201 lbf-ft)

Install the cotter pin and band ends of cotter pin.

Nut/Washer

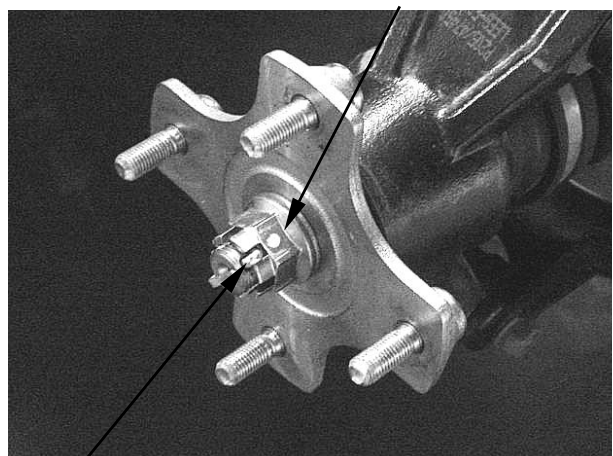

Cotter Pin

- *
 - Do not apply oil to the seat of the nut.
 - Do not loosen the wheel hub nut after torque tightening. If the wheel hub nut groove is not aligned with the cotter pin hole, align groove with the hole by tightening up on the wheel hub nut.

- * Always use a new cotter pin.

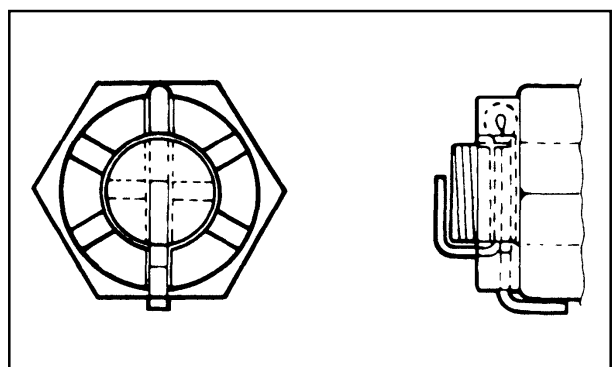

15. REAR WHEEL/AXLE/SHOCK ABSORBER/SWING ARM

KYMCO
MXU550EXi/MXU500i

REAR SHOCK ABSORBER REMOVAL/INSPECTION/ INSTALLATION

REMOVAL

Remove the rear shock absorber upper mount nut and washer.

Remove the lower mount bolt/nut, then remove the rear shock absorber.



INSPECTION

Inspect the shock absorber rod.

Bends/damage → Replace the shock absorber assembly.

Inspect the shock absorber.

Oil leaks → Replace the shock absorber assembly.

Inspect the spring of the shock absorber by move the spring up and down.

Fatigue → Replace the shock absorber assembly.

Inspect bushes, collar and dust seals.

Wear/damage → Replace.

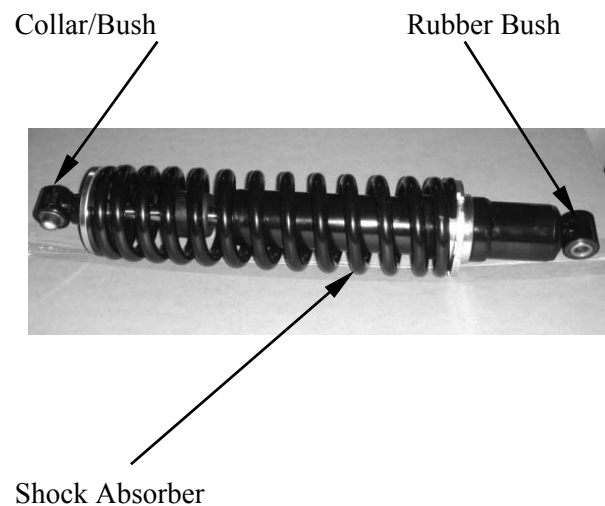

INSTALLATION

Apply the grease onto the bushes then install the shock absorber and tighten the lower mount bolt/nut to the specified torque.

Torque: 4.8 kgf-m (48 N-m, 35 lbf-ft)

Install and tighten the upper mounting nut to the specified torque.

Torque: 4.8 kgf-m (48 N-m, 35 lbf-ft)

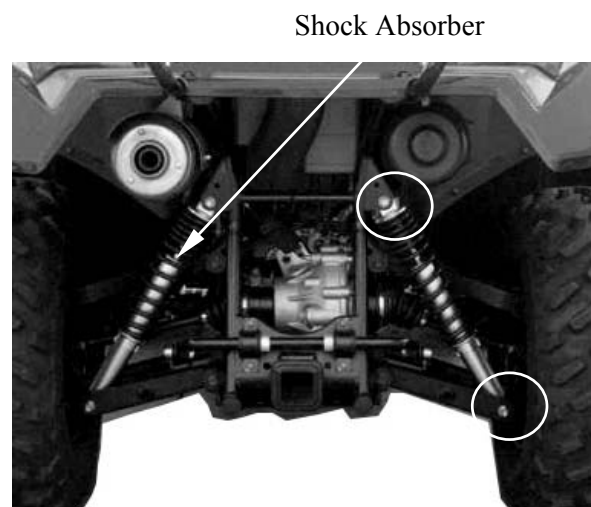

15. REAR WHEEL/AXLE/SHOCK ABSORBER/SWING ARM

STEERING KNUCKLE REMOVAL/INSPECTION/ INSTALLATION

REMOVAL

Elevate the rear wheels by placing a suitable stand under the frame.

* Support the machine securely so there is no danger of it falling over.

Remove the rear wheel hub

Remove the cotter pin and nut from the tie-rod end.

Remove the 2 bolts

Remove the knuckle from the upper and lower arms

Apply grease

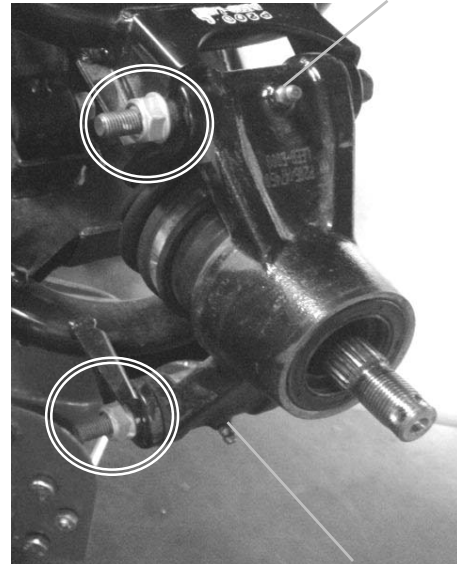

Apply grease

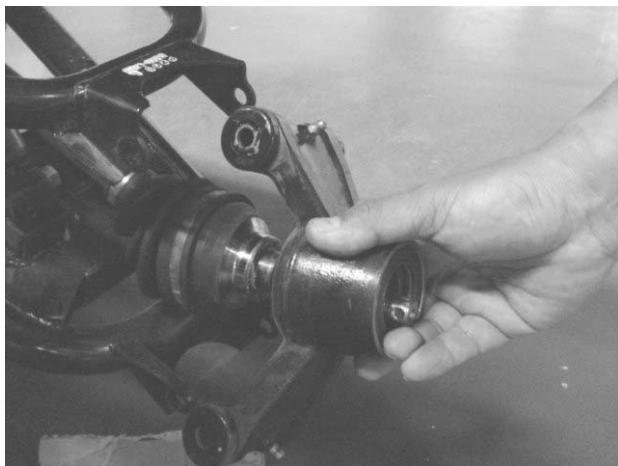
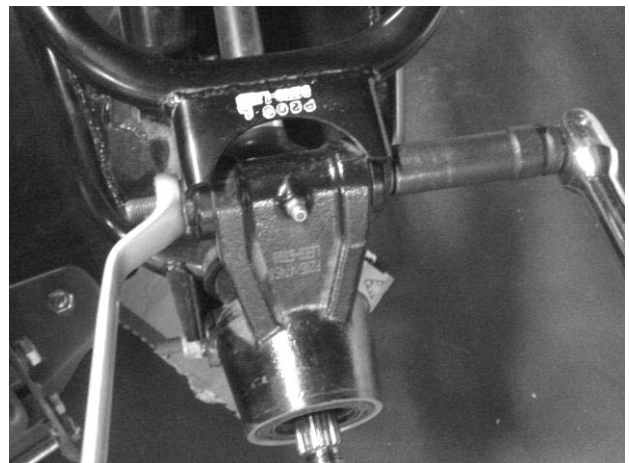

15. REAR WHEEL/AXLE/SHOCK ABSORBER/SWING ARM

KYMCO
MXU550EXi/MXU500i

INSPECTION

Inspect the knuckle end boot for wear or damage.

If any damages are found, replace the knuckle end with a new one.

Knuckle End Boot



Dust Seal

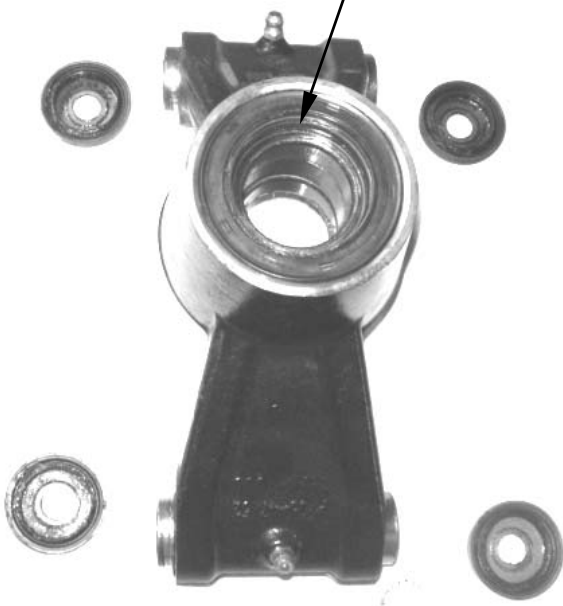

Dust Seal

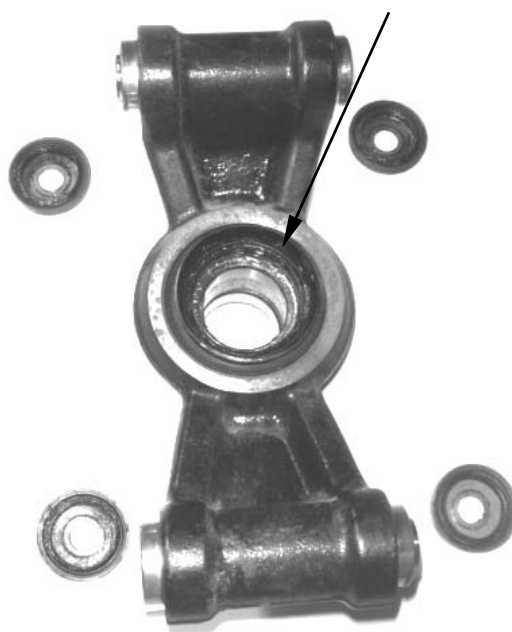

15. REAR WHEEL/AXLE/SHOCK ABSORBER/SWING ARM

 **KYMCO**
MXU550EXi/MXU500i

INSTALLATION

Install the tie-rod onto the steering knuckle and tighten the nut to the specified torque.

Torque: 4.8 kgf-m (48 N-m, 35 lbf-ft)

Install the lock 2 bolts

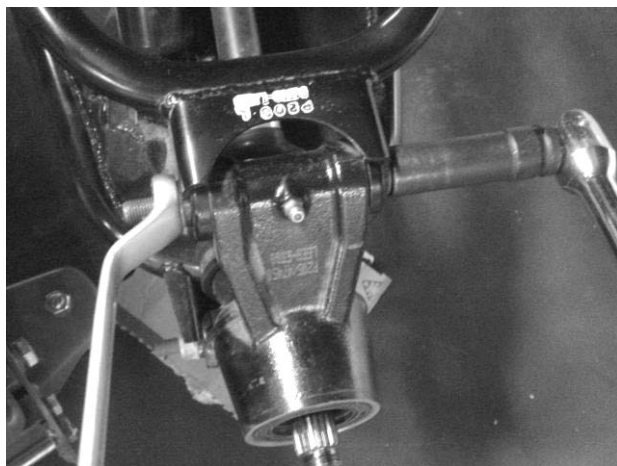

*

- Do not apply oil to the seat of the nuts.
- Do not loosen the nuts after torque tightening. If the nuts groove is not aligned with the cotter pins hole, align groove with the hole by tightening up on the nuts.

Apply grease

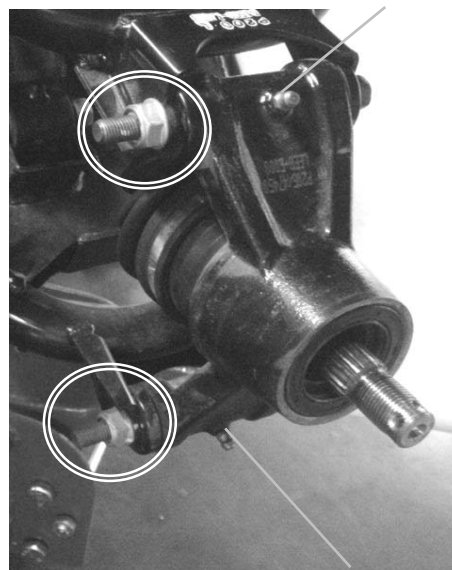

Apply grease

15. REAR WHEEL/AXLE/SHOCK ABSORBER/SWING ARM

KYMCO
MXU550EXi/MXU500i

STEERING KNUCKLE DISASSEMBLY/ASSEMBLY

DISASSEMBLY

Remove the dust seals.

Inspect the inner race play of the bearing by hand while it is in the steering knuckle.

Rotate the inner race by hand to inspect for abnormal noise and smooth rotation.

If there is anything unusual, replace the bearing with a new one.

* Make sure to check bearing in the same manner.

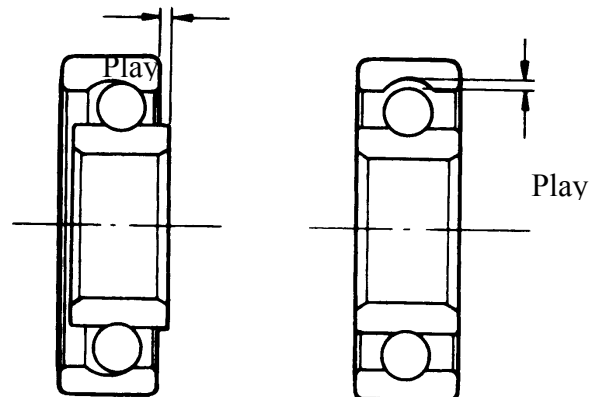
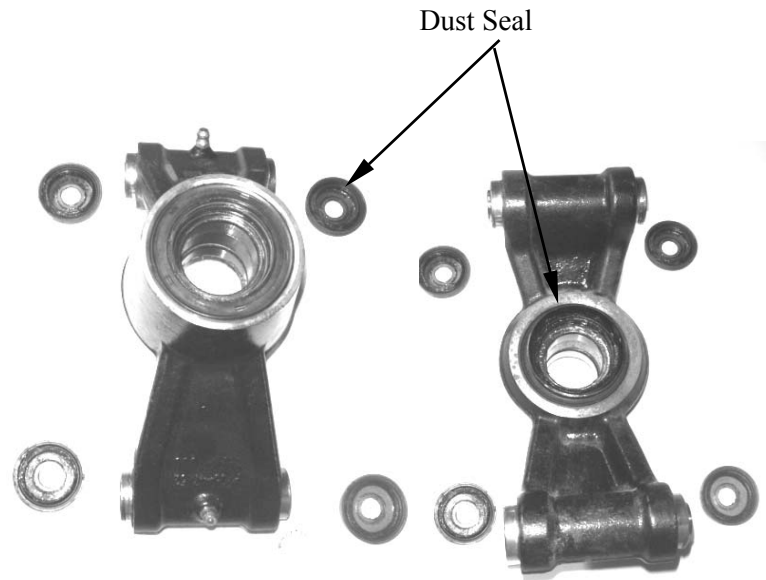

Remove the bearings using the appropriate bar, then remove the spacer.



15. REAR WHEEL/AXLE/SHOCK ABSORBER/SWING ARM

ASSEMBLY

Apply lightweight lithium-soap base grease to the new bearings of the steering knuckle and lips of the new dust seal before install them.



Install the new inner bearing by using the special tool.

Special tool:
Oil seal and bearing driver A120E00014

Install the spacer into the steering knuckle.

* Make sure the long side of the spacer faces the outer bearing.

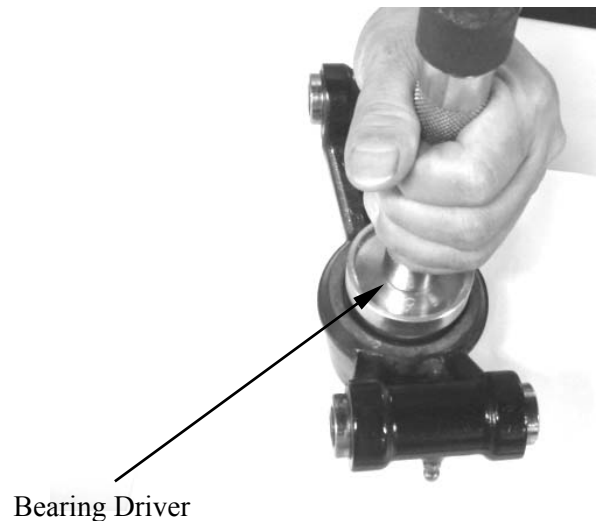

Bearing Driver

Duct Seal

Install the new outer bearing by using the special tool.

Special tool:
Oil seal and bearing driver A120E00014

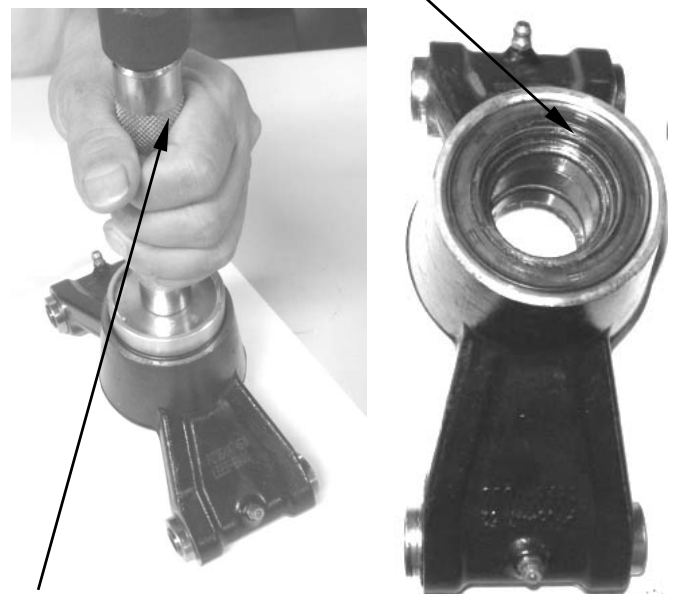

Bearing Driver

Install the new dust seals by using the special tool.

Special tool:
Oil seal and bearing driver A120E00014

BRAKE SYSTEM

SERVICE INFORMATION-----	16- 2
TROUBLESHOOTING-----	16- 3
BRAKE PADS REPLACEMENT-----	16- 4
FRONT BRAKE DISCS REMOVAL/INSPECTION/ INSTALLATION-----	16- 9
REAR BRAKE DISC REMOVAL/INSPECTION/ INSTALLATION-----	16-10
FRONT BRAKE FLUID CHANGE/AIR BLEED-----	16-11
REAR BRAKE FLUID CHANG/AIR BLEED-----	16-14
COMBINATION BRAKE FLUID CHANG/ AIR BLEED-----	16-17
BRAKE MASTER CYLINDERS REMOVAL/ INSPECTION/ INSTALLATION-----	16-23
BRAKE MASTER CYLINDER DISASSEMBLY/INSPECTION/ ASSEMBLY-----	16-28
DELAY VALVE REMOVAL/DISASSEMBLY/INSPECTION/ ASSEMBLY/INSTALLATION-----	16-31
FRONT BRAKE CALIPERS REMOVAL/INSPECTION/ INSTALLATION-----	16-34
REAR BRAKE CALIPERS REMOVAL/INSPECTION/ INSTALLATION-----	16-35
REAR BRAKE/PARKING BRAKE CALIPER REMOVAL/ INSPECTION/INSTALLATION-----	16-36
BRAKE CALIPER DISASSEMBLY/INSPECTION/ASSEMBLY--	16-37
REAR BRAKE/PARKING BRAKE CALIPER DISASSEMBLY/INSPECTION/ASSEMBLY-----	16-40

16. BRAKE SYSTEM

MXU550EXi/MXU500i

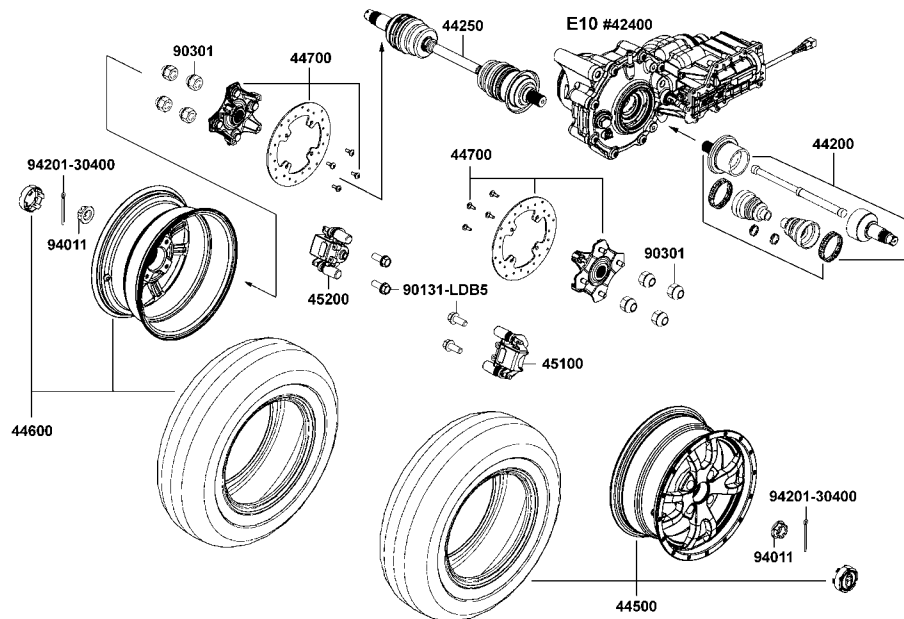
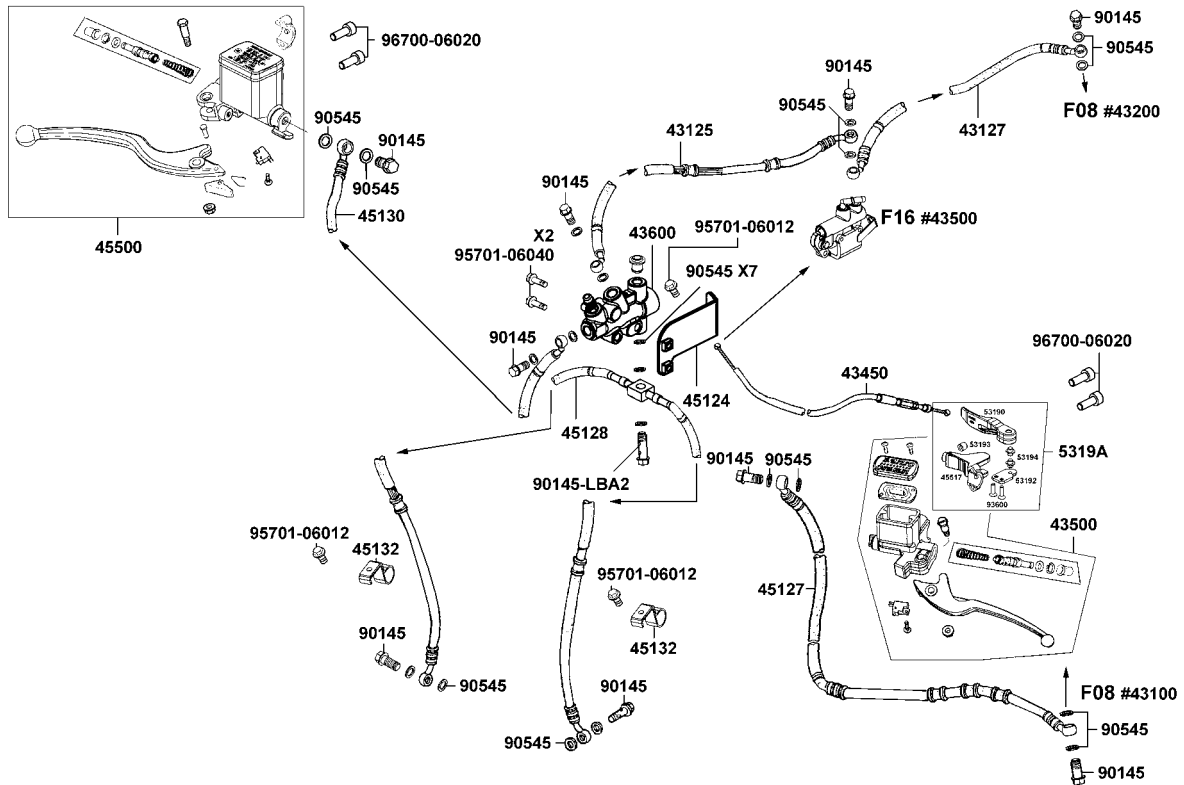

16. BRAKE SYSTEM

SERVICE INFORMATION

GENERAL INSTRUCTIONS

- During servicing, keep oil or grease off the brake pads and brake disk.
- Drain the brake fluid from the hydraulic brake system before disassembly.
- Contaminated brake disk or brake pads reduce stopping power. Clean the contaminated brake disk with high-performance brake degreaser and replace the brake pads.
- Do not use brake fluid for cleaning.
- Bleed air from the brake system if the brake system is removed or the brake is soft.
- Do not allow any foreign matters entering the brake reservoir when filling the brake reservoir with brake fluid.
- Brake fluid will damage painted, coated surfaces and plastic parts. When working with brake fluid, use shop towels to cover and protect painted, rubber and plastic parts. Wipe off any splash of brake fluid with a clean towel. Do not wipe the machine with a towel contaminated by brake fluid.
- Make sure to use recommended brake fluid. Use of other unspecified brake fluids may cause brake failure.
- Inspect the brake operation before riding.

SPECIFICATIONS

Unit: mm (in)

Item	Standard	Service Limit
Brake disk thickness	FR:4.0(0.156) RR:5.0(0.195)	FR:3 (0.12)RR:4(0.156)
Brake disk runout	—	0.3 (0.012)

TORQUE VALUES

Caliper mounting bolt	2.7 kgf-m (27N-m, 19.5 lbf-ft)
Brake pad mounting bolt	1.8 kgf-m (18 N-m, 13 lbf-ft)
Brake disc bolt	3.5 kgf-m (35 N-m, 25.2 lbf-ft)
Bleed valve nut	0.6 kgf-m (6 N-m, 4.32 lbf-ft)
Brake hose bolt	3.5 kgf-m (35 N-m, 35 lbf-ft)
Master cylinder mounting bolt	1.2 kgf-m (12 N-m, 8.6 lbf-ft)
Delay valve mounting bolt	1.2 kgf-m (12 N-m, 8.6 lbf-ft)
Delay valve plug	5 kgf-m (50 N-m, 36 lbf-ft)

TROUBLESHOOTING

Loose brake lever

- Air in hydraulic brake system
- Brake fluid level too low
- Hydraulic brake system leakage

Poor brake performance

- Air in brake system
- Deteriorated brake fluid
- Contaminated brake pads and brake disk
- Worn brake pads
- Worn brake master cylinder piston oil seal
- Clogged brake fluid line
- Deformed brake disk
- Unevenly worn brake caliper

Tight brake lever

- Seized piston
- Clogged hydraulic brake system
- Smooth or worn brake pad

Brake noise

- Contaminated brake pad surface
- Excessive brake disk run out
- Incorrectly installed caliper
- Brake disk or wheel not aligned

Hard braking

- Seized hydraulic brake system
- Seized piston

BRAKE PADS REPLACEMENT

FRONT BRAKE PADS

Remove the front wheel. (refer to the “**FRONT WHEEL REMOVAL/INSPECTION/INSTALLATION**” section in the chapter 14).

Remove the two brake pad pins from the brake caliper.

Remove the two mounting bolts from brake caliper and then remove brake caliper.

- *

<ul style="list-style-type: none">• Do not operate the brake lever during or after brake pad removal.• Replace the brake pads as a set, otherwise braking performance will be adversely affected.
--



Compress the brake caliper holder and remove brake pads.



16. BRAKE SYSTEM

A wear indicator is provided on each brake. The indicators are allowed checking of brake pads wear. Check the position of the indicator.

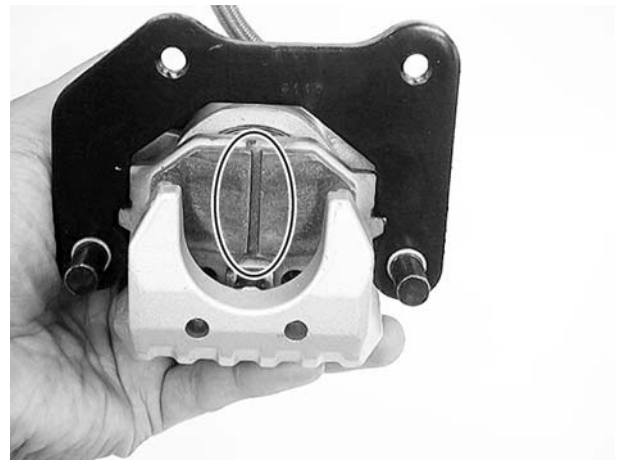

Install the new brake pads.

Install the brake pad mounting pins.
Install the brake caliper mounting bolts to the specified torque.

Torque: 2.7 kgf-m (27 Nm, 19.5 lbf-ft)

Tighten the brake pad mounting pins.

Torque: 1.8 kgf-m (18 Nm, 13 lbf-ft)

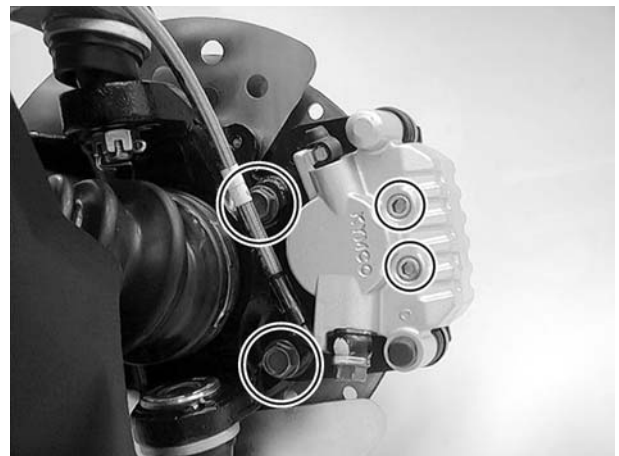

REAR BRAKE PADS

The replacement of rear brake and front brake pads are the same.



REAR BRAKE PADS

Rear brake

The replacement of rear brake and front brake pads are the same.

Rear brake (combined)

Remove the two brake pad pins from the brake caliper.

Remove the two mounting bolts from brake caliper and then remove brake caliper.

*

- Do not operate the brake lever during or after brake pad removal.
- Replace the brake pads as a set, otherwise braking performance will be adversely affected.



16. BRAKE SYSTEM

Compress the brake caliper holder and remove brake pads.



A wear indicator is provided on each brake. The indicators are allowed checking of brake pads wear. Check the position of the indicator.

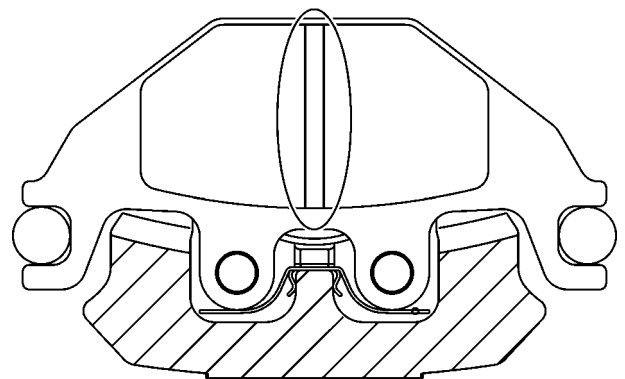

Install the new brake pads.
Install the brake pad mounting pins.



16. BRAKE SYSTEM

Install the brake caliper mounting bolts to the specified torque.

Torque: 2.7 kgf-m (27 Nm, 19.5lbf-ft)

Tighten the brake pad mounting pins.

Torque: 1.8 kgf-m (18 Nm, 13 lbf-ft)

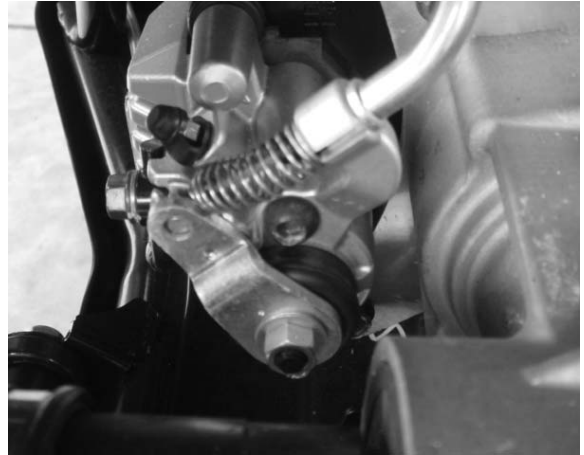

FRONT BRAKE DISCS REMOVAL/INSPECTION/ INSTALLATION

REMOVAL

Remove the front wheel hub (refer to the “**FRONT WHEEL HUB REMOVAL/INSPECTION/INSTALLATION**” section in the chapter 14).

Remove the four bolts and then remove the brake disc.

INSPECTION

Measure the brake disc thickness.

Service Limit: 3 mm (0.12 in)

Measure the brake disk run out.

Service Limit: 0.3 mm (0.012 in)

INSTALLATION

Install the brake disc onto the wheel hub.
Install and tighten the new four bolts to the specified torque.

Torque: 3.5 kgf-m (35 Nm, 25.2 lbf-ft)



Brake Disc

REAR BRAKE DISC REMOVAL/INSPECTION/ INSTALLATION

REMOVAL

- Remove the rear wheel hub
- Remove the rear wheels.
- Remove the rear drive bolts.
- Disconnect the rear drive and shaft
- Rear propeller connect position(holder disk rear brake).
- Remove the rear drive
- Remove the **5** bolts and then remove the brake disc.(Use the impact driver remove it)

INSPECTION

Measure the brake disc thickness.

Service Limit: 4 mm (0.16 in)

Measure the brake disk run out.

Service Limit: 0.3 mm (0.012 in)

INSTALLATION

- Install the brake disc onto the wheel hub.
- Install and tighten the new four bolts to the specified torque.

Torque: 3.5 kgf-m (35 Nm, 25.2 lbf-ft)

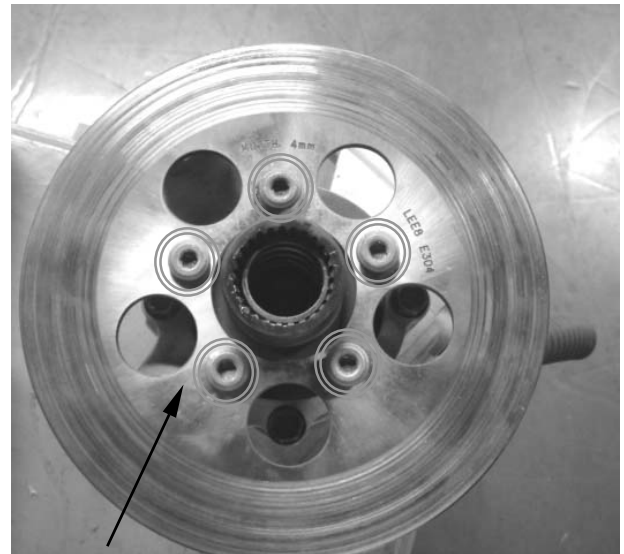

Brake Disc



Impact Driver



16. BRAKE SYSTEM

FRONT BRAKE FLUID CHANGE/AIR BLEED (OFF ROAD)

BRAKE FLUID CHANGE

Place the machine on the level ground and set the handlebar upright.

Remove the two screws from the brake fluid reservoir cap.

* Use shop towels to cover plastic parts and coated surfaces to avoid damage caused by splash of brake fluid.

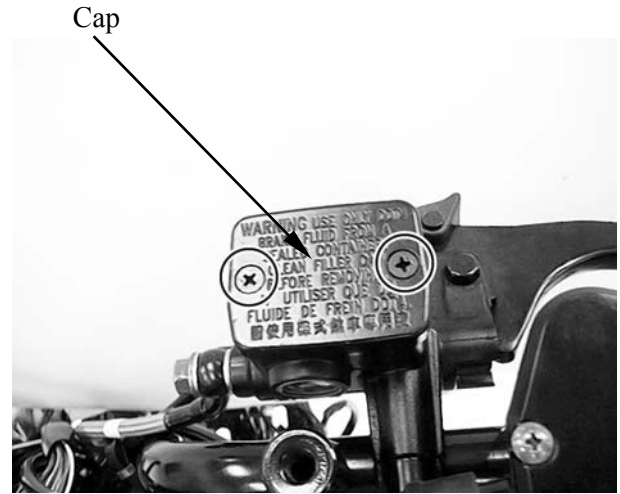

Connect a transparent hose to the brake caliper bleed valve (right and calipers) and then loosen the bleed valve nuts.

Use a syringe to draw the brake fluid out through the hose. Then, tighten the bleed valve nuts.

Torque: 0.6 kgf-m (6 Nm, 4.32 lbf-ft)

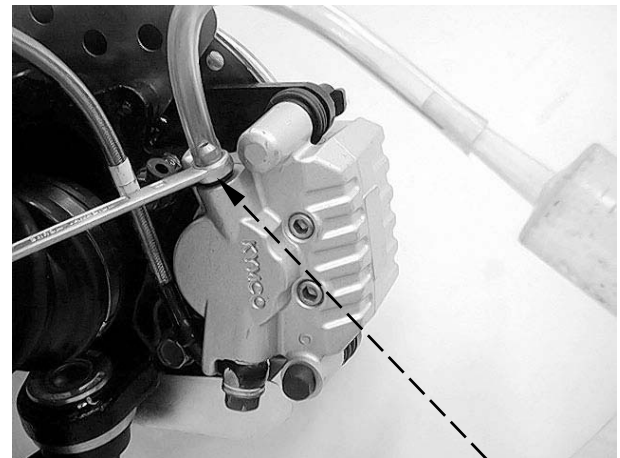

Bleed Valve Nut

Fill the brake reservoir with brake fluid.

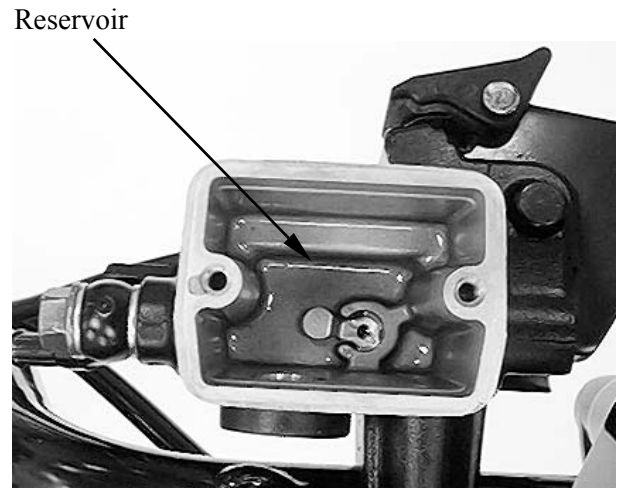

16. BRAKE SYSTEM

Connect a transparent hose to the right caliper bleed valve and then loosen the bleed valve nuts.

Use the syringe to draw brake fluid into it until there is no air bubbles in the transparent hose.

Then, tighten the bleed valve nut.

Torque: 0.6 kgf-m (6 Nm, 4.32 lbf-ft)

Connect a transparent hose to the left caliper bleed valve and then loosen the bleed valve nuts.

Use the syringe to draw brake fluid into it until there is no air bubbles in the transparent hose.

Then, tighten the bleed valve nut.

Torque: 0.6 kgf-m (6 Nm, 4.32 lbf-ft)

*

- When drawing brake fluid with the syringe, the brake fluid level should be kept over 1/2 of the brake reservoir height.
- Use only the recommended brake fluid.

Recommended Brake Fluid: DOT-4

16. BRAKE SYSTEM

BRAKE SYSTEM BLEEDING

1. Connect a transparent hose to the bleed valves (right and left caliper).
2. Fully apply the brake lever after continuously pull it several times. Then, loosen the right caliper bleed valve nut to bleed air from the brake system.
3. Fully apply the brake lever after continuously pull it several times. Then, loosen the left caliper bleed valve nut to bleed air from the brake system.
4. Repeat these steps until the brake system is free of air.

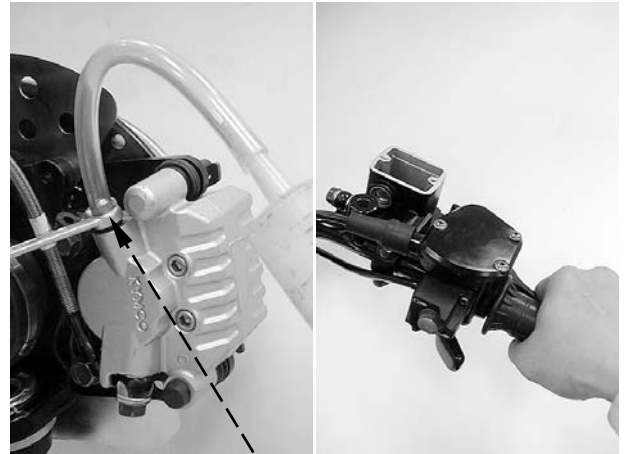

Bleed Valve

*

When bleeding air from the brake system, the brake fluid level should be kept over 1/2 of the brake reservoir height.

REAR BRAKE FLUID CHANGE/AIR BLEED

BRAKE LEVER

Brake fluid change

Place the machine on the level ground and set the handlebar upright.

Remove the brake fluid reservoir cap.

- *

Use shop towels to cover plastic parts and coated surfaces to avoid damage caused by splash of brake fluid.

Connect a transparent hose to the brake caliper bleed valve and then loosen the bleed valve nut.

Use a syringe to draw the brake fluid out through the hose.

Fill the brake reservoir with brake fluid and use the syringe to draw brake fluid into it until there is no air bubbles in the transparent hose.

Then, tighten the bleed valve nut.

Torque: 0.6 kgf-m (6 Nm, 4.32 lbf-ft)

- *

<ul style="list-style-type: none">• When drawing brake fluid with the syringe, the brake fluid level should be kept over 1/2 of the brake reservoir height.• Use only the recommended brake fluid.

Recommended Brake Fluid: DOT-4



Reservoir Cap

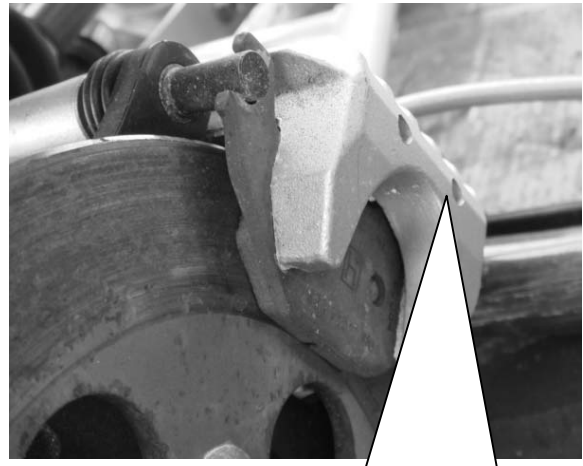

Bleed Valve

16. BRAKE SYSTEM

Brake system bleeding

1. Connect a transparent hose to the bleed valve.
2. Fully apply the brake lever after continuously pull it several times. Then, loosen the caliper bleed valve nut to bleed air from the brake system.
3. Repeat these steps until the brake system is free of air.

* When bleeding air from the brake system, the brake fluid level should be kept over 1/2 of the brake reservoir height.

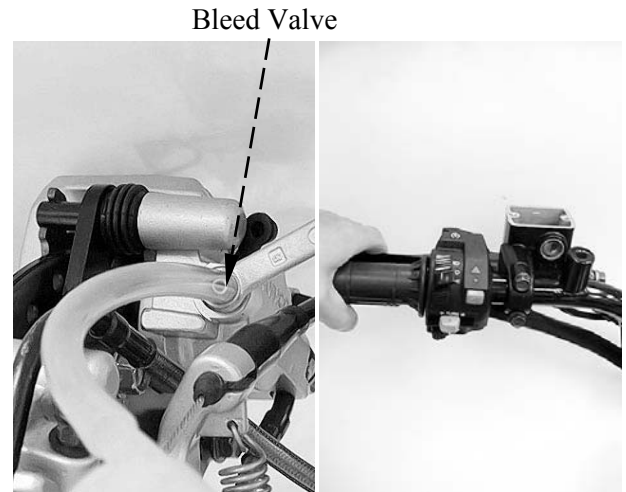

BRAKE PEDAL

Brake fluid change

Place the machine on the level ground and set the handlebar upright.
Remove the brake fluid reservoir cap.

* Use shop towels to cover plastic parts and coated surfaces to avoid damage caused by splash of brake fluid.

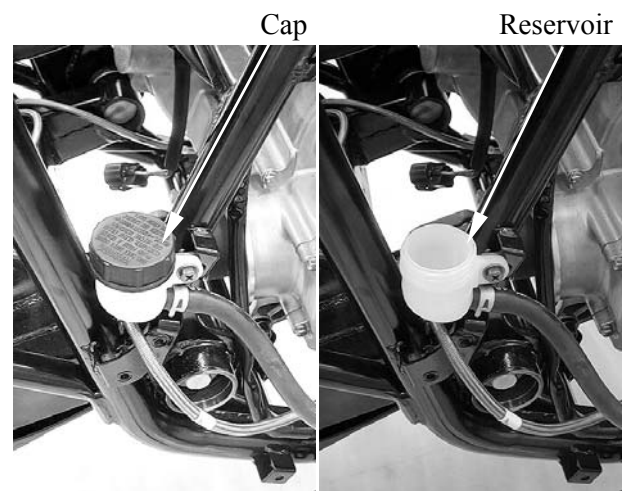

16. BRAKE SYSTEM

Connect a transparent hose to the brake caliper bleed valve and then loosen the bleed valve nut.

Use a syringe to draw the brake fluid out through the hose.

Fill the brake reservoir with brake fluid and use the syringe to draw brake fluid into it until there is no air bubbles in the transparent hose.

Then, tighten the bleed valve nut.

Torque: 0.6 kgf-m (6 Nm, 4.32 lbf-ft)

- * _____
- When drawing brake fluid with the syringe, the brake fluid level should be kept over 1/2 of the brake reservoir height.
 - Use only the recommended brake fluid.

Recommended Brake Fluid: DOT-4

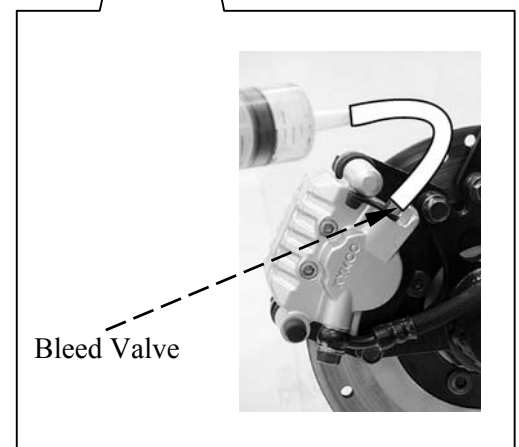

Brake system bleeding

1. Connect a transparent hose to the bleed valve.
2. Fully apply the brake pedal after continuously depress it several times. Then, loosen the caliper bleed valve nut to bleed air from the brake system.
3. Repeat these steps until the brake system is free of air.

- * _____
- When bleeding air from the brake system, the brake fluid level should be kept over 1/2 of the brake reservoir height.

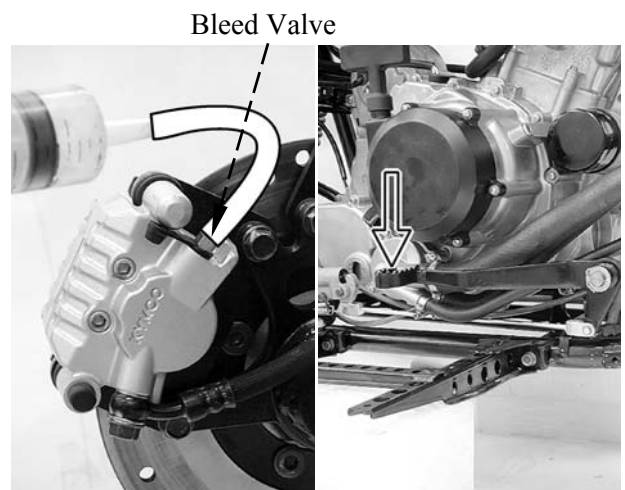

16. BRAKE SYSTEM

COMBINATION BRAKE FLUID CHANGE/AIR BLEED

BRAKE FLUID CHANGE

Place the machine on the level ground and set the handlebar upright.

1. Remove the two screws from the brake fluid reservoir cap.
2. Remove the brake fluid reservoir cap (front brake lever).

* Use shop towels to cover plastic parts and coated surfaces to avoid damage caused by splash of brake fluid.

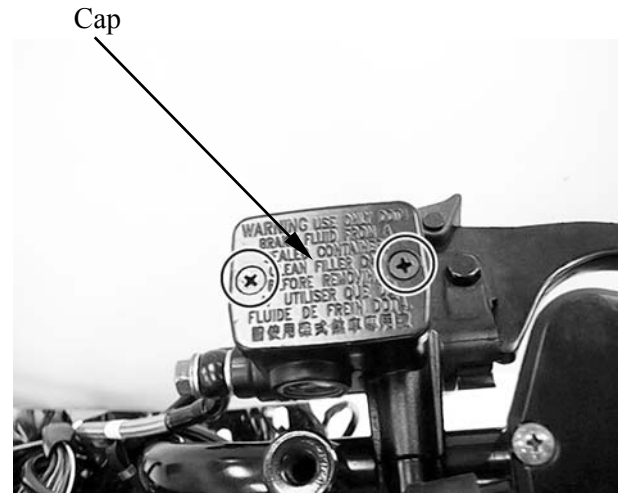

3. Connect a transparent hose to the delay valve bleed valve and then loosen the bleed valve nut. Use a syringe to draw the brake fluid out through the hose. Then tighten the bleed valve nut.

Torque: 0.6 kgf-m (6 Nm, 4.32 lbf-ft)



16. BRAKE SYSTEM

4. Remove the brake fluid reservoir cap (brake pedal).

*

Use shop towels to cover plastic parts and coated surfaces to avoid damage caused by splash of brake fluid.

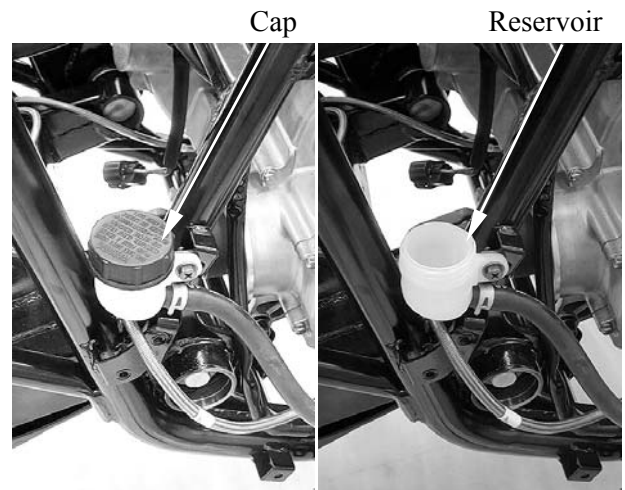

5. Connect a transparent hose to the front brake caliper bleed valve (front right and left calipers) and then loosen the bleed valve nut. Use a syringe to draw the brake fluid out through the hose. Then tighten the bleed valve nuts.

Torque: 0.6 kgf-m (6 Nm, 4.32 lbf-ft)

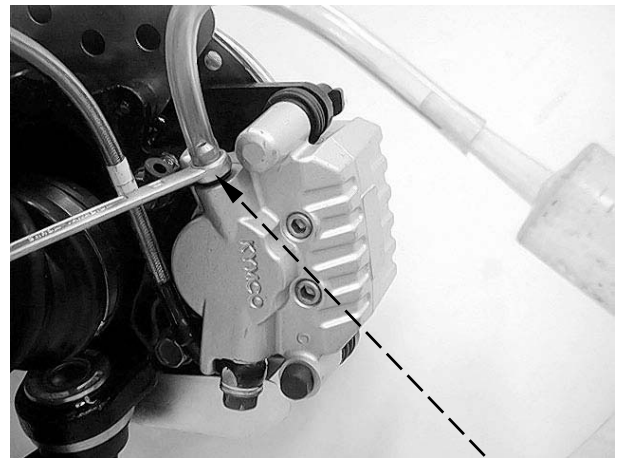

Bleed Valve Nut

6. Connect a transparent hose to the rear brake caliper bleed valve (combined) and then loosen the bleed valve nut. Use a syringe to draw the brake fluid out through the hose. Then tighten the bleed valve nut.

Torque: 0.6 kgf-m (6 Nm, 4.32 lbf-ft)

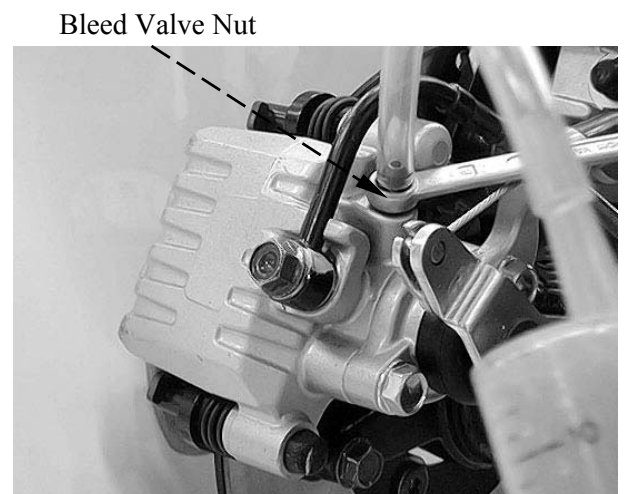

Bleed Valve Nut

16. BRAKE SYSTEM

7. Fill the brake reservoir (front brake lever) with brake fluid.

Reservoir



8. Loosen the delay valve bleed valve nut. Connect the transparent hose to the bleed valve. Use the syringe to draw brake fluid into it until there is no air bubbles in the transparent hose. Then, tighten the bleed valve nut.

Torque: 0.6 kgf-m (6 Nm, 4.32 lbf-ft)

*

- When drawing brake fluid with the syringe, the brake fluid level should be kept over 1/2 of the brake reservoir height (front brake lever).
- Use only the recommended brake fluid.

Recommended Brake Fluid: DOT-4

Bleed Valve



9. Fill the brake reservoir (brake pedal) with brake fluid.

Reservoir



16. BRAKE SYSTEM

10. Connect a transparent hose to the right caliper bleed valve and then loosen the bleed valve nuts.
Use the syringe to draw brake fluid into it until there is no air bubbles in the transparent hose.
Then, tighten the bleed valve nut.

Torque: 0.6 kgf-m (6 Nm, 4.32 lbf-ft)

Connect a transparent hose to the left caliper bleed valve and then loosen the bleed valve nuts.
Use the syringe to draw brake fluid into it until there is no air bubbles in the transparent hose.
Then, tighten the bleed valve nut.

Torque: 0.6 kgf-m (6 Nm, 4.32 lbf-ft)

- *
 - When drawing brake fluid with the syringe, the brake fluid level should be kept over 1/2 of the brake reservoir height (brake pedal).
 - Use only the recommended brake fluid.

Recommended Brake Fluid: DOT-4

11. Loosen the rear caliper (combined) bleed valve nut. Connect the transparent hose to the bleed valve.
Use the syringe to draw brake fluid into it until there is no air bubbles in the transparent hose.
Then, tighten the bleed valve nut.

Torque: 0.6 kgf-m (6 Nm, 4.32 lbf-ft)

- *
 - When drawing brake fluid with the syringe, the brake fluid level should be kept over 1/2 of the brake reservoir height (brake pedal).
 - Use only the recommended brake fluid.

Recommended Brake Fluid: DOT-4

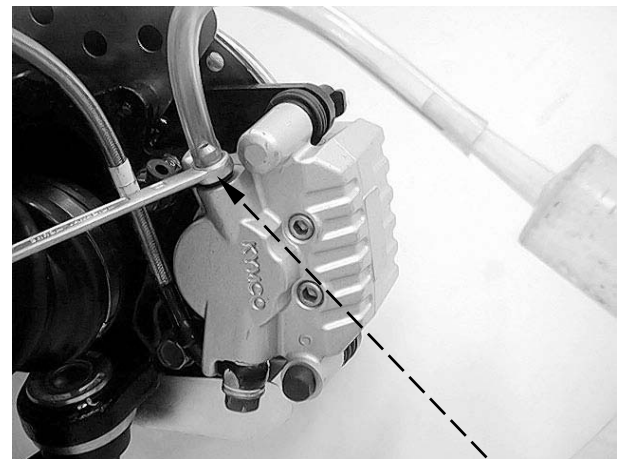

Bleed Valve Nut

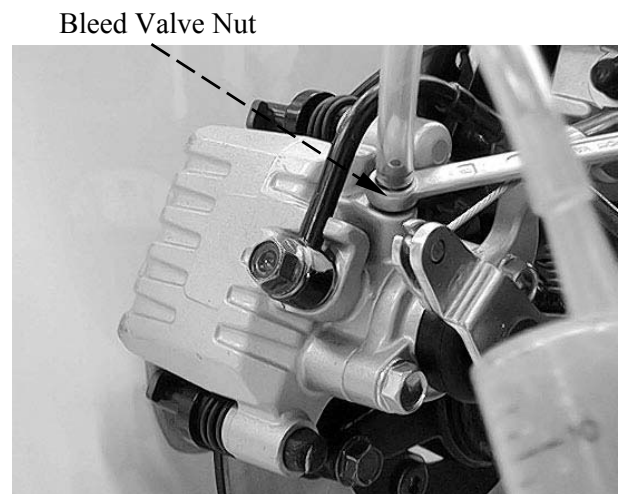

Bleed Valve Nut

16. BRAKE SYSTEM

DELAY VALVE BLEEDING

1. Connect a transparent hose to the bleed valve (delay valve).
2. Fully apply the front brake lever after continuously pull it several times. Then, loosen the bleed valve nut (delay valve) to bleed air between the front brake master cylinder and the delay valve.
3. Repeat these steps until between the front brake master cylinder and the delay valve is free of air. Then tighten the bleed valve nut.

Bleed Valve



Torque: 0.6 kgf-m (6 Nm, 4.32 lbf-ft)

* When bleeding air from the brake system, the brake fluid level should be kept over 1/2 of the brake reservoir height (front brake lever).

COMBINATION BRAKE SYSTEM AIR BLEEDING

1. To finish delay valve bleeding (refer to above).
2. Connect a transparent hose to the rear caliper (combined) and front calipers bleed valves.
3. Fully apply the brake pedal after continuously depress it several times and fully apply the front brake lever after continuously pull it several times. Then, loosen the rear caliper bleed valve nut to bleed air from the brake system.
4. Fully apply the brake pedal after continuously depress it several times and fully apply the front brake lever after continuously pull it several times. Then, loosen the front right caliper bleed valve nut to bleed air from the brake system.
5. Fully apply the brake pedal after continuously depress it several times and fully apply the front brake lever after continuously pull it several times. Then, loosen the front left caliper bleed valve nut to bleed air from the brake system.

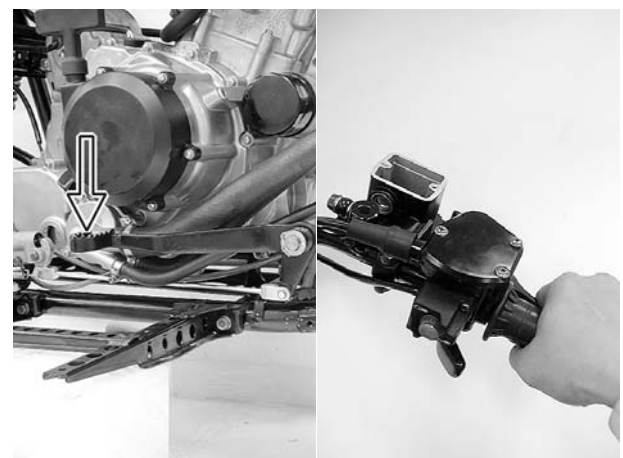

16. BRAKE SYSTEM

- Repeat these steps until the brake system is free of air. Then tighten the bleed valve nuts.

Torque: 0.6 kgf-m (6 Nm, 4.32 lbf-ft)

*

When bleeding air from the brake system, the brake fluid level should be kept over 1/2 of the brake reservoir height (brake pedal).

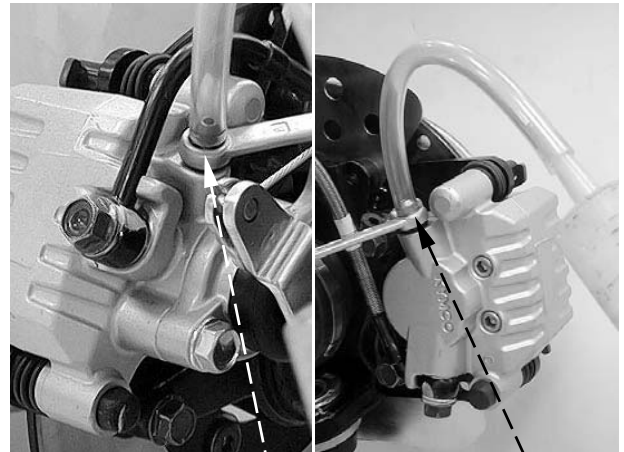

Bleed Valve

Bleed Valve

16. BRAKE SYSTEM

BRAKE MASTER CYLINDERS REMOVAL/INSPECTION/ INSTALLATION

REMOVAL

Front/rear master cylinder

Remove the brake reservoir cap and drain the brake fluid from the hydraulic brake system (refer to the “**FRONT BRAKE FLUID CHANGE/AIR BLEED (OFF ROAD)**” section or “**REAR BRAKE FLUID CHANGE/AIR BLEED**” section or “**COMBINATION BRAKE FLUID CHANGE/AIR BLEED (ON ROAD)**” in this chapter).

* Do not splash brake fluid onto any rubber, plastic and coated parts. When working with brake fluid, use shop towels to cover these parts.

Remove the bolt/nut and then remove the brake lever.

Remove fluid hose bolt/two washers and then disconnect the fluid hose.

* When removing the brake fluid hose bolt, be sure to place towels under the hose and plug the hose end to avoid brake fluid leakage and contamination.

Remove the two master cylinder holder bolts and remove the master cylinder.



Brake Lever



16. BRAKE SYSTEM

Push the hole under the front brake master cylinder and then remove the brake light switch.

Remove the screw and then remove the brake light switch from the rear brake master cylinder.

Rear Brake Master Cylinder



Front Brake Master Cylinder

Brake pedal master cylinder

Remove the brake reservoir cap and drain the brake fluid from the hydraulic brake system (refer to the “**REAR BRAKE FLUID CHANGE/AIR BLEED**” section or “**COMBINATION BRAKE FLUID CHANGE/AIR BLEED (ON ROAD)**” section in this chapter).

* Do not splash brake fluid onto any rubber, plastic and coated parts. When working with brake fluid, use shop towels to cover these parts.

Remove the joint then disconnect the fluid hose from the master cylinder.

Remove the bolt/nut then remove the brake arm from the master cylinder.

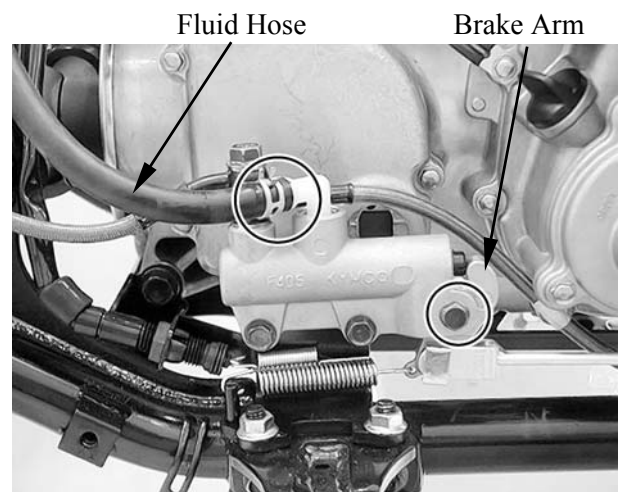

Remove fluid hose bolt/two washers and then disconnect the fluid hose.

* When removing the brake fluid hose bolt, be sure to place towels under the hose and plug the hose end to avoid brake fluid leakage and contamination.

Remove the two mounting bolts and remove the master cylinder.

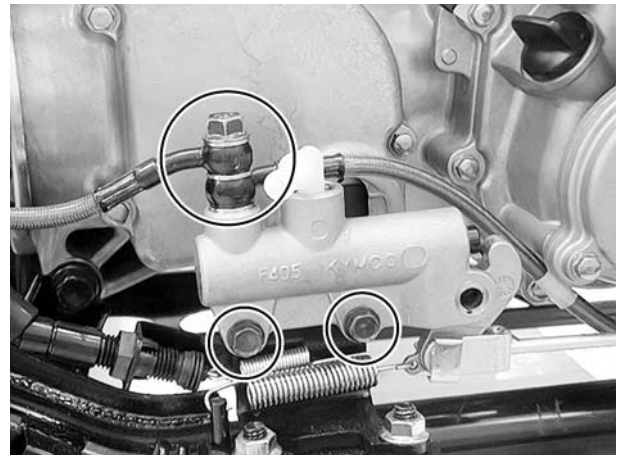

INSPECTION

Check the diaphragm to cracks or damage. If any damages are found, replace the diaphragm with a new one.



INSTALLATION

Front/rear master cylinder

Install the brake light switch.

Place the right and left brake master cylinder on the handlebar and install the master cylinder holder with the "UP" mark facing up, aligning the punch mark on the handlebar with the holder joint seam. First tighten the upper bolt and then tighten the lower blot.

Torque: 1.2 kg-m (12 Nm, 8.6 lbf-ft)



* Refer to the “**REAR PARKING SYSTEM**” section in this chapter to install the left master cylinder holder.

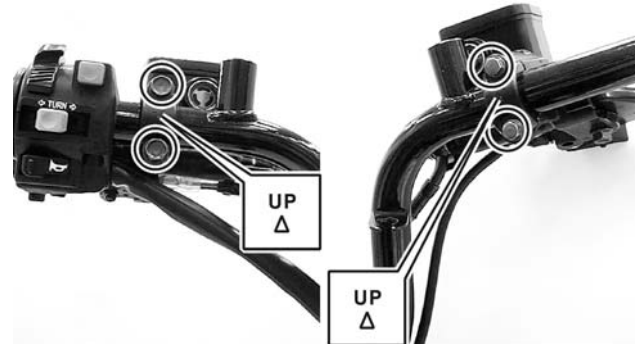

Install the brake fluid hose with the attaching bolt and two new sealing washers, then tighten the bolt to the specified torque.

Torque: 3.5 kgf-m (35 Nm, 25 lbf-ft)

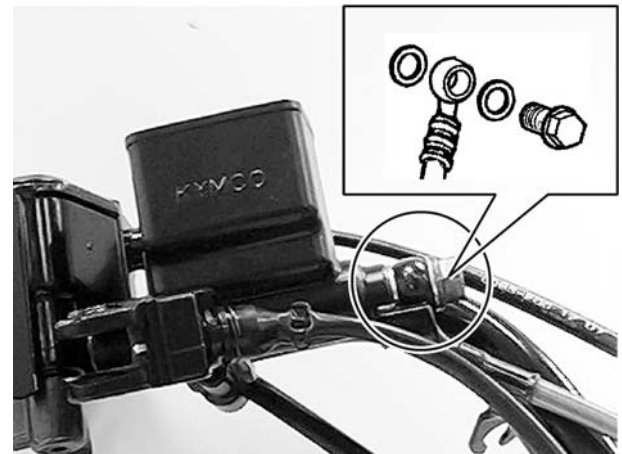

Apply lightweight lithium-soap base grease to the dust boot in the master cylinder, then install the brake lever.

Apply lightweight lithium-soap base grease to the bolt, then install and tighten the bolt and nut securely.

Fill the brake reservoir with the specified brake fluid and bleed air from the brake system (refer to the “**FRONT BRAKE FLUID CHANGE/AIR BLEED**” section or “**REAR BRAKE FLUID CHANGE/AIR BLEED**” section or “**COMBINATION BRAKE FLUID CHANGE/AIR BLEED**” section in this chapter).



Apply grease to the dust boot

Install the brake reservoir cap.

Brake pedal master cylinder

Install and tighten the two mounting bolts to the specified torque.

Torque: 1.2 kg-m (12 Nm, 8.6 lbf-ft)

Install the brake fluid hose (ON ROAD: two brake fluid hose) with the attaching bolt and two (ON ROAD: three) new sealing washers, then tighten the bolt to the specified torque.

Torque: 3.5 kgf-m (35 Nm, 25 lbf-ft)

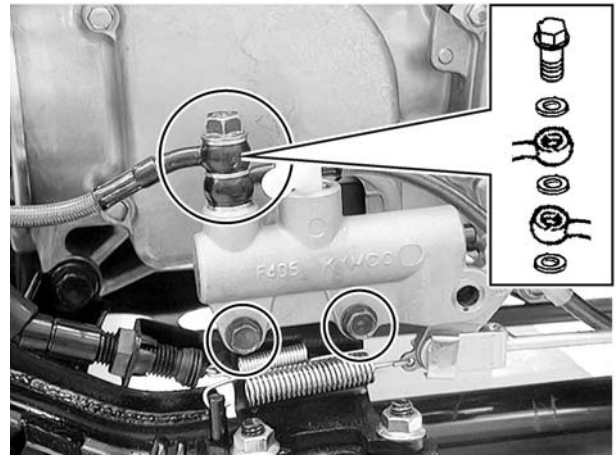

Apply lightweight lithium-soap base grease to the dust boot in the master cylinder, then install the brake arm.

Apply lightweight lithium-soap base grease to the bolt, then install and tighten the bolt and nut securely.

Connect the fluid hose to the master cylinder, then fix the joint.

Fill the brake reservoir with the specified brake fluid and bleed air from the brake system (refer to the “**COMBINATION BRAKE FLUID CHANGE/AIR BLEED**” section in this chapter).

Install the brake reservoir cap.

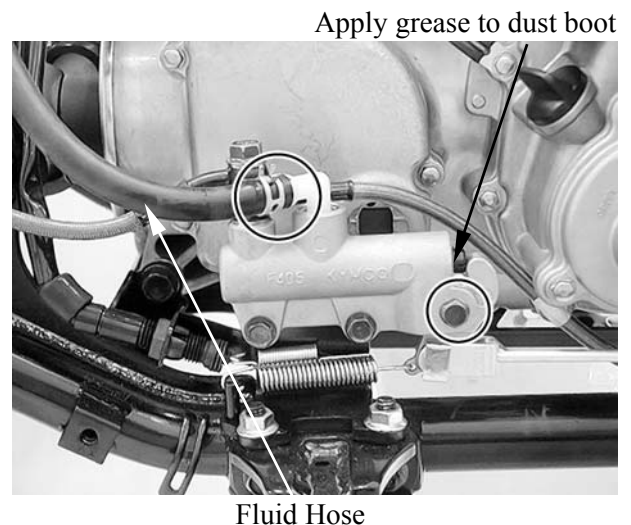

BRAKE MASTER CYLINDER DISASSEMBLY/INSPECTION/ ASSEMBLY

DISASSEMBLY

Front/rear brake master cylinder

Remove the brake master cylinder (refer to the “BRAKE MASTER CYLINDERS REMOVAL/INSTALLATION” section in this chapter).

Remove the piston dust boot and snap ring from the brake master cylinder.

Remove the spring and piston together.

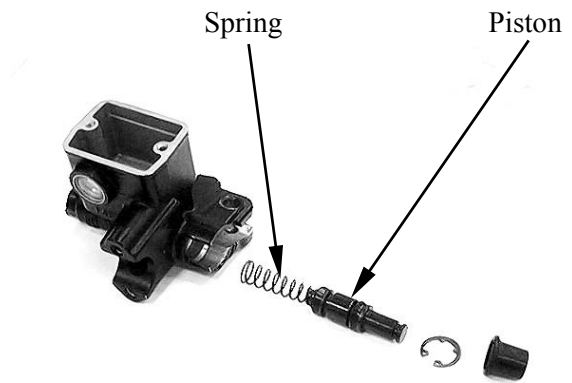
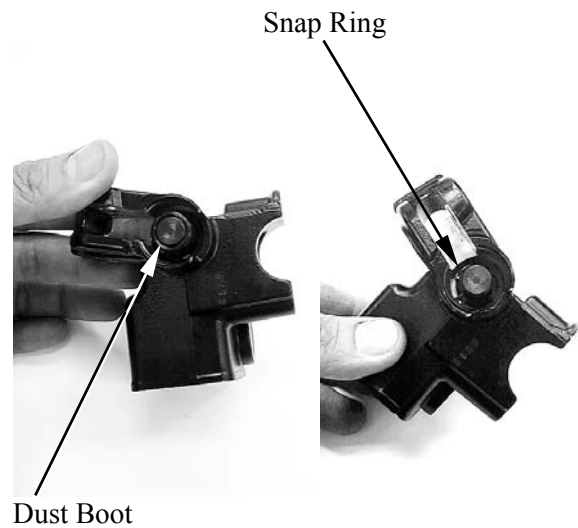

Brake pedal master cylinder

Remove the brake master cylinder (refer to the “BRAKE MASTER CYLINDERS REMOVAL/INSTALLATION” section in this chapter).

Remove the snap ring then remove the fluid duct and O-ring.

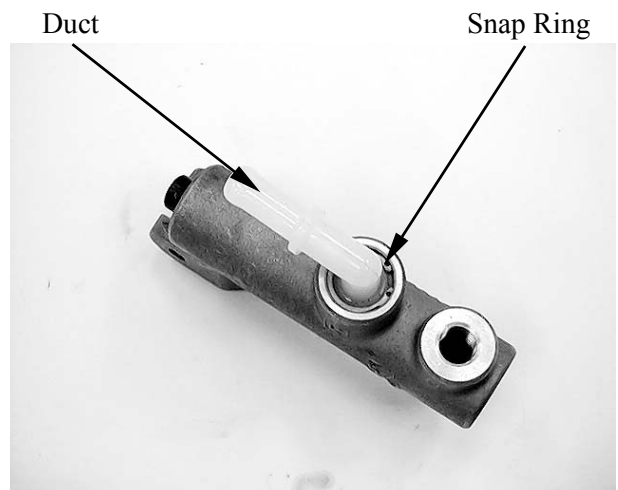

Remove the dust boot.
Remove the snap ring, then remove the piston and spring together.

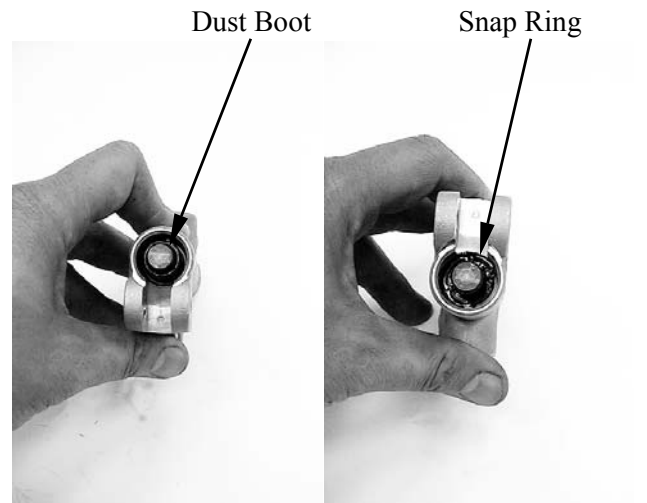

INSPECTION

Check the cylinder inside wall for scratch, corrosion or other abnormal condition.

If any abnormal condition is found, replace the master cylinder.

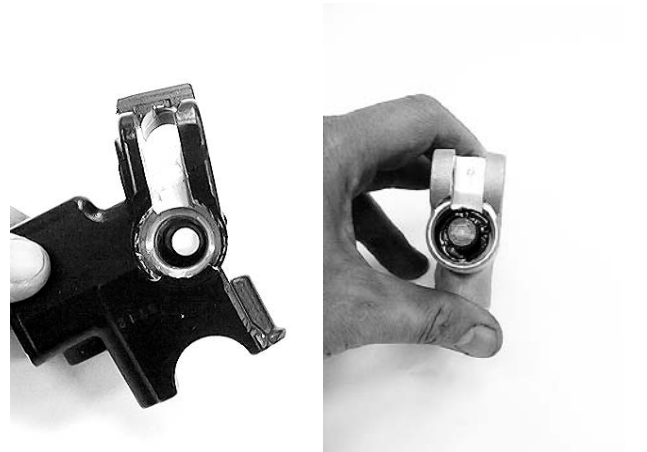

Check the spring and piston for scratch, corrosion or other abnormal condition.

If any abnormal condition is found, replace the parts.



ASSEMBLY

- *
- Wash the master cylinder components with new brake fluid before reassembly.
 - Do not wipe the brake fluid off with a rag after washing the components.
 - When washing the components, use the specified brake fluid (DOT 4). Never use different types of fluid or cleaning solvents such as gasoline, kerosine, etc.
 - Apply brake fluid to the master cylinder bore and all the component to be inserted to the bore.

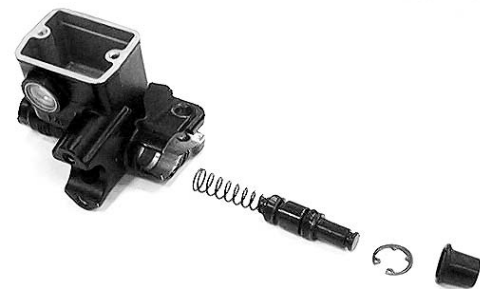

Front/rear brake master cylinder

Install the spring/piston.
Install the snap ring.
Install a new dust boot.

Brake pedal master cylinder

Install the spring/piston.
Install the snap ring.
Install a new dust boot.

Install a new O-ring.
Install the fluid duct.
Install the snap ring.

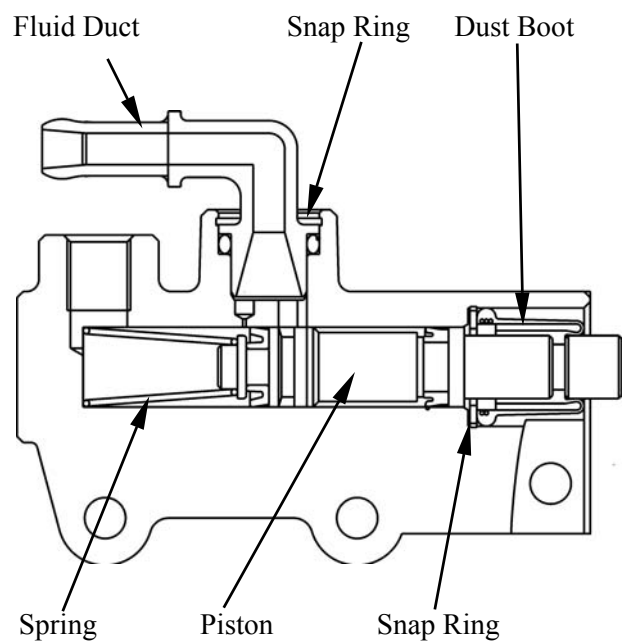

RELAY VALVE REMOVAL/DISASSEMBLY/INSPECTION/ASSEMBLY/ INSTALLATION (ON ROAD)

REMOVAL

Drain brake fluid (refer to the “**COMBINATION BRAKE FLUID CHANGE/AIR BLEED (ON ROAD)**” section in this chapter).

- * Do not splash brake fluid onto any rubber, plastic and coated parts. When working with brake fluid, use shop towels to cover these parts.

Remove all fluid hoses bolts/washers and then disconnect the all fluid hoses.

- * When removing the brake fluid hose bolt, be sure to place towels under the hose and plug the hose end to avoid brake fluid leakage and contamination.

Remove the two mounting bolts and remove the relay valve.

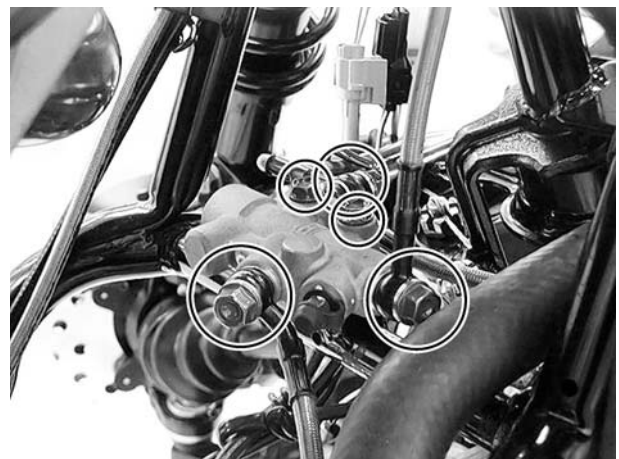

DISASSEMBLY

Remove the bolt.

Remove the spring.

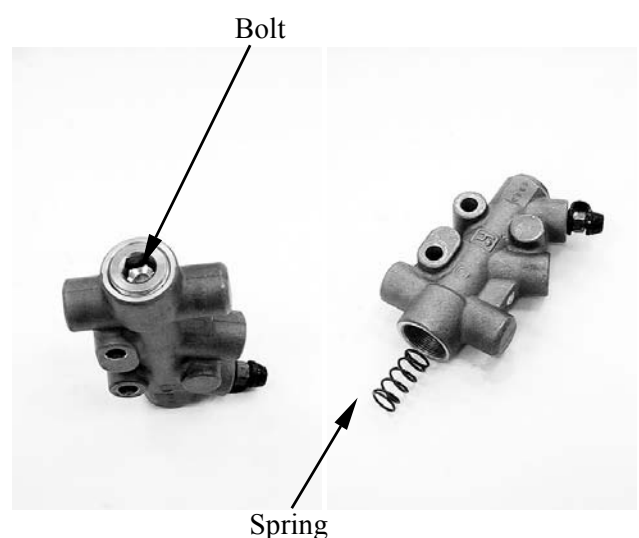

Push the piston out with a screwdriver.

INSPECTION

Check the delay valve body inside wall for scratch, corrosion or other abnormal condition.

If any abnormal condition is found, replace the delay valve.

Check the spring and piston for scratch, corrosion or other abnormal condition.

If any abnormal condition is found, replace the parts.

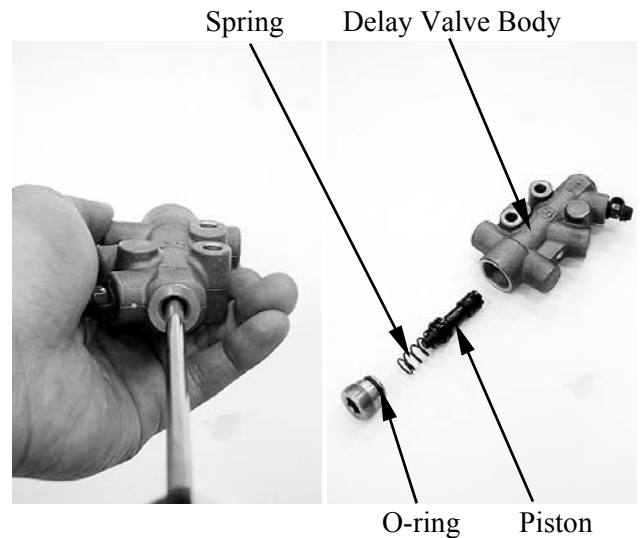

ASSEMBLY

- * Wash the delay valve components with new brake fluid before reassembly.
- * Do not wipe the brake fluid off with a rag after washing the components.
- * When washing the components, use the specified brake fluid (DOT 4). Never use different types of fluid or cleaning solvents such as gasoline, kerosine, etc.
- * Apply brake fluid to the delay valve bore and all the component to be inserted to be inserted to the bore.

Install the piston.

Install the spring.

Replace a new O-ring then install and tighten the bolt to the specified torque.

Torque: 5 kgf-m (50 N-m, 36 lbf-ft)

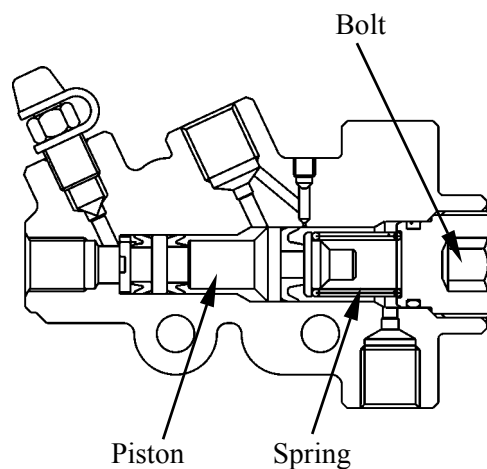

16. BRAKE SYSTEM

INSTALLATION

Install and tighten the mounting bolts to the specified torque.

Torque: 1.2 kgf-m (12 Nm, 8.6 lbf-ft)

Install the all brake fluid hoses with the attaching bolts and new sealing washers, then tighten the bolts to the specified torque.

Torque: 3.5 kgf-m (35 Nm, 25 lbf-ft)

Fill the specified brake fluid and bleed air from the brake system (refer to the “**COMBINATION BRAKE FLUID CHANGE/AIR BLEED**” section in this chapter).

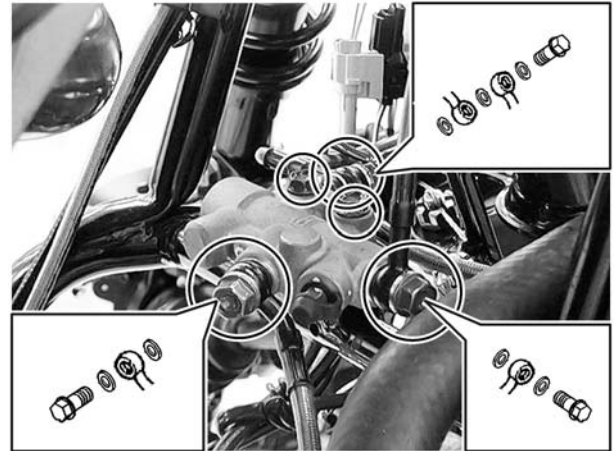

FRONT BRAKE CALIPERS REMOVAL/INSTALLATION

REMOVAL

Drain the brake fluid from the hydraulic brake system (refer to the “**FRONT BRAKE FLUID CHANGE/AIR BLEED (OFF ROAD)**” section or “**COMBINATION BRAKE FLUID CHANGE/AIR BLEED (ON ROAD)**” section in this chapter).

Remove the brake fluid hose bolt and two washers from the caliper.

Remove the brake pads (refer to the “**BRAKE PADS REPLACEMENT**” section in this chapter).

Remove the brake caliper.

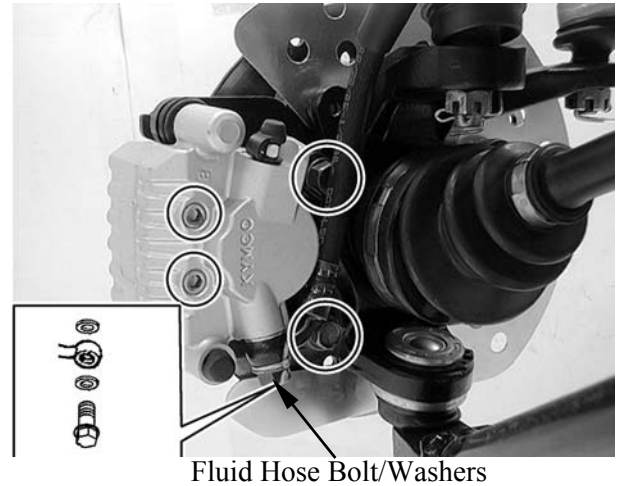

INSTALLATION

Install the brake fluid hose with the attaching bolt and two new sealing washers, then tighten the bolt to the specified torque.

Torque: 3.5 kgf-m (35 Nm, 25 lbf-ft)

Fill the specified brake fluid and bleed air from the brake system (refer to the “**FRONT BRAKE FLUID CHANGE/AIR BLEED** ” section or “**COMBINATION BRAKE FLUID CHANGE/AIR BLEED** ” section in this chapter).

REAR BRAKE CALIPERS REMOVAL/INSTALLATION

Drain the brake fluid from the hydraulic brake system (refer to the “**REAR BRAKE FLUID CHANGE/AIR BLEED**” section in this chapter).

Remove the brake fluid hose bolt and two washers from the caliper.

Remove the brake pads (refer to the “**BRAKE PADS REPLACEMENT**” section in this chapter).

Remove the brake caliper.



INSTALLATION

Install the brake fluid hose with the attaching bolt and two new sealing washers, then tighten the bolt to the specified torque.

Torque: 3.5 kgf-m (35 Nm, 25 lbf-ft)

Fill the specified brake fluid and bleed air from the brake system (refer to the “**REAR BRAKE FLUID CHANGE/AIR BLEED**” section in this chapter).



REAR BRAKE/PARKING BRAKE CALIPER REMOVAL/INSTALLATION

Drain the brake fluid from the hydraulic brake system (refer to the “**COMBINATION BRAKE FLUID CHANGE/AIR BLEED**” section in this chapter).

Disconnect the parking brake cable from the caliper.

Remove the brake fluid hose bolt and two washers from the caliper.

Remove the brake pads (refer to the “**BRAKE PADS REPLACEMENT**” section in this chapter).

Remove the brake caliper.

INSTALLATION

Install the brake fluid hose with the attaching bolt and two new sealing washers, then tighten the bolt to the specified torque.

Torque: 3.5 kgf-m (35 Nm, 25 lbf-ft)

Connect the parking brake cable.

Fill the specified brake fluid and bleed air from the brake system (refer to the “**COMBINATION BRAKE FLUID CHANGE/AIR BLEED**” section in this chapter).

Adjust the parking brake lever (refer to the “**PARKING BRAKE ADJUSTMENT**” section in the chapter 3).

Parking Brake Cable

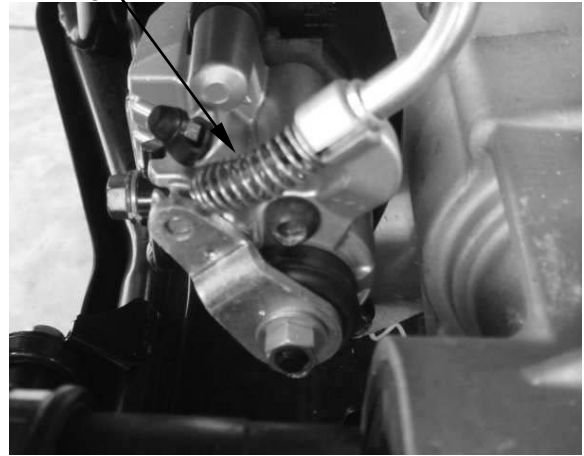

BRAKE CALIPER DISASSEMBLY/INSPECTION/ ASSEMBLY

DISASSEMBLY

Remove the front or rear brake caliper (refer to the “**FRONT BRAKE CALIPERS REMOVAL/INSTALLATION**” section or “**REAR BRAKE CALIPERS REMOVAL/INSTALLATION**” section in this chapter).

Remove the brake pad spring plate.

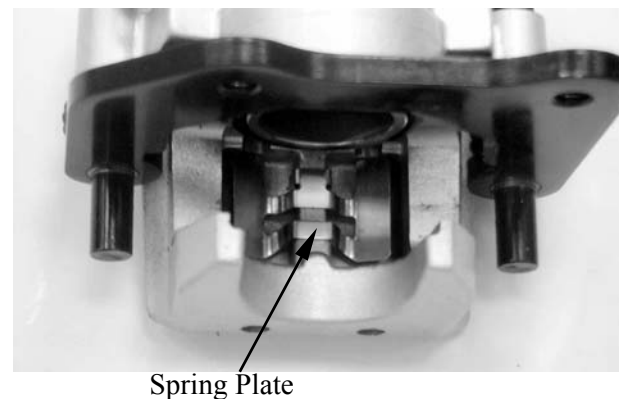

Remove the piston from the brake caliper. If necessary, use compressed air to squeeze out the piston through the brake fluid inlet opening and place a shop towel under the caliper to avoid contamination caused by the removed piston.



Push the piston dust seal inward to remove.

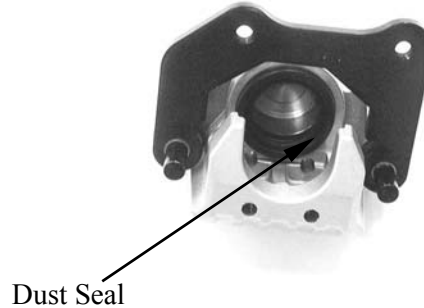

Pushing the piston oil seal outward to remove it.

Clean the seals groove with brake fluid.

* Be careful not to damage the piston surface.

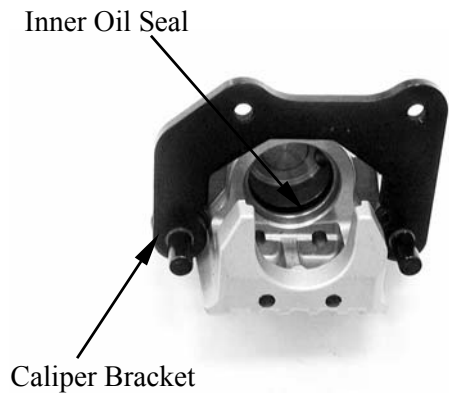

Remove the caliper bracket.

INSPECTION

Inspect the caliper cylinder wall and piston surface for scratch, corrosion or other damages.

If any abnormal condition is noted, replace the caliper.

Inspect the dust boots for deterioration or damage.

If any damages are found, replace them with a new one.



ASSEMBLY

- *
 - Wash the brake caliper components with new brake fluid before reassembly.
 - Do not wipe the brake fluid off with a rag after washing the components.
 - When washing the components, use the specified brake fluid (DOT 4). Never use different types of fluid or cleaning solvents such as gasoline, kerosine, etc.
 - Apply brake fluid to all of the seals, brake caliper bore and piston before reassembly.



Apply silicone grease to the caliper bracket pins.

REAR BRAKE/PARKING BRAKE CALIPER DISASSEMBLY/INSPECTION/ ASSEMBLY

DISASSEMBLY/INSPECTION

Remove parking brake caliper (refer to the “**REAR BRAKE/PARKING BRAKE CALIPER REMOVAL/INSTALLATION**” section in this chapter).

Remove the brake pad spring plate.



Spring Plate

Remove the piston from the brake caliper. If necessary, use compressed air to squeeze out the piston through the brake fluid inlet opening and place a shop towel under the caliper to avoid contamination caused by the removed piston.

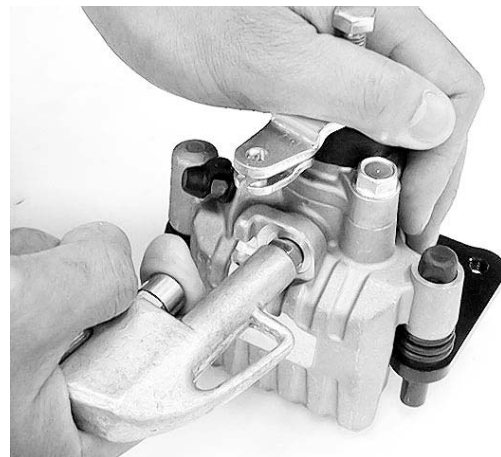

Inspect the caliper cylinder wall and piston surface for scratch, corrosion or other damages. If any abnormal condition is noted, replace the caliper.



16. BRAKE SYSTEM

Inspect the dust boots for deterioration or damage.

If any damages are found, replace them with a new ones.

Remove the caliper bracket.

Remove the dust boot.

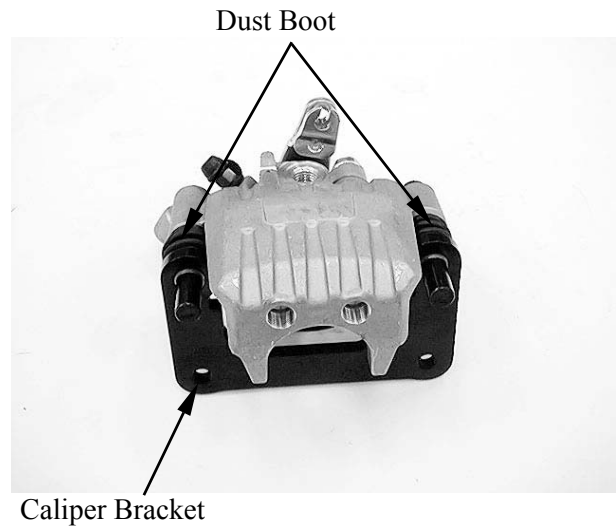

Remove the dust seal and piston seal.

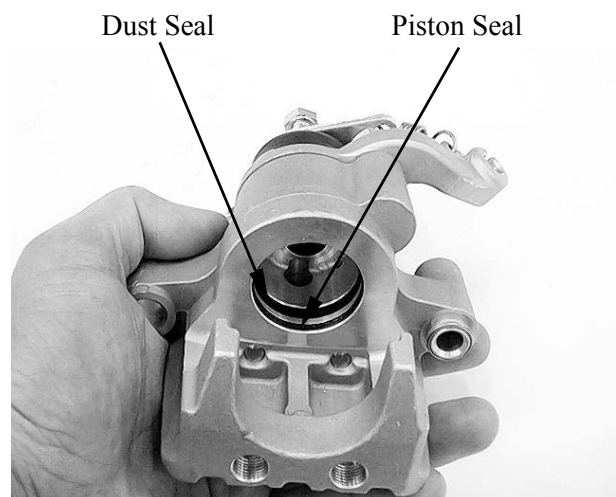

Loosen the lock nut while hold the adjusting bolt.

Remove the adjusting bolt.

Remove the parking brake arm and spring.

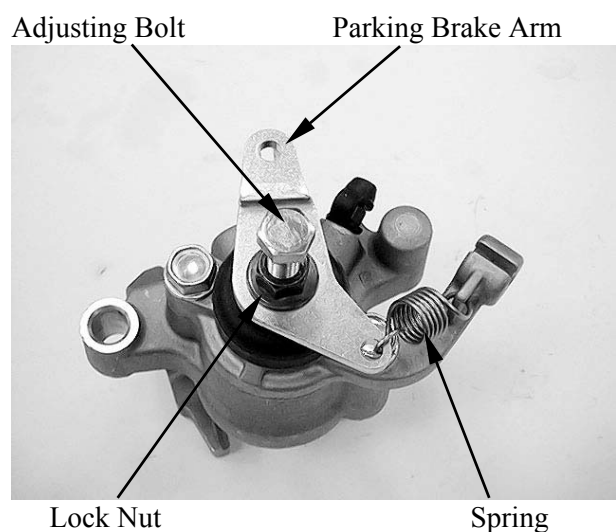

16. BRAKE SYSTEM

Inspect the dust boot for deterioration or damage.

If any damage is found, replace it with a new one.

Remove the drive bolt and dust boot.



Inspect the drive shaft and shaft guide for wear or damage.

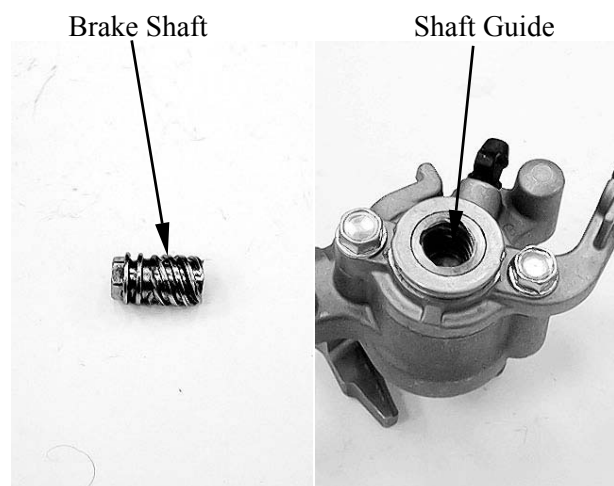

Remove the two bolts and parking brake case.



Remove the O-ring.

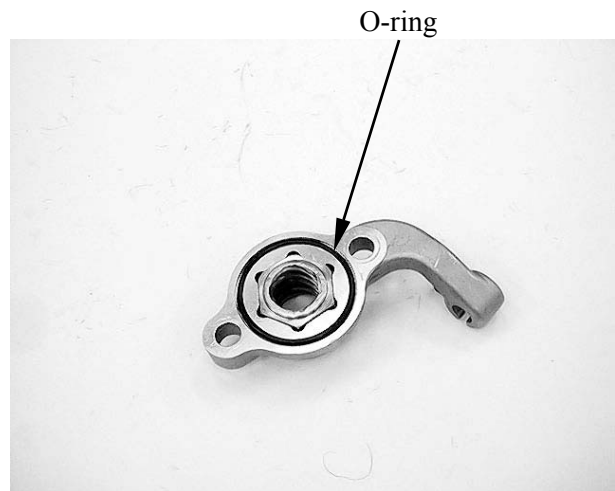

Inspect the O-ring for wear or damage.
If any damages are found, replace it with a new one.

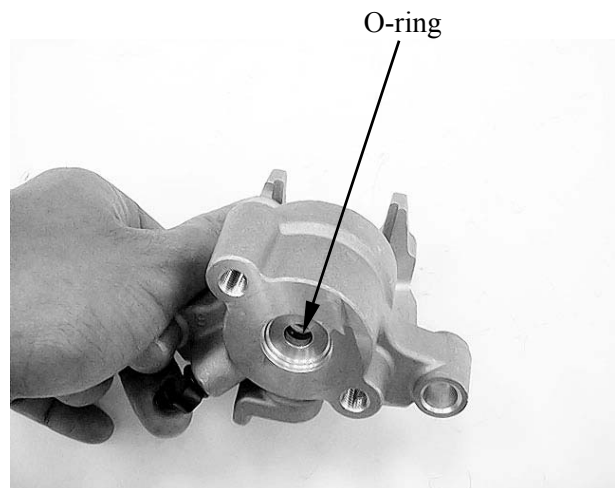

INSTALLATION

Apply silicone grease to the new O-ring, then install the new O-ring.

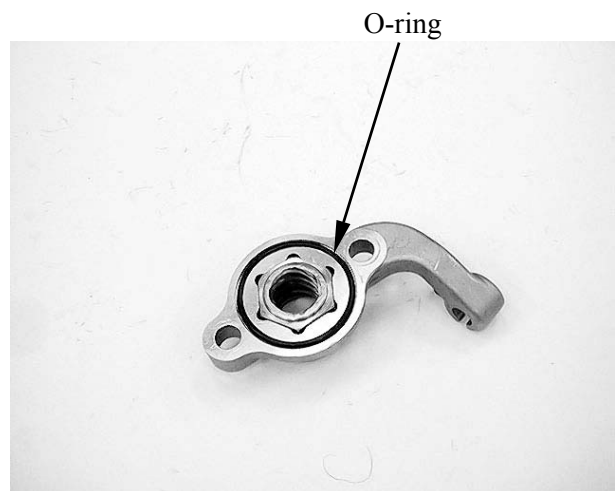

16. BRAKE SYSTEM

Install the parking brake case and two bolts.
Tighten the bolts securely.



Apply silicone grease to the new piston seal
and new dust seal, then install them.

Install the piston.

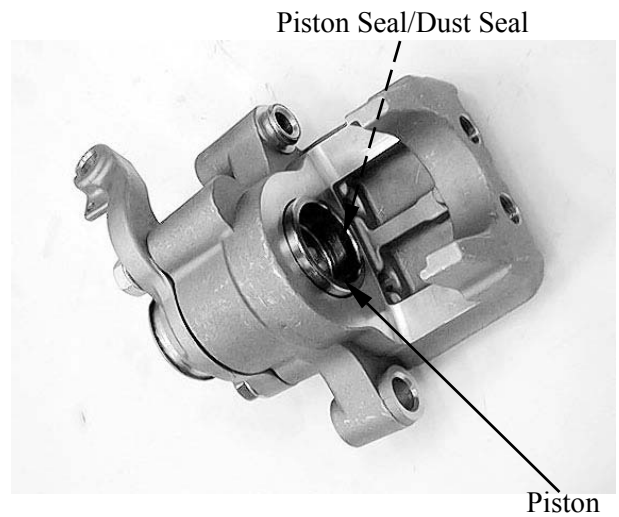

Apply silicone grease to the brake shaft, then
install it.

Apply silicone grease to the dust boot, then
install it.

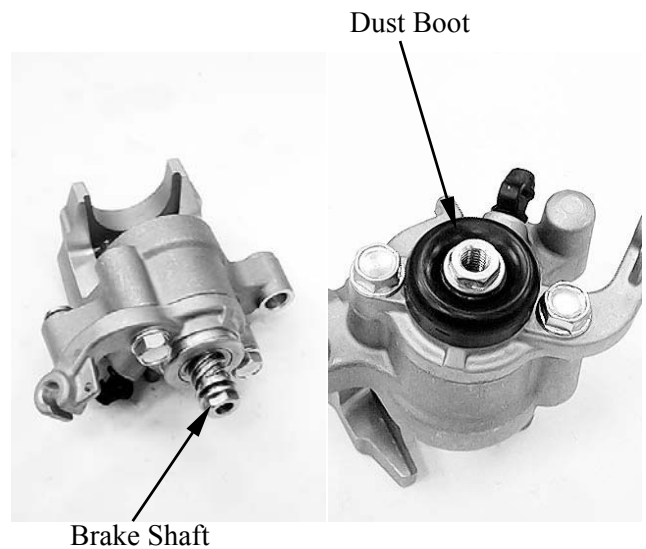

16. BRAKE SYSTEM

Press the piston and turn the brake shaft counterclockwise to expand boot, then the brake shaft does not touch piston.

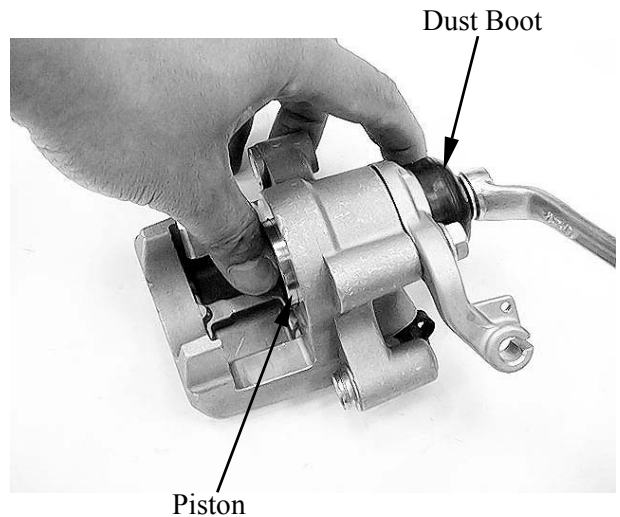

Install the parking brake arm and spring.

* Align the parking brake arm with the brake fluid inlet hole as shown.

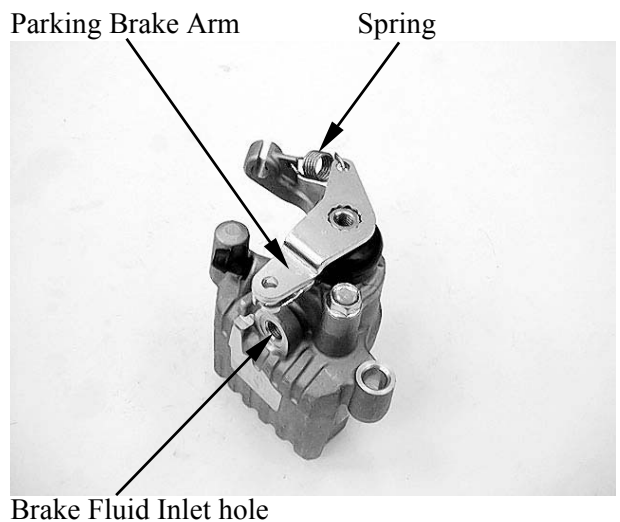

Install the adjusting bolt and lock nut.

* Do not turn in the adjusting too much and do not tighten the lock nut.

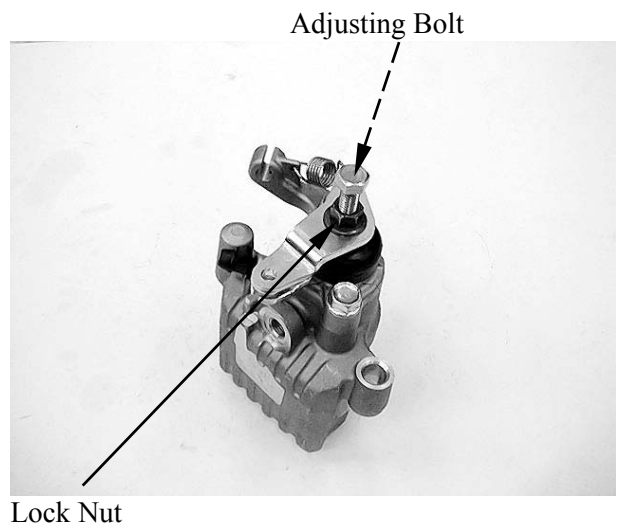

16. BRAKE SYSTEM

Install the dust boots.

Apply silicone grease to caliper bracket, then install it.

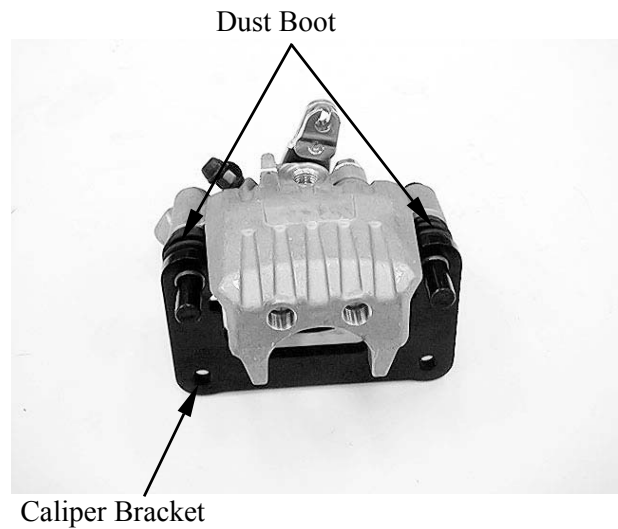

Install the spring plate.

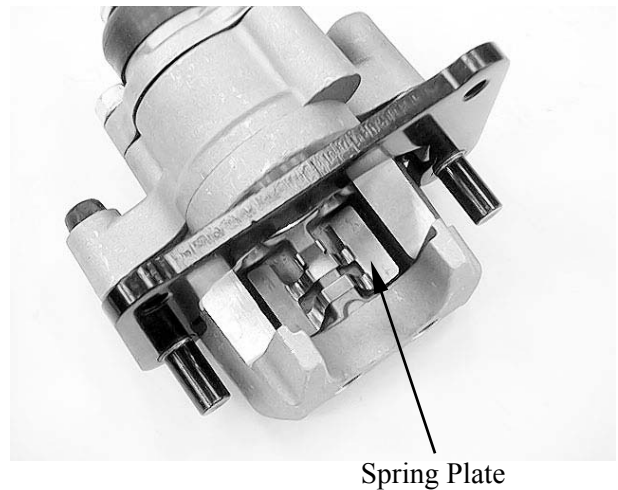

Install the parking brake caliper (refer to the “**REAR BRAKE/PARKING BRAKE CALIPER REMOVAL/INSTALLATION**” section in this chapter).

Adjust the parking brake (refer to the “**PARKING BRAKE ADJUSTMENT**” section in the chapter 3).

BATTERY/CHARGING SYSTEM

CHARGING SYSTEM LAYOUT/CHARGING CIRCUIT -----	17- 1
SERVICE INFORMATION-----	17- 2
BATTERY -----	17- 4
CHARGING SYSTEM INSPECTION -----	17- 5
ALTERNATOR CHARGING COIL-----	17- 6
REGULATOR/RECTIFIER-----	17- 7
ALTERNATOR STATOR REMOVAL/INSPECTION/ INSTALLATION -----	17-10

CHARGING SYSTEM LAYOUT



CHARGING CIRCUIT

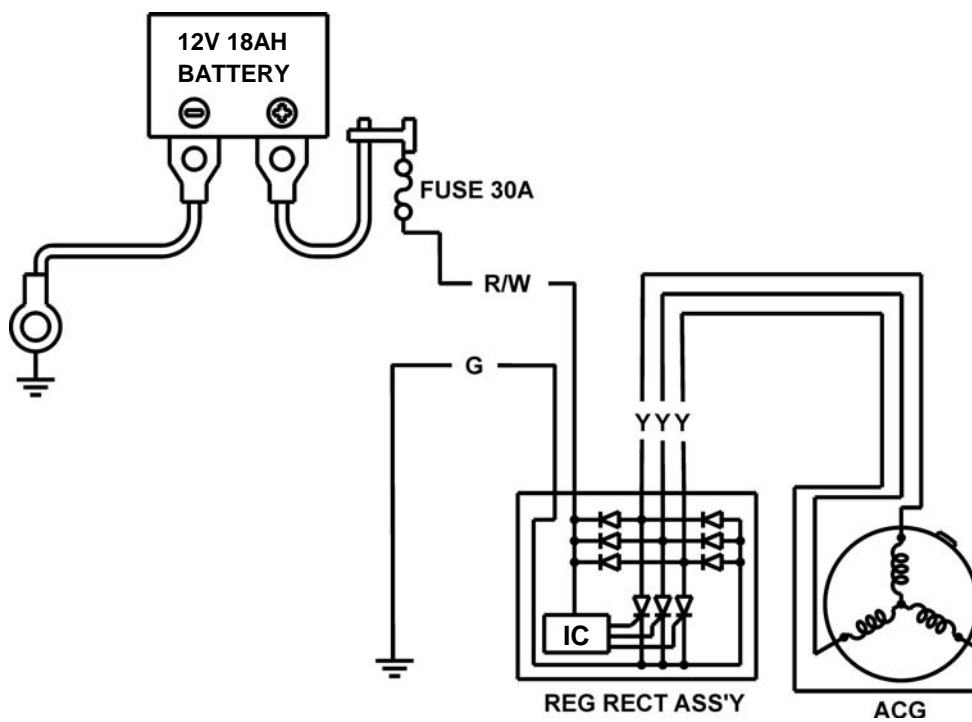

SERVICE INFORMATION**GENERAL****CAUTION**

- The battery gives off explosive gases; keep sparks, flames and cigarettes away. Provide adequate ventilation when charging.
- The battery contains sulfuric acid (electrolyte). Contact with skin or eyes may cause severe burns. Wear protective clothing and a face shield.
 - If electrolyte gets on your skin, flush with water.
 - If electrolyte gets in your eyes, flush with water for at least 15 minutes and call a physician immediately.
- Electrolyte is poisonous.
 - If swallowed, drink large quantities of water or milk and call your local Poison Control Center or physician immediately, **KEEP OUT OF REACH OF CHILDREN.**

- Always turn off the ignition switch before disconnecting any electrical component.
- Some electrical components may be damaged if terminals or connectors are connected or disconnected while the ignition switch is turned to “ON” and current is present.
- For extended storage, remove the battery, give it a full charge, and store it in a cool, dry place.
- For a battery remaining in a shorted vehicle, disconnect the negative battery cable from the battery.
- The battery caps should not be removed. Attempting to remove the sealing caps from the cells may damage the battery.
- The maintenance free battery must be replaced when it reaches the end of its service life.
- The battery can be damaged if overcharged or undercharged, or if left to discharge for long period. These same conditions contribute to shortening the “life span” of the battery. Even under normal use, the performance of the battery deteriorates after 2-3 years.
- Battery voltage may recover after battery charging, but under heavy load, the battery voltage will drop quickly and eventually die out. For this reason, the charging system is often suspected as the problem. Battery overcharge often results from problems in the battery itself, which may appear to be an overcharging symptom. If one of the battery cells is shorted and battery voltage does not increase, the regulator/rectifier supplies excess voltage to the battery. Under these conditions, the electrolyte level goes down quickly.
- Before troubleshooting the charging system, check for proper use and maintenance of the battery. Check if the battery is frequently under heavy load, such as having the headlight and taillight on for long periods of time without riding the vehicle.
- The battery self-discharge when the vehicle is not in use, for this reason, charge the battery every 2 weeks to prevent sulfate from occurring.
- Filling a new battery with electrolyte will produce some voltage, but in order to achieve its maximum performance, always charge the battery. Also, the battery life is lengthened when it is initially charged.
- When checking the charging system, always follow the steps in the troubleshooting flow chart (page 17-4)

BATTERY CHARGING

- This model comes with a maintenance free (MF) battery. Remember the following about MF batteries.
 - Use only the electrolyte that comes with the battery.
 - Use all of the electrolyte
 - Seal the battery properly
 - Never open the seals again
- For battery charging, do not exceed the charging current and time specified on the battery. Using excessive current or extending the charging time may damage the battery.

SPECIFICATIONS

ITEM		SPECIFICATIONS	
Battery	Capacity	12V – 18 Ah	
	Current leakage	0.5 Ma max.	
	Voltage (20°C/68°F)	Full charged	13.0 – 13.2 V
		Needs charging	Below 12.3 V
	Charging current	Normal	1.8 A/5 – 10 h
Quick		9 A/1 h	
Alternator	Capacity	310 – 400 W/5000 rpm	
	Charging coil resistance (20°C/68°F)	0.1 – 0.3 Ω	

BATTERY

REMOVAL/INSTALLATION

BATTERY REMOVAL

1. Make sure the ignition switch is OFF.
2. Remove the seat (refer to the “**FRAME COVERS**” section in the chapter 2)
3. Release the rings and remove the rubber band (1).
4. Disconnect the negative (-) terminal lead (2) from the battery first, then disconnect the positive (+) terminal lead (3).
5. Remove the battery.

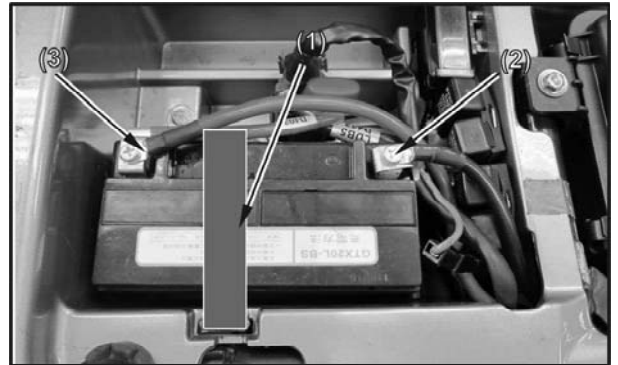

Battery installation

1. Install in the reverse order of removal.
2. After installing the battery, check to see if the battery cables are routed correctly.

After connecting the battery cables, coat the terminals with grease.

VOLTAGE INSPECTION

Remove the battery cover (see above).

Measure the battery voltage using a commercially available digital multi-meter.

Voltage (20°C/68°C):

- Fully charged: 13.0–13.2 V
- Under charged: below 12.3 V



BATTERY CHARGING

Remove the battery (see page 17-5).

Connect the charger positive (+) cable to the battery positive (+) terminal.

Connect the charger negative (-) cable to the battery negative (-) terminal.

* Turn the power ON/OFF at the charger, not at the battery terminals.

Charging current time:

Standard: 1.8 A/5 – 10 hours

Quick: 9 A/1 hours

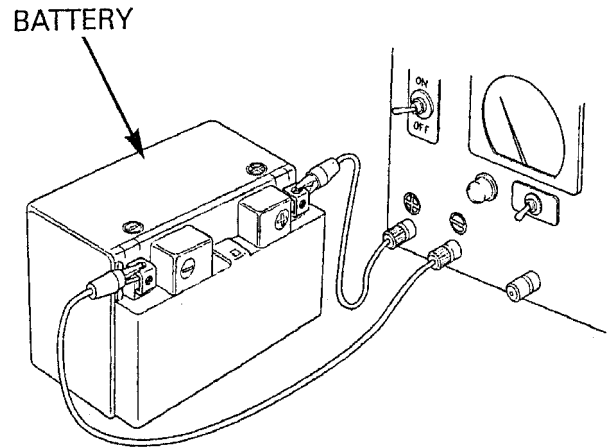

Quick charging should only be done in an emergency; slow charging is preferred.

For battery charging, do not exceed the charging current and time specified on the battery. Using excessive current or extending the charging time may damage the battery.

CHARGING SYSTEM INSPECTION

CURRENT LEAKAGE TEST

Turn the ignition switch OFF, disconnect the negative (-) cable from the battery.

Connect the ammeter (+) probe to the negative (-) cable and the ammeter (-) probe to the battery (-) terminal.

With the ignition switch OFF, check for current leakage.

When measuring current using a tester, set it to a high range, and then bring the range down to an appropriate level. Current flow higher than the range selected may blow out the fuse in the tester.

While measuring current, do not turn the ignition switch ON. A sudden surge of current may blow out the fuse in the tester.

Specified current leakage: 0.5 Ma max.

If current leakage exceeds the specified value, a shorted circuit is likely.

Locate the short by disconnecting connections one by one and measuring the current.

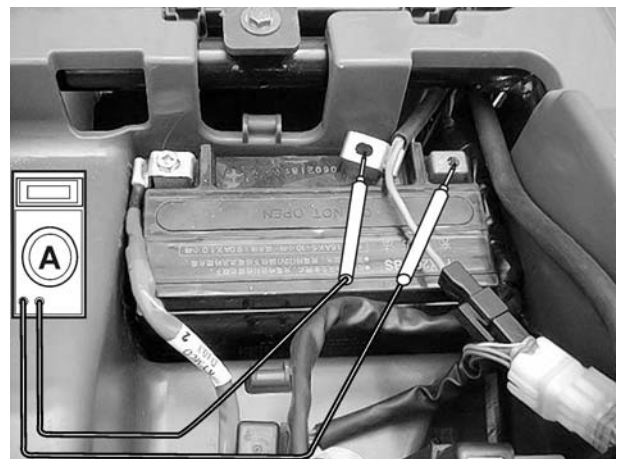

CHARGING VOLTAGE INSPECTION

Be sure that the battery is in good condition before performing this test.

- * Do not disconnect the battery or any cable in the charging system without first switching off the ignition switch. Failure to follow this precaution can damage the tester or electrical components.

Start the engine and warm it up to the operating temperature; stop the engine.

Connect the multi-meter between the positive and negative terminals of the battery.

To prevent short, make absolutely certain which are the positive and negative terminals or cable.

With the headlight on and turned to the high beam position, restart the engine.

Measure the voltage on the multi-meter when the engine runs at 5000 min (rpm).

Standard:

14.0±1.0V / 5000 rpm

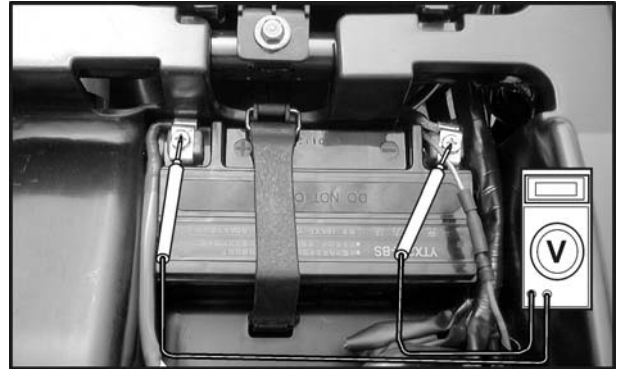

ALTERNATOR CHARGING COIL

INSPECTION

Disconnect the alternator connector.



Alternator Connector

Measure the resistance between each Yellow wire terminals.

Standard: 0.1 – 0.3 Ω (20°C/68°F)

Check for continuity between each Yellow wire terminal of the alternator side connector and ground.

There should be no continuity.

Replace the alternator stator if resistance is out of specification, or if any wire has continuity to ground.

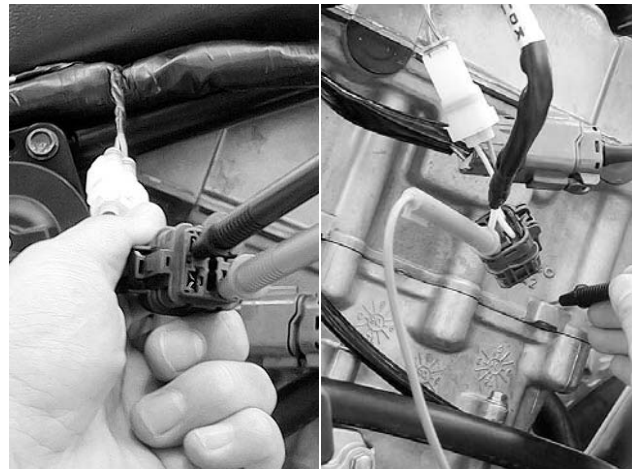

REGULATOR/RECTIFIER

WIRE HARNESS INSPECTION

Disconnect the regulator/rectifier connectors.
Check the connectors for loose contacts or corroded terminals.

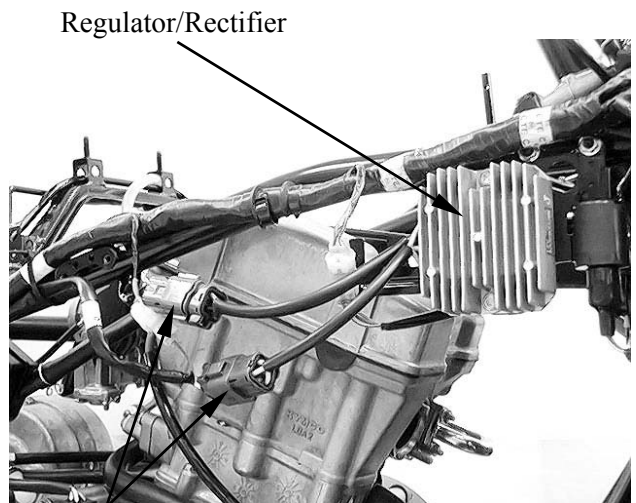

Regulator/Rectifier Connectors

Battery line

Measure the voltage between the Red/White wire terminal and ground.

There should be battery voltage at all times.

Voltage feedback line

Measure the voltage between the black wire terminal and ground.

There should be battery voltage with the ignition switch "ON", and no voltage with the ignition switch "OFF".



Ground line

Check the continuity between the Green wire terminal and ground.

There should be continuity at all times.

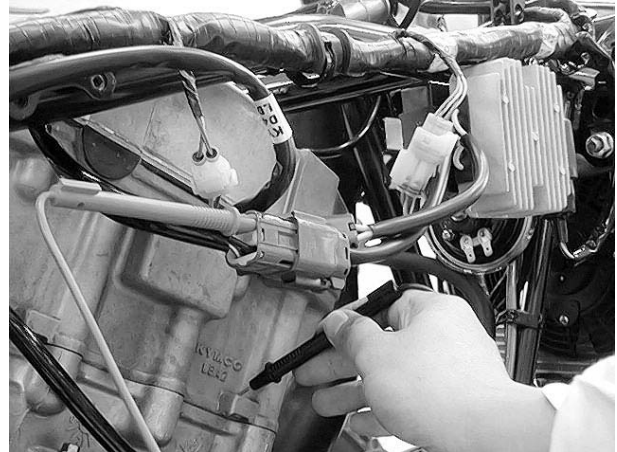

Charging coil line

Measure the resistance between each Yellow wire terminals.

Standard: 0.1 – 0.3 Ω (20°C/68°F)

Check for continuity between each Yellow wire terminal and ground.

There should be no continuity.



REMOVAL/INSTALLATION

Disconnect the regulator/rectifier connectors.

Remove the two bolts and then remove the regulator/rectifier.

Installation is in the reverse order of removal.

Regulator/Rectifier Connector

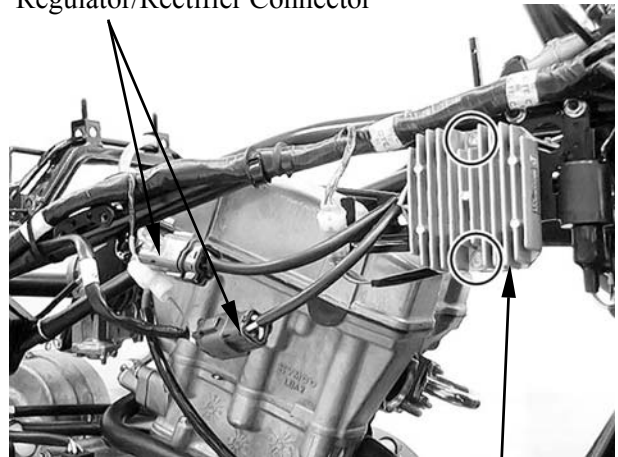

Regulator/Rectifier

ALTERNATOR STATOR REMOVAL/INSPECTION/ INSTALLATION

REMOVAL

Drain the engine oil (refer to the “**ENGINE OIL**” section in the chapter 3).

Disconnect the alternator stator connectors.

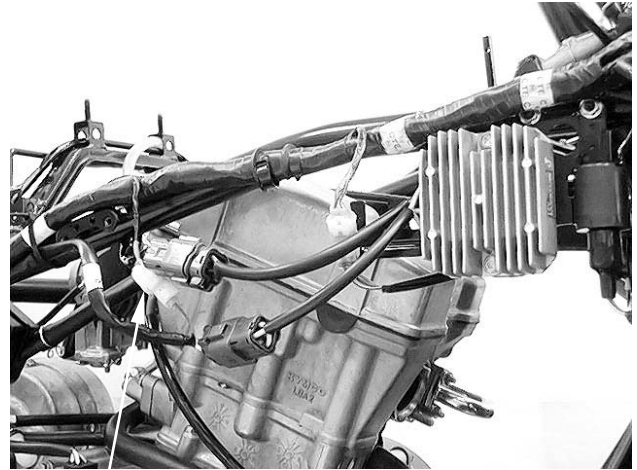

Alternator Stator Connectors

Remove the starter pulley (refer to the “**STARTER PULLEY REMOVAL/INSPECTION/INSTALLATION**” section in the chapter 19).

Remove the oil filler plug.

Oil Filler Plug

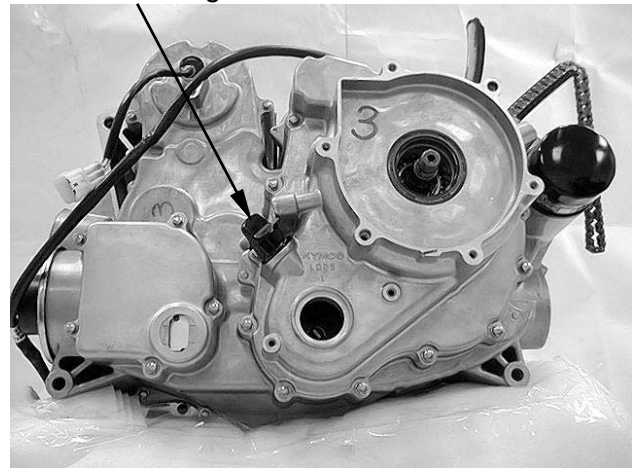

Remove the fourteen bolts and then remove the right crankcase cover.

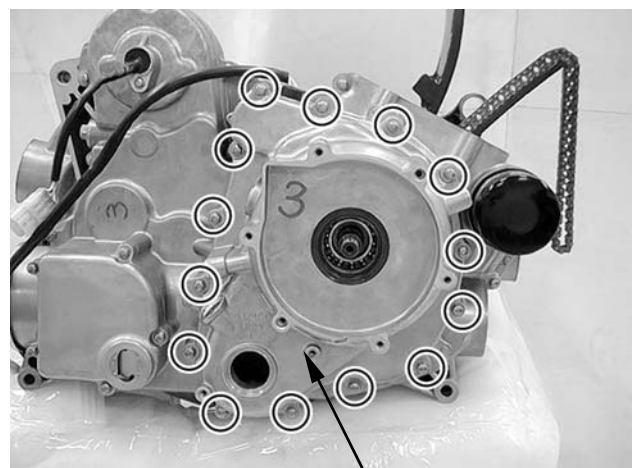

Right Crankcase Cover

17. BATTERY/CHARGING SYSTEM

MXU 550EXI/MXU500I

Remove the two dowel pins and gasket.

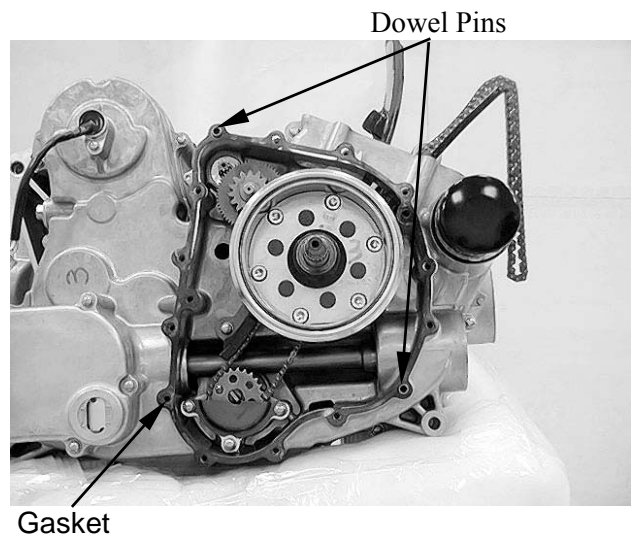

Remove the two pulse coil mount bolts. Remove the three stator mount bolts, grommet and the stator from the right crankcase cover.

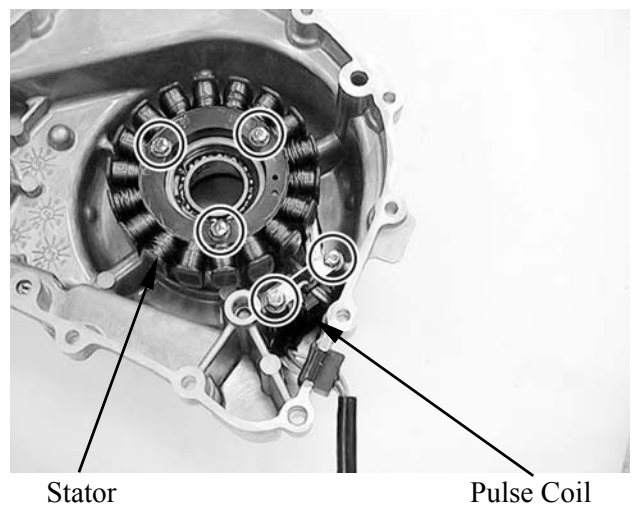

INSPECTION

Check the stator and pulse coil for damage.

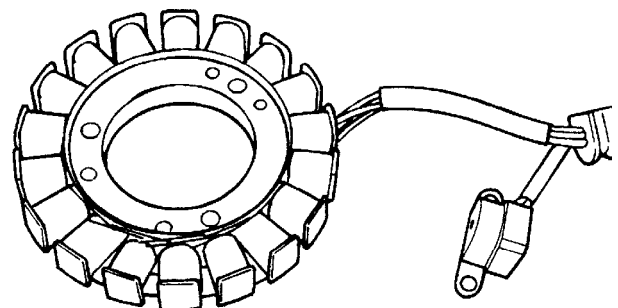

17. BATTERY/CHARGING SYSTEM

MXU 550EXI/MXU500I

INSTALLATION

Install the stator and tighten the stator mount bolts to the specified torque.

Torque: 1.2 kgf-m (12 N-m)

Apply sealant to the grommet seating surface and install it to the cover groove properly.

Install the pulse coil and tighten mount bolts to the specified torque.

Torque: 1.2 kgf-m (12 N-m)

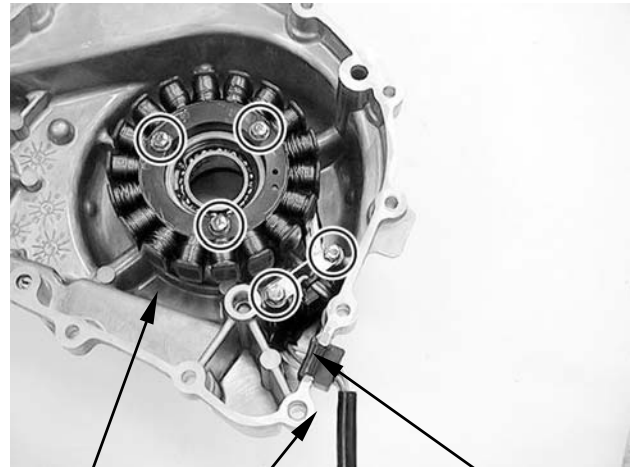

Stator Grommet Pulse Coil

Clean the mating surfaces of the right crankcase and cover.

Install the dowel pins and gasket.

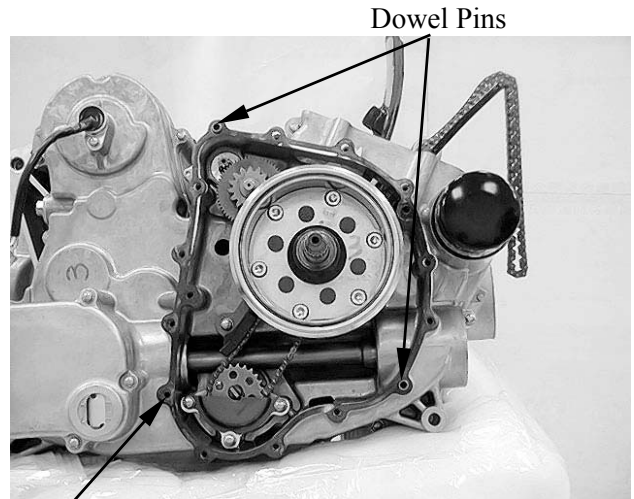

Gasket

Install the right crankcase cover and tighten the bolts in a crisscross pattern in 2 or 3 steps.

*** FLYWHEEL:**
Refer to the “**STARTER CLUTCH REMOVAL/INSPECTION/INSTALLATION**” section in the chapter 19

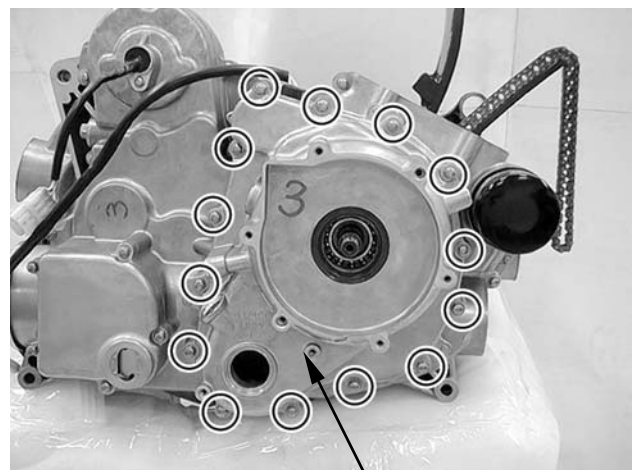

Right Crankcase Cover

18. LIGHTS/SWITCHES

LIGHTS / SWITCHES

SERVICE INFORMATION-----	18- 1
BULBS REMOVAL-----	18- 2
HORN (ON ROAD)-----	18- 4
IGNITION SWITCH-----	18- 5
HANDLEBAR SWITCH-----	18- 5
GEAR INDICATOR SWITCH-----	18- 8
SPEED SENSOR-----	18- 9
FUEL UNIT-----	18-10

18. LIGHTS / SWITCHES

SERVICE INFORMATION

- A continuity test can be made with the switches installed on the vehicle.
- All plastic connectors have locking tabs that must be released before disconnecting, and must be aligned when reconnecting.
- To isolate an electrical failure, check the continuity of the electrical path through the part. A continuity check can usually be made without removing the part from the vehicle. Simply disconnect the connectors and connect a continuity tester to the terminals or connections.

18. LIGHTS/SWITCHES

BULBS REMOVAL

HEADLIGHT

Disconnect the headlight wire connector.
Remove the rubber boot from the headlight case.

Headlight Connector

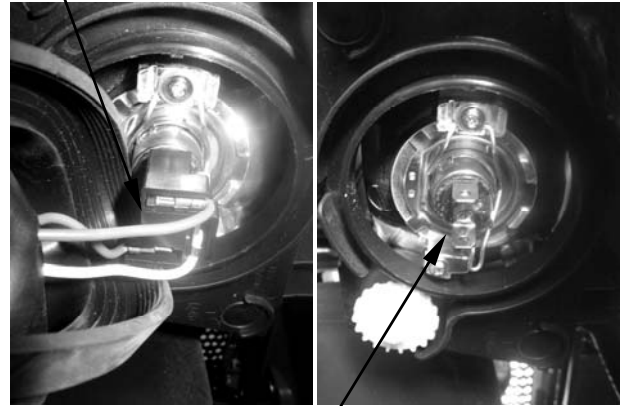

Rubber Boot

Relax the lock clip to remove the bulb and replace with a new one.

Install the bulb, aligning the bulb socket groove with the bulb tab and set the lock clip.

Connect headlight wire connector.
Install the rubber boot.

Install the front fender in the reverse order of removal.

Lock Clip

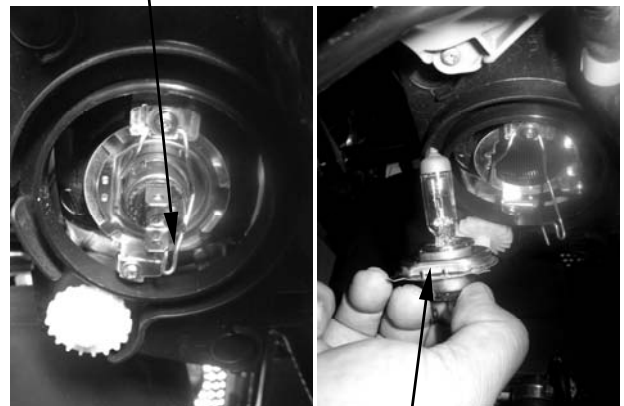

Bulb

POSITION LIGHT

Remove three screws then to separate this position light(one unit of LED type)

Install position light in the reverse order of removal



Position light

18. LIGHTS / SWITCHES

TAIL/BRAKE LIGHT

Remove screws then to separate this tail/brake light(one unit of LED type)

Install tail/brake light in the reverse order of removal.

Tail/brake light

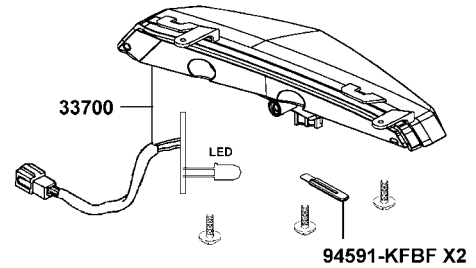

TURN SIGNAL LIGHT (ON ROAD)

FRONT/REAR

Remove screws then to separate this turn signal light(one unit of LED type)

Install turn signal light in the reverse order of removal.

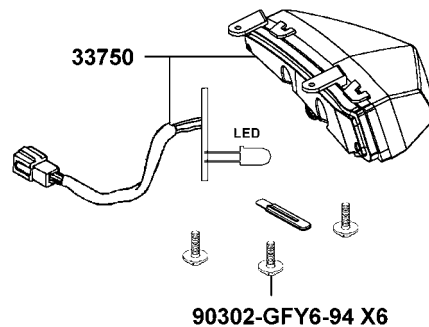
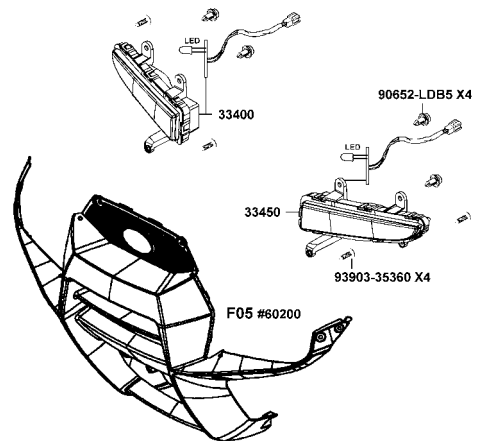

18. LIGHTS/SWITCHES

REAR

Remove screws then to separate this rear light(one unit of LED type)

Install rear light in the reverse order of removal.

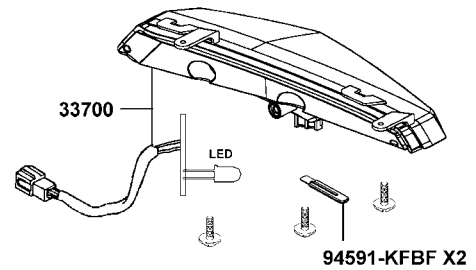

LICENCE LIGHT BULB (ON ROAD)

Remove the two screws and licence light cover.

Remove the bulb.

Install the bulb in the reverse order of removal

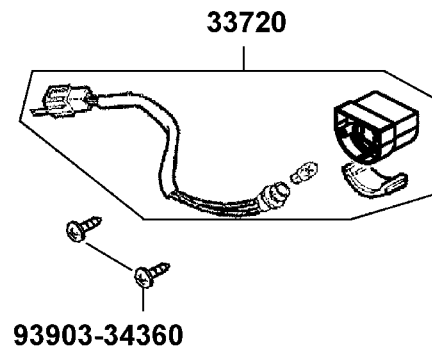

HORN (ON ROAD)

REMOVAL

Disconnect the horn wire leads.
Remove the bolt and remove horn.

INSTALLATION

The installation sequence is the reverse of removal.

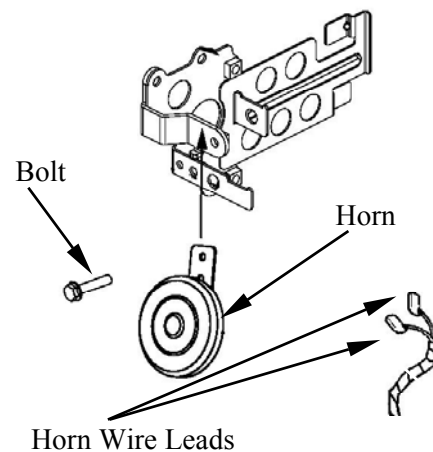

18. LIGHTS / SWITCHES

IGNITION SWITCH

INSPECTION

Disconnect the ignition switch connectors. (Refer to the “**FRAME COVER**” section in the chapter 2.)

Check for continuity between the switch side connector terminals in each switch position.

Continuity should exist between the color coded wires as right:

	IG	E	BAT1	BAT2	PO
OFF	○	○			
ON			○	○	
PO			○	○	○
COLOR	B/W	G	R	B	BR

REPLACEMENT

Release the switch wire from the wire clips on the steering shaft holder frame pipe.

Remove the meter cover (refer to the “**FRAME COVER**” section in the chapter 2).

Remove the ignition switch from the cover while pushing in the two stoppers.

Install a new ignition switch by aligning the locating tab with the groove in the cover.

Install the removed parts in the reverse order of removal.

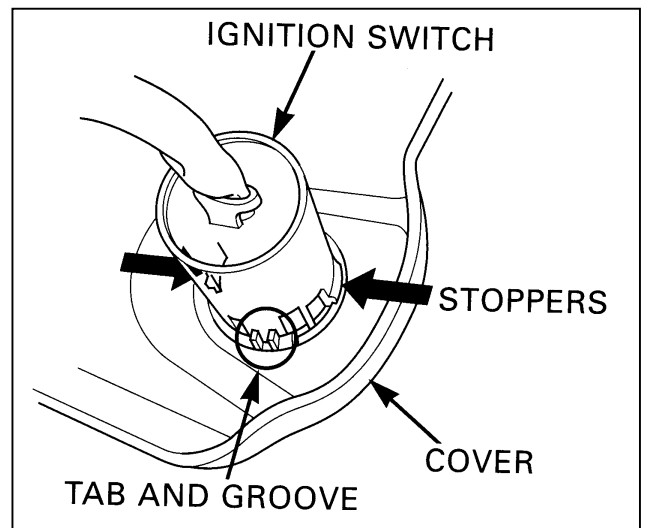

HANDLEBAR SWITCH

INSPECTION

Remove front center cover (refer to the “**FRAME COVER**” section in the chapter 2).

Disconnect the connectors.

Check for continuity between the switch side connector terminals in each switch position.

Continuity should exist between the color coded wires as next page:

18. LIGHTS/SWITCHES

(ON ROAD)

HORN SW

	HO	BAT
FREE		
PUSH	○	○
COLOR	LG	B

WINKER SW

	R	L	WR
L		○	○
R	○		○
COLOR	SB	O	GR

START SW

	ST	C
FREE		
PUSH	○	○
COLOR	Y/R	Y/B

LIGHT SW

	PO	LO	HI
☰	○		
☷	○	○	
☷	○		○
COLOR	BR/B	W	L

HAZARD SW

	BAT	HA
△	○	○
●		
COLOR	R/W	Y/B

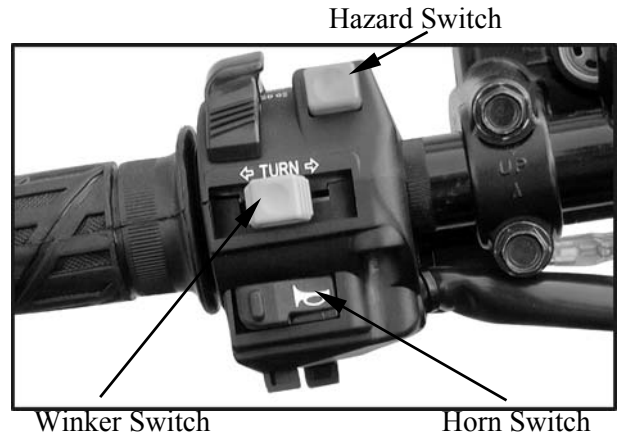

Winker Switch

Horn Switch

Light Switch

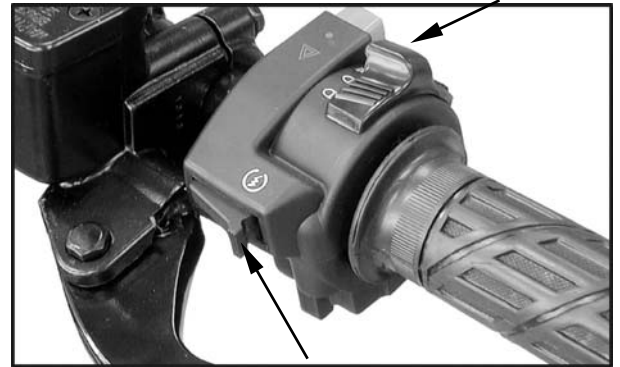

Start Switch

2WD/4WD SW

	2WD	4WD	4WD LOCK
4WD LOCK	○	○	○
4WD	○	○	
2WD	○		
COLOR	G	W/L	W/O



2WD/4WD Select and 4WD lock Button

18. LIGHTS / SWITCHES

(OFF ROAD)

ENGINE STOP SW

	E	IG
COLOR	BR/L	B/W

START SW

	ST	C
FREE		
PUSH		
COLOR	Y/R	B/W

DIMMER SW

	HL	LO	HI
COLOR	BR/B	W	L

PASSING SW

	ST	C
FREE		
PUSH		
COLOR	BR/L	L

Dimmer Switch



Start Switch

Passing Switch

Engine Stop Switch

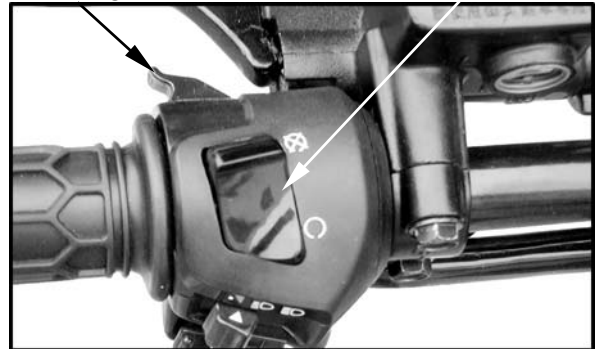

2WD/4WD SW

	2WD	4WD	4WD LOCK
4WD LOCK			
4WD			
2WD			
COLOR	G	W/L	W/O



2WD/4WD Select and 4WD lock Button

18. LIGHTS/SWITCHES

GEAR INDICATOR LIGHT SWITCHES

INSPECTION

Disconnect the gear indicator light switch wire connector.

Check for continuity between the switch side connector terminal and engine ground.

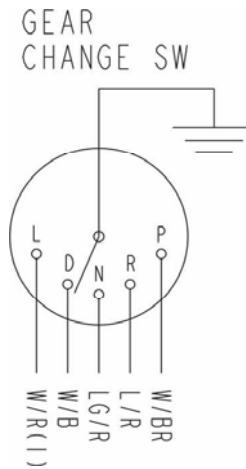

REPLACEMENT

Disconnect the gear indicator light switch connector.

Remove the bolt, then remove the gear indicator light switch and washer.



Gear Indicator Light Switch

Gear Indicator Light Switch Connector

Install the washer and a new switch with a new O-ring (apply engine oil to O-ring).

***** Make sure that the lever on the gear indicator light switch correctly engages with the locating slot on the shift shaft.

Shift the drive select lever to check if the gear indicator light is correct.

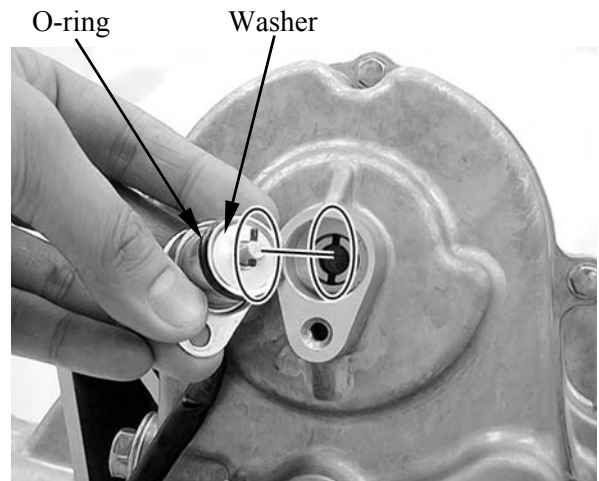

18. LIGHTS / SWITCHES

SPEED SENSOR

Disconnect the connector.

Remove the bolt then remove the speed sensor.

If the speedometer, odometer or trip meter does not function properly. Inspect the connection of speed sensor connector.

If the connection is all right, replace the speedometer with a new one.

If the speedometer, odometer or trip meter still does not function properly, replace the speed sensor.

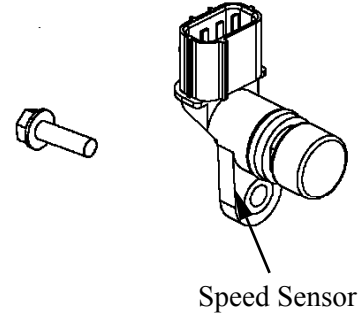

18. LIGHTS/SWITCHES

FUEL PUMP UNIT

REMOVAL

Disconnect the connector and fuel band from the fuel pump.
 Remove the six screws onto the fuel pump.
 Remove the fuel pump and O-ring.

INSPECTION

Put the side stand up and the engine stop switch is at "RUN"

Disconnect the fuel pump/fuel unit connector.

Connect the multimeter (+) probe to the Gray terminal and the multi-meter (-) probe to the Gray terminal.

Turn the ignition switch to "ON" and measure the voltage between the terminals. It should be shown the current battery voltage for a few seconds.

If there is still battery voltage, replace the fuel pump.

If there is not any battery voltage, inspect the following:

- Fuse
- Fuel pump relay
- ECU

Measure the resistance between the both Gray terminals of the fuel pump side connector.

Standard (at 20°C/68°F): About 10.7 Ω

Fuel level sensor inspection

Measure the resistance between the Gray and Gray terminals of fuel pump side connector.

Standard (at 20°C/68°F):

Float at full position About 101 Ω

Float at empty position About 3 Ω

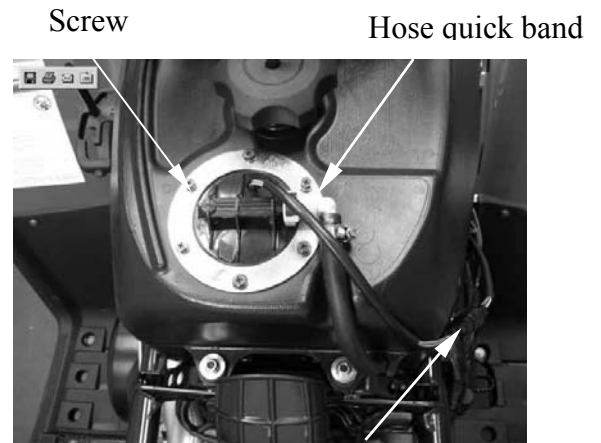

Fuel Pump Connector

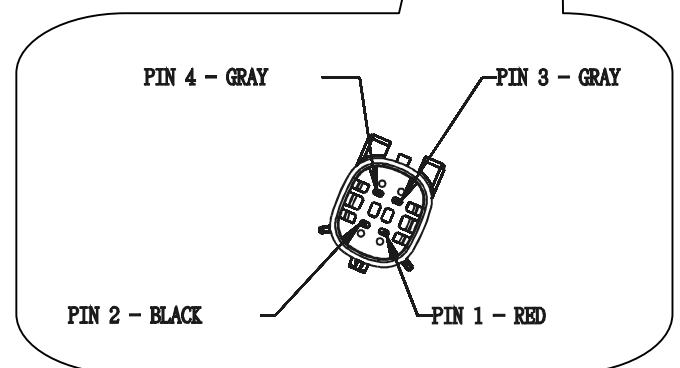
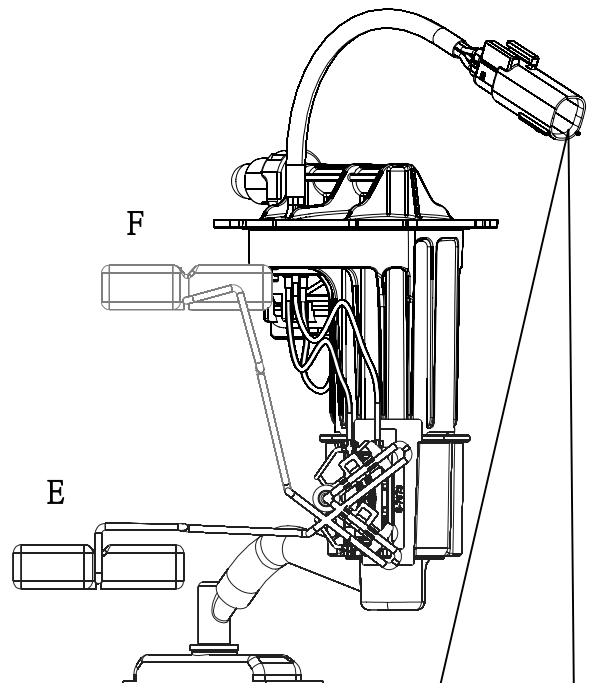

18. LIGHTS / SWITCHES

INSTALLATION

Replace a new O-ring on the fuel tank.
Don't damage the fuel pump wire and ensure the connector rearward carefully.

Torque: 0.35 kgf-m (3.5 N-m, 2.5 lbf-ft)

FUEL OUTPUT PRESSURE INSPECTION

Turn the key to the OFF position.
Use the fuel hose clamp.
Disconnect the fuel hose from the fuel injector.
Connect the fuel pressure gauge.
Turn the key to the ON position.
Check the fuel pressure.

Standard:3.0 Bar

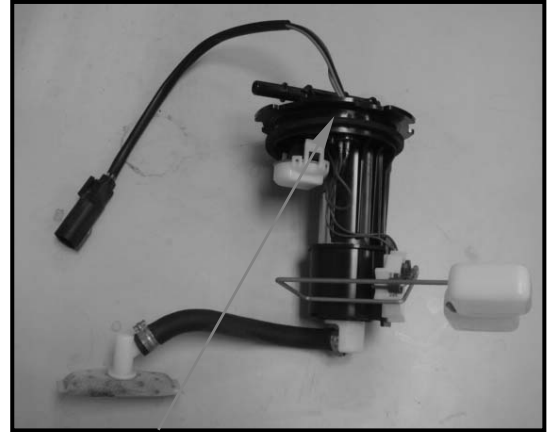

O-ring

*

If the fuel output pressure is less than 3.0 bar, may fail to start the engine or in trouble in case of riding.

19. STARTER SYSTEM

STARTER SYSTEM

19

STARTING SYSTEM LAYOUT -----	19- 1
SERVICE INFORMATION-----	19- 2
TROUBLESHOOTING-----	19- 2
STARTER MOTOR -----	19- 3
STARTER RELAY SWITCH/STARTER MAG -----	19- 4
STARTING COVER REMOVAL/INSPECTION/ INSTALLATION -----	19- 6
STARTER PULLEY REMOVAL/INSPECTION/ INSTALLATION -----	19- 8
STARTER CLUTCH REMOVAL/INSPECTION/ INSTALLATION -----	19-12

19. STARTER SYSTEM

STARTING SYSTEM LAYOUT

ON ROAD

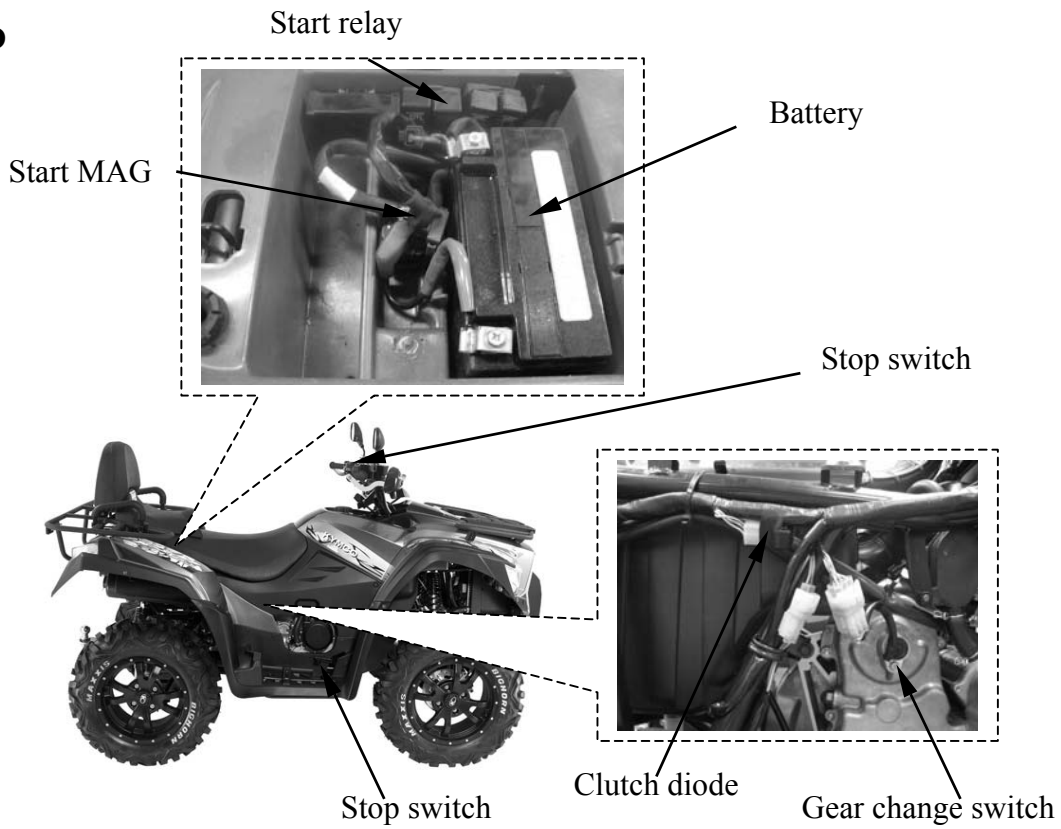

OFF ROAD

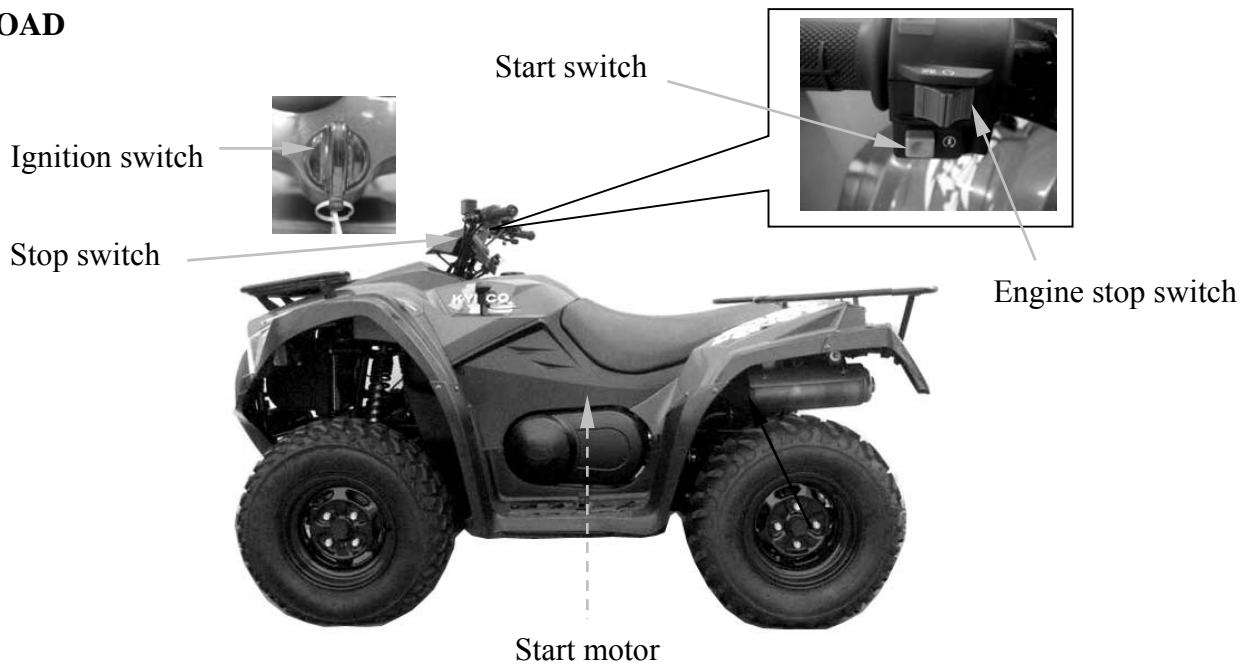

19. STARTER SYSTEM

SERVICE INFORMATION

GENERAL

- Always turn the ignition switch to “OFF” before servicing the starter motor. The motor could suddenly start, causing serious injury.
- The starter motor can be serviced with the engine in the frame.
- When checking the starter system, always follow the steps in the troubleshooting flow chart (page 19-2).
- A weak battery may be unable to turn the starter motor quickly enough, or supply adequate ignition current.
- If the current is kept flowing through the starter motor to turn it while the engine is not cranking over, the starter motor may be damaged.
- See section 20 for following components:
 - ™ Ignition switch
 - ™ Starter switch
 - ™ Brake light switch

SPECIAL TOOL

Flywheel puller A120E00060

TORQUE

Starter pulley nut 5.5 kgf-m (55 N-m, 40 lbf-ft)

TROUBLESHOOTING

- Check for the following before troubleshooting:
 - Blown main fuse (30A) and sub fuse (15 A)
 - Loose battery and starter motor cable
 - Discharged battery
- The starter motor can turn with the following conditions:
 - Ignition switch ON
 - Engine stop switch in RUN (OFF ROAD)
 - Rear brake lever fully squeezed
 - Starter switch pushed

19. STARTER SYSTEM

STARTER MOTOR

INSPECTION

Disconnect the starter motor cable from the starter MAG.
 Turn the ignition switch to “ON”.
 Connect the starter motor cable directly to the battery positive terminal.
 If the starter motor does not turn, the starter motor is faulty.

Starter Motor Cable

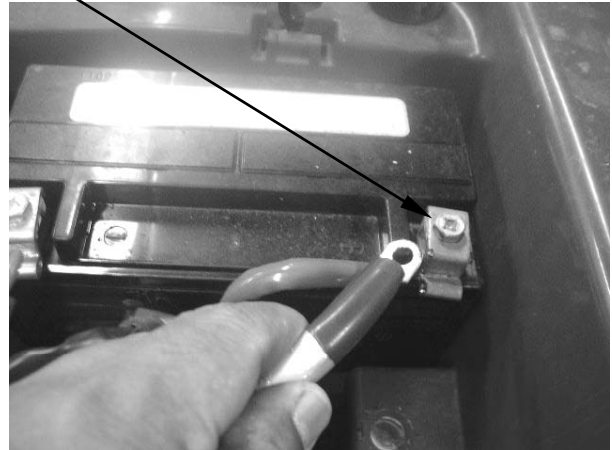

REMOVAL

Remove the carburetor (refer to the “**CARBURETOR REMOVAL/CHOKE INSPECTION/INSTALLATION**” section in the chapter 5).

Turn the ignition switch turned to “OFF”

Remove the two mounting bolts and starter motor.

Release the rubber cap and remove the terminal nut to disconnect the starter motor cable from the starter motor.

Rubber Cap

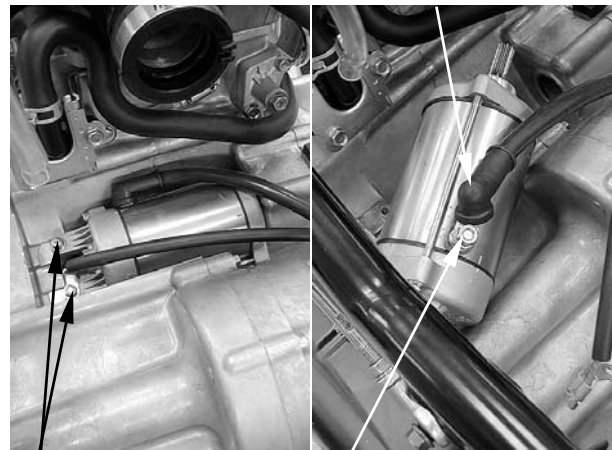

Bolts

Nut

INSTALLATION

Coat a new O-ring with engine oil and install it into the starter motor groove.

Connect the starter motor cable to motor terminal with the terminal nut and tighten it.

Install the starter motor into the crankcase.

Install the two mounting bolts and tighten them securely.

O-ring



19. STARTER SYSTEM

STARTER RELAY SWITCH/STARTER MAG

INSPECTION

Turn the ignition switch to “ON”.

Squeeze the brake lever or pedal fully.

The coil is normal if the starter relay switch clicks.

Squeeze and hold the brake lever or pedal fully then push the starter switch.

The coil is normal if the starter MAG switch clicks.

If you do not hear the switch click. Inspect the relay switch and starter MAG using the procedure below.

GROUND LINE INSPECTION

Disconnect the starter relay switch connector. Check for continuity between the Green wire terminal and ground.

There should be continuity.

VOLTAGE INSPECTION

Connect the starter MAG connector. Turn the ignition switch ON.

Measure the starter MAG Yellow/Red wire terminal and ground.

If the battery voltage appears only when the rear brake lever is squeezed fully (or the gear change switch in neutral) and starter switch is pushed, the circuit is normal.

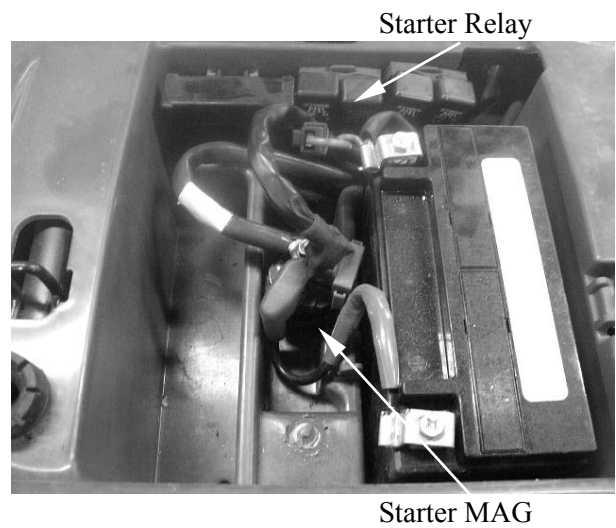

19. STARTER SYSTEM

CONTINUTY INSPECTION

Disconnect the starter MAG switch connector and cables.

Connect a fully charged 12 V battery positive wire to the relay switch Yellow/Red wire terminal and negative wire to the Yellow/Green wire terminal.

There should be continuity between the cable terminals while the battery is connected, and no continuity when the battery is disconnected.



19. STARTER SYSTEM

STARTING COVER REMOVAL/INSPECTION/ INSTALLATION

* The starter without function

REMOVAL

Remove the six bolts, then remove the starting cover assembly.

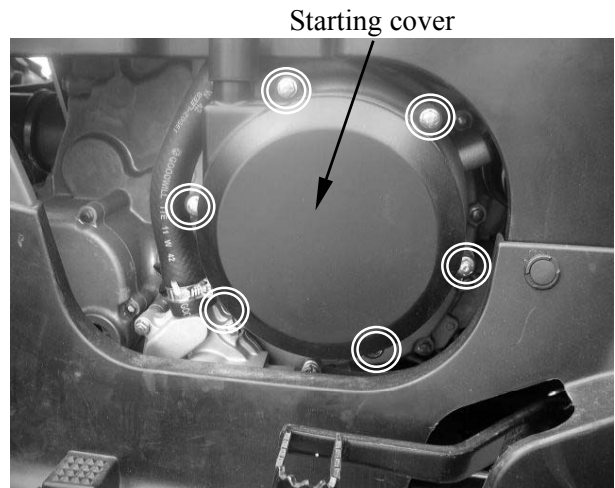

Remove the two dowel pins.

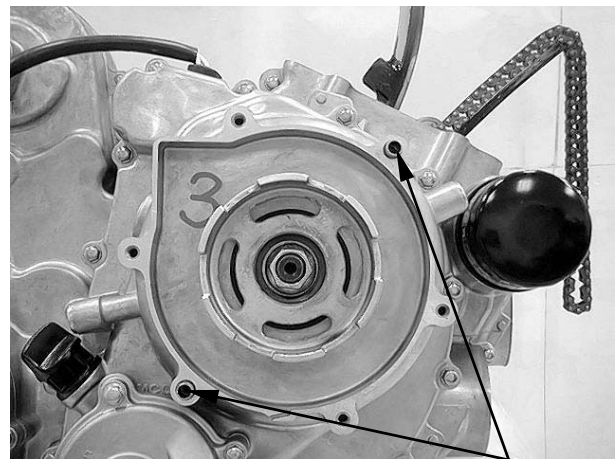

Dowel Pins

INSTALLATION

Install the dowel pins.

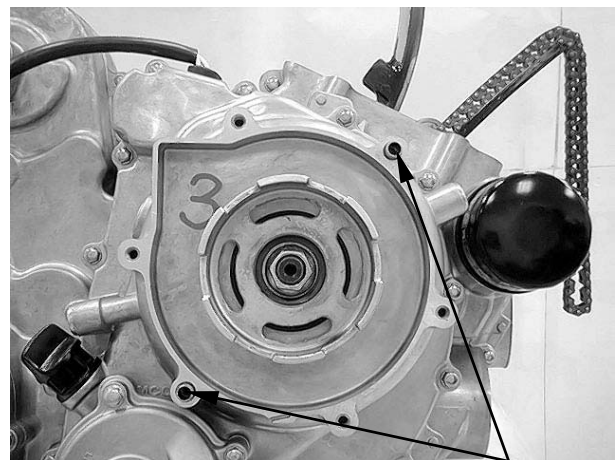

Dowel Pins

19. STARTER SYSTEM

Install the starting cover assembly.
Install and tighten the six bolts diagonally.

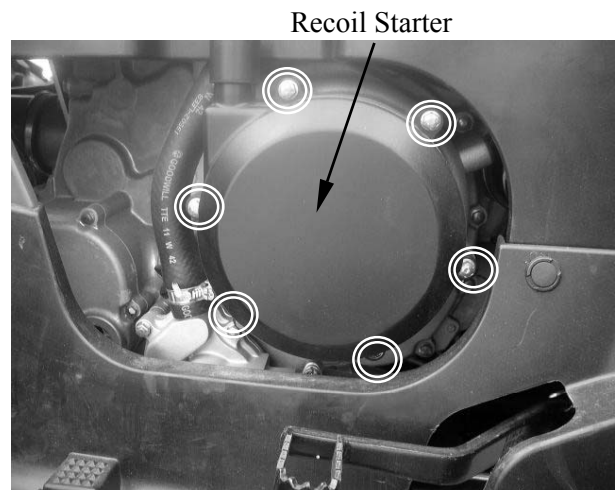

19. STARTER SYSTEM

STARTER PULLEY REMOVAL/INSPECTION/ INSTALLATION

REMOVAL

Remove the recoil starter assembly (refer to the “**RECOIL STARTER REMOVAL/INSPECTION/INSTALLATION**” section in this chapter).

Remove the starter pulley nut by using a suitable bar.

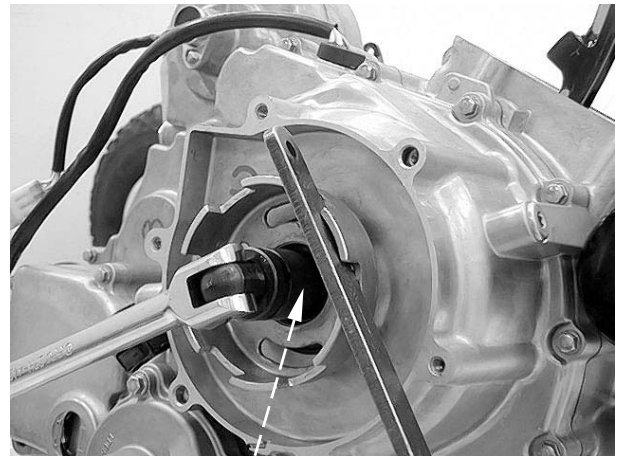

Nut/Washer

INSPECTION

Inspect the starter pulley for cracks or pitting.
Inspect the O-ring for wear or damage.



O-ring

Inspect the oil stop ring for crack or damage.



Oil Stop Ring

19. STARTER SYSTEM

INSTALLATION

Install the starter pulley and washer.
Install and tighten the nut to the specified torque by using suitable bar.

Torque: 5.5 kgf-m (55 N-m, 40 lbf-ft)

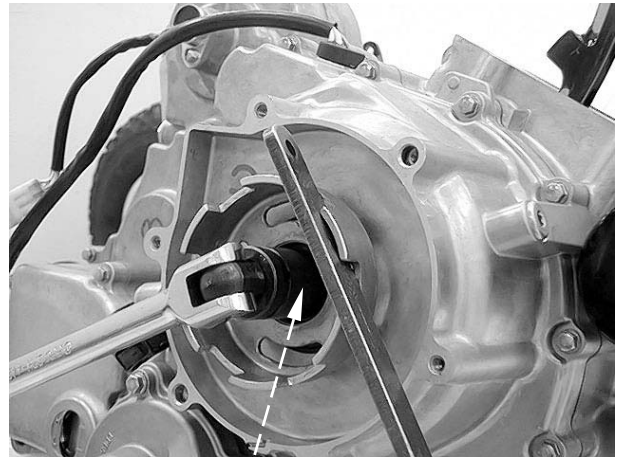

Nut/Washer

19. STARTER SYSTEM

STARTER CLUTCH REMOVAL/INSPECTION/ INSTALLATION

REMOVAL

Remove the right crankcase cover (refer to the “**ALTERNATOR STATOR REMOVAL/INSPECTION/INSTALLATION**” section in the chapter 17).

Remove the flywheel/driven gear by using the special tool.

Special tool:

Flywheel puller A120E00060

Remove the woodruff key.

Remove the reduction gear.

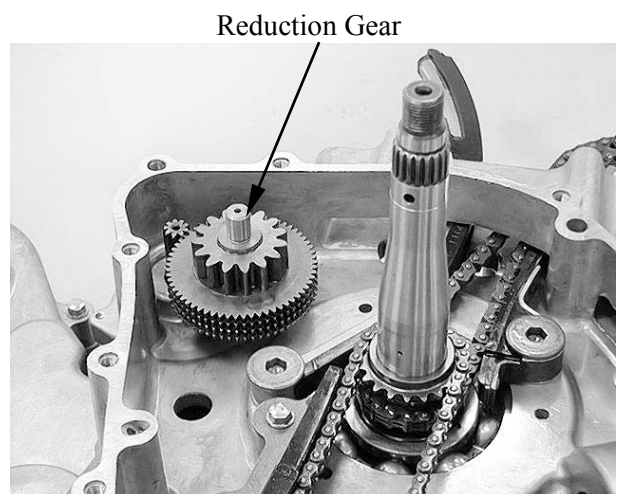
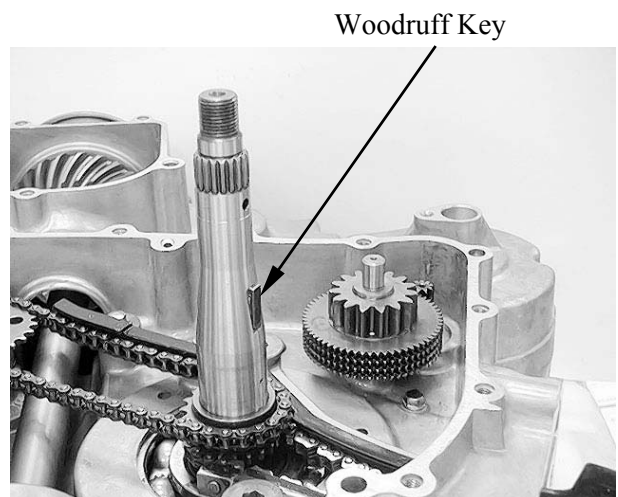
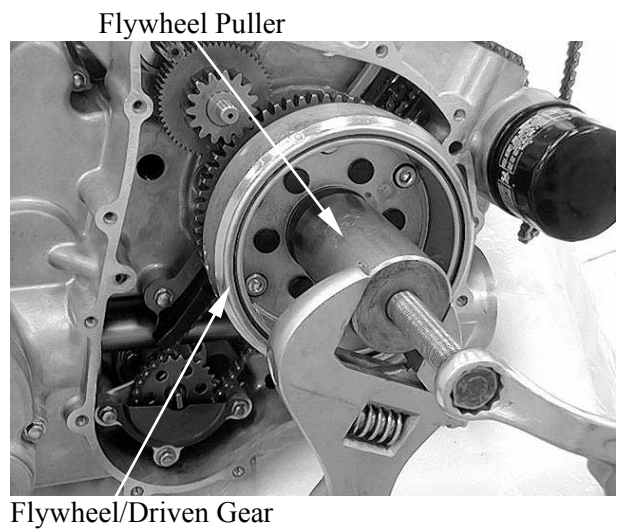

19. STARTER SYSTEM

INSPECTION

Check the operation of the sprag clutch by turning the driven gear. You should be able to turn the driven gear clockwise smoothly, but the gear should not turn counterclockwise.

Remove the starter driven gear by turning the driven gear.



Check the starter driven gear teeth for wear or damage.

Measure the starter driven gear boss O.D..

Service limit: 57.7 mm (2.272 in)

Measure the starter driven gear bushing I.D..

Service limit: 27.1 mm (1.084 in)

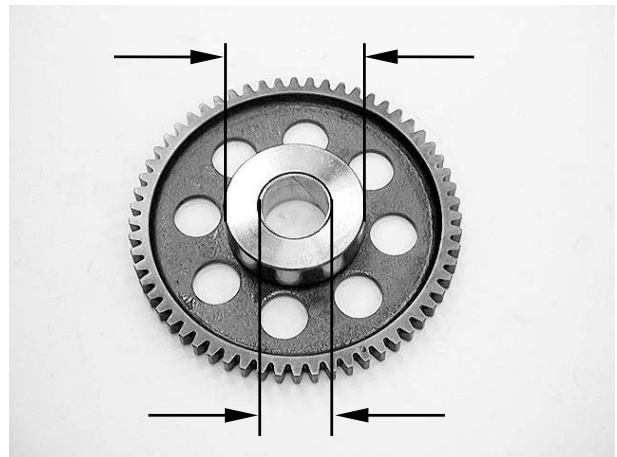

Check the starter reduction gear teeth and shaft for wear or damage.



19. STARTER SYSTEM

INSTALLATION

Apply oil to the starter reduction gear.
Install the starter reduction gear to the right crankcase.

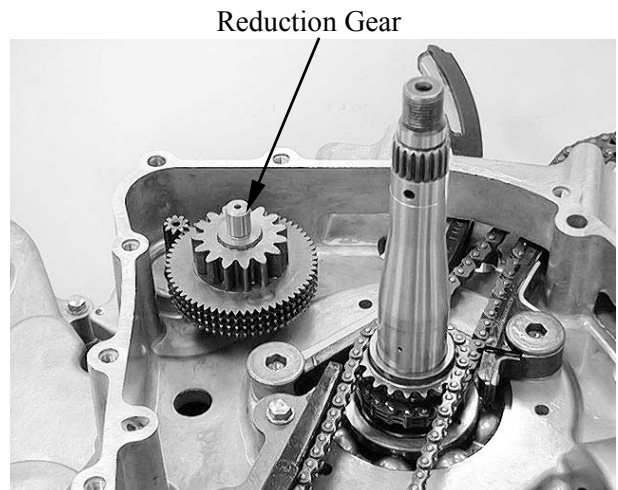

Install the woodruff key in the crankshaft key groove.

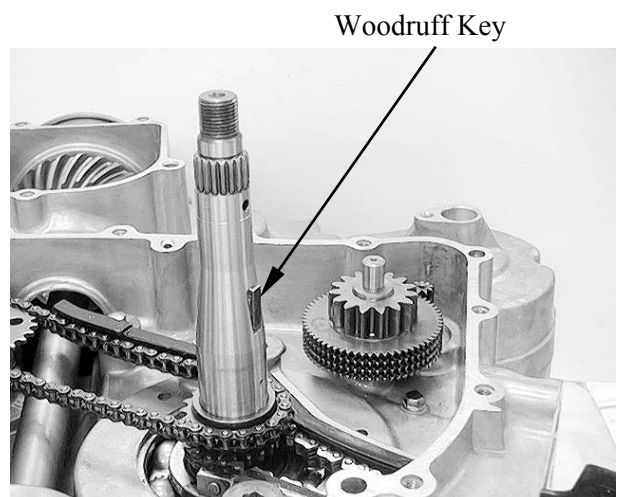

Apply molybdenum oil solution to the starter driven gear bushing.
Install the starter driven gear by turning the driven gear clockwise.

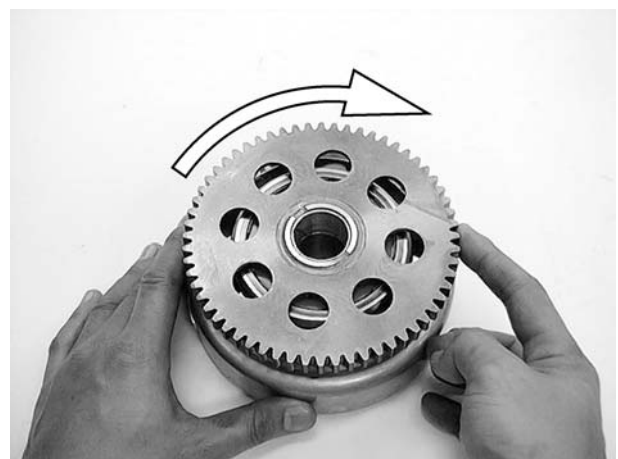

19. STARTER SYSTEM

Clean any oil from the tapered portion of the flywheel I.D.

Install the flywheel/driven gear onto the crankshaft, aligning the key way with woodruff key.

