

**By KWANG YANG Motor Co., Ltd.
1st Edition, August 2021
All rights reserved. Any reproduction or
unauthorized use without the written
permission of KWANG YANG Motor Co., Ltd.
is expressly prohibited.
T300-AKC8-A1**

PREFACE

This Service Manual describes the technical features and servicing procedures for the **People S 300**

Section 1 contains the precautions for all operations stated in this manual. Read them carefully before any operation is started.

Section 2 is the removal/installation procedures for the frame covers which are subject to removal/installation frequency during maintenance and servicing operations.

Section 3 describes the inspection/adjustment procedures, safety rules and service information for each part, starting from periodic maintenance.

Sections 5 to 12 give instructions for disassembly, assembly and adjustment of engine parts. Section 13 is the AFI system. Section 14 to 15 is the removal/ installation of chassis. Section 16 to 19 states the testing and measuring methods of electrical equipment. Section 20 is the ABS and Section 21 is EEC system.

Most sections start with an assembly or system illustration and troubleshooting for the section. The subsequent pages give detailed procedures for the section.

The information and contents included in this manual may be different from the motorcycle in case specifications are changed.

TABLE OF CONTENTS

ENGINE	GENERAL INFORMATION	1
	EXHAUST MUFFLER/FRAME COVERS	2
	INSPECTION/ADJUSTMENT	3
	LUBRICATION SYSTEM	4
	ENGINE REMOVAL/INSTALLATION	5
	CYLINDER HEAD/VALVES	6
	CYLINDER/PISTON	7
	DRIVE AND DRIVEN PULLEYS / V-BELT	8
	FINAL REDUCTION	9
	A.C. GENERATOR / STARTER CLUTCH	10
	CRANKCASE / CRANKSHAFT	11
	COOLING SYSTEM	12
	FUEL INJECTION SYSTEM	13
CHASSIS	STEERING HANDLEBAR / FRONT WHEEL / FRONT BRAKE / FRONT SHOCK ABSORBER / FRONT FORK	14
	REAR BRAKE / REAR FORK / REAR WHEEL / REAR SHOCK ABSORBER	15
ELECTRICAL	BATTERY/CHARGING SYSTEM	16
	IGNITION SYSTEM	17
	STARTING SYSTEM	18
	LIGHTS SWITCHES / FUEL PUMP	19
ABS	ANTI-LOCK BRAKE SYSTEM(ABS)	20
EEC	EEC SYSTEM	21

KWANG YANG MOTOR CO., LTD.
TECHNICAL EDUCATION DEPT.

1. GENERAL INFORMATION



GENERAL INFORMATION

SERIAL NUMBER	1-2
SPECIFICATIONS.....	1-3
SERVICE PRECAUTIONS.....	1-4
TORQUE VALUES	1-9
SPECIAL TOOLS	1-11
LUBRICATION POINTS FRAME	1-12
CABLE & HARNESS ROUTING	1-13
TROUBLESHOOTING	1-24

1. GENERAL INFORMATION

SERIAL NUMBER



Location of Frame Serial Number

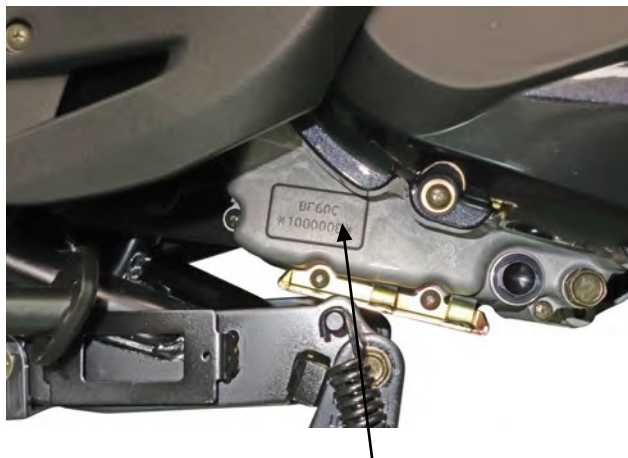

Location of Engine Serial Number

1. GENERAL INFORMATION

SPECIFICATIONS

Name		People S 300 E5
Model No.		BF60DA
Overall length		2130 mm
Overall width		750 mm
Overall height		1240 mm
Wheel base		1450 mm
Engine type		4 stroke O.H.C.
Displacement		298.9 cc
Fuel Used		92# nonleaded gasoline
Curb weight (kg)	Front wheel	68
	Rear wheel	110
	Total	178
Max. weight (kg)	Front wheel	101
	Rear wheel	162
	Total	263
Ground clearance (mm)		130
Braking distance (m)		7.9m / 40 km/hr
Min. turning radius (mm) R/L		2250/2170
Engine part		
Starting system		Starting motor
Type		Gasoline 4-cycle
Cylinder arrangement		Single cylinder
Combustion chamber type		Semi-sphere
Valve arrangement		O.H.C.-4V
Bore x stroke (mm)		$\phi 72.7 * 72$
Compression ratio		10.8:1
Compression pressure (kg/cm ² -rpm)		16-570 rpm
Max. output (ps/rpm)		27.3 / 8000
Max. torque (kg-m/rpm)		2.7 / 6500
Intake Timing	Open	-9.5° BTDC
	Close	37.5° BTDC
Exhaust Timing	Open	39.5° BTDC
	Close	10.5° BTDC
Valve clearance	Intake	0.10
	Exhaust	0.10
Idle speed (rpm)		1600±100 rpm
Cooling Type		Liquid cooling
Lubrication type		Forced pressure & wet sump
Oil pump type		Inner/outer rotor

Oil filter type		Full-flow filtration
Oil capacity		1.5 liter
Exchanging capacity		1.3 liter
Fi injection system		
Air cleaner type & No		Paper element, wet
Fuel capacity		9 liters
Brand		Keihin
Throttle Body		Butterfly type
Venturi diameter (mm)		34
Fuel pump pressure		3.0 bar
Electrical system		
Ignition type		ECU
Ignition timing		ECU control
Spark plug		CR7E (NGK)
Spark plug gap		0.7 - 0.8mm
Battery Capacity		12V10AH
Transmission system		
Clutch type		Dry multi-disc
Transmission type		CVT
Operation type		Auto centrifugal
Reduction gear type		Two-stage reduction
Reduction ratio	Primary	2.75~0.79
	Final	8.07
Moving device		
Tire type		Tubeless
Tire spec.	Front wheel	110/70-16
	Rear wheel	140/70-16
Tire pressure (kg/cm ²)	Front wheel	1.75
	Rear wheel	2.25 (with passenger)
Wheel material		Aluminium
Turning angle	Left	45°±5
	Right	45°±5
Brake type	Front	ABS
	Rear	ABS
Damping Device		
Suspension type	Front	Telescope
	Rear	Swing arm
Shock absorber stroke	Front	110 mm
	Rear	100 mm

1. GENERAL INFORMATION

SERVICE PRECAUTIONS

- Make sure to install new gaskets, O-rings, circlips, cotter pins, etc. when reassembling.

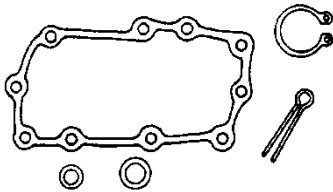

- When tightening bolts or nuts, begin with larger-diameter to smaller ones at several times, and tighten to the specified torque diagonally.

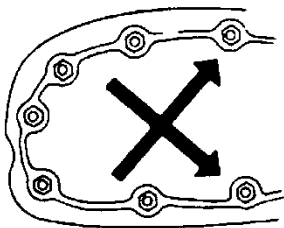

- Use genuine parts and lubricants.

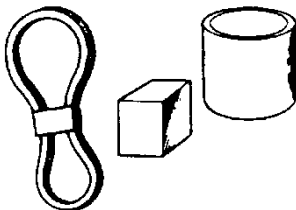

- When servicing the motorcycle, be sure to use special tools for removal and installation.



- After disassembly, clean removed parts. Lubricate sliding surfaces with engine oil before reassembly.

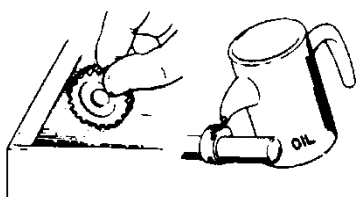

- Apply or add designated greases and lubricants to the specified lubrication points.

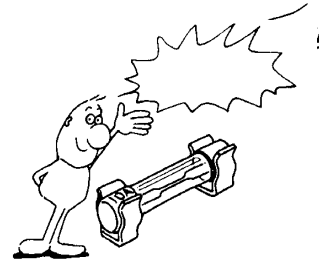

- When two persons work together, pay attention to the mutual working safety.

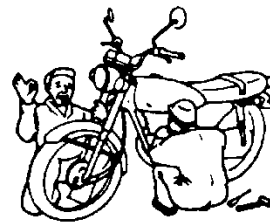

- Disconnect the battery negative (-) terminal before operation.
- When using a spanner or other tools, make sure not to damage the motorcycle surface.

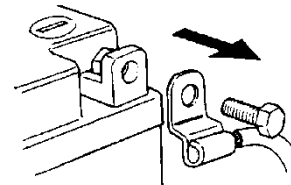

- After operation, check all connecting points, fasteners, and lines for proper connection and installation.
- When connecting the battery, the positive (+) terminal must be connected first.
- After connection, apply grease to the battery terminals.
- Terminal caps shall be installed securely.

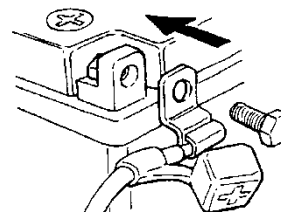

- If the fuse is burned out, find the cause and repair it. Replace it with a new one according to the specified capacity.

1. GENERAL INFORMATION

- After operation, terminal caps shall be installed securely.

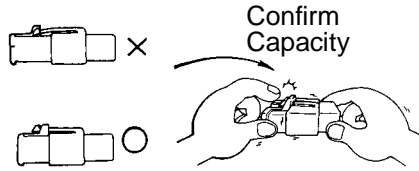

- When taking out the connector, the lock on the connector shall be released before operation.

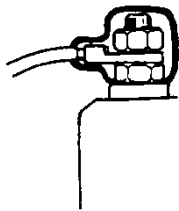

- Hold the connector body when connecting or disconnecting it.
- Do not pull the connector wire.

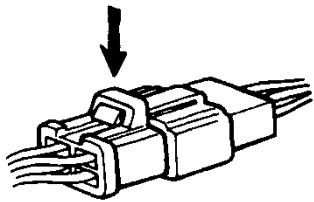

- Check if any connector terminal is bending, protruding or loose.

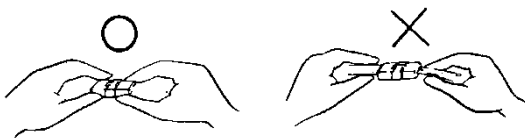

- The connector shall be inserted completely.
- If the double connector has a lock, lock it at the correct position.
- Check if there is any loose wire.

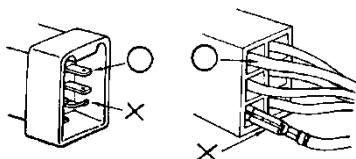

- Before connecting a terminal, check for damaged terminal cover or loose negative terminal.

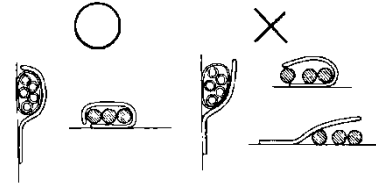

- Check the double connector cover for proper coverage and installation.

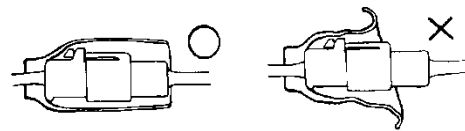

- Insert the terminal completely.
- Check the terminal cover for proper coverage.
- Do not make the terminal cover opening face up.

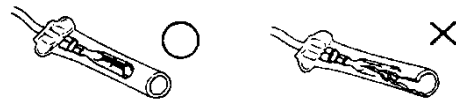

- Secure wire harnesses to the frame with their respective wire bands at the designated locations. Tighten the bands so that only the insulated surfaces contact the wire harnesses.

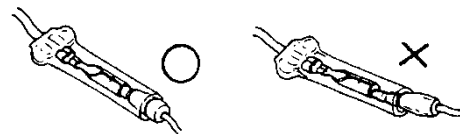

- After clamping, check each wire to make sure it is secure.

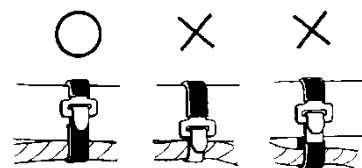

1. GENERAL INFORMATION

- Do not squeeze wires against the weld or its clamp.

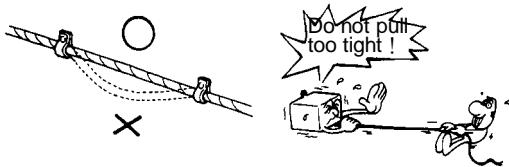

- After clamping, check each harness to make sure that it is not interfering with any moving or sliding parts.



- When fixing the wire harnesses, do not make it contact the parts that will generate high heat.

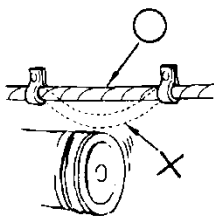

- Route wire harnesses to avoid sharp edges or corners. Avoid the projected ends of bolts and screws.
- Route wire harnesses passing through the side of bolts and screws. Avoid the projected ends of bolts and screws.

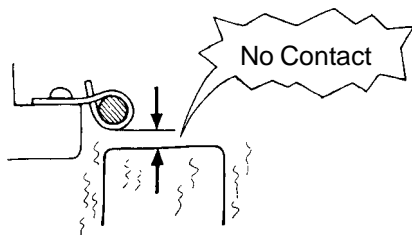

- Route harnesses so they are neither pulled tight nor have excessive slack.

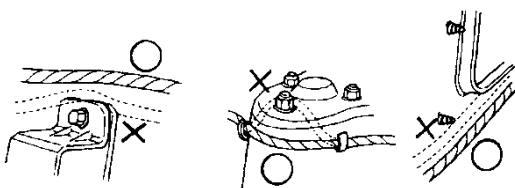

- Protect wires and harnesses with electrical tape or tube if they contact a sharp edge or corner.

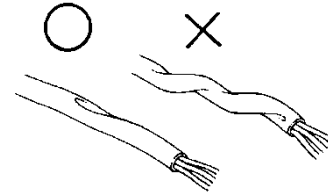

- When rubber protector cover is used to protect the wire harnesses, it shall be installed securely.

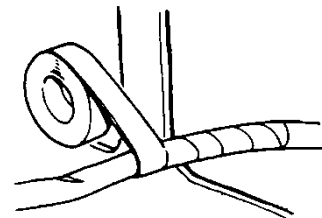

- Do not break the sheath of wire.
- If a wire or harness is with a broken sheath, repair by wrapping it with protective tape or replace it.

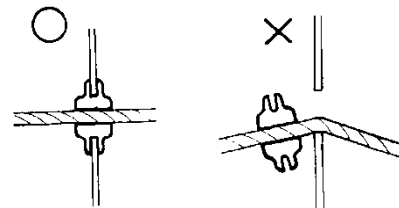

- When installing other parts, do not press or squeeze the wires.

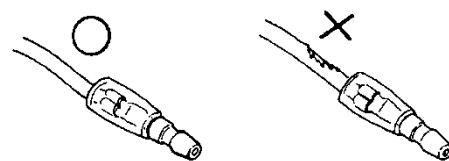

- After routing, check that the wire harnesses are not twisted or kinked.

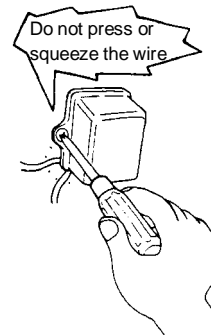

1. GENERAL INFORMATION

- Wire harnesses routed along with handlebar should not be pulled tight, have excessive slack or interfere with adjacent or surrounding parts in all steering positions.

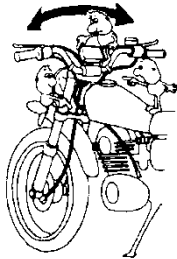

- When a testing device is used, make sure to understand the operating methods thoroughly and operate according to the operating instructions.

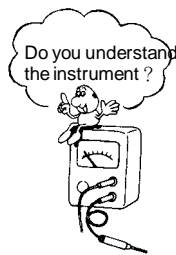

- Be careful not to drop any parts.

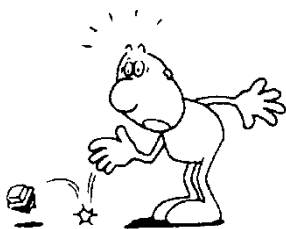

- When rust is found on a terminal, remove the rust with sand paper or equivalent before connecting.



1. GENERAL INFORMATION

■ Symbols:

The following symbols represent the servicing methods and cautions included in this service manual.



: Apply engine oil to the specified points. (Use designated engine oil for lubrication.)

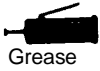

: Apply grease for lubrication.



: Transmission Gear Oil (90#)



: Use special tool.



: Caution



: Warning

1. GENERAL INFORMATION

TORQUE VALUES

STANDARD TORQUE VALUES

Item	Torque (kgf-m)	Item	Torque (kgf-m)
5mm bolt, nut	0.45~0.6	5mm screw	0.45~0.6
6mm bolt, nut	0.8~1.2	6mm screw, SH bolt	0.7~1.1
8mm bolt, nut	1.8~2.5	6mm flange bolt, nut	1.0~1.4
10mm bolt, nut	3.0~4.0	8mm flange bolt, nut	2.4~3.0
12mm bolt, nut	5.0~6.0	10mm flange bolt, nut	3.0~4.5

ENGINE

Item	Qty	Thread size (mm)	Torque (kgf-m)	Remarks
Cylinder head stud bolt:				
1.Stud bolt (Inlet pipe side)	2	6	0.7~1.1	Double end bolt
2.Stud bolt (EX pipe side)	2	8	0.7~1.1	Double end bolt
Cylinder head stud nut	4	10	3.4~3.8	
Right crankcase cover bolt	15	6	1.0~1.4	
Left crankcase cover bolt	15	6	1.0~1.4	
Bolt B stud 10*180	4	10	1.0~1.4	Apply oil to thread
Valve adjusting lock nut	4	5	0.7~1.1	Apply oil to thread
Cam sprocket bolt	2	6	1.0~1.4	
Transmission oil check/drain bolt	2	8	0.8~1.2	
Engine oil drain bolt	1	12	2.0~3.0	
Clutch outer nut	1	12	5.0~6.0	
Starter motor mounting bolt	2	6	1.0~1.4	
Mission case bolt	6	8	1.8~2.2	
Drive face nut	1	14	9.0~10.0	Apply oil to thread
Drive plate comp	1	28	5.0~6.0	
Cam chain tensioner bolt	2	6	1.0~1.4	
Cam chain tensioner pivot	1	8	0.8~1.2	
Oneway clutch bolt	3	8	1.8~2.2	Apply thread lock
ACG flywheel nut	1	14	5.5~6.5	
Spark plug	1	12	1.5~2.0	
Water pump impeller	1	7	1.0~1.4	Left thread

1. GENERAL INFORMATION

TORQUE VALUES FRAME

No.	ITEM	THREAD SIZE AND TYPE	TORQUE		PR値 Kgf-m	REMARK	THREAD DWG. NO.	重要度 Imp
			Kgf-m	N-m				
1	STEERING							
	HANDLE POST	M10x1.25	4.0~5.0	40~50	4.5	U NUT	90106-GEN5-9000	A
	BRIDGE BOLT	M8x1.25	2.4~3.0	24~30	2.7	—	95801-08040-08	A
	STEM LOCK	BC1	6.0~6.5	60~65	6.3	—	50306-1F96-0010	A
	RACE NUT(HEAD)	BC1	1.8~2.2	18~22	2.0	—	53220-LBA2-E000	B
2	WHEEL							
	FR.AXLE	M14x1.5	1.5~2.5	15~25	2.0	—	44301-LLJ3-E000	A
	RR.AXLE NUT	M16x1.5	13~15	130~150	14	U NUT	90305-KKAK-9000	A
3	SUSPENSION							
	FR FORK BOLT	M6x1.0	1.0~1.4	10~14	1.2	—	96600-06020-06	A
	RR. CUSH. UP	M10x1.25	3.5~4.5	35~45	4.0	—	95801-10035-00	A
	RR. CUSH. LWR	M10x1.25	3.5~4.5	35~45	4.0	—	95801-10035-00	A
4	BRAKE							
	FR CALIPER R	M10x1.25	3.0~4.0	30~40	3.5	—	90122-LEA7-E000	A
	RR CALIPER	M10x1.25	3.0~4.0	30~40	3.5	—	90122-LEA7-E000	A
	BRK OIL BOLT	M10x1.25	3.0~4.0	30~40	3.5	—	90145-MS9-6120-MI	A
	M/C HOLDER	M6x1.0	1.0~1.4	10~14	1.2	—	96001-06028-06	C
	M/C CAP SCREW	M4x0.7	0.12~0.2	1.2~2.0	0.16	—	96000-04012-1A	B
	C/P BLEEDER	M8x1.25	0.4~0.7	4.0~7.0	0.55	—	43352-5H68-0040	B
	DISK BOLT	M8x1.25	3.2~3.8	32~38	3.5	—	90105-KCR3-0010	A
5	ENG HANGER							
	FRAME SIDE	M14x1.5	6.0~7.0	60~70	6.5	U NUT	90305-LBD4-9000	A
	ENG SIDE	M10x1.25	4.5~5.5	45~55	5.0	U NUT	90304-GLW0-9020-MI	A
6	MUFFLER							
	EXH. PIPE	M8x1.25	1.8~2.2	18~22	2.0	—	90033-GFY6-9000	B
	MUFF. BRKT/RR FORK	M10x1.25	3.2~3.8	32~38	3.5	FLANGE BOLT	95801-10060-06	A
7	RR FORK/ENG CASE	M10x1.25	3.0~4.0	30~40	3.5	—	95801-10060-06	A
8	其他							
	SPDMT SENSOR CABLE	M6x1.0	1.0~1.4	10~14	1.2	—	96001-06012-06	C
	IGN COIL	M6x1.0	0.25~0.35	2.5~3.5	0.3	—	94050-06080	B
	O2 SENSOR	M12x1.25	2.0~3.0	20~30	2.5	—	—	B
	RR CARRIER	M10x1.5	3.0~4.0	30~40	3.5	—	90106-AFBI-E000	C
	FUEL PUMP	M5X0.8	0.25~0.4	2.5~4.0	0.33	—	95701-LDF2-8000	B

1. GENERAL INFORMATION

SPECIAL TOOLS

Tool Name	Tool No.	Performance	Photo
Flywheel Puller	A120E00003	A.C. generator flywheel removal	
Tappet Adjuster	A120E00012	Tappet adjustment	
Oil Seal & Bearing Installer	A120E00014	Oil seal & bearing installing	
Flywheel Holder	A120E00021	A.C. generator flywheel holding	
#41 Nut & Fitting	A120E00028	Clutch disassembly & assembly	
Thread Protector	A120E00029	Protecting the crankshaft's thread	
Valve Cotter Installer	A120E00051	Valve cotter installation	
Clutch Spring Compressor	A120E00053	Clutch disassembly & assembly	
Shaft Collar Puller	A120E00088	Bearing crankcase removal	
Shaft Collar Driver	A120E00091	Bearing crankcase removal	
Shaft Collar Installer	A120E00092	Bearing crankcase installation	
Bearing Puller	A120E00093	Bearing removal	
Lock Nut Socket Wrench	A120F00002	Steering stem removal or installation	
Integrated Linker	3620A-AGD7-900	Fuel injection system diagnosis	

1. GENERAL INFORMATION

LUBRICATION POINTS FRAME

The following is the lubrication points for the frame. Use grease for parts is listed.

Apply engine oil or grease to cables and movable parts not specified. It will avoid abnormal noise and damage the durability of the motorcycle.



Front wheel axle & nut



Side stand pivot
& Main stand pivot



Rear wheel axle & nut

1. GENERAL INFORMATION

CABLE & HARNESS ROUTING

Temperature Sensor



Winker Relay

Tilt Switch

Horn

Ignition Switch

ECU

ABS ECU

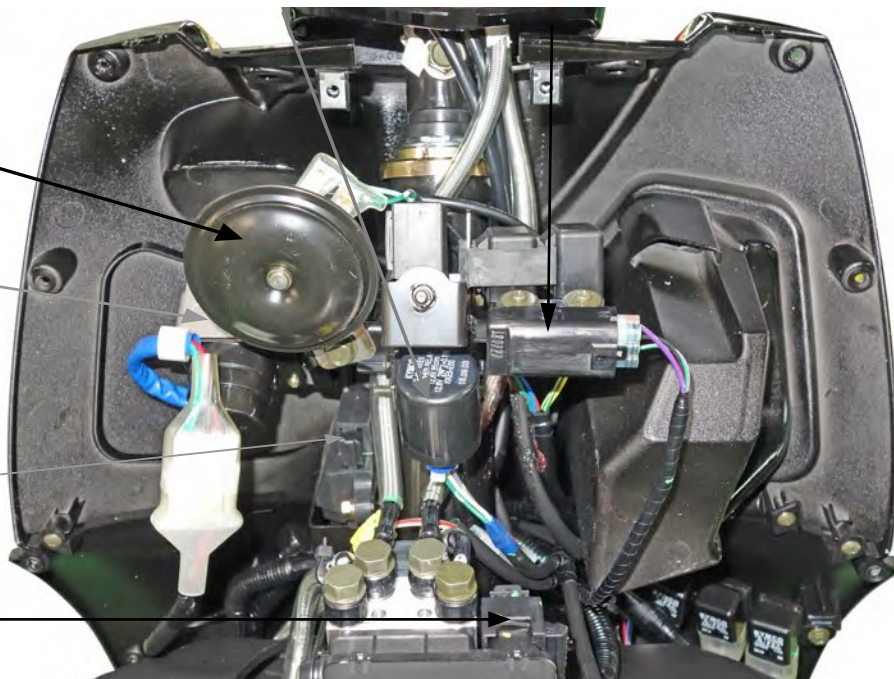

1. GENERAL INFORMATION

Oil Controller

Front Brake Hose

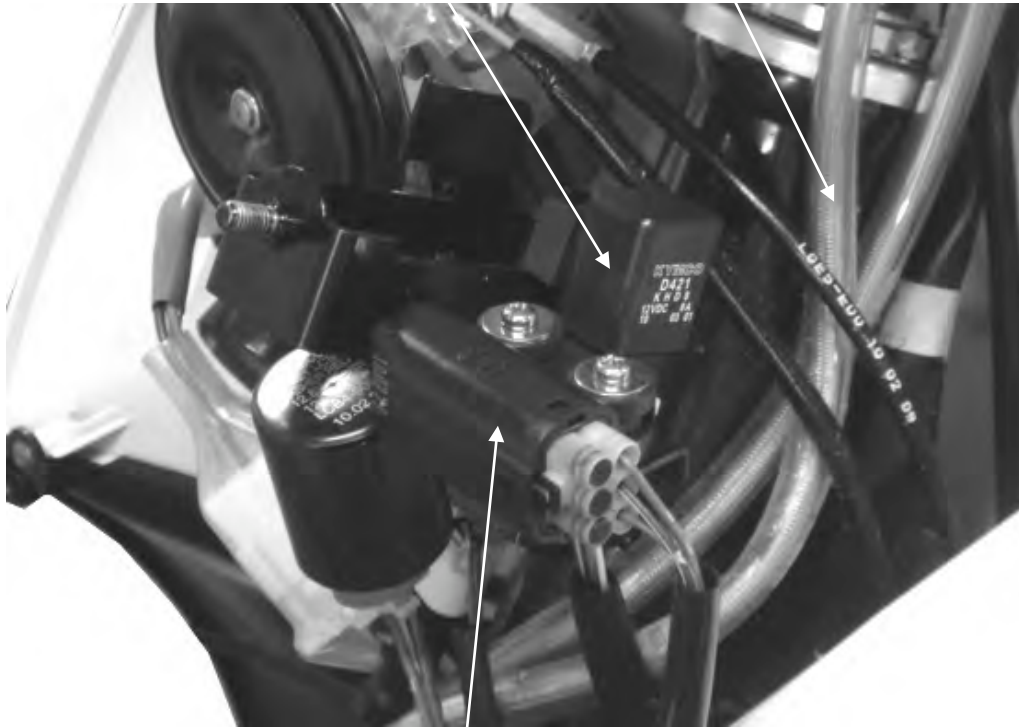

Tilt Switch

MAP Sensor

Throttle Body

ISC

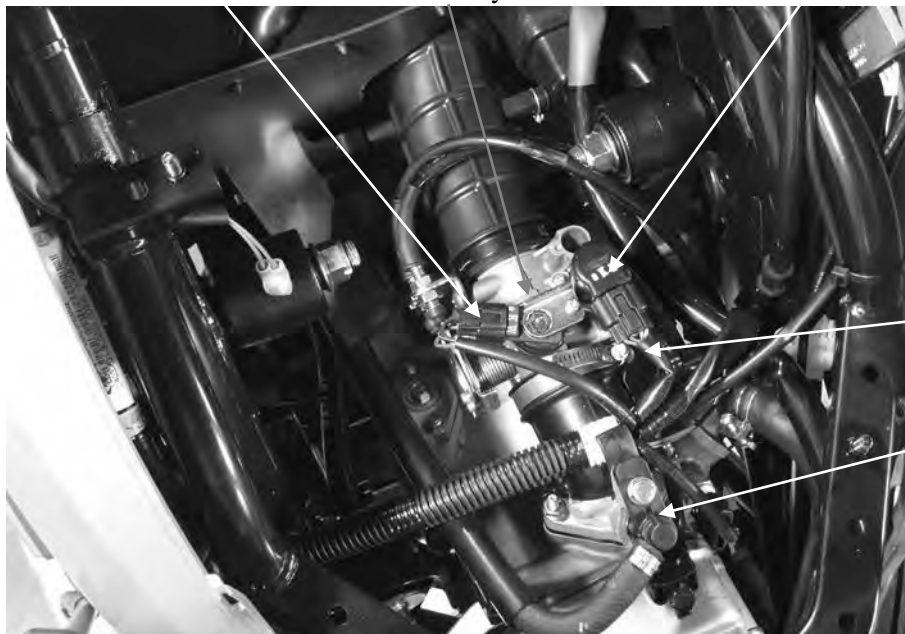

TPS

Injector

1. GENERAL INFORMATION

Ignition Coil



Regulator/Rectifier

TMAP



1. GENERAL INFORMATION

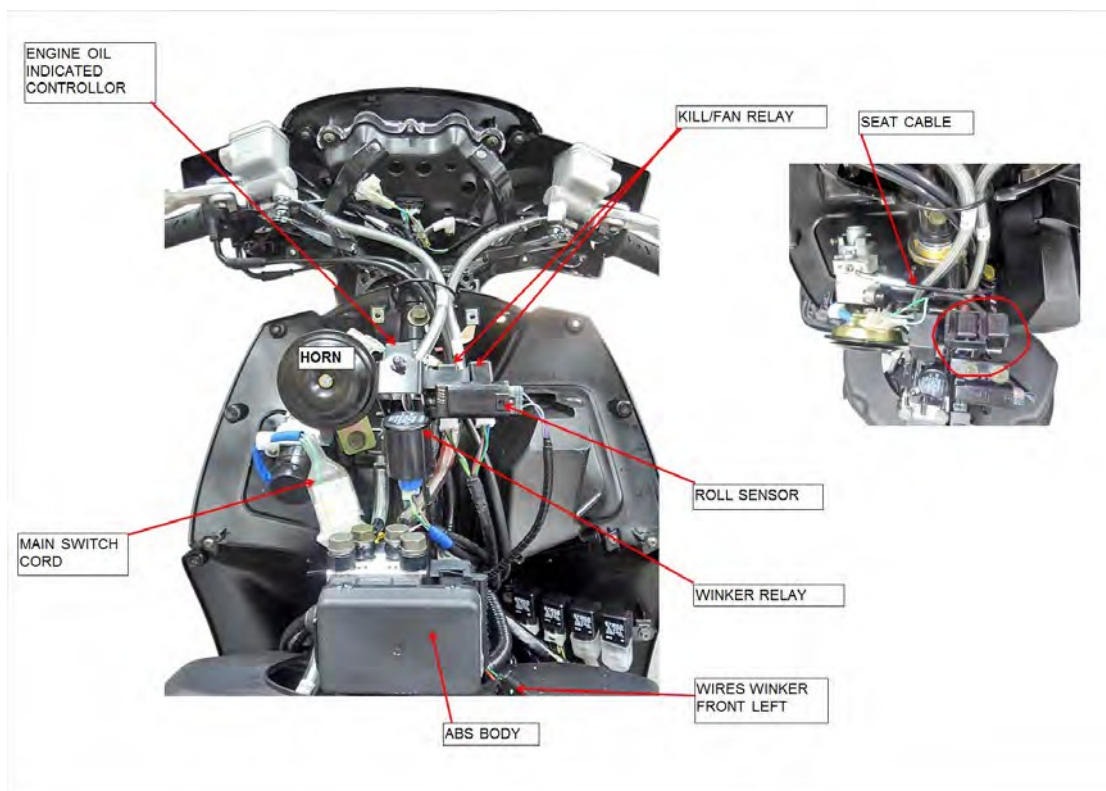
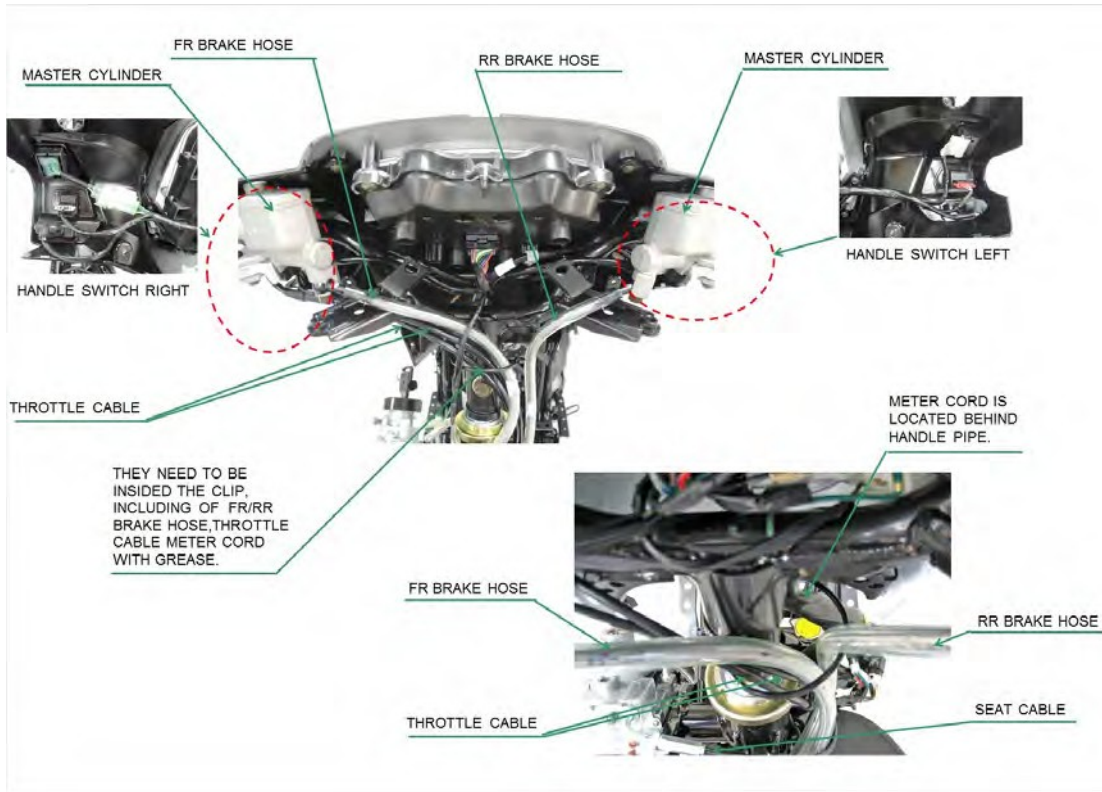

1. GENERAL INFORMATION

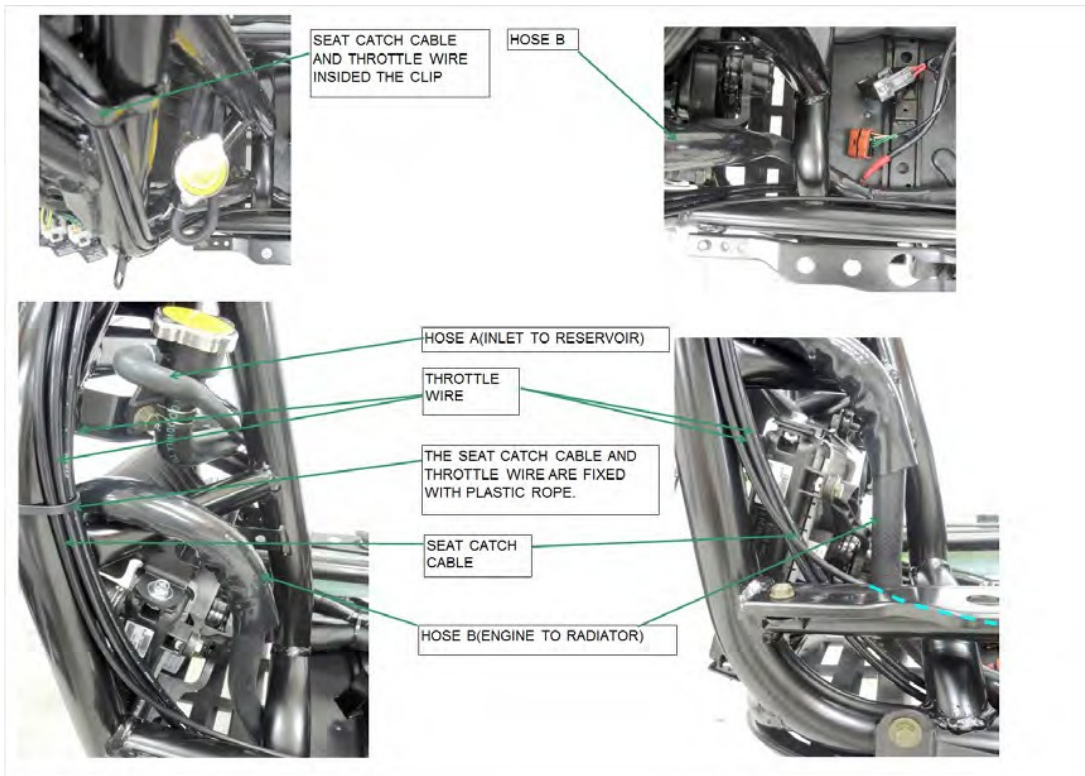
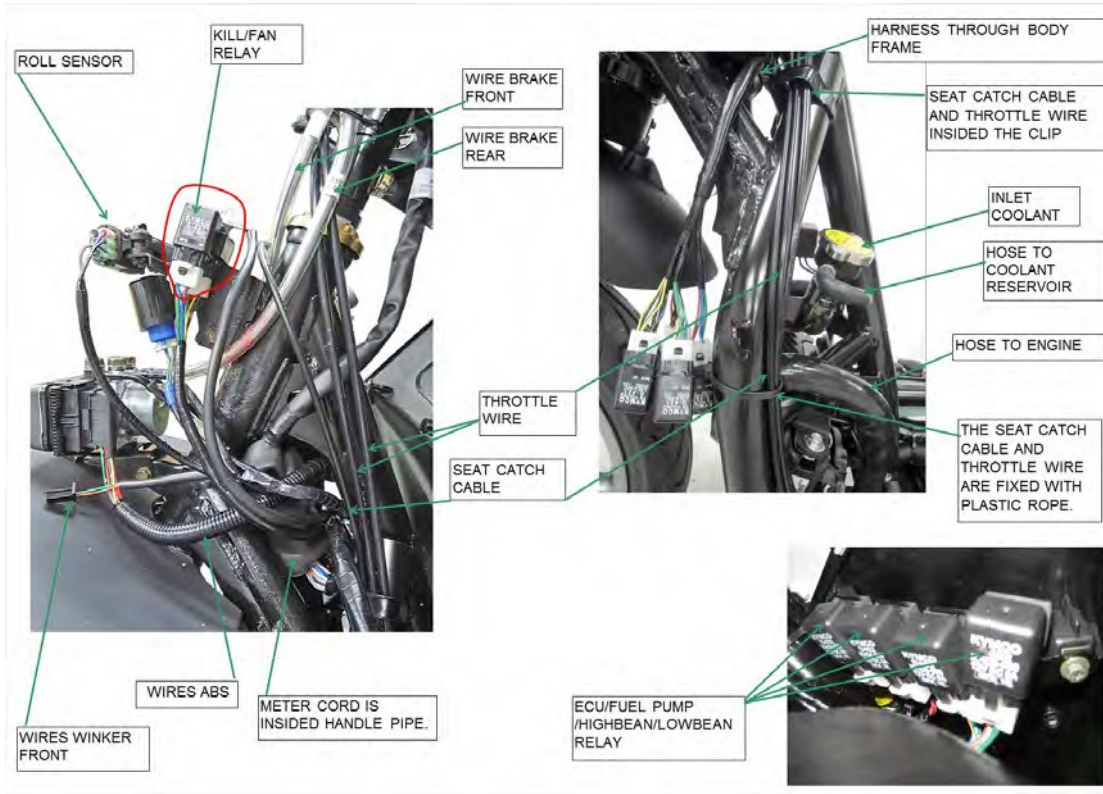

1. GENERAL INFORMATION

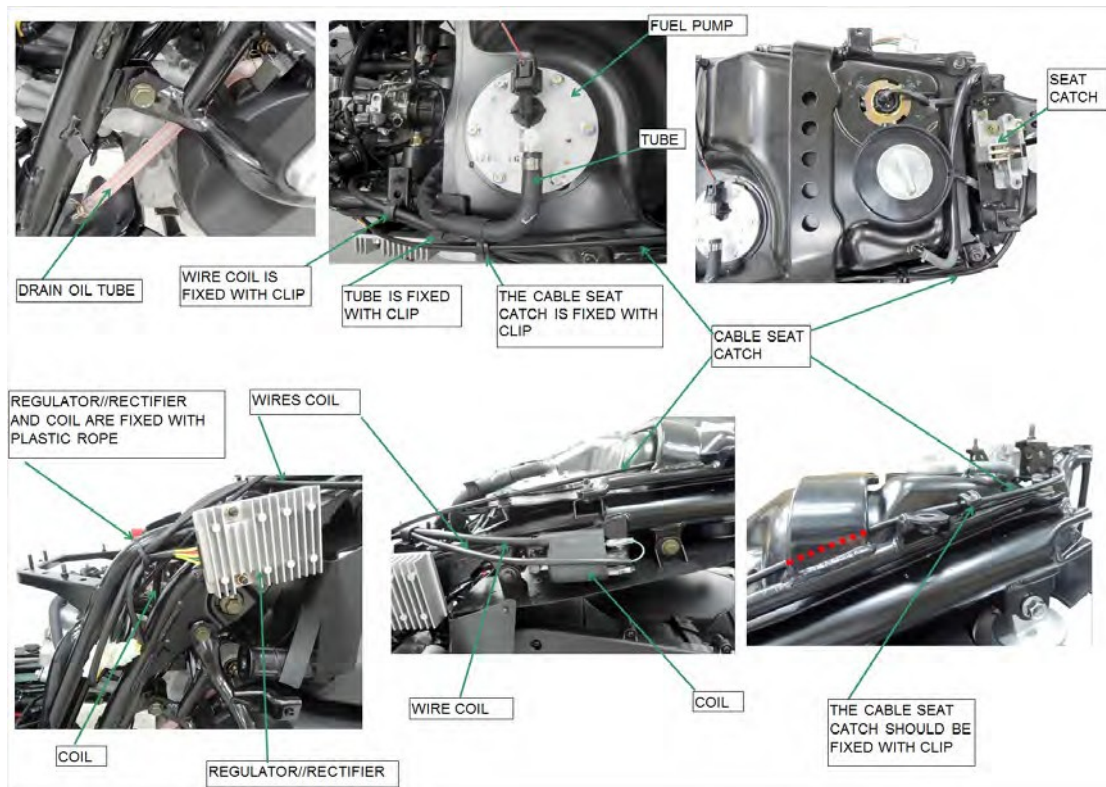
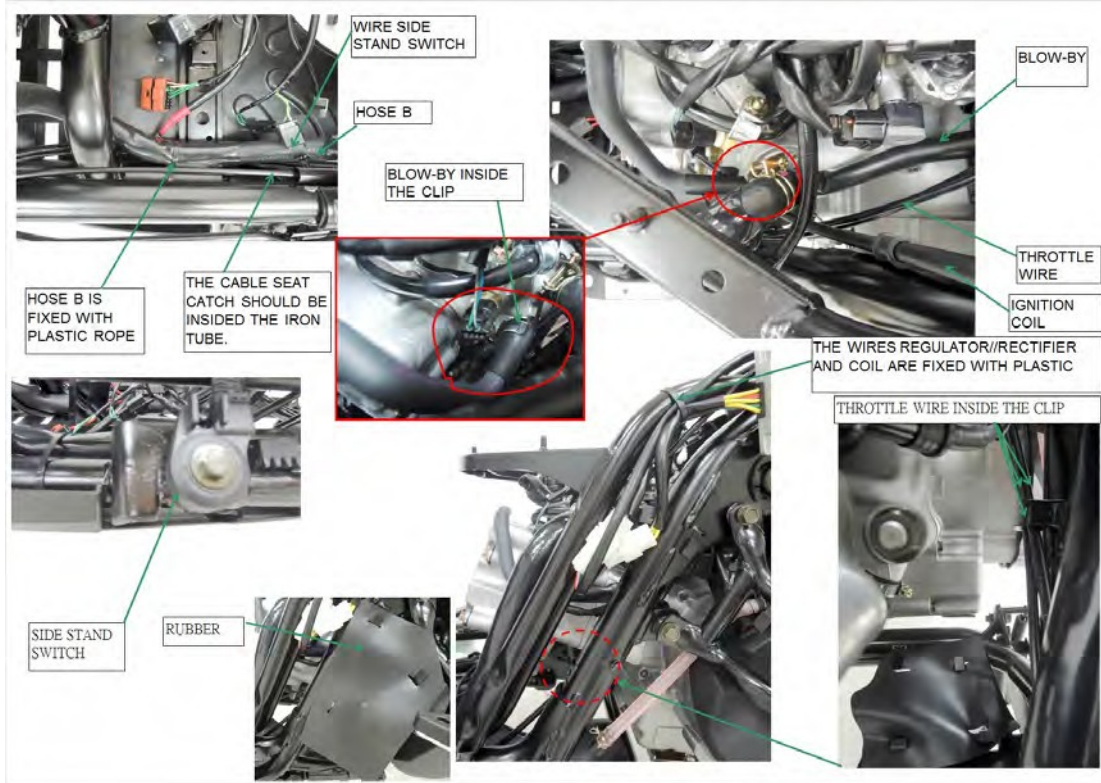

1. GENERAL INFORMATION

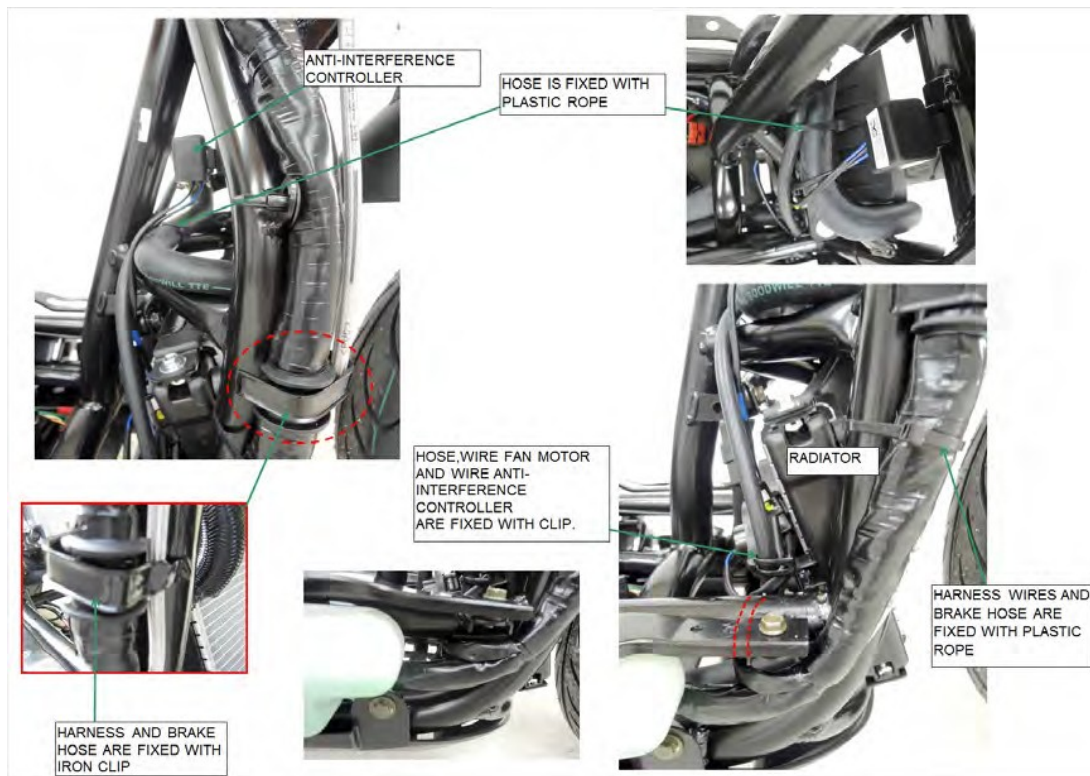
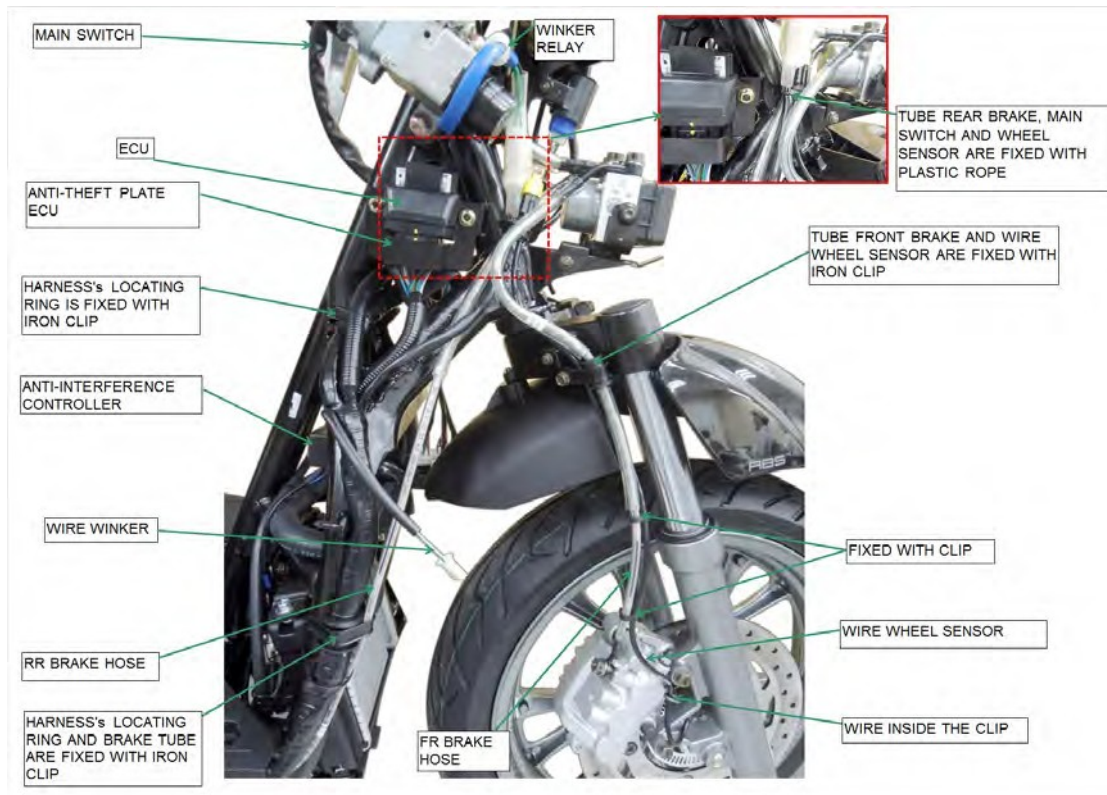

1. GENERAL INFORMATION

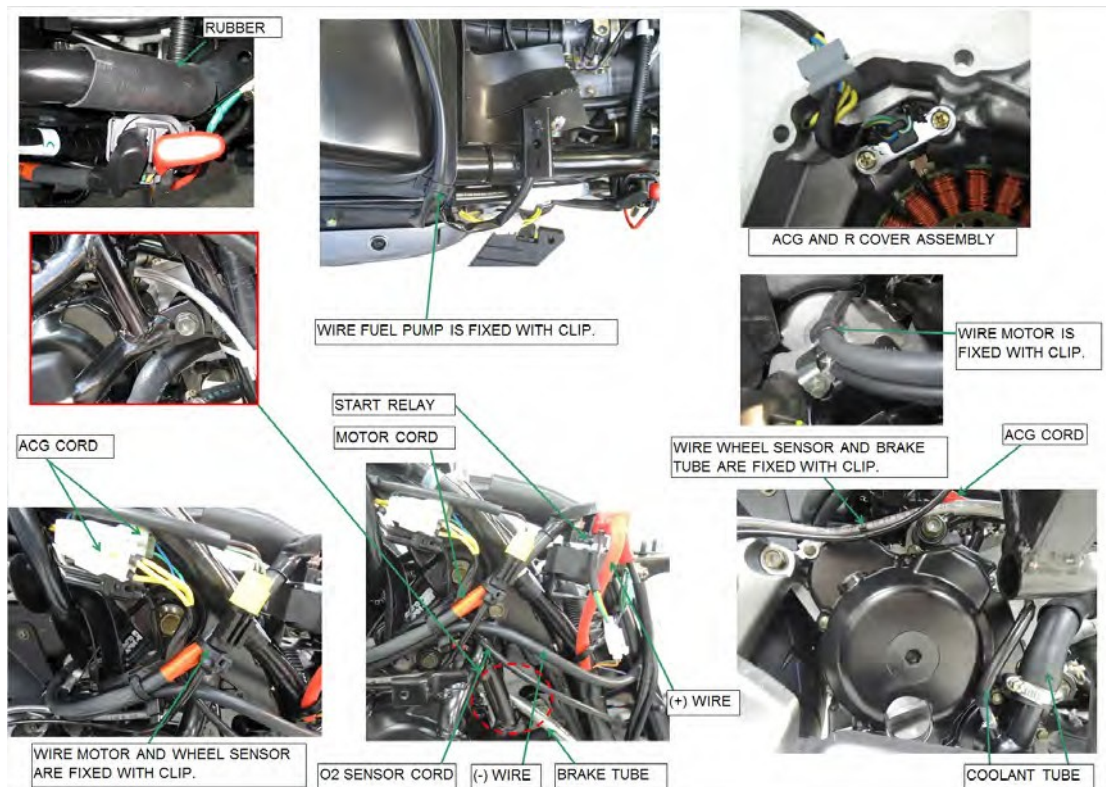
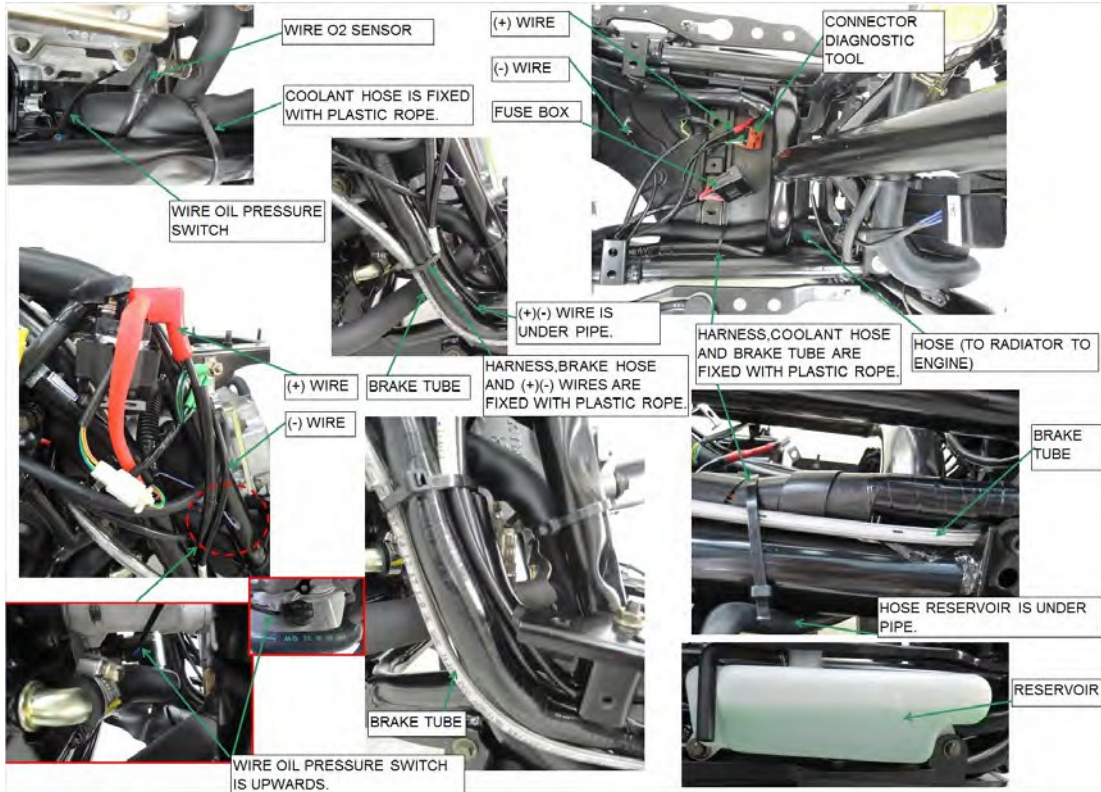

1. GENERAL INFORMATION

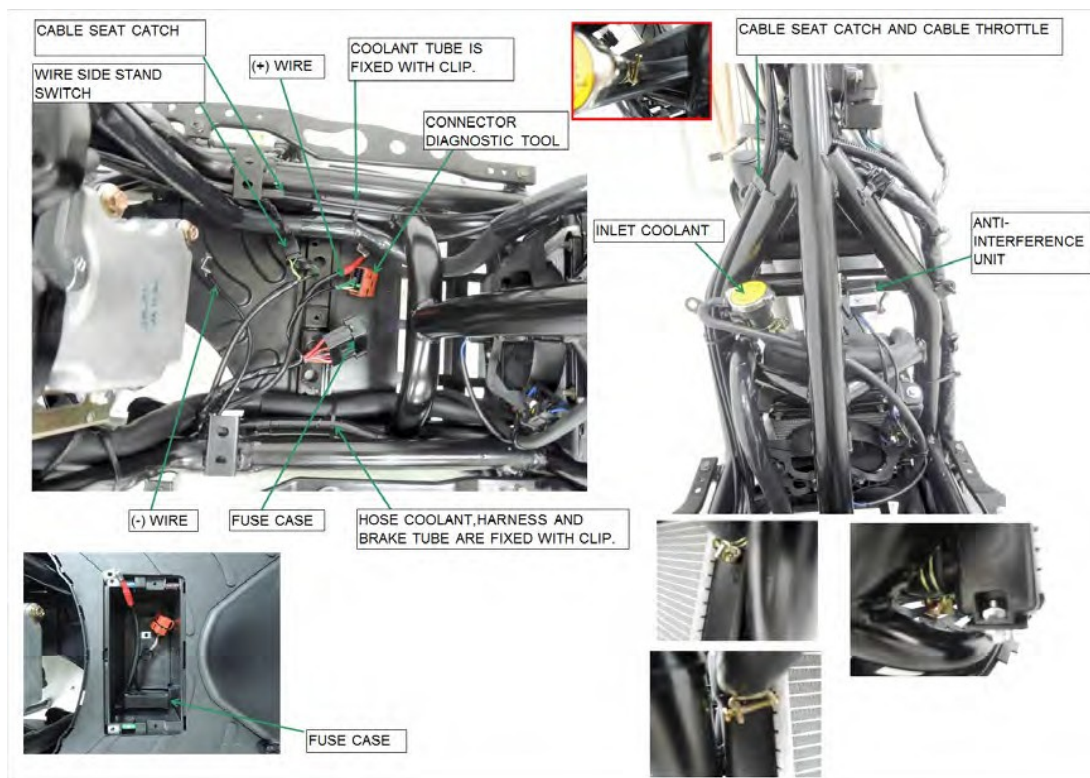
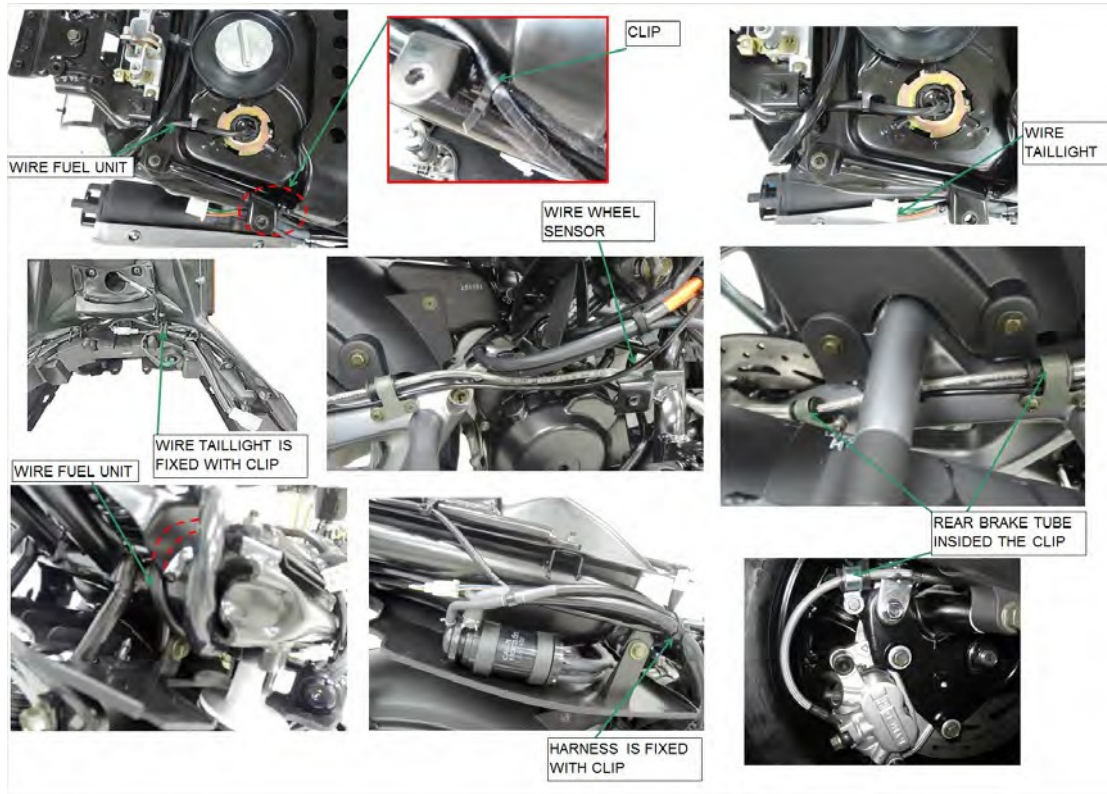

1. GENERAL INFORMATION

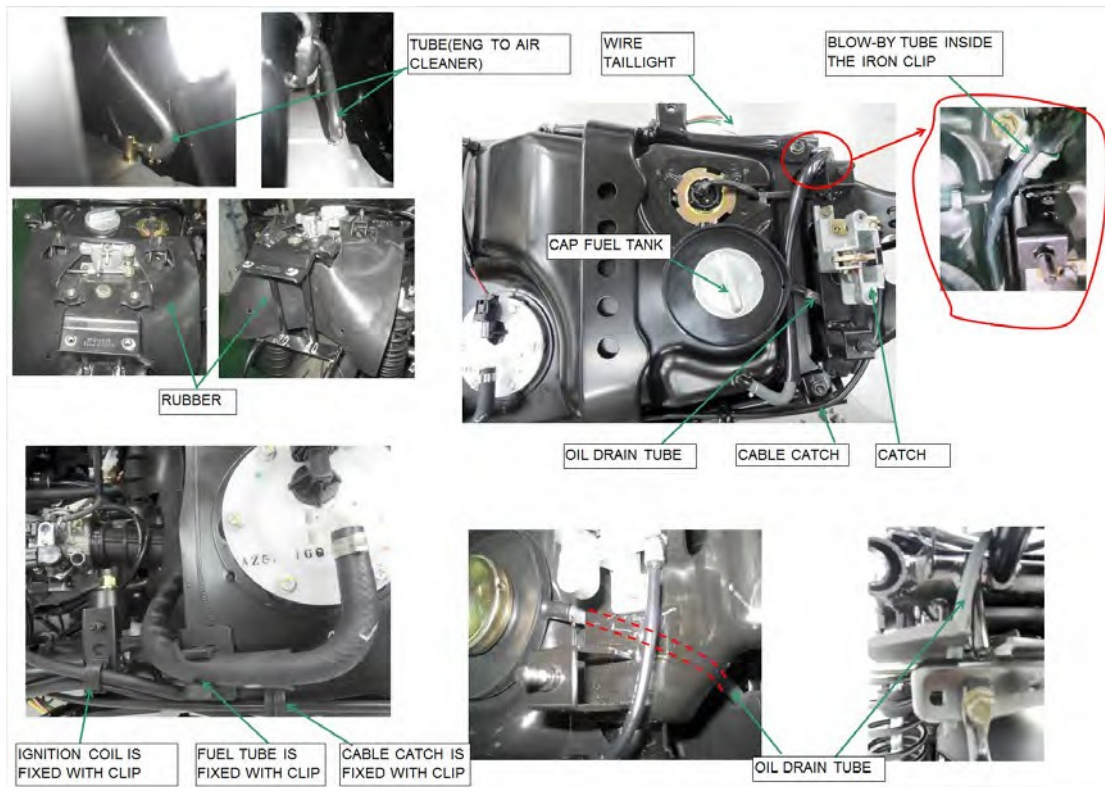
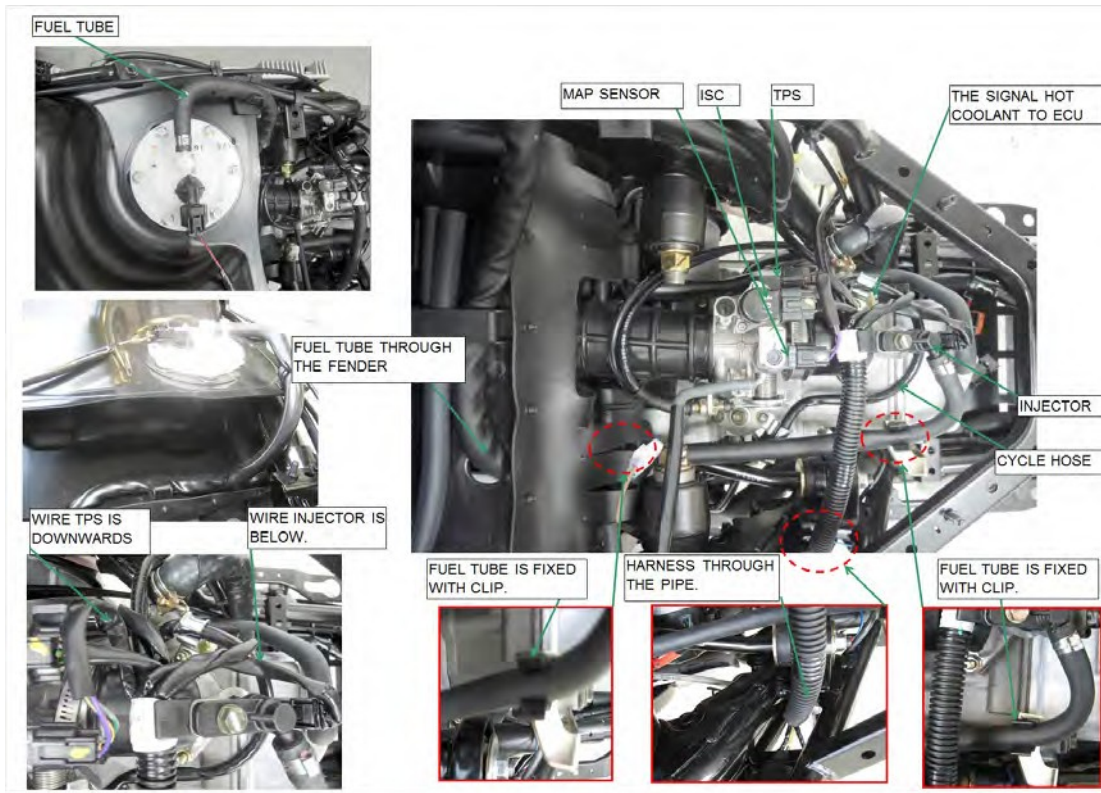

1. GENERAL INFORMATION



1. GENERAL INFORMATION

TROUBLESHOOTING

ENGINE WILL NOT START OR IS HARD TO START

Possible cause

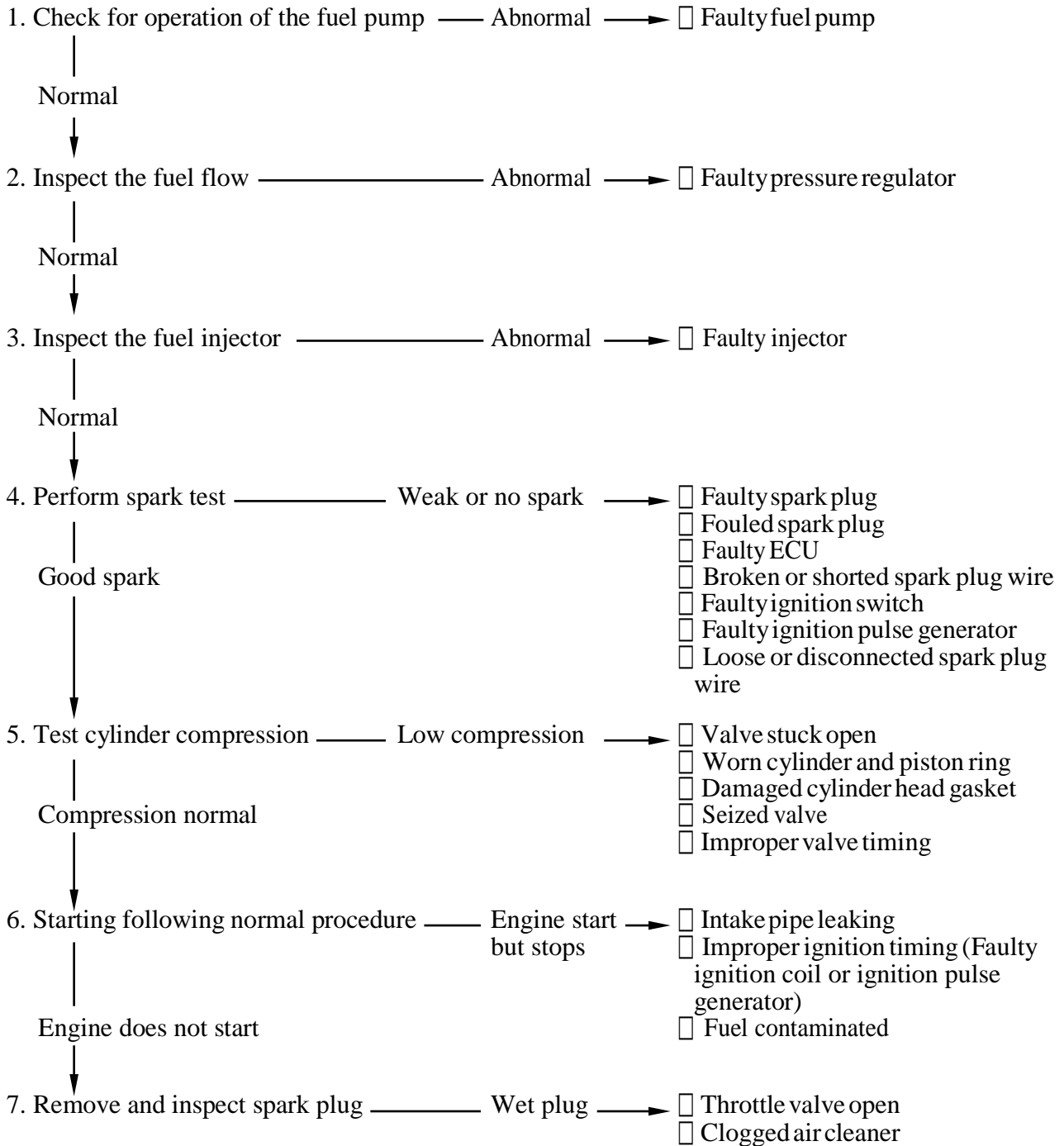

ENGINE LACKS POWER

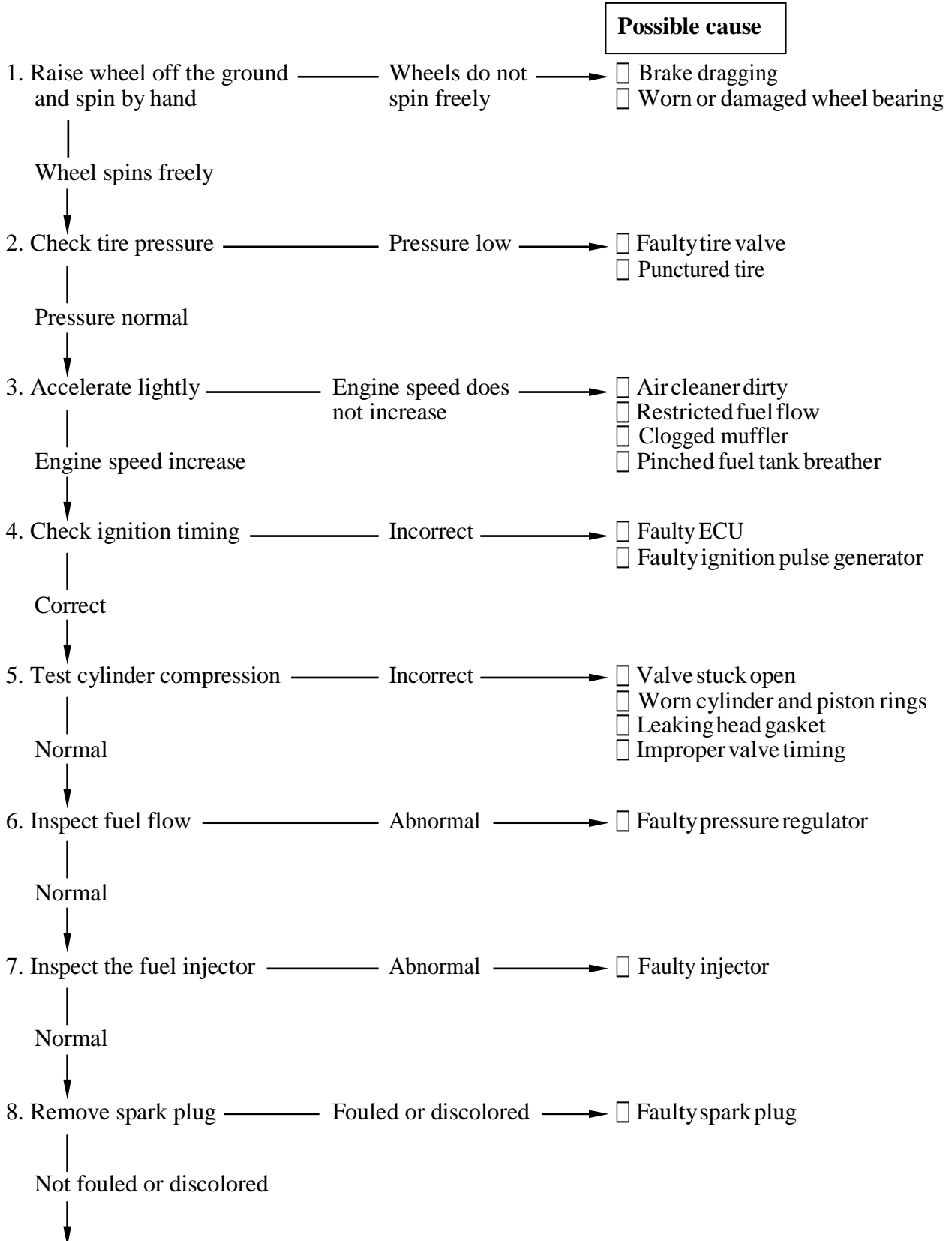

1. GENERAL INFORMATION

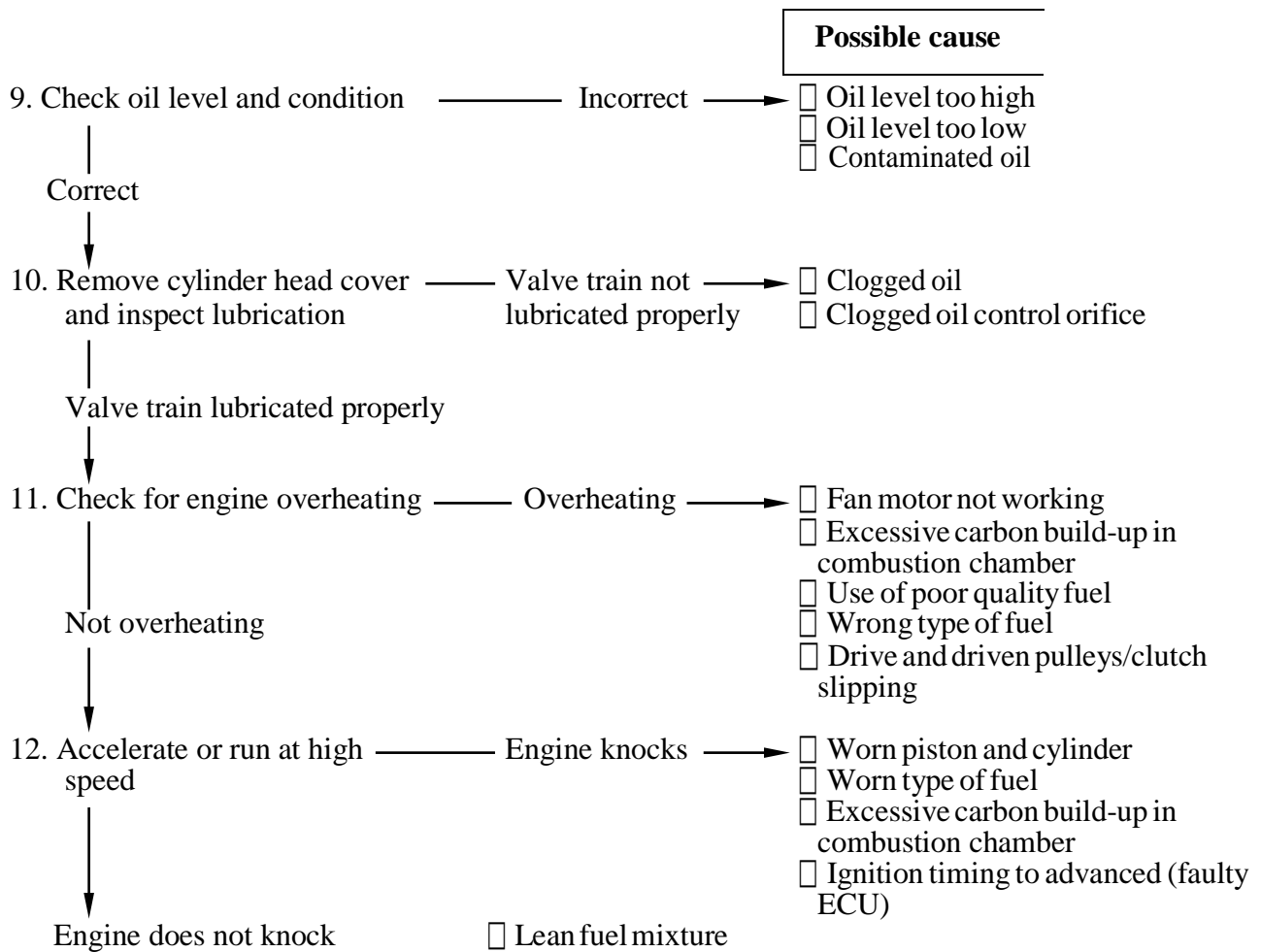

POOR PERFORMANCE AT LOW AND IDLE SPEED

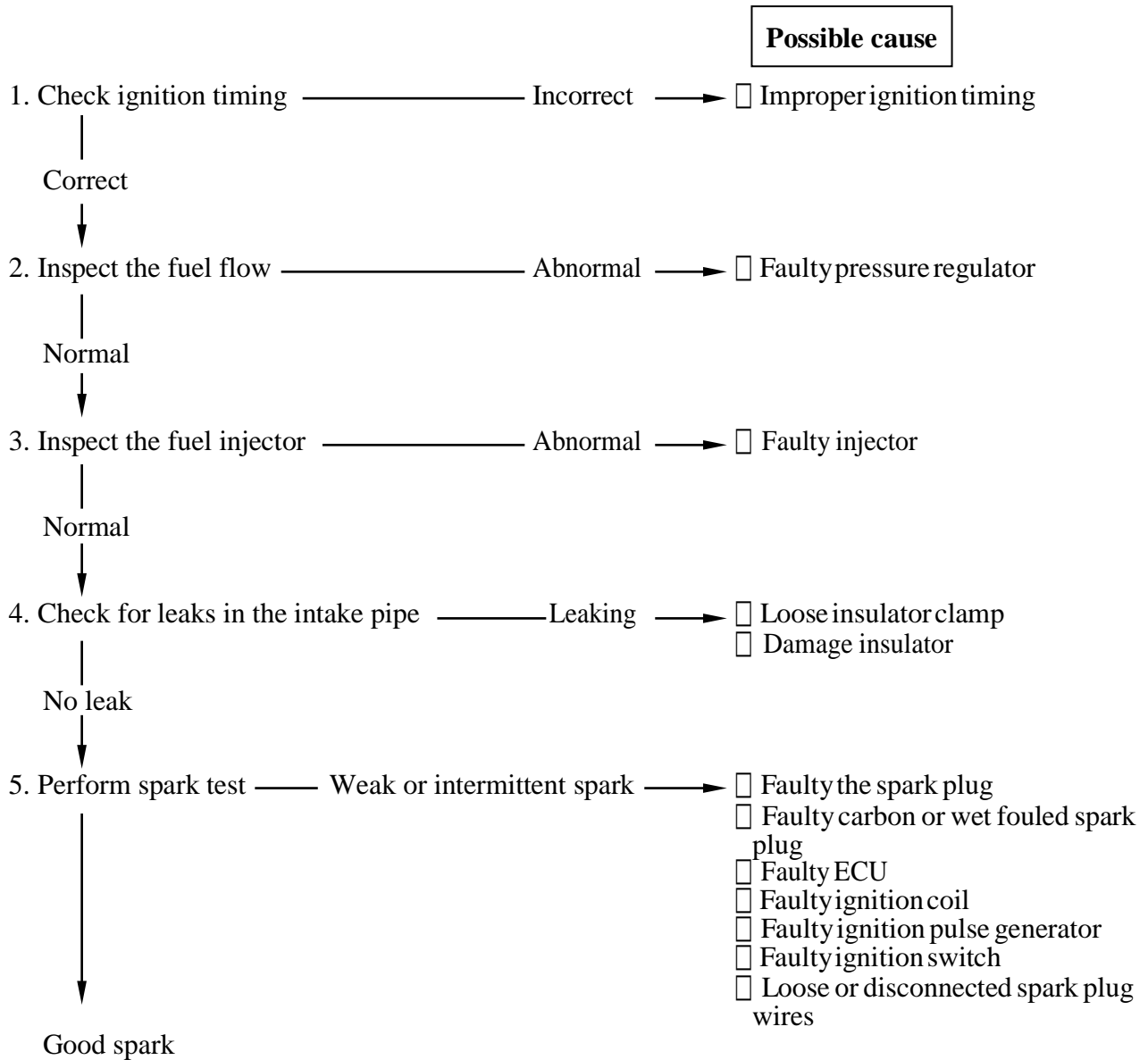

1. GENERAL INFORMATION

POOR PERFORMANCE AT HIGH SPEED

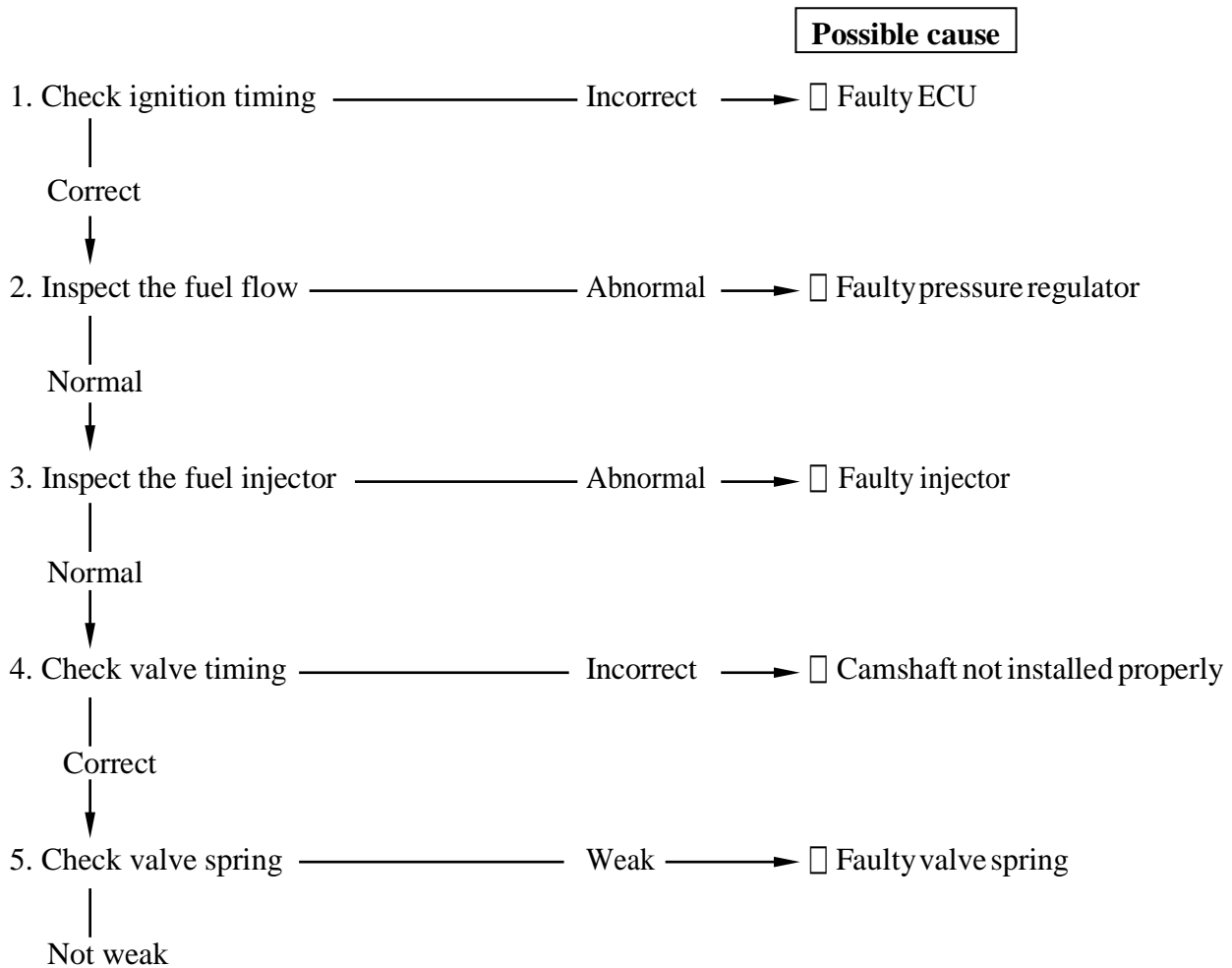

POOR HANDLING

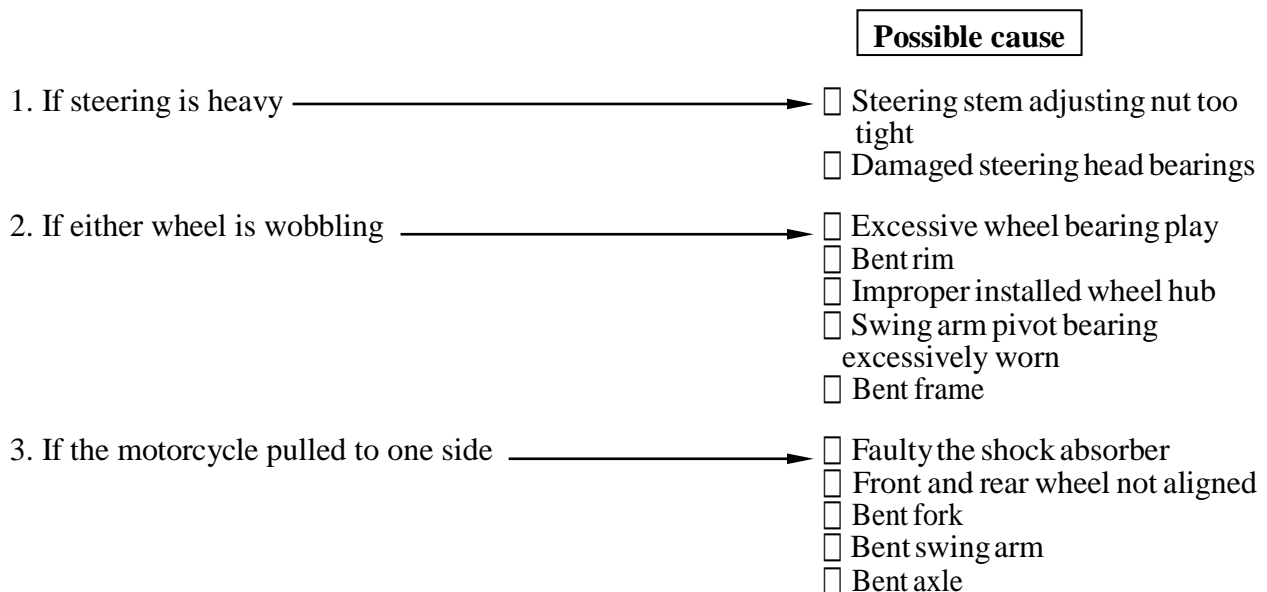

2. EXHAUST MUFFLER/FRAME COVERS People S 300 ABS

2

EXHAUST MUFFLER/FRAME COVERS

SCHEMATIC DRAWING	2-1
SERVICE INFORMATION	2-2
TROUBLESHOOTING	2-2
FRAME COVERS REMOVAL	2-3
EXHAUST MUFFLER REMOVAL	2-6

2. EXHAUST MUFFLER/FRAME COVERS People S 300 ABS

SCHEMATIC DRAWING

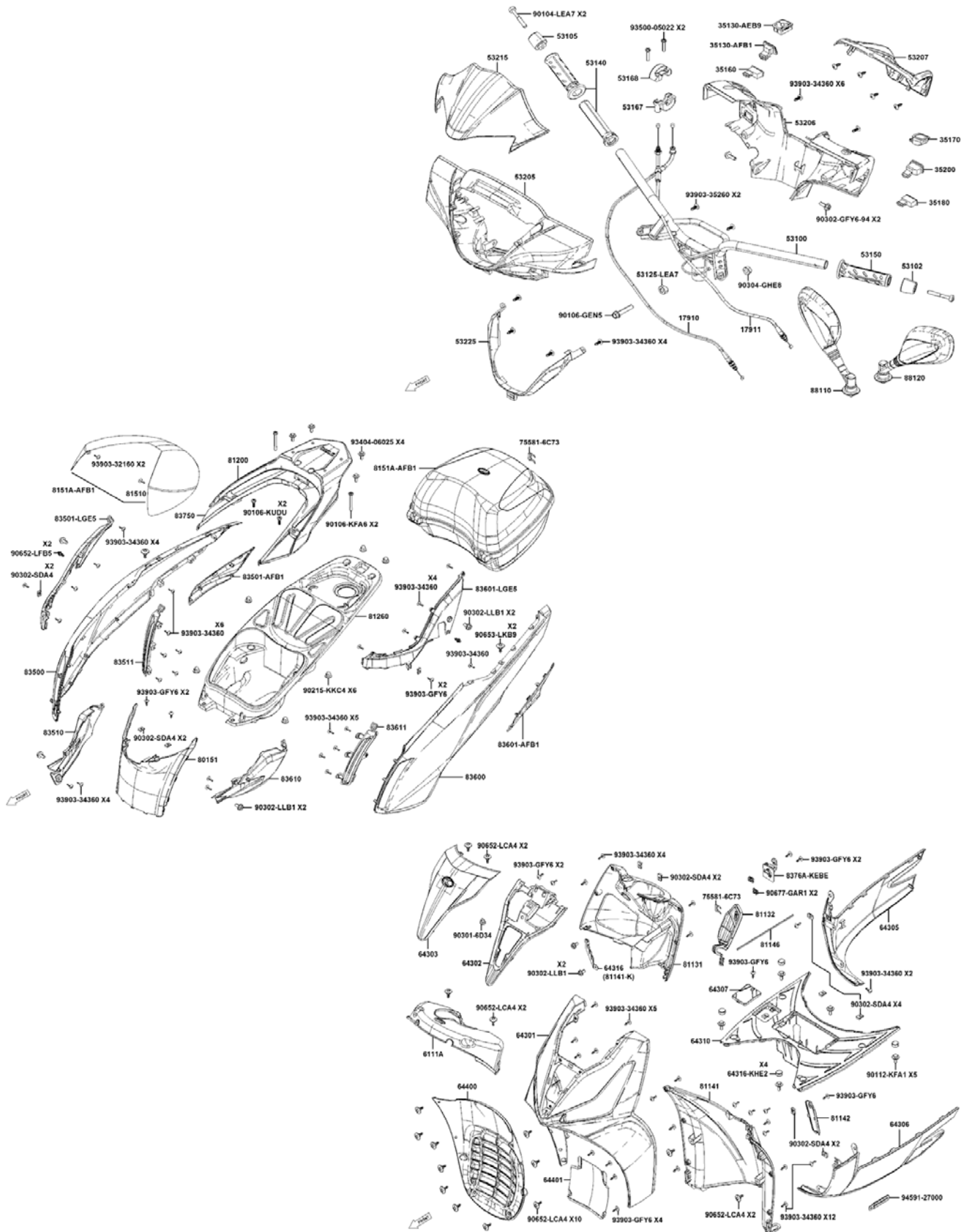

2. EXHAUST MUFFLER/FRAME COVERS People S 300 ABS

SERVICE INFORMATION

GENERAL INSTRUCTIONS

- When removing frame covers, use care not to pull them by force because the cover joint claws may be damaged.
- Make sure to route cables and harnesses according to the Cable & Harness Routing.

TORQUE VALUES

Exhaust muffler lock bolt	35 N-m
Exhaust muffler joint lock nut	20 N-m

TROUBLESHOOTING

Noisy exhaust muffler

- Damaged exhaust muffler
- Exhaust muffler joint air leaks

Lack of power

- Caved exhaust muffler
- Clogged exhaust muffler
- Exhaust muffler air leaks

2. EXHAUST MUFFLER/FRAME COVERS People S 300 ABS

FRAME COVERS REMOVAL

REAR CARRIER

Remove the met-in box.
First remove the eight nuts attaching the met-in box.
Remove the met-in box.



Remove the four bolts attaching the rear carrier.
Remove the rear carrier.

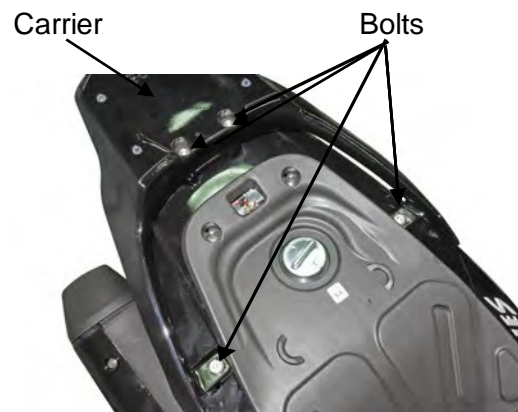

FRAME BODY COVER REMOVAL

Remove the two nuts attaching the rear protective cover.
Remove the rear protective cover.



Remove the center cover.
Remove the body cover.

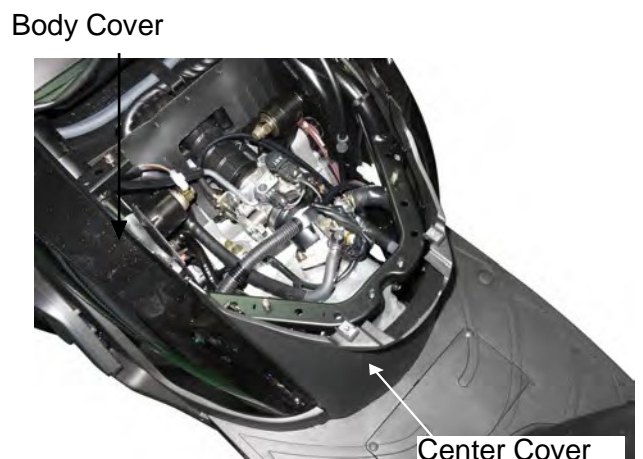

2. EXHAUST MUFFLER/FRAME COVERS People S 300 ABS

FLOOR-FOOT REMOVAL

Remove the screws attaching the right and left side covers.
Remove the right and left side covers by pulling them outward.

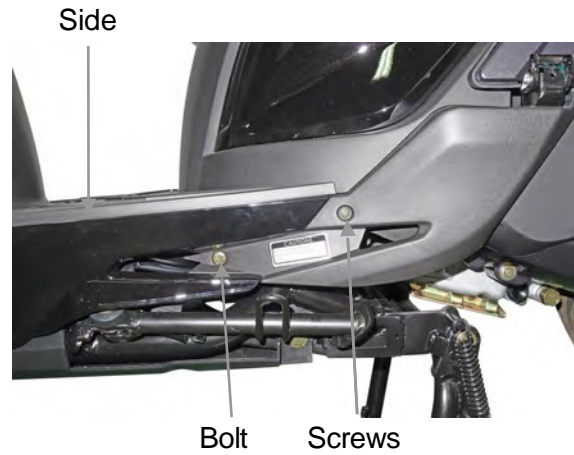

Disconnect the battery wire.
Remove the battery.

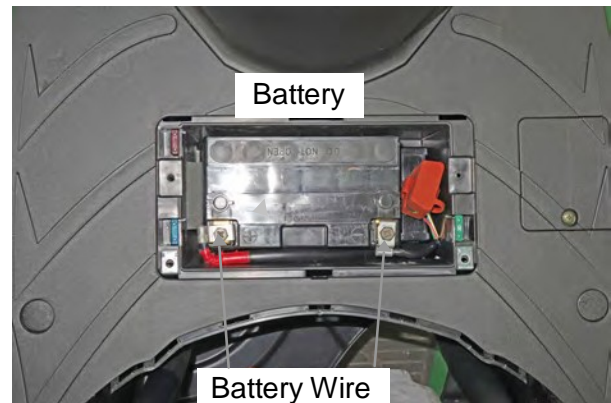

Remove the floor mat.
Remove the center cover. (⇔2-3)
Remove the four bolts attaching the floorboard.
Remove the floorboard.
The installation sequence is the reverse of removal.

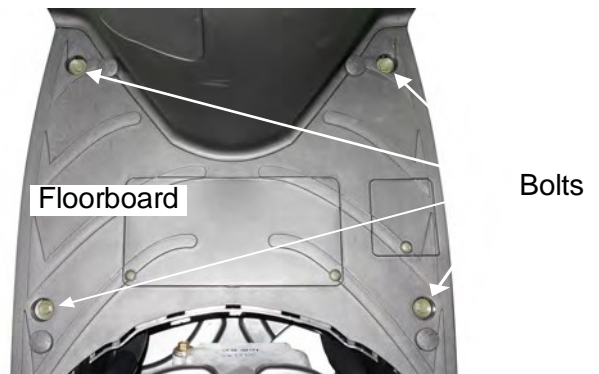

LEG SHIELD REMOVAL

Remove the met-in box.
Remove the body cover.
Remove the floorboard.
Remove the front upper cover.
Remove the screws attaching the leg shield low.
Disconnect the leg shield low with the cowl under cover.
The installation sequence is the reverse of removal.



2. EXHAUST MUFFLER/FRAME COVERS People S 300 ABS

WINDSHIELD REMOVAL

Remove the two bolts attaching the front windshield.
 Remove the windshield cover.
 Remove the windshield.



Windshield

HANDLEBAR COVER REMOVAL

First remove the two bolts attaching the windshield.
 Remove the two screws and four bolts attaching the handlebar rear cover.
 Remove the handlebar rear cover.
 The installation sequence is the reverse of removal.

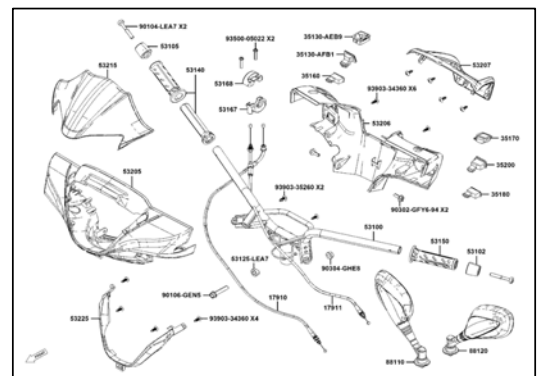

Handlebar Cover

Remove the two screws attaching the handlebar cover.
 Remove the handlebar cover.
 The installation sequence is the reverse of removal.



Screws

BOTTOM COVER REMOVAL

Remove the four bolts attaching the bottom cover.
 Remove the bottom cover.



Bottom Cover

Bolts

2. EXHAUST MUFFLER/FRAME COVERS People S 300 ABS

EXHAUST MUFFLER REMOVAL

Remove three lock nuts from joint in the exhaust muffler.

Remove the exhaust muffler two lock bolts to remove the exhaust muffler.

Remove the exhaust muffler joint packing collar.

The installation sequence is the reverse of removal.

Torque:

Exhaust muffler lock bolt	35 N-m
Exhaust muffler joint lock nut	20 N-m

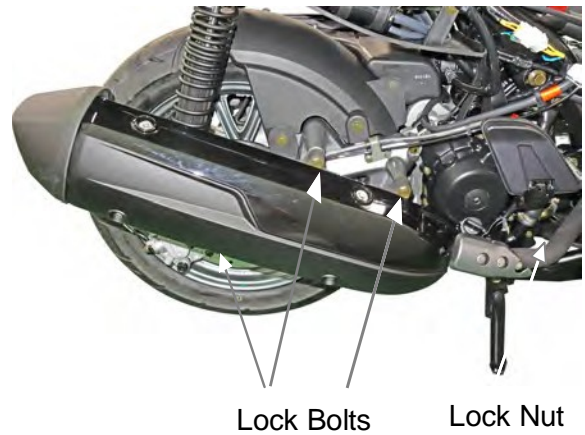

3. INSPECTION/ADJUSTMENT

3

INSPECTION / ADJUSTMENT

SERVICE INFORMATION	3- 1
MAINTENANCE SCHEDULE.....	3- 2
THROTTLE OPERATION.....	3- 3
ENGINE OIL	3- 4
RESERVE TANK	3- 5
AIR CLEANER	3- 6
SPARK PLUG	3- 6
VALVE CLEARANCE.....	3- 7
CYLINDER COMPRESSION	3- 7
FINAL REDUCTION GEAR OIL	3- 8
DRIVE BELT.....	3- 8
BRAKE SYSTEM.....	3- 9
CLUTCH SHOE WEAR.....	3-10
SUSPENSION.....	3-10
NUTS/BOLTS/FASTENERS.....	3-11
WHEELS/TIRES.....	3-11
STEERING HANDLEBAR.....	3-11
SIDE STAND	3-12

3. INSPECTION/ADJUSTMENT

SERVICE INFORMATION

GENERAL

 WARNING
--

- Before running the engine, make sure that the working area is well ventilated. Never run the engine in a closed area. The exhaust contains poisonous carbon monoxide gas, which may cause death to people.
- Gasoline is extremely flammable and is explosive under some conditions. The working area must be well ventilated and do not smoke or allow flames or sparks near the working area or fuel storage area.

SPECIFICATIONS

ENGINE

Throttle grip free play : 2~6 mm
 Spark plug : NGK: CR7E
 Spark plug gap : 0.7 mm ~ 0.8mm
 Valve clearance IN: 0.10 mm EX: 0.10 mm
 Idle speed : 1600±100 rpm

Engine oil capacity:

Cylinder compression: 16±2 kg/cm²
 At disassembly : 1.5 Liter Ignition timing : ECU
 At change : 1.3 Liter Coolant type : Water Cooling

Gear oil capacity :

At disassembly : 0.23 Liter
 At change : 0.20 Liter

TIRE

	1 Rider	2 Riders
Front	1.75 kg/cm ²	2.00 kg/cm ²
Rear	1.75 kg/cm ²	2.25 kg/cm ²

TIRE SPECIFICATION

Front : 110/70-16
 Rear : 140/70-16

TORQUE VALUES

Front axle nut : 20 N-m
 Rear axle nut : 120 N-m

SPECIAL TOOL

Tappet Adjuster E012

3. INSPECTION/ADJUSTMENT

Maintenance schedule

Perform the pre-ride inspection (see page 21) at each scheduled maintenance period. This interval should be judged by odometer reading or months, whichever comes first.

Maintenance schedule legend

I: INSPECT AND CLEAN, ADJUST, LUBRICATE OR REPLACE IF NECESSARY

C: CLEAN R: REPLACE A: ADJUST L: LUBRICATE

The maintenance schedule on the following two pages specifies the maintenance required to keep your **DOWNTOWN 300i** scooter in peak operating condition. Maintenance work should be performed in accordance with KYMCO standards and specifications by properly trained and equipped technicians. Your KYMCO dealer meets all of these requirements.

- * Should be serviced by your KYMCO dealer, unless you have the proper tools, service data and are technically qualified.
- ** In the interest of safety, we recommend these items be serviced only by your KYMCO dealer. KYMCO recommends that your KYMCO dealer road test your scooter after each periodic maintenance service is completed.

ITEM	FREQUENCY	WHICHEVER COMES FIRST		ODOMETER READING							
		→									
		X 1000 km		1	5	10	15	20	25	30	
		X 1000 mi		0.6	3	6	9	12	15	18	
		MONTH	1	6	12	18	24	30	36		
*	AIR CLEANER				R	R	R	R	R	R	R
	SPARK PLUGS				I	R	I	R	I	R	
*	THROTTLE OPERATION				I	I	I	I	I	I	
*	VALVE CLEARANCE				I	A	I	A	I	A	
*	FUEL LINE					I		I		I	
	CRANKCASE BREATHER			C	C	C	C	C	C	C	
*	ENGINE OIL			R	R	R	R	R	R	R	
*	ENGINE OIL SCREEN				C	R	C	R	C	R	
*	ENGINE OIL FILTER			R	R	R	R	R	R	R	
*	ENGINE IDLE SPEED					I		I		I	
*	TRANSMISSION OIL			R	R	R	R	R	R	R	
*	DRIVE BELT				I	I	I	I	I	I	
**	CLUTCH SHOE WEAR					I		I		I	
	BRAKE FLUID				I	R	I	R	I	R	
	BRAKE PAD WEAR				I	I	I	I	I	I	
	BRAKE SYSTEM				I	I	I	I	I	I	
*	BRAKE LIGHT SWITCH				I	I	I	I	I	I	
**	STEERING BEARINGS				I	I	I	I	I	I	
*	HEADLIGHT AIM				I	I	I	I	I	I	
*	NUTS, BOLTS, FASTENERS				I	I	I	I	I	I	
**	WHEELS/TIRES				I	I	I	I	I	I	
**	COOLANT				I	R	I	R	I	R	

3. INSPECTION/ADJUSTMENT

THROTTLE OPERATION

Check the throttle grip for smooth movement.
Measure the throttle grip free play.

Free Play: 2~6 mm

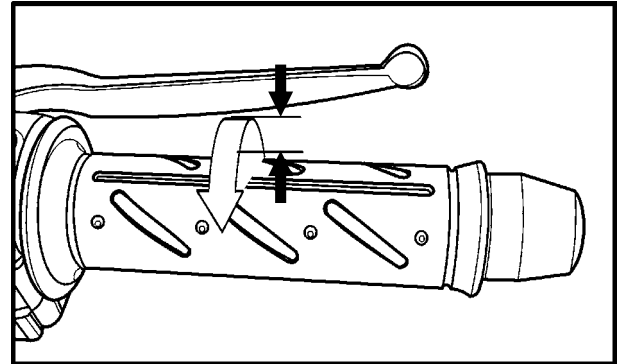

Adjusting Nut

Major adjustment of the throttle grip free play is made with the adjusting nut at the throttle body side. Adjust by loosening the lock nut and turning the adjusting nut.

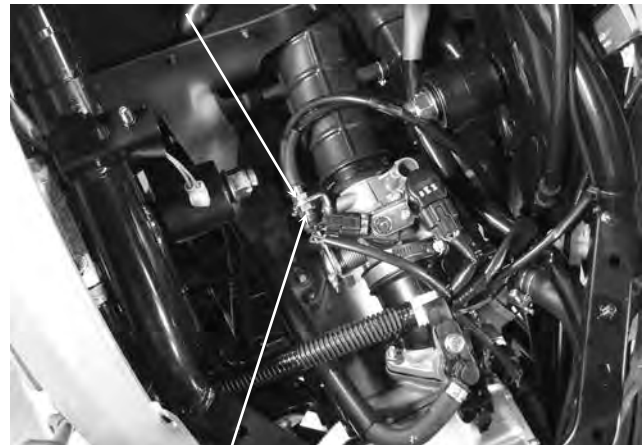

Lock Nut

Minor adjustment is made with the adjusting nut at the throttle grip side.

Slide the rubber cover out and adjust by loosening the lock nut and turning the adjusting nut.

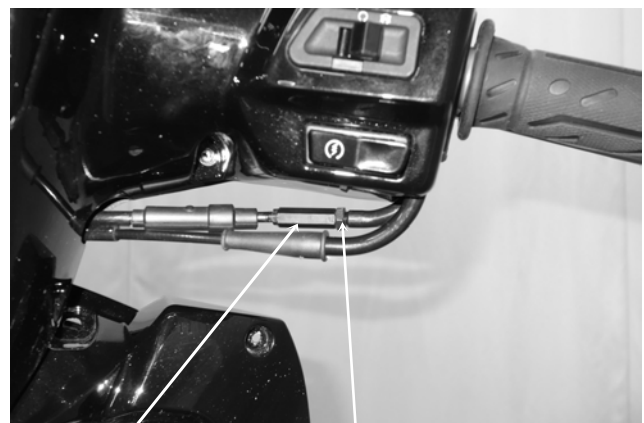

Adjusting Nut

Lock Nut

3. INSPECTION/ADJUSTMENT

ENGINE OIL

OIL LEVEL INSPECTION

Stop the engine and support the scooter upright on the level ground.
Wait for 2~3 minutes and check the oil level with the dipstick. Do not screw in the dipstick when checking the oil level.



Dipstick

OIL CHANGE

Remove the oil drain bolt to drain the engine oil.
Install the aluminum washer and tighten the oil drain bolt.

Torque: 2.5 kg-m

- * Replace the aluminum washer with a new one if it is deformed or damaged.

Pour the recommended oil through the oil filler hole.



Oil Drain Bolt

OIL CAPACITY

Engine oil capacity: 1.5 L
Engine oil exchanging capacity: 1.3 L
Engine Oil Viscosity : SAE 5W50

OIL FILTER SCREEN INSPECTION

Drain the engine oil.
Remove the oil filter screen attaching the left-under crankcase.
Clean the oil filter screen.
Install the oil filter screen and filter screen cap.
Fill the engine with recommended engine oil.



Oil Filter Screen

OIL FILTER REPLACEMENT

Remove the oil filler cap attaching the right-under crankcase cover.

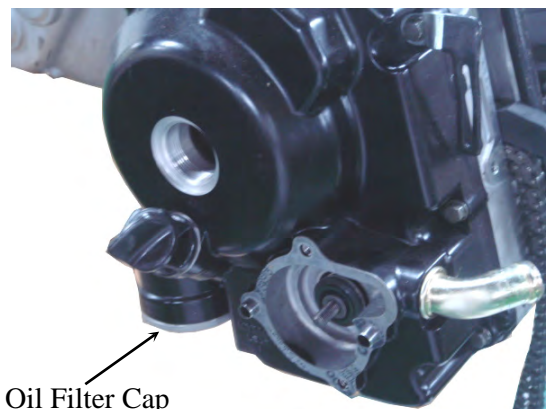

Oil Filter Cap

3. INSPECTION/ADJUSTMENT

The spring will come out when the filter cap is removed.

Let the engine oil drain out.

Check that the O-ring is in good condition.



Spring

Install a new oil filter.

* Make sure the rubber seal on the oil filter facing the left crankcase.



RESERVE TANK COOLANT LEVEL INSPECTION

The reserve tank is under left floorboard. Check the coolant level through the inspection window at the left side skirt while the engine is at the normal operating temperature, with the scooter in an upright position.

If the coolant level is below the LOWER level mark, remove the left floor mat, remove the lid screw, the reserve tank lid, and then the reserve tank cap to add coolant mixture until it reaches the upper level mark.

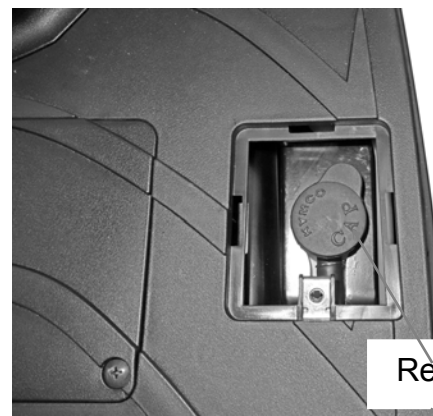

Reserve Tank

* Add coolant to the reserve tank only. Do not attempt to add coolant by removing the radiator cap. Coolant in the radiator is under pressure and is very hot and can cause serious burns.



3. INSPECTION/ADJUSTMENT

AIR CLEANER

AIR FILTER REPLACEMENT

Remove the body cover.
 Remove seven screws attaching to the air cleaner cover.
 Remove six screws attaching to the filter.
 Check the filter and replace it if it is excessively dirty or damaged.

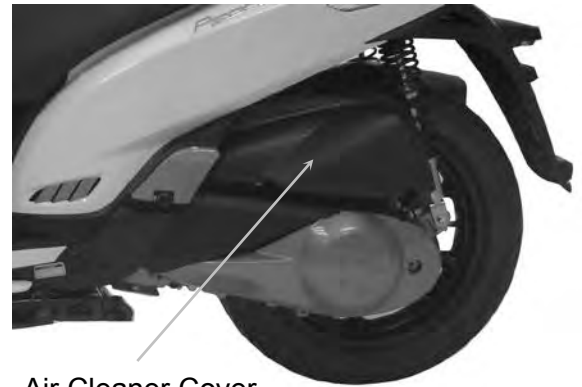

Air Cleaner Cover

CHANGE INTERVAL

More frequent replacement is required when riding in unusually dusty or rainy areas.

- *
 • The air cleaner element has a viscous type paper element. Do not clean it with compressed air.
 • Be sure to install the air cleaner element and cover securely.

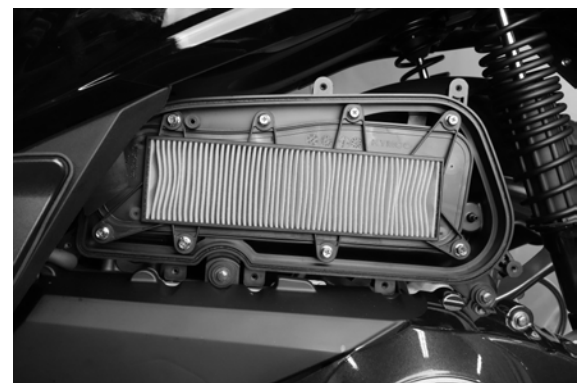

SPARK PLUG

Remove the spark plug cap and spark plug.
 Check the spark plug for wear and fouling deposits.
 Clean any fouling deposits with a spark plug cleaner or a wire brush.

Specified Spark Plug: NGK-CR7E

Measure the spark plug gap.

Spark Plug Gap: 0.7 – 0.8 mm



Spark Plug

- *
 • When installing, first screw in the spark plug by hand and then tighten it with a spark plug wrench.

Torque: 17.2 N-m

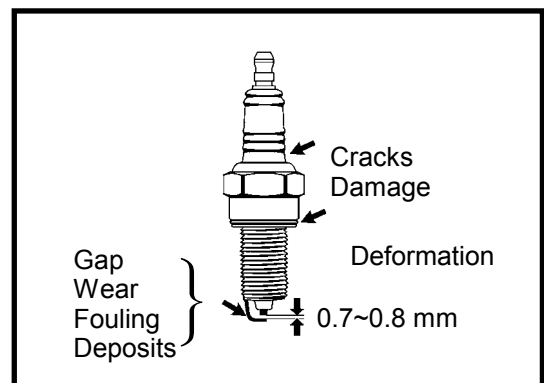

3. INSPECTION/ADJUSTMENT

VALVE CLEARANCE

- * • Inspect and adjust valve clearance while the engine is cold (below 35°C).

Remove the seat assy and luggage box.
Remove the four bolts and then cylinder head cover.

Turn the A.C. generator flywheel to the top dead center (TDC) on the compression stroke so that the "T" mark on the flywheel aligns with the index mark on the left crankcase cover.
Inspect and adjust valve clearance.

Valve Clearance: IN: 0.10 mm
EX: 0.10 mm

Loosen the lock nut and adjust by turning the adjusting nut

Special

Valve Adjuster E012
Feeler Gauge

- * • Check the valve clearance again after the lock nut is tightened.

Cylinder Head Cover

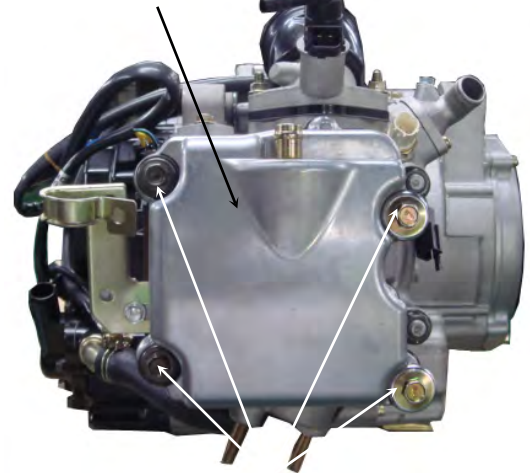

Bolts

Top Dead Center Mark



CYLINDER COMPRESSION

Warm up the engine before compression test.

Remove the center cover and luggage box.
Remove the spark plug.
Insert a compression gauge.
Open the throttle fully and push the starter button to test the compression.

Max. Compression: 16±2 kg/cm² - 570 rpm

If the compression is low, check for the following:

- Leaky valves
- Valve clearance too small
- Leaking cylinder head gasket
- Worn piston rings
- Worn piston/cylinder

If the compression is high, it indicates that carbon deposits have accumulated on the combustion chamber and the piston head.



3. INSPECTION/ADJUSTMENT

FINAL REDUCTION GEAR OIL

- * • Place the scooter on its main stand on level ground.

Remove the transmission fluid drain bolt.
Remove the transmission fluid filler bolt, then slowly rotate the rear wheel to drain the fluid.
Fill the transmission with the recommend fluid to the capacity listed below.

Transmission fluid type: SAE 90

Transmission fluid capacity: 0.23 L

Transmission fluid exchanging capacity: 0.20 L

Install the transmission filler bolt and tighten it to the specified torque.



Oil Drain Bolt

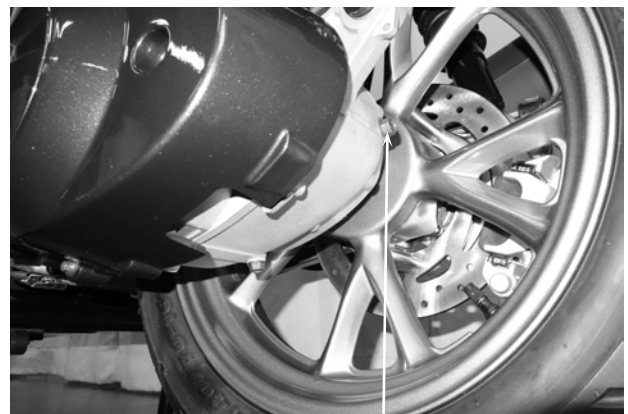

Oil Filler Bolt

DRIVE BELT

Remove the left crankcase cover.
Inspect the drive belt for cracks or excessive wear.

Replace the drive belt with a new one if necessary and in accordance with the Maintenance Schedule.



Drive Belt

3. INSPECTION/ADJUSTMENT

BRAKE SYSTEM

BRAKE DISK/BRAKE PAD

Check the brake disk surface for scratches, unevenness or abnormal wear.

Check if the brake disk runout is within the specified service limit.

Check if the brake pad wear exceeds the wear indicator line.

* Keep grease or oil off the brake disk to avoid brake failure.



<Front Brake>



<Rear Brake>

BRAKE FLUID

Turn the steering handlebar upright and check if both brake fluid levels is at the upper limit. If the brake fluid is insufficient, fill to the upper limit.

Specified Brake Fluid: DOT-4

* The brake fluid level will decrease if the brake pads are worn.



3. INSPECTION/ADJUSTMENT

CLUTCH SHOE WEAR

Start engine and check the clutch operation by increasing the engine speed gradually.

If the motorcycle tends to creep or the engine stop, check the clutch shoes for wear and replace if necessary.



SUSPENSION

FRONT

Check the action of the front shock absorbers by compressing them several times.

Check the entire shock absorber assembly for oil leaks, looseness or damage.

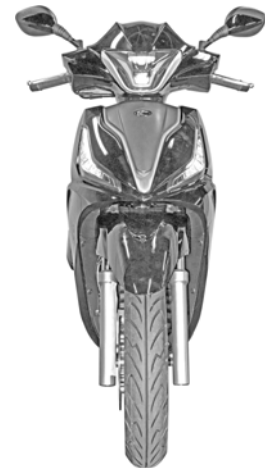

REAR

Each shock absorber(4) on your scooter has 5 spring preload adjustment positions for different load or riding conditions.

Use a pin spanner(5) to adjust the rear shock spring preload. Position 1 is for light loads and smooth road conditions. Position 3 to 5 increase spring preload for a stiffer rear suspension and can be used when the scooter is heavily loaded.

Be certain to adjust both shock absorbers to the same spring preload positions.

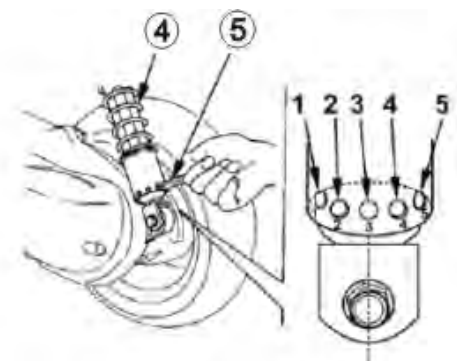

3. INSPECTION/ADJUSTMENT

NUTS/BOLTS/FASTENERS

Check all important chassis nuts and bolts for looseness.

Tighten them to their specified torque values if any looseness is found.

WHEELS/TIRES

Check the tires for cuts, imbedded nails or other damages.

Check the tire pressure.

- * • Tire pressure should be checked when tires are cold.

Tire Pressure

	1 Rider	1 Rider (with passenger)
Front	1.75 kg/cm ²	2.00 kg/cm ²
Rear	1.75 kg/cm ²	2.25 kg/cm ²

Tire Size:

Front 110/70-16
Rear 140/70-16

Check the front axle nut for looseness.

Check the rear axle nut for looseness.

If the axle nuts are loose, tighten them to the specified torques.

Torque:

Front axle nut 20 N-m
Rear axle nut 120 N-m

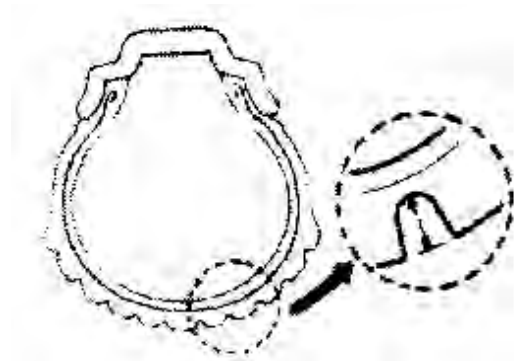

Front Axle Nut

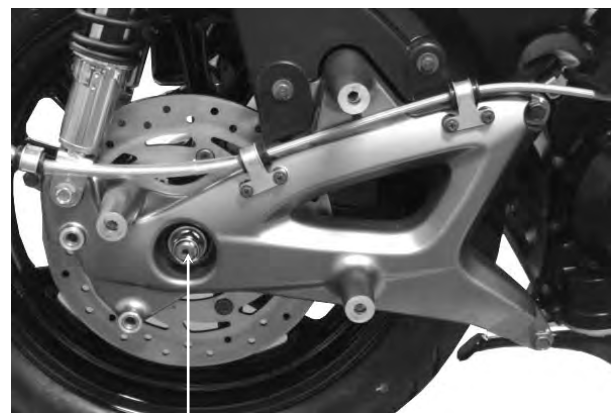

Rear Axle Nut

STEERING HANDLEBAR

Raise the front wheel off the ground and check that the steering handlebar rotates freely.

If the handlebar moves unevenly, binds, or has vertical movement, adjust the steering head bearing.

3. INSPECTION/ADJUSTMENT

SIDE STAND

Your scooter's side stand is not only necessary when you park, but it contains an important safety feature. This feature cuts-off the ignition if you try to ride the scooter when the side stand is down. Perform the following side stand inspection.

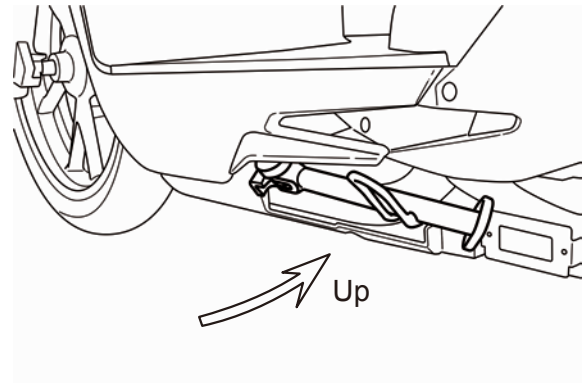

INTERLOCK FUNCTION CHECK

Check the side stand ignition cut-off system,

1. Place the scooter on its center stand.
2. Put the side stand up and start the engine.
3. Lower the side stand. The engine should stop as you put the side stand down.

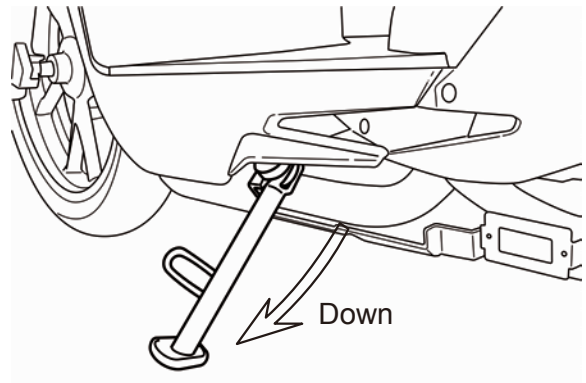

* If the side stand system does not operate as described, see your KYMCO dealer for service.

4. LUBRICATION SYSTEM

SERVICE INFORMATION	4-1	OIL FILTER REPLACEMENT	4-3
TROUBLESHOOTING	4-1	OIL PUMP	4-4
ENGINE OIL/OIL FILTER	4-2		

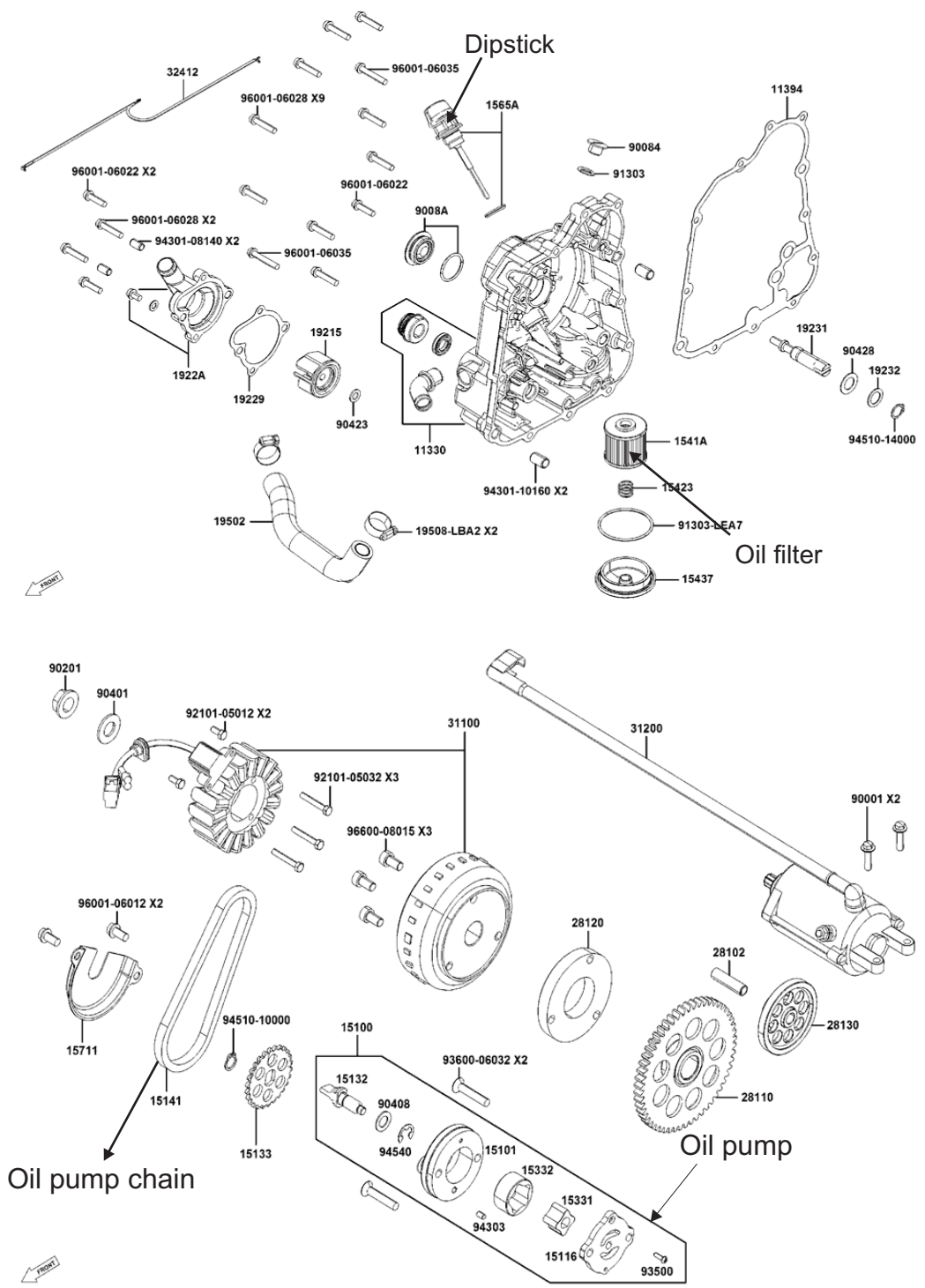

4

4. LUBRICATION SYSTEM

SERVICE INFORMATION

GENERAL INSTRUCTIONS

The maintenance of lubrication system can be performed with the engine installed in the frame.

Use care when removing and installing the oil pump not to allow dust and foreign matters to enter the engine and oil line.

Do not attempt to disassemble the oil pump. The oil pump must be replaced as a set when it reaches its service limit.

After the oil pump is installed, check each part for oil leaks.

TROUBLESHOOTING

Oil level too low

1. Natural oil consumption
2. Oil leaks
3. Worn or poorly installed piston rings
4. Worn valve guide or seal

Poor lubrication pressure

1. Oil level too low
2. Clogged oil filter or oil passages
3. No use the specified oil

4. LUBRICATION SYSTEM

ENGINE OIL/OIL FILTER

OIL LEVEL

* Place the motorcycle upright on level ground for engine oil level check. Run the engine for 2~3 minutes and check the oil level after the engine is stopped for 2~3 minutes.

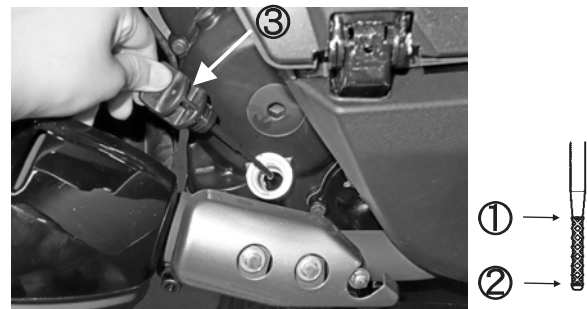

Check the engine oil level each day before riding your scooter. The level must be maintained between the upper ① and lower level ② marks on the oil filler cap/dipstick ③.

OIL CHANGE

* The engine oil will drain more easily while the engine is warm.

Remove the oil filter screen cap located on the bottom of the engine to drain the engine oil thoroughly.

Clean the oil filter screen.
Install the oil filter screen and filter screen cap.
Fill the engine with recommended engine oil.



Oil Filter Screen

Engine oil recommendation

Use a fully synthetic quality 4-stroke engine oil to ensure longer service life of your scooter. Only use oils that have a SJ rating above per the API service classification.

Engine oil viscosity : SAE 5W-50

If these viscosities are not available, select an alternative engine oil according to the chart shown below.

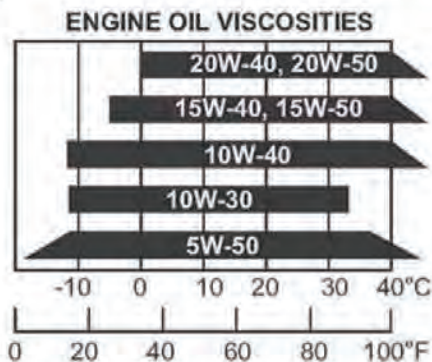

Engine oil capacity: 1.5 L

4. LUBRICATION SYSTEM

OIL FILTER REPLACEMENT

Remove the oil filler cap attaching the right-under crankcase cover.

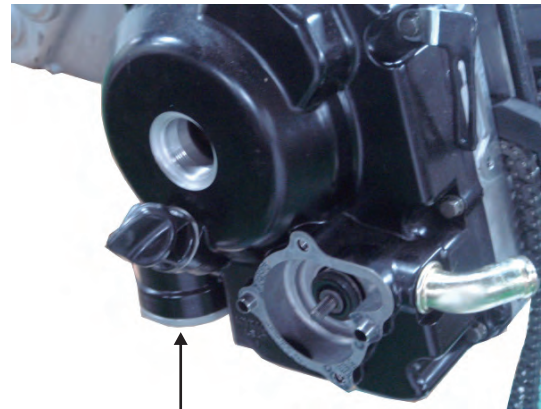

Oil Filter Cap

The spring will come out when the filter cap is removed.
Let the engine oil drain out.
Check that the O-ring is in good condition

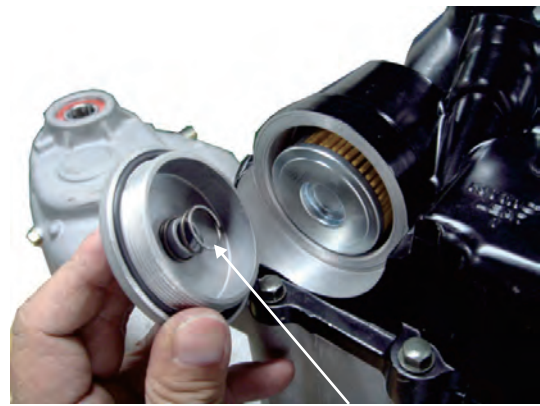

Spring

Install a new oil filter.

* Make sure the rubber seal on the oil filter facing the left crankcase



MESH FILTER REPLACEMENT

Drain the engine oil.
Remove the right crankcase cover.
Clean the mesh filter at every 10000km.
Check the mesh filter for clogging or damage and replace if necessary.
Install the mesh filter and a new gasket.

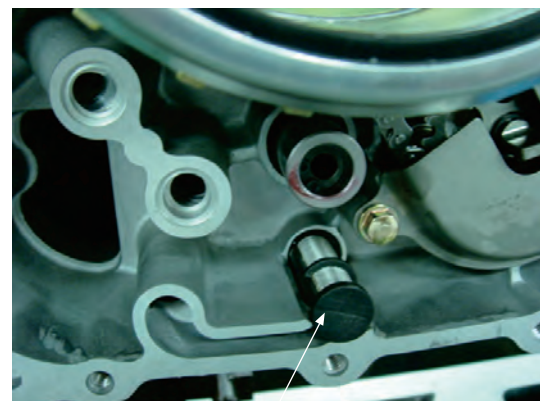

Mesh Filter

4. LUBRICATION SYSTEM

OIL PUMP

REMOVAL

Remove twelve bolts attaching the right crankcase cover.

Remove the A.C. generator flywheel with special tool.

Special

Flywheel puller E003
 Universal Holder E021

Remove the gasket and dowel pins.
 Remove the starter idle gear and starter clutch.

Remove the two bolts and oil separator cover.

Remove the oil pump driven gear clip to remove the oil pump driven gear and drive chain.

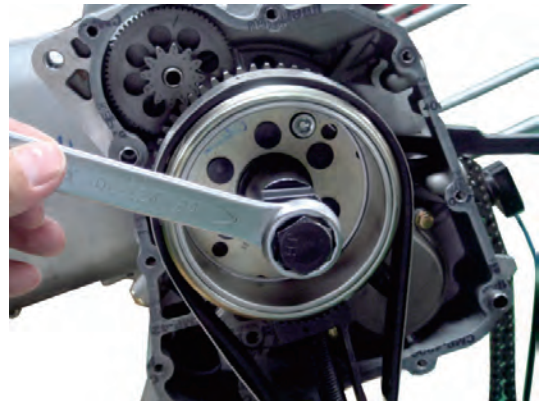

Starter idle gear

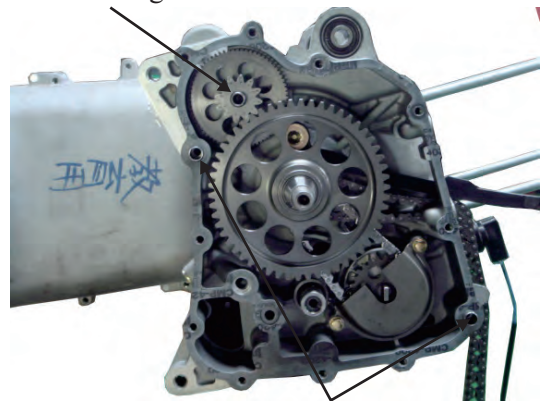

Dowel Pins

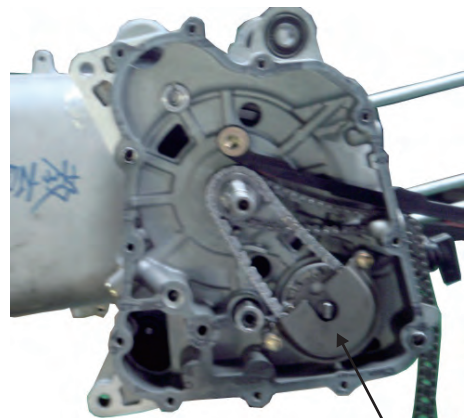

Oil separator cover

Oil pump drive chain

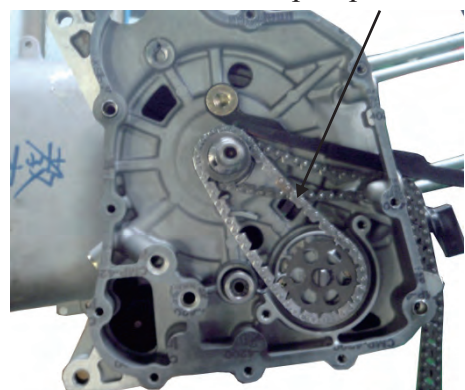

4. LUBRICATION SYSTEM

Remove two oil pump mounting bolts and the oil pump.

INSTALLATION

Install the oil pump into the crankcase.

* Install the oil pump with the arrow on the pump body facing up and fill the oil pump with engine oil before installation.

After the oil pump is installed, tighten the two mounting bolts.

Install the pump driven gear and drive chain by aligning the pump driven gear with the cutout in the pump shaft.
Install and tighten the pump driven gear bolts.

Install the oil separator cover and tighten the bolts.

Install the starter idle gear and starter clutch.
Install the gasket and dowel pins.

Install the right crankcase cover and tighten the twelve bolts.

Torque: 1.2 kg-m

* Diagonally tighten the bolts in 2~3 times.

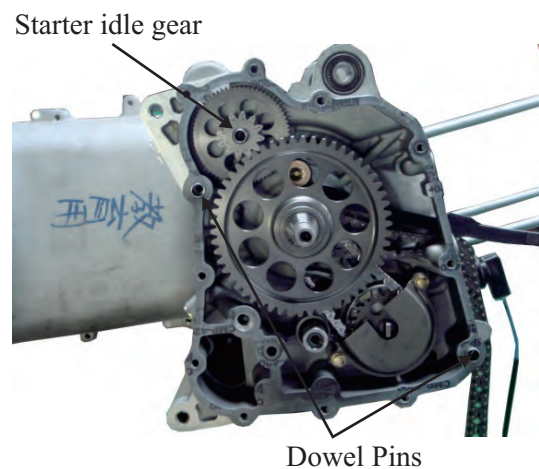
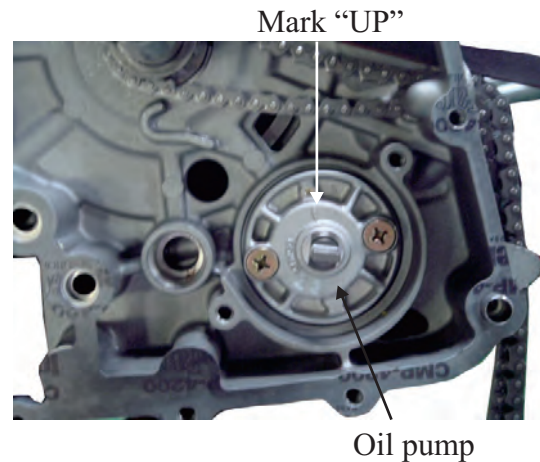

5.ENGINE REMOVAL/INSTALLATION

SERVICE INFORMATION

GENERAL INSTRUCTIONS

- A floor jack or other adjustable support is required to support and maneuver the engine. Be careful not to damage the scooter body, cables and wires during engine removal.
- Use shop towels to protect the scooter body during engine removal.
- Drain the coolant before removing the engine.
- After the engine is installed, fill the cooling system with coolant and be sure to bleed air from the water jacket. Start the engine to check for coolant leaks.
- Before removing the engine, the rear brake caliper must be removed first. Be careful not to bend or twist the brake fluid tube.

SPECIFICATIONS

Engine oil capacity:

At disassembly: 1.5 L

At change: 1.3 L

Coolant capacity:

Radiator:	766 cc
Hose with cool coolant:	169 cc
Hose with hot coolant:	194 cc
Reserve tank:	590 cc
Total capacity:	1719 cc

TORQUE VALUES

90304-GHE8-0040	Engine hanger (Engine side)	5.0 kgf-m (50 N-m)
90305-LBD4-9000	Engine hanger (Frame side)	6.5 kgf-m (65 N-m)
95801-10060	Rear fork mount bolts	3.5 kgf-m (35 N-m)
90305-KFW6-9120-M1	Rear axle nut	12.0 kgf-m (120 N-m)
95801-10035-00	Rear cushion lower/upper mount bolts	4.0 kgf-m (40 N-m)

5.ENGINE REMOVAL/INSTALLATION

ENGINE REMOVAL/INSTALLATION

REMOVAL

Remove the air cleaner

Disconnect the connector including of ISC, Throttle body, TPS, WTS, MAP sensor and injector.

Disconnect the O2 sensor connector.

Disconnect the throttle cables.

Disconnect the Regulator/Rectifier connector.

Disconnect the starter relay wire from starter motor.

Disconnect the fuel hose from fuel injector.

Throttle Body MAP Air Cleaner Connector

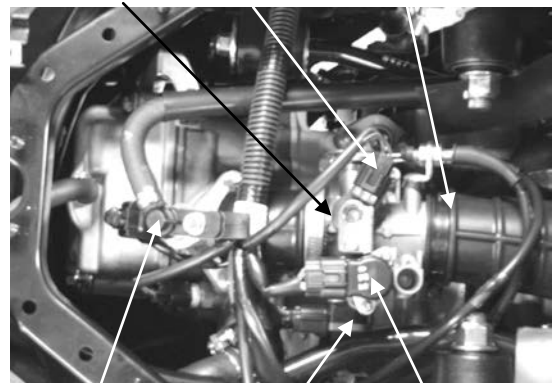

Injector TPS ISC



Regulator/Rectifier

Starter Relay



Disconnect the input water hose.

Disconnect the air bleed hose.

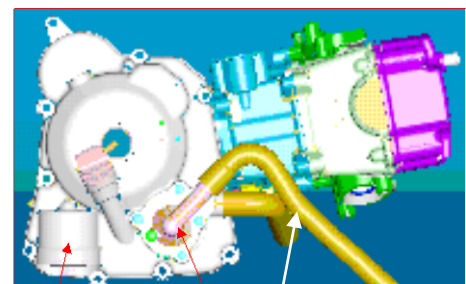

Water hose

Oil filter

Water pump

5. ENGINE REMOVAL/INSTALLATION

Remove the muffler.

Remove the rear fork mounting bolts (1) attaching to the crankcase.

Torque: 3.5 kgf-m (35 N-m)

Remove the rear axle nut (2).

Torque: 12.0 kgf-m (120 N-m)

Remove two bolts (3) attaching to rear brake hose clamps.

Torque: 3.2 kgf-m (32 N-m)

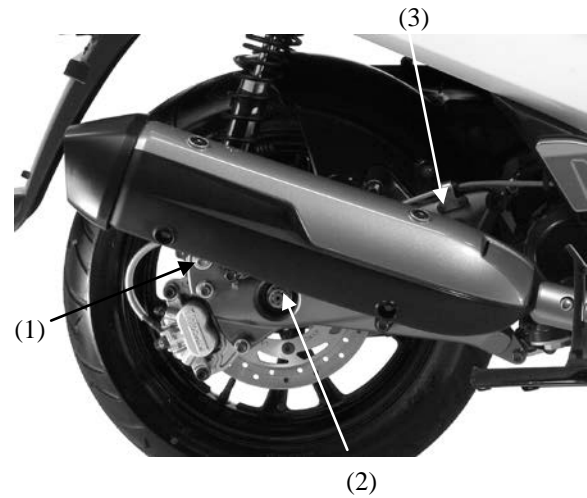

Disconnect the Regulator/Rectifier connector (5).

Disconnect the ignition pulse generator connector.

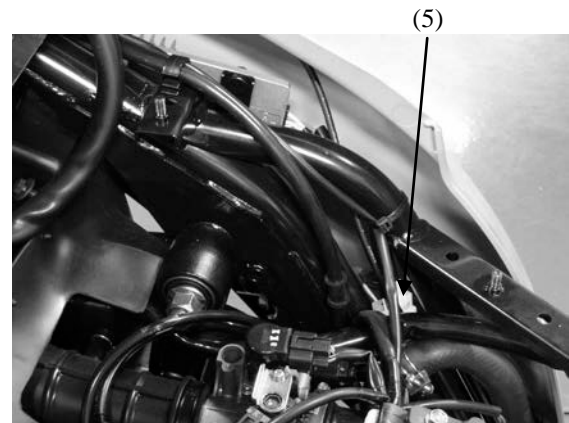

Release the rubber cap and remove the terminal screw (6) to disconnect the start motor cable from the start motor.

Remove the bolt and engine ground cable.

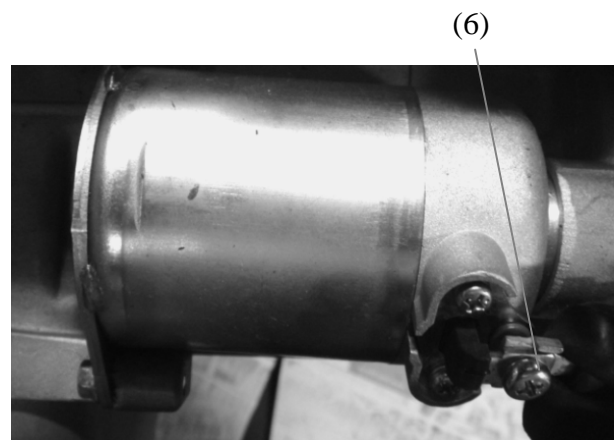

5. ENGINE REMOVAL/INSTALLATION

Remove the spark plug cap.

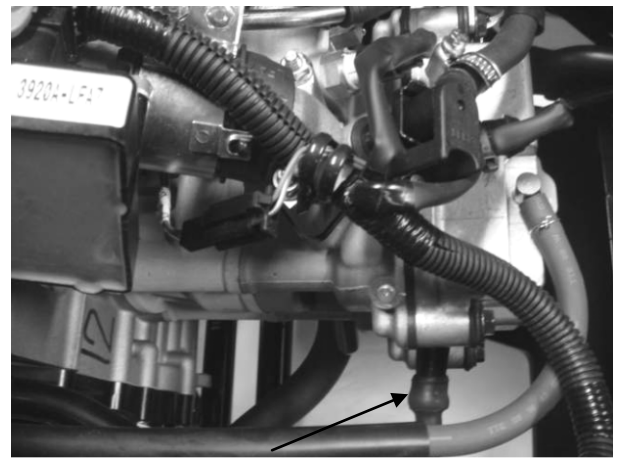

Spark Plug Cap

Disconnect the lower radiator hose from lower radiator pipe.

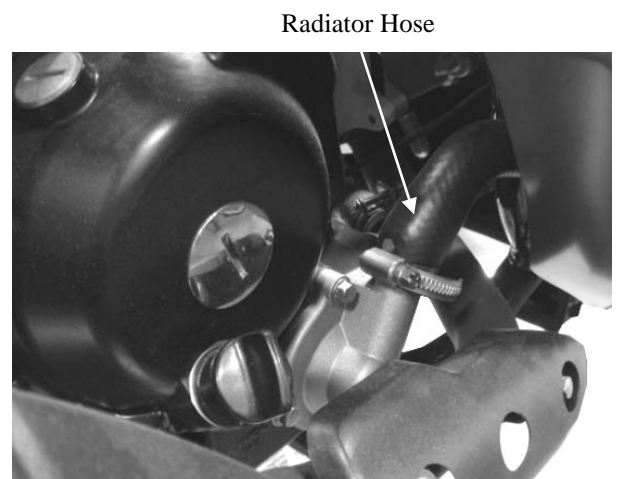

Radiator Hose

Remove the right and left rear cushion lower mount bolts.

Torque: 4.0 kgf-m (40N-m)



Mount Bolt

5. ENGINE REMOVAL/INSTALLATION

Remove the engine mount nut and pull it out.
Remove the engine from the frame.

* At removing the engine, be careful not to catch your hand or finger between the engine hanger and crankcase.

Torque: 6.5 kgf-m (65 N-m)

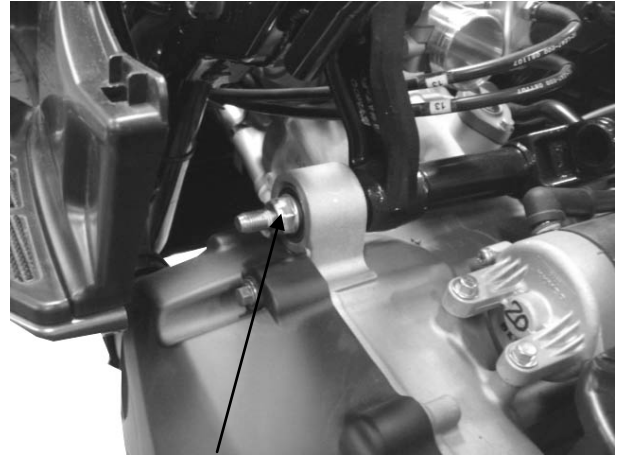

Mount Nut

INSTALLATION

Installation is in the reverse order of removal.

After installation, inspect and adjust the following:

- Throttle grip free play
- Fill the cooling system with coolant and start the engine to bleed air from the system.
- API/ABV Reset (Refer to chapter14, page 17)

5. ENGINE REMOVAL/INSTALLATION

ENGINE HANGER

REMOVAL

Remove the engine mount nut and pull it out.

* Be careful to put the engine down.

Remove the left/right engine hanger mount bolt.

Remove the engine from frame.

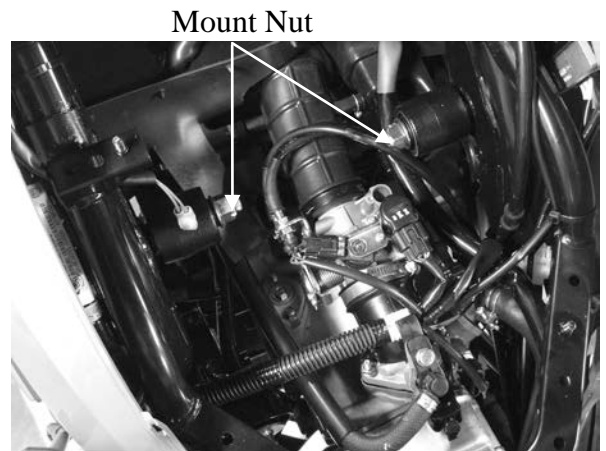

INSTALLATION

Installation is in the reverse order of removal.

Tighten the engine hanger mount bolts to the specified torque.

Torque: 6.5 kgf-m (65 N-m)

6. CYLINDER HEAD/VALVES

6

CYLINDER HEAD/VALVES

SCHEMATIC DRAWING	6- 1
SERVICE INFORMATION	6- 2
TROUBLESHOOTING	6- 3
CYLINDER HEAD COVER REMOVAL	6- 4
CAMSHAFT REMOVAL	6- 4
CYLINDER HEAD REMOVAL	6- 6
CYLINDER HEAD DISASSEMBLY	6- 7
CYLINDER HEAD ASSEMBLY	6- 8
CYLINDER HEAD INSTALLATION	6- 9
CAMSHAFT INSTALLATION	6- 9
CYLINDER HEAD COVER INSTALLATION	6-11

6. CYLINDER HEAD/VALVES

SCHEMATIC DRAWING

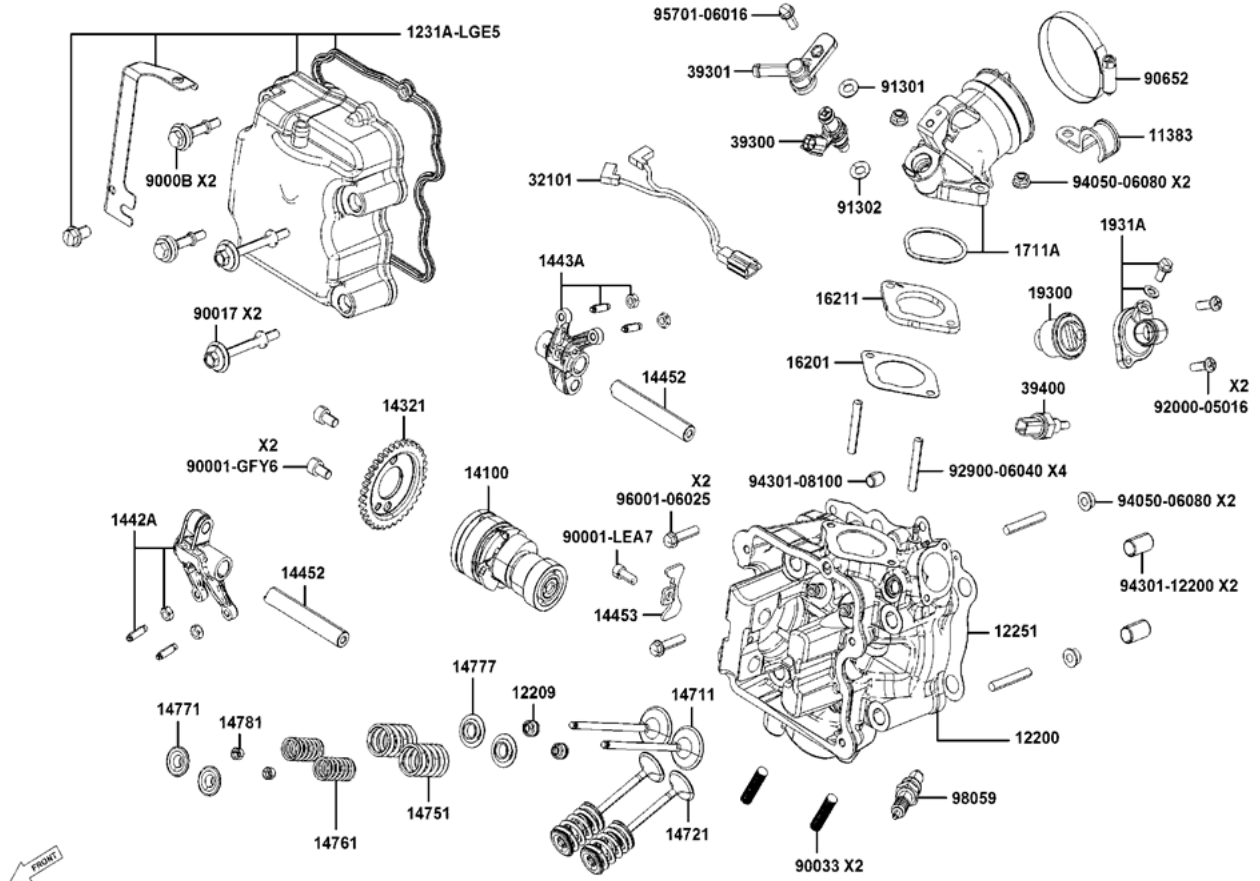

6. CYLINDER HEAD/VALVES

SERVICE INFORMATION

GENERAL INSTRUCTIONS

- The cylinder head can be serviced with the engine installed in the frame. Coolant in the radiator and water hoses must be drained.
- When assembling, apply molybdenum disulfide grease or engine oil to the valve guide movable parts and valve arm sliding surfaces for initial lubrication.
- The valve rocker arms are lubricated by engine oil through the engine oil passages. Clean and unclog the oil passages before assembling the cylinder head.
- After disassembly, clean the removed parts and dry them with compressed air before inspection.
- After removal, mark and arrange the removed parts in order. When assembling, install them in the reverse order of removal.

SPECIFICATIONS		Standard (mm)
Item		
Valve clearance (cold)	IN	0.10
	EX	0.10
Cylinder head compression pressure		16 kg/cm ²
Camshaft cam height	IN	34.2987
	EX	34.1721
Valve rocker arm I.D.	IN	10.00 ~ 10.015
	EX	10.00 ~ 10.015
Valve rocker arm shaft O.D.	IN	9.972 ~ 9.987
	EX	9.972 ~ 9.987
Valve seat width	IN	1.2
	EX	1.2
Valve stem O.D.	IN	4.990 ~ 4.975
	EX	4.970 ~ 4.955
Valve guide I.D.	IN	5.00 ~ 5.012
	EX	5.00 ~ 5.012
Valve stem-to-guide clearance	IN	0.010 ~ 0.037
	EX	0.030 ~ 0.057

TORQUE VALUES

Item	Qty	Thread size (mm)	Torque (kgf-m)	Remarks
Cylinder head stud bolt:				
1.Stud bolt (Inlet pipe side)	2	6	0.7~1.1	Double end bolt
2.Stud bolt (EX pipe side)	2	8	0.7~1.1	Double end bolt
Bolt B stud 10*180	4	10	1.0~1.4	Apply oil to thread
Valve adjusting lock nut	4	5	0.7~1.1	Apply oil to thread
Cam sprocket bolt	2	6	1.0~1.4	

SPECIAL TOOL

Valve spring compressor

E063

6. CYLINDER HEAD/VALVES

TROUBLESHOOTING

- The poor cylinder head operation can be diagnosed by a compression test or by tracing engine top-end noises.

Poor performance at idle speed

- Compression too low

Compression too low

- Incorrect valve clearance adjustment
- Burned or bent valves
- Incorrect valve timing
- Broken valve spring
- Poor valve and seat contact
- Leaking cylinder head gasket
- Warped or cracked cylinder head
- Poorly installed spark plug

Compression too high

- Excessive carbon build-up in combustion chamber

White smoke from exhaust muffler

- Worn valve stem or valve guide
- Damaged valve stem oil seal

Abnormal noise

- Incorrect valve clearance adjustment
- Sticking valve or broken valve spring
- Damaged or worn camshaft
- Worn cam chain tensioner
- Worn camshaft and rocker arm

6. CYLINDER HEAD/VALVES

CYLINDER HEAD COVER REMOVAL

Remove the met-in box.
Remove the body cover and center cover.
Disconnect the breather hose to air cleaner.
Remove the cylinder head cover four bolts.
Remove the cylinder head cover.

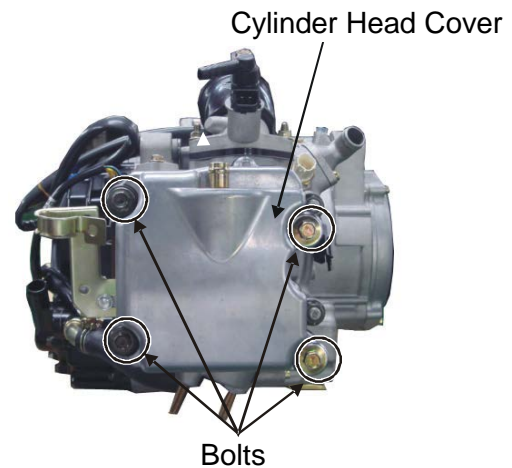

CAMSHAFT REMOVAL

Remove the injector and inlet pipe.
Remove two screws attaching the thermostat.

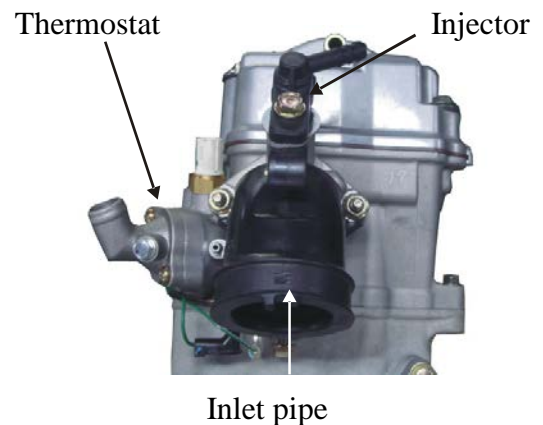

Turn the cam chain tensioner screw clockwise to tighten it.

Torque: 1.0 kgf-m (9.8 N-m)

Cam Chain Tensioner



6. CYLINDER HEAD/VALVES

Remove four nuts attaching to the cylinder head.

Remove two bolts attaching to the camshaft gear.

Remove the camshaft gear from the cam chain.

- * • Diagonally loosen the cylinder head cap nuts in 2 or 3 times.

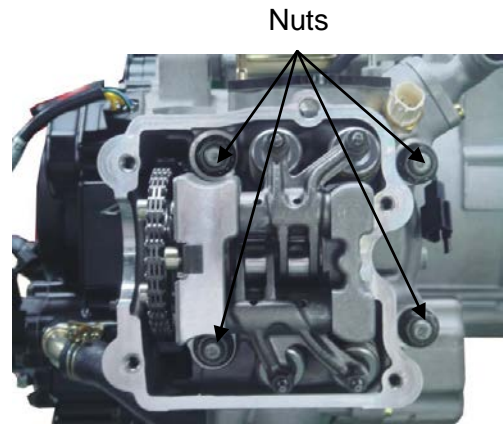

Remove the set plate located beside the rocker arm shaft.

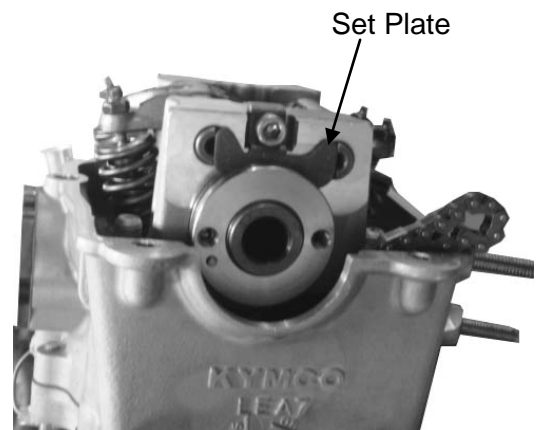
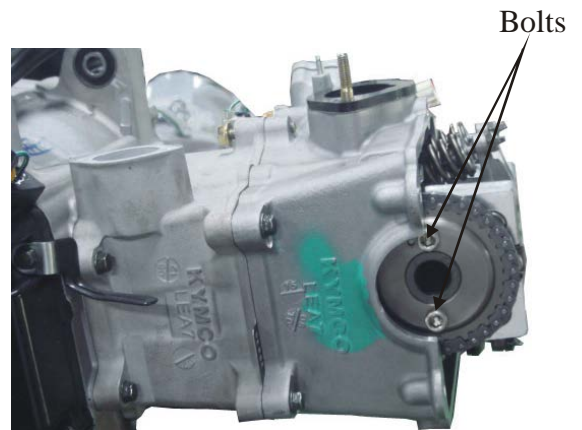

6. CYLINDER HEAD/VALVES

Remove the rocker arm with bolt as shown.

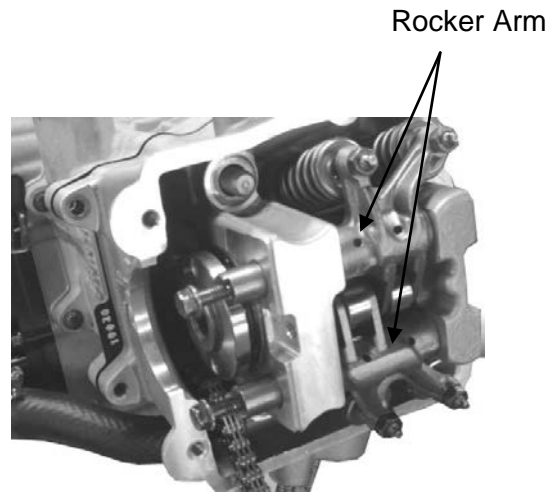

CAMSHAFT INSPECTION

Check each cam lobe for wear or damage. Check each camshaft bearing for play or damage. Replace the camshaft assembly with a new one if the bearings are noisy or have excessive play.

* If the surface of rocker arm is worn, check each cam lobe for wear or damage.

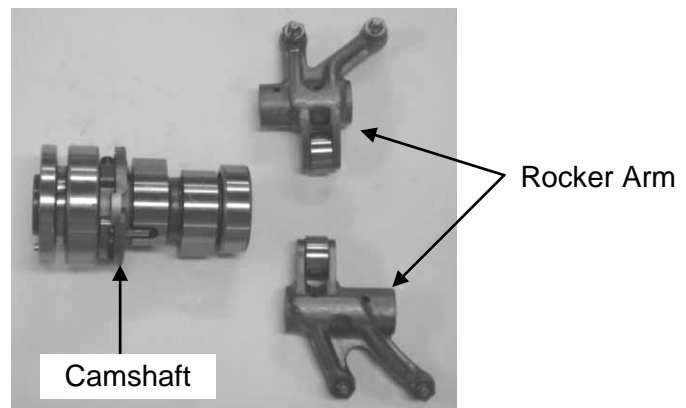

CYLINDER HEAD REMOVAL

Remove the muffler.
 Remove the throttle body.
 Drain the coolant from the radiator and water hose, then remove the thermostat water hose.
 Remove the camshaft.
 Remove the Temp/Map Sensor and intake manifold.
 Remove the bolt attaching the thermostat housing and the thermostat housing.
 Remove the cylinder head.

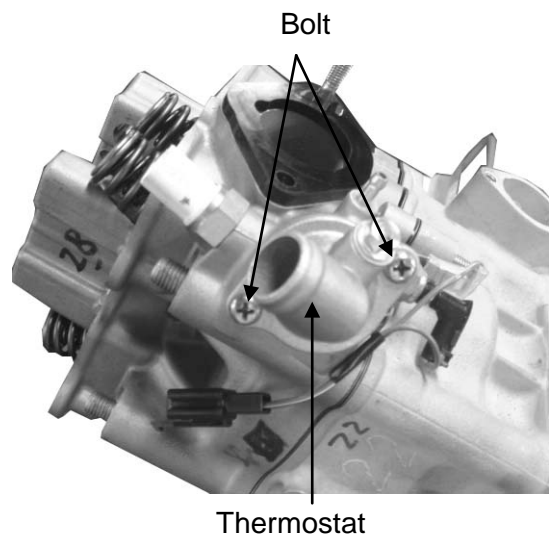

6. CYLINDER HEAD/VALVES

Remove two nuts attaching to the upper/lower side of cylinder head.
 Remove two bolts attaching to the cylinder head.
 Remove the cylinder head.

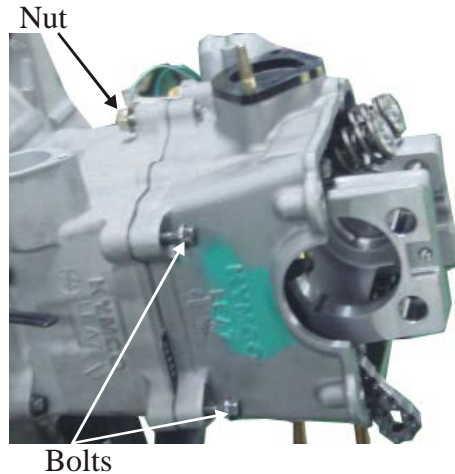

Remove the dowel pins and cylinder head gasket.
 Remove the cam chain guide.
 Remove all gasket material from the cylinder head mating surface.

* Be careful not to drop any gasket material into the engine.

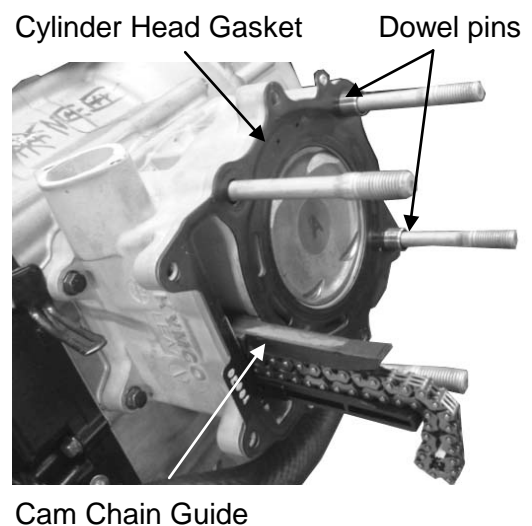

CYLINDER HEAD DISASSEMBLY

Remove the valve spring cotters, retainers, springs, spring seats and valve stem seals using a valve spring compressor.

*

- Be sure to compress the valve springs with a valve spring compressor.
- Mark all disassembled parts to ensure correct reassembly.

Special

Valve spring compressor E040

Remove carbon deposits from the exhaust port and combustion chamber.

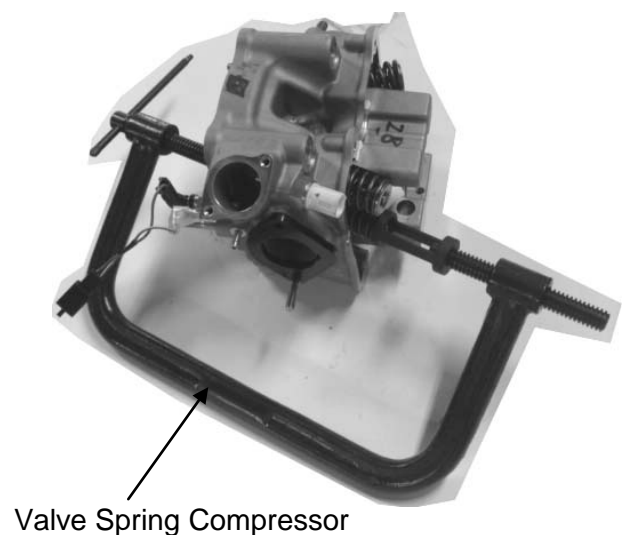

6. CYLINDER HEAD/VALVES

VALVE STEM INSPECTION

Inspect each valve for bending, burning, or abnormal stem wear.

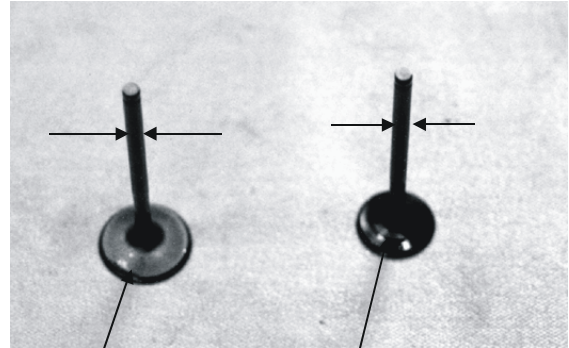

Intake valve

Exhaust valve

Remove carbon deposits from the combustion chamber.

Clean off any gasket remnants from the cylinder head contact surface.

* Be careful not to damage the cylinder head mating surface.

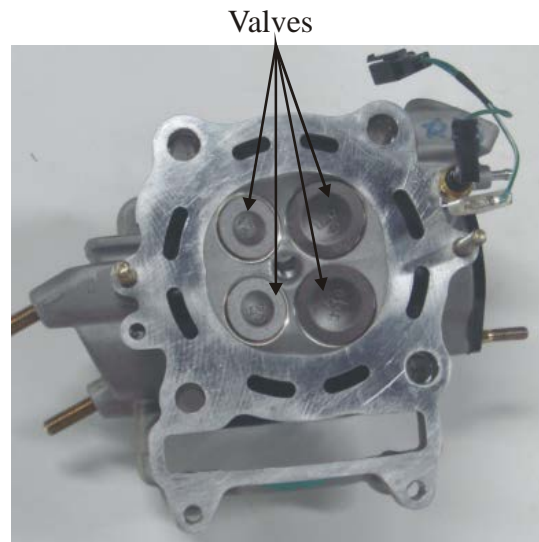

CYLINDER HEAD ASSEMBLY

Install the valve spring seats and stem seals. Lubricate each valve stem with engine oil and insert the valves into the valve guides. Be sure to install new valve stem seals. Install the valve spring.

Special

Valve spring compressor E040

- *
- Tap the valve stems gently with a plastic hammer for 2 ~ 3 times to firmly seat the cotters.
 - Be careful not to damage the valves.



6. CYLINDER HEAD/VALVES

CYLINDER HEAD INSTALLATION

Install the dowel pins and a new cylinder head gasket.

Install the cam chain guide.

- * • Clean the intake valve rocker arm shaft off any grease before installation.

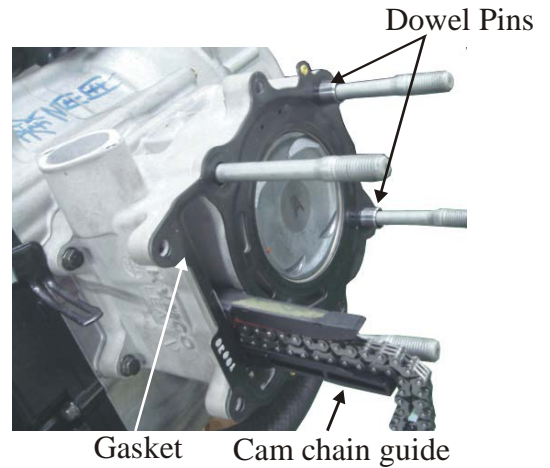

Install the cylinder head.
Install the camshaft.

Install the intake valve rocker arm and the rocker arm shafts.

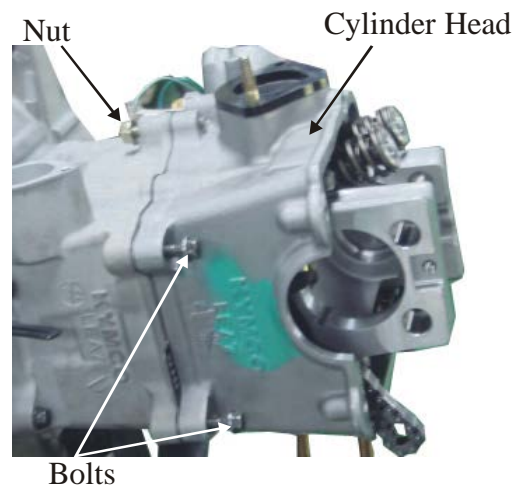

CAMSHAFT INSTALLATION

Install the set plate to prevent the rocker arm shaft from pull out.

Torque: 1.2 kgf-m (8.9 N-m)

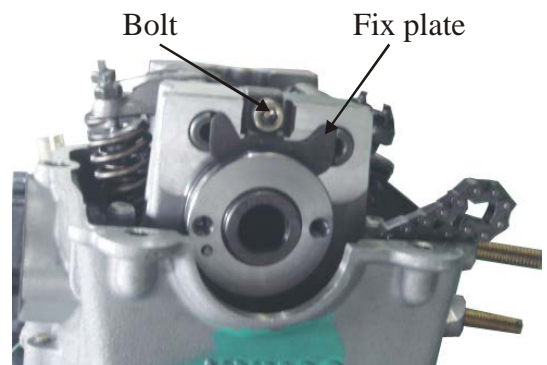

6. CYLINDER HEAD/VALVES

Tighten the four cylinder head nuts and the four bolts between the cylinder head and cylinder.

Torque:

Cylinder head nuts: 3.6 kgf-m (35.3 N-m)

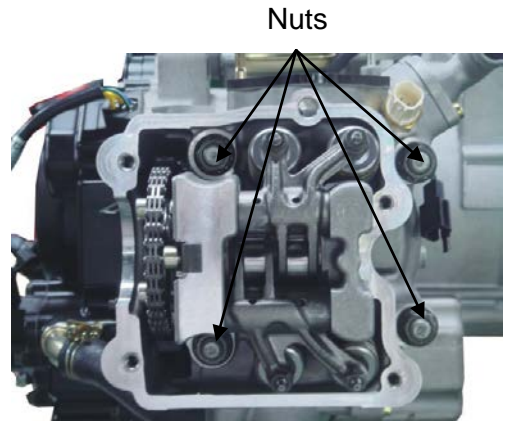

Turn the A.C. generator flywheel so that the "T" mark on the flywheel aligns with the index mark on the right crankcase cover. Keep the round hole on the camshaft gear facing up and align two bolts on the camshaft gear with the cylinder head surface (Position the intake and exhaust cam lobes down.) and install the cam chain over the camshaft gear.

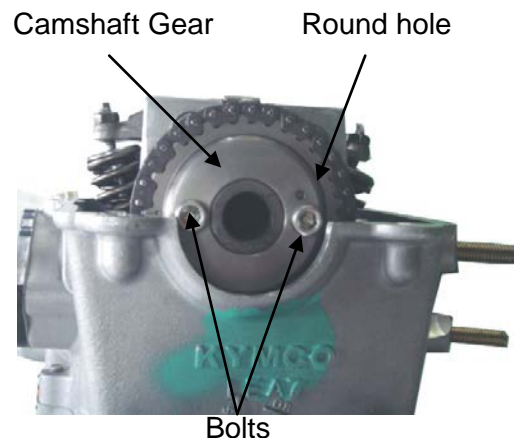

- *
- Apply engine oil to the threads of the cylinder head cap nuts.
 - Diagonally tighten the cylinder head cap nuts in 2~3 times.
 - First tighten the cylinder head cap nuts and then tighten the bolts between the cylinder and cylinder head to avoid cracks.

Install the thermostat bolt.

Torque: 1.2 kgf-m (11.8 N-m)

Turn the cam chain tension screw counter-clockwise to release it.

6. CYLINDER HEAD/VALVES

CYLINDER HEAD COVER INSTALLATION

Adjust the valve clearance.
Install a new cylinder head cover O-ring and install the cylinder head cover.

* Be sure to install the O-ring into the groove properly.

Install the inlet pipe.
Install the injector.
Install and tighten the cylinder head cover bolts.

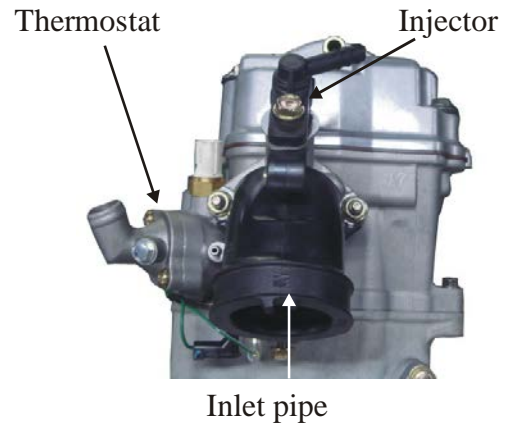

7. CYLINDER/PISTON



CYLINDER/PISTON



SCHEMATIC DRAWING	7-1
SERVICE INFORMATION	7-2
TROUBLESHOOTING	7-2
CYLINDER REMOVAL	7-3
PISTON REMOVAL	7-3
PISTON INSTALLATION	7-7
CYLINDER INSTALLATION	7-7

7. CYLINDER/PISTON

SCHEMATIC DRAWING

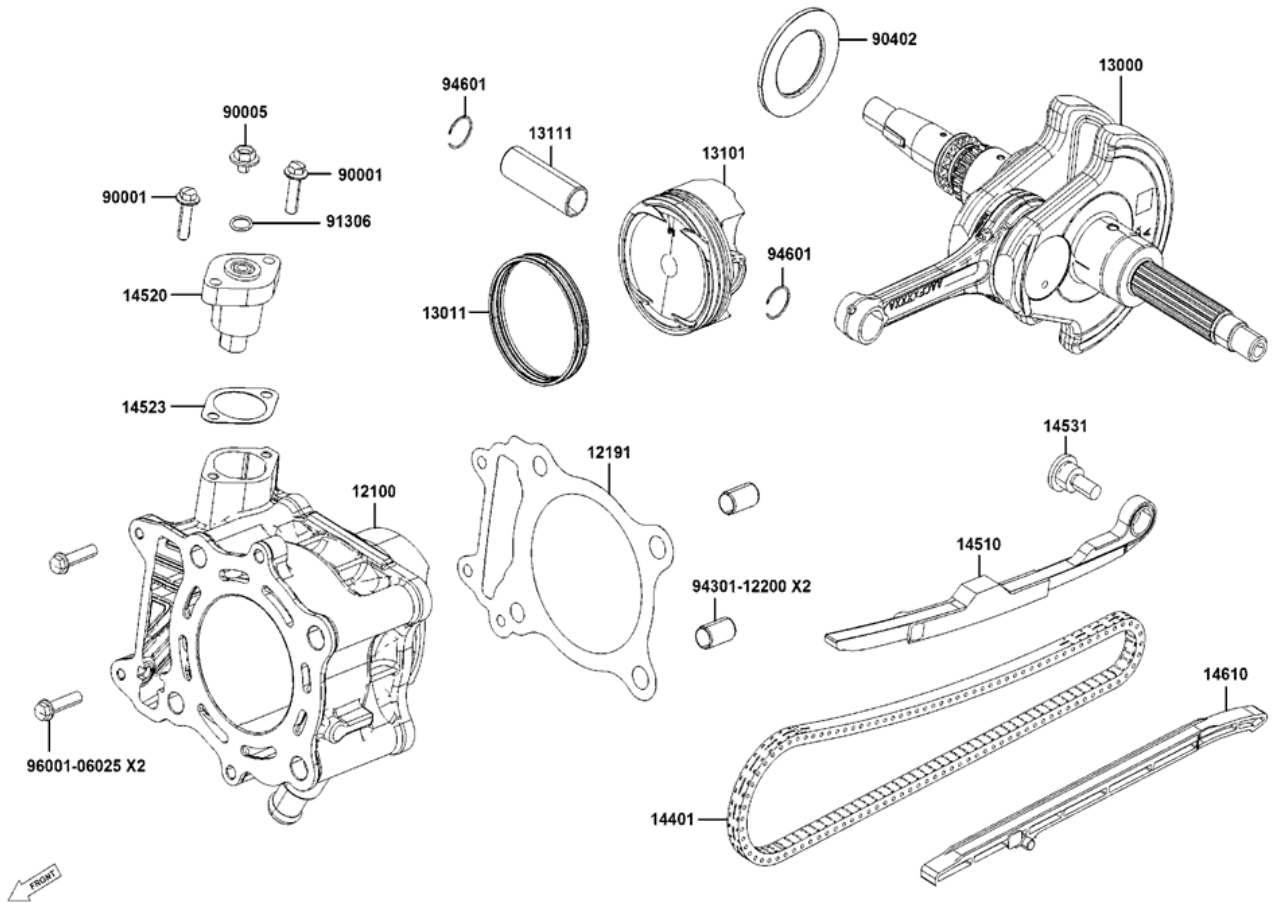

7. CYLINDER/PISTON

SERVICE INFORMATION

GENERAL INSTRUCTIONS

- The cylinder and piston can be serviced with the engine installed in the frame.
- When installing the cylinder, use a new cylinder gasket and make sure that the dowel pins are correctly installed.
- After disassembly, clean the removed parts and dry them with compressed air before inspection.

SPECIFICATIONS

Item		Standard (mm)	Service Limit (mm)	
Cylinder	I.D.	72.705~72.715	72.80	
Piston, piston ring	Ring-to-groove clearance	top	0.015~0.055	
		Second	0.015~0.055	
	Ring end gap	top	0.10~0.25	
		Second	0.10~0.25	
		Oil side rail	0.2~0.7	
	Piston O.D.		72.67~72.69	72.6
	Piston O.D. measuring position		9mm from bottom of skirt	
	Piston-to-cylinder clearance		0.010~0.040	0.1
Piston pin hole I.D.		15.002~15.008	15.04	
Piston pin O.D		14.994~15.000	16.96	
Piston-to-piston pin clearance		0.002~0.014	0.02	
Connecting rod small end I.D. bore		15.016~15.034	15.06	

TROUBLESHOOTING

- When hard starting or poor performance at low speed occurs, check the crankcase breather for white smoke. If white smoke is found, it means that the piston rings are worn, stuck or broken.

Compression too low or uneven compression

- Worn or damaged cylinder and piston rings
- Worn, stuck or broken piston rings

Excessive smoke from exhaust muffler

- Worn or damaged piston rings
- Worn or damaged cylinder and piston

Compression too high

- Excessive carbon build-up in combustion chamber or on piston head

Abnormal noisy piston

- Worn cylinder, piston and piston rings
- Worn piston pin hole and piston pin
- Incorrectly installed piston

7. CYLINDER/PISTON

CYLINDER REMOVAL

Remove the cylinder head.
Remove the cam chain guide.
Remove the cylinder.

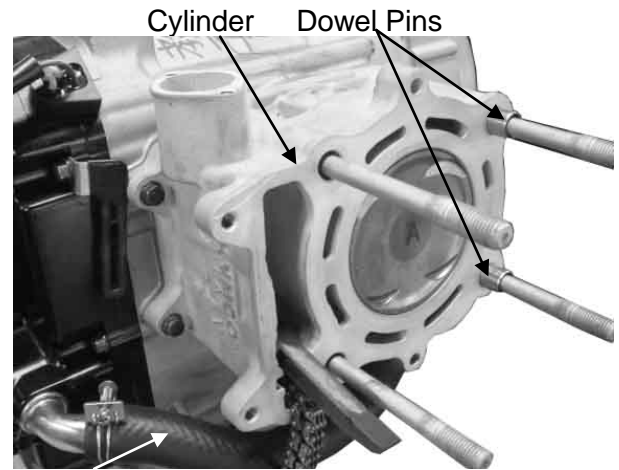

Water Hose

Remove the cylinder gasket and dowel pins.
Clean any gasket material from the cylinder surface.

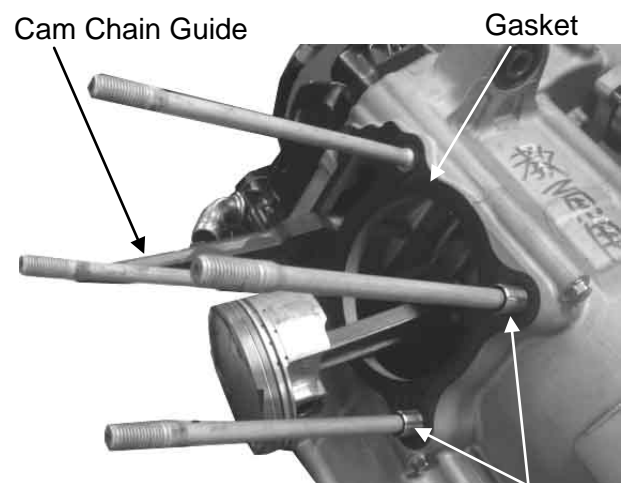

Dowel Pins

PISTON REMOVAL

Remove the piston pin clip.
Press the piston pin out of the piston.

* Place a clean towel in the crankcase to keep the piston pin clip from falling into the crankcase.

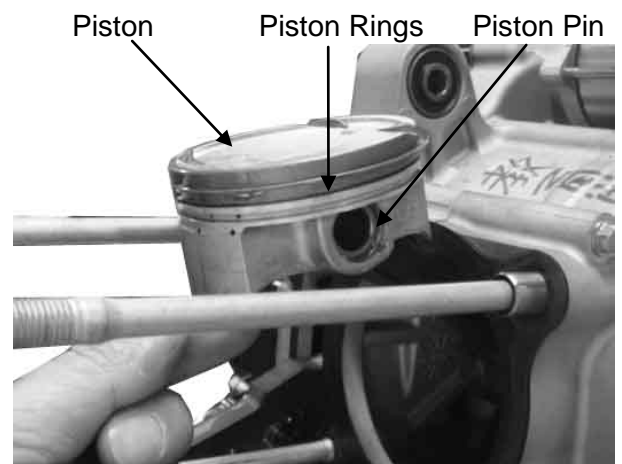

7. CYLINDER/PISTON

Inspect the piston, piston pin and piston rings.
Remove the piston rings.

* Take care not to damage or break the piston rings during removal.

Clean carbon deposits from the piston ring grooves.

Install the piston rings onto the piston and measure the piston ring-to-groove clearance.

Service Limits:

Top: 0.09 mm replace if over
2nd: 0.09 mm replace if over

Remove the piston rings and insert each piston ring into the cylinder bottom.

* Use the piston head to push each piston ring into the cylinder.

Measure the piston ring end gap.

Service Limit: 0.5mm replace if over

Measure the hole I.D. of piston pin

Service Limit: 15.04 mm replace if over

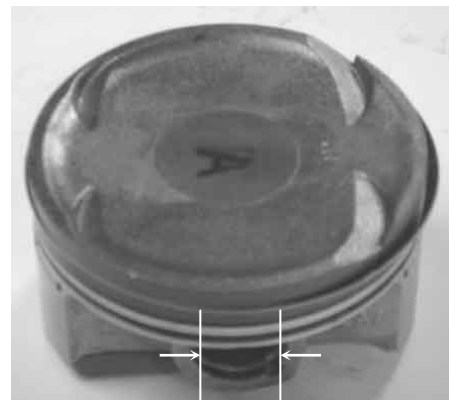

7. CYLINDER/PISTON

Measure the piston pin O.D.

Service Limit: 16.994 mm replace if below



Measure the piston O.D.

* Take measurement at 9mm from the bottom and 90° to the piston pin hole.

Service Limit: 72.70mm replace if below

Measure the piston-to-piston pin clearance.

Service Limit: 0.02mm replace if over



CYLINDER INSPECTION

Inspect the cylinder bore for wear or damage.

Measure the cylinder I.D. at three levels of top, middle and bottom at 90° to the piston pin (in both X and Y directions).

Service Limit:

72.70 mm repair or replace if over

Measure the cylinder-to-piston clearance.

Service Limit:

0.1 mm repair or replace if over

The true roundness is the difference between the values measured in X and Y directions. The cylindricity (difference between the values measured at the three levels) is subject to the maximum value calculated.

Service Limits:

True Roundness:

0.05mm repair or replace if over

Cylindricity: 0.05 mm repair or replace if over

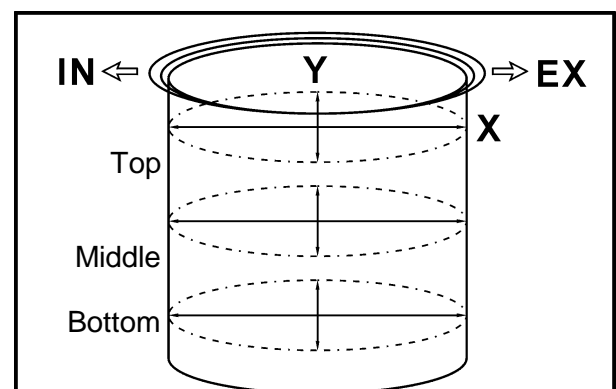

7. CYLINDER/PISTON

Measure the connecting rod small end I.D.

Service Limit: 15.06 mm replace if over

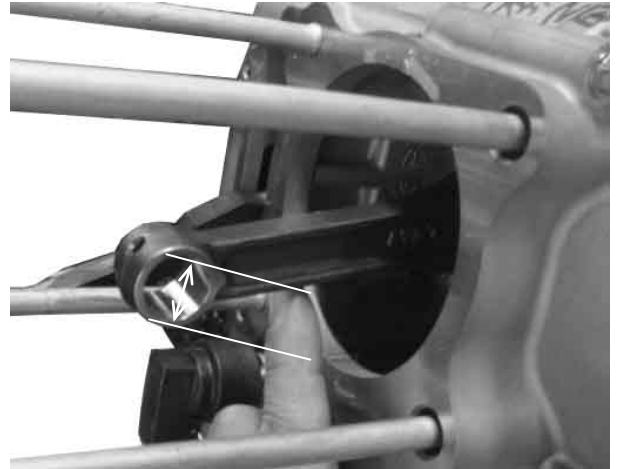

PISTON RING INSTALLATION

Install the piston rings onto the piston.
Apply engine oil to each piston ring.

- *
- Be careful not to damage the piston and piston rings during assembly.
 - All rings should be installed with the markings facing up.
 - After installing the rings, they should rotate freely without sticking.
 - Stagger the ring end gaps as the figure shown.

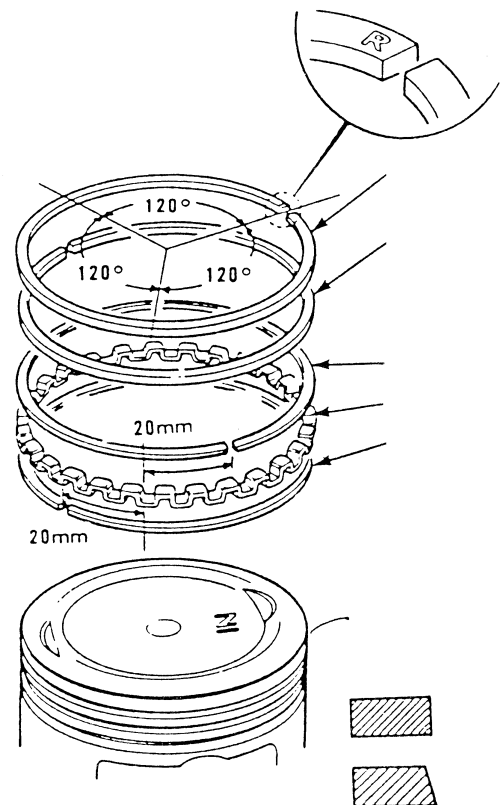

7. CYLINDER/PISTON

PISTON INSTALLATION

Remove any gasket material from the crankcase surface.

- * • Be careful not to drop foreign matters into the crankcase.

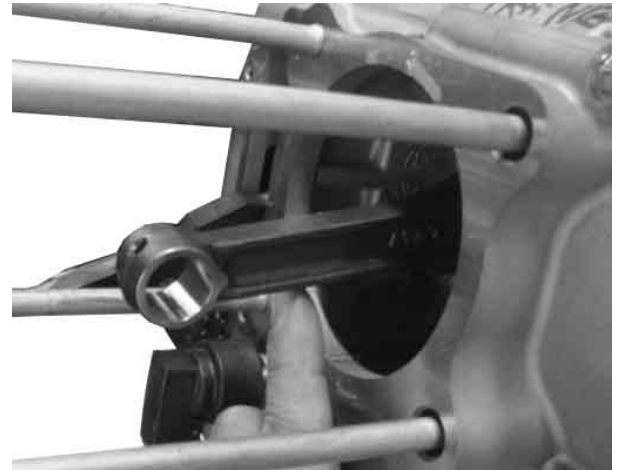

Install the piston, piston pin and a new piston pin clip.

- * • Position the piston "IN" mark on the intake valve side.
• Place a clean towel in the crankcase to keep the piston pin clip from falling into the crankcase.

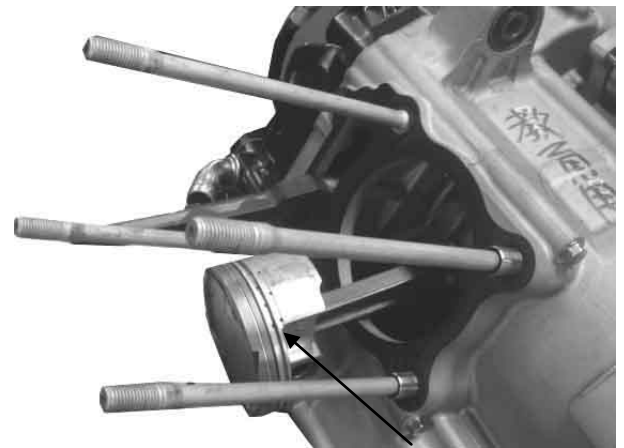

Piston

CYLINDER INSTALLATION

Install the dowel pins and a new cylinder gasket on the crankcase.

- * The piston must be changed in pair with cylinder.

2	B	$\phi 72.7 \begin{matrix} 0 \\ -0.010 \end{matrix}$	$\phi 72.7 \begin{matrix} +0.020 \\ +0.010 \end{matrix}$	0.010~0.030
1	A	$\phi 72.7 \begin{matrix} -0.010 \\ -0.020 \end{matrix}$	$\phi 72.7 \begin{matrix} +0.010 \\ 0 \end{matrix}$	0.010~0.030
NO	MARK	PISTON O.D.	CYLINDER BORE	CLEARANCE

7. CYLINDER/PISTON

Install the cam chain guide.

- * • Insert the tab on the cam chain guide into the cylinder groove.

Install the cylinder head gasket and dowel pins.

Connect the water hose to the cylinder.

Install the cylinder head.

Tighten the cylinder base bolt.

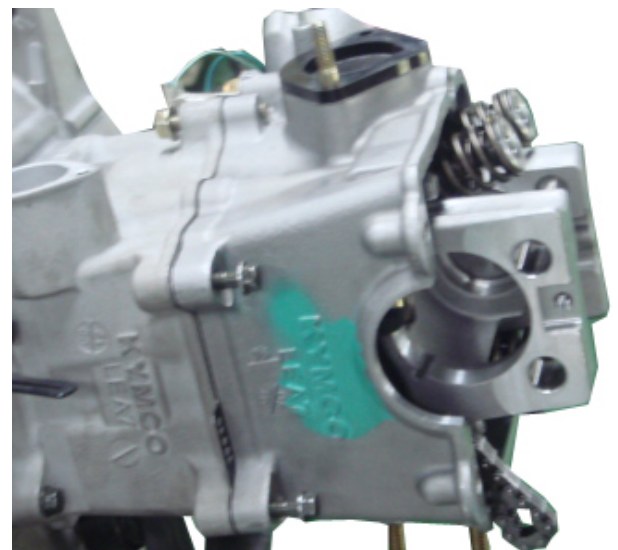
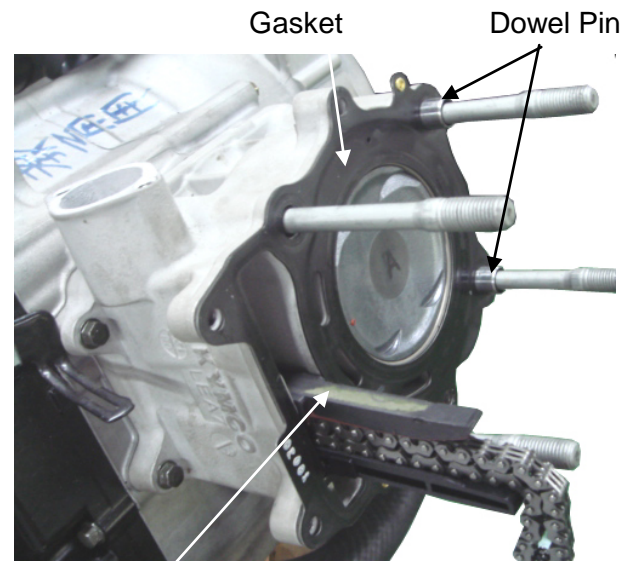

8. DRIVE AND DRIVEN PULLEYS/ V-BELT



People S 300 ABS

DRIVE AND DRIVEN PULLEYS/V-BELT

SCHEMATIC DRAWING	8- 1
SERVICE INFORMATION	8- 2
TROUBLESHOOTING	8- 2
LEFT CRANKCASE COVER	8- 3
DRIVE PULLEY.....	8- 3
CLUTCH OUTER/DRIVEN PULLEY/V-BELT	8- 3



8. DRIVE AND DRIVEN PULLEYS/ V-BELT



People S 300 ABS

SCHEMATIC DRAWING

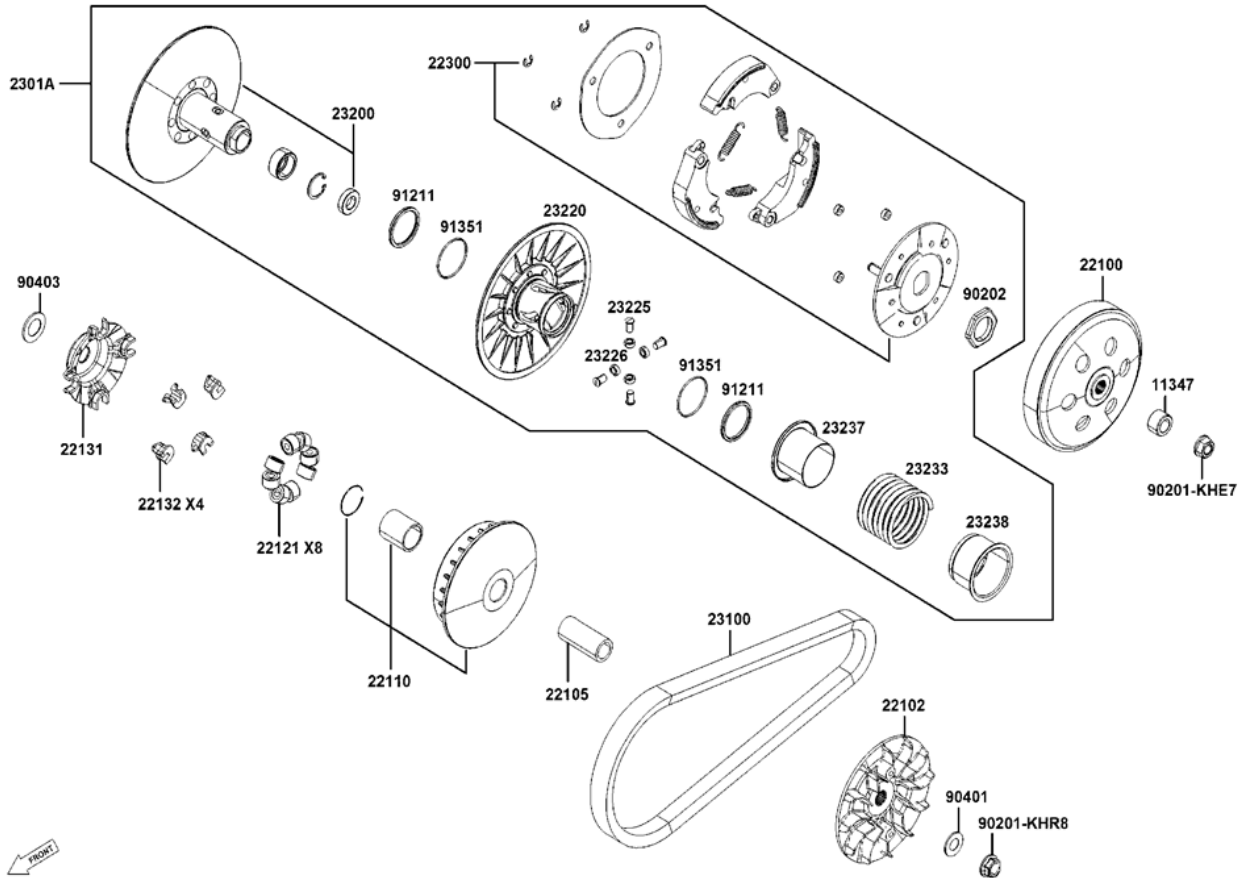

8. DRIVE AND DRIVEN PULLEYS/ V-BELT

SERVICE INFORMATION

GENERAL INSTRUCTIONS

- The drive pulley, clutch and driven pulley can be serviced with the engine installed.
- Avoid getting grease and oil on the drive belt and pulley faces. Remove any oil or grease from them to minimize the slipping of drive belt and drive pulley.

SPECIFICATIONS

Item	Standard (mm)	Service Limit (mm)
Clutch lining thickness	4.0	2.0
Clutch outer I.D.	152.1 ~ 152.2	152.2
Weight roller O.D	19.92 ~ 20.08	20

TORQUE VALUES

Drive face nut	9.5 kgf-m (93.1 N-m)	Apply oil
Clutch outer nut	5.5 kgf-m (54 N-m)	
Clutch drive plate nut	5.5 kgf-m (54 N-m)	

SPECIAL TOOLS

Universal holder	E017
Clutch spring compressor	E053
Fittings & Nut Wrench, 41mm	E028

TROUBLESHOOTING

Engine starts but motorcycle won't move

- Worn drive belt
- Broken ramp plate
- Worn or damaged clutch lining
- Broken driven face spring

Lack of power

- Worn drive belt
- Weak driven face spring
- Worn weight roller
- Faulty driven face

Engine stalls or motorcycle creeps

- Broken clutch weight spring

8. DRIVE AND DRIVEN PULLEYS/ V-BELT

LEFT CRANKCASE COVER

REMOVAL

Remove the met-in box and carrier.
Remove the body cover, center cover and rear fender A together.
Remove the protector cover of left crankcase cover.
Remove the bolts attaching to the left crankcase cover.
Remove the gasket and dowel pins.

INSPECTION

Check the bearing for wear or damage.
Replace the bearing with a new one if the bearing is noisy or have excessive play.

DRIVE PULLEY

DRIVE PULLEY FACE REMOVAL

Remove the left crankcase cover.
Hold the drive pulley using a universal holder and remove the drive face nut and washer.
Remove the drive pulley face.



Universal Holder E017

CLUTCH OUTER/DRIVEN PULLEY/V-BELT

REMOVAL

Remove the drive pulley face.
Hold the clutch outer with the universal holder and remove the clutch outer nut, bushing and washer.



Universal Holder E017

Remove the clutch outer, driven pulley and belt together.

Remove the drive belt from the movable drive face.

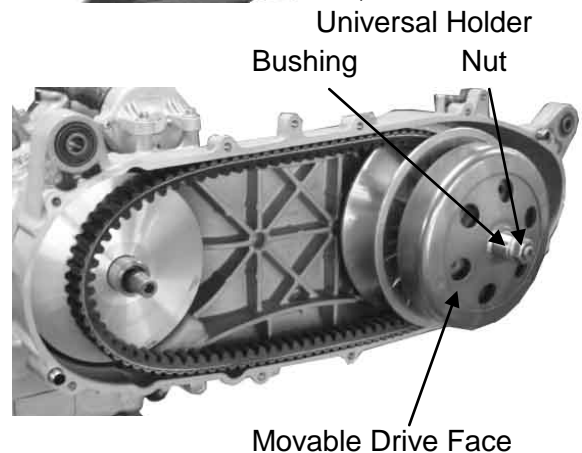
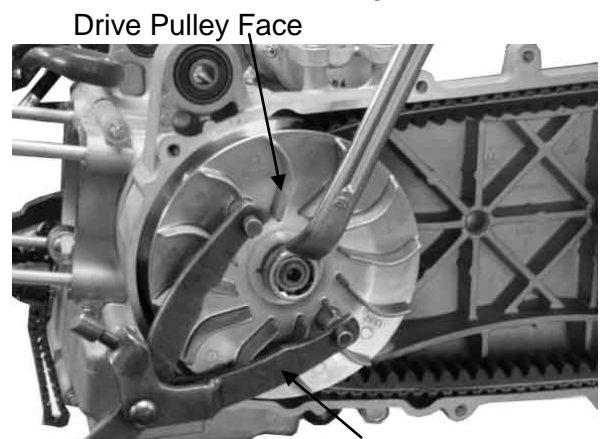
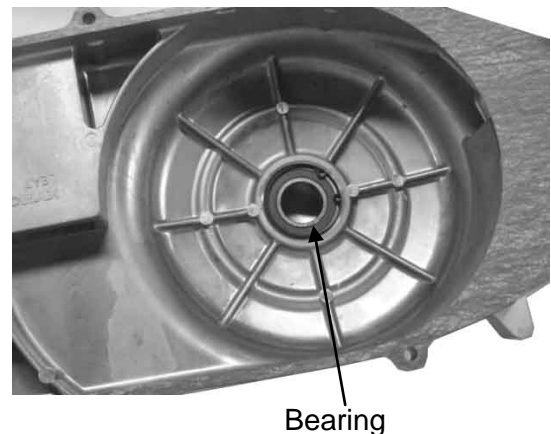

8. DRIVE AND DRIVEN PULLEYS/ V-BELT

INSPECTION

Check the drive belt for cracks, separation or abnormal or excessive wear.

Replace a new belt at every 20,000km.

- * • Use specified genuine parts for replacement.



MOVABLE DRIVE FACE ASSEMBLY

Remove the pulley face, clutch outer, driven pulley and belt.
Remove the movable drive face assembly.
Remove the drive pulley collar.

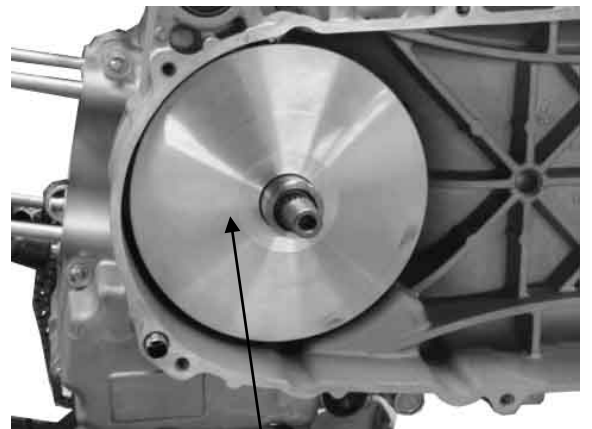

Movable Drive Face Assembly

DISASSEMBLY

Remove the ramp plate.

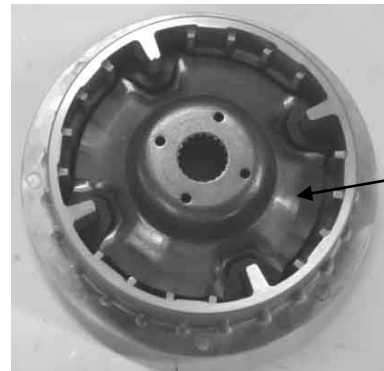

Ramp Plate

Remove the weight rollers.

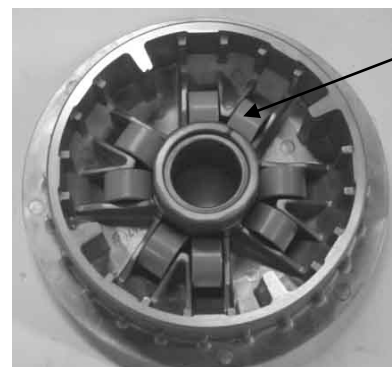

Weight Roller

8. DRIVE AND DRIVEN PULLEYS/ V-BELT

INSPECTION

Check each weight roller for wear or damage.



Check the movable drive face bushing for wear or damage.



ASSEMBLY

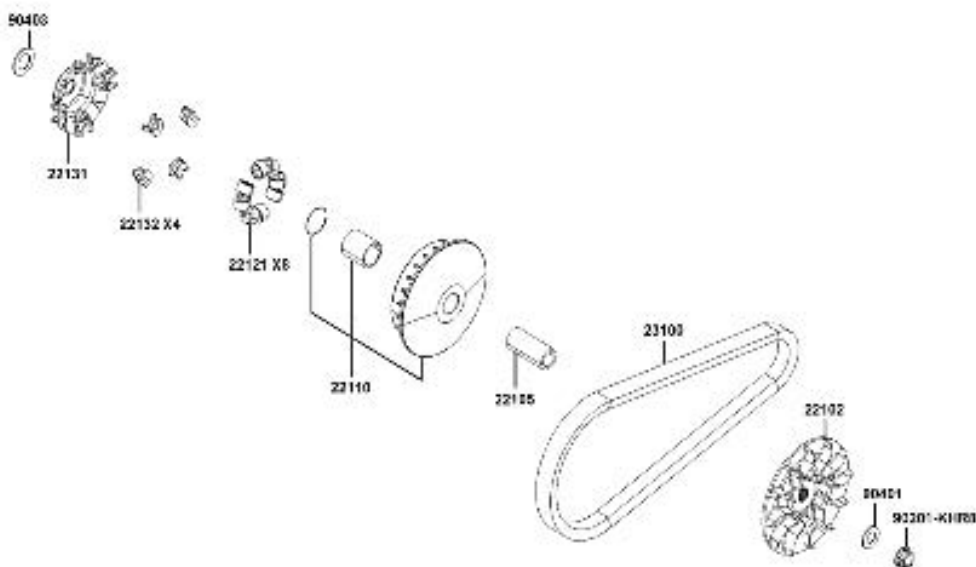

8. DRIVE AND DRIVEN PULLEYS/ V-BELT

Install the weight rollers into the movable drive face.

- * The direction of all weight rolls is same. The color side is towards to clockwise.

Install the ramp plate.

Insert the drive pulley collar into the movable drive face.

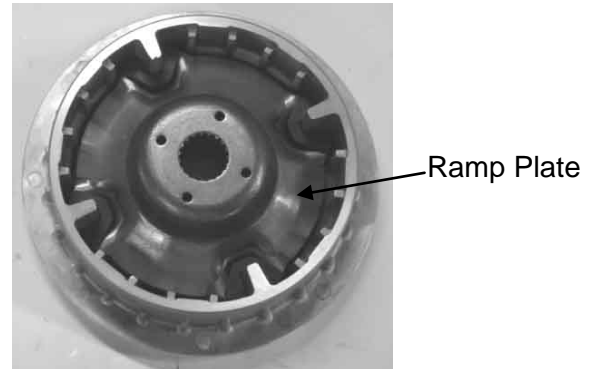

INSPECTION

Inspect the clutch outer for wear or damage.
Measure the clutch outer I.D.

Service Limit: 153.5 mm replace if over

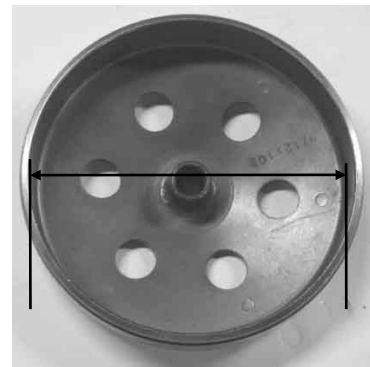

Check the clutch shoes for wear or damage.
Measure the clutch lining thickness.

Service Limit: 2.0 mm replace if below

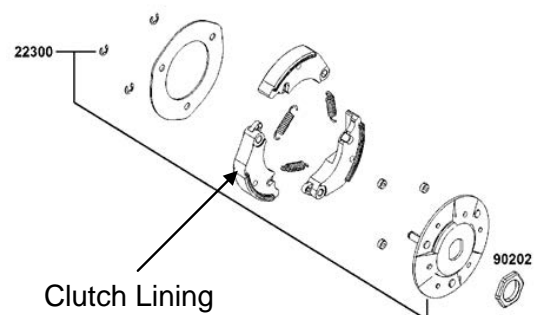

8. DRIVE AND DRIVEN PULLEYS/ V-BELT

CLUTCH/DRIVEN PULLEY DISASSEMBLY

Hold the clutch/driven pulley assembly with the clutch spring compressor.
Set the tool in a vise and remove the clutch drive plate nut.

* Be sure to use a clutch spring compressor to avoid spring damage.

Special

- Clutch Spring Compressor E053
- Fittings & Nut Wrench, 41mm E033

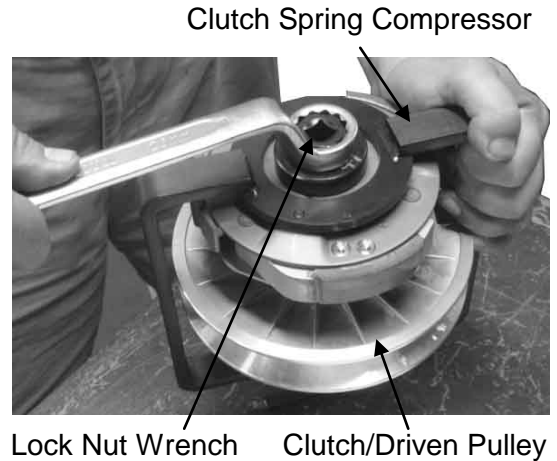

Loosen the clutch spring compressor and disassemble the clutch/driven pulley assembly.
Remove the seal collar.

Pull out the guide roller pins and guide rollers.
Remove the movable driven face from the driven face.

Remove the oil seal from the movable driven face.



ASSEMBLY

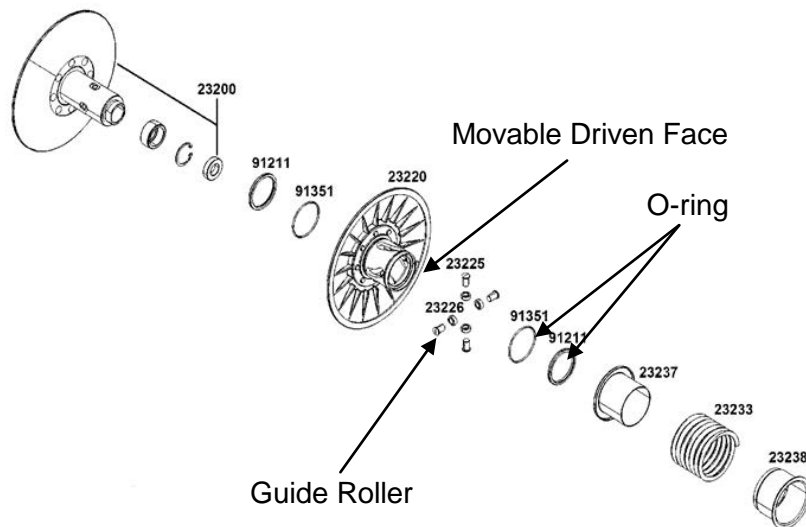

8. DRIVE AND DRIVEN PULLEYS/ V-BELT

INSPECTION

Measure the driven face spring free length.

Service Limit: 136 mm replace if below

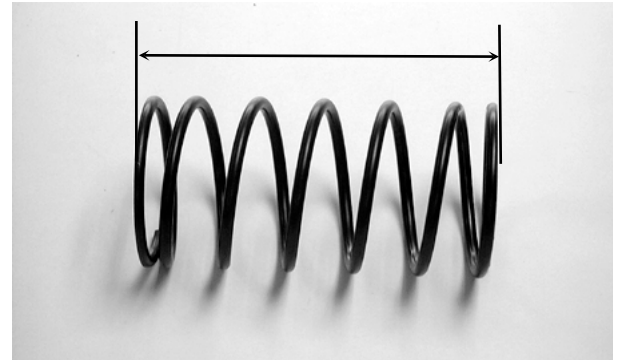

DRIVEN PULLEY FACE BEARING REPLACEMENT

Check the bearings for play and replace them if they have excessive play.

Drive the inner needle bearing out of the driven pulley face.

- * Discard the removed bearing and replace with a new one.

Remove the snap ring and drive the outer bearing out of the driven face.

- * Discard the removed bearing and replace with a new one.

Apply grease to the outer bearing.
Drive a new outer bearing into the driven face with the sealed end facing up.

Seat the snap ring in its groove.
Apply grease to the driven face bore areas.

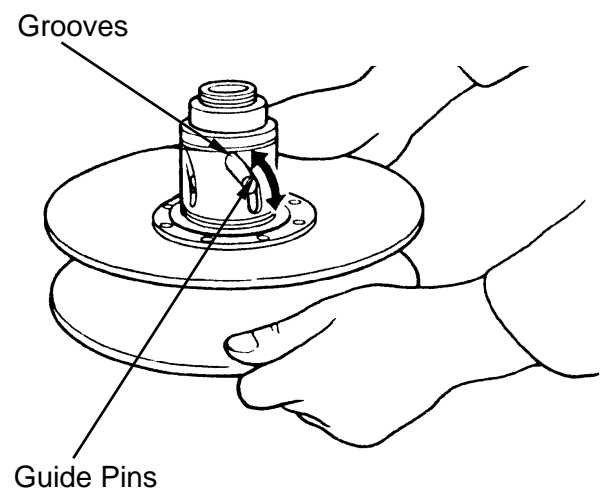

8. DRIVE AND DRIVEN PULLEYS/ V-BELT

Press a new needle bearing into the driven face.

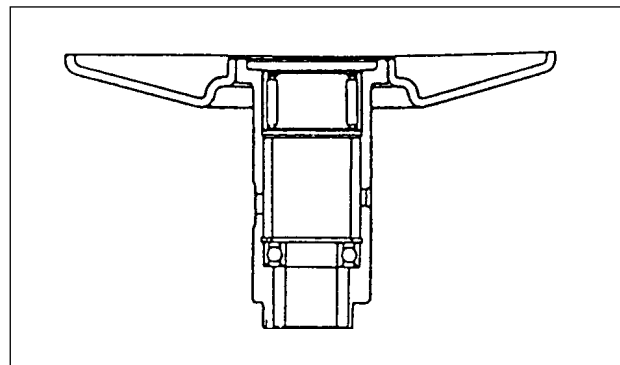

CLUTCH DISASSEMBLY

Remove the clips and retainer plate to disassemble the clutch.

* • Keep grease off the clutch linings.

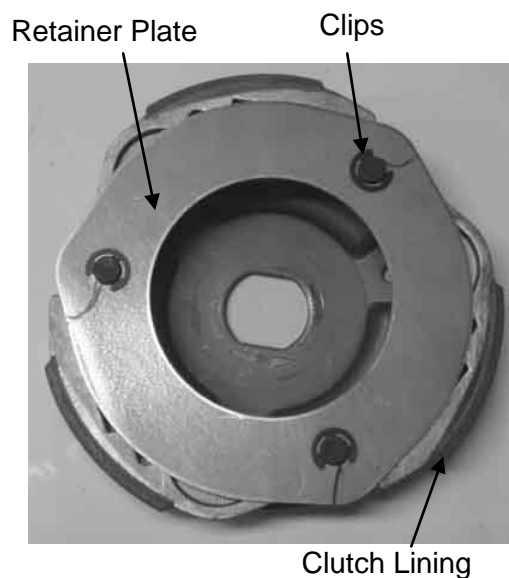

8. DRIVE AND DRIVEN PULLEYS/ V-BELT

CLUTCH ASSEMBLY

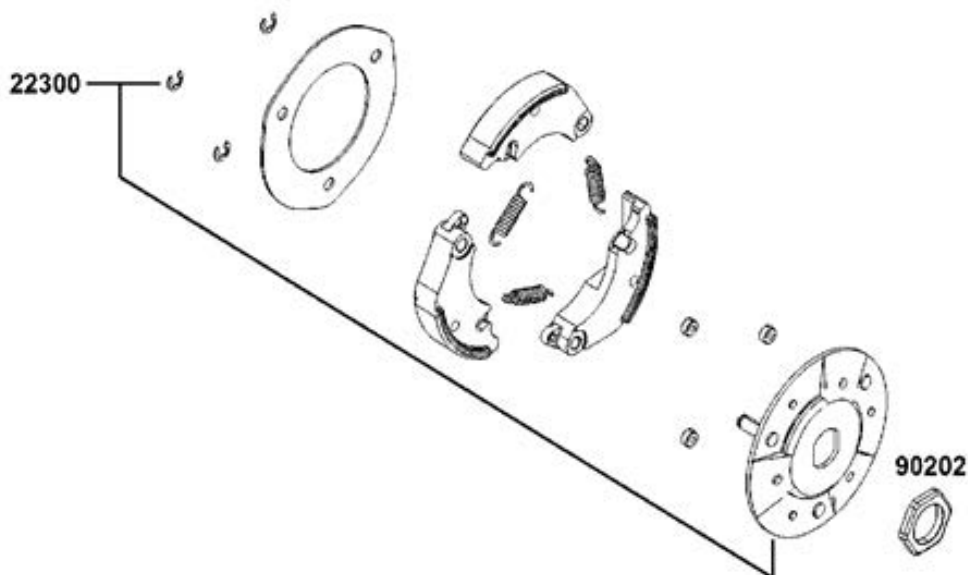

Install the damper rubbers on the drive plate pins.
Install the clutch weights/shoes and clutch springs onto the drive plate.
Install the retainer plate and secure with the clips.

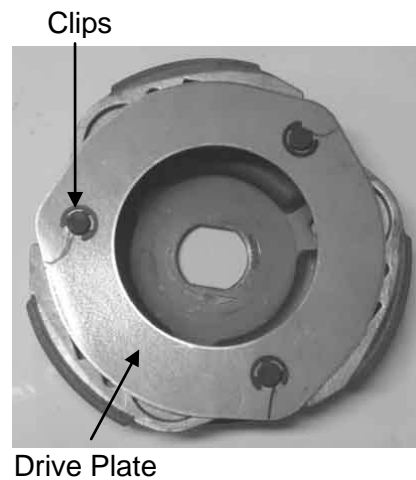

CLUTCH / DRIVEN PULLEY ASSEMBLY

Clean the pulley faces and remove any grease from them.
Apply grease to the O-rings and install them onto the moveable driven face.

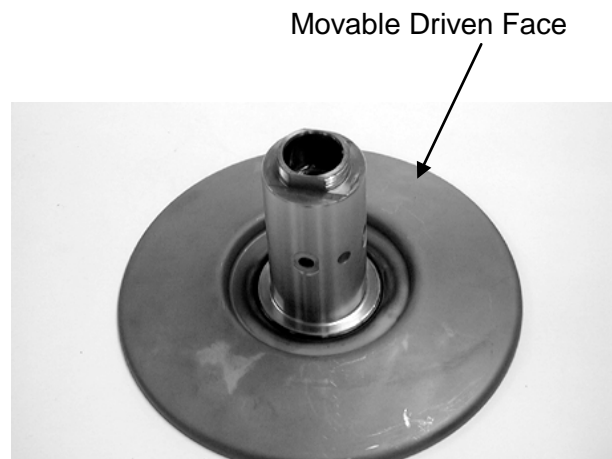

8. DRIVE AND DRIVEN PULLEYS/ V-BELT

Install the movable driven face onto the driven face.

Apply grease to the guide rollers and guide roller pins and then install them into the holes of the driven face.

Install the seal collar.

Remove any excessive grease.

- * Be sure to clean the driven face off any grease.

Set the driven pulley assembly, driven face spring and clutch assembly onto the clutch spring compressor.

- * Align the flat surface of the driven face with the flat on the clutch drive plate.

Compress the tool and install the drive plate nut.

Set the tool in a vise and tighten the drive plate nut to the specified torque.

Torque: 75 N-m

- * Be sure to use a clutch spring compressor to avoid spring damage.

Special

Clutch Spring Compressor E053
Fittings & Nut Wrench, 41mm E033

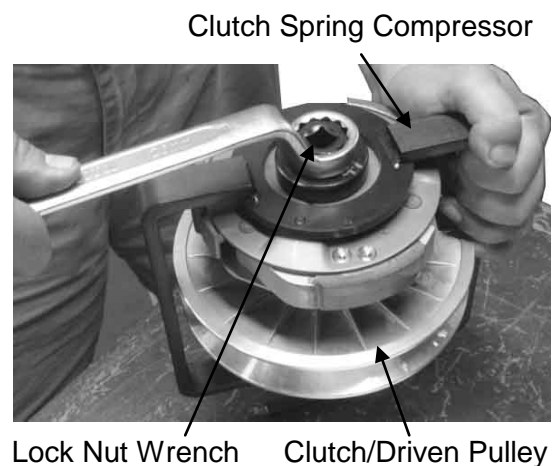
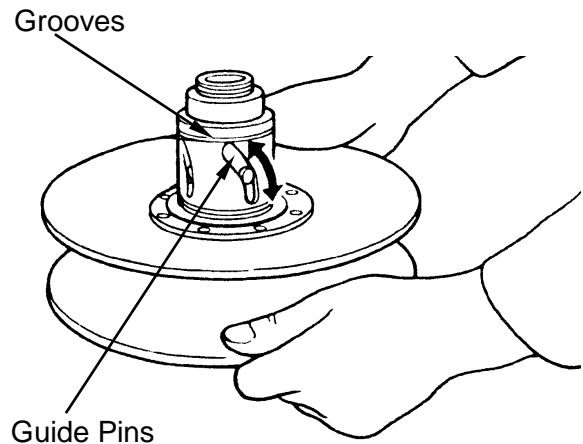

8. DRIVE AND DRIVEN PULLEYS/ V-BELT

INSTALLATION

Install the movable drive face assembly and drive pulley collar onto the crankshaft.

Drive Pulley Collar

Movable Drive Face Assembly

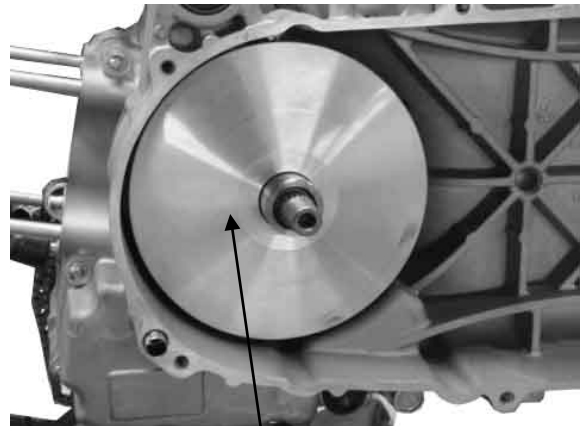

Movable Drive Face Assembly

Put the drive belt on the driven pulley.
Put the drive belt on the drive pulley collar.
Install the clutch/driven pulley and clutch outer onto the drive shaft.

- * • Keep grease off the drive shaft.

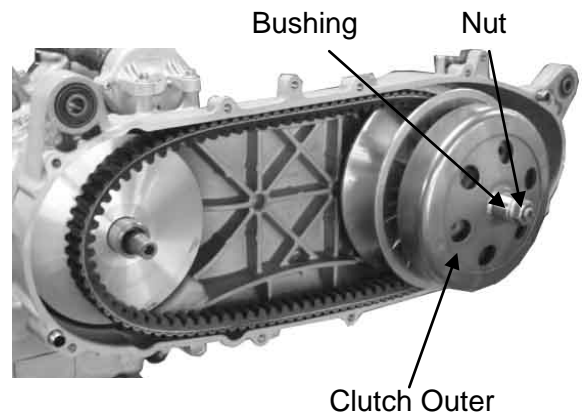

Install washer and the clutch outer nut.
Hold the clutch outer with the universal holder to tighten clutch outer nut.

Torque: 54 N-m

Special

Universal HolderE017

Install the drive pulley face, washer and drive face nut.

Hold the drive pulley with the universal holder and tighten the drive face nut.

Torque: 93.1 N-m

- * • Do not get oil or grease on the drive belt or drive pulley faces.

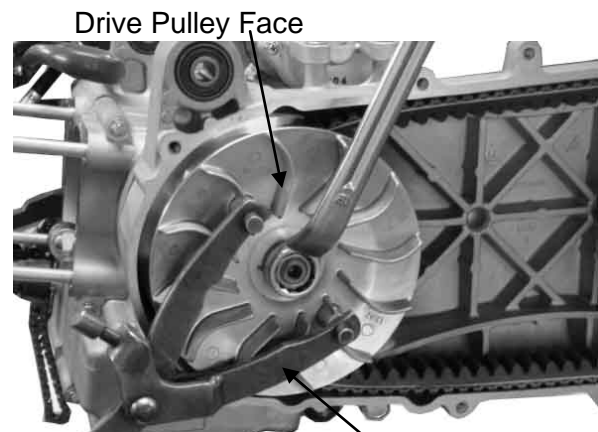

Universal Holder

8. DRIVE AND DRIVEN PULLEYS/ V-BELT

Install the left crankcase cover.



Left Crankcase Cover

9. FINAL REDUCTION

FINAL REDUCTION

SCHEMATIC DRAWING	9-1
SERVICE INFORMATION	9-2
TROUBLESHOOTING	9-2
FINAL REDUCTION DISASSEMBLY	9-3
FINAL REDUCTION INSPECTION	9-3
FINAL REDUCTION ASSEMBLY	9-5



9. FINAL REDUCTION

SCHEMATIC DRAWING

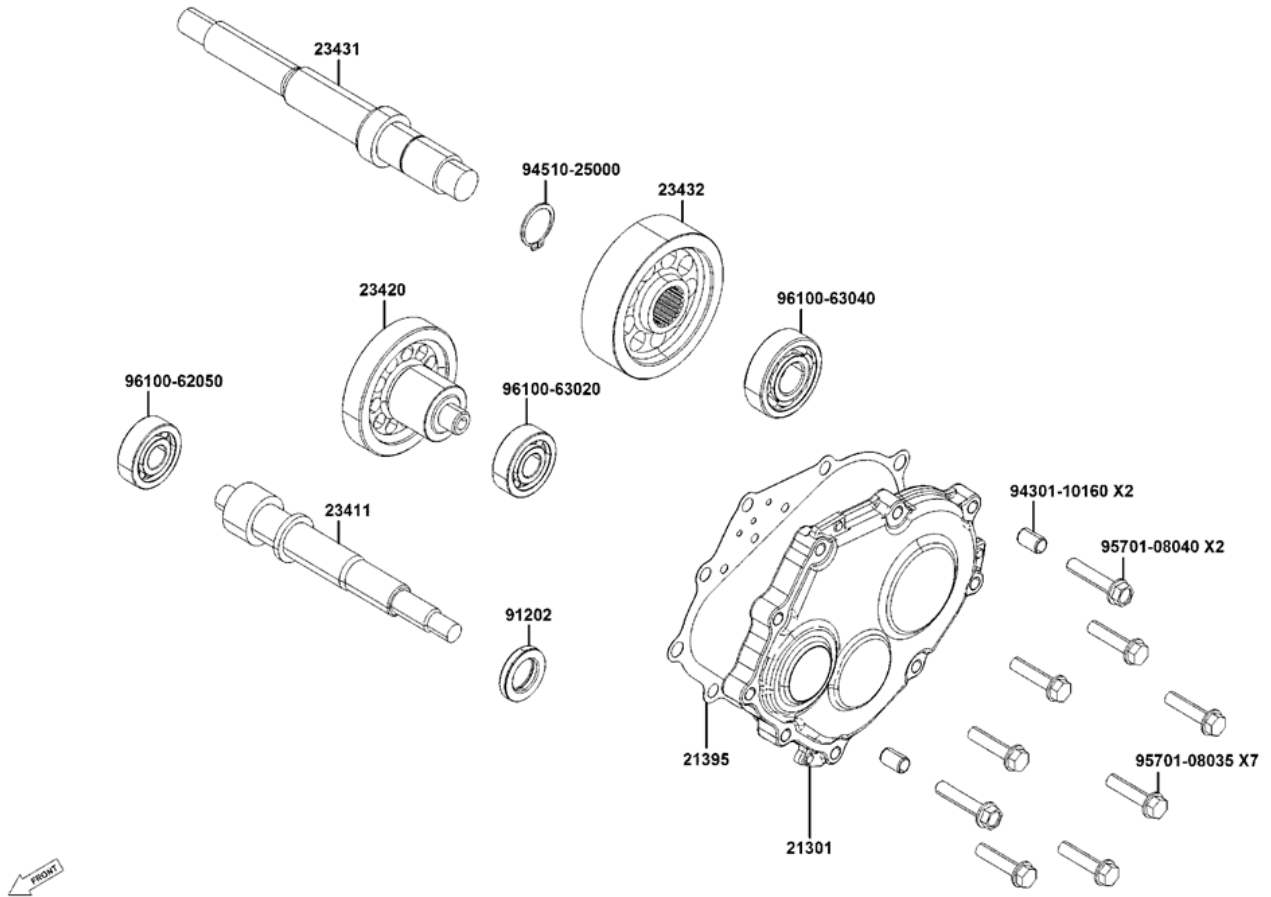

9. FINAL REDUCTION

SERVICE INFORMATION

GENERAL INSTRUCTIONS

- The servicing operations of this section can be made with the engine installed.
- When replacing the drive shaft, use a special tool to hold the bearing inner race for this operation.

SPECIFICATIONS

Specified Oil: SAE 90#

Oil Capacity:

At disassembly: 0.23 liter

At change: 0.20 liter

TORQUE VALUES

Transmission case bolt

0.8-1.2 kgf-m (9.8 N-m)

Oil check/drain bolt

1.8-2.2 kgf-m (19.7 N-m)

SPECIAL TOOLS

Bearing puller

E037

TROUBLESHOOTING

Engine starts but motorcycle won't move

- Damaged transmission
- Seized or burnt transmission

Abnormal noise

- Worn, seized or chipped gears
- Worn bearing

Oil leaks

- Oil level too high
- Worn or damaged oil seal

9. FINAL REDUCTION

FINAL REDUCTION DISASSEMBLY

- Remove the exhaust muffler.
- Remove the rear brake caliper.
- Remove the right rear shock absorber.
- Remove the rear fork.
- Remove the rear wheel.
- Remove the left crankcase cover.
- Remove the clutch outer/driven pulleys.
- Drain the transmission gear oil into a clean container.
- Remove the transmission case cover attaching bolts.
- Remove the transmission case cover.

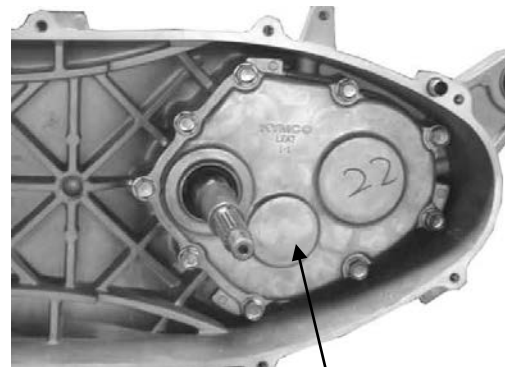

Transmission Case Cover

- Remove the gasket and dowel pins.

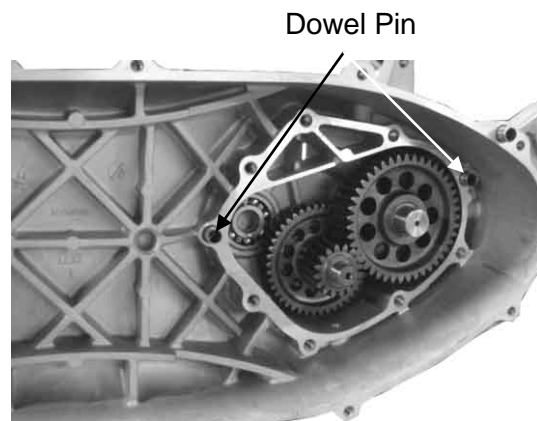

Dowel Pin

- Remove the final shaft.
- Remove the final gear and countershaft.



Final Shaft

Final Gear

FINAL REDUCTION INSPECTION

- Inspect the countershaft and gear for wear or damage.



Countershaft

9. FINAL REDUCTION

Inspect the final gear and final shaft for wear, damage or seizure.

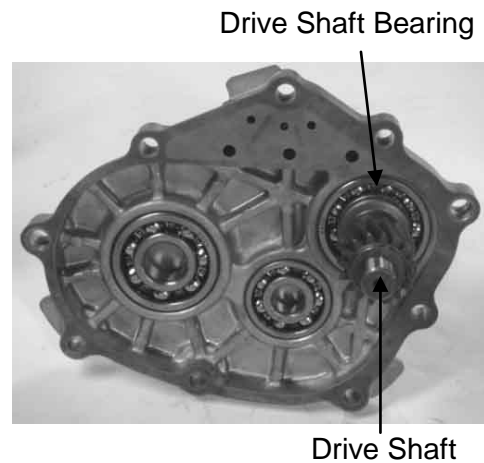

Check the left crankcase bearings for excessive play and inspect the oil seal for wear or damage.

Inspect the drive shaft and gear for wear or damage.

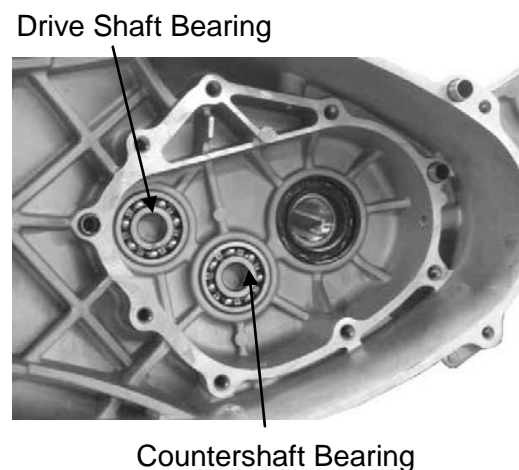

Check the transmission case covers bearings for excessive play and inspect the final shaft bearing oil seal for wear or damage.

* Do not remove the transmission case cover except for necessary part replacement. When replacing the drive shaft, also replace the bearing and oil seal.

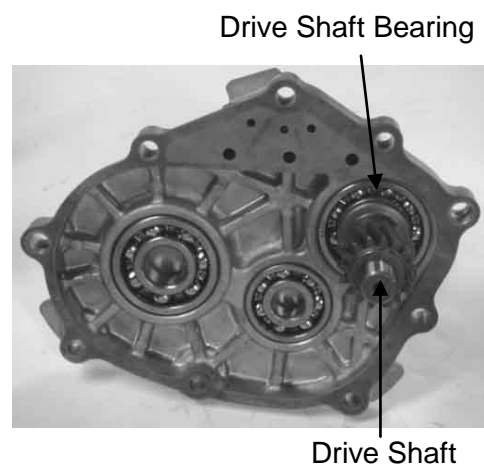

9. FINAL REDUCTION

FINAL REDUCTION ASSEMBLY

Install the drive shaft into the left crankcase.

Put the final gear on the left crankcase.

Install the countershaft and gear into the left crankcase.

Install the final shaft into the final gear and transmission case.

Install the dowel pins and a new gasket.

Install the transmission case cover.

Install and tighten the transmission case cover bolts.

Install the clutch outer/driven pulley.

Install other removed parts in the reverse order of removal.

Torque:

Transmission case bolt 0.8-1.2 kgf-m
(9.8 N-m)

After installation, fill the transmission case with the specified oil.

- Place the scooter on its main stand on level ground.
- Check the oil-sealing washer for wear or damage.

Specified Gear Oil: SAE90#

Oil Capacity:

At disassembly: 0.23 liter

At change: 0.20 liter

Install and tighten the oil check bolt.

Torque:

Oil filler/drain bolt 1.8-2.2 kgf-m (19.7 N-m)

Start the engine and check for oil leaks.

Check the oil level from the oil check bolt hole and add the specified oil to the proper level if the oil level is low.

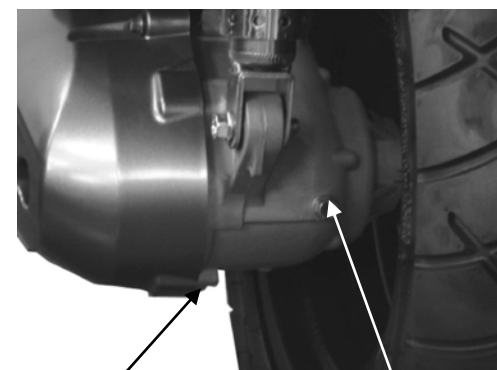
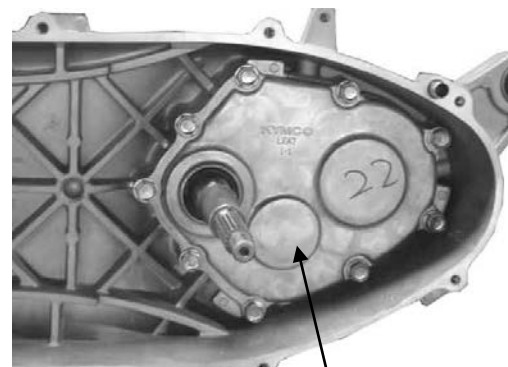
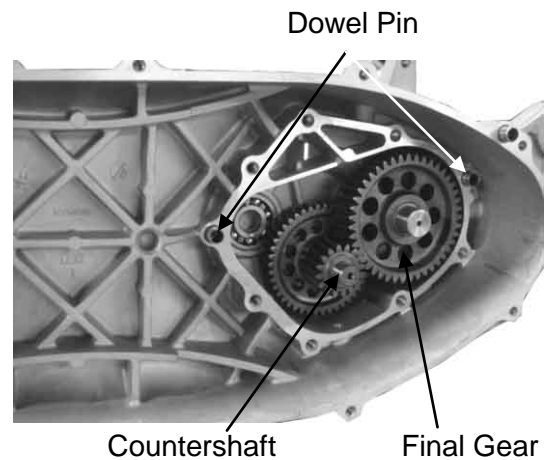

10. A.C. GENERATOR/STARTER CLUTCH

A.C. GENERATOR/STARTER CLUTCH

SCHEMATIC DRAWING	10-1
SERVICE INFORMATION	10-2
TROUBLESHOOTING	10-2
RIGHT CRANKCASE COVER REMOVAL	10-3
STATOR REMOVAL.....	10-3
FLYWHEEL REMOVAL.....	10-4
STARTER CLUTCH	10-4
FLYWHEEL INSTALLATION	10-8
STATOR INSTALLATION.....	10-9
RIGHT CRANKCASE COVER INSTALLATION	10-9

10

10. A.C. GENERATOR/STARTER CLUTCH

SCHEMATIC DRAWING

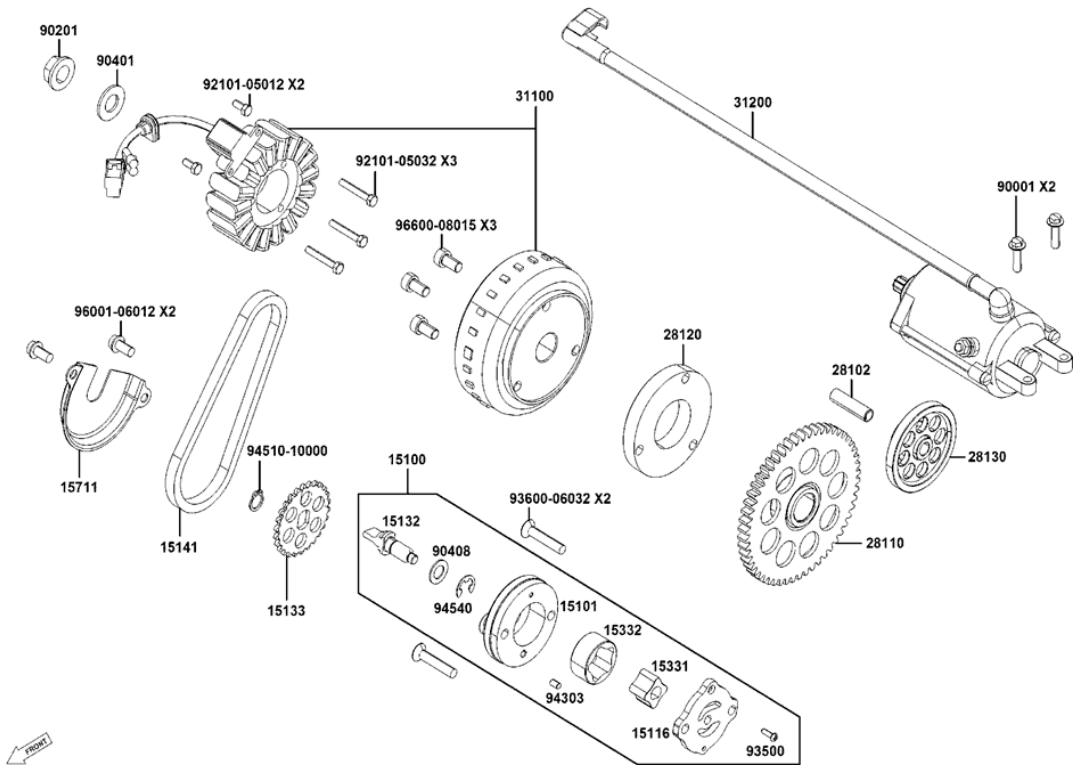
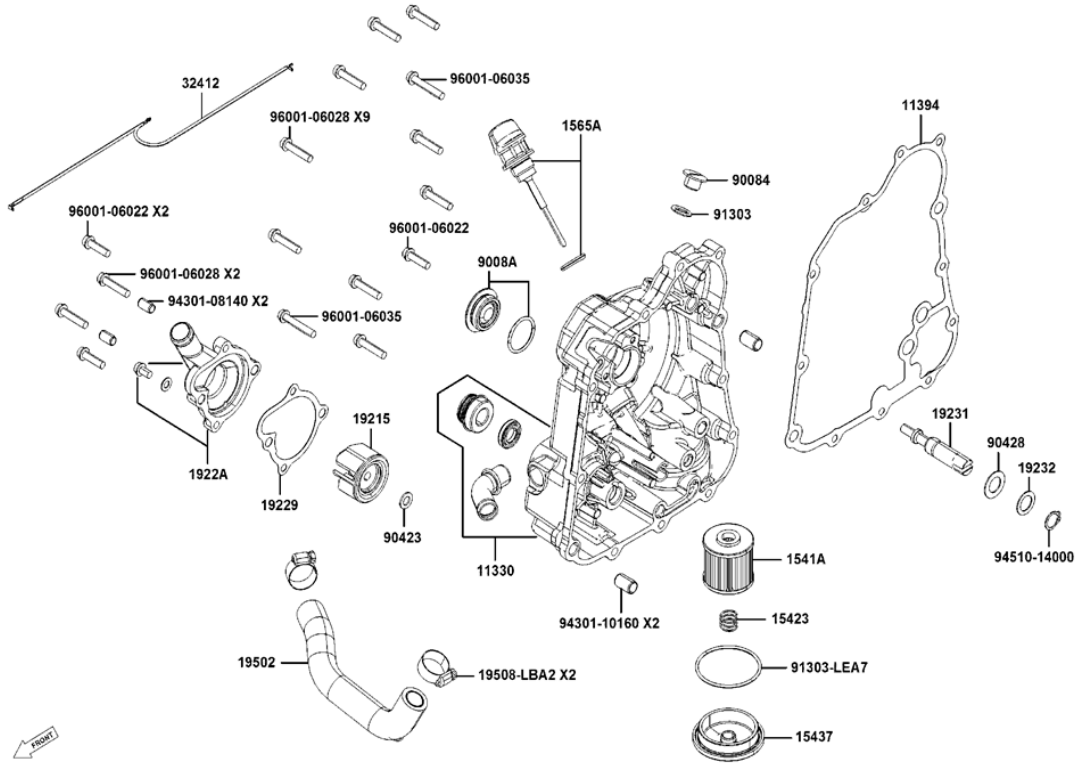

10. A.C. GENERATOR/STARTER CLUTCH

SERVICE INFORMATION

GENERAL INSTRUCTIONS

- All operations and inspections in this section can be made with the engine installed.
- Should drain the coolant before removing the right crankcase cover.
- Be careful not to drain the coolant when the engine temperature is high. (Perform this operation when the engine is cold.)
- Drain the coolant into a clean container.
- Drain the engine oil into a clean container before removing the right crankcase cover.
- When the right crankcase cover is installed, fill with the recommended engine oil and coolant. Remember to bleed air from the water hose.

SPECIFICATIONS

Engine oil: SAE 5W/50#
API-SJ above

Oil capacity at change: 1.5 Liter

Coolant capacity:

Radiator capacity:	0.766 liter
Hose with cool coolant:	0.169 liter
Hose with hot coolant:	0.194 liter
Upper limit for reserve tank capacity:	0.590 liter
Lower limit for reserve tank capacity:	0.370 liter

SPECIAL TOOLS

Flywheel puller	E003
Flywheel holder	E021

SPECIFICATIONS

Item	Standard (mm)	Service Limit (mm)
Starter driven gear I.D.	22.026~22.045	22.15mm
Starter driven gear O.D.	42.195~42.208	41.5mm

TORQUE VALUES

Flywheel nut : 5.5~6.5 kgf-m (58.8 N-m)

TROUBLESHOOTING

Refer to chapter 1 for A.C. generator troubleshooting.

Starter motor rotates but engine does not start

- Faulty starter clutch
- Starter motor rotates reversely
- Weak battery

10. A.C. GENERATOR/STARTER CLUTCH

RIGHT CRANKCASE COVER REMOVAL

Disconnect the water hoses from the water pump cover.

Disconnect the water hoses from the right crankcase cover.

Remove 12 bolts attaching the right crankcase cover and the cover.



Water Hose

Remove the bolt between water pump cover and oil filter.

Remove right crankcase cover.

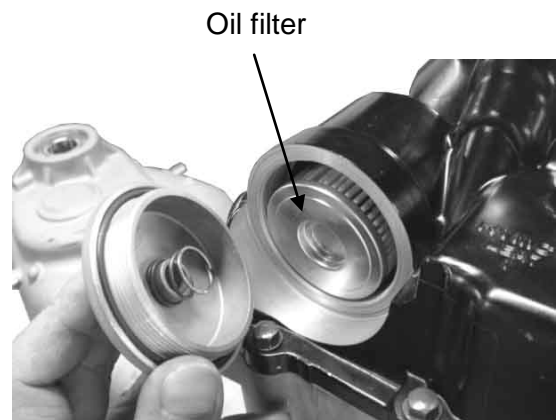

Oil filter

STATOR REMOVAL

Remove two screws attaching the pulsar coil.

Remove three A.C. generator stator bolts and the stator.

* When removing the pulsar coil and stator, be careful not to damage them to avoid short-circuit or broken wire.

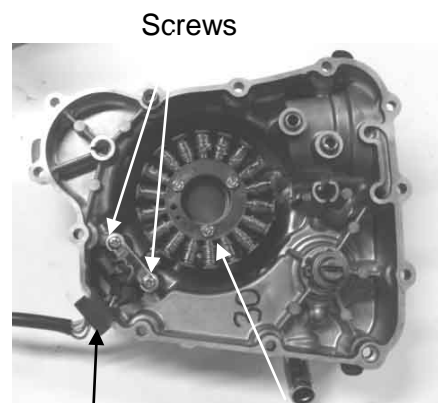

Screws

Pulsar Coil

A.C. Generator Stator

10. A.C. GENERATOR/STARTER CLUTCH

FLYWHEEL REMOVAL

Hold the flywheel with a flywheel holder and remove the flywheel nut and washer.

Special

Flywheel holder E021

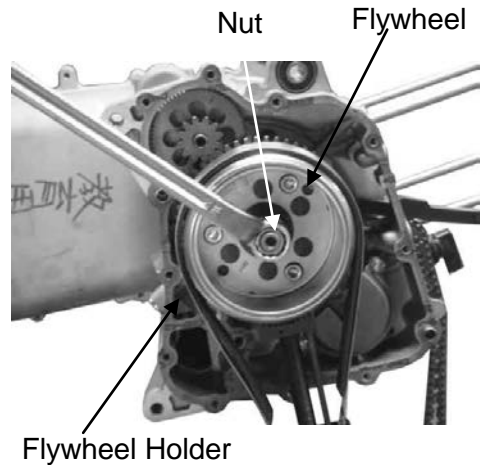

Remove the flywheel with a flywheel puller.

Special

Flywheel puller E003

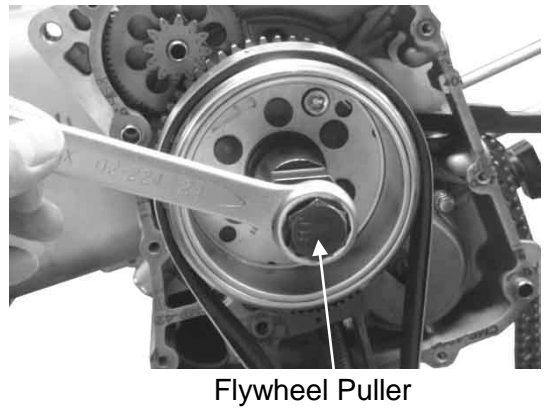

STARTER CLUTCH REMOVAL

Remove the starter driven gear.
Remove the starter idle gear and shaft.

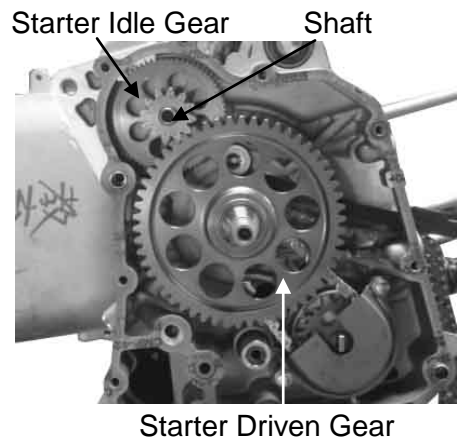

10. A.C. GENERATOR/STARTER CLUTCH

OIL PUMP REMOVAL

Remove the attaching bolts and oil separator cover.

Oil Separator Cover

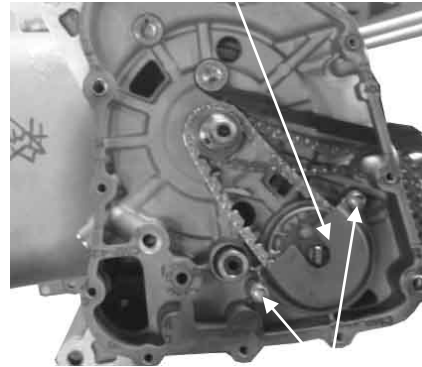

Bolts

Spread the clip off and remove the oil pump driven gear, then remove the oil pump drive chain.

Remove the cam chain.

Oil Pump Drive chain

Cam Chain

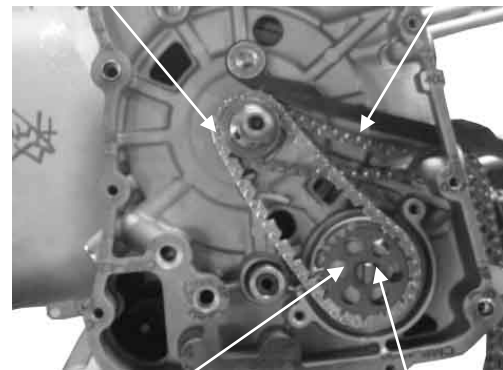

Oil Pump Driven Gear

Clip

Remove the two oil pump bolts to remove the oil pump.

Bolts

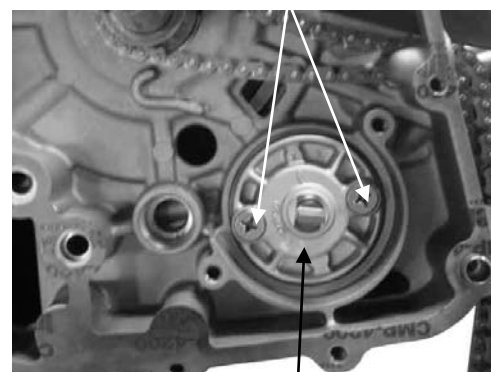

Oil pump

10. A.C. GENERATOR/STARTER CLUTCH

INSPECTION

Inspect the starter driven gear for wear or damage.

Measure the starter driven gear I.D. and O.D.

Service Limits:

I.D.: 22.15mm replace if over

O.D.: 41.50mm replace if below

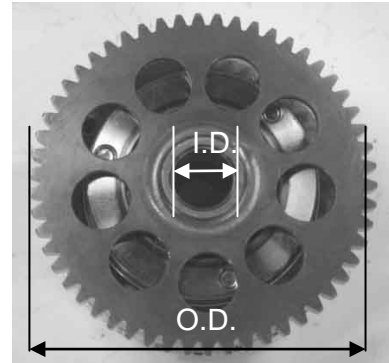

Inspect the starter idle gear and shaft for wear or damage.

Starter Idle Gear

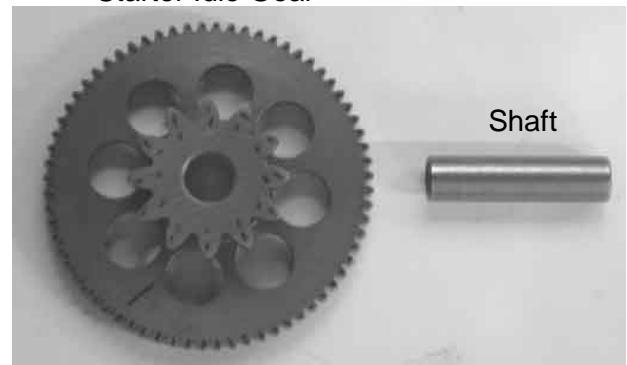

Inspect the starter one-way clutch for wear or damage.

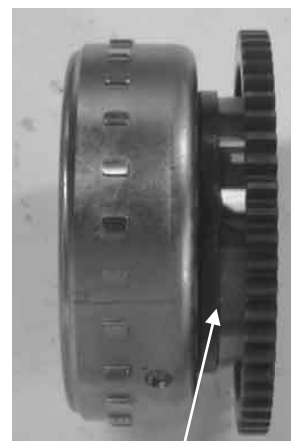

Starter One-way Clutch

10. A.C. GENERATOR/STARTER CLUTCH

INSTALLATION

Install oil pump and tighten two bolts.

Make sure that the pump shaft rotates freely.

The arrow of oil pump is upside.

Install cam chain.

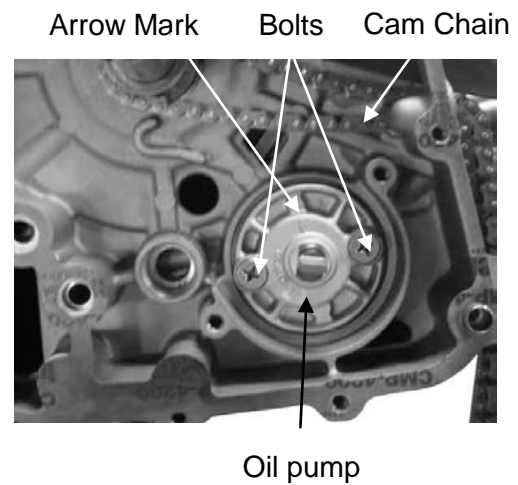

Install the pump drive chain and driven gear, then set the clip securely on the pump shaft.

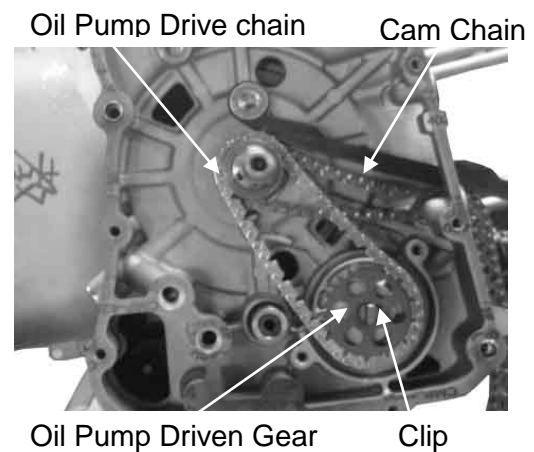

Install the oil separator cover properly.

* Fit the tab of the separator cover into the slit in the separator.

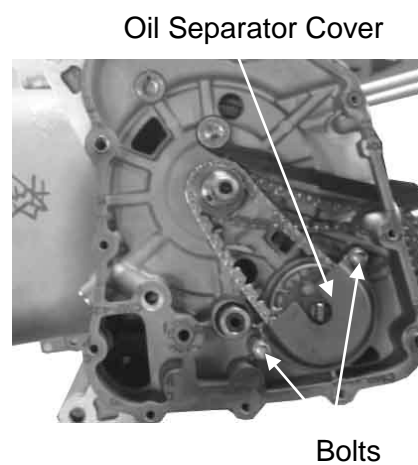

10. A.C. GENERATOR/STARTER CLUTCH

Install the starter idle gear and shaft.
Install the starter driven gear onto the crankshaft.

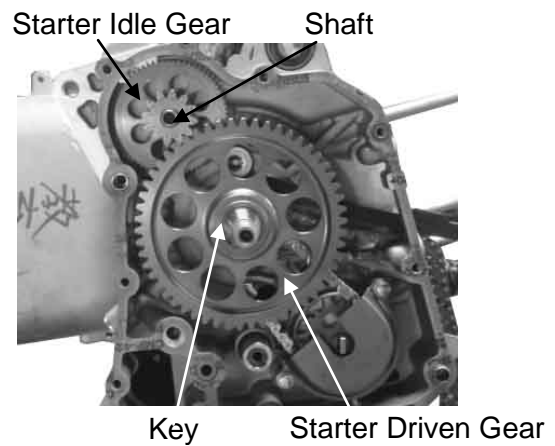

FLYWHEEL INSTALLATION

Install the flywheel onto the crankshaft by aligning the key on the crankshaft with the groove in the flywheel.

- * • Before installation, check and make sure that the inside of the flywheel is not contaminated.

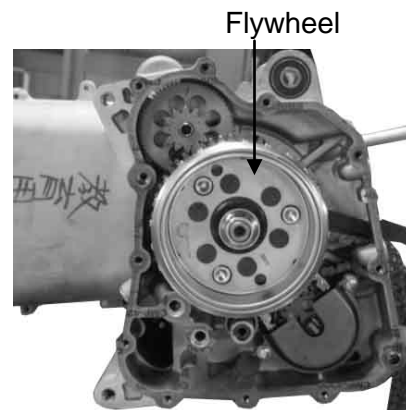

Install washer and nut.
Hold the flywheel with the flywheel holder and tighten the flywheel nut.

Torque: 5.5~6.5 kgf-m (58.8 N-m)
Remove the flywheel nut and washer.

Special

Flywheel holder E021

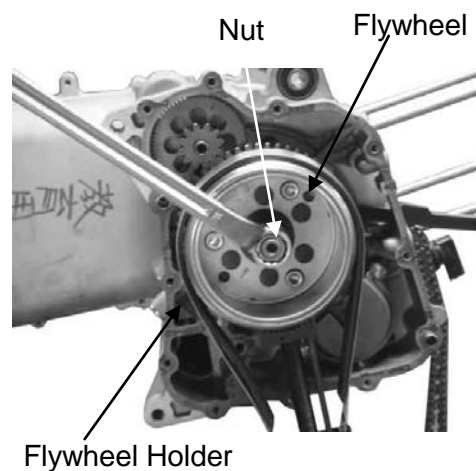

10. A.C. GENERATOR/STARTER CLUTCH

STATOR INSTALLATION

Install the A.C. generator stator on the right crankcase cover and secure it with the three bolts.

Install the pulsar coil on the right crankcase cover and secure it with the two screws.

Install the wire grommet in the groove in the right crankcase cover securely.

* Be sure to route the stator wire under the pulsar coil.

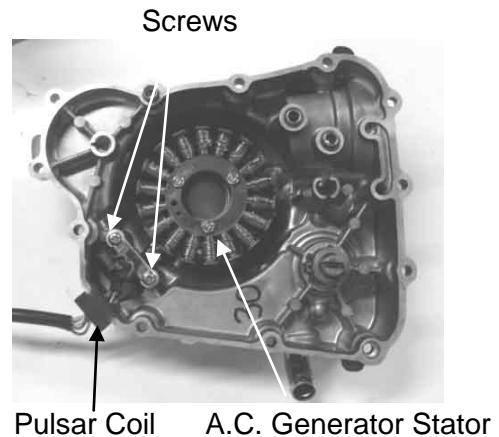

RIGHT CRANKCASE COVER INSTALLATION

Install the two dowel pins and a new gasket.

Install the right crankcase cover over the crankcase, aligning the water pump shaft groove with the oil pump shaft.

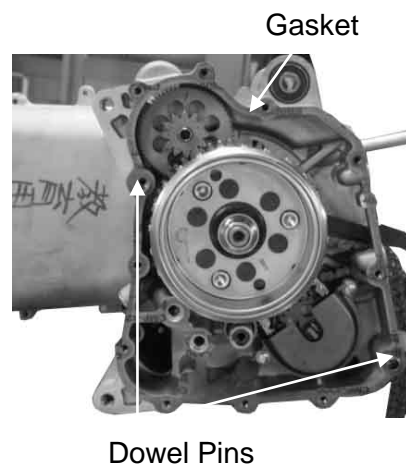

Tighten 12 bolts attaching to right crankcase cover.

Connect the water hoses to the right crankcase cover and water pump cover.

Add the recommended engine oil.

Fill the cooling system with the specified coolant.

* Be sure to bleed air from the water hose after filling the coolant.

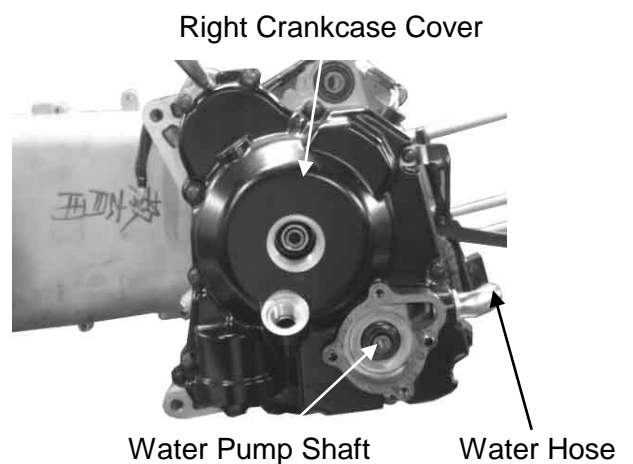

11. CRANKCASE/CRANKSHAFT

CRANKCASE/CRANKSHAFT

SCHEMATIC DRAWING	11-1
SERVICE INFORMATION	11-2
TROUBLESHOOTING	11-2
CRANKCASE SEPARATION.....	11-3
CRANKSHAFT INSPECTION.....	11-4
CRANKCASE ASSEMBLY	11-5

11. CRANKCASE/CRANKSHAFT

SCHEMATIC DRAWING

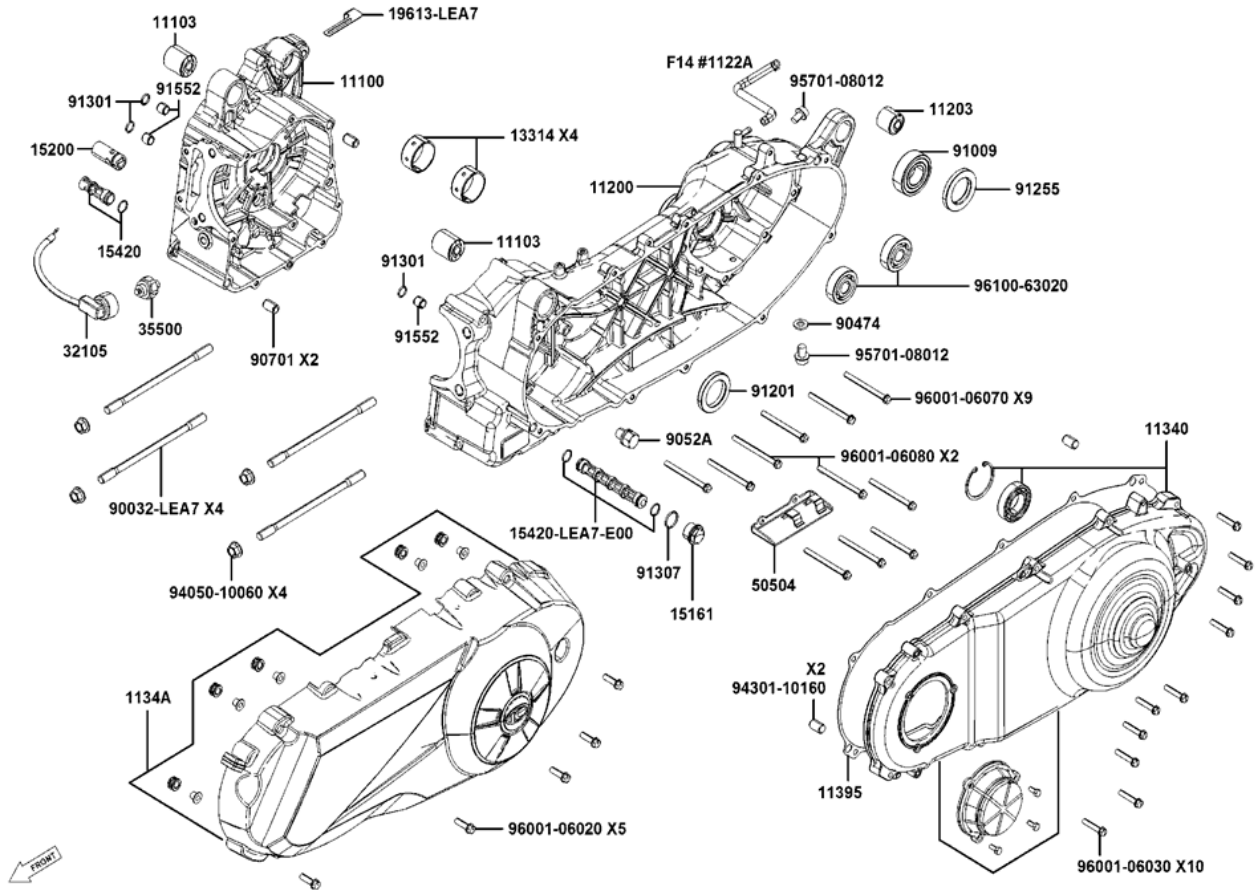

11. CRANKCASE/CRANKSHAFT

SERVICE INFORMATION

GENERAL INSTRUCTIONS

- This section covers crankcase separation to service the crankshaft. The engine must be removed for this operation.
- When separating the crankcase, never use a driver to knock the crankcase forcedly to prevent damaging the mating surfaces.
- When installing the crankcase, do not use an iron hammer to tap it.
- When installing the crankcase or crankshaft, must be replaced in pair.
- The following parts must be removed before separating the crankcase.

Cylinder head

Cylinder/piston

Right crankcase cover/drive and driven pulley

A.C. generator/starter clutch

Rear wheel/rear shock absorber

Starter motor

Oil pump

SPECIFICATIONS

	Item	Standard (mm)	Service Limit (mm)
Crankshaft	Connecting rod big end side clearance	0.15~0.35	0.6
	Connecting rod big end radial clearance	0~0.008	0.05

TORQUE VALUES

Crankcase cover bolt 1.0~1.4 kgf-m (11.8 N-m)

Cam chain tensioner pivot 0.8~1.2 kgf-m (9.8 N-m)

TROUBLESHOOTING

Excessive engine noise

- Excessive bearing play
- Excessive crankpin bearing play
- Worn piston pin and piston pin hole

11. CRANKCASE/CRANKSHAFT

CRANKCASE SEPARATION

Remove bolts attaching left crankcase.
Place the crankcase with the left crankcase
down and remove the right crankcase from
the left crankcase.

- * • Never use a driver to knock the
crankcase mating surfaces apart.



Remove the engine oil screen.

Engine oil screen



Remove the crankshaft from the left
crankcase.

Left Crankcase Crankshaft

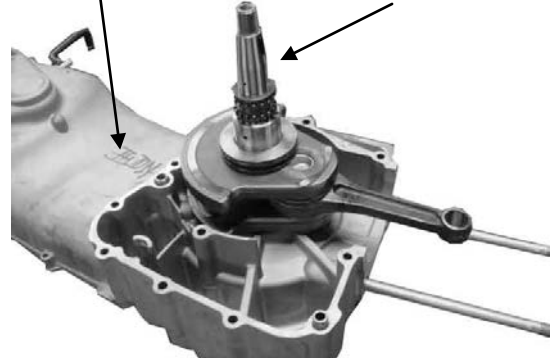

11. CRANKCASE/CRANKSHAFT

Remove the oil seal from the left crankcase.

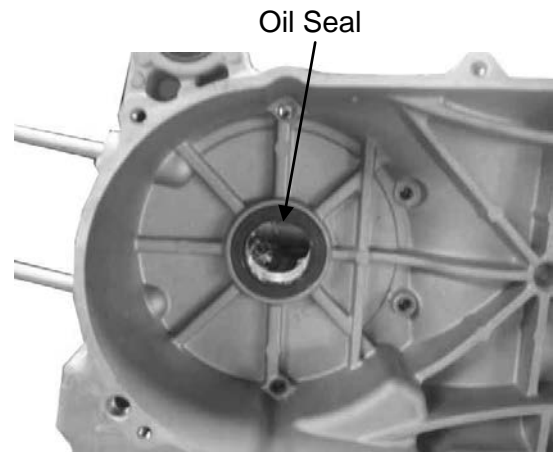

CRANKSHAFT INSPECTION

Measure the connecting rod big end side clearance.

Service Limit: 0.6 mm replace if over

Measure the connecting rod small end I.D.

Service Limit: 17.06 mm replace if over

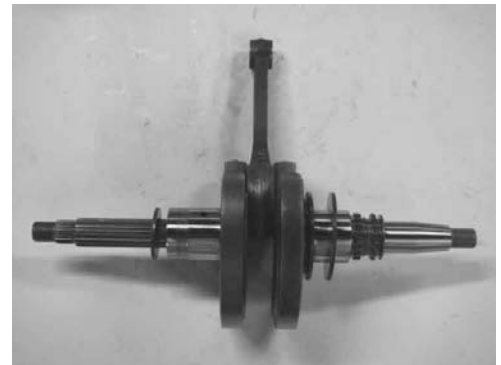

Measure the crankshaft bearing play.

Service Limits:

Axial : 0.20 mm replace if over

Radial: 0.05 mm replace if over

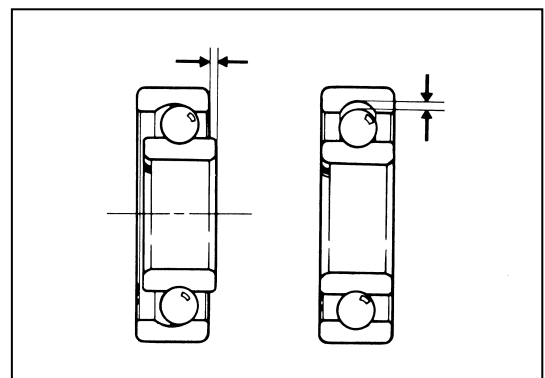

11. CRANKCASE/CRANKSHAFT

CRANKCASE ASSEMBLY

Install a new oil seal onto the left crankcase.
Place the left crankcase down and install the crankshaft into the left crankcase.

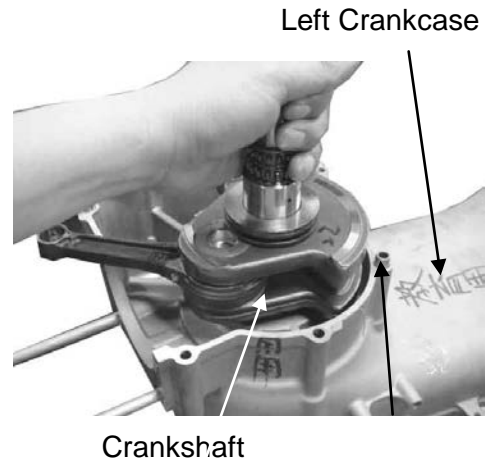

- *
 - Avoid damaging the oil seal.
 - Apply grease to the lip of the oil seal.

- *
 - Avoid damaging the crankcase mating surfaces.

Install the two dowel pins.

Place the right crankcase over the crankshaft and onto the left crankcase.

- *
 - Install the right crankcase squarely and do not tap it with an iron or plastic hammer.

Install and tighten the right and left crankcase attaching bolts.

Install the engine oil screen.

- *
 - To install the crankshaft or crankcase, must be replaced in pair.

Crankcase Bearing	Crankcase mark			
	A	B	C	D
Crankshaft mark	A	B	C	D
A	black	green	green	Red
B	green	green	Red	

12. COOLING SYSTEM

COOLING DRAWING

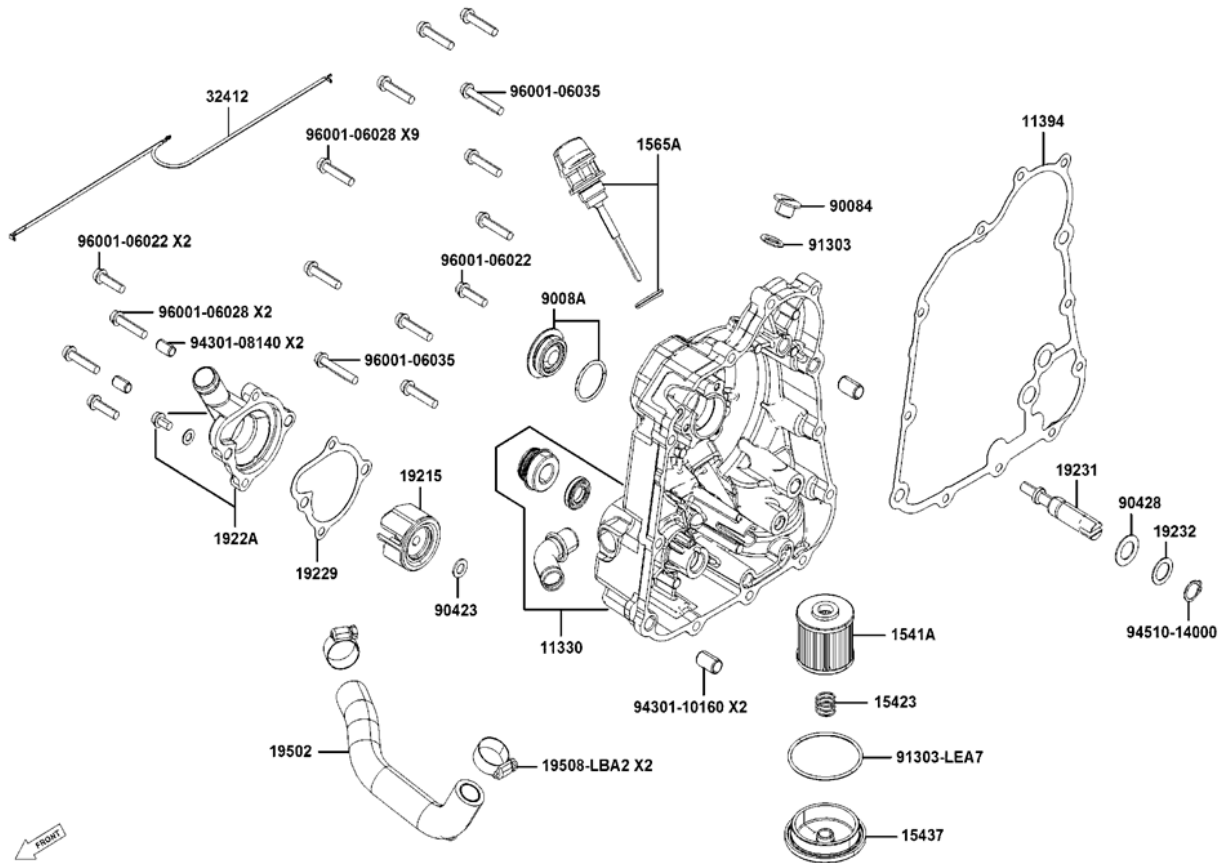

12. COOLING SYSTEM

SERVICE INFORMATION

GENERAL INSTRUCTIONS

- The water pump must be serviced after removing the engine. Other cooling system service can be done with the engine installed in the frame.
- The engine must be cool before servicing the cooling system.
When the coolant temperature is over 100°C, never remove the radiator cap to release the pressure because the boiling coolant may cause danger.
- Avoid spilling coolant on painted surfaces because the coolant will corrode the painted surfaces. Wash off any spilled coolant with fresh water as soon as possible.
- After servicing the system, check for leaks with a cooling system tester.

TORQUE VALUES

Water pump impeller	1.0~1.4 kgf-m (11.8 N-m)
Water pump cover bolt	1.0~1.4 kgf-m (11.8 N-m)

TROUBLESHOOTING

Engine temperature too high

- Faulty temperature gauge or thermosensor
- Faulty radiator cap
- Faulty thermostat
- Insufficient coolant
- Passages blocked in hoses or water jacket
- Clogged radiator fins
- Passages blocked in radiator
- Faulty water pump

Coolant leaks

- Faulty pump mechanical (water) seal
- Deteriorated O-rings
- Damaged or deteriorated water hoses

Temperature gauge shows the wrong temperature

- Faulty temperature gauge or thermosensor
- Faulty thermostat

SPECIFICATIONS

Radiator cap relief pressure		0.9±0.15 kg/cm ²	
Thermostat temperature	Begins to open	71 °C	
	Full-open	80 °C	
	Valve lift	3.5~4.5 mm	
Coolant capacity		Total 1420 cc	Radiator & Engine: 1120 cc Reserve tank: 300 cc

12. COOLING SYSTEM

COOLANT GRAVITY CHART

Temp. °C Coolant concentration	0	5	10	15	20	25	30	35	40	45	50
5%	1.009	1.009	1.008	1.008	1.007	1.006	1.005	1.003	1.001	0.009	0.997
10%	1.018	1.107	1.017	1.016	1.015	1.014	0.013	1.011	1.009	1.007	1.005
15%	1.028	1.027	1.026	1.025	1.024	1.022	1.020	1.018	1.016	1.014	1.012
20%	1.036	1.035	1.034	1.033	1.031	1.029	1.027	1.025	1.023	1.021	1.019
25%	1.045	1.044	1.043	1.042	1.040	1.038	1.036	1.034	1.031	1.028	1.025
30%	1.053	1.051	1.051	1.049	1.047	1.045	1.043	1.041	1.038	1.035	1.032
35%	1.063	1.062	1.060	1.058	1.056	1.054	1.052	1.049	1.046	1.043	1.040
40%	1.072	1.070	1.068	1.066	1.064	1.062	1.059	1.056	1.053	1.050	1.047
45%	1.080	1.078	1.076	1.074	1.072	1.069	1.056	1.063	1.062	1.057	1.054
50%	1.086	1.084	1.082	1.080	1.077	1.074	1.071	1.068	1.065	1.062	1.059
55%	1.095	1.093	1.091	1.088	1.085	1.082	1.079	1.076	1.073	1.070	1.067
60%	1.100	1.098	1.095	1.092	1.089	1.086	1.083	1.080	1.077	1.074	1.071

COOLANT MIXTURE (WITH ANTI-RUST AND ANTI-FREEZING EFFECTS)

Freezing Point	Mixing Rate	KYMCO SIGMA Coolant Concentrate	Distilled Water
-9°C	20 %	284cc	1136cc
-15°C	30 %	426cc	994cc
-25°C	40 %	568cc	852cc
-37°C	50 %	710cc	710cc
-44.5°C	55 %	781cc	639cc

- Use coolant of specified mixing rate 40%:60%. (The mixing rate of 448cc KYMCO SIGMA coolant concentrate + 672cc distilled water)
- Do not mix coolant concentrate of different brands.
- Do not drink the coolant, which is poisonous.
- The freezing point of coolant mixture shall be 5°C lower than the freezing point of the riding area.

12. COOLING SYSTEM

COOLING SYSTEM TESTING RADIATOR CAP INSPECTION

Install the radiator cap onto the radiator tester and apply specified pressure to it. It must hold specified pressure for at least six seconds.

- * Apply water to the sealing cap surface before testing.

Radiator Cap Relief Pressure:

$0.9 \pm 0.15 \text{ kg/cm}^2$

Install the radiator tester onto the radiator and apply specified pressure to it. It must hold specified pressure for at least six seconds.

Check the water hoses and connectors for leaks.

- * The test pressure should not exceed 1.05 kg/cm^2 . Excessive pressure can damage the radiator and its hose connectors.

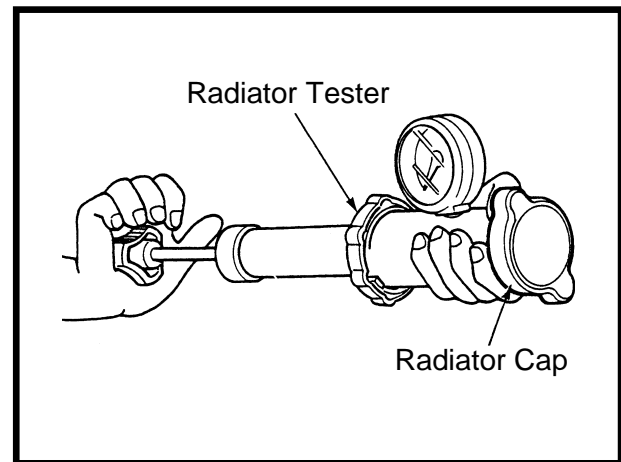

COOLANT REPLACEMENT

- * The engine must be cool before serving the cooling system, or severe scalding may result.

Open the radiator protector and remove the radiator cap.

Place a drain pan under the water pump and drain the coolant from the system by removing the drain bolt.

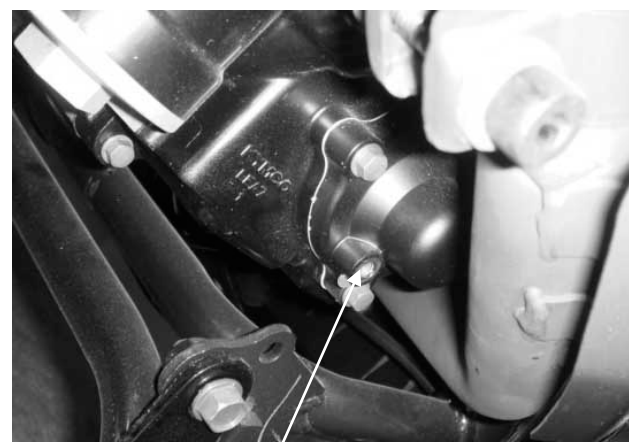

Drain Bolt

12. COOLING SYSTEM

Fill the system with a 40-60 mixture of distilled water and ethylene glycol.



Bleed air from the system

- Start the engine and allow it to run until there are no air bubbles in the coolant, and the level stabilizes.



- Open the air vent tube to see the hot coolant flow out.
- Stop the engine and add coolant up to the proper level if necessary.
- Reinstall the radiator cap.
- Check the level of coolant in the reserve tank and fill to the correct level if the level is low.
- Close the radiator protector.



Air Vent Tube

12. COOLING SYSTEM

RADIATOR

RADIATOR INSPECTION

Remove the bolt attaching to the Leg Shield.



Under Cowl

Remove the under cowl.

Inspect the radiator soldered joints and seams for leaks.

Blow dirt out from between core fins with compressed air. If insects are clogging the radiator, wash them off. Carefully straighten any bent fins.

From: Reserve Tank From: Engine

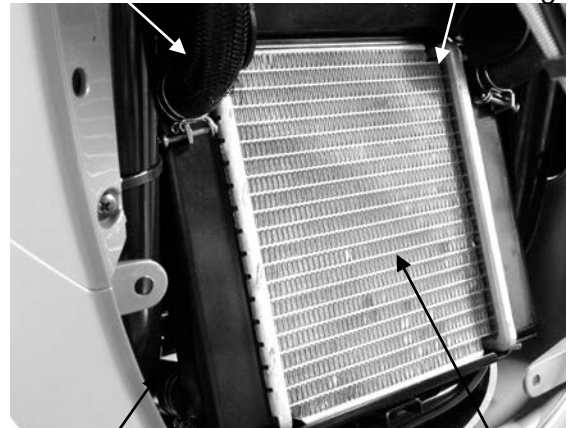

To: Water Pump

Radiator

RADIATOR REMOVAL

Drain the coolant.

Disconnect the outlet tube of the reserve tank.

Remove the overflow tube clamp and disconnect the overflow tube.

Disconnect the air vent tube from the radiator filler.

Disconnect the fan motor wire coupler.

Overflow Tube



Air Vent Tube

12. COOLING SYSTEM

Loosen the hose band and disconnect the upper hose and lower hose from the radiator.

Disconnect the thermostatic switch wire coupler.

- 37760: Thermostatic Switch
- 19014: To Water Pump
- 19013: From Thermostat
- 19016: To Reserve Tank

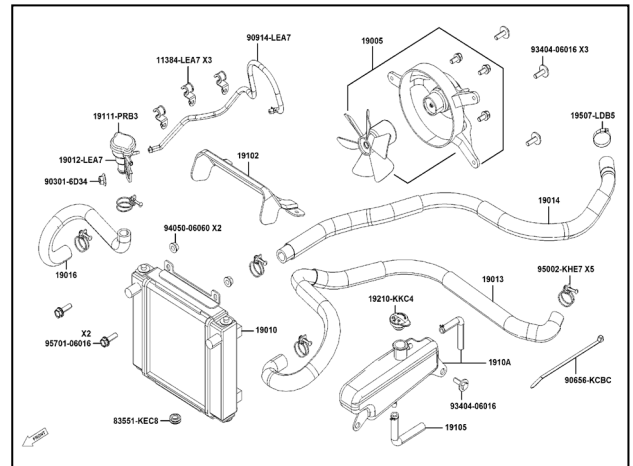

Remove two bolts/nuts on the radiator.

Remove the radiator.

- 95701-06016: Bolts
- 94050-06060: nuts

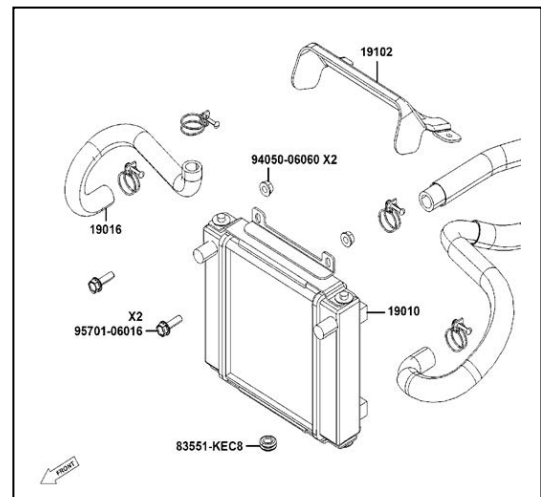

RADIATOR DISASSEMBLY

Remove three bolts and then remove the fan rubber from the radiator.

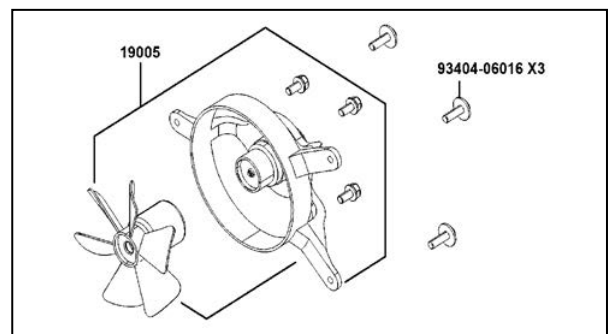

Check fan motor by battery.



12. COOLING SYSTEM

THERMOSTATIC SWITCH

When the coolant temperature is lower than 85 °C, the thermostatic switch OFF.

When coolant temperature is over 90 °C, the thermostatic switch ON.

37760: Thermostatic Switch

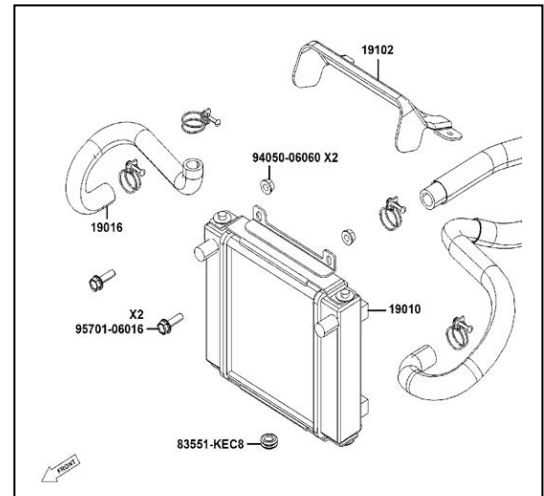

RADIATOR INSTALLATION

Install the fan rubber on the radiator with three bolts.

Install the radiator on the radiator bracket with three bolts/nuts.

Connect the upper and lower hoses and secure them with hose bands.

Connect the thermostatic switch wire.

Connect the fan motor wire couplers.

Connect the overflow tube and secure with the tube clamp.

Fill the radiator with coolant.

Connect the vent tube to the radiator filler.

After installation, check for coolant leaks.

Connect the outlet tube of the reservoir and secure with the tube clamp.

From: Reserve Tank From: Engine



To: Water Pump

Radiator

- * If you want to refill the coolant, the following procedure must be checked.
1. Please make the radiator filler and the air vent tube to be separated.
 2. Start the engine, filled in the coolant till the coolant flowed out from the air vent tube.

12. COOLING SYSTEM

WATER PUMP

MECHANICAL SEAL (WATER SEAL) INSPECTION

Inspect the telltale hole for signs of mechanical seal coolant leakage.

If the mechanical seal is leaking, remove the right crankcase cover and replace the mechanical seal.

Right Crankcase Cover Water Pump

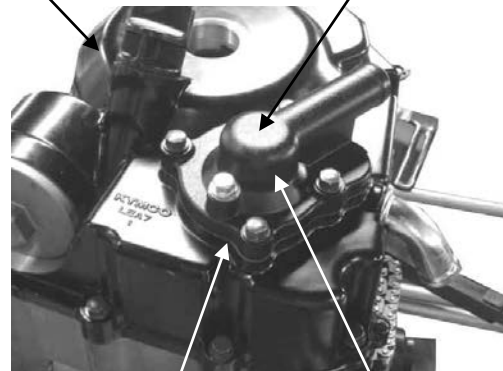

Telltale Hole Water Pump Cover

WATER PUMP/IMPELLER REMOVAL

Remove the coolant inlet hose and outlet hose.

Remove four bolts and the water pump cover, gasket and 2 dowel pins.
Remove the water pump impeller.

* The impeller has left hand threads.

Impeller Seal Washer (Porcelain)



Mechanical (Water) Seal

Inspect the mechanical (water) seal and seal washer if wear or damage.

* The mechanical seal and seal washer must be replaced as a set.



Water pump shaft

12. COOLING SYSTEM

WATER PUMP SHAFT REMOVAL

Disconnect the water hose from the right crankcase cover.
Remove bolts attaching the right crankcase cover.
Remove the water pump bearing snap ring from the water pump assembly.
Remove the water pump shaft and inner bearing.
Remove the water pump shaft outer bearing.

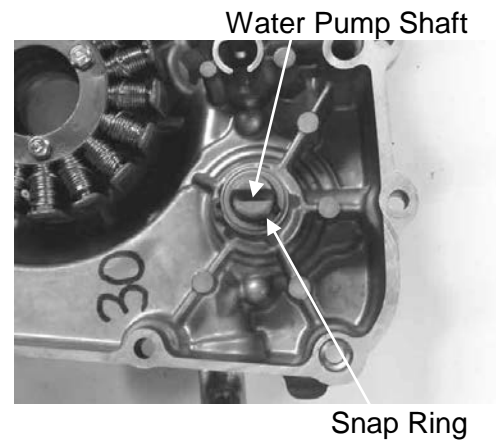

MECHANICAL SEAL REPLACEMENT

Drive the mechanical seal out of the water pump assembly from the inside.

* Apply sealant to the right crankcase cover of a new mechanical seal and then drive in the mechanical seal.

WATER PUMP SHAFT INSTALLATION

Drive a new water pump shaft outer bearing into the water pump assembly from the inside.
Install the water pump shaft and shaft inner bearing into the water pump assembly.
Install the snap ring to secure the inner bearing properly.

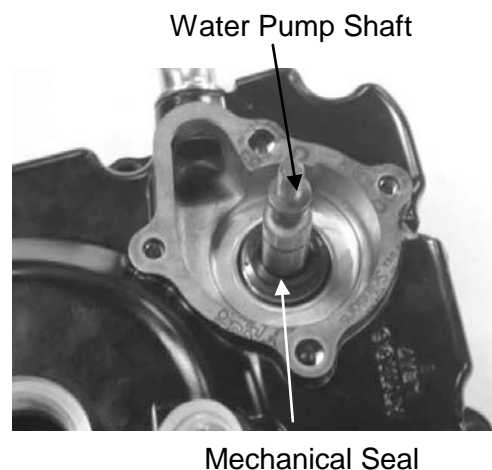

12. COOLING SYSTEM

Install the dowel pins and a new gasket and then install the water pump assembly to the right crankcase cover.

Tighten 12 bolts to secure the right crankcase cover.

* When installing the water pump assembly, aligning the groove on the water pump shaft with the tab on the oil pump shaft.

WATER PUMP/IMPELLER INSTALLATION

When the mechanical seal is replaced, a new seal washer must be installed to the impeller.

Install the impeller onto the water pump shaft.

Torque: 1.0~1.4 kgf-m (11.8 N-m)

* The impeller has left hand threads.

Install two dowel pins and a new gasket.

Install the water pump cover and tighten the 4 bolts.

Torque: 1.0~1.4 kgf-m (11.8 N-m)

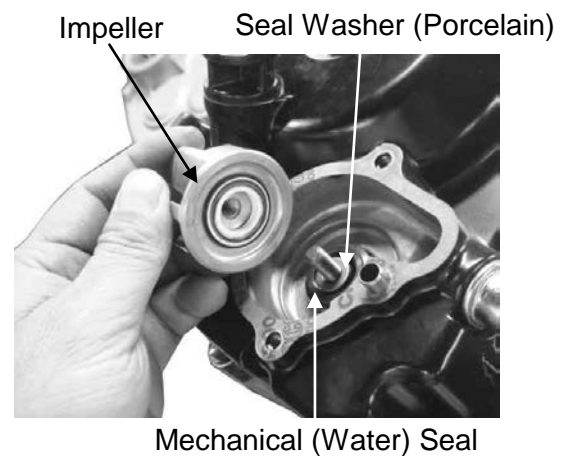

12. COOLING SYSTEM

THERMOSENSOR

THERMOSENSOR REMOVAL

Remove the met-in box and carrier.
Remove the body cover, center cover and rear fender cover A.

Drain the coolant.

Disconnect the thermosensor wire.

Remove the thermosensor.

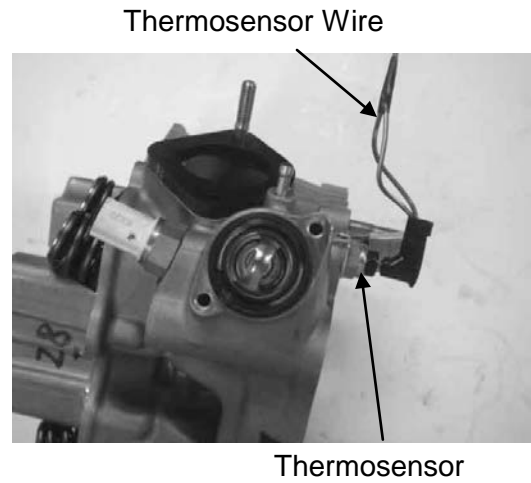

THERMOSENSOR INSPECTION

Suspend the thermosensor in a pan of water over a burner and measure the resistance through the sensor as the water heats up.

Temperature(°C)	50	80	100	120
Resistance(Ω)	154	52	27	16

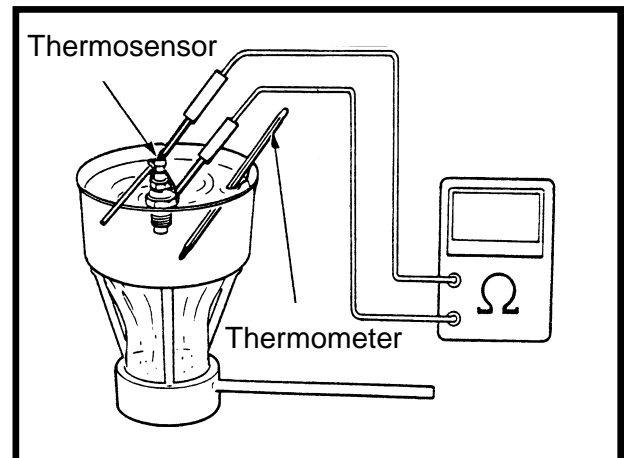

12. COOLING SYSTEM

THERMOSTAT

THERMOSTAT REMOVAL

Remove the met-in box and carrier.
Remove the body cover, center cover and rear fender cover A.

Drain the coolant.

Disconnect the thermosensor wire from the thermostat.

Disconnect the water hose from the thermostat housing.

Disconnect the air vent tube from the thermostat housing.

Remove the mounting bolt and the thermostat housing from the cylinder head.

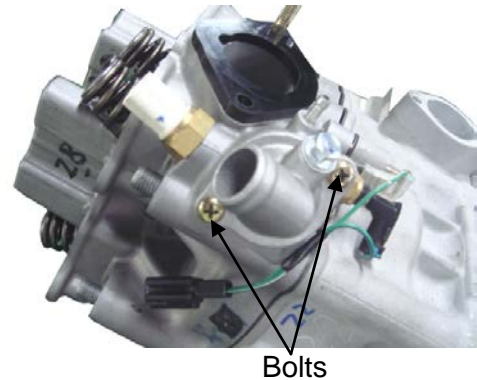

Remove two bolts and separate the thermostat housing halves.

Remove the thermostat from the thermostat housing.

THERMOSTAT INSPECTION

Suspend the thermostat in a pan of water over a burner and gradually raise the water temperature to check its operation.

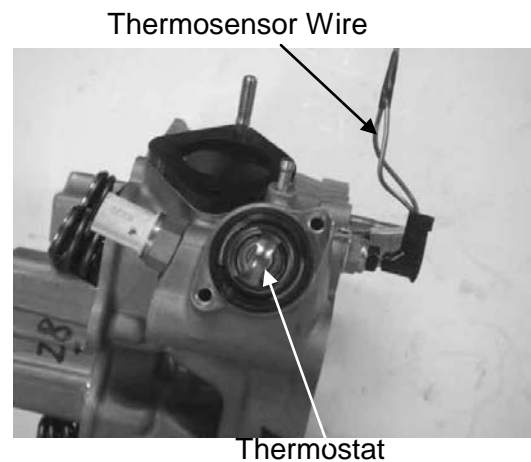

Technical Data

Begins to open	71 °C
Full-open	80 °C
Valve lift	3.5~4.5mm

- * Do not make the thermostat touch the pan as it will give a false reading.
- * Replace the thermostat if the valve stays open at room temperature.
- * Test the thermostat after it is opened for about 5 minutes and holds the temperature at 70°C.

THERMOSTAT INSTALLATION

- * Replace the O-ring with a new one and apply grease to it.

Fill the cooling system with the specified coolant.

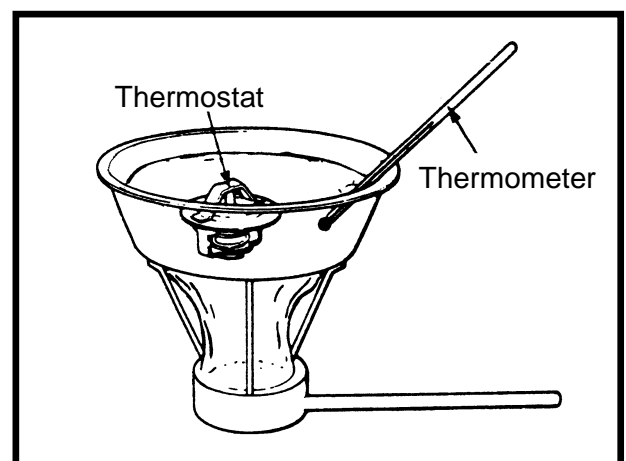

FUEL INJECTION SYSTEM

SERVICE INFORMATION.....	2
SPECIFICATIONS	3
INJECTION SYSTEM DIAGRAM	4
PARTS LOCATION.....	5
TROUBLESHOOTING	6
DTC LIST.....	7
SPARK PLUG ANTI-FLOOD.....	9
FUEL PUMP.....	10
FUEL CUT-OFF RELAY	12
TILT SWITCH	13
ECU REMOVAL/INSTALLATION	14
ECU PIN FUNCTION	15
FUEL INJECTOR	16
WTS SENSOR (Water.....	18
Temperature Sensor).....	18
O ² SENSOR.....	19
THROTTLE BODY/MAP/ISC/TPS	20
TPS INSPECTION	21
DIAGNOSTIC TOOL CONNECTOR	23
FI DIAGNOSTIC TOOL OPERATION INSTRUCTIONS	24
Diagnostic report.....	38

SERVICE INFORMATION

GENERAL INSTRUCTIONS

- Scooter services can be done with the engine installed in the frame.
- Be sure to relieve the fuel pressure before fuel pump or fuel hose removal.
- Bending or twisting the control cables will affect operation and could cause the cables to stick or bind, resulting in loss of vehicle control.
- Work in a fully ventilated area. Smoking or allowing flames or sparks in the work area or where gasoline is stored can cause a fire or explosion.
- Do not snap the throttle valve from fully open to fully close after the throttle cable has been removed; it may cause incorrect idle speed.
- Do not loosen or tighten the painted bolts and screws of the throttle body. Loosening or tightening them can cause throttle and idle valve synchronization failure.
- Seal the cylinder head intake ports with tape or a clean towel to prevent dirt and debris from entering the intake ports after the throttle body has been removed.
- Do not damage the throttle body. It may cause incorrect throttle and idle valve synchronization.
- Do not take the fuel pump on the ground downward.
- Always replace the packing when the fuel pump is removed.
- A faulty AFI problem is often related to poorly connected or corroded connectors. Check those connections before proceeding.
- When disassembling the fuel injection parts, note the location of the O-rings. Replace them with new ones upon reassembly.
- Do not disconnect the battery negative (-) or positive (+) cable while engine is running, it may cause ECU damage.
- **Do not disconnect or connect the ECU connector during the ignition switch “ON”; it may Cause to the ECU damage.**

SPECIFICATIONS

ITEM		SPECIFICATIONS
Throttle body identification number		AKC8
Idle speed		1600±100 rpm
Throttle grip free play		2~6 mm (1/16~1/4 in)
Fuel injector resistance (at 20°C/68°F)		11.7±0.6 Ω
Fuel pump resistance (at 20°C/68°F)	Float at full position	100±3 Ω
	Float at empty position	1100±33 Ω
Fuel pump standard pressure (at 40 L/Hr)		294±6 kPa (3 Bar)
Water temperature sensor resistance	At -20°C/-4°F	18.8 KΩ
	At 40°C/104°F	1.136 KΩ
	At 100°C/212°F	0.1553 KΩ
Intake pressure sensor (MAP) pressure (at 1 ~ 4.2 V)		13.332 kPa (0.13332 kgf/ cm ² , 1.89 psi) ~ 119.99 kPa (1.1999 kgf/ cm ² , 17.04 psi)
Inductive ignition coil		Primary: 3.57~4.83 Ω Secondary: 10.42~14.49K Ω
Throttle position sensor (TPS) resistance (at 20°C/68°F)		3500~6500 Ω
Crank position sensor voltage (at 200 rpm)		100~130 Ω
O ₂ heater sensor resistance (at 20°C/68°F)		6.7~9.5 Ω (engine warming condition)
Tilt switch voltage	Standard	0.4~1.4 V
	Over 65° (fall down)	3.7~4.4 V

INJECTION SYSTEM DIAGRAM

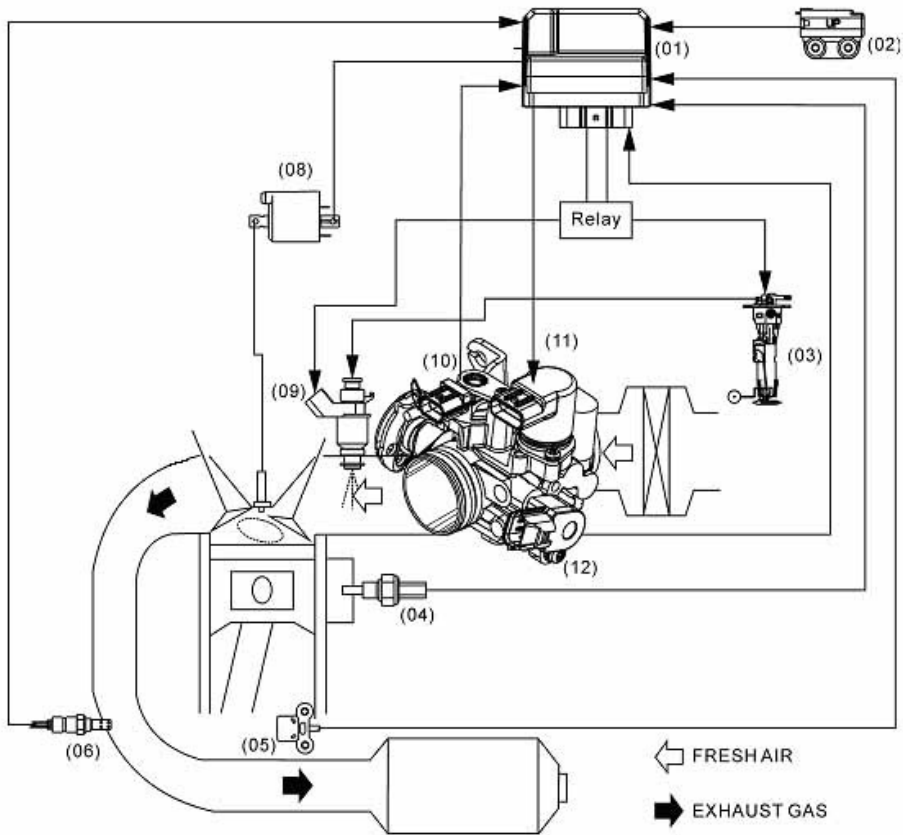

No.	FULL NAME	ABBREVIATIONS
(01)	Electronic control unit	ECU
(02)	Tilt switch (Angle detect sensor)	ROLL
(03)	Fuel pump/Fuel level unit	FP
(04)	Water temperature sensor	WTS sensor
(05)	Crank position sensor (Pulser)	CPS
(06)	Oxygen/Oxygen heater sensor	O ² /O ² Heat sensor
(08)	Inductive ignition coil	IG
(09)	Fuel injector (Nozzle)	INJ
(10)	Intake pressure sensor	MAP sensor
(11)	Idle air bypass valve	ISC
(12)	Throttle position sensor	TPS

PARTS LOCATION

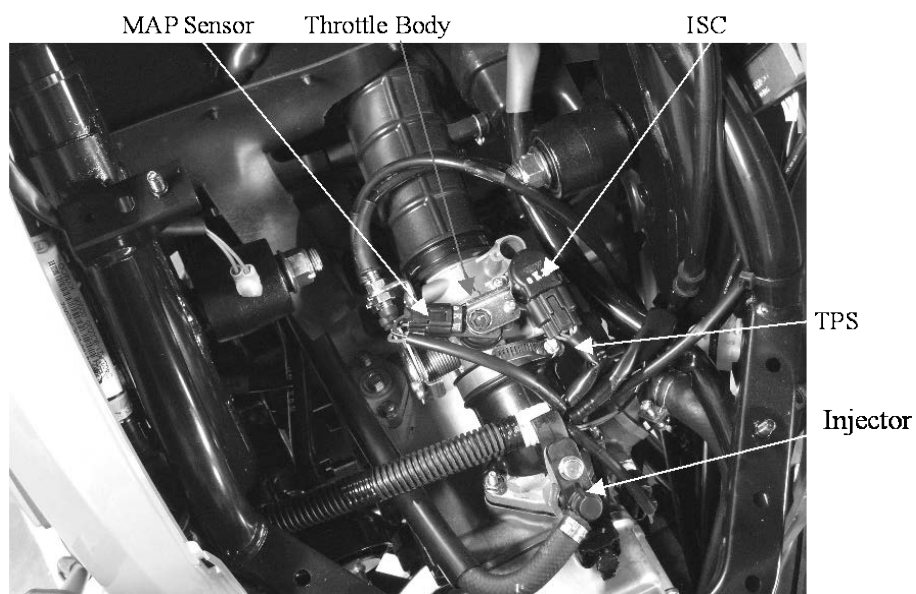
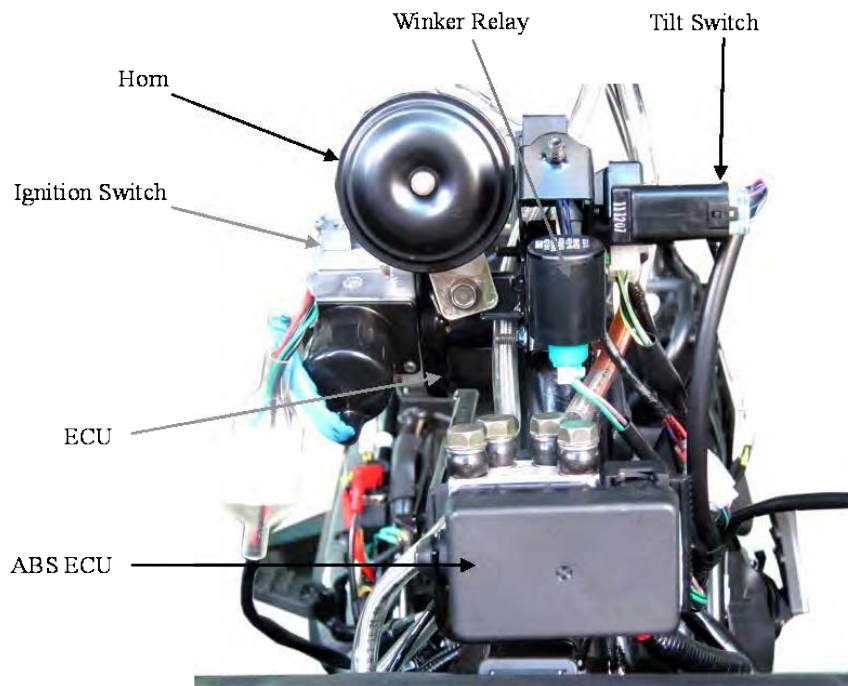

TROUBLESHOOTING

Engine fail to start

- Intake manifold air leak
- Fuel contaminated/deteriorated
- Pinched or clogged fuel hose
- Faulty fuel pump
- Clogged fuel filter, throttle body
- Sticking fuel injector needle
- Faulty fuel pump operating system
- Carbon deposit stayed on the fuel injector
- Spark plug dirty
- Fuel pressure incorrect

Engine stall, hard to start, rough idling

- Intake air leak
- Fuel contaminated/deteriorated
- Pinched or clogged fuel hose
- Idle speed fail to adjust
- Fail to perform PTS/ISC reset

Backfiring or misfiring during acceleration

- Ignition system malfunction

Poor performance (drive ability) and poor fuel economy

- Pinched or clogged fuel hose
- Faulty injector

13. FUEL INJECTION SYSTEM

DTC LIST

DTC	Item	Engine condition
P0335	Crank position sensor	Stop
P0120	Throttle position Sensor	Running
P0123		
P0107	MAP sensor	Running
P0105		
P0117	Water Temperature Sensor	Running
P0115		
P0112	Intake air temperature sensor	Running
P0110		
P2228	PA(Atmospheric Pressure) sensor	Running
P2226		
P1630	Rollover sensor	Stop
P0500	Rear Vehicle speed Sensor	Running
P2158		
P0500	Front Vehicle speed Sensor2	Running
P2158		
P0131	O2 sensor	Running
P0130		
P1659	Ignition power input	Stop
P0560	Battery Backup voltage input	Stop
P0201	Injector	Stop
P0351	Ignition coil	Stop
P0030	O2 sensor heater	Running
P0032		

13. FUEL INJECTION SYSTEM

DTC	Item	Engine condition
P0036	Sec-O2 sensor heater	Running
P0038		
P1698	Sensor power	Stop
P0230	Fuel pump relay	Stop
P0480	Radiator fan relay	Running
P0511	Idle Speed Control stepper motor	
P0412	Exhaust air injection	Running
P044F		
P06B8	EEPROM	Running
P1690	CAN	
P0301	Misfire	Running
P0420	Catalyst	
P0134	O2 sensor Out of range	Running
P0133	O2 Sensor deterioration	
P0053	O2 sensor heater Deterioration	Running
P0140	Sec-O2 Sensor deterioration	
P0139		
P0054	Sec-O2 sensor heater deterioration	Running
P0068	PM-TPS error Engine Load correlation	Running
P0069	PM/PA correlation error	
P011B	TW(water temperature)/TA(air temperature) correlation error	Running
P0125	TW(Water Temperature) Sensor increasing stuck	
P050C	TW Sensor decreasing stuck	Running
P16C0	Soak timer IC	
P0507	Idle air system	Running
P0506		
P0171	Fuel system	Running
P0172		

SPARK PLUG ANTI-FLOOD

When have not failure code occurs and pressing starter switch repeatedly, can still not start the engine, maybe the spark plug is wet by fuel, perform the spark plug anti-flood to purge the fuel in the engine.

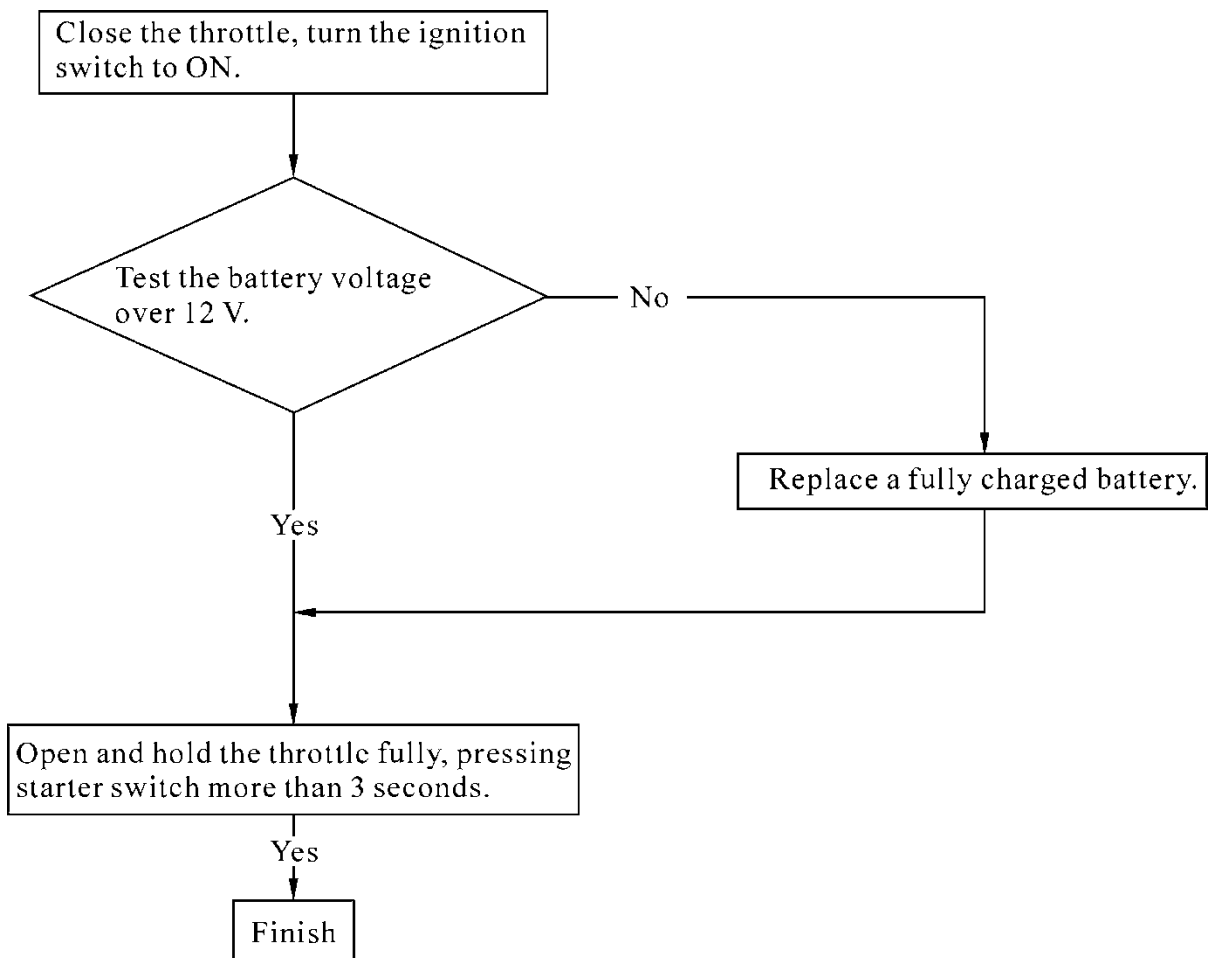

13. FUEL INJECTION SYSTEM

FUEL PUMP

INSPECTION

Put the side stand up and the engine stop switch is at "RUN"

Disconnect the fuel pump/fuel unit connector.

Connect the multimeter (+) probe to the Red/Black terminal and the multi-meter (-) probe to the Green terminal.

Turn the ignition switch to "ON" and measure the voltage between the terminals.

It should be shown the current battery voltage for a few seconds.

If there is still battery voltage, replace the fuel pump.

If there is not any battery voltage, inspect the following:

- Fuse B (10 A)
- Fuel cut-off relay
- ECU

Measure the resistance between the Red/Black and Green terminals of the fuel pump side connector.

Standard (at 20°C/68°F): 1.9±0.3 Ω

Fuel level sensor inspection

Measure the resistance between the Yellow/White and Green terminals of the fuel pump side connector.

Standard (at 20°C/68°F):

Float at full position	100±3 Ω
Float at empty position	1100±33 Ω

Connector

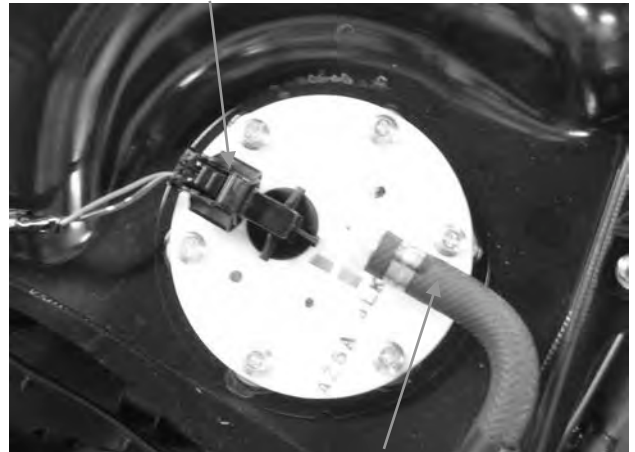

Fuel Hose

13. FUEL INJECTION SYSTEM

REMOVAL

Disconnect the connector and fuel band from the fuel pump.

Remove the six screws onto the fuel pump.

Remove the fuel pump and O-ring.

Fuel Pump Connector

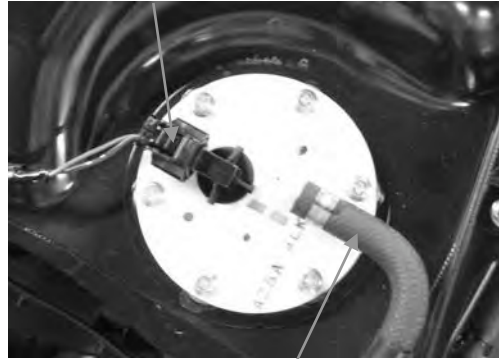

Hose Band

INSTALLATION

Replace a new O-ring on the fuel tank.

Don't damage the fuel pump wire and ensure the connector rearward carefully.

Torque: 0.35 kgf-m (3.5 N-m, 2.5 lbf-ft)



FUEL OUTPUT PRESSURE INSPECTION

Turn the key to the OFF position.

Use the fuel hose clamp.

Disconnect the fuel hose from the fuel injector.

Connect the fuel pressure gauge.

Turn the key to the ON position.

Check the fuel pressure.

Standard: 3.0 Bar

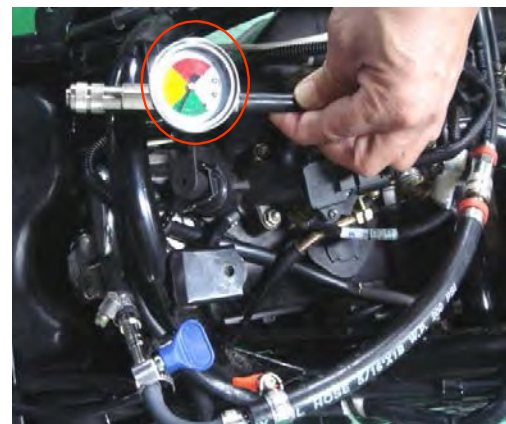

FUEL CUT-OFF RELAY

INSPECTION

Remove the fuel cut-off relay.
Connect the ohmmeter to the fuel cut-off relay connector terminals.

Connection: Black – Red/Black

Connect 12 V battery with the fuel cut-off relay connector.

Connection: Blue/Black – Black

There should be continuity only when 12 V battery connected.

If there is not continuity when the 12 V battery is connected, replace a fuel cut-off relay.

REMOVAL

Disconnect the fuel cut-off relay connector and remove it from frame.

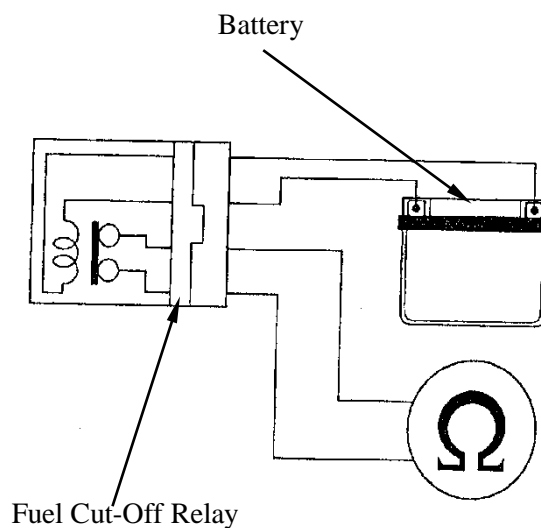

13. FUEL INJECTION SYSTEM

TILT SWITCH

INSPECTION

Support the scooter level surface.

Put the side stand up and engine stop switch is at "RUN".

Turn the ignition switch to "OFF"

Remove the screws, washers and tilt switch.

* Do not disconnect the tilt switch connector during inspection.

Place the tilt switch vertical as shown, and turn the ignition switch to "ON".

Measure the voltage between the following terminals of the tilt switch connector with the connector connected.

Terminal	Normal
Violet/Red (+) – Green/Pink (-)	5 V (ECU voltage)
Black/Blue (+) – Green/Pink (-)	0.4~1.4 V

Incline the tilt switch 65 ± 10 degrees to the left or right with the ignition switch turned to "ON".

Measure the voltage between the following terminals of the tilt switch connector with the connector connected.

Terminal	Normal
Violet/Red (+) – Green/Pink (-)	5 V (ECU voltage)
Black/Blue (+) – Green/Pink (-)	3.7~4.4 V

If repeat this test, first turn the ignition switch to "OFF", then turn the ignition switch to "ON".

REMOVAL/INSTALLATION

Disconnect the connector and remove two screws.

Remove the Tilt switch.

Installation is in the reverse order of removal.

* Install the tilt switch with its "UP" mark facing up.

Tighten the mounting screws securely.

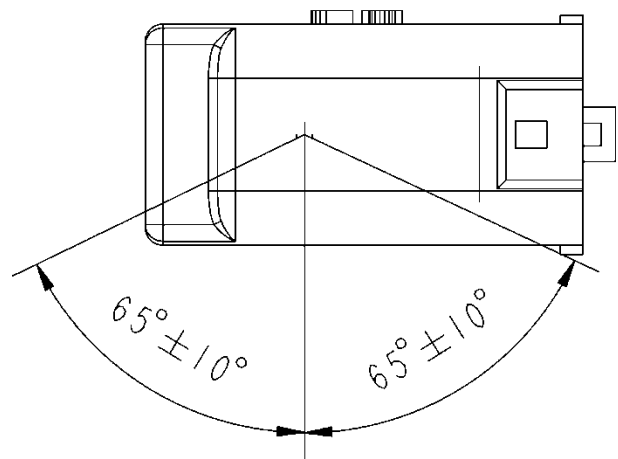
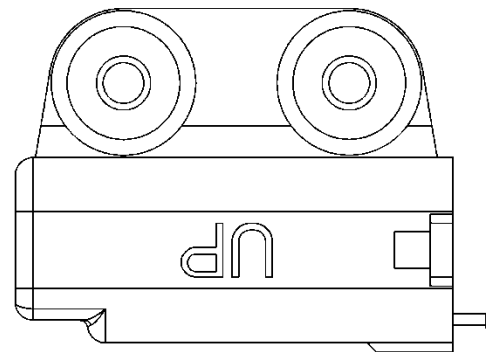

ECU REMOVAL/INSTALLATION

- * Do not disconnect or connect the ECU connector during the ignition switch "ON"; it may cause the ECU damaged.
- The throttle position sensor (TPS) and idle air bypass valve (ISC) have to be reset when throttle body, MAP, TPS, ISC or ECU has been reinstalled.

Disconnect the ECU connector and remove the ECU from the frame.

Installation is in the reverse order of the removal.

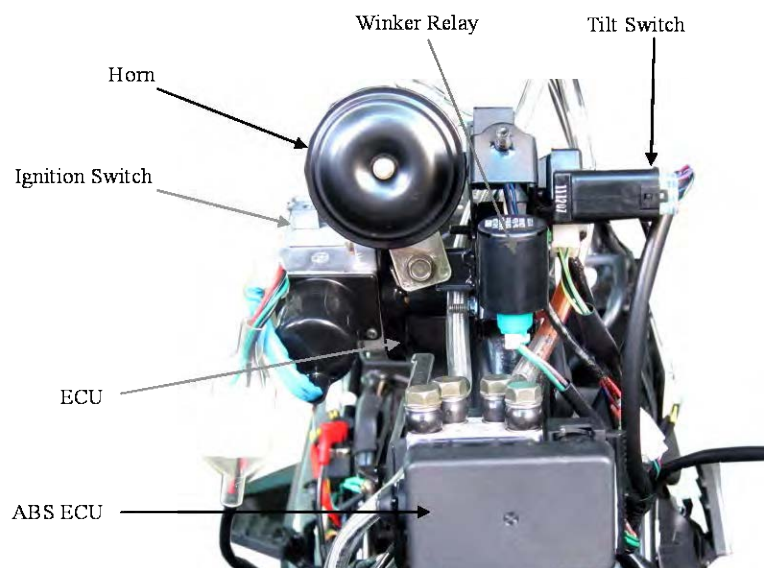

13. FUEL INJECTION SYSTEM



People S 300 ABS

ECU PIN FUNCTION

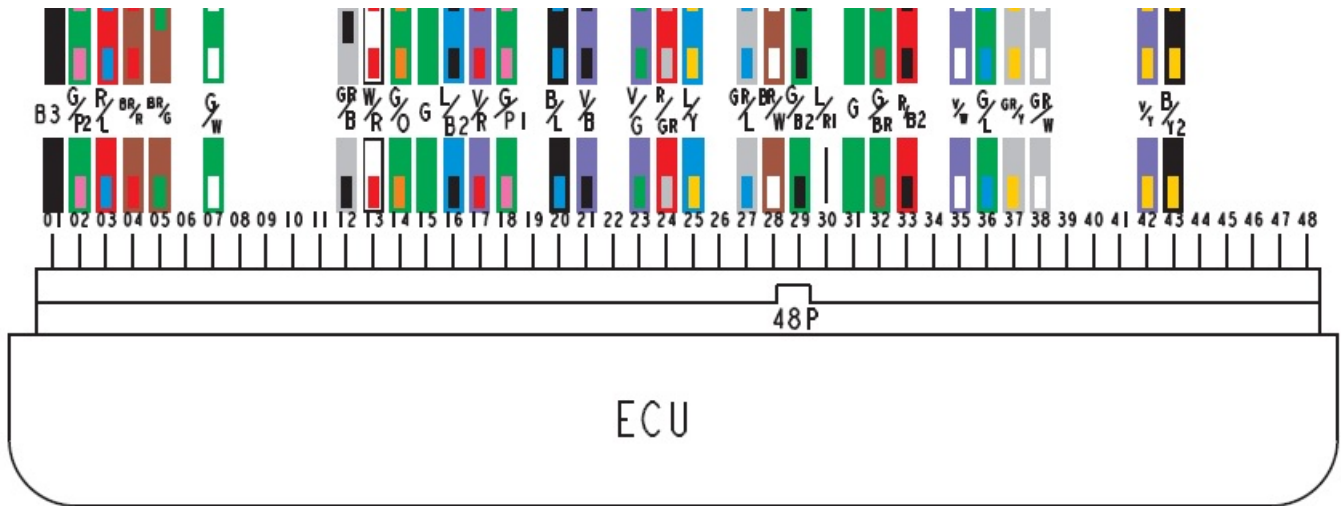

PIN NO.	NAME	FUNCTION	PIN NO.	NAME	FUNCTION	PIN NO.	NAME	FUNCTION
01	IGP	IGNITION POWER	19	SW_IN2	SWITCH INPUT 2:GND-OPEN	37	O2_F_GND	HEGO SENSOR FRONT GND INPUT
02	LG	LOGIC GROUND	20	ROLL	ROLL SENSOR	38	O2-F	HEGO SENSOR FRONT INPUT
03	FAN	FAN RELAY	21	TH	THROTTLE POSITION SENSOR	39	O2_R_GND	HEGO SENSOR REAR GND INPUT
04	CAN H	CAN HIGH	22	HEGO-R	HEGO SENSOR REAR INPUT	40	-	-
05	CAN L	CAN LOW	23	VSP2	VEHICLE SPEED SENSOR 2 INPUT	41	SW_IN4	SWITCH INPUT 4:GND-OPEN
06	OUT_IND1	INDICATOR OUTPUT 1	24	VSP1	VEHICLE SPEED SENSOR 1 INPUT	42	PA	ATMOSPHERIC PRESSURE SENSOR INPUT
07	CRK-M	CRANK PULSE SENSOR GND	25	CRK-P	CRANK PULSE SENSOR	43	PM	MANIFOLD PRESSURE SENSOR
08	SW_IN1	SWITCH INPUT 1:GND-OPEN	26	RLY_OUT1	RELAY OUTPUT 1	44	METER	METER OUTPUT
09	HEGO-HT_R	HEGO HEATER REAR OUTPUT	27	ISCBM	IDEL SPEED CONTROL / B	45	OUT_IND2	INDICATOR OUTPUT 2
10	-	-	28	ISCAN	IDEL SPEED CONTROL / A	46	RLY_OUT2	RELAY OUTPUT 2
11	-	-	29	ISCBP	IDEL SPEED CONTROL B	47	SOL_OUT1	SOLENOID OUTPUT 1
12	HEGO-HT_F	HEGO HEATER FRONT OUTPUT	30	MIL	MULTI INDICATOR LAMP	48	AISV	AIR INJECTION OUTPUT
13	INJ	INJECTION	31	PG2	POWER GROUND 2			
14	ISCAP	IDEL SPEED CONTROL A	32	IG	IGNITION COIL			
15	PG1	POWER GROUND 1	33	VBU	BACK UP VOLTAGE INPUT			
16	FLPR	FUEL PUMP RELAY	34	SW_IN3	SWITCH INPUT 3:GND-OPEN			
17	VCC	SENSOR POWER OUTPUT(+5V)	35	TA	AIR TEMP. SENSOR			
18	SG	SENSOR GROUND	36	TW	WATER TEMP. SENSOR			

13. FUEL INJECTION SYSTEM

FUEL INJECTOR

INSPECTION

Disconnect the fuel injector connector.
 Measure the resistance between 2 pins of the fuel injector connector.

Standard: $11.7 \pm 0.6 \Omega$ (at 20°C/68°F)

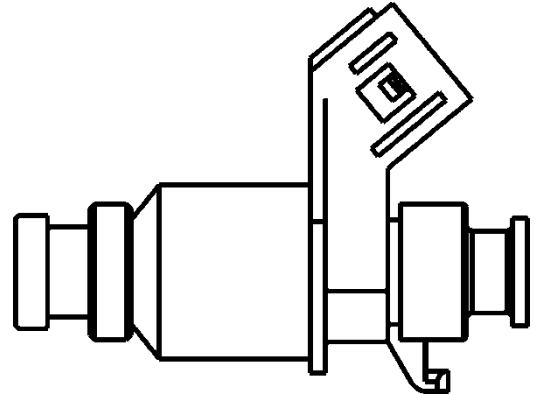

REMOVAL

Disconnect the connector from the fuel injector.
 Remove the bolt of the fuel injector.
 Take out of the fuel pipe and fuel injector from the Inlet pipe.
 Remove the fuel injector from the fuel pipe.

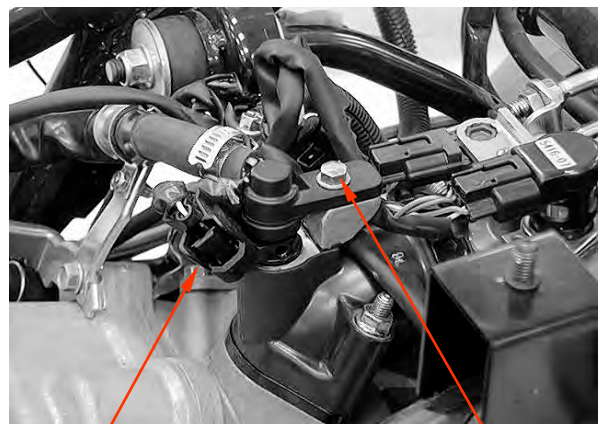

Connector

Bolt

*

Ensure the fuel pipe without any pressure, then remove the fuel injector.
STEP 1: Disconnect the fuel pump relay or fuel pump connector.
STEP 2: Turn the key to the ON position. Starting the engine till the engine stop working.

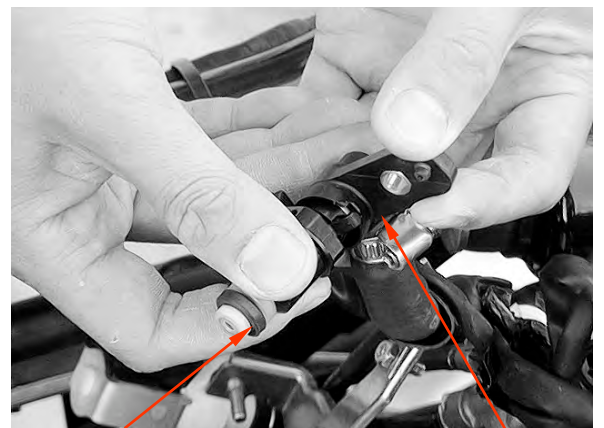

O-ring

Fuel Injector

13. FUEL INJECTION SYSTEM

INSTALLATION

Apply the engine oil to a new O-ring.
 Install the fuel injector into the fuel pipe.
 Ensure the tab of the fuel injector inserted into the groove of the fuel pipe.

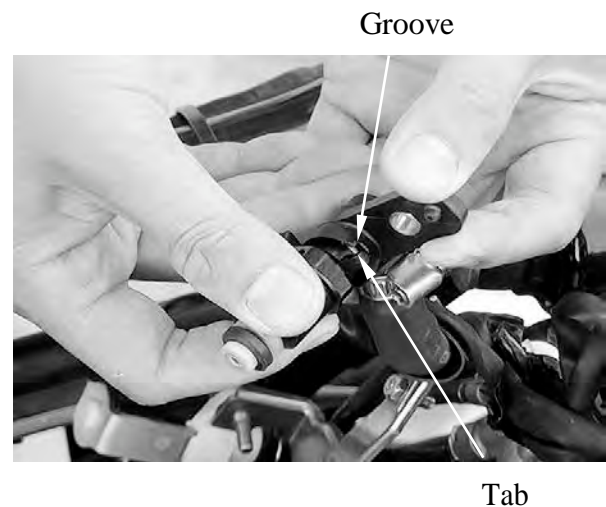

Install the fuel pipe into the intake manifold by aligning the dowel pin.
 Be careful not to damage the O-ring.
 Tighten the fuel pipe mounting bolt.



FUEL INJECTOR CLEANING

PROBLEM

1. Fuel Injector cannot output the fuel.
2. The Injector injection time (ms) is shorter or longer.

Standard: < 1.6ms

ANALYSIS

Injector block (With some carbons).

TROUBLESHOOTING

1. Use the specified injector cleaner.
2. Pouring the liquid of carburetor cleaner until half container.
3. Connect the battery as picture.
4. The injector cleaner with the flash relay.
5. Keeping the fuel Injector operation.
6. Waiting for 20~30 minutes.
7. Cleaning the carbons completely.

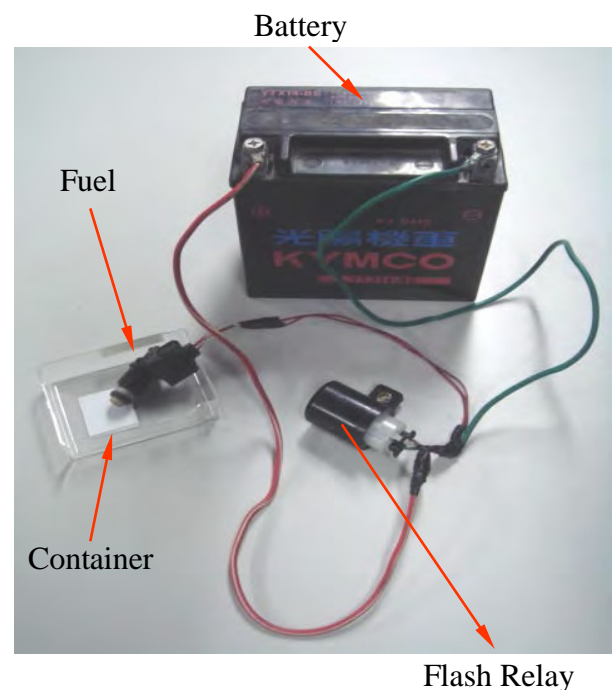

13. FUEL INJECTION SYSTEM

WTS SENSOR (Water Temperature Sensor)

REMOVAL / INSTALLATION

Drain the coolant from the cooling system.
 Disconnect the WTS sensor connector from the sensor.
 Remove the WTS sensor and O-ring.

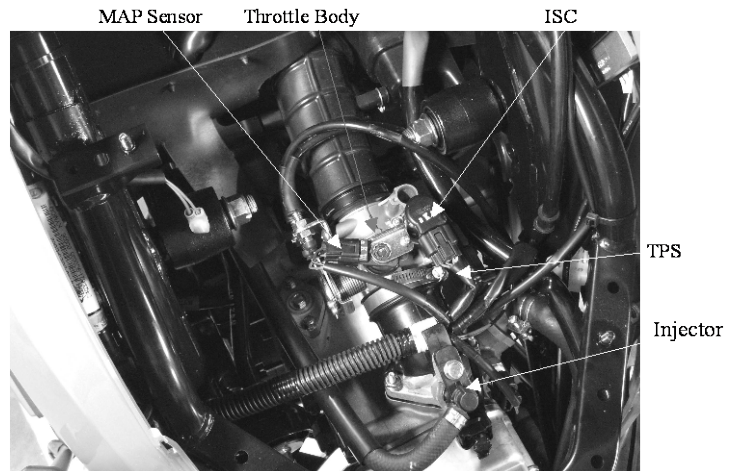

Install a new O-ring and WTS sensor.

* Always replace an O-ring with a new one.

Tighten the WTS sensor to the specified torque.

Torque: 1.2 kgf-m (12 N-m, 8.6 lbf-ft)

Connect the WTS sensor connector.

Fill the cooling system with the recommended coolant.

INSPECTION

Measure the resistance at the WTS sensor terminals.

STANDARD

°C	-20	40	100
KΩ	18.8	1.136	0.1553

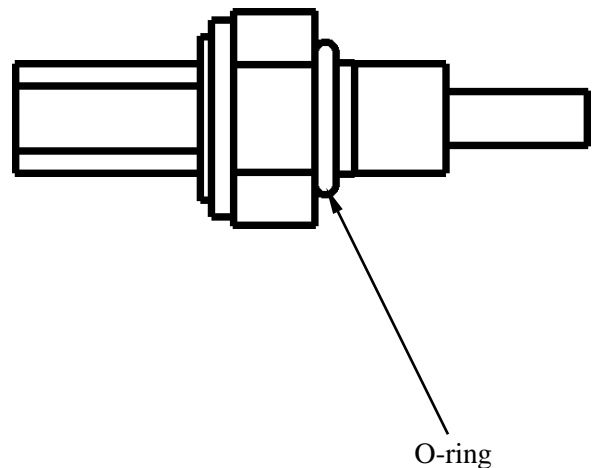

O² SENSOR

The O² sensor issues signal to ECU when the temperature is over 350°C during the engine is working.

The temperature is up to 350°C earlier than the muffler for O² heater sensor. So the O² sensor begins performance.

The function of O² sensor only controls the fuel injector operation.

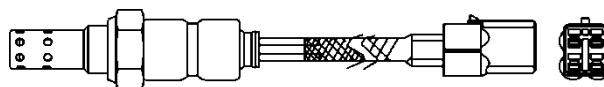

INSPECTION

Disconnect the O² sensor connector.

Measure the resistance between each White wire terminals of the O² sensor side connector.

Standard: 7.7±1.2 Ω (at 20°C/68°F)

REMOVAL/INSTALLATION

Disconnect the O² sensor connector and then remove it from exhaust muffler.

Installation is in the reverse order of removal.

* Apply anti-seize compound on the surface of thread area before O² sensor installation.

Tighten the O² sensor to specified torque.

Torque: 2.5 kgf-m (25 N-m, 18 lbf-ft)

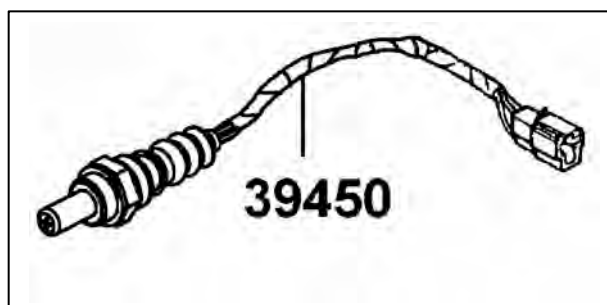

13. FUEL INJECTION SYSTEM

THROTTLE BODY/MAP/ISC/TPS

- Turn off the ignition switch while replacement.
- Check and confirm if the voltage is over 12V by a voltmeter after replacement.
- Check and confirm if the other connectors are installed correctly after replacement.
- Do not damage the throttle body, it may cause the throttle and idle valve isn't synchronization.
- The throttle body is preset in KYMCO factory, do not disassemble it by a wrong way.
- Do not loosen or tighten the painted bolts and screws for the throttle body. Loosen or tighten them can cause the throttle and idle valve to synchronization failure.
- **TPS and ISC have to be reset after the throttle body MAP, TPS, ISC or ECU has been reinstalled.**



MAP INSPECTION

Support the scooter on a level surface.

Put the side stand up and engine stop switch is at "RUN".

Turn the ignition switch to "ON" position.

Measure if the ECU voltage outputs to the MAP between the following terminals of the MAP connector.

Terminal	Normal
Violet/Red (+) – Green/Pink (-)	5 V

13. FUEL INJECTION SYSTEM

TPS INSPECTION

Support the scooter on a level surface.

Put the side stand up and engine stop switch is at "RUN".

Turn the ignition switch to "ON".

Measure if the ECU voltage outputs to TPS between the following terminals of the TPS connector.

Terminal	Normal
Violet/Red (+) – Green/Pink (-)	5 V

Throttle position sensor (TPS) resistance
(at 20°C/68°F) 3500~6500 Ω

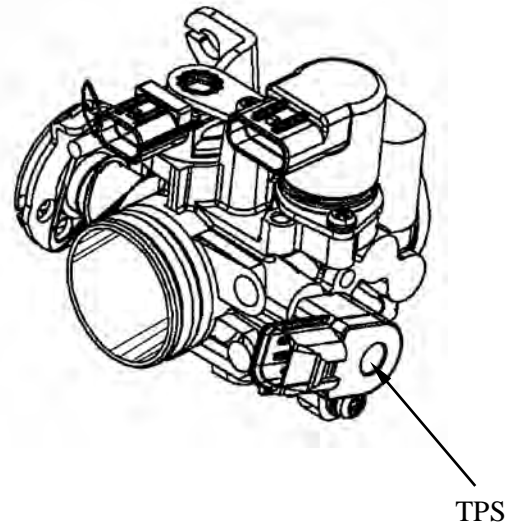

REMOVAL

Loosen the throttle cables with the adjusting nuts.

Disconnect the throttle cable ends from throttle seat.

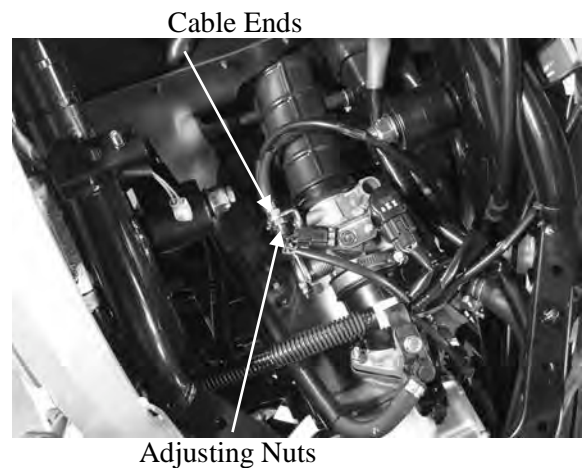

Disconnect the TPS, ISC and MAP sensor connectors.

Loosen the air cleaner connecting hose band screw.

Loosen the intake manifold band screw.

Remove the throttle body, MAP sensor, TPS sensor and ISC sensor as a set.

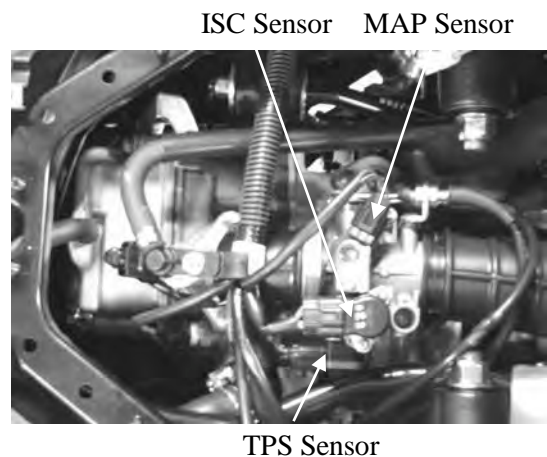

13. FUEL INJECTION SYSTEM

DISASSEMBLY

*

The throttle position sensor (TPS) and idle air bypass valve (ISC) have to be reset when the throttle body MAP, TPS, ISC or ECU has been reinstalled.

Remove the screw and then remove the ISC and set plate.

Remove the screw and set plate.

Remove the MAP

Remove the screw AND then remove the TPS.

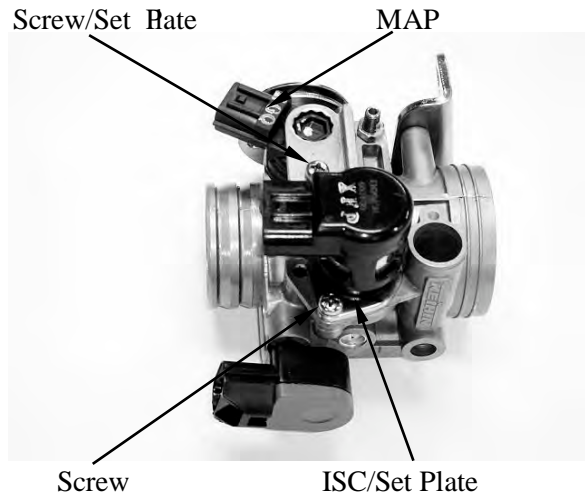

ASSEMBLY

*

The throttle position sensor (TPS) and idle air bypass valve (ISC) have to reset when the throttle body MAP, TPS, ISC or ECU has been reinstalled.

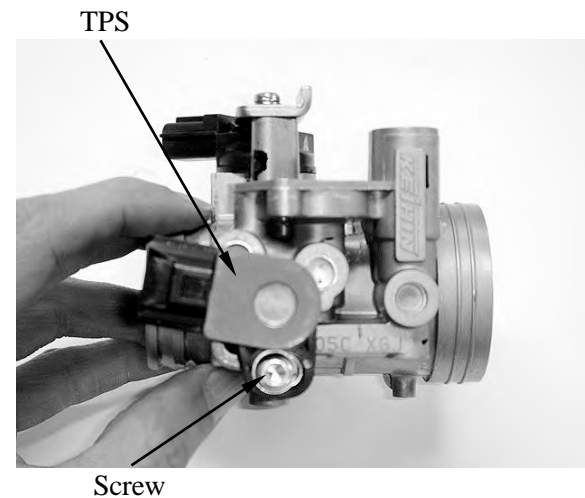

Apply oil onto a new O-ring.

When install the TPS onto the throttle body, being careful not to damage the O-ring.

Install and tighten the screw securely.

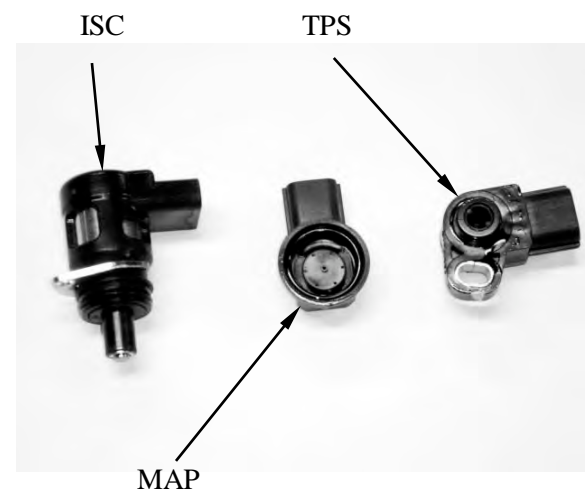

13. FUEL INJECTION SYSTEM

Apply oil onto a new O-ring.

When install the MAP onto the throttle body, being careful not to damage the O-ring.

* Always replace an O-ring with a new one.

Install the set plate and tighten the screw securely.

Apply oil onto a new O-ring.

When install the ISC and set plate onto the throttle body, being careful not to damage the O-ring.

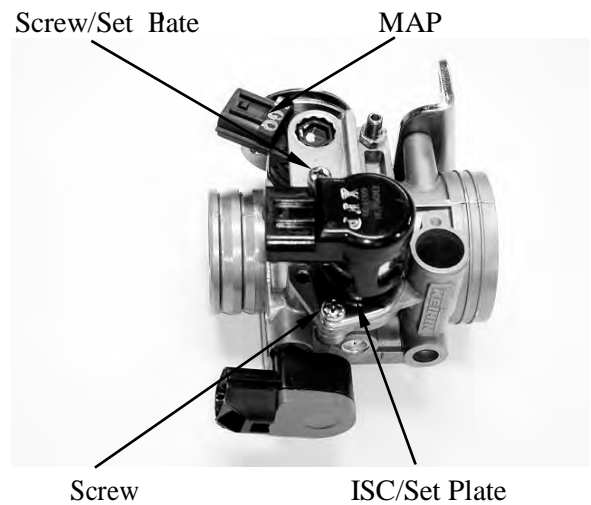
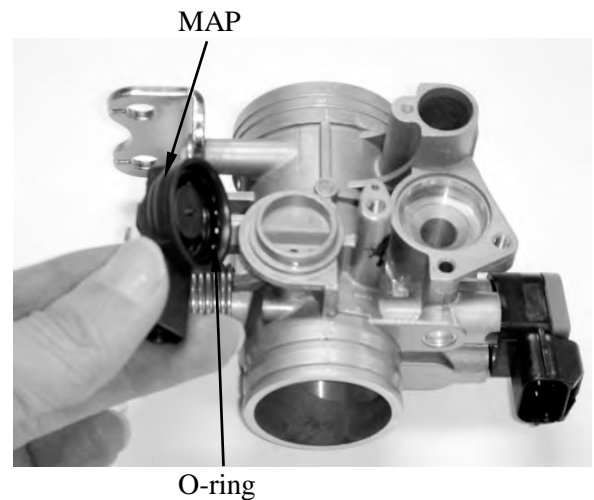

DIAGNOSTIC TOOL CONNECTOR INSPECTION

Put the side stand up and engine stop switch is at "RUN".
 Turn the ignition switch to "ON"
 Measure the voltage between the following terminals of the diagnostic tool connector with PDA tester.

Terminal	Normal
Black (+) – Green (-)	Battery voltage
White/Yellow (+) – Green (-)	Battery voltage -1 V



Diagnostic Connector



FI DIAGNOSTIC TOOL OPERATION INSTRUCTIONS 3620A-LEB2-E00

13. FUEL INJECTION SYSTEM

— FI DIAGNOSTIC TOOL

- This tool is developed by KYMCO and for KYMCO vehicle only.
- Please refer to the specification when serving this vehicle.
- This tool is without battery inside. The power is provided from vehicle.
- This software can be updated with computer for new model through the USB cable. The power required of tool is connected with 12V battery.
- For connection, please connect this tool with the connector of ECU. It's available when turning on the ignition switch.
- The side stand must be upward when serving the diagnostic procedure.
- The function includes ECU version, model name, data analysis and reset.
 - ECU version: includes model name, ECU number, identifications number and software version.
 - Failure codes: DTC reading, DTC clearing and troubleshooting.
 - Data analysis: For ECU's software inspection.
 - Reset: For the setting function adjustment.

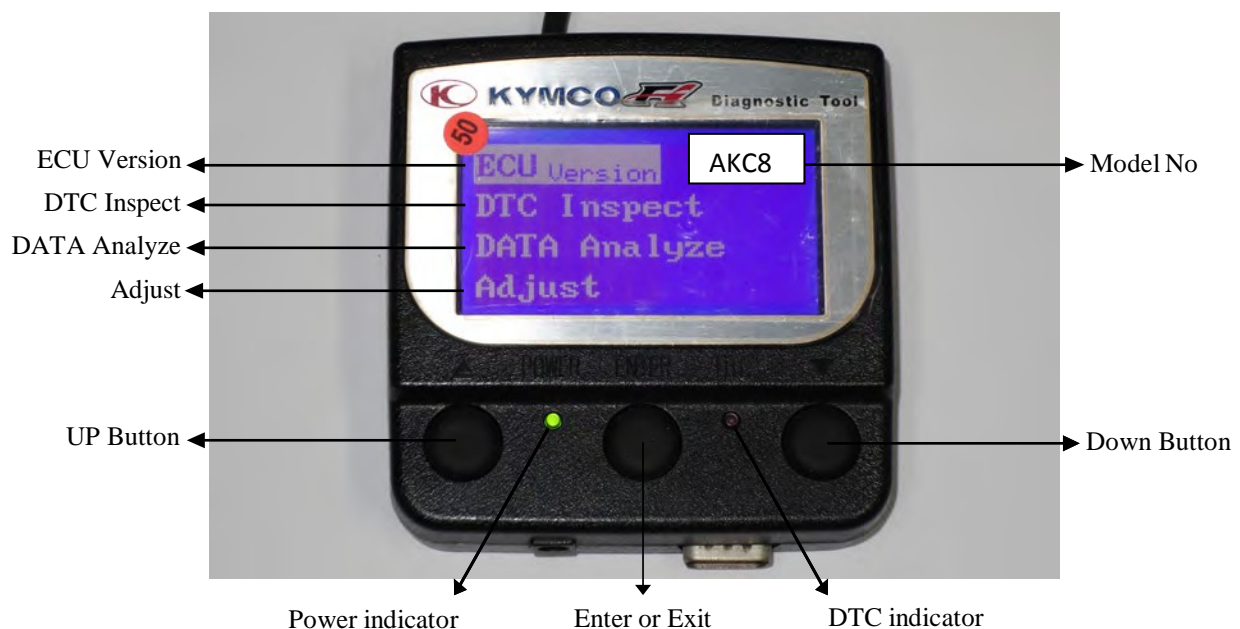

13. FUEL INJECTION SYSTEM

二. DTC INSPECTION PROCEDURE

Showing four functions on the screen when switching on power.



A). ECU version: Including of model name, ECU number, identifications number and software version.
Press the " Enter " button



13. FUEL INJECTION SYSTEM

B). Press the " Down " button and then turn to the first page.



C). Press the " Enter " button to check the DTC failure code



13. FUEL INJECTION SYSTEM

D). Press the " Enter " button



E). Press the " Enter " button



F). Display what's DTC number on this DTC-List.
Press the " Enter " button and then turn to the previous page



13. FUEL INJECTION SYSTEM

G). Press the " UP " button



H). Press the " Enter " button and then turn to the previous page with red color.



I). Press the " UP " button



13. FUEL INJECTION SYSTEM

J). Press the " Enter " button and then turn to the first page.



≡. DTC CLEAR PROCEDURE

A). Check the DTC



B). Press the " Enter " button



C). Choose " Load DTC " Press the " Down " button



D). Press the " Enter " button and the indicator is lighting.



E). Clearing DTC completed if the indicator is off.



四. DATA ANALYSIS PROCEDURE

A). Press the " Down " twice



B). Choose " Data Analyze"
Press the " Enter " button to enter page 01



C). Down-page 01

The measure figures including of Engine speed, Battery voltage and DTC number.
Press the " Down " button to enter page 02.



13. FUEL INJECTION SYSTEM

D). Down-page 02

The measure figures including of TPS position, Intake pressure and Intake air temperature.
Press the “Down” button to enter page 03.



E). Down-page 03

The measure figures including of Atmosphere pressure, Fuel Injector interval and Ignition advance timing.
Press the “Down” button to enter page 04.



F). Down-page 04

The measure figures including of Engine temperature, O2 sensor voltage and O2 heater activation.
Press the “Down” button to enter page 05.



13. FUEL INJECTION SYSTEM

G). Down-page 05

The measure figures including of ISC target, ISC step and ISC learn step.
Press the “ Down” button to enter page 06.



H). Down-page 06

The measure figures including of ISC motor state. Press the “ Down” button to enter page 07.



I). Down-page 07

The measure figures including of Cut Out voltage.



J). Press the " UP " to the previous page.

五. Vehicle cannot be started – Handling method (Steps)

Preliminary Checking: 6 basic inspection

Is the battery with voltage (12 V or higher)

Key-On and listen for any action with Fuel Pump / Fuel Pump Relay (It will turn off automatically in 2-3 seconds)

Key-On to check for any failure lamp light up on dashboard.

Is the Idle screw of Throttle Valve being changed or loose?

Has the vehicle under regular service? Is the gas station a good one?

Is the spark plug the correct model of specified by the vehicle builder?

13. FUEL INJECTION SYSTEM

Diagnostic report

	Item	Specification	Actual parameter	Remark
Certificati on Ver.	Software Version	KYA02TW211100502		
	Calibration Identify code	E5AKC8EUAA		
	Model Name	AKC8		
DTC	Active			
	Occurred			
	History			
(Cool Engine) Engine Stop	Throttle Position(%)	< 1.00%		Full Throttle >92%
	Throttle Position Voltage (V)	0.60±0.02 V		Full Throttle Voltage 3.7~4V
	Engine Temp.(°C)	℃		The Fanner's run and stop should be more than two times at Engine Temp. 94°C.
	Atom. Temp.(°C)	environ.temp ± 5°C		
	Atom. Pressure(Kpa)	101.3 ± 3 kPa		
	Battery Voltage(V)	>12 V		
	Roll Sensor State	OFF		Fall down indicated ON
	Roll Sensor Signal	Stand 0.8±0.3V		Fall down >3.9V
	Spark plug Type	CR7E		
(Hot Engine) Before Repair	IDLE (rpm)	1620 ± 100 rpm		Engine Temp. 85°C
	Intake Pressure(Kpa)	30~39 kpa		
	Engine Temp.(°C)	℃		The Fanner's run and stop should be more than two times at Engine Temp. 94°C.
	Atom. Temp.(°C)	environ.temp.		
	Fuel Inject Interval(ms)	2 ~ 3 ms		Engine Temp. 85°C
	Ignition Timing (°)	7 ~ 15 BTDC		
	Battery Voltage(V)	>13 V		
	O2 Sensor Voltage(V)	1.5 ~ 2.5 V		Under Engine running
	O2 heater state	ON		
	ISC Step	90 ± 20		Engine Temp. 85°C
IDLE CO(%))	0.3 ~ 1.5%		before catalyst	
CO correct volume	0.85 ~ 1.2			
(Hot Engine) After Repair	IDLE (rpm)	1620 ± 100 rpm		Engine Temp. 85°C
	Intake Pressure(Kpa)	30~39 kpa		
	Engine Temp.(°C)	℃		The Fanner's run and stop should be more than two times at Engine Temp. 94°C.
	Atom. Temp.(°C)	environ.temp.		
	Fuel Inject Interval(ms)	2 ~ 3 ms		Engine Temp. 85°C
	Ignition Timing (°)	7 ~ 15 BTDC		
	Battery Voltage(V)	>13 V		
	O2 Sensor Voltage(V)	1.5 ~ 2.5 V		Under Engine running
	O2 heater state	ON		
	ISC Step	90 ± 20		Engine Temp. 85°C
IDLE CO(%))	0.3 ~ 1.5%		before catalyst	
CO correct volume	0.85 ~ 1.2			

**14. STEERING HANDLEBAR/FRONT WHEEL/FRONT
BRAKE/FRONT SHOCK ABSORBER/FRONT FORK**



People S 300 ABS

**STEERING HANDLEBAR/FRONT WHEEL/FRONT
BRAKE/FRONT SHOCK ABSORBER/FRONT FORK**

SCHEMATIC DRAWING	14- 1
SERVICE INFORMATION	14- 2
TROUBLESHOOTING	14- 3
STEERING HANDLEBAR	14- 4
FRONT WHEEL	14- 5
FRONT BRAKE.....	14- 8
FRONT SHOCK ABSORBER	14-12
FRONT FORK.....	14-13

14. STEERING HANDLEBAR/FRONT WHEEL/FRONT BRAKE/FRONT SHOCK ABSORBER/FRONT FORK



People S 300 ABS

SCHEMATIC DRAWING

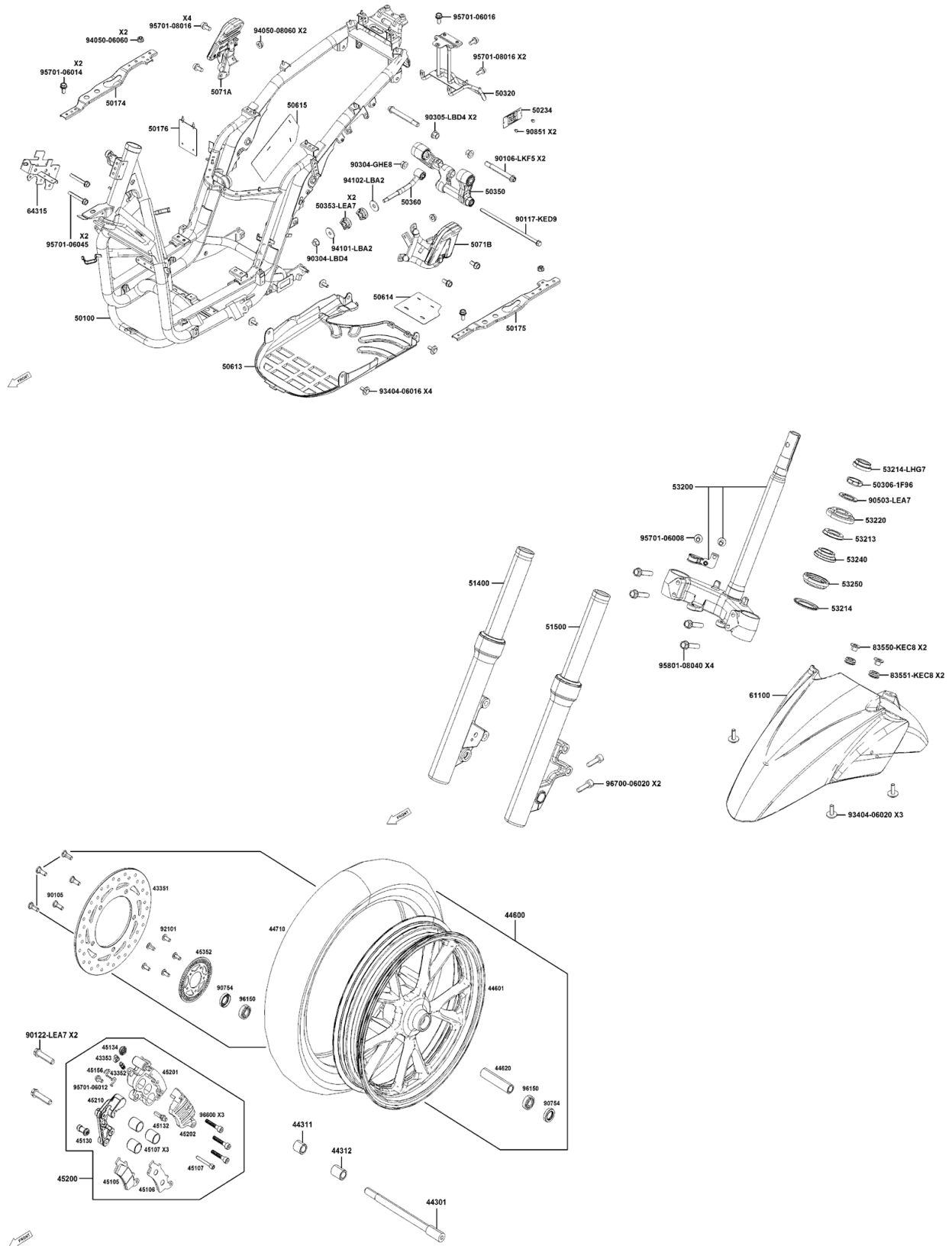

14. STEERING HANDLEBAR/FRONT WHEEL/FRONT BRAKE/FRONT SHOCK ABSORBER/FRONT FORK



People S 300 ABS

SERVICE INFORMATION

GENERAL INSTRUCTIONS

- Remove the motorcycle frame covers before removing the front wheel, steering handlebar, front shock absorber and front fork. Jack the motorcycle front wheel off the ground and be careful to prevent the motorcycle from falling down.
- During servicing, keep oil or grease off the brake pads and brake disk.

SPECIFICATIONS

Item		Standard (mm)	Service Limit (mm)
Axle shaft runout		—	0.2
Front wheel rim runout	Radial	—	2.0
	Axial	—	2.0
Brake disk thickness		5.0	4.0
Brake disk runout		—	0.30
Brake caliper piston O.D.		25.33~25.36	25.3
Brake caliper cylinder I.D.		25.4~25.45	25.45
Brake master cylinder O.D.		13.95~13.98	13.95
Brake master cylinder I.D.		14.0~14.04	14.05

TORQUE VALUES

Steering Handle Post Bolt	45 N-m
Steering Stem Lock	63 N-m
Steering Head Race Nut	20 N-m
Rear Suspension Bolt	27 N-m
Front Axle Nut	120 N-m
Brake caliper holder bolt	35 N-m

SPECIAL TOOLS

Lock Nut Wrench	F002
Oil seal & Bearing Driver	E014

TROUBLESHOOTING

Hard steering (heavy)

- Excessively tightened steering stem top cone race
- Broken steering balls
- Insufficient tire pressure

Steers to one side or does not track straight

- Uneven front shock absorbers
- Bent front fork
- Bent front axle or uneven tire

Poor brake performance

- Worn brake pads
- Contaminated brake pad surface
- Deformed brake disk
- Air in brake system
- Deteriorated brake fluid
- Worn brake master cylinder piston oil seal
- Clogged brake fluid line
- Unevenly worn brake caliper

Front wheel wobbling

- Bent rim
- Loose front axle
- Bent spoke plate
- Faulty tire
- Improperly tightened axle nut

Soft front shock absorber

- Weak shock springs
- Insufficient damper oil

Front shock absorber noise

- Slider bending
- Loose fork fasteners
- Lack of lubrication

14. STEERING HANDLEBAR/FRONT WHEEL/FRONT BRAKE/FRONT SHOCK ABSORBER/FRONT FORK

STEERING HANDLEBAR

REMOVAL

Remove the handlebar front and rear covers.
(⇒2-3)
Remove the front and rear brake master cylinder attaching bolts.

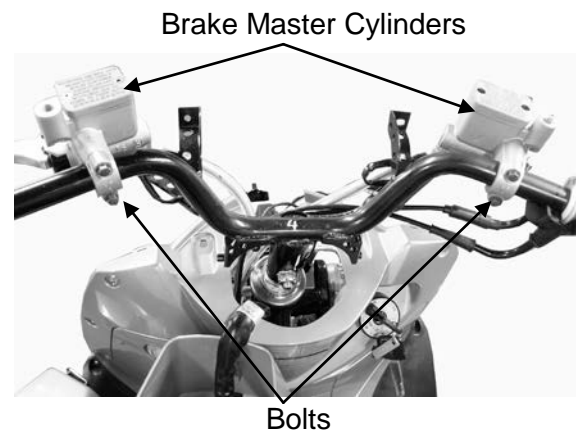

Remove the four screws attaching the right and left handlebar switches.
Disconnect the throttle cable from the throttle grip and remove the throttle grip from the handlebar.

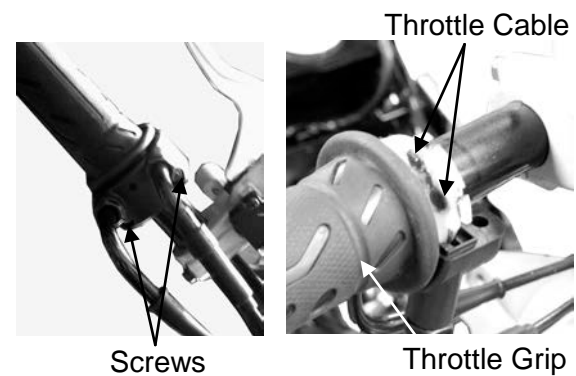

Remove the handlebar lock nut, then take out the bolt and collar.
Remove the handlebar.

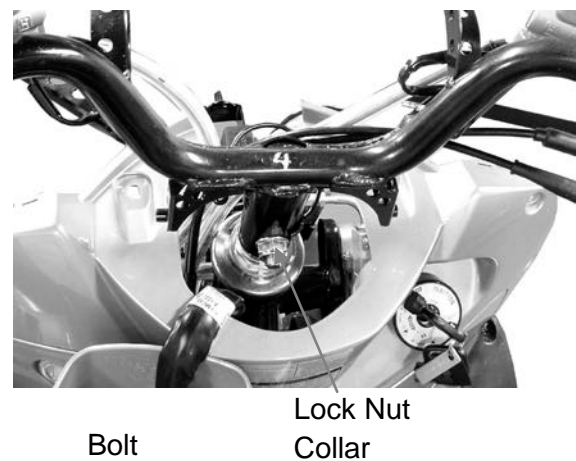

INSTALLATION

Install the handlebar onto the steering stem and install the handlebar collar, lock nut and bolt.
Tighten the handle post bolt to the specified torque.

Torque: 45 N-m



14. STEERING HANDLEBAR/FRONT WHEEL/FRONT BRAKE/FRONT SHOCK ABSORBER/FRONT FORK

Lubricate the throttle grip front end with grease and then install the throttle grip. Connect the throttle cable to the throttle grip. Install the right and left handlebar switches and tighten the screws.

- * Adjust the throttle grip free play to the specified range of 2~6mm.

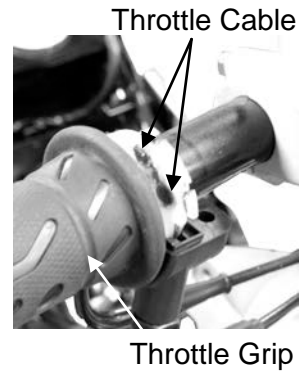

Install the front and rear brake master cylinders.

- * Install the brake master cylinders by aligning the index marks.



FRONT WHEEL REMOVAL

Disconnect the speed wire from the front right suspension unit. Remove the front axle to pull out the axle. Remove the front wheel.



INSPECTION

AXLE RUNOUT

Set the axle in V blocks and measure the runout using a dial gauge. The actual runout is $\frac{1}{2}$ of the total indicator reading.

Service Limit: 0.2 mm replace if over

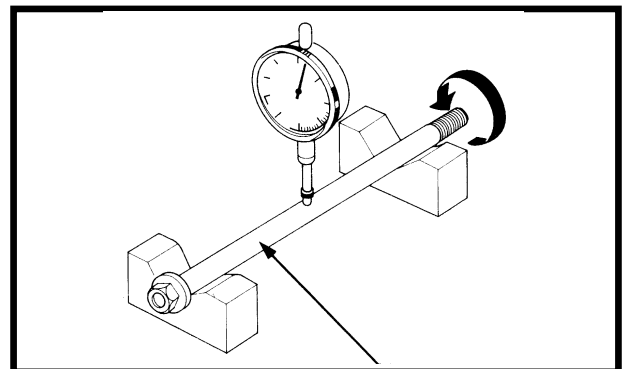

14. STEERING HANDLEBAR/FRONT WHEEL/FRONT BRAKE/FRONT SHOCK ABSORBER/FRONT FORK

WHEEL RIM

Check the wheel rim runout.

Service Limits:

Radial: 2.0 mm replace if over

Axial: 2.0 mm replace if over

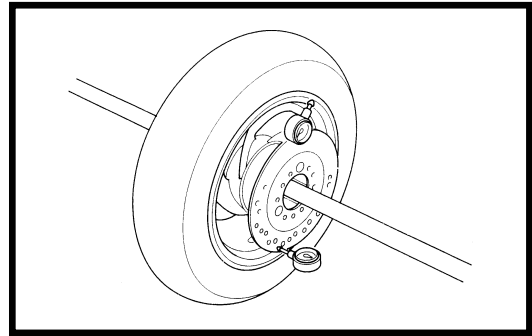

FRONT WHEEL BEARING

Remove the side collar and dust seal.



Turn the inner race of each bearing with your finger to see if they turn smoothly and quietly. Also check if the outer race fits tightly in the hub.

Replace the bearings if the races do not turn smoothly, quietly, or if they fit loosely in the hub.



BEARING REPLACEMENT

Remove the front wheel bearings and distance collar.

14. STEERING HANDLEBAR/FRONT WHEEL/FRONT BRAKE/FRONT SHOCK ABSORBER/FRONT FORK

Pack all bearing cavities with grease.
Drive in the left bearing.
Install the distance collar.
Drive in the right bearing.

- * • Do not allow the bearings to tilt while driving them in.
• Drive in the bearing squarely with the sealed end facing out.

Special Tools

Oil seal & Bearing Driver A120E00014



INSTALLATION

Insert the axle and tighten the axle bolt.

- * When installing the front wheel, take the brake disk among the two brake pads.

Torque: 20 N-m

Install the axle fixed hexagon bolt.

Torque : 23 N-m



FRONT BRAKE

BRAKE MASTER CYLINDER

REMOVAL

Remove the handlebar covers. (⇒2-3)
Drain the brake fluid from the hydraulic brake system.
Disconnect the front stop switch wire connector.
Remove the brake fluid tube bolt.
Remove two bolts attaching the brake master cylinder
Remove the brake master cylinder.



Holder

- * • When servicing the brake system, use towels to cover rubber and plastic parts and coated surfaces to avoid being contaminated by brake fluid.
- When removing the brake fluid tube bolt, be sure to plug the tube end to avoid brake fluid leakage.

DISASSEMBLY

Remove the brake lever bolt and the brake lever.
Remove the piston rubber cover and snap ring from the brake master cylinder.

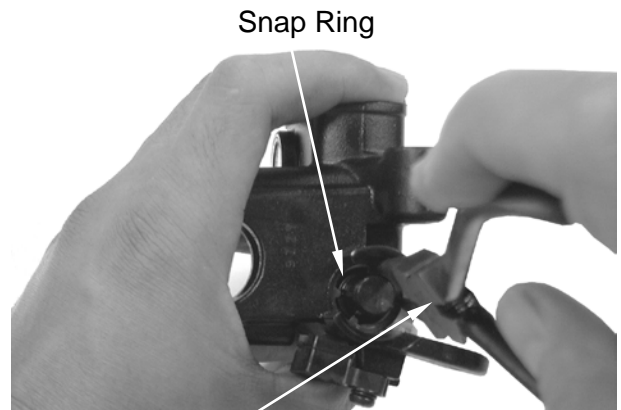

Snap Ring

Snap Ring Pliers (Close)

Master Cylinder Spring Main Piston

Remove the washer, main piston and spring from the brake master cylinder.
Clean the inside of the master cylinder and brake reservoir with brake fluid.

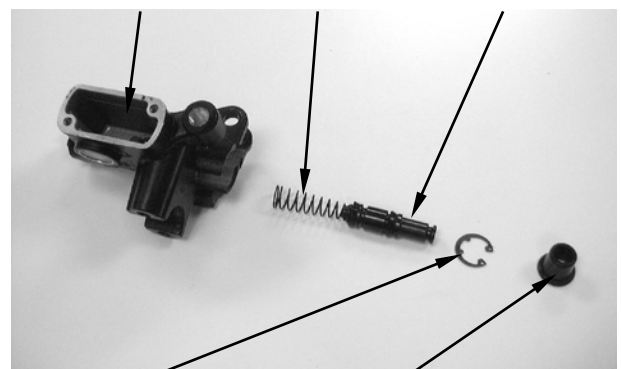

Snap Ring

Rubber Cover

14. STEERING HANDLEBAR/FRONT WHEEL/FRONT BRAKE/FRONT SHOCK ABSORBER/FRONT FORK

INSPECTION

Measure the brake master cylinder I.D.
Inspect the master cylinder for scratches or cracks.

Service Limit: 14.05 mm

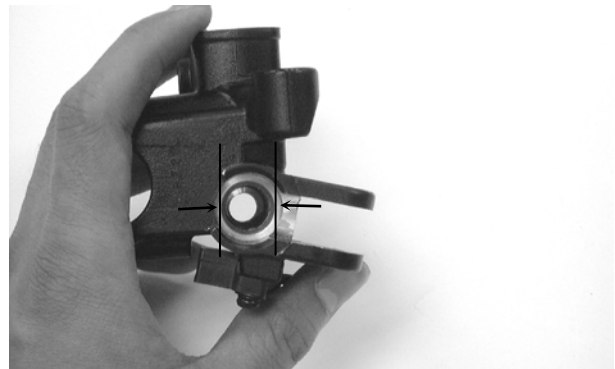

Measure the brake master cylinder piston O.D.

Service Limit: 13.94 mm

Before assembly, inspect the 1st and 2nd rubber cups for wear.

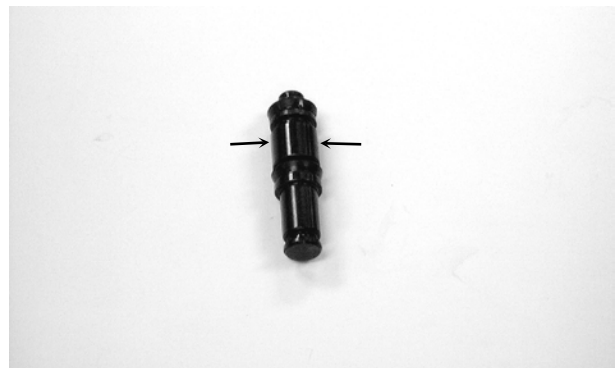

ASSEMBLY

Before assembly, apply brake fluid to all removed parts.

Install the spring together with the 1st rubber cup.

- * During assembly, the main piston and spring must be installed as a unit without exchange.
- * When assembling the piston, soak the cups in brake fluid for a while.
- * Install the cups with the cup lips facing the correct direction.

Install the main piston, spring and snap ring.
Install the rubber cover.
Install the brake lever.

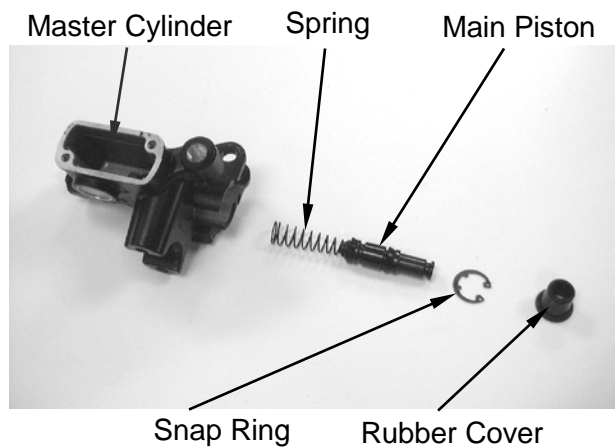

14. STEERING HANDLEBAR/FRONT WHEEL/FRONT BRAKE/FRONT SHOCK ABSORBER/FRONT FORK

Place the brake master cylinder on the handlebar and install the holder with the “up” mark facing up. Also align the punch mark with the holder joint seam.

First tighten the upper bolt and then tighten the lower bolt.

Torque: 12 N-m

Install the brake fluid tube with the attaching bolt and two sealing washers, then tighten the fluid tube bolt.

Connect the front stop switch wire connector.
Install the handlebar covers. (⇒2-3)



Bolts

BRAKE FLUID REFILLING

Keep the handlebar upright and remove the brake reservoir cover and diaphragm.

Add DOT-4 brake fluid to the brake reservoir.

- * When bleeding, be careful not to allow air in the brake reservoir flowing into the brake system.
- * When using a brake bleeder, follow the manufacturer's instructions.
- * Never use dirty or unspecified brake fluid or mix different brake fluids because it will damage the brake

Stop Switch Wire Connector



Washer

BRAKE FLUID BLEEDING

Keep the handlebar upright and remove the brake reservoir cover and diaphragm. Add the specified brake fluid to the upper limit.

- * Do not allow dust or water to enter the brake system during refilling.
- * When servicing the brake system, use towels to cover plastic parts and coated surfaces to avoid damage caused by splash of brake fluid.

In order to avoid spilling brake fluid, connect a transparent hose to the bleed valve.

Warning

Brake fluid spilled on brake pads or brake disk will reduce the braking effect. Clean the brake pads and brake disk with a high quality brake degreaser.

Fully apply the brake lever and then loosen the brake caliper bleed valve to drain the brake fluid until there is no air bubbles in the brake fluid. Then, tighten the bleed valve.

Repeat these steps until the brake system is free of air.

Bleed Valve



BRAKE CALIPER

REMOVAL

First drain the brake fluid from the hydraulic brake system.

Remove the brake fluid tube bolt.

Remove the two bolts attaching the brake caliper.

Remove the brake caliper.



INSTALLATION

Install the two brake pads.

Install the two brake pad dowel pin and tighten them.

* When installing the brake caliper, be sure to position the brake disk between the two brake pads.

Install the brake caliper to the shock absorber and tighten the two bolts.

Torque: 35 N-m

Connect the brake fluid tube with the attaching bolt and two sealing washers to the brake caliper and tighten the fluid tube bolt.

Torque: 35 N-m

Fill the brake reservoir with the specified brake fluid and bleed air from the brake system. (⇒14-10)

* When installing the brake fluid tube, be sure to install the two sealing washers.

Washers Brake Fluid Tube

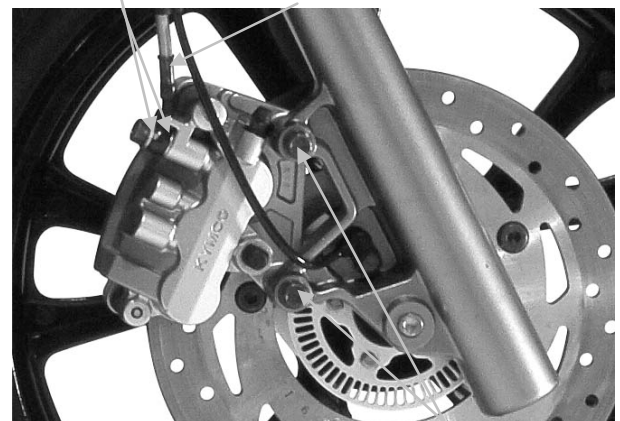

Bolts

FRONT SHOCK ABSORBER

REMOVAL

Remove the front cover. (⇒2-5)
Remove the front wheel. (⇒15-5)
Remove the front brake caliper. (⇒15-11)
Remove the front shock absorber upper mount bolts.
Loosen the lower mount bolts to remove the front shock absorbers.

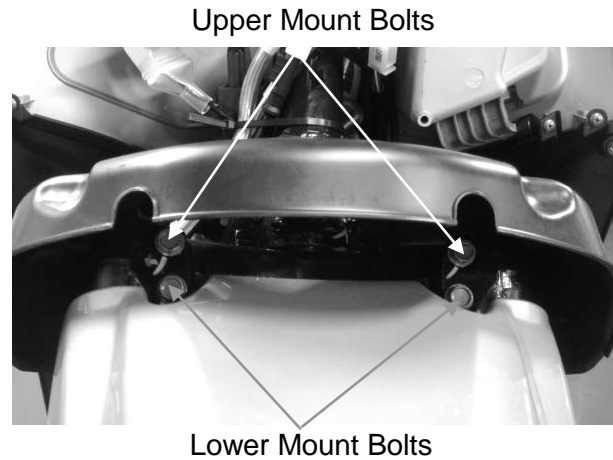

INSTALLATION

Install the front shock absorbers onto the front fork.
Install and tighten the front shock absorber upper mount bolts.
Tighten the lower mount bolts.

Torque: 27 N-m

* Align the hole of upper mount bolt with the groove on the front fork.

Install the front wheel. (⇒15-7)

Standard oil capacity: 177±1cc

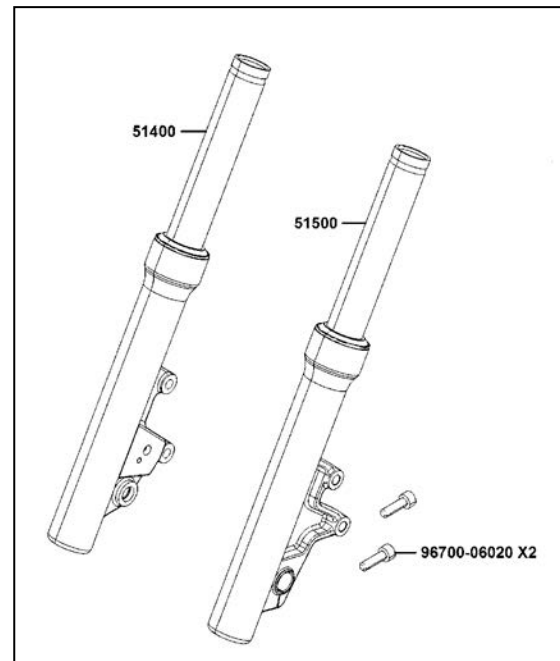

Front Shock Absorber

14. STEERING HANDLEBAR/FRONT WHEEL/FRONT BRAKE/FRONT SHOCK ABSORBER/FRONT FORK



People S 300 ABS

FRONT FORK

REMOVAL

Remove the handlebar covers. (⇒2-3)
Remove the steering handlebar. (⇒15-4)
Remove the front cover. (⇒2-5)
Remove the front fender cover. (⇒2-6)
Remove the front wheel. (⇒15-5)
Remove the front brake caliper. (⇒15-11)
Remove the front shock absorbers.
Hold the steering stem top cone race and remove the steering stem lock nut.
Remove the top cone race and remove the front fork.

* Be careful not to lose the steel balls (26 on top race and 19 on bottom race).

Inspect the ball races, cone races and steel balls for wear or damage. Replace if necessary.

BOTTOM CONE RACE REPLACEMENT

Remove the bottom cone race using a chisel.

Drive a new bottom cone race into place with a proper driver.

* Be careful not to damage the steering stem and front fork.

BALL RACE REPLACEMENT

Drive out the ball races.
Drive in new ball races.

* Be sure to drive the ball races into place completely.

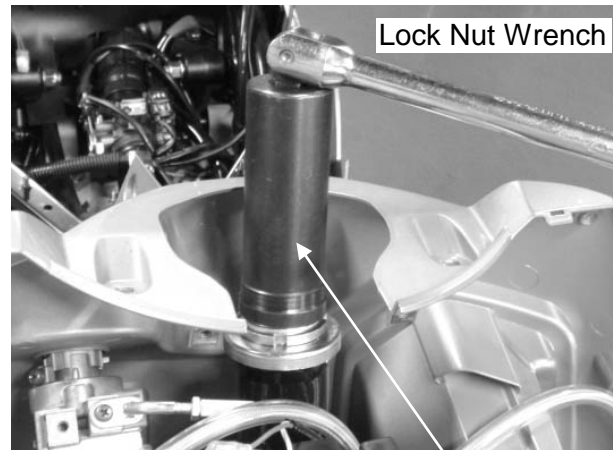

Lock Nut Wrench

Lock Nut Socket

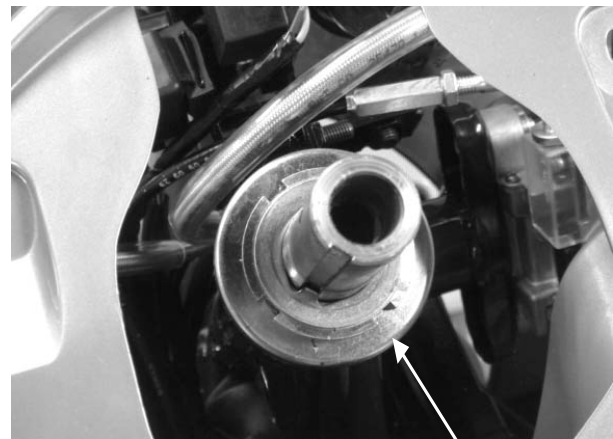

Top Cone Race

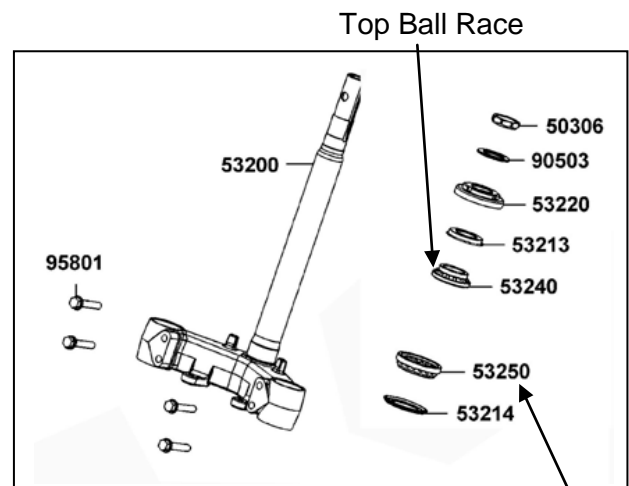

Bottom Ball Race

14. STEERING HANDLEBAR/FRONT WHEEL/FRONT BRAKE/FRONT SHOCK ABSORBER/FRONT FORK

INSTALLATION

Apply grease to the top and bottom ball races and install 26 steel balls on the top ball race and 19 steel balls on the bottom ball race.

Install the front fork.

Apply grease to the top cone race and install it.

Tighten the top cone race and then turn the steering stem right and left several times to make steel balls contact each other closely.

* Make sure the steering stem rotates freely without vertical play.

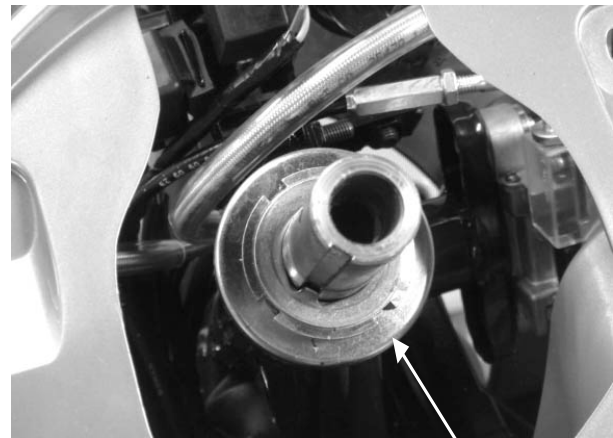

Top Cone Race

Install the steering stem lock nut and tighten it while holding the top cone race.

Torque: 63 N-m

Install the front wheel. (⇒15-7)

Install the front brake caliper. (⇒15-12)

Install the front fender cover. (⇒2-6)

Install the throttle grip and the right and left handlebar switches. (⇒15-5)

Install the right and left brake master cylinders. (⇒15-5)



Lock Nut Socket

15. REAR BRAKE/REAR FORK/REAR WHEEL/REAR SHOCK ABSORBER



People S 300 ABS

REAR BRAKE/REAR FORK/REAR WHEEL/
REAR SHOCK ABSORBER

SCHEMATIC DRAWING	15-1
SERVICE INFORMATION	15-2
TROUBLESHOOTING	15-2
REAR BRAKE	15-3
REAR FORK.....	15-4
REAR WHEEL	15-5
REAR SHOCK ABSORBER	15-5

15. REAR BRAKE/REAR FORK/REAR WHEEL/REAR SHOCK ABSORBER



People S 300 ABS

SCHEMATIC DRAWING

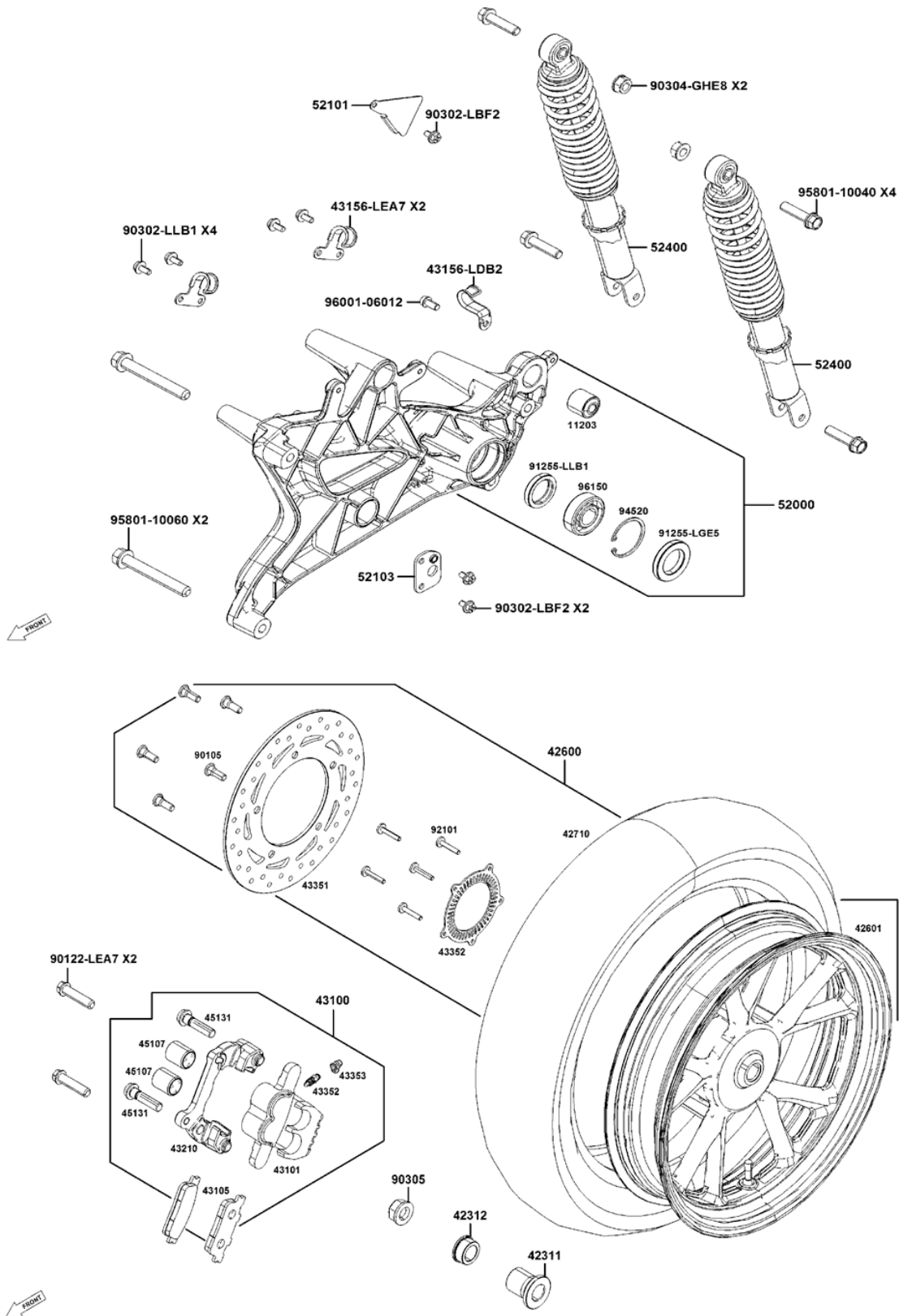

15. REAR BRAKE/REAR FORK/REAR WHEEL/REAR SHOCK ABSORBER



People S 300 ABS

SERVICE INFORMATION

GENERAL INSTRUCTIONS

- When performing the services stated in this section, the engine and exhaust muffler must be cold to avoid scalding.
- During servicing, keep oil or grease off the brake pads and brake disk.

SPECIFICATIONS

Item	Standard (mm)	Service Limit (mm)
Rear wheel rim runout	—	2.0
Rear brake disk thickness	5.0	4.0
Rear brake disk runout	—	0.30
Rear brake master cylinder I.D.	27.00	27.05
Rear brake master cylinder piston O.D.	26.95	26.90

TORQUE VALUES

Exhaust muffler lock bolt	35 N-m
Exhaust muffler pipe nut	20 N-m
Rear axle nut	140 N-m
Rear shock absorber lower mount bolt	40 N-m
Rear shock absorber upper mount bolt	40 N-m
Rear brake caliper holder bolt	35 N-m

TROUBLESHOOTING

Rear wheel wobbling

- Bent rim
- Faulty tire
- Axle not tightened properly

Soft rear shock absorber

- Weak shock absorber spring
- Damper oil leaks

Rear wheel noise

- Worn rear wheel axle bearings
- Worn rear fork bearings
- Deformed rear fork

Poor brake performance

- Air in brake system
- Deteriorated brake fluid
- Contaminated brake pad surface
- Worn brake pads
- Clogged brake fluid line
- Deformed brake disk
- Unequal worn brake caliper

15. REAR BRAKE/REAR FORK/REAR WHEEL/REAR SHOCK ABSORBER

REAR BRAKE

REAR BRAKE CALIPER REMOVAL

First remove the exhaust muffler. (⇒2-10)
Remove the rear brake fluid tube bolt and disconnect the brake fluid tube.
Remove two bolts attaching the rear brake caliper.
Remove the rear brake caliper.

* When removing the brake fluid tube, use shop towels to cover plastic parts and coated surfaces to avoid damage.

INSPECTION

Inspect the brake pads and brake disk.

Measure the brake disk thickness.

Service Limit: 4.0 mm replace if below

Visually check the brake pad thickness and it should not exceed the wear indicator mark.

DISASSEMBLY

Remove two brake pads dowel pins and three bolts from the brake caliper.
Remove the brake pads.

Fluid Tube Bolt

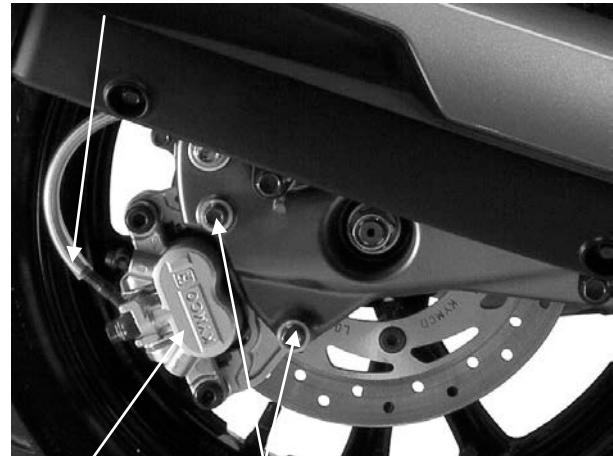

Brake Caliper

Bolts

Brake Disk

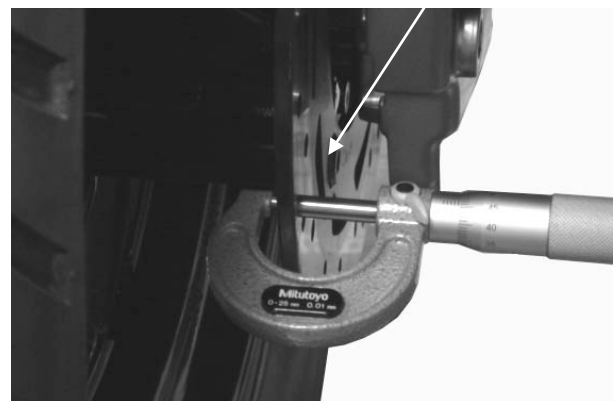

Dowel Pin



Brake Pads

15. REAR BRAKE/REAR FORK/REAR WHEEL/REAR SHOCK ABSORBER

INSTALLATION

Install the brake caliper to the rear fork and tighten the two bolts.

Torque: 35 N-m

Connect the brake fluid tube to the brake caliper and install fluid tube bolt, copper washers and tighten the fluid tube bolt.

Fill the brake reservoir with the specified brake fluid and bleed air from the brake system. (⇒14-10)

* When installing the brake fluid tube, be sure to install the two copper sealing washers.

Fluid Tube Bolt

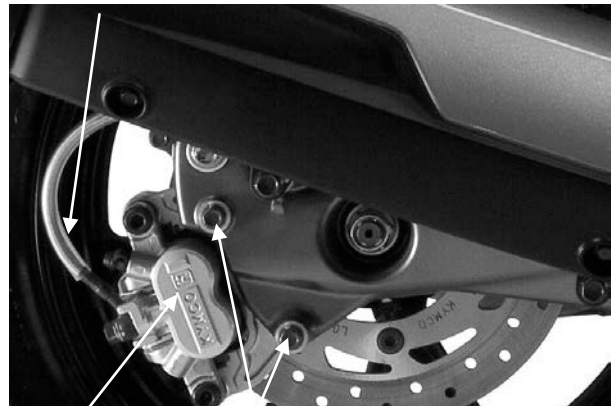

Brake Caliper Bolts

REAR FORK

REMOVAL

Remove the exhaust muffler. (⇒2-10)

Remove the rear brake caliper. (⇒16-3)

Remove the right rear shock absorber lower mount bolt.

Remove the rear axle nut and remove the collar.

Remove the rear fork.



Bolt

The installation sequence is the reverse of removal.

Turn the inner race of each bearing with your finger to see if they turn smoothly and quietly.

Also check if the outer race fits tightly in the hub.

Replace the bearings if the races do not turn smoothly, quietly, or if they fit loosely in the hub.

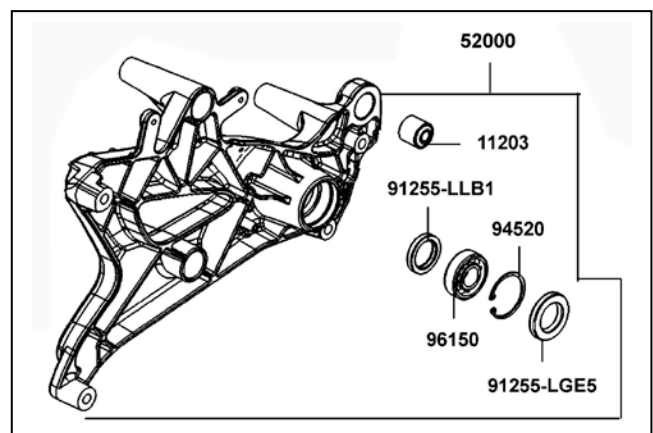

15. REAR BRAKE/REAR FORK/REAR WHEEL/REAR SHOCK ABSORBER

REAR WHEEL REMOVAL

- Remove the exhaust muffler. (⇒2-10)
- Remove the rear brake caliper. (⇒16-3)
- Remove the rear fork. (⇒16-6)
- Remove the rear axle collar.
- Remove the rear wheel.

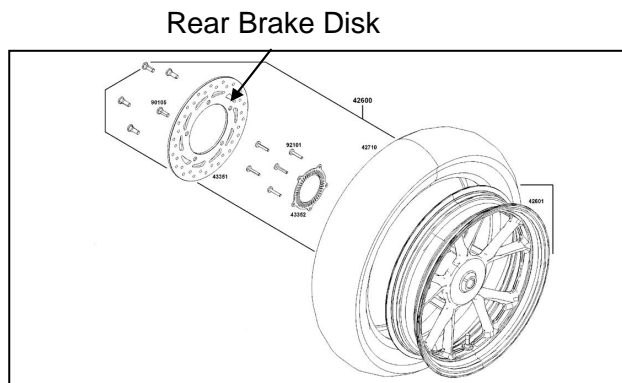

INSPECTION

Measure the rear wheel rim runout.

Service Limits:

- Radial:** 2.0mm replace if over
- Axial:** 2.0mm replace if over

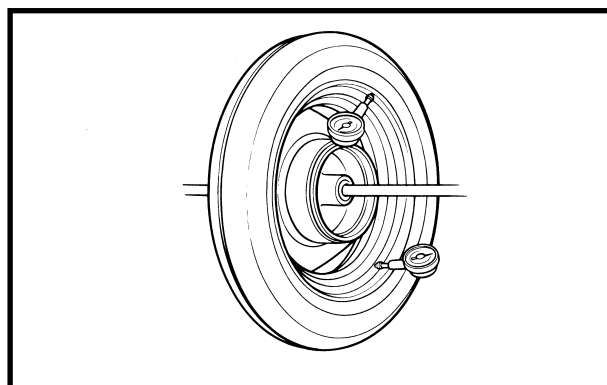

INSTALLATION

The installation sequence is the reverse of removal.

Torque:

- Rear shock absorber lower mount bolt: 40 N-m
- Rear axle nut: 140 N-m



Bolt

REAR SHOCK ABSORBER REMOVAL

- Remove the met-in box and carrier. (⇒2-6)
- Remove the body cover, center cover and rear fender A together. (⇒2-6)
- Remove the right/left rear shock absorber upper and lower mount bolts.
- Remove the right and left rear shock absorbers.

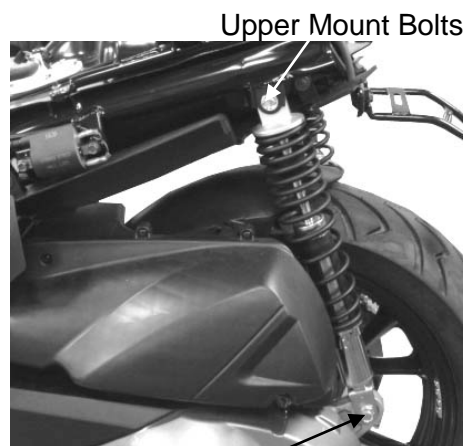

15. REAR BRAKE/REAR FORK/REAR WHEEL/REAR SHOCK ABSORBER

INSTALLATION

Install the rear shock absorbers in the reverse order of removal.

Torque:

Upper Mount Bolt: 40 N-m

Lower Mount Bolt: 40 N-m

ADJUSTABLE REAR CUSHION

To suit scooter comfortable to load condition rear cushion could be adjusted in spring preload.

It is possible to adjust rear cushion in three positions:

A position "soft"

B position "medium"

C position "hard"

When adjusting rear cushion, the spring preload of rear cushions must be the same.

Standard spring preload position:

People S 300 ABS: 2nd

A cushion adjust wrench is provided with new scooter.

The rear right cushion can be adjusted directly with the wrench tool.

Disconnect the breather hose from air cleaner and keep air cleaner up to adjust rear left cushion with wrench tool.

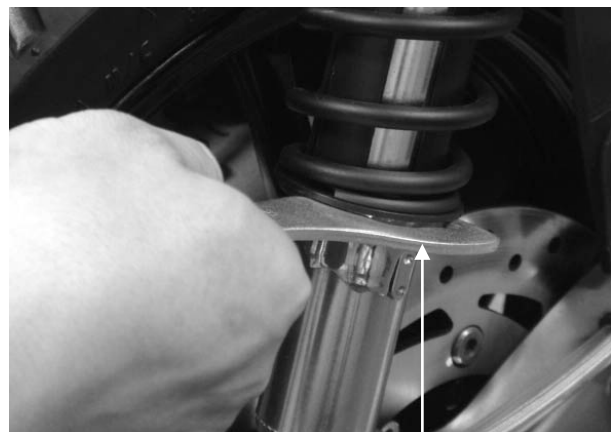
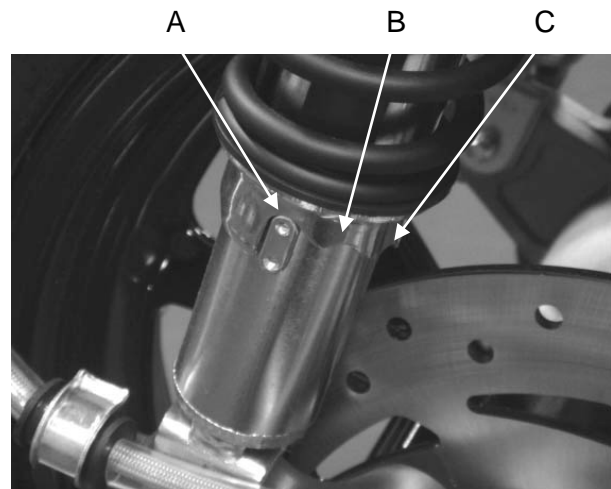

Wrench

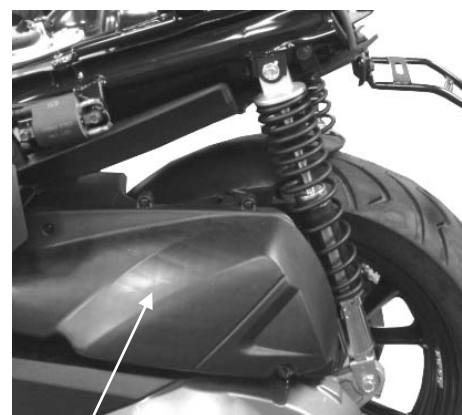

Air Cleaner

16. BATTERY/CHARGING SYSTEM

16

BATTERY/CHARGING SYSTEM

CHARGING SYSTEM LAYOUT -----	16-1
CHARGING CIRCUIT -----	16-1
SERVICE INFORMATION-----	16-2
TROUBLESHOOTING-----	16-3
BATTERY CHARGING -----	16-4
CHARGING SYSTEM -----	16-6
REGULATOR/RECTIFIER -----	16-6

16. BATTERY/CHARGING SYSTEM

CHARGING SYSTEM LAYOUT



Battery

AC Generator

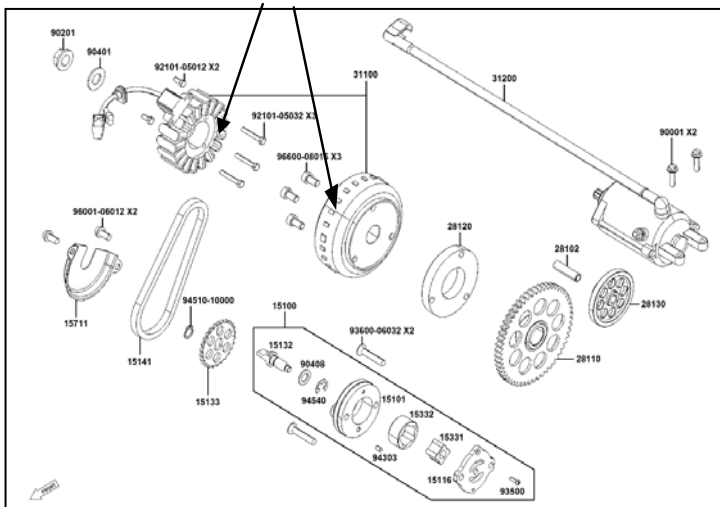

Regulator/Rectifier

16. BATTERY/CHARGING SYSTEM

SERVICE INFORMATION

GENERAL INSTRUCTIONS

- * The battery electrolyte (sulfuric acid) is poisonous and may seriously damage the skin and eyes. Avoid contact with skin, eyes, or clothing. In case of contact, flush with water and get prompt medical attention.
- The batter can be charged and discharged repeatedly. If a discharged battery is not used for a long time, its service life will be shortened. Generally, the capacity of a battery will decrease after it is used for 2~3 years. A capacity-decreased battery will resume its voltage after it is recharged but its voltage decreases suddenly and then increases when a load is added.
 - When a battery is overcharged, some symptoms can be found. If there is a short circuit inside the battery, no voltage is produced on the battery terminals. If the rectifier won't operate, the voltage will become too high and shorten the battery service life.
 - If a battery is not used for a long time, it will discharge by itself and should be recharged every 3 months.
 - A new battery filled with electrolyte will generate voltage within a certain time and it should be recharged when the capacity is insufficient. Recharging a new battery will prolong its service life.
 - Inspect the charging system according to the sequence specified in the Troubleshooting.
 - Do not disconnect and soon reconnect the power of any electrical equipment because the electronic parts in the regulator/rectifier will be damaged. Turn off the ignition switch before operation.
 - It is not necessary to check the MF battery electrolyte or fill with distilled water.
 - Check the load of the whole charging system.
 - Do not quick charge the battery. Quick charging should only be done in an emergency.
 - Remove the battery from the motorcycle for charging.
 - When replacing the battery, do not use a traditional battery.
 - When charging, check the voltage with an electric tester.

SPECIFICATIONS

		Item	Standard
Battery	Capacity		12V10AH
	Voltage (20°C)	Fully charged	13.2V
		Insufficient charged	< 12.3V
	Charging current		1.2A* 5~10H

16. BATTERY/CHARGING SYSTEM

TROUBLESHOOTING

No power

- Dead battery
- Disconnected battery cable
- Fuse burned out
- Faulty ignition switch

Low power

- Weak battery
- Loose battery connection
- Charging system failure
- Faulty regulator/rectifier

Intermittent power

- Loose battery cable connection
- Loose charging system connection
- Loose connection or short circuit in ignition system

Charging system failure

- Loose, broken or shorted wire or connector
- Faulty regulator/rectifier
- Faulty A.C. generator

16. BATTERY/CHARGING SYSTEM

BATTERY REMOVAL

The battery is under the floorboard.
Remove the two screws attaching the battery cover.
Pull battery out to expose the terminal leads.
Disconnect the negative (-) terminal lead from the battery first, then disconnect the positive (+) terminal lead.
Remove the battery from the battery box.

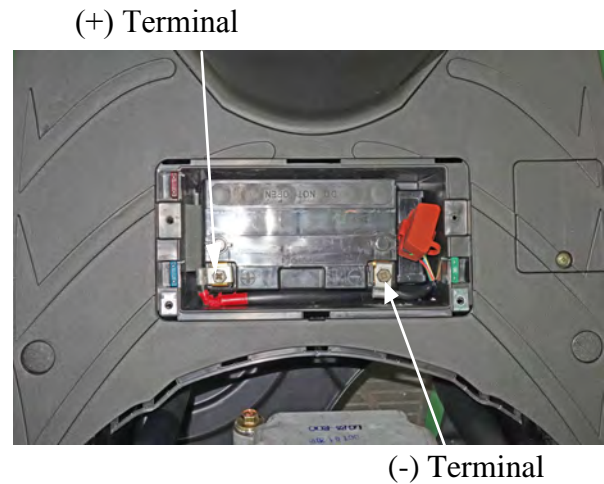

BATTERY INSTALLATION

Install in the reverse order of the removal.

* When install the battery, first connect the positive (+) cable and then negative (-) cable to avoid short circuit.

VOLTAGE INSPECTION

Remove the battery cover.
Measure the battery voltage by using a commercially available digital multimeter.

Voltage (20°C/68°F):

Fully charged: 13.0 ~ 13.2 V

Insufficient charged: < 12.3 V

16. BATTERY/CHARGING SYSTEM

BATTERY CHARGING

Remove the battery

Connect the charger positive (+) cable to the battery positive (+) terminal.

Connect the charger negative (-) cable to the battery negative (-) terminal.

* Turn the power ON/OFF at the charger, not at the battery terminals.

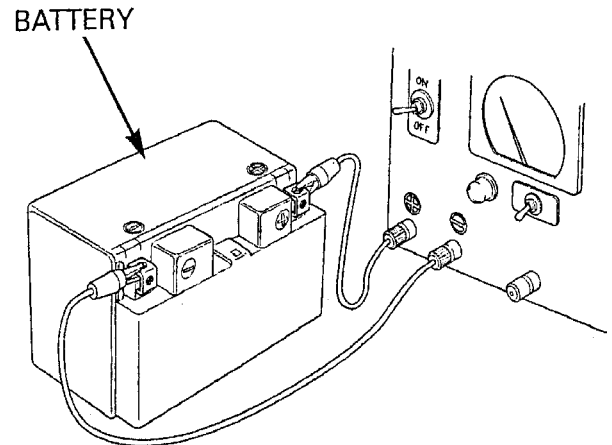

CHARGING CURRENT:

Standard: 1.2A / 5~10 Hours

For battery charging, do not exceed the charging current and time specified on the battery. Using excessive current or extending the charging time may damage the battery.

CHARGING VOLTAGE INSPECTION

Be sure that the battery is in good condition before performing this test.

* Do not disconnect the battery or any cable in the charging system without first switching off the ignition switch. Failure to follow this precaution can damage the tester or electrical

Start the engine and warm it up to the operating temperature; stop the engine.

Connect the multimeter between the positive (+) and negative (-) terminals of the battery.

To prevent short, make absolutely certain which are the positive (+) and negative (-) terminals or cable.

With the headlight on and turned to the high beam position, restart the engine.

Measure the voltage on the multimeter when the engine runs at 5000 rpm.

Standard:

Battery charging voltage 14 ~ 15V

16. BATTERY/CHARGING SYSTEM

REGULATOR/RECTIFIER

WIRE HARNESS INSPECTION

Remove the luggage box
Disconnect the regulator/rectifier connectors.
Check the connectors for loose contacts of corroded terminals.

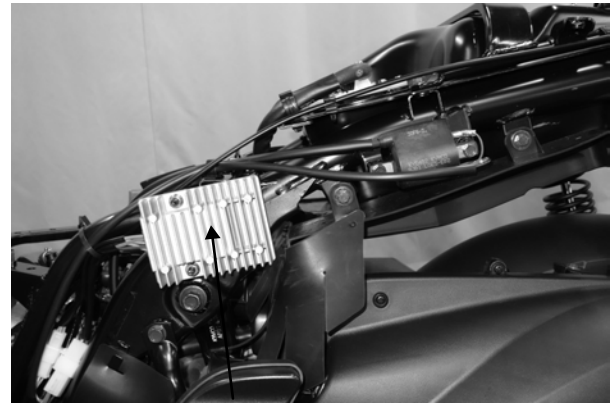

Regulator/Rectifier

BATTERY WIRE

Measure the voltage between the Red/White wire terminal and ground.
There should be battery voltage at all times.



GROUND WIRE

Check the continuity between the Green wire terminal and ground.
There should be continuity at all times.



16. BATTERY/CHARGING SYSTEM

CHARGING COIL WIRE

Measure the resistance between each Yellow wire terminals.

Standard: 0.4 ~ 0.6 Ω (20°C/68°F)

Disconnect the regulator/rectifier connector.
Check for continuity between each Yellow wire terminal regulator/rectifier side and ground.

There should be no continuity.



REMOVAL/INSTALLATION

Remove the side body cover.

Disconnect the regulator/rectifier connectors.

Remove the two bolts, regulator/rectifier.

Installation is in the reverse order of removal.

Regulator/Rectifier

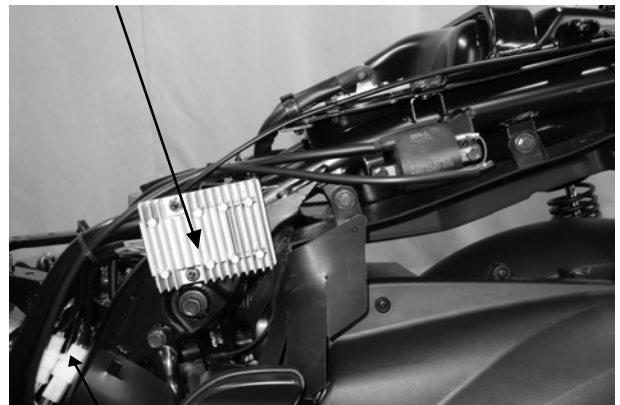

Connectors

17. IGNITION SYSTEM

IGNITION SYSTEM

IGNITION SYSTEM LAYOUT	17-1
SERVICE INFORMATION	17-2
TROUBLESHOOTING	17-2
SPARK PLUG	17-3
IGNITION COIL INSPECTION	17-3
A.C. GENERATOR INSPECTION	17-4
TILT SWITCH INSPECTION	17-4

17. IGNITION SYSTEM

IGNITION SYSTEM LAYOUT

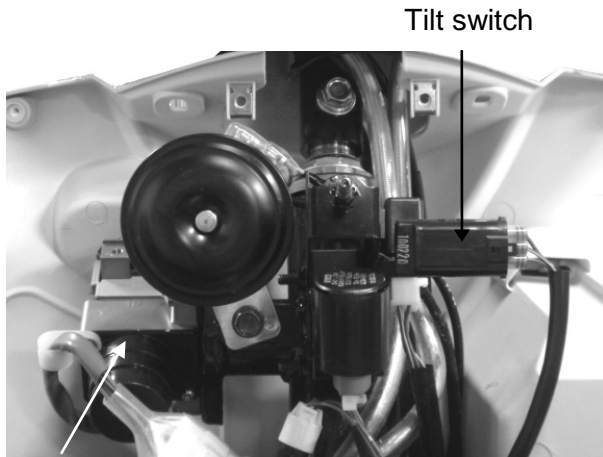

Tilt switch

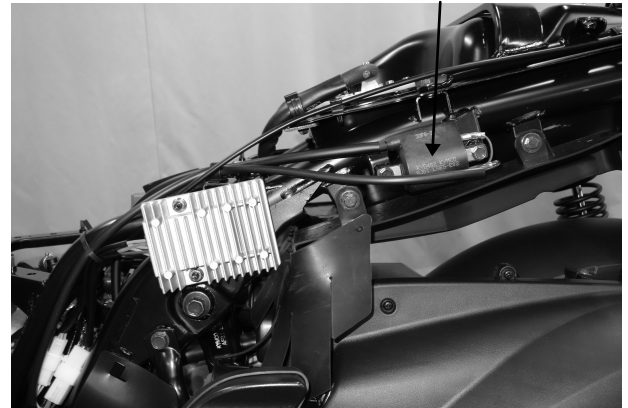

Ignition Coil

Ignition Switch

IGNITION CIRCUIT

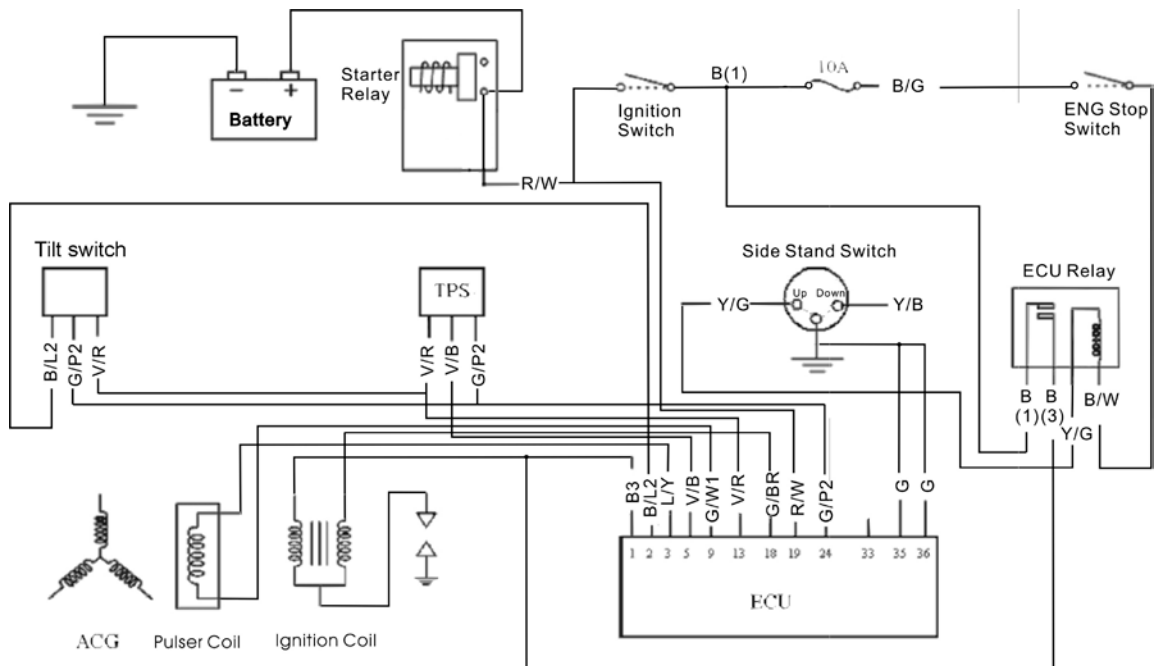

17. IGNITION SYSTEM

SERVICE INFORMATION

GENERAL INSTRUCTIONS

- Some electrical components may be damaged if terminals or connectors are connected or disconnected while the ignition switch is "ON" and current is present.
- When servicing the ignition system, always follow the steps in the troubleshooting on page 17-2.
- The ignition timing cannot be adjusted since the ignition control module is already adjusted in factory.
- The ignition control module or ECU maybe damaged if dropped or the connector is disconnected when the key is " ON ", the excessive voltage may damage the ignition control module or ECU. Always turn off the ignition switch before servicing.
- A faulty ignition system is often related to poor connections. Check those connections before proceeding.
- Make sure the battery is adequately charged. Using the starter motor with weak battery results in a slower engine cranking speed as well as no spark at the spark plug.
- Use a spark plug of the correct heat range. Using spark plug with an incorrect heat range can damage the engine.

SPECIFICATIONS

Item		Standard
Spark plug	Standard type	NGK CR7E
Spark plug gap		0.7 ~ 0.8 mm
Inductive Ignition Coil	Primary coil	3.57~4.83Ω
	Secondary coil without plug cap	10.42~14.49 KΩ
Throttle Position Sensor		3500~6500Ω
Fuel Pump		1.9 Ω about
Fuel Injector		11.7±0.6Ω
Water Temperature Sensor		2.076KΩ±10% (25°C)
Oxygen Sensor (engine warming condition)		6.7Ω~9.5Ω
Crank Position Sensor		115Ω±15Ω
Tilt Switch		0.4V~1.4V(normal) 3.7V~4.4V (fall down)

TROUBLESHOOTING

No peak voltage

- Short circuit in engine stop switch or ignition switch wire.
- Faulty engine stop switch or ignition switch.
- Loose or poorly connected ignition control module connectors.
- Open circuit or poor connection in ground wire of the ignition control module.
- Faulty crank position sensor.
- Faulty ignition control module.

Peak voltage is normal, but no spark jumps at the plug

- Faulty spark plug or leaking ignition coil secondary current.
- Faulty ignition coil.

17. IGNITION SYSTEM

SPARK PLUG

For spark plug inspection and adjustment, refer to page 3-5.

IGNITION COIL INSPECTION

Remove the seat and met-in box. (⇒2-6)
Remove the ignition coil.

Ignition Coil

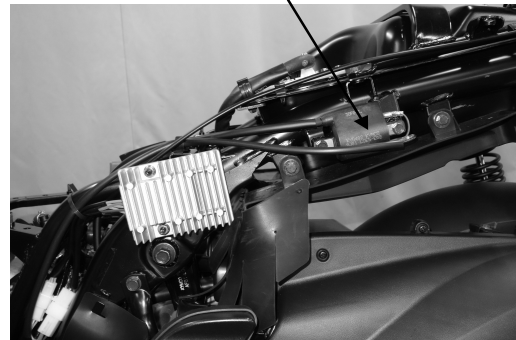

IGNITION COIL CONTINUITY TEST

Inspect the continuity of the ignition coil, primary coil and secondary coil.

* This is a general test. Accurate ignition coil test must be performed with an ignition unit tester.

Primary Coil

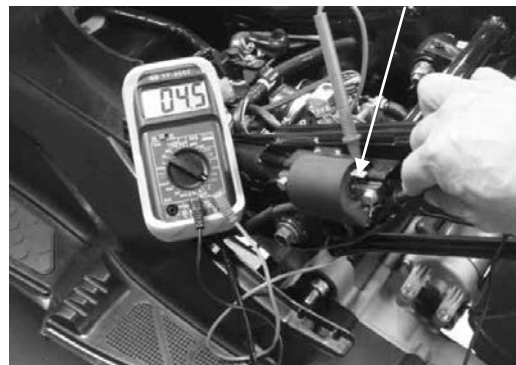

Secondary Coil with plug cap



Measure the ignition coil resistances at 20°C.

Primary coil	3.57~4.83Ω
Secondary coil with plug cap	15 ~ 19 KΩ
Secondary coil without plug cap	10 ~14 KΩ

Secondary Coil without plug cap



17. IGNITION SYSTEM

A .C. GENERATOR INSPECTION

CRANK POSITION SENSOR INSPECTION

* This test is performed with the stator installed in the engine.

Remove the seat and met-in box.
 Disconnect the Crank Position Sensor Wire Coupler.
 Measure the resistance between the blue/white and green/white wire terminals.

Blue/Yellow ~ Green/White	115Ω±15Ω
---------------------------	----------

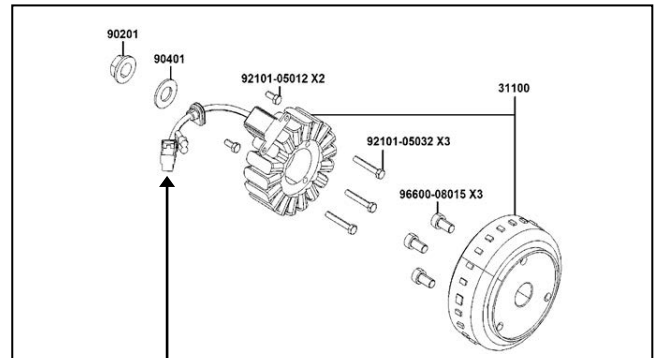

Crank Position Sensor Wire Coupler

TILT SWITCH

INSPECTION

Support the scooter level surface.
 Put the side stand up and engine stop switch is at "RUN".
 Turn the ignition switch to "OFF".
 Remove the screws, washers and tilt switch.

* Do not disconnect the tilt switch connector during inspection.
 The capacity of battery must be fully charged.

Place the tilt switch vertical as shown at the ignition switch "ON". Measure the voltage as below.

Terminal	Standard
Violet/Red (+) – Green/Pink (-)	5 V (ECU voltage)
Black/Blue (+) – Green/Pink (-)	0.4 ~ 1.4 V less

Incline the tilt switch 65±10 degrees to the left or right at the ignition switch "ON". Measure the voltage as below.

Terminal	Standard
Violet/Red (+) – Green/Pink (-)	5 V (ECU voltage)
Black/Blue (+) – Green/Pink (-)	3.7 ~ 4.4 V

If repeat this test, first turn the ignition switch to "OFF", then turn the ignition switch to "ON".

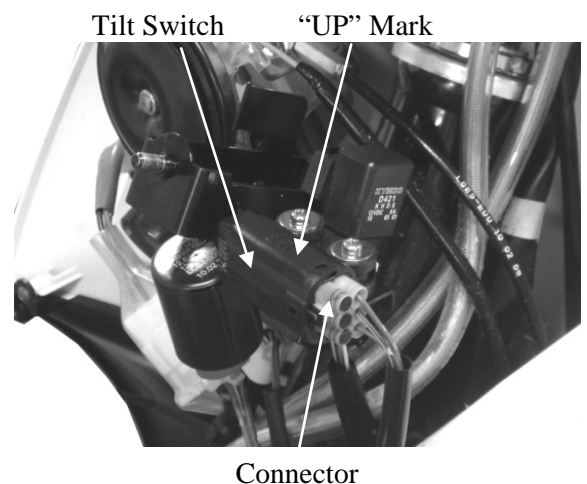

17. IGNITION SYSTEM

REMOVAL/INSTALLATION

Disconnect the connector and remove two screws, then remove tilt switch.

Installation is in the reverse order of removal.

*

Install the tilt switch with its “up” mark facing up.

Tighten the mounting screws securely.

18. STARTING SYSTEM

18

STARTING SYSTEM

STARTING SYSTEM LAYOUT	18-1
SERVICE INFORMATION	18-2
TROUBLESHOOTING	18-2
STARTER MOTOR	18-3
STARTER RELAY INSPECTION.....	18-4

18. STARTING SYSTEM

STARTING SYSTEM LAYOUT



Ignition Switch

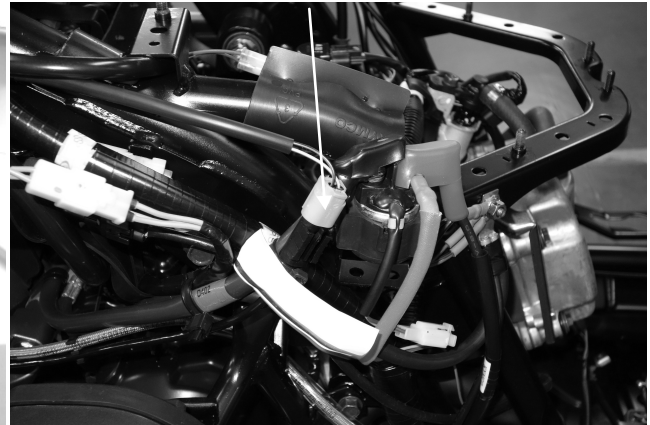

Starter Relay

STARTING CIRCUIT

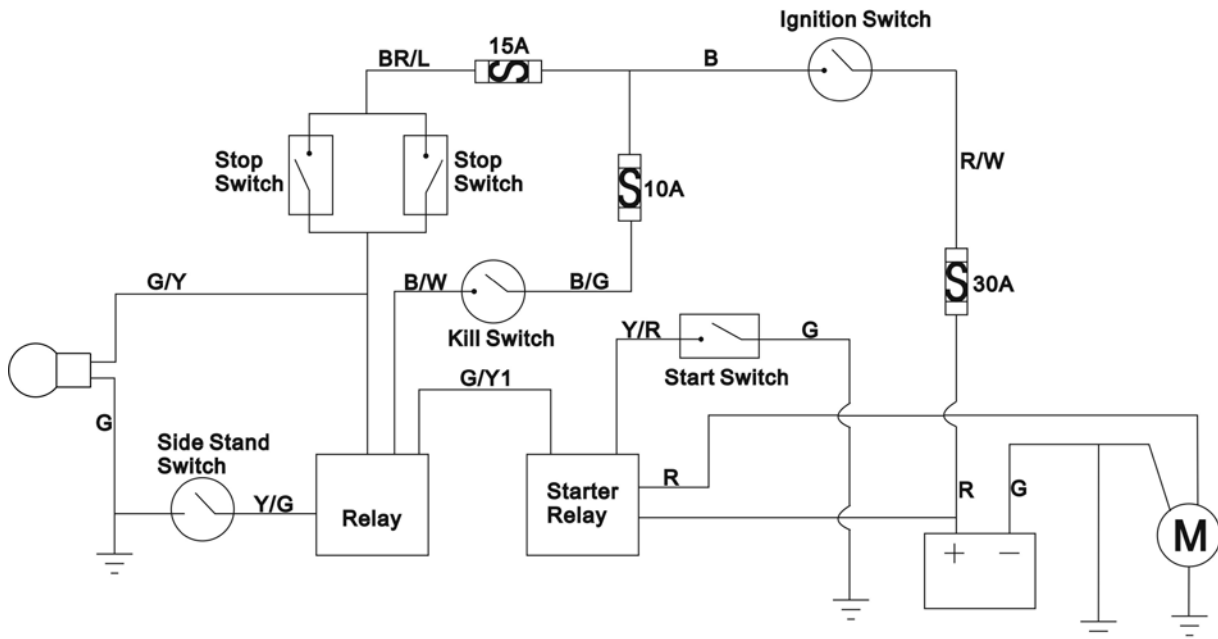

18. STARTING SYSTEM

SERVICE INFORMATION

GENERAL INSTRUCTIONS

- The removal of starter motor can be accomplished with the engine installed.
- After the starter clutch is installed, be sure to add the engine oil and coolant and then bleed air from the cooling system.

SPECIFICATIONS

Item	Standard (mm)	Service Limit (mm)
Starter motor brush length	12.5mm	8.5mm

TORQUE VALUES

Starter motor mounting bolt	6.7~10.8	N-m
Starter motor case screw	2.9~4.9	N-m
Starter clutch bolt	9.8~13.7	N-m

SPECIAL TOOLS

Flywheel holder	E021
Flywheel puller	E003

TROUBLESHOOTING

Starter motor won't turn

- Fuse burned out
- Weak battery
- Faulty ignition switch
- Faulty starter clutch
- Faulty front or rear stop switch
- Faulty starter relay
- Poorly connected, broken or shorted wire
- Faulty starter motor

Lack of power

- Weak battery
- Loosed wire or connection
- Foreign matter stuck in starter motor or gear

Starter motor rotates but engine does not start

- Faulty starter pinion
- Starter motor rotates reversely
- Weak battery

18. STARTING SYSTEM

STARTER MOTOR

REMOVAL

- * Before removing the starter motor, turn the ignition switch OFF and remove the battery ground. Then, turn on the ignition switch and push the starter button to make sure the starter motor can't operate securely.

Remove the seat, met-in box and carrier.
Remove the body cover, center cover and rear fender together.
Remove the nut goes to the starter relay and relax cable band to disconnect the starter motor cable.

Remove two start motor mounting bolts and the motor.

Nut



Starter Motor Cable

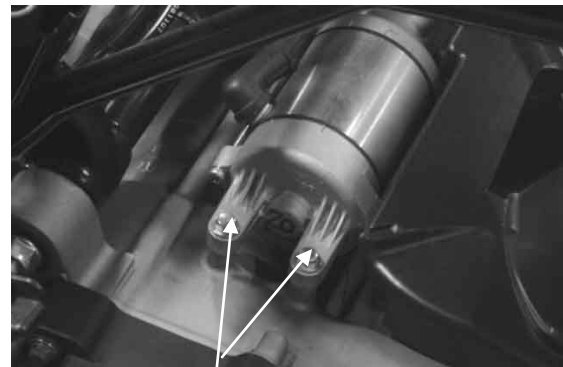

Bolts

18. STARTING SYSTEM

INSTALLATION

Connect the starter motor cable.

Check the O-ring for wear or damage and replace if necessary.

Apply grease to the O-ring and install it to the starter motor.

Tighten the two mounting bolts.

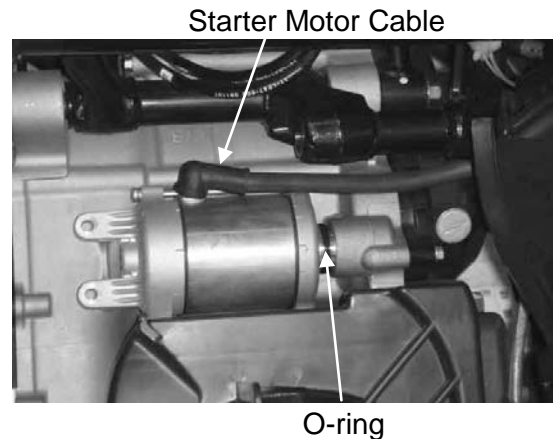

STARTER RELAY INSPECTION

Disconnect the starter relay wire connector.

Check for continuity between the yellow/red wire and green/yellow wire.

There should be continuity when the starter button is depressed.

If there is no continuity, check the starter button for continuity and inspect the wire.



OPERATION TEST

Connect the electric meter to the starter relay terminals that connect to the battery positive cable and the starter motor cable.

Connect a fully charged battery across the starter relay yellow/red and green/yellow wire terminals.

Check for continuity between the starter relay large terminals. The relay is normal if there is continuity and hear sounds.

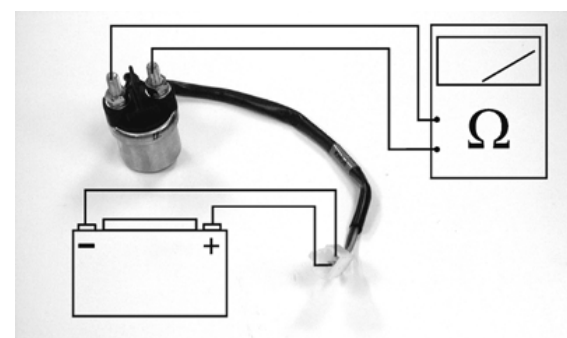

LIGHTS/METERS/SWITCHES

SERVICE INFORMATION-----	19- 1
BULB REPLACEMENT -----	19- 3
BRAKE LIGHT SWITCH-----	19- 5
IGNITION SWITCH -----	19- 5
RIGHT HANDLEBAR SWITCH -----	19- 6
LEFT HANDLEBAR SWITCH -----	19- 7
AUXILIARY OUTLET -----	19- 7
FUEL PUMP -----	19- 8
SIDE STAND SWITCH -----	19-10

ELECTRICAL EQUIPMENT LAYOUT

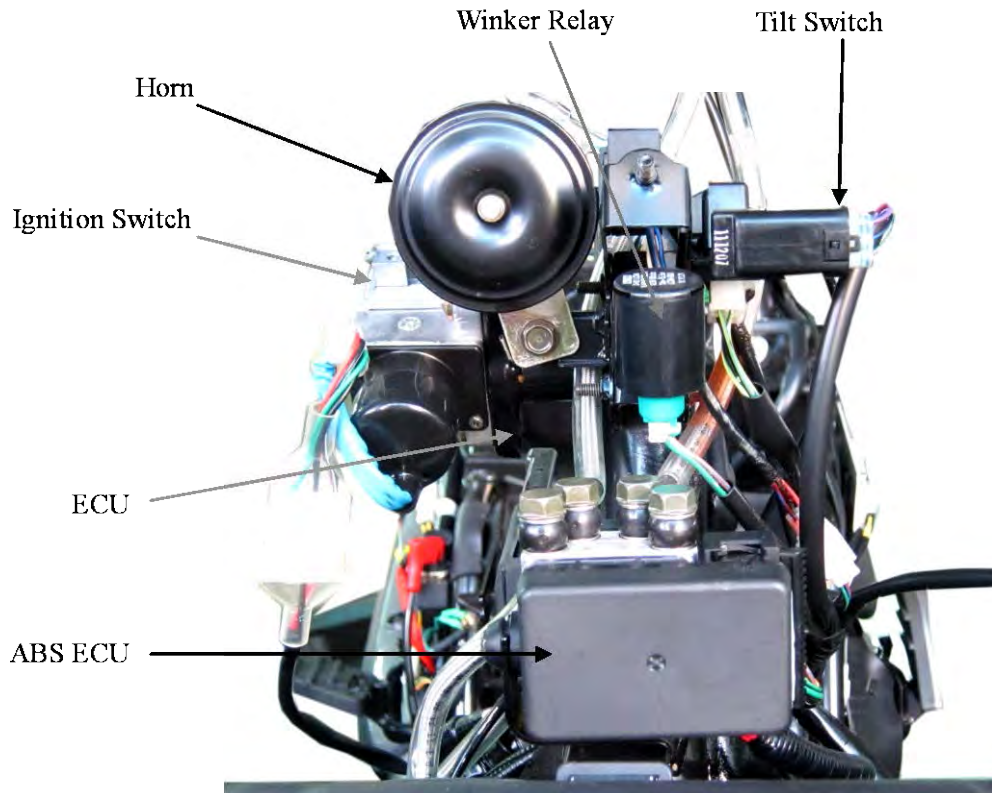
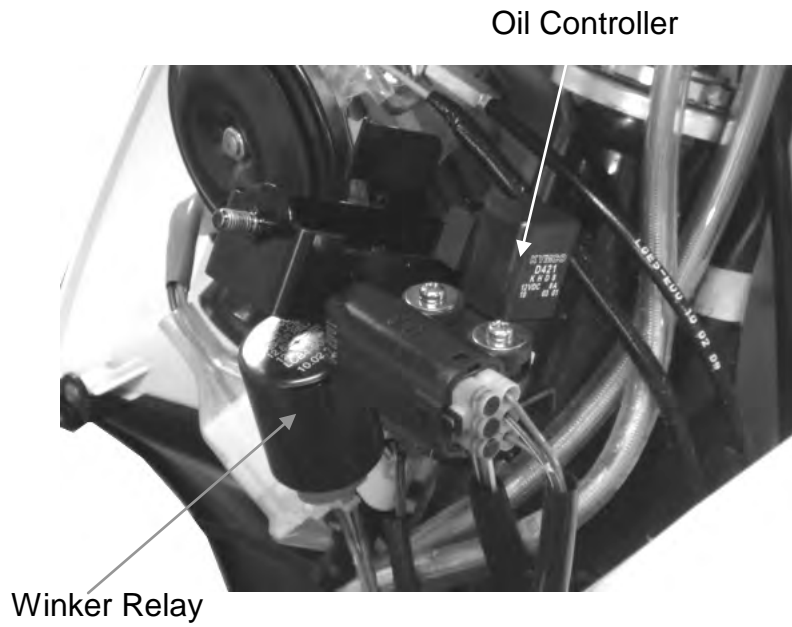

19. LIGHTS SWITCHES/ FUEL PUMP

SERVICE INFORMATION

GENERAL

* A halogen head light bulb becomes very hot while the head light is on, and remains for a while after it is turned off. Be sure to let it cool down before servicing.

- Note the following when replacing the halogen headlight bulb
 - Wear clean gloves while replacing the bulb. Do not put finger prints on the headlight bulb, as they may create hot spots on the bulb and cause it to fail.
 - If you touch the bulb with your bare hands, clean it with a cloth moistened with alcohol to prevent its early failure.
 - Be sure to install the dust cover after replacing the bulb.
- Check the battery condition before performing any inspection that requires proper battery voltage.
- A continuity test can be made with the switches installed on the scooter.
- Route the wires and cables properly after servicing each component.

TROUBLESHOOTING

Lights do not come on when ignition switch is “ON”

- Burned bulb
- Faulty switch
- Poorly connected, broken or shorted wire

Temperature gauge does not register correctly

- Faulty temperature gauge
- Faulty thermosensor
- Broken or shorted wire between the temperature gauge and thermosensor

Fuel gauge does not work or wrong show figures

- Faulty fuel gauge
- Faulty fuel unit
- Poorly connected wire between fuel gauge and fuel unit
- Fuse burned out

SPECIFICATIONS

Fuse	10A/15A/25A/30A
Headlight bulb	12V 12W / 6W (LED)
Turn signal light bulb	12V 2W (LED)
Position light bulb	12V 1.35W (LED)
Stop light / tail light bulb	12V 5.7W / 3.8W (LED)
License light bulb	12V 5W

BULB REPLACEMENT

LICENSE LIGHT

Disconnect the license light bulb socket.
Remove the bulb and replace with a new one.



License light Bulb

HEADLIGHT

* A halogen headlight bulb becomes hot while the headlight is ON and remains for a while after it is turned OFF. Be sure to let it cool down before servicing.

REMOVAL

Remove the handle cover
Disconnect the headlight connector from the headlight bulb.

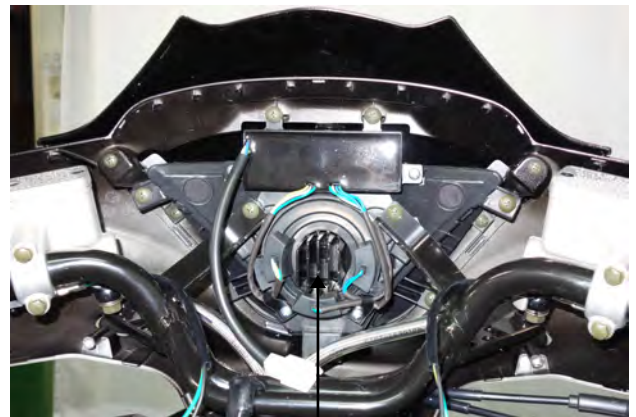

Headlight Bulb

INSTALLATION

Install a new bulb into the headlight case.
Install the headlight and connect the headlight connector

19. LIGHTS/METERS/SWITCHES

FRONT TURN SIGNAL LIGHT

Remove the front cover.
Turn the bulb socket and then remove the front turn signal light.
Push and turn the bulb counterclockwise to remove it, then replace with a new one.
Installation is in the reverse order of removal.



Socket

TAILLIGHT/BRAKE LIGHT/REAR TURN SIGNAL LIGHT

Remove the seat and met-in.
Remove the body covers.
Remove the taillight bulb socket.



Taillight Bulb

REAR TURN SIGNAL LIGHT

Turn the bulb counterclockwise to remove it, then replace with a new one.

Installation is in the reverse order of removal.

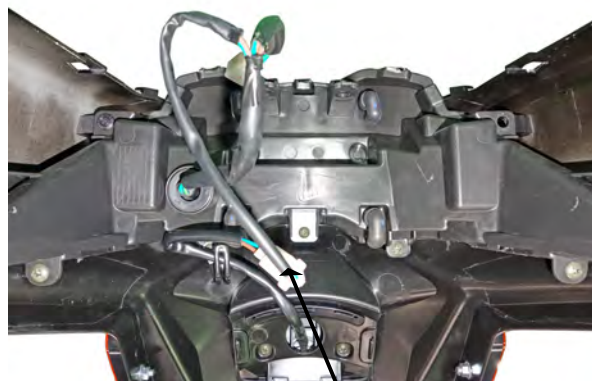

Rear Turn Signal Light

19. LIGHTS/METERS/SWITCHES

BRAKE LIGHT SWITCH

Remove the handlebar cover.

Disconnect front or rear brake light switch connectors and check for continuity between the switch terminals.

There should be continuity with the front or rear brake lever squeezed, and there should be no continuity with the front or rear brake lever is released.



Brake Light Switch

IGNITION SWITCH

INSPECTION

Remove the front cover.

Disconnect the ignition switch connector and check the ignition switch for continuity at the switch side connector terminals.

Continuity should exist between the color code wires as follows:

COMB SW

	BAT2	IG	E	BAT1	HA
LOCK		○—○			
OFF		○—○		○—○	
ON	○—			○—○	
COLOR	B	B/W	G	R	B/L



Ignition Switch

19. LIGHTS/METERS/SWITCHES

RIGHT ENGINE STOP SWITCH

INSPECTION

Remove the handle cover.

Disconnect the right Engine Stop switch connector and check for continuity at switch side connector terminals.

Continuity should exist between the color code wires as follows:



Engine Stop Switch Starter Switch

STARTER SW

	E	ST
FREE		
PUSH	○—○	○—○
COLOR	G	Y/R

ENGINE STOP SW

	IG	BAT3
OFF		
RUN	○—○	○—○
COLOR	B/W	B/G

19. LIGHTS/METERS/SWITCHES

LEFT HANDLEBAR SWITCH

INSPECTION

Disconnect the left handlebar switch connector and check for continuity at switch side connector terminals.

Continuity should exist between the color code wires as follows:

WINKER SW

	WR	R	L
R	○	○	
N			
L	○		○
COLOR	GR	SB	O

HORN SW

	BAT4	HO
FREE		
PUSH	○	○
COLOR	BR/L	LG

DIMMER SW

	HL	HI	LO
LO	○		○
(N)	○	○	○
HI	○	○	
COLOR	W/L	L	W

PASSING SW

	BAT4	HI
FREE		
PUSH	○	○
COLOR	BR/L	L

Dimmer Switch



Horn Switch Turn Signal light Switch

Passing Switch



AUXILIARY OUTLET

INSPECTION

Open the luggage box
Disconnect the auxiliary outlet connector and check for continuity between the switch terminals.

There should be no continuity with the luggage box light switch pushed, and there should be continuity with the luggage box light switch is released.

Auxiliary Outlet



19. LIGHTS/METERS/SWITCHES

FUEL PUMP REMOVAL

Remove the seat and met-in

Remove the center cover

Remove the fuel pump connector

Be sure to relieve the fuel pressure before removing fuel pump or fuel hose.

Remove the six nuts and fuel unit connectors then remove the fuel hose.

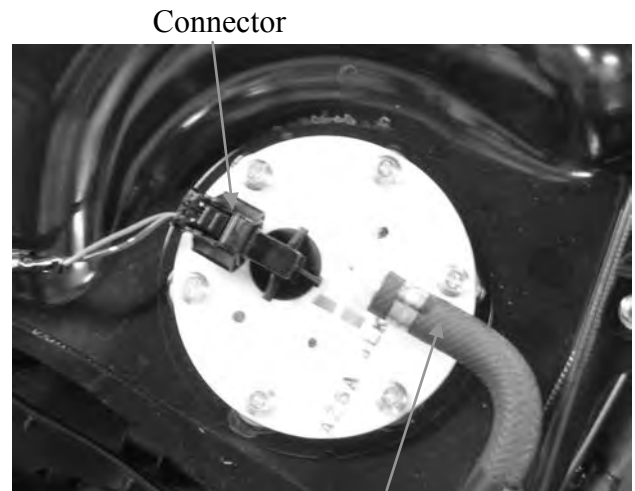

Fuel Hose

Check the fuel pump O-ring.

If was damage, replace a new one.

INSPECTION

Connect the fuel unit wire connectors and turn the ignition switch "ON".

* Before performing the following test, operate the turn signals to determine that the battery circuit is normal.

19. LIGHTS/METERS/SWITCHES

Measure the resistance between the Red/Black and Green wire of the fuel unit connector.

Standard (at 20°C/68°F):

Float at full position	About 1100 Ω
Float at empty position	About 100 Ω

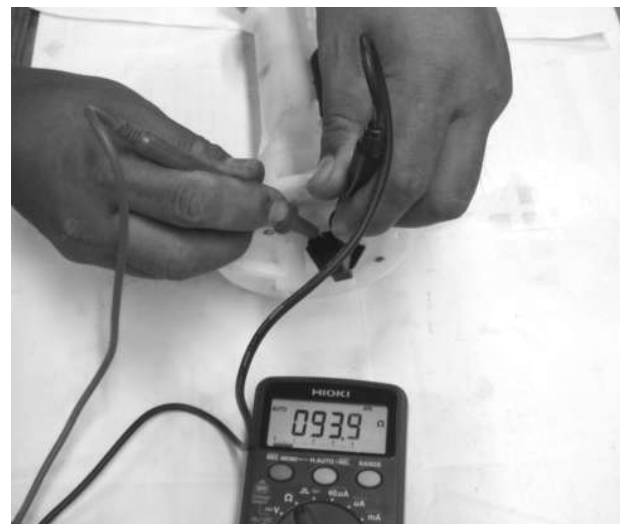
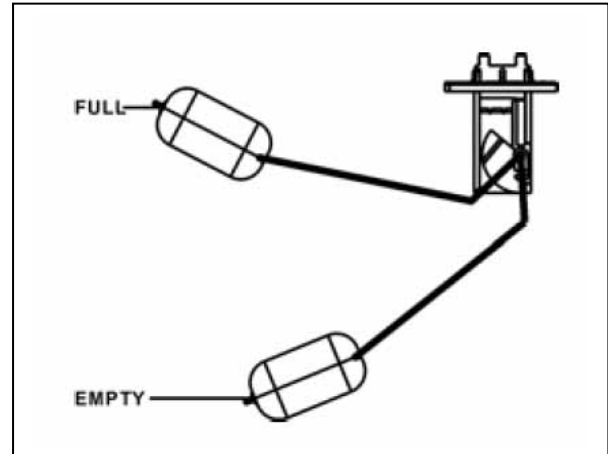

19. LIGHTS/METERS/SWITCHES

SIDE STAND SWITCH INSPECTION

Remove the luggage box.

The side stand switch is located on the side stand.

Disconnect the side stand switch connector.

There should be continuity between the Yellow/Green and Green with the side stand is up.

There should be continuity between the Yellow/Black and Green with the side stand is down.

Side Stand Switch

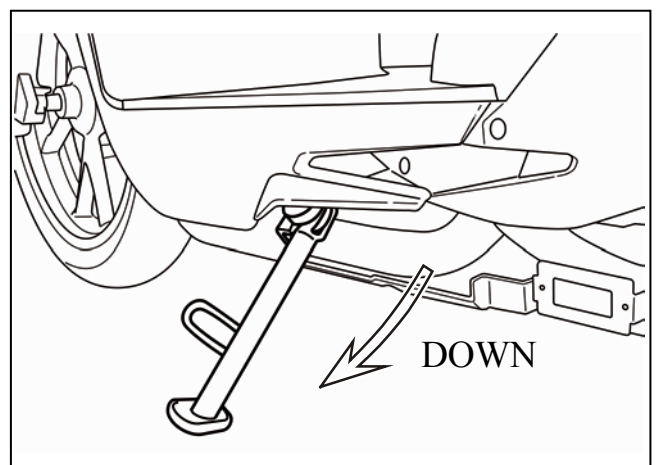
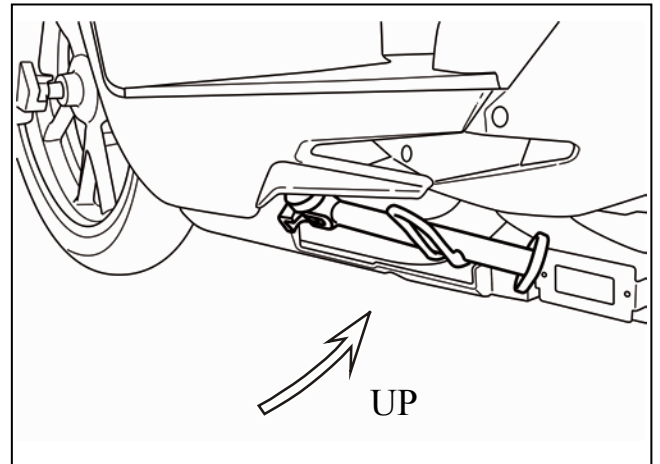
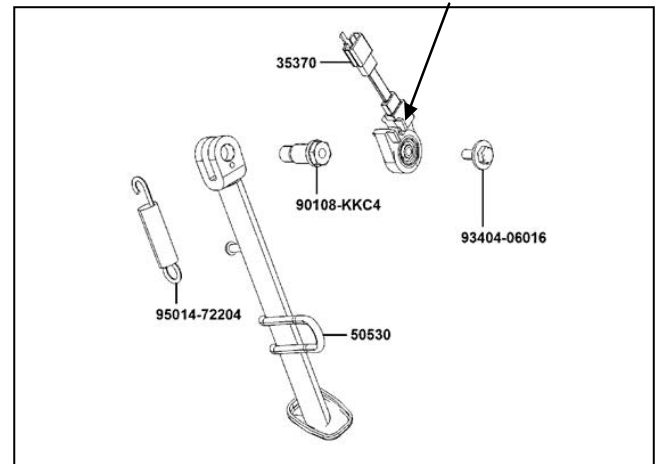

ANTI-LOCK BRAKE SYSTEM (ABS)

ABS Indicator Light-----20 - 1
ABS Introduction-----20 - 2
ABS Parts Location-----20 - 3
Wheel Speed-----20 - 4
ABS ECU & ABS Hydraulic Unit-----20 - 6
ABS ECU Guarantee-----20 - 7
Diagnostic Tool Operation-----20 - 8
Bosch ABS8m DTC List-----20 - 14

ABS Indicator Light

The ABS indicator light in the meter position. This light will come on when the ignition switch is turned on and goes off shortly after the vehicle starts moving at speed 6km/hr min. It stays off.

If something is wrong with the ABS, the indicator comes on and remains on. When the indicator light is on the ABS doesn't function but if the ABS fails, the conventional brake system will still work normally.

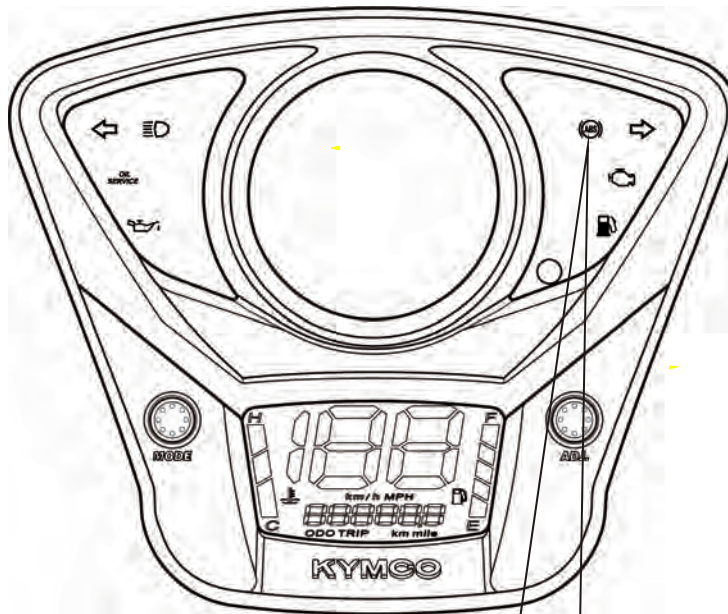

ABS indicator location

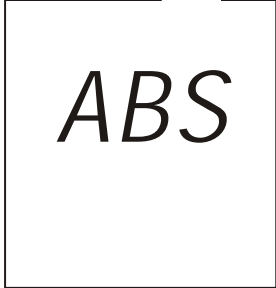

ABS Introduction

ABS is designed to help prevent the wheels from locking up when the brakes are applied hard while running straight. The ABS automatically regulates brake force.

Intermittently gaining gripping force and braking force helps prevent wheel lock-up and allows stable steering control while stopping.

Brake control function is identical to that of conventional vehicle .The brake lever is used for the front brake and rear brake.

Although the ABS provides stability while stopping by preventing wheel lock-up, remember the following characteristics:

- ABS can not compensate for adverse road conditions, misjudgment or improper application of brakes. You must take the same care as with vehicle not equipped with ABS.
- ABS isn't designed to shorten the braking distance. On loose, uneven or downhill surfaces, the stopping distance of a vehicle with ABS may be longer than that of an equivalent vehicle without ABS. Use special caution in such areas.
- ABS will help prevent wheel lock-up when braking in straight line but it cannot control wheel slip, which may be caused by braking during cornering. When turning a corner, it is better to limit braking to the light application of both brakes or not to brake at all. Reduce your speed before you get into the corner.
- The computer could inter-grade in the ABS compare vehicle speed with wheel speed. Since non-recommended tires can affect wheel speed, they may confuse, Which can extend distance.

*** Use of non-recommended tires may cause malfunctioning of ABS and lead to extended braking distance. The rider could have an accident as a result. Always use standard for this recommended vehicle.**

NOTICE:

- When the ABS is functioning, you may feel a pulsing in the brake lever. This is normal. You need not suspend applying brakes.
- ABS does not function at speeds of approx. 10 km/h or below.
- ABS does not function if battery is discharged or battery power supply malfunction. (Light will come on)

Parts Location



Front Wheel speed Sensor Front Wheel speed Sensor Rotor



Front Wheel speed Sensor's connector



Front Wheel speed Sensor Rotor Rear Wheel speed Sensor

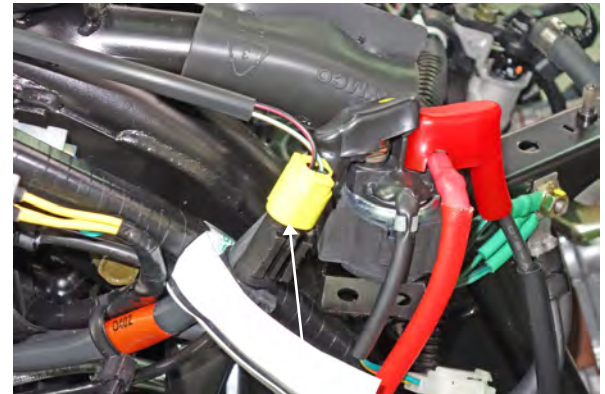

Rear Wheel speed Sensor's connector

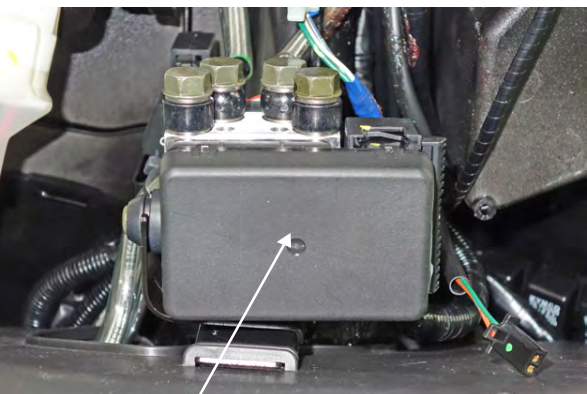

ABS ECU & ABS Hydraulic Unit



ABS diagnosis tool Connector (Near battery position)

WHEEL SENSOR

REMOVAL & INSPECTION

Remove the front wheel speed sensor.
Install the front wheel speed sensor.

Front Wheel Speed Sensor



Front Wheel Speed Sensor Rotor

Remove a bolt attaching to the front wheel speed sensor

Remove the connector of front wheel speed sensor

Front Wheel speed Sensor's connector



※ Standard clearance: Less than 0.8mm between the Front wheel speed sensor and Front Wheel Speed Sensor Rotor



<Front Wheel Speed Sensor>

20 . ANTI-LOCK BRAKE SYSTEM (ABS)

Remove the rear wheel speed sensor.

Rear Wheel Speed Sensor



Front Wheel Speed Sensor Rotor

Remove the connector of rear wheel speed sensor

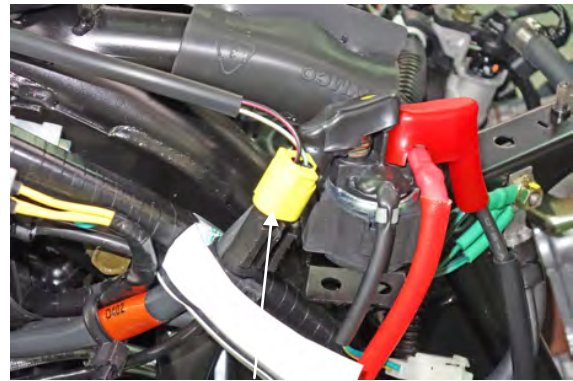

Rear Wheel speed Sensor's connector

※ Standard clearance: Less than 0.8mm
between the Front wheel speed sensor
and Front Wheel Speed Sensor Rotor



<Rear Wheel Speed Sensor>

ABS ECU REMOVAL & INSTALLATION

The coupler is used for automobile's waterproof. Please take care of operation.

Please keep a good ventilating about ECU in order to prevent the ABS ECU from high temperature.

ECU Ventilating Hole

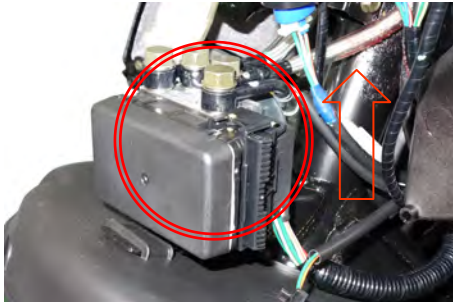

(一) Push upward



(二) Take right out



(三) Finished

ABS ECU & ABS Hydraulic Unit

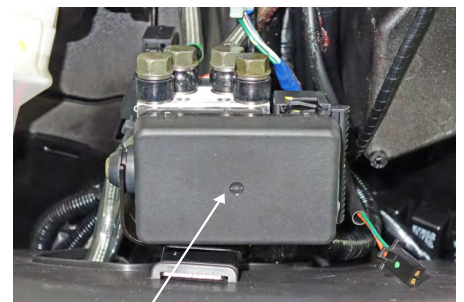

ABS ECU & ABS Hydraulic unit

Remove the screws attaching to the Hydraulic Unit.

To install the sensor is in the reverse order of removal.

(1) Oil bolts X4 Torque: 35N.m (3.5kgf.m)

(2) Nut x 2: 8N.m (0.8 kgf.m)

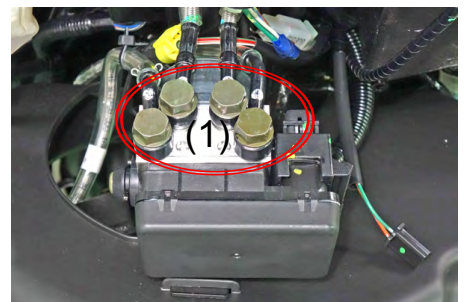

*** When replacing a new Hydraulic Unit, don't need to drain the brake fluid.**

ABS ECU GUARRANTEE:



*** Don't remove four special bolts to take out the ABS ECU. If remove it during the guarantee period. KYMCO can not take a responsibility for it.**

Oil tube bolt 4 * 3.5 kgf-m

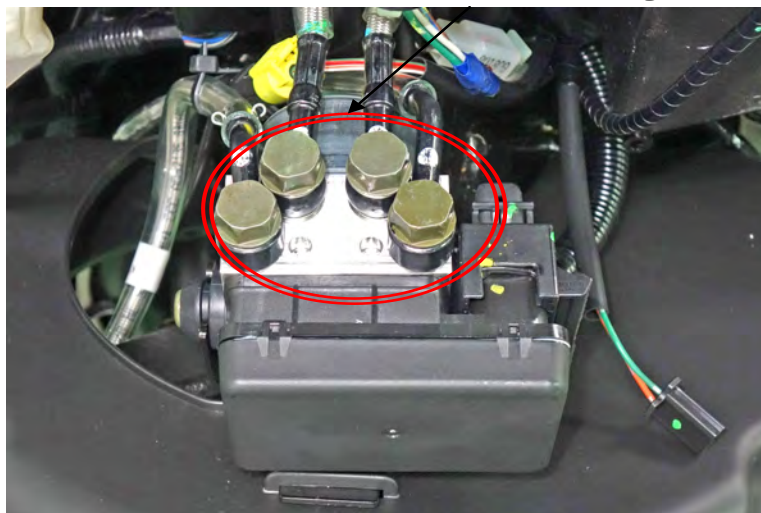

※ Don't need to drain the brake fluid if replace a new ECU Hydraulic unit.

DIAGNOSTIC TOOL OPERATION

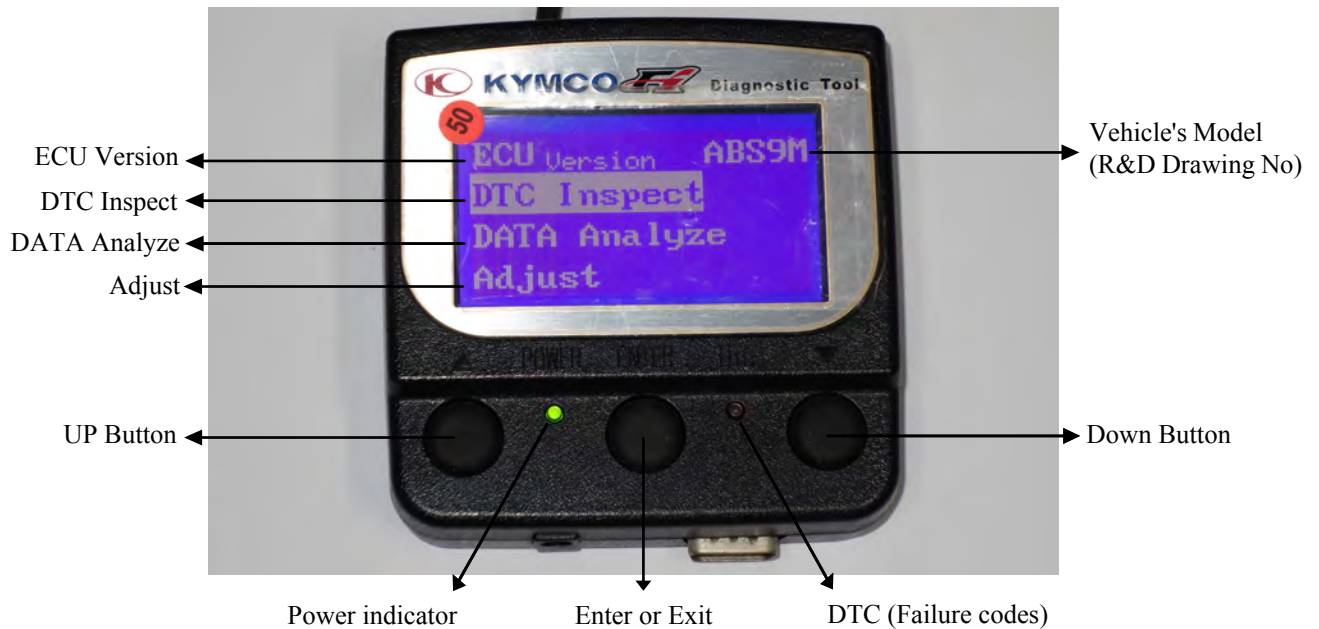

1. Connect the KYMCO Fi Diagnostic tool
2. Put the side stand upward and ENG. stop switch is at "RUN" position.
3. Connect the diagnostic tool connector. (KYMCO Fi Diagnostic tool Power comes from vehicle's Battery)



Self-Diagnostic Tool Connector

20 . ANTI-LOCK BRAKE SYSTEM (ABS)

4. Choose Fi ECU Version and then push down button for three times.



5. Choose No.2 ABS SYS ECU and then push up button to previous.



6. Confirming ECU Version and then enter ABS system.



7. Choose ECU Version and then push “Enter” button.



8. Confirm ABS ECU Version if is LEA7-E00



9. Choose DTC Inspect



10. Load DTC (Active · Occurred · History)

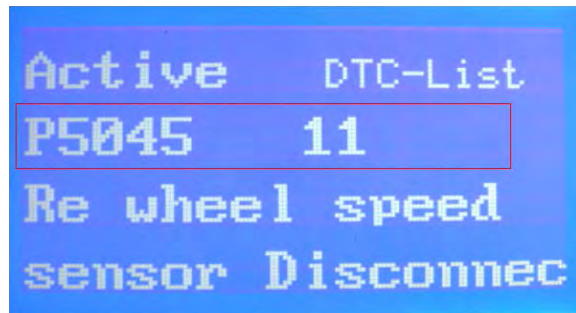
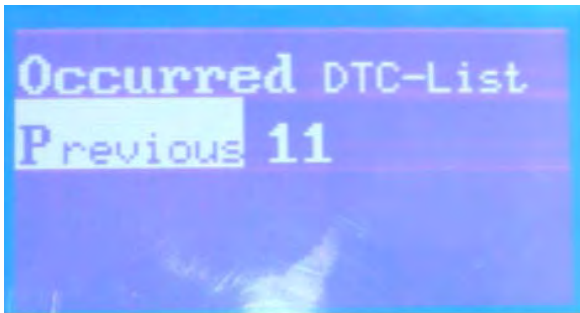
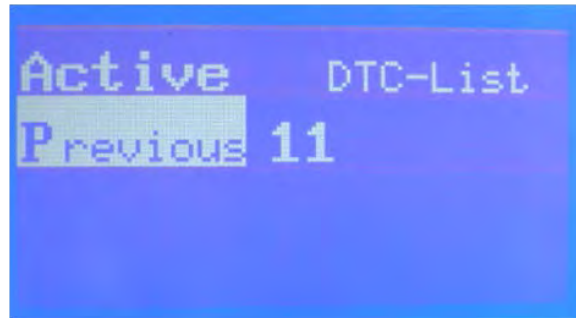
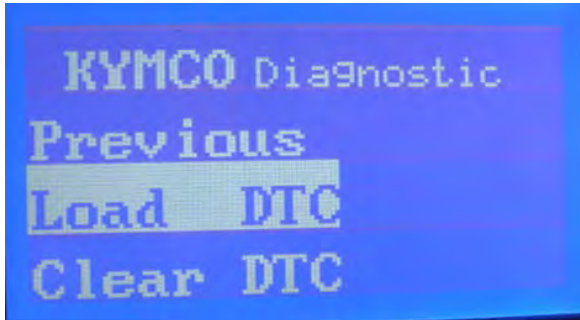

DTC DISPLAYED

1. Rear wheel speed sensor disconnect

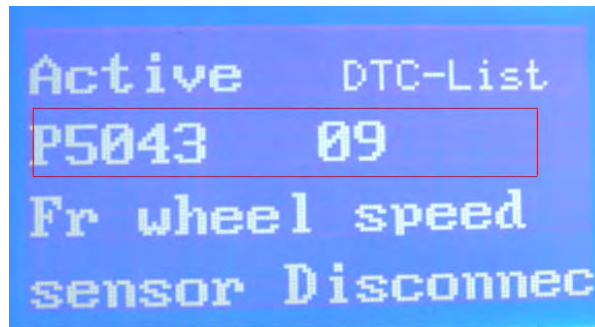

2. Front wheel speed sensor disconnect

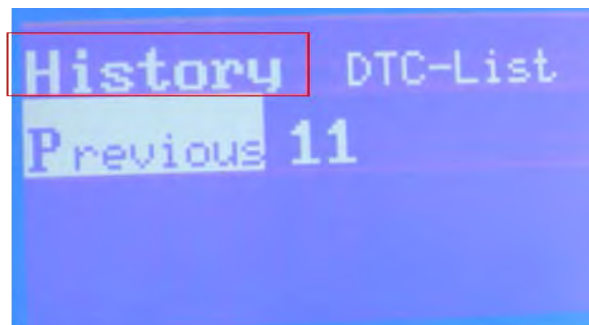

DTC CLEARED

1. Choose “Clear DTC” and then push “Enter” button.



2. Clearing DTC completed until the DTC red lamp is off.



DATA ANALYZE

1. Choose “DATA Analyze” and then push “Enter” button



2. Front wheel speed & Rear wheel speed & Battery volt

Battery volt: Standard 9.6~16.7V

KYMCO Diagnosis 01

Fr Speed 5 km/hr

Re Speed 5 km/hr

Battery Volt 12.6V

* You can turn the front or rear wheel to check if the wheel speed is figured.

Bosch ABS8M DTC List

Bosch ABS9M DTC LIST		
Code NO (Diagnostic Tool) 3620A-LEB2- E00	DTC (PDA)	description
01	5013	Rear Inlet Valve malfunction(EV)
02	5014	Rear Outlet Valve malfunction (AV)
03	5017	Front Inlet Valve malfunction (EV)
04	5018	Front Outlet Valve malfunction (AV)
05	5019	Valve Relay malfunction (Failsafe relay)
06	5025	Deviation between Wheel speeds (WSS_GENERIC)
07	5035	Pump Motor Malfunction
08	5042	Front wheel speed sensor malfunction-Plausibility
09	5043	Front wheel speed sensor Disconnection/gnd Short/Uz Short
10	5044	Rear wheel speed sensor malfunction - Plausibility
11	5045	Rear wheel speed sensor Disconnection/gnd Short/Uz Short
12	5052	Power Supply Malfunction (Under Voltage)
13	5053	Power Supply Malfunction (Over Voltage)
14	5055	ECU malfunction

21 . EEC SYSTEM

21.EEC SYSTEM

This chapter covers the E.E.C system for the KYMCO People S 300 ABS (Euro 5 model only).

E.E.C System Introduction	21- 1
Function	21- 2
Trouble Shooting	21- 2
Maintenance Schedule	21- 3
Air Filter Servicing	21- 5
Maintenance Information	21- 7
Dismantle Of Canister	21- 8
Oxygen Sensor	21- 11

WARNING:

- Before running the engine, make sure that the working area is well ventilated. Never run the engine in a closed area. The exhaust contains poisonous carbon monoxide gas, which may cause death to people.
- Gasoline is extremely flammable and is explosive under some conditions. The working area must be well ventilated and do not smoke or allow flames or sparks near the working area or fuel storage area.

21 . EEC SYSTEM

E.E.C System Introduction:

Evaporative Emission Control System

The evaporative emission control system is used to prevent gasoline vapors from escaping into the atmosphere from the fuel tank and fuel system.

Crankcase Emission Control System

The scooter is equipped with a closed crankcase system. Blow-by gas is recycled into the combustion chamber via the intake system. This arrangement is to prevent blow-by gas from spreading to the atmosphere.

Exhaust Emission Control System

The exhaust emission from the scooter is controlled by combustion management, fuel delivery, ignition setting and exhaust system. The exhaust system also includes the catalytic converter in the muffler.

Noise Exhaust Emission Control System

The engine, intake and exhaust systems of the scooter are designed to comply with federal or local noise regulations. Do not modify the intake or exhaust system, this behavior will offend against the noise regulations.

Note: Do not adapt any original factory design and setting, which will deteriorate the sound or emission level.

Function

Item	Function	Description
Evaporative Emission Control Valve	It is used to prevent gasoline vapors from escaping into the atmosphere from the fuel tank and fuel system.	Storage the gasoline vapors to canister, conduct the gasoline vapors to engine by vacuum when starting the engine.
Canister	Storage the gasoline vapors from fuel tank and fuel system.	The gasoline vapors storage by canister, to meet the regulation, the HC emission can not exceed 2 grams.
P.C.V	Recycle the fuel gas from the crankcase blow by.	Recycle the fuel gas from the crankcase blow by to the engine.
Oxygen Sensor	To control the air/fuel mixture in best condition.	Sending the mixture condition info to ECU by voltage signal, ECU control the fuel injection to meet the emission regulation.
Catalyst	To reduce the emission of HC, CO and NOx produced from the exhaust gas.	Using the catalyst convert the HC and CO to oxygen and reduce the NOx pollution.
ECU	To control the injector, ignition and bypass air of fuel injection system to reach the best driving condition.	ECU (Electric Control Unit), receiving sensor which equipped on engine to precisely control fuel injection and ignition to reduce the exhaust emission pollution.

Trouble Shooting

Low engine power, instable engine idle speed

- Clog in canister or tubes.
- Emission control valve malfunction.
- E.E.C. system tubes loosen or crack.
- ECU malfunction.

Engine idle speed and acceleration in bad condition

- Clog in canister or tubes.
- Emission control valve malfunction.

Maintenance Schedule

Perform the pre-ride inspection at each scheduled maintenance period. This interval should be judged by odometer reading or months, whichever comes first.

Maintenance schedule legend

I: INSPECT AND CLEAN, ADJUST, LUBRICATE OR REPLACE IF NECESSARY

C: CLEAN

R: REPLACE

A: ADJUST

L: LUBRICATE

The maintenance schedule specifies the maintenance required to keep your People S 300 ABS scooter in peak operating condition. Maintenance work should be performed in accordance with KYMCO standards and specifications by properly trained and equipped technicians. Your KYMCO dealer meets all of these requirements.

* Should be serviced by your KYMCO dealer, unless you have the proper tools, service data and are technically qualified.

** In the interest of safety, we recommend these items be serviced only by your KYMCO dealer. KYMCO recommends that your KYMCO dealer road test your scooter after each periodic maintenance service is completed.

FREQUENCY	WHICHEVER COMES FIRST	ODOMETER READING						
		X 1000 km	1	5	10	15	20	25
ITEM	X 1000 mi	0.6	3	6	9	12	15	18
	MONTH	1	6	12	18	24	30	36
*	Air Filter Servicing		R	R	R	R	R	R
	Spark Plug		I	R	I	R	I	R
*	Throttle Free Play		I	I	I	I	I	I
*	Valve Clearance		I	A	I	A	I	A
*	Hose Inspection			I		I		I
	Hose Inspection		C	C	C	C	C	C
*	Engine Oil		R	R	R	R	R	R
*	Engine Oil			C	R	C	R	C
*	Engine Oil		R	R	R	R	R	R
*	Fuel Injection Diagnostic Tool				I		I	
*	Final Drive Oil		R	R	R	R	R	R
*	CVT Removal			I	I	I	I	I
**	CVT Removal				I		I	
	Brake Fluid		I	R	I	R	I	R
	Brake Pad Replacement		I	I	I	I	I	I
	Brakes		I	I	I	I	I	I
*	Switches		I	I	I	I	I	I
	Steering		I	I	I	I	I	I
*	Lights		I	I	I	I	I	I
*	Torque Specifications		I	I	I	I	I	I
**	Wheels/Tires		I	I	I	I	I	I
	Coolant Level Check		I	R	I	R	I	R
*	Canister		I	I	I	I	I	I

21 . EEC SYSTEM

Air Filter Servicing

SAFETY FIRST: Protective gloves and eyewear are recommended at this point.

Replace the air filter according to the [Maintenance Schedule](#), and more often in exceptionally rainy or dusty areas.

Air cleaner element replacement

Remove the screws from the air cleaner cover, then remove air cleaner cover.





Remove screws from the air cleaner element , then remove and discard this air cleaner element.

The new air cleaner element installation is in the reverse order of removal.

Use the KYMCO genuine air cleaner element or an equivalent air cleaner element specified for your model. Using the wrong KYMCO air cleaner element or a non-KYMCO air cleaner element which is not of equivalent quality may cause premature engine wear or performance problems.

Remove the air filter from the airbox. Discard the air filter in favor of a new item.

Caution:

- The air cleaner element has a viscous type paper element. Do not clean it with compressed air.
- Be sure to install the air cleaner element and cover securely.

Maintenance Information

Note of maintenance:

- Install the tubes in correct position.
- If the tubes broken should be replaced with a new one.
- The tubes should be installed tightly.
- The leakage hole should be installed downward.

Tool

- Vacuum pump
- Pressure pump

Maintenance standard

- Emission vacuum standard: 45m/mHg
- Capacity of canister: 90cc
- Install angle: incline 60°

Evaporative Emission Control System

The location of tube connection diagram.

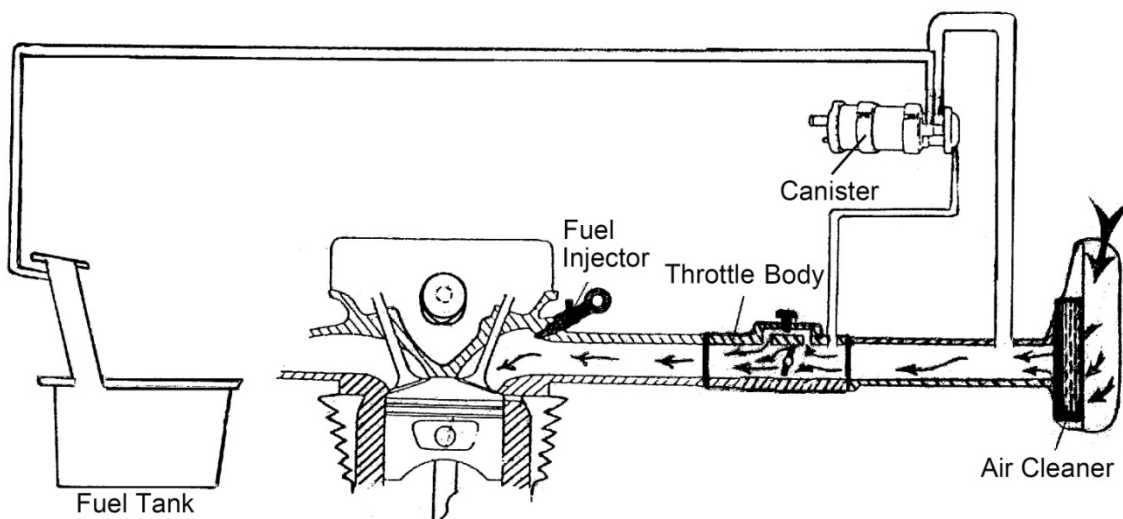

Leakage checking

1. Connection between canister and fuel tank.
2. Tubes of canister.

21 . EEC SYSTEM

Dismantle of Canister

- 1.Dismantle the body cover.
- 2.Dismantle the canister tube set and canister.



Canister

Inspection of canister evaporative control valve

Connecting a vacuum pump to the tube of canister. (Follow the illustration below.)

Applying 250m/mHg pressure to the canister evaporative control valve.

If the pressure will be kept without change obviously in one minute, that means the valve are with good condition, otherwise the valve malfunction, a new canister should be replaced.

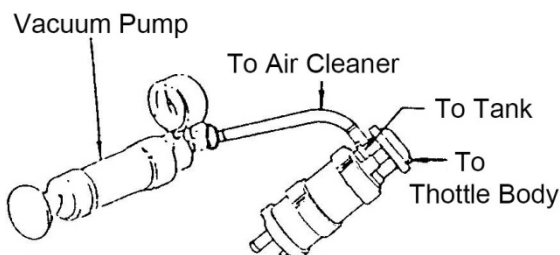

Connecting a vacuum pump to the tube of canister. (Follow the illustration below.)

Applying 45m/mHg vacuum pressure to the canister evaporative control valve.

If the pressure will be kept without change obviously in one minute, that means the valve are with good condition, otherwise represents the valve with malfunction. A new canister should be replaced.

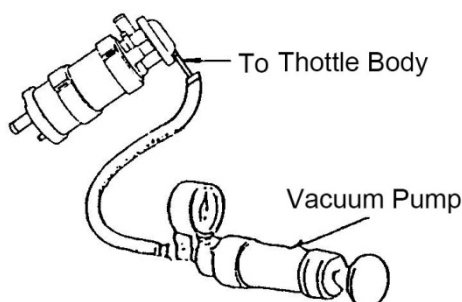

21 . EEC SYSTEM

Inspection of the flow rate of the canister vacuum valve

1. Using a vacuum pump connecting to the vacuum tube of canister and apply 45m/mHg of negative pressure.
2. Apply pressure to the emission control valve of canister, if the flow rate above 9.4 liters per minute that means the valve is in good condition, otherwise the canister should be replaced.

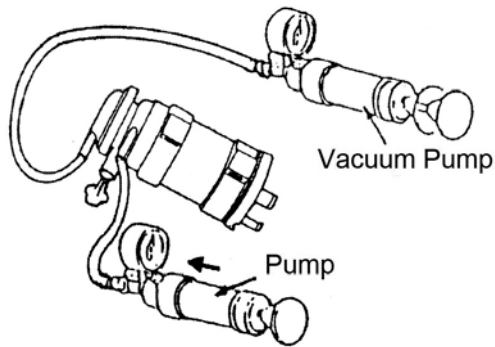

NOTE: Always using the pump by manual, do not apply high pressure for testing to prevent the valve from malfunction.

Installation of canister

1. Installation is the reverse order to the dismantling.
2. Connect the tubes and circlips firmly.



NOTE: The tube should not be wrenched or crashed and never refit the canister.

21 . EEC SYSTEM

P.C.V. Dismantle

- 1.Dismantle the cover of air cleaner.
- 2.Dismantle the P.C.V cover.
- 3.P.C.V , if there is oil in the red drain tube, it should be cleaned.

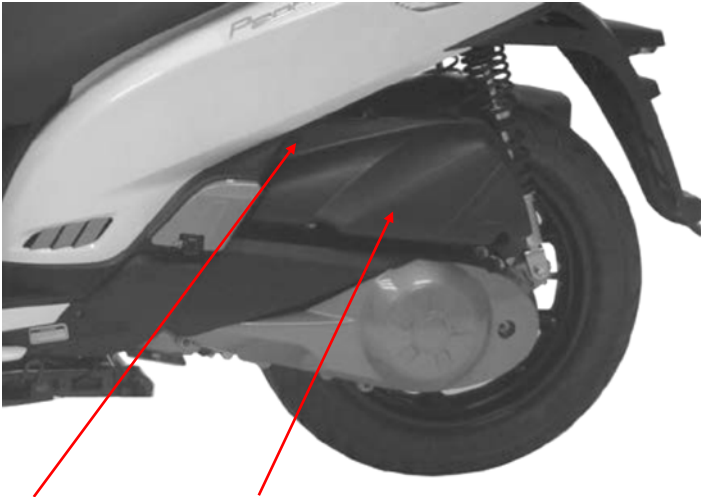

P.C.V

Air Cleaner

Inspection of emission system

- Clean or replace the air cleaner.
- Inspection of the spark plug.
- Inspection of the ignition system.
- Plug in the diagnostic tool the check the information.
- Warm up the engine reach above 80°C.

This model equipped the catalyst in the muffler to reduce the pollution emission.

Inspection Of Catalyst Converter

- Inspection of catalyst converter efficiency at idle speed.
- Warm up the engine 8~10 minutes, connect to emission machine.
- To check the CO value before catalyst and after.
- Normally, measuring after catalyst converting, the CO figure will be lower than the CO figure before catalyst converting.
- If the number is abnormal, the catalyst converter could be deteriorated, the exhaust pipe should be replaced to prevent from the further pollution.

21 . EEC SYSTEM

Oxygen Sensor

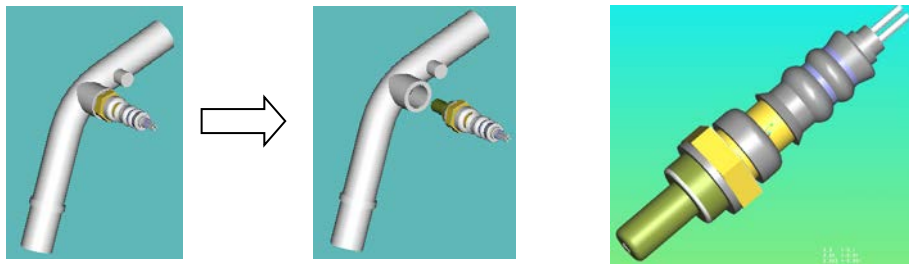

It uses DC-8-16V Battery Power with 4 pins: one power pin, one heater pin, one signal output pin and one earthing pin. The sensor is installed to the front pipe of exhaust pipe to detect the oxygen concentration of exhaust gas for determining if ECU shall instruct to increase or reduce fuel supply for meeting waste gas emission standard of environment legislation. When the temperature of exhaust is less than 350°C , the sensing portion can not be activated and there is no signal output, and ECU will turn on the heater inside sensor to accelerate the temperature rise of sensor and cause the Oxygen Sensor to work normally. In normal hours, the impedance of heater is 7.7 ± 1.2 ohm and can be told with multimeter. Output of sensor after the engine is warmed up is

A/F < 14.7 (mixing ratio too thick) $> 0.7\text{V}$

A/F > 14.7 (Mixing ratio too thin) $< 0.18\text{V}$

Inspection and adjustment of emission

1. Start the engine and warm up for several minutes engine temperature $80\sim 90^{\circ}\text{C}$, connect the diagnostic tool to check the information.
2. Idle speed should be in standard.
3. The emission machine should be connected to the front of the exhaust pipe measure hole. (Before Catalyst Converter)
4. Standard : CO: $0.3\sim 1.5\%$
5. If the figure is out of range, check with the injection relative components. (For example, injector, fuel pump...etc.)
6. If the problem insist, please check the emission related system and check if there is any leakage from the cylinder head inlet/outlet valve.