

8. CYLINDER HEAD/VALVES

CYLINDER HEAD/VALVES

SCHEMATIC DRAWING -----	8- 1
SERVICE INFORMATION-----	8- 2
TROUBLESHOOTING-----	8- 3
CYLINDER COMPRESSION TEST -----	8- 4
CYLINDER HEAD COVER REMOVAL/INSTALLATION-----	8- 5
CYLINDER HEAD COVER DISASSEMBLY/ASSEMBLY-----	8- 6
CAMSHAFT REMOVAL/INSPECTION/INSTALLATION -----	8- 7
ROCKER ARMS REMOVAL/INSPECTION/INSTALLATION ----	8-15
CYLINDER HEAD REMOVAL/INSTALLATION-----	8-17
CYLINDER HEAD DISASSEMBLY/INSPECTION/ASSEMBLY -	8-24
CAM CHAIN REMOVAL/INSPECTION/INSTALLATION -----	8-28

8. CYLINDER HEAD/VALVES

SCHEMATIC DRAWING

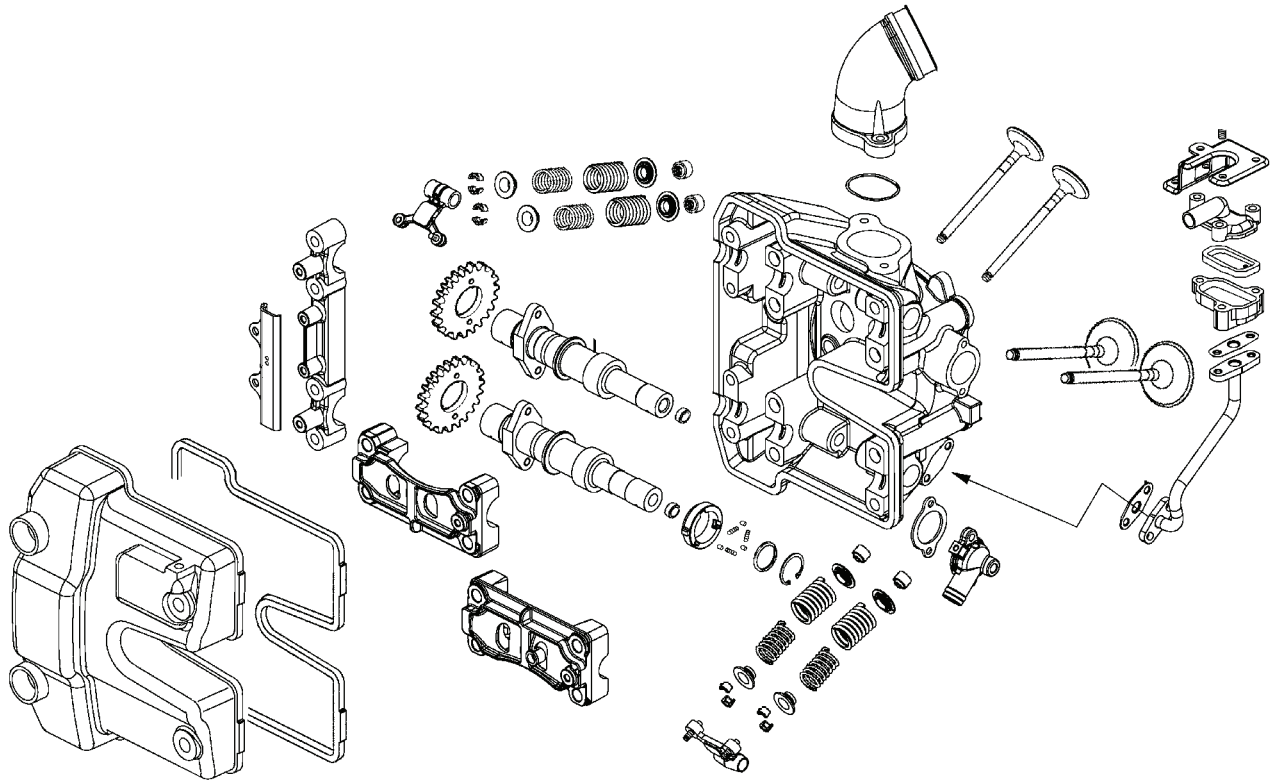

8. CYLINDER HEAD/VALVES

SERVICE INFORMATION

GENERAL INSTRUCTIONS

- The cylinder head can be serviced with the engine installed in the frame. Coolant in the radiator and water jacket must be drained first.
- When assembling, apply molybdenum disulfide grease or engine oil to the valve guide movable parts and valve arm sliding surfaces for initial lubrication.
- The valve rocker arms are lubricated by engine oil through the cylinder head engine oil passages. Clean and unclog the oil passages before assembling the cylinder head.
- After disassembly, clean the removed parts and dry them with compressed air before inspection.
- After removal, mark and arrange the removed parts in order. When assembling, install them in the reverse order of removal.

SPECIFICATIONS

Unit: mm

Item		Standard	Service Limit
Valve clearance (cold)	IN	0.1 mm	—
	EX	0.1 mm	—
Cylinder head compression pressure		15 kg/cm²	—
Cylinder head warpage		—	0.05
Camshaft runout		—	0.05
Camshaft cam height	IN	37.2614	37.11
	EX	37.0084	36.86
Valve rocker arm I.D.	IN	10 ~10.015	10.1
	EX	10 ~10.015	10.1
Valve rocker arm shaft O.D.	IN	9.975 ~9.99	9.9
	EX	9.975~9.99	9.9
Rocker arm to shaft clearance		0.009 ~0.042	0.1
Valve stem O.D.	IN	4.975 ~4.99	4.925
	EX	4.955 ~4.97	4.915
Valve guide I.D.	IN	5 ~5.015	5.03
	EX	5 ~5.015	5.03
Valve stem-to-guide clearance	IN	0.01 ~0.037	0.08
	EX	0.03 ~0.057	0.1

8. CYLINDER HEAD/VALVES

TORQUE VALUES

Cylinder head bolt (1 – 4)	4.8 kgf-m (48 N-m)	Apply engine oil to threads
Cylinder head bolt (5 – 13)	2.3 kgf-m (23 N-m)	Apply engine oil to threads
Cylinder head nut	1 kgf-m (10 N-m)	
Cylinder head cover bolt	1 kgf-m (10 N-m)	
Breather separator bolt	1.3 kgf-m (13 N-m)	
Cam chain tensioner bolt	1.2 kgf-m (12 N-m)	
Tensioner sealing bolt	1 kgf-m (10 N-m)	
Rocker arm shaft	4.5 kgf-m (45 N-m)	
Cam chain guide pivot bolt	2 kgf-m (20 N-m)	
Water joint bolt	1.2 kgf-m (12 N-m)	

SPECIAL TOOLS

Valve spring compressor	A120E00040
-------------------------	------------

TROUBLESHOOTING

- The poor cylinder head operation can be diagnosed by a compression test or by tracing engine top-end noises.

Poor performance at idle speed

- Compression too low

Compression too low

- Incorrect valve clearance adjustment
- Burned or bend valves
- Incorrect valve timing
- Broken valve spring
- Poor valve and seat contact
- Leaking cylinder head gasket
- Warped or cracked cylinder head
- Poorly installed spark plug

Compression too high

- Excessive carbon build-up in combustion chamber

White smoke from exhaust muffler

- Worn valve stem or valve guide
- Damaged valve stem oil seal

Abnormal noise

- Incorrect valve clearance adjustment
- Sticking valve or broken valve spring
- Damaged or worn camshaft
- Worn cam chain tensioner
- Worn camshaft and rocker arm

8. CYLINDER HEAD/VALVES

CYLINDER COMPRESSION TEST

Warm up the engine to normal operating temperature.
Stop the engine and remove the spark plug cap and remove the spark plug (refer to the “SPARK PLUG” section in the chapter 3).

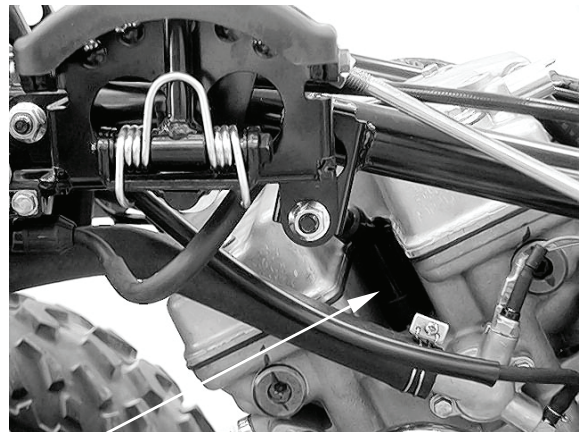

Park Plug Cap

Install a compression gauge into the spark plug hole.

Open the throttle all the way and crank the engine with the starter motor until the gauge reading stops rising.

The maximum reading is usually reached 4 – 7 seconds.

* To avoid discharging the battery, do not operate the starter motor for more than seven seconds.

Compression Gauge

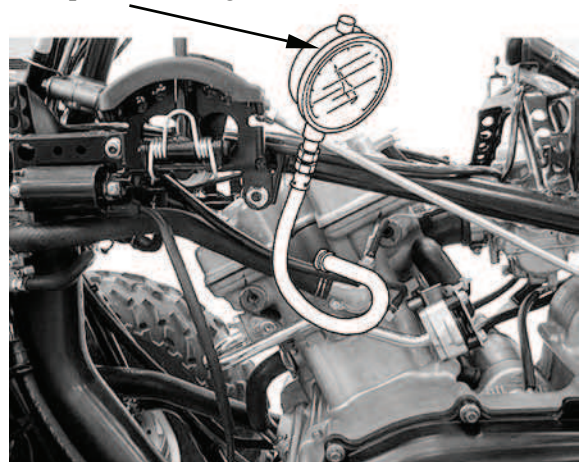

Compression pressure:

15 kg/cm² (1500 kPa, 213 psi)

Low compression can be caused by:

- ♦ Blown cylinder head gasket
- ♦ Improper valve adjustment
- ♦ Valve leakage
- ♦ Worn piston ring or cylinder

High compression can be caused by:

- ♦ Carbon deposits in combustion chamber or on piston head

8. CYLINDER HEAD/VALVES

CYLINDER HEAD COVER REMOVAL/INSTALLATION

REMOVAL

Disconnect the crankcase breather hose from the cylinder head cover (refer to the “ENGINE REMOVAL” section in the chapter 7).

Remove the four bolts/rubber washers and cylinder head cover.

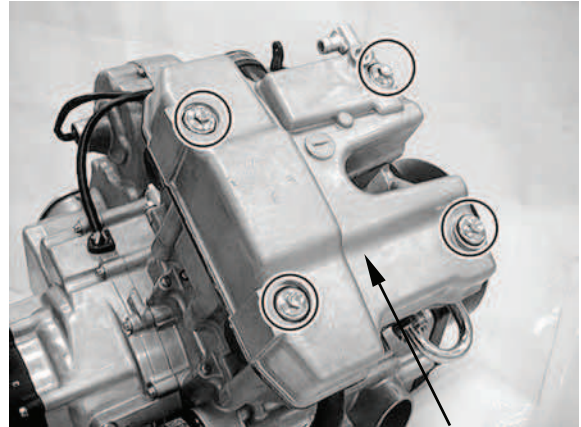

Cylinder Head Cover

Remove the cylinder head cover packing.

INSTALLATION

Apply fluid gasket (threebond: 1215) to the mating surface of the cylinder head cover, then install the packing.

Cylinder Head Cover Packing

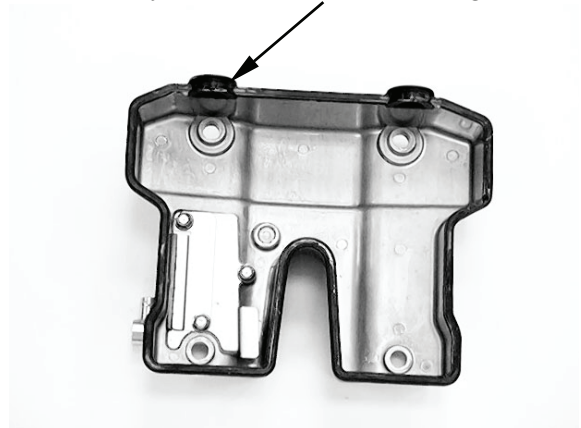

Install the cylinder head cover.
Install and tighten the four bolts/rubber washers to the specified torque in a crisscross pattern.

Torque: 1 kgf-m (10 N-m)

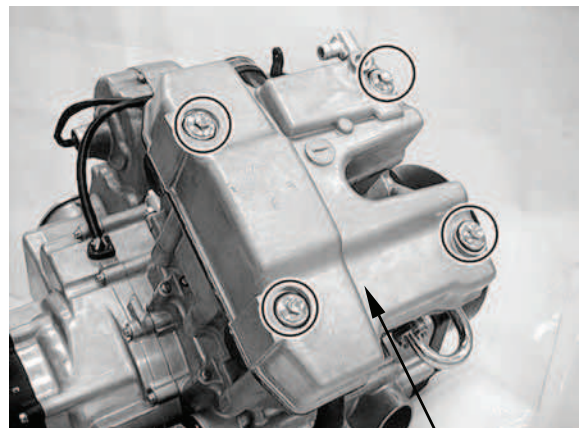

Cylinder Head Cover

8. CYLINDER HEAD/VALVES

CYLINDER HEAD COVER DISASSEMBLY/ASSEMBLY

DISASSEMBLY

Remove the three bolts and breather separator.



Remove the gasket.

ASSEMBLY

Assembly is in the reverse order of disassembly.

Torque:

Breather separator bolt:

1.3 kgf-m (13 N-m,)

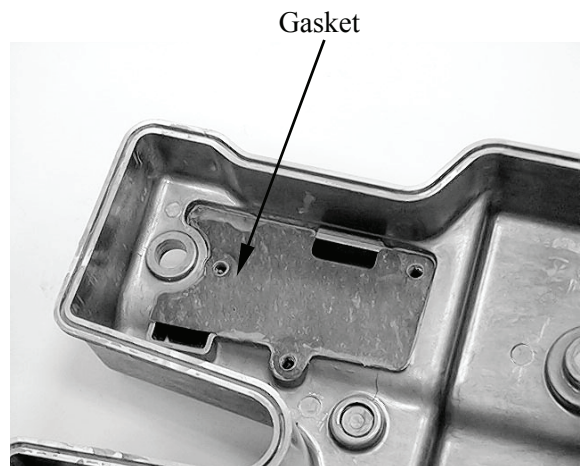

8. CYLINDER HEAD/VALVES

CAMSHAFT REMOVAL/INSPECTION/ INSTALLATION

REMOVAL

Remove the cylinder head cover (refer to the “**CYLINDER HEAD COVER REMOVAL/INSTALLATION**” section in this chapter).

Turn the crankshaft clockwise and align the “T” mark on the flywheel with the index mark on the right crankcase cover (refer to the “**VALVE CLEARANCE**” section in the chapter 3).

Remove the cam chain tensioner lifter sealing bolt, spring and sealing washer.

Remove the two bolts, cam chain tensioner and gasket.

Remove the two bolts and cam chain guide.

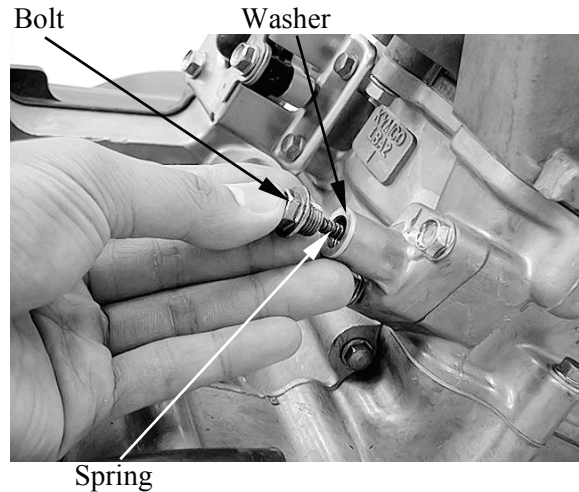

Cam Chain Tensioner/Gasket

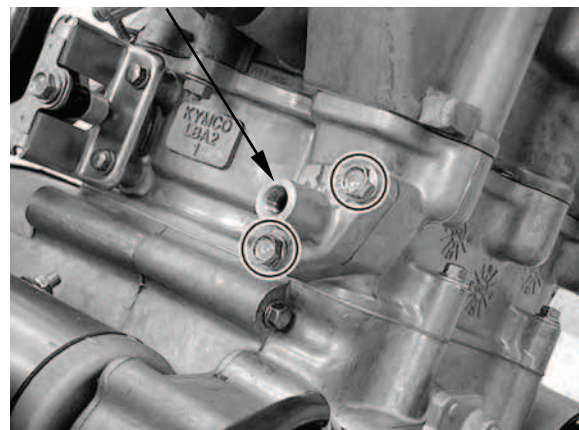

Cam Chain Guide

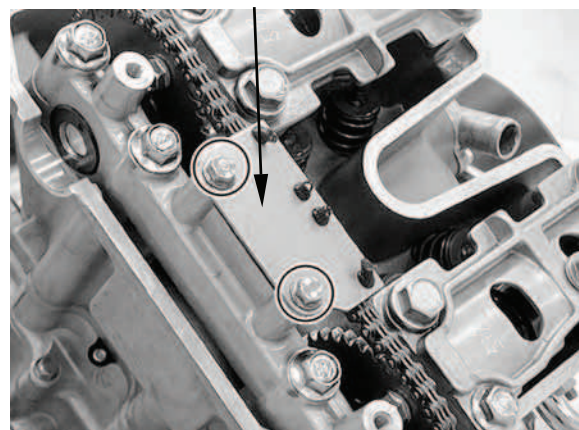

8. CYLINDER HEAD/VALVES

Loosen and remove the eight camshaft holder bolts in a crisscross pattern in several steps.

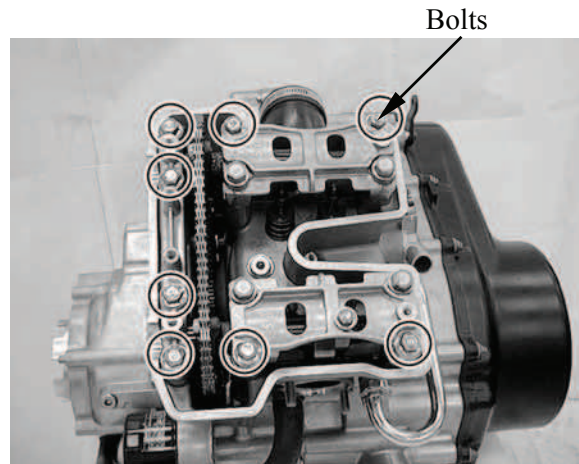

Loosen and remove the four camshaft holder bolts/washers in a crisscross pattern in several steps, then remove the camshaft holders.

* Suspend the cam chain with a piece of wire to prevent the chain from falling into the crankcase.

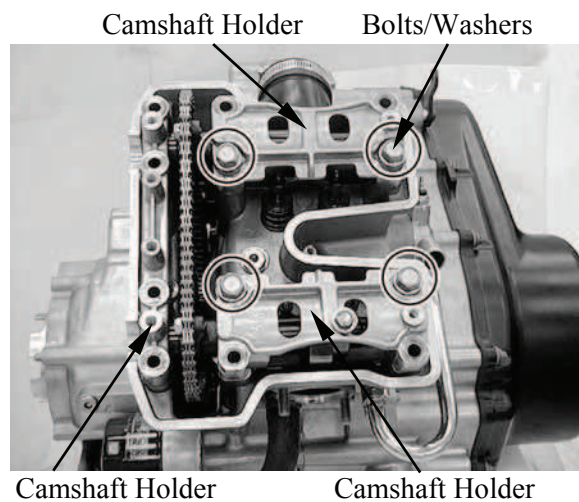

Remove the camshafts.

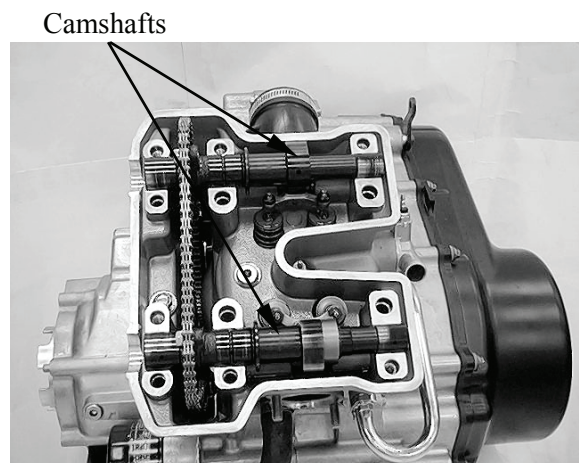

8. CYLINDER HEAD/VALVES

INSPECTION

Cam chain guide

Inspect the cam chain slipper surface of the cam chain guide for wear or damage.

Cam Chain Slipper

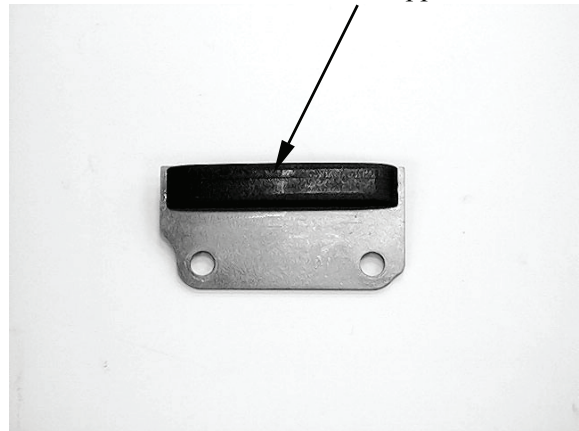

Camshaft holder

* Always replace the camshaft holder and cylinder head in pairs

Inspect the camshaft surface of each camshaft holder for scoring, scratches, or evidence of insufficient lubrication.

Camshaft Holders

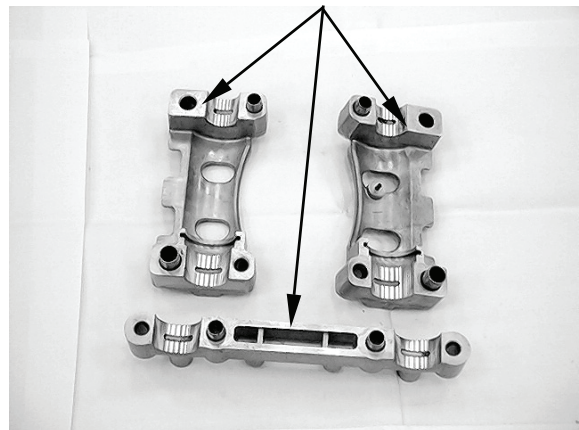

Check the stop pin spring on the exhaust camshaft holder for damage.

Replace the stop pin assembly with a new one if the spring is damaged.

Stop Pin

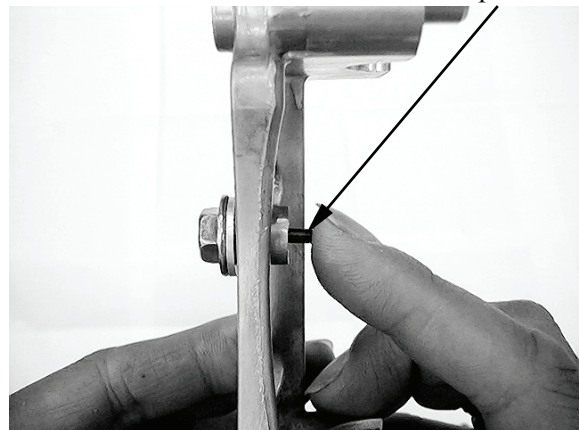

8. CYLINDER HEAD/VALVES

Camshaft

Support both ends of the camshaft with V-blocks and check the camshaft runout with a dial gauge.

Service limit: 0.05 mm

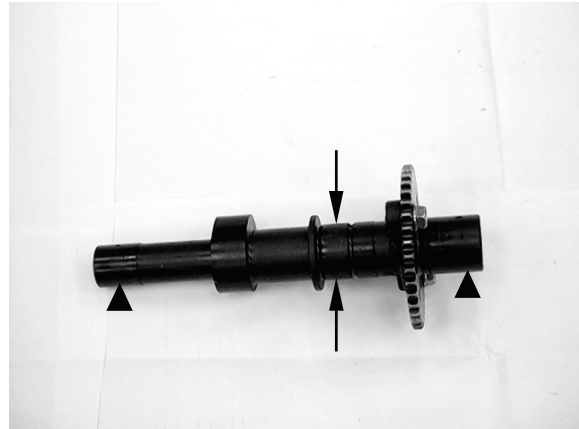

Inspect camshaft lobes for pitting/scratches/blue discoloration.

Measure the cam lobe height.

Service Limits: IN : 37.11 mm
EX: 36.86 mm

If any defects are found, replace the camshaft with a new one, then inspect lubrication system.

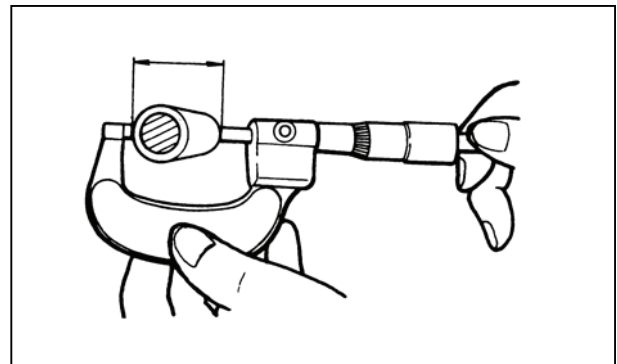

Check the decompression system by turning the decompressor cam on the exhaust camshaft.

You should be able to turn the decompressor cam clockwise smoothly, but the decompressor should not turn counterclockwise.



8. CYLINDER HEAD/VALVES

Cam chain tensioner

Check the one-way cam operation (tensioner)
Unsmooth operation → Replace.



INSTALLATION

Turn the crankshaft clockwise, align the “T” mark on the flywheel with the index mark on the right crankcase cover (refer to the “VALVE CLEARANCE” in chapter 3).

Apply molybdenum disulfide oil to the camshaft journals of the camshaft holder.

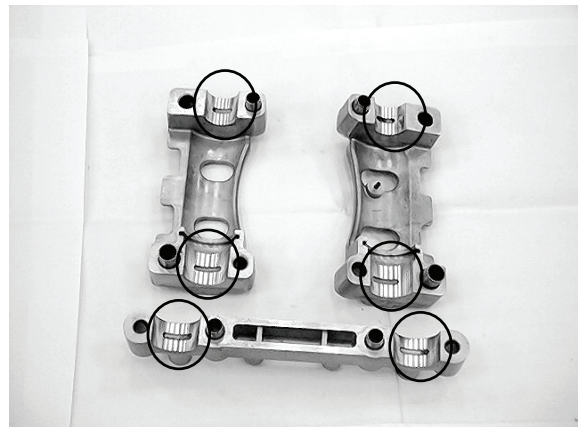

Apply molybdenum disulfide oil to the camshaft journals of the cylinder head.

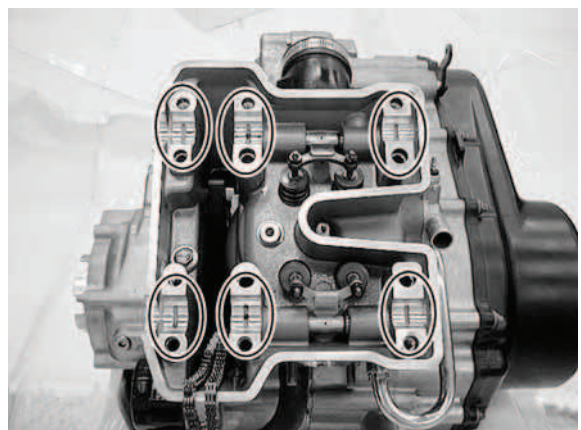

8. CYLINDER HEAD/VALVES

Install the cam chain over the cam sprockets and then install the intake and exhaust camshafts.

- *
 - ◆ Install each camshafts to the correct locations.
 - “IN”: no decompressor cam
 - “EX”: has a decompressor cam
 - ◆ Make sure the timing marks on the cam sprockets are flush with the cylinder head upper surface and punch marks face upward as shown.

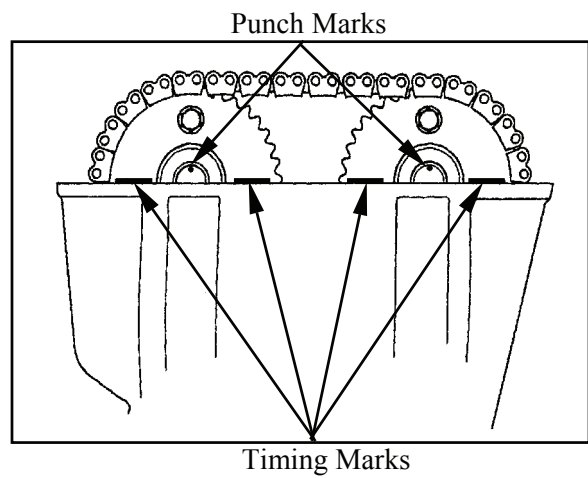

Install intake and exhaust camshaft holders to the correct locations.

- ◆ Install each camshaft holders to the correct locations.
 - “IN”: no stop pin.
 - “EX”: has a stop pin.

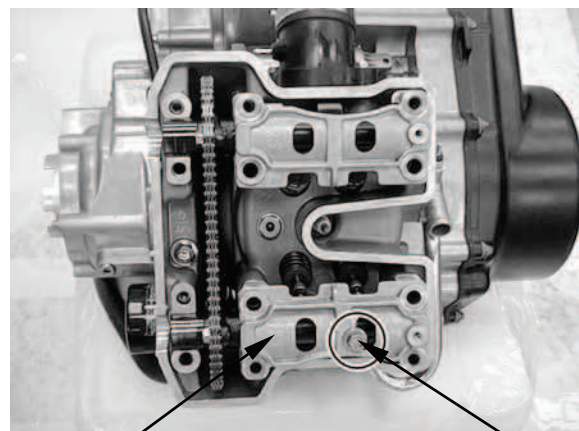

Exhaust Camshaft Holder

Stop Pin

8. CYLINDER HEAD/VALVES

Apply engine oil to cylinder head bolt (No. 1 – 8) threads.

Install the four bolts (No. 5 – 8).

Install the four bolts/washers (No. 1 – 4).

Tighten the holder bolts (No. 1 – 8) in a crisscross pattern in five steps to the specified torque as follow diagram.

Tighten the bolts to the specified torque in sequence									
kgf-m (N-m, lbf-ft)									
	(1)	(2)	(3)	(4)	(5)	(6)	(7)	(8)	
Step 1	2.4 (24, 17)	←	←	←	1.2 (12, 9)	←	←	←	
Step 2	3.8 (38, 27)	←	←	←	2.3 (23, 17)	←	←	←	
Step 3	4.8 (48, 35)	←	←	←					

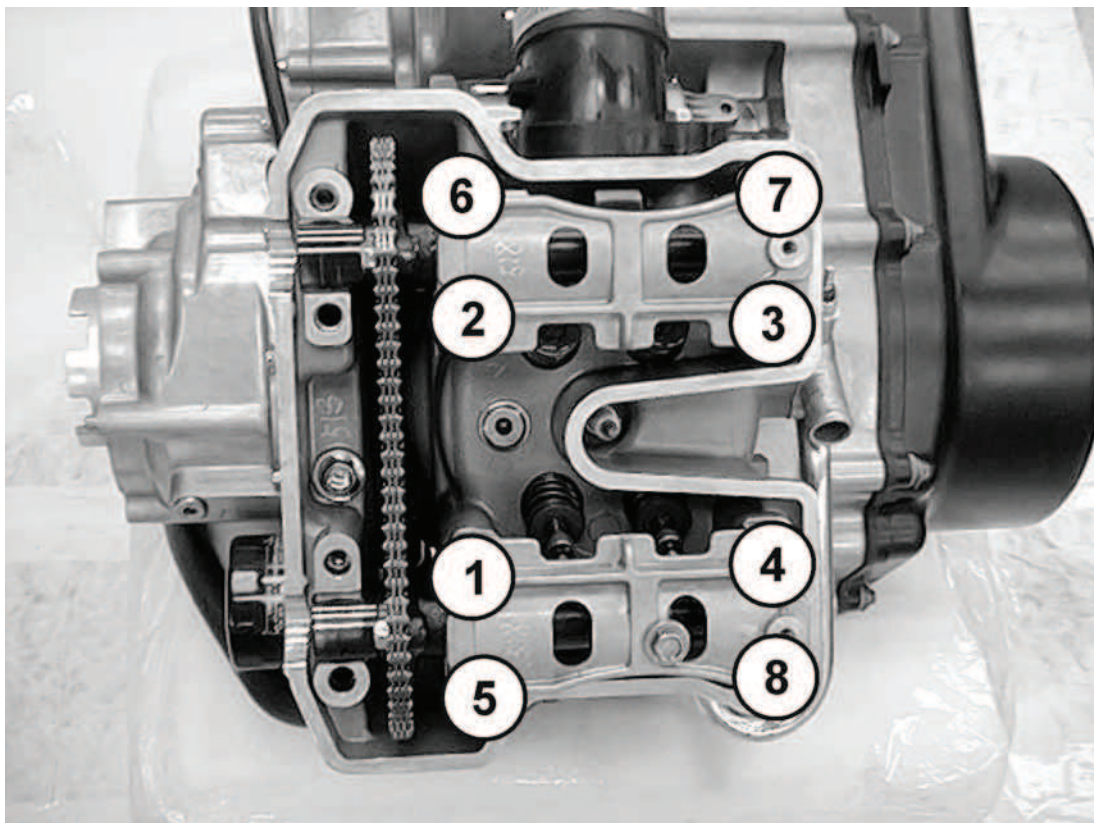

8. CYLINDER HEAD/VALVES

Apply engine oil to cylinder head bolt (No. 10 – 13) threads.

Install the common camshaft holder by arrow mark facing outside.

Install and tighten the holder bolts (No. 10 – 13) in a crisscross pattern in five steps to the specified torque as follow diagram.

Tighten the bolts to the specified torque in sequence								
kgf-m (N-m)								
	(10)	(11)	(12)	(13)				
Step 4	1.2 (12)	←	←	←				
Step 5	2.3 (23)	←	←	←				

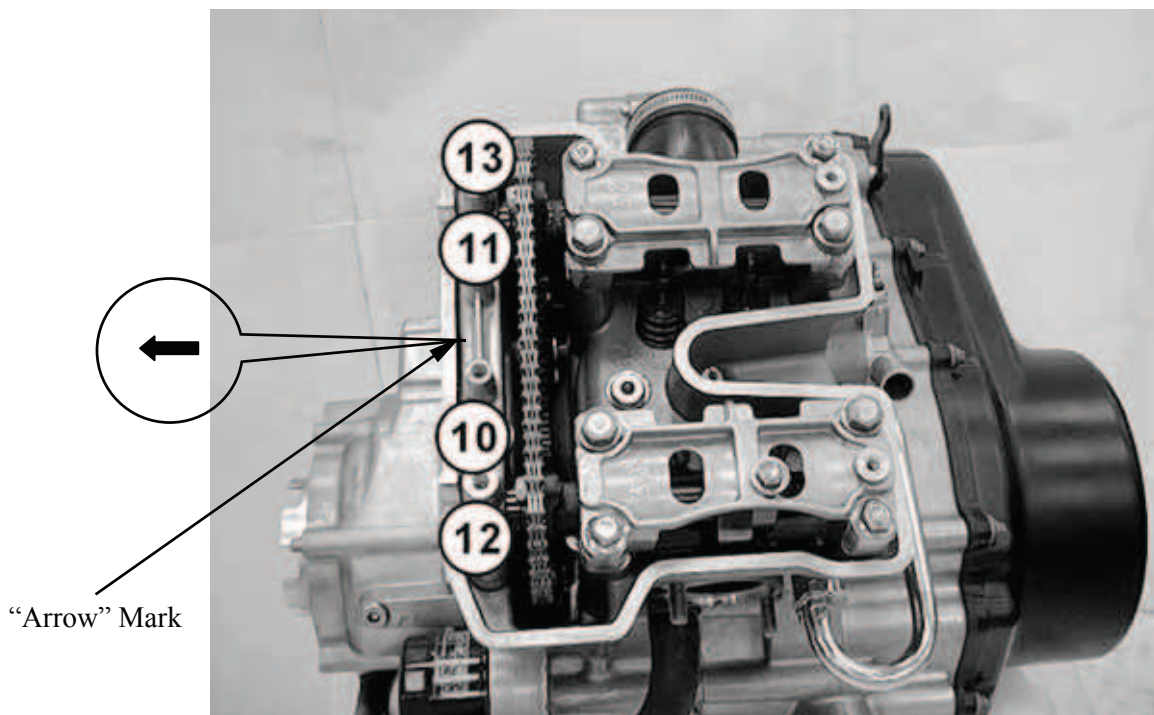

8. CYLINDER HEAD/VALVES

ROCKER ARMS REMOVAL/INSPECTION/ INSTALLATION

REMOVAL

Remove the camshafts (refer to the “CAMSHAFT REMOVAL/INSPECTION/INSTALLATION” section in this chapter).

Remove the rocker arm shafts and washers, then remove the rocker arms.

Rocker Arms

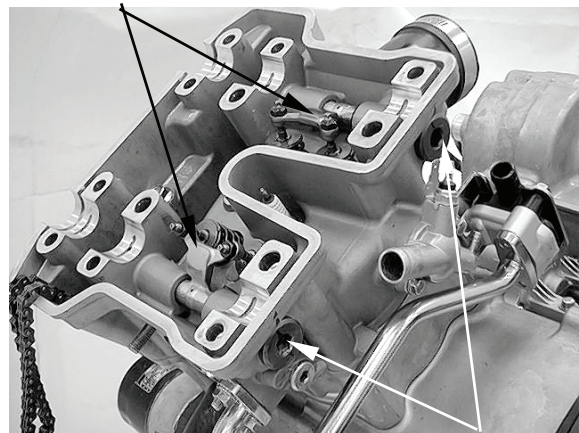

Rocker Arm Shafts/Washers

INSPECTION

Rocker arm shaft

Inspect the rocker arm shaft for blue discoloration or grooves.

If any defects are found, replace the rocker arm shaft with a new one, then inspect lubrication system.

Measure each rocker arm shaft O.D.

Measure the I.D. of each rocker arm.

Measure arm to shaft clearance.

Replace as a set if out of specification.

Service limits: 0.1 mm

Inspect the rocker arm bore, cam lobe contact surface and adjuster surface for wear/pitting/scratches/blue discoloration.

If any defects are found, replace the rocker arm shaft with a new one, then inspect lubrication system.

Measure each rocker arm shaft O.D.

Measure the I.D. of each rocker arm.

Measure arm to shaft clearance.

Replace as a set if out of specification.

Service limits: 0.1 mm

Rocker Arm Shaft

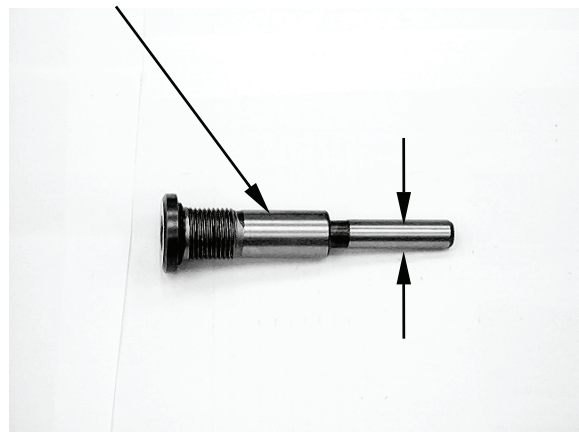

Rock Arm

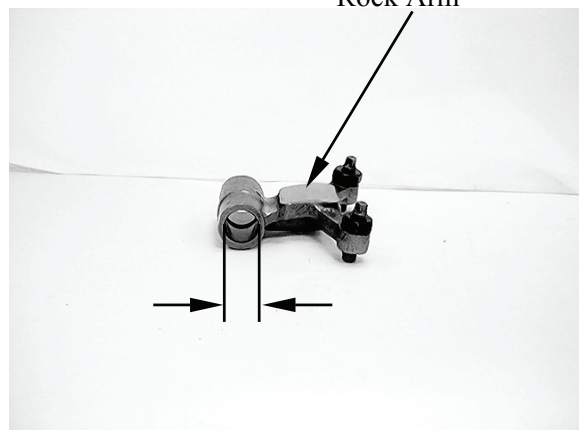

8. CYLINDER HEAD/VALVES

INSTALLATION

Apply engine oil to the rocker arms and rocker arm shafts

Install the rocker arms, rocker arm shafts and washers.
Tighten the rocker arm shaft to the specified torque.

Torque: 4.5 kgf-m (45 N-m, 32 lbf-ft)

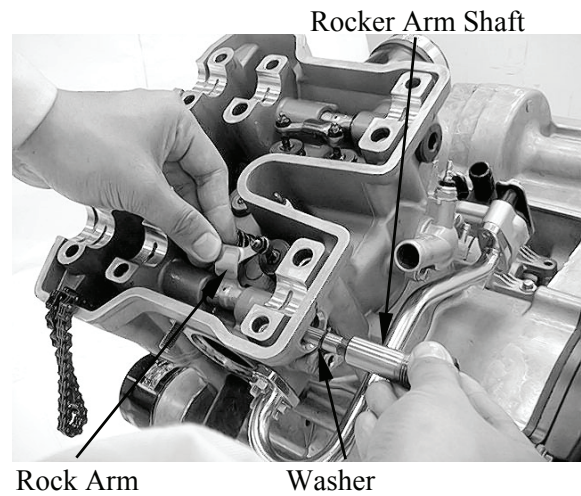

8. CYLINDER HEAD/VALVES

CYLINDER HEAD REMOVAL/INSTALLATION

* Always replace the camshaft holder and cylinder head in pairs

Remove the camshafts (refer to the “CAMSHAFT REMOVAL/INSPECTION/INSTALLATION” section in this chapter)

Remove the two bolts and intake pipe.

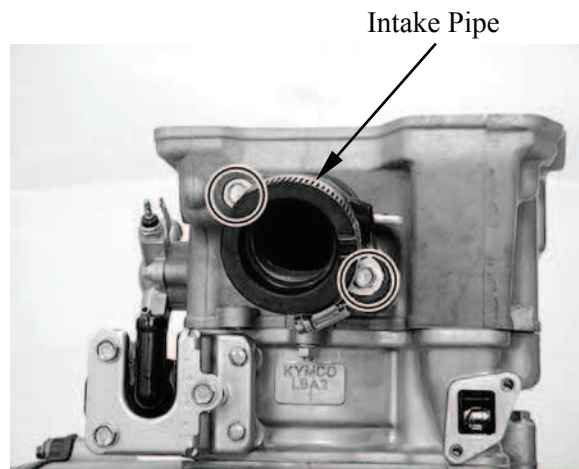

Remove the five bolts, then remove the pair reed valve cover and holder.

Remove the two nuts, then remove the pair reed valve and gasket.

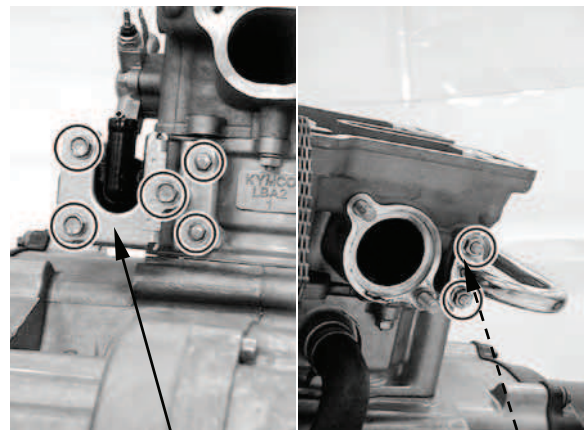

Pair Reed Valve Cover/Holder

Gasket

Remove the two bolts, water joint, gasket and water stop collar.

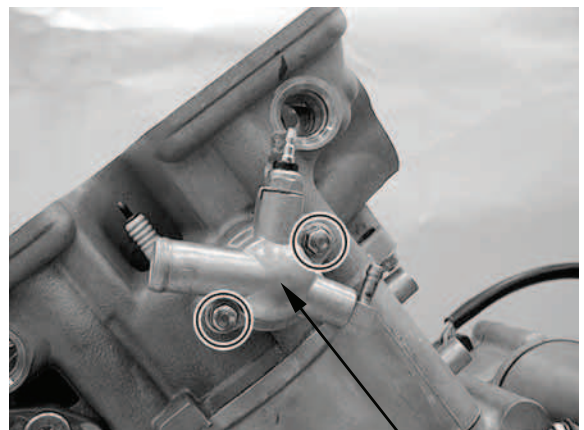

Water Joint/Gasket/Water Stop Collar

8. CYLINDER HEAD/VALVES

Remove the two nuts under the cylinder head.

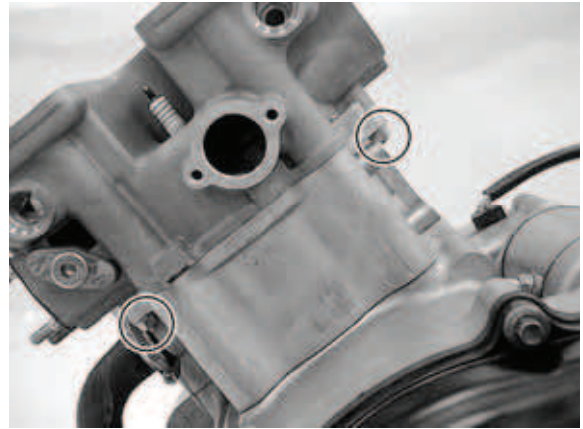

Remove the bolt and then remove the cylinder head.

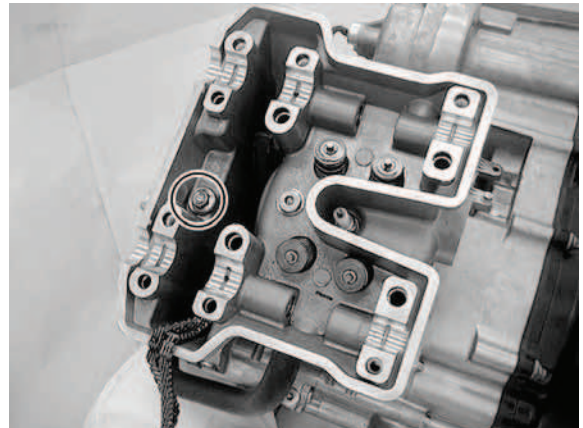

Remove the dowel pins and gasket.

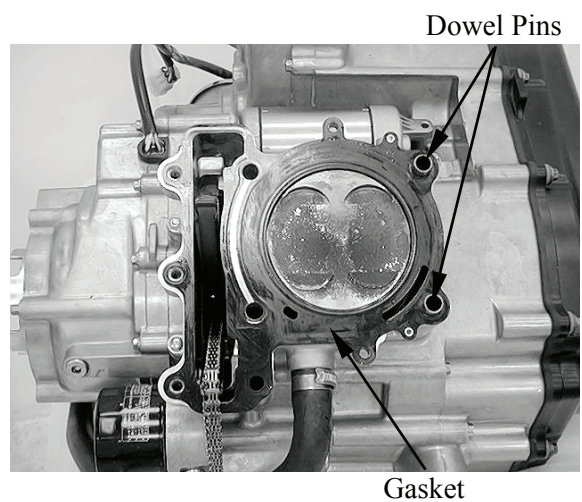

8. CYLINDER HEAD/VALVES

INSTALLATION

Install the dowel pins and new gasket as shown.

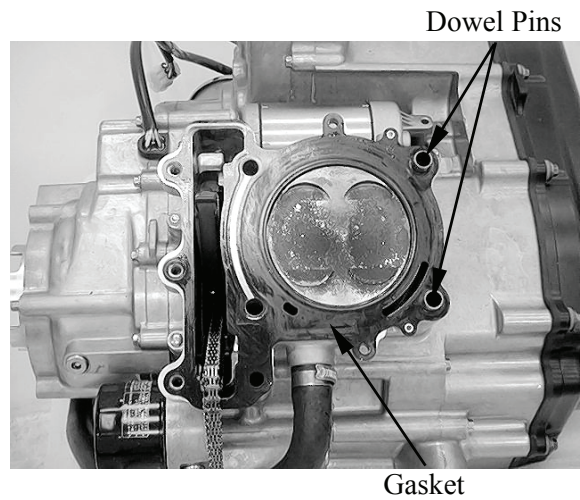

Install the cylinder head.

Apply engine oil to the cylinder head bolt (9) threads.

Install the bolt (9) but do not tighten it.

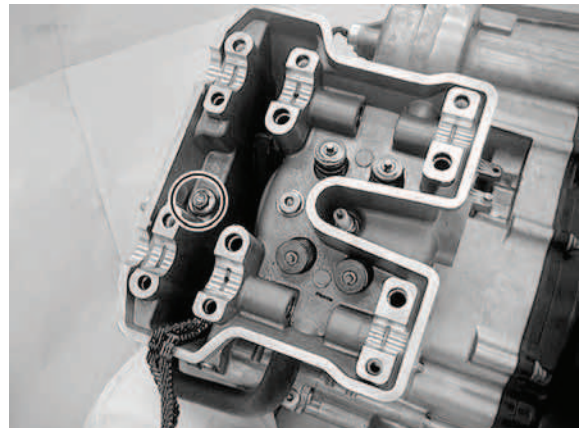

Install the camshafts, intake camshaft holder and exhaust camshaft holder (refer to the “CAMSHAFT REMOVAL/INSPECTION/INSTALLATION” section in this chapter).

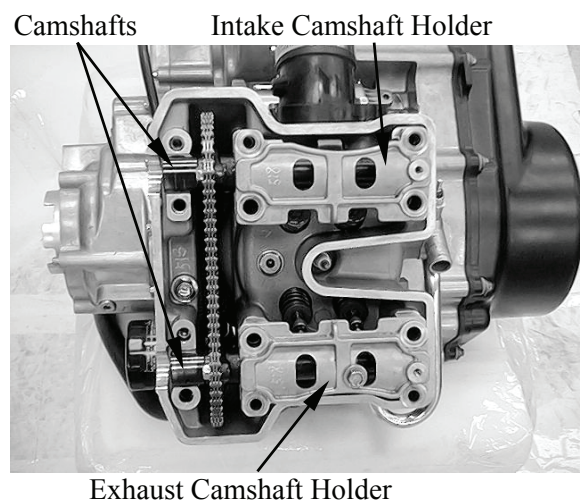

8. CYLINDER HEAD/VALVES

Apply engine oil to cylinder head bolt (No. 1 – 8) threads.

Install the four bolts (No. 5 – 8).

Install the four bolts/washers (No. 1 – 4).

Tighten the holder bolts (No. 1 – 9) in a crisscross pattern in five steps to the specified torque as follow diagram.

Tighten the bolts to the specified torque in sequence									
kgf-m (N-m)									
	(1)	(2)	(3)	(4)	(5)	(6)	(7)	(8)	(9)
Step 1	2.4 (24)	←	←	←	1.2 (12)	←	←	←	←
Step 2	3.8 (38)	←	←	←	2.3 (23)	←	←	←	←
Step 3	4.8 (48)	←	←	←					

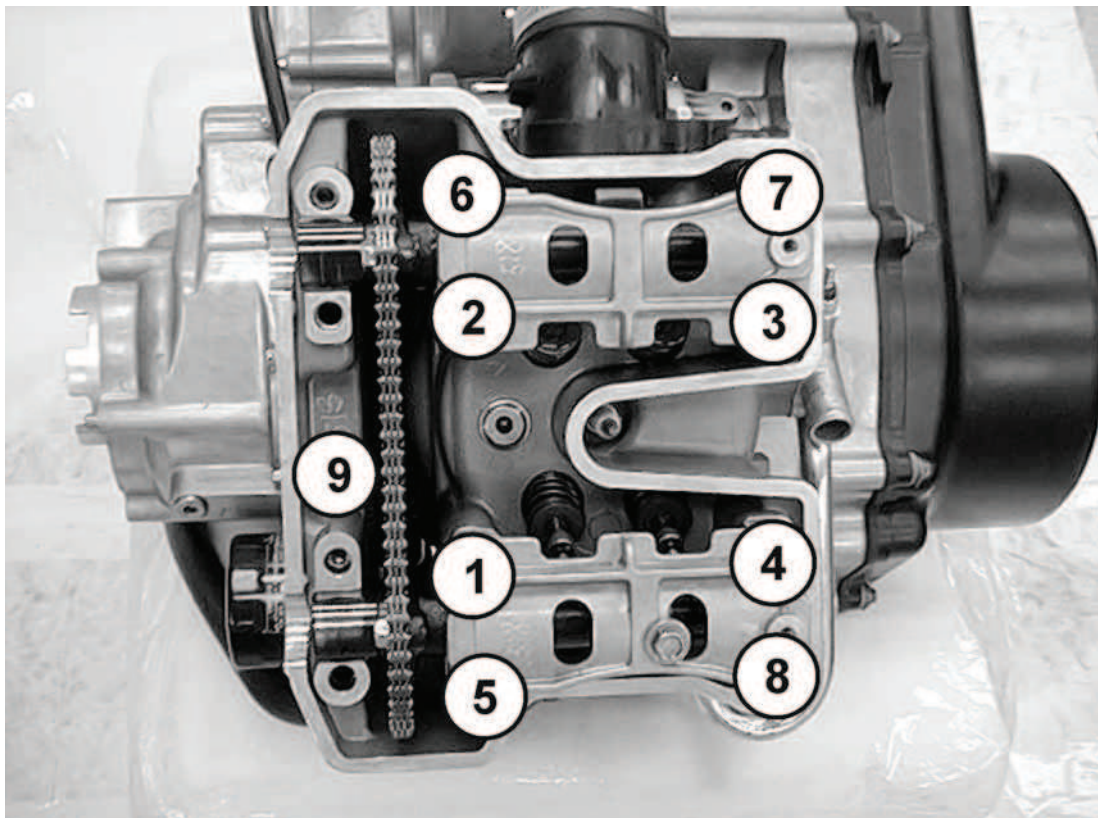

8. CYLINDER HEAD/VALVES

Apply engine oil to cylinder head bolt (No. 10 – 13) threads.

Install the common camshaft holder by arrow mark facing outside.

Install and tighten the holder bolts (No. 10 – 13) in a crisscross pattern in five steps to the specified torque as follow diagram.

Tighten the bolts to the specified torque in sequence									
kgf-m (N-m, lbf-ft)									
	(10)	(11)	(12)	(13)					
Step 4	1.2 (12, 9)	←	←	←					
Step 5	2.3 (23, 17)	←	←	←					

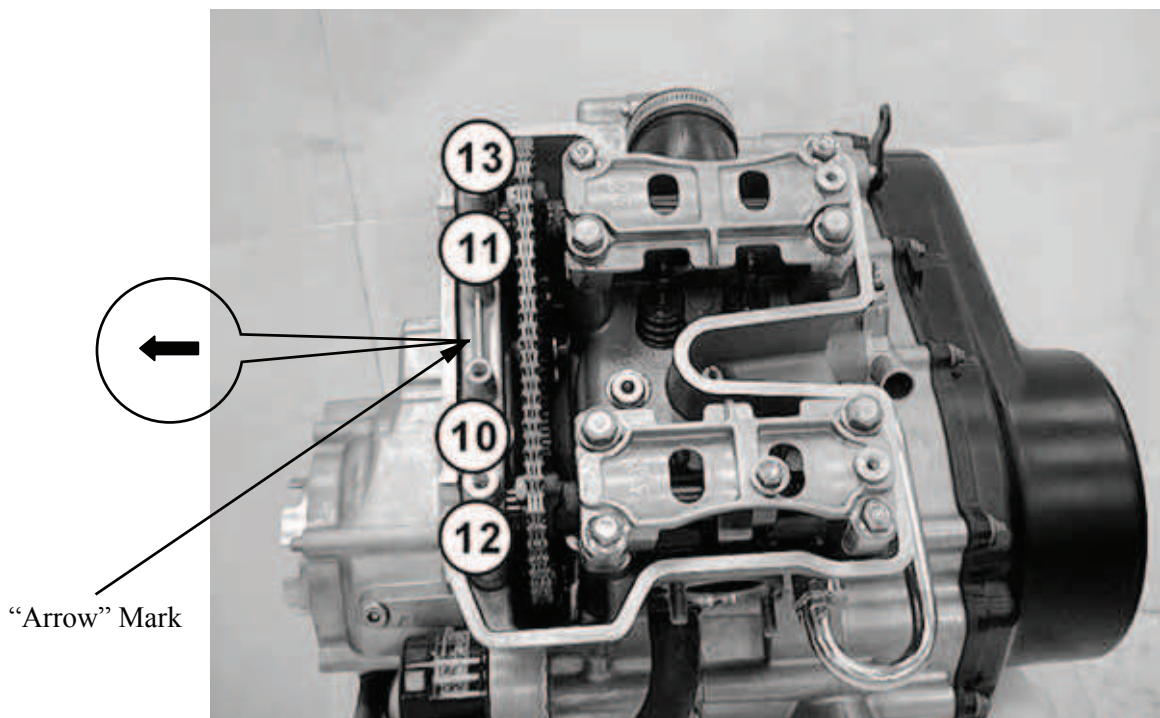

8. CYLINDER HEAD/VALVES

Install and tighten the two nuts under the cylinder head to the specified torque.

Torque: 1 kgf-m (10 N-m)



Install the water stop collar, gasket and water joint.

Install and tighten the two bolts to the specified torque.

Torque: 1.2 kgf-m (12 N-m)

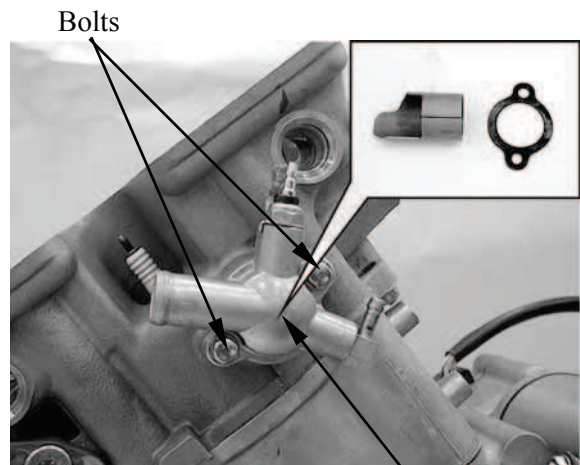

Water Joint/Gasket/Water Stop Collar

Install gasket and pair reed valve.
Install and tighten the five bolts and two nut securely.

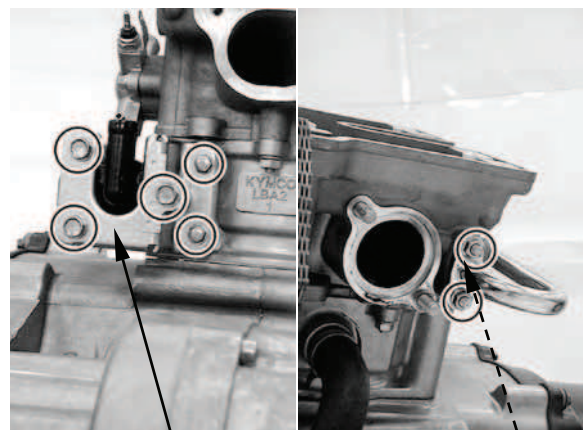

Pair Reed Valve Cover/Holder

Gasket

8. CYLINDER HEAD/VALVES

Install the new O-ring onto the intake pipe.



Install the intake pipe and tighten the two bolts securely.

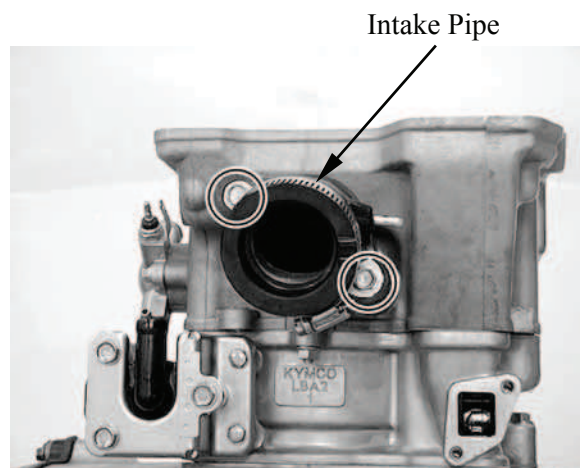

8. CYLINDER HEAD/VALVES

CYLINDER HEAD DISASSEMBLY/INSPECTION/ ASSEMBLY

Remove the cylinder head (refer to the “**CYLINDER HEAD REMOVAL/INSTALLATION**” section in this chapter).

Remove the valve spring cotters, retainers, springs, spring seats, oil seals and valves using a valve spring compressor.

*

- Be sure to compress the valve springs with a valve spring compressor.
- Mark all disassembled parts to ensure correct reassembly.

Valve Spring Compressor

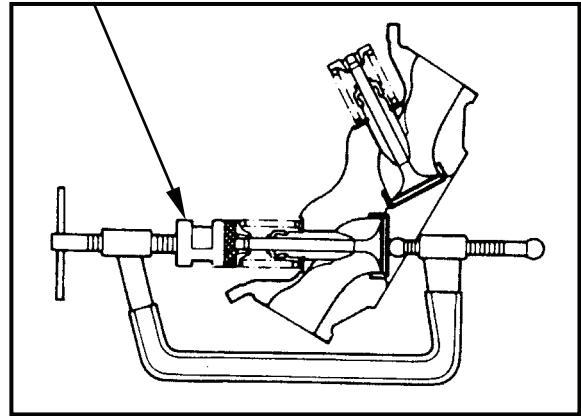

Special tool:

Valve Spring Compressor A120E00040

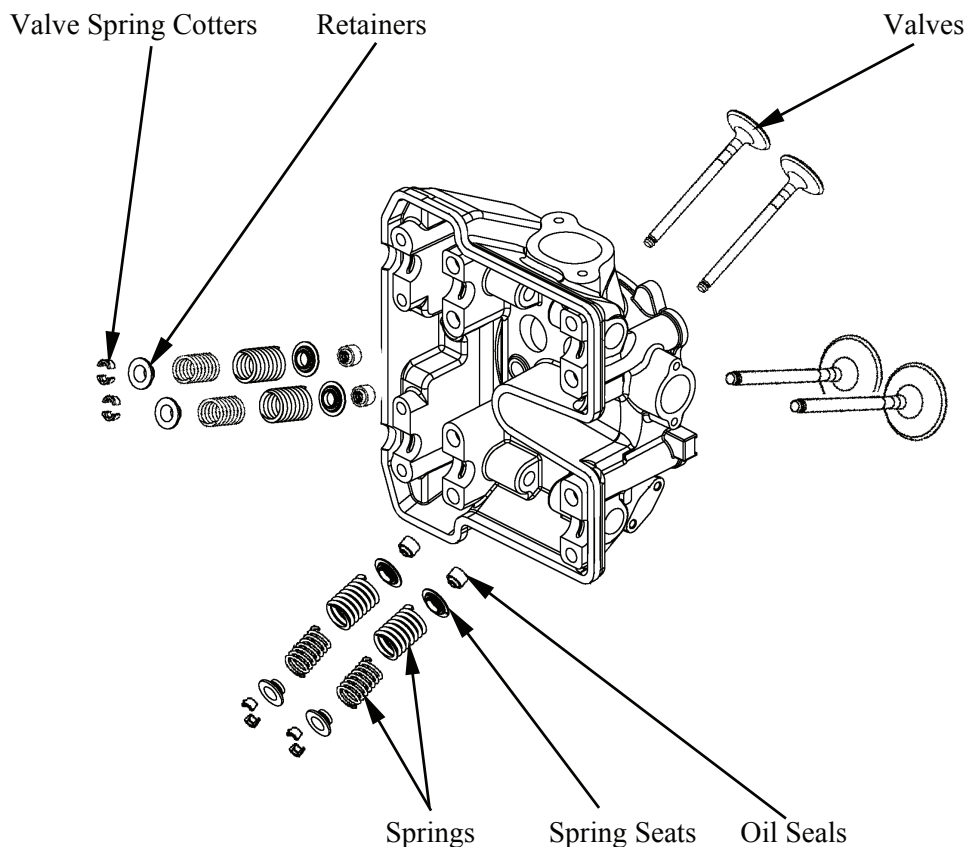

8. CYLINDER HEAD/VALVES

INSPECTION

Valve /Valve guide

Inspect each valve for bending, burning, scratches or abnormal stem wear.
If any defects are found, replace the valve with a new one.

Check valve movement in the guide.

Measure each valve stem O.D.

Measure each valve guide I.D.

Subtract each valve stem O.D. from the corresponding guide I.D. to obtain the stem-to-guide clearance.

Service limits:

IN: 0.08 mm

EX: 0.1 mm

* If the stem-to-guide clearance exceeds the service limits, replace the cylinder head is necessary.

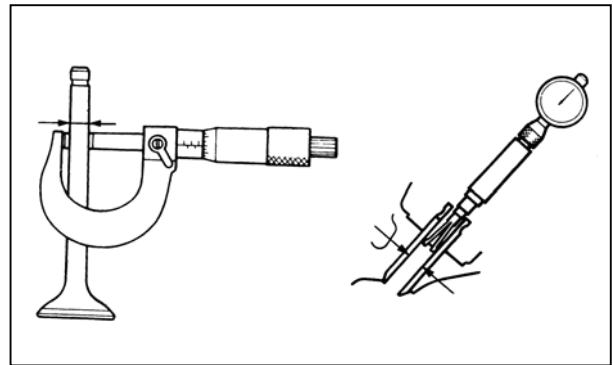

Cylinder head

Check the spark plug hole and valve areas for cracks.

Check the cylinder head for warpage with a straight edge and feeler gauge.

Service Limit: 0.05 mm (0.002 in)

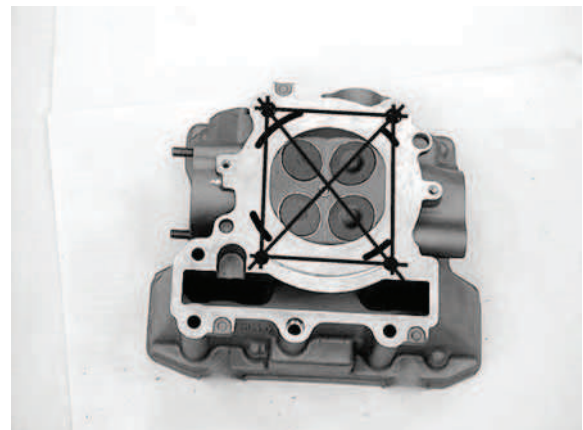

Valve spring

Measure the free length of the inner and outer valve springs.

Service Limit:

Inner: 33.4 mm

Outer: 38 mm

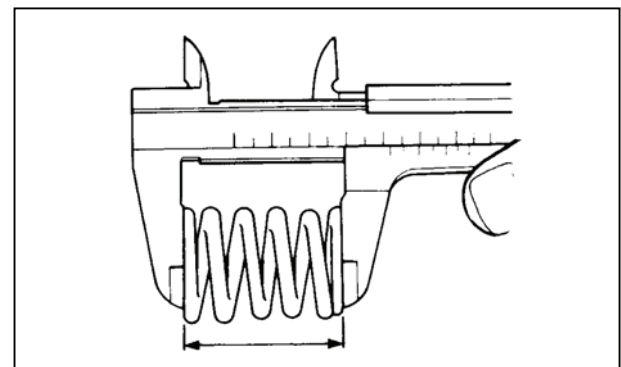

8. CYLINDER HEAD/VALVES

Measure compressed force (valve spring) and installed length.

Replace if out of specification.

Standard:

Inner: 3.5 kg (at 28.7 mm)

Outer: 13 kg (at 31.43 mm)

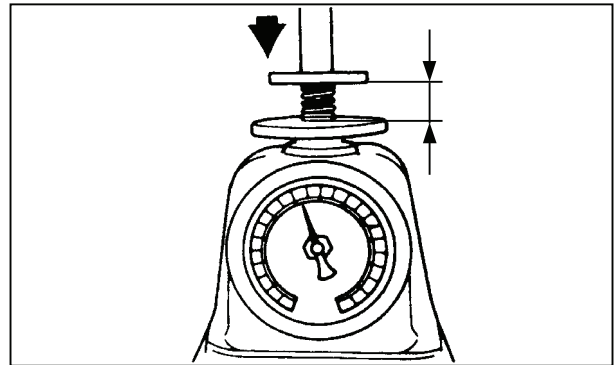

Measure the spring tilt.

Replace if out of specification.

Standard:

Inner: 1.2 mm

Outer: 1.2 mm

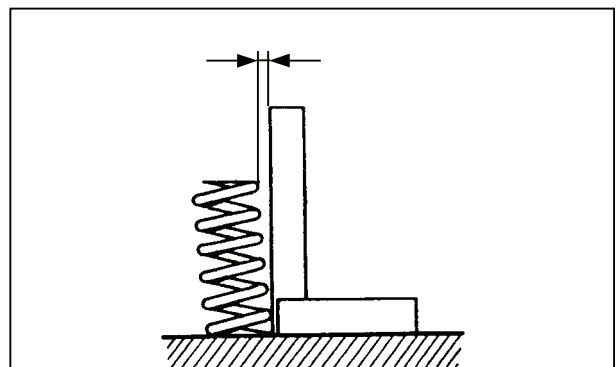

ASSEMBLY

Install the valve spring seats and oil seal.

* Be sure to install new oil seal.

Lubricate each valve with engine oil and insert the valves into the valve guides.
Install the valve springs and retainers.
Compress the valve springs using the valve spring compressor, then install the valve cotters.

* • When assembling, a valve spring compressor must be used.
• Install the cotters with the pointed ends facing down from the upper side of the cylinder head.

Valve Spring Compressor

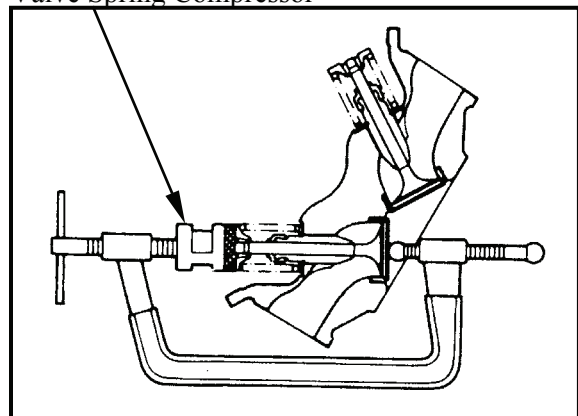

Special tool:

Valve Spring Compressor A120E00040

8. CYLINDER HEAD/VALVES

Tap the valve stems gently with a plastic hammer for 2~3 times to firmly seat the cotters.

* Be careful not to damage the valves.

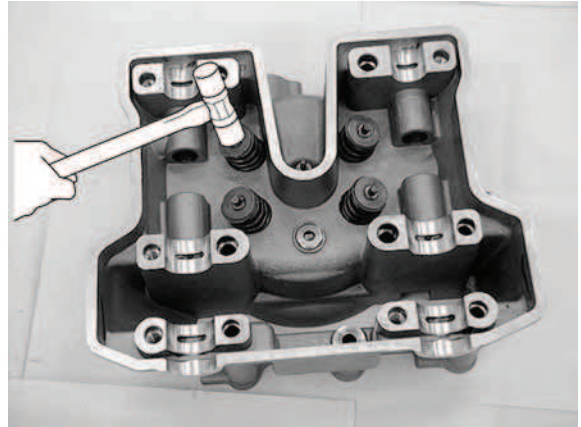

8. CYLINDER HEAD/VALVES

CAM CHAIN REMOVAL/INSPECTION/ INSTALLATION

REMOVAL

Remove the cylinder (refer to the “CYLINDER AND PISTON REMOVAL/INSPECTION/INSTALLATION” section in the chapter 9). Remove the oil pump drive chain (refer to “OIL PUMP REMOVAL/INSTALLATION” section in the chapter 4).

Remove the cam chain from the right crankcase.

Remove the two bolts and cam chain guides.

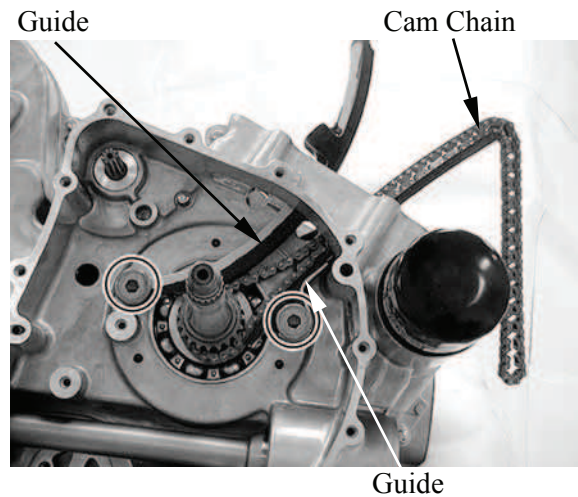

INSPECTION

Cam chain guide

Inspect the cam chain slipper surface of the cam chain guide for wear or damage.

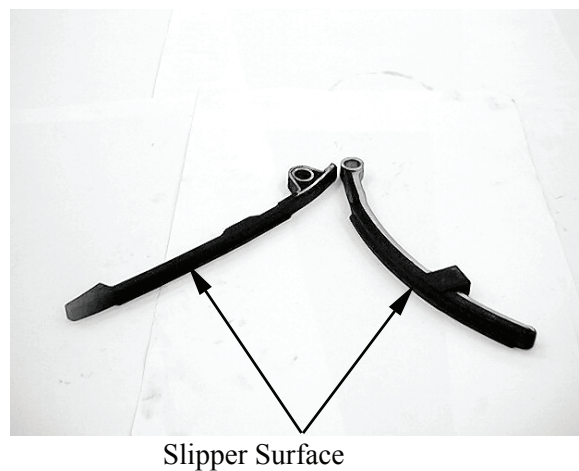

Cam chain

Inspect the cam chain for cracks or stiff.

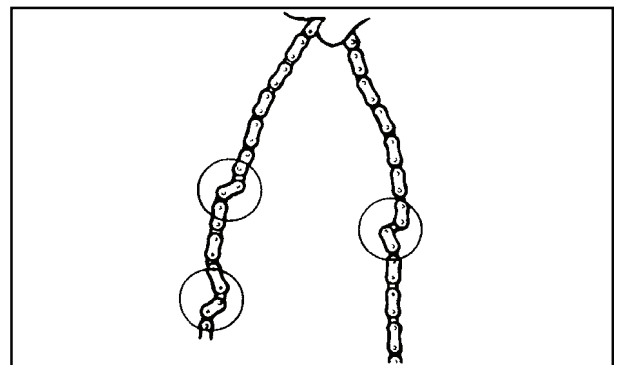

8. CYLINDER HEAD/VALVES

INSTALLATION

Installation is in the reverse order of removal.

Install the cam chain guides to the right crankcase and tighten the bolts to the specified torque.

Torque: 2 kgf-m (20 N-m)

